

# Adaptable Haptic Shared Control based on Grip Force

Smoothly shifting control authority

J. Hilte

Master of Science Thesis





# **Adaptable Haptic Shared Control based on Grip Force**

**Smoothly shifting control authority**

MASTER OF SCIENCE THESIS

For the degree of Master of Science in BioMechanical Design at Delft  
University of Technology

J. Hilte

December 10, 2017

Faculty of Mechanical, Maritime and Materials Engineering (Mechanical, Maritime and  
Materials Engineering (3mE)) · Delft University of Technology



Copyright © Mechanical Engineering (ME)  
All rights reserved.

DELFT UNIVERSITY OF TECHNOLOGY  
DEPARTMENT OF  
MECHANICAL ENGINEERING (ME)

The undersigned hereby certify that they have read and recommend to the Faculty of  
Mechanical, Maritime and Materials Engineering (3mE) for acceptance a thesis  
entitled

ADAPTABLE HAPTIC SHARED CONTROL BASED ON GRIP FORCE

by

J. HILTE

in partial fulfillment of the requirements for the degree of  
MASTER OF SCIENCE BIOMECHANICAL DESIGN

Dated: December 10, 2017

Supervisor(s):

\_\_\_\_\_  
dr.ir. D.A. Abbink

Reader(s):

\_\_\_\_\_  
dr.ir. B.M. Petermeijer

\_\_\_\_\_  
dr.ir. ?. ???



---

# Contents

<b>Paper</b>	<b>1</b>
<b>Adaptable Haptic Shared Control based on Grip Force</b>	<b>1</b>
Abstract . . . . .	1
I Introduction . . . . .	1
II Method . . . . .	2
III Results . . . . .	4
IV Discussion . . . . .	6
V Conclusion . . . . .	7
<hr/>	
<b>Appendices</b>	<b>8</b>
<b>A Apparatus</b>	<b>9</b>
A-1 Background . . . . .	9
A-2 Grip Force . . . . .	9
A-3 Criteria . . . . .	11
A-4 Sensors . . . . .	12
A-5 Current handle design . . . . .	15
<b>B Experiment Visualization</b>	<b>19</b>
B-1 Task Visualization . . . . .	19
B-2 Van-Der-Laen Questionnaire . . . . .	20
<b>C Experimental Protocol &amp; Informed Consent</b>	<b>21</b>
C-1 Experimental Protocol . . . . .	21
C-2 Informed Consent - Adaptable Haptic Shared Control . . . . .	23

<b>D Data</b>	<b>25</b>
D-1-18 Participant 1 - 18 . . . . .	26
D-19 Group . . . . .	44
<b>Bibliography</b>	<b>45</b>
<b>Glossary</b>	<b>47</b>
List of Acronyms . . . . .	47
List of Symbols . . . . .	47



---

# List of Figures

A-1	A few parameters that influence human grip force . . . . .	10
A-2	Proposed grip alignment to increase consistency with grip experiments. Adopted from Edgren et al., 2004 . . . . .	10
A-3	Four types of hand dynamometers. . . . .	11
A-4	Experimental Setup . . . . .	11
A-5	Tekscan FlexiForce A301 provided information. . . . .	12
A-6	Tekscan FlexiForce A301 provided information. . . . .	12
A-7	The ATI line (blue) is in Time vs Newton whereas the FlexiForce lines (red) are in Time vs Voltage. There are 2 pressure sensors inside each handle plate. . . . .	13
A-8	Measured Force with ATI vs measured Voltage with FlexiForce . . . . .	13
A-9	ATI measurement transformed from Newtons to Voltage. Each figure represents a different handle plate. . . . .	14
A-10	Tekscan FlexiForce A301 provided information. . . . .	15
A-11	Cantilever. . . . .	16
A-12	Beam Bending. . . . .	17
B-1	Visualization information. (only one of the three used obstacle order is represented)	19
B-2	Visualization of the digital van-der-Laen questionnaire . . . . .	20
C-1	Experimental setup and grip orientation on handle. . . . .	22
D-1	Data participant 1 . . . . .	26
D-2	Data participant 2 . . . . .	27
D-3	Data participant 3 . . . . .	28
D-4	Data participant 4 . . . . .	29
D-5	Data participant 5 . . . . .	30
D-6	Data participant 6 . . . . .	31

---

D-7 Data participant 7 . . . . .	32
D-8 Data participant 8 . . . . .	33
D-9 Data participant 9 . . . . .	34
D-10 Data participant 10 . . . . .	35
D-11 Data participant 11 . . . . .	36
D-12 Data participant 12 . . . . .	37
D-13 Data participant 13 . . . . .	38
D-14 Data participant 14 . . . . .	39
D-15 Data participant 15 . . . . .	40
D-16 Data participant 16 . . . . .	41
D-17 Data participant 17 . . . . .	42
D-18 Data participant 18 . . . . .	43
D-19 Group data . . . . .	44

---

# List of Tables

Table I: Experiment . . . . .	3
Table II: Results Obstacle Avoidance . . . . .	4



# Adaptable Haptic Shared Control based on Grip Force

J. Hilte, D.A. Abbink, R. J. Kuiper and S. M. Petermeijer - Delft University of Technology  
j.hilte@student.tudelft.nl, d.a.abbink@tudelft.nl, r.j.kuiper@tudelft.nl, s.m.petermeijer@tudelft.nl

**Abstract**—An important design choice for Haptic Shared Control is the magnitude of assisting forces: high assisting forces are beneficial during agreement between operator and controller, but also result in larger conflict forces in case of disagreement. In order to use higher forces without increasing conflict forces, literature proposes Adaptable Haptic Shared Control: using real-time operator grip force measurements to smoothly scale the magnitude of assisting forces. For full hand grip force no objective measurements comparing Haptic Shared Control versus Adaptable Haptic Shared Control are known and only very limited data on this comparison is available for finger pinching and subjective measurements. In order to prove that, using grip force to adapt the magnitude of assisting forces indeed leads to reduced conflict forces while maintaining the regular Haptic Shared Control performance during agreement, an experiment is required. It is hypothesized that Adaptable Haptic Shared Control will reduce conflict forces during disagreement and that the larger the disagreement the higher the grip force. Both an Adaptable and regular Haptic Shared Controller are designed and implemented on an actuated joystick, which is extended with a 2D dynamometer to allow real-time grip measurements. Eighteen subjects participated in an experiment where they used the Triar joystick to steer a virtual object along a path consisting of a multisine (agreement) interspersed with straight sections containing obstacles that needed to be avoided (conflict). After the adaptable and regular haptic shared control condition a Vanderlaan questionnaire was provided to the participant with the question to score them compared to manual control. During the path following task, both the Adaptable Haptic Shared controller and regular haptic shared controller provide similar increased performance in lateral deviation compared to manual control ( $p < 0.01$ ). During obstacle avoidance, the Adaptable Haptic shared control significantly decreased conflict forces compared to haptic shared control ( $p < 0.01$ ), but at a price of brief increased grip force. No significant difference in grip force was found between obstacles sizes (conflict). The subjective usefulness and satisfying score of adaptable and regular haptic shared control are both positive compared to manual but do not significantly differ from each other. Result show that with Adaptable Haptic Shared Control humans prefer increasing their grip force to lower the Haptic Shared Control forces during disagreement. Additionally during non-conflict situations they maintain the beneficial forces of Haptic Shared Control.

**Keywords**—adaptable haptic shared control; grip force; reduced conflict forces.

## I. INTRODUCTION

One of the proposed methods to improve human-automation interaction is using Haptic Shared Control (HSC) [1]. With HSC both human and automation both act on the same system by means of forces, resulting in shared control instead of traded control. Between manual control and full automation

an infinite number of levels of automation are possible. This level of automation for haptic devices is defined by [2] as the Level of Haptic Authority (LoHA) and indicates how much force the automation relates to deviation from its desired control inputs. Basic HSC systems can be described as a virtual spring linking the current position with the desired position. The magnitude of the HSC forces is then determined by the stiffness of this virtual spring. In most HSC systems this virtual spring stiffness is a static one-size-fits-all design choice, tuned through trial and error. Literature recognizes that a static LoHA is indeed insufficient for control tasks, especially complex tasks, where the discrepancy between performance as well as preferences results in an increase of conflict. [2], [3] However, making a dynamic spring stiffness, so the best LoHA for the situation can be used, requires a LoHA controller (someone that determines the LoHA). Adaptation of the LoHA can either be done by the automation itself (adaptive) or by the human (adaptable). Quality of the automation is only one of many factors that influences the optimal LoHA. Among quality of automation, cognitive and neuromuscular properties of the human operator as well as traditional human factors issues all influence the optimal LoHA. If the automation controls the LoHA, an algorithm based on a multitude of aforementioned parameters, including the individual control characteristics of the human, task performance, criticality and/or conflict forces, should be analyzed to determine the appropriate LoHA. Several of these parameter are inherently ambiguous, i.g. conflict forces. As [4] mentions, a certain level of conflict is a necessity during cooperation. But when are conflicting forces experienced as assisting and when as obstructing? So if the human is given the "responsibility" to adapt the LoHA to his/her preference, it keeps them "in control" by providing a direct way to influence the magnitude of the guidance forces.

### A. Grip force

The proposed method in literature for a human initiated adjustment of the LoHA during a control task is using grip force. [3] suggests to use this for switching between H-Modes whereas [2] suggests to use it to continuously shift between LoHA's. The reasons why grip force is an interesting parameter to use LoHA adaptation, is because during a control task grip force indicates the human willingness to comply. [5] showed, grip force is negatively related to arm admittance. A natural reaction to conflict forces and increased task difficulty is to

decrease arm admittance [6] and a corresponding increase in grip force.

For this paper the taxonomy presented by Cutkosky is used to differentiate between "power grip", using the whole hand, and "precision grip", pinching with the fingers. Grip force will refer to [7] power grip and pinch force to the precision grip category.

### B. Adaptable Haptic Shared Control

A paper on adaptable haptic guidance using pinching [8], explored the apparent contradiction in grip force and control strategies. On the one hand increased grip force would indicate increased task difficulty and thus a request for increased guidance forces. On the other hand increased grip force could indicate increased conflict forces and thus a request to reduce the guidance forces. For pinching, both the positive (higher grip force = higher LoHA) and negative (higher grip force = lower LoHA) relation resulted in reduced conflict forces. The difference between a positive and negative relation is that a negative relation by nature requires low grip force to benefit from correct guidance whereas a positive relation demands high grip force to benefit from correct guidance. For HSC systems where the guidance is mostly correct, a positive grip force - LoHA relation would increase the work load.

For using power grip to adapt the LoHA, [9] reports an increase in acceptance between using grip force to switch H-Modes versus touchscreen buttons.

So does measuring (power) grip force during a control task also provide the human with a way of LoHA adaptation that objectively increases performance during disagreement? Does introducing this extra degree of freedom result in reduced performance during agreement? And does this LoHA adaptation scale with conflict size?

### C. Hypothesis

Combining the literature that conflict decreases arm admittance and consequently increases grip force plus LoHA adaptation based on pinch force results in conflict reduction, leads to the first hypothesis. Compared to regular Haptic Shared Control, Adaptable Haptic Shared Control based on grip force will increase performance during disagreement by reducing conflict forces.

In addition literature reported an increase in acceptance when H-Mode adaptation is based on grip instead of buttons. Therefore, compared to regular Haptic Shared Control, an increase in acceptance is expected due to reduced conflict forces.

Finally larger disagreements lead to higher grip forces to maintain low conflict forces.

## II. METHOD

### A. Participants

From among the students and employees of Delft University of Technology 18 (16 male, 2 female) participants volunteer to complete the experiment. All participants were right handed and were  $28 \pm 10$  years of age. All participants had normal or corrected to normal vision and did not receive compensation for their time.

### B. Apparatus

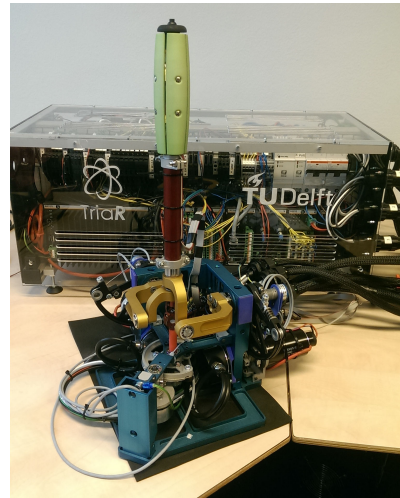

Fig. 1: TriaR, a 3 DOF actuated input device. Three Maxon electric motors are connected through a capstan transmission to their respective rotational axes of the handle. For more information see: <http://www.delfthapticslab.nl/device/triar>

To test the hypotheses an Adaptable and regular Haptic Shared Controller are designed as well as a real-time grip measuring handle. The handle incorporated a 2D dynamometer built by using 8 foil, Tekscan FlexiForce A301, pressure sensors on the inside of the handle, 2 on each handle plate. The handle was located on top of an actuated joystick (TriaR). The joystick is actuated on all 3 rotational degrees of freedom. However, for this experiment only 1 DOF is used. See figure 1. The joystick is actuated by a Maxon RE40 graphite brush DC motor and connected to the joystick by a capstan transmission. Strain gauges on the transmission between motor and joystick measured torques applied on the joystick. Potentiometers on the drive shaft and incremental encoders on the motors recorded joystick angles and velocity. All sensor inputs are sampled at 1kHz with a 16 bit A/D converter on a Bachmann real time system. Signals are filtered with a low pass filter with a cut-off frequency of ??? [look up!]

### C. Experiment design

The experiment used a within-subject repeated measures design consisting of 2 independent variables (type of support and obstacle size). In total each participant experienced 9 conditions. (see table II) To measure control task performance, a run consisting of 19 consecutive sections alternating between 10 multisine path following task and 9 straight obstacle avoidance task is designed. The ten multisine sections are made up out of a narrow ( $\sim 1/4$  screenwidth) multisine (see figure 2a). The nine obstacle avoidance sections are a straight wide ( $\sim 1/2$  screenwidth) path including one obstacle. Obstacles are represented by a thick white rounded bar blocking a portion of the path. (see figure 2b) Each obstacle size was presented 3 times over the entire length of

TABLE I: Experiment

Mode	Familiarization			Experimental Conditions											
	<i>MAN</i>	<i>HSC</i>	<i>AHSC</i>	<i>M</i> <sub>1</sub>			( <i>Q</i> )	<i>M</i> <sub>2</sub>			( <i>Q</i> )	<i>M</i> <sub>3</sub>			( <i>Q</i> )
Obstacles	<i>P</i> <sub>0</sub>			<i>P</i> <sub>1</sub>	<i>P</i> <sub>2</sub>	<i>P</i> <sub>3</sub>	<i>P</i> <sub>1</sub>	<i>P</i> <sub>2</sub>	<i>P</i> <sub>3</sub>	<i>P</i> <sub>1</sub>	<i>P</i> <sub>2</sub>	<i>P</i> <sub>3</sub>	<i>P</i> <sub>1</sub>	<i>P</i> <sub>2</sub>	<i>P</i> <sub>3</sub>
<i>M</i> <sub>1-3</sub>	Each indicate a mode (Manual ( <i>MAN</i> ), Haptic Shared Control ( <i>HSC</i> ) or Adaptable Haptic Shared Control ( <i>AHSC</i> )), used during the three consecutive paths <i>P</i> <sub>1-3</sub> .														
<i>Q</i>	After the <i>HSC</i> and <i>AHSC</i> mode a "van-der-Laan" questionnaire was provide.														
<i>P</i> <sub>1-3</sub>	Represents an order of the 9 obstacles (3x3 sizes) presented during that path.														
<i>P</i> <sub>0</sub>	Is a standard small, medium, large sequence for familiarization.														
	Both <i>M</i> <sub>1-3</sub> & <i>P</i> <sub>1-3</sub> are shuffled between participants using a latin square														

the run. The forward (vertical) speed of the dot is represented on the screen by a downward movement of the path. The downward velocity is set to a constant speed and the vertical screen position of the dot is always at 10% screen height. This gave participants 2 seconds of look ahead information on the screen.

1) *Independent variables*: The type of support during the experiment had three levels: no HSC (i.e. manual control), regular HSC and Adaptable HSC. Before a run started, participants were explicitly told which type of support was active. The obstacle size also consisted of three levels: Small, blocking the left side of the path and  $\frac{1}{4}$  of the right side. Medium, blocking the left side of the path and  $\frac{1}{2}$  of the right side. Large, blocking the left side of the path and  $\frac{3}{4}$  of the right side. To minimize order bias the order of the three support types were shuffled between participants using a latin square and the obstacle size order is shuffled within and between repetitions.

2) *Dependent variables*: The first three dependent variables identify the behavior during the obstacle avoidance task and are the exerted grip force on the handle, the torque force on the joystick and the joystick angle. The dependent variable indicating performance during the path following task is the mean lateral error from the center of the path by using equation 1 (the Root Mean Square Error). The  $n$  is the number of measurements during a multisine path following part, the  $\hat{x}_t$  represents the desired horizontal position at time  $t$  (center of the path at  $t$ ) and the  $x_t$  is the actual position at time  $t$ .

$$RMSE = \sqrt{\frac{\sum_{t=1}^n (\hat{x}_t - x_t)^2}{n}} \quad (1)$$

Lastly to measure acceptance a Van der Laan questionnaire was conducted after both HSC and AHSC, asking participants to compare them to manual control.

#### D. Task instruction

Participants were instructed to use the Triar to control the horizontal position of a red dot on a monitor. It must stay as safe (maintain the largest distance between red dot and white boundary / obstacle line) as possible. Also picture of

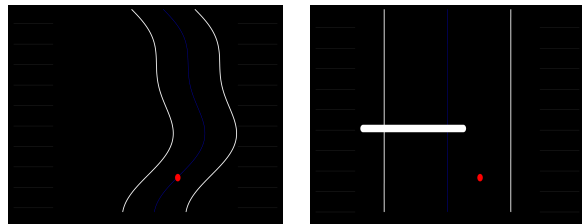

(a) Part of the multisine (b) Obstacle avoidance

Fig. 2: (a) shows part of the multisine path. (b) shows an obstacle during the obstacle avoidance part of the track. HSC forces are in both cases directed towards the center of the path.

the correct hand orientation on the joystick during the experiment was provided and explained to ensure hand orientation consistency. Participants are asked to, after they used the HSC and AHSC mode, score the system using the Van der Laan questionnaire comparing the support system to manual control. It was then verbally emphasized that they would start with a familiarization session to let them fully experience all 3 modes. Any remaining questions were answered during or at the end of that session.

#### E. Procedure

Participants were asked to read the experiment information leaflet explaining their task and the goal of the experiment. Each participant signed an informed consent form after which they proceeded to take a seat behind the experimental setup. The desk chair was placed behind the Triar joystick and a 19 inch monitor. Once on the designated chair, participants were asked to grab the joystick so the height of the chair and the orientation of the hand could be checked. Once correctly positioned participants started with the familiarization phase, consisting of manual, HSC and AHSC. For all three modes participants experienced the task and how it would feel. Any remaining questions were answered during this phase. After the familiarization phase participants would execute the randomized condition order. Each condition took about 10 min to complete and after the HSC and AHSC condition, a digital VDL questionnaire was provided.

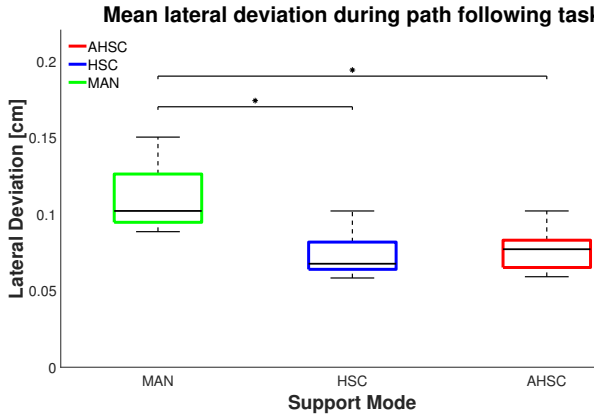

Fig. 3: The mean lateral deviation during path following is calculated with the RMSE (see equation 1). The boxplot shows the median with a black line within the box, 25th and 75th percentile indicated by the bottom and top of the colored box respectively and the minimum and maximum values by the whiskers above and below the box. Brackets indicate significance by means of asterisks, one asterisk (\*) indicates  $p < 0.01$ .

#### F. Data analysis

The path following part is evaluated by removing the first and last section of the trial and then calculating the root mean square error of the lateral deviation from the center over the remaining 8 sections. This indicates how accurate this task was executed. For the obstacle avoidance task, the grip force and joystick torque at the moment of passing the obstacle are used. For both the path following and the obstacle avoiding task a one-way repeated measure ANOVA is used to analyze the acquired data. The VDL is first checked for reliability with Cronbach's  $\alpha$  and then evaluated by a one-way repeated measures ANOVA. Significance is assumed for  $p < 0.05$ . One asterisk (\*) indicates  $p < 0.01$  and two asterisks (\*\*) indicate  $p < 0.05$ .

### III. RESULTS

#### A. Path following

In figure 3 the root mean square error of the lateral deviation is shown for all three conditions. During manual control

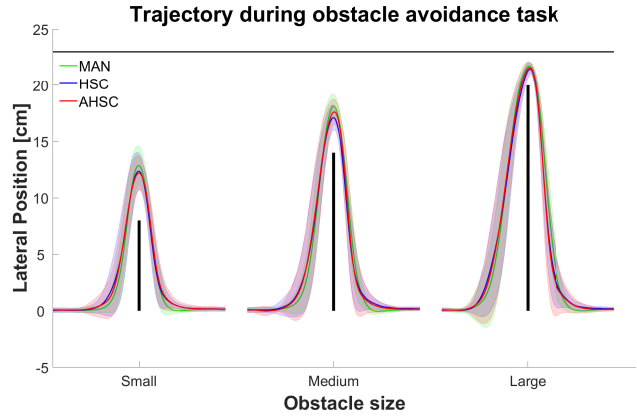

Fig. 4: The mean trajectory including the standard deviation (transparent band around solid line) are plotted for each support mode and obstacle size. For each obstacle size, the trajectory of each support modes strongly overlap one another.

participants deviated from the center of the multisine by  $M = 0.110$ ,  $SE = 0.005$  [cm]. This is significantly larger ( $p < 0.01$ ) than the  $M = 0.076$ ,  $SE = 0.004$  [cm] and  $M = 0.079$ ,  $SE = 0.004$  [cm] for respectively HSC and AHSC.

#### B. Obstacle avoidance

Figure 4 shows the trajectory during obstacle avoidance. For all three conditions and all three obstacle sizes, the trajectory used to avoid the obstacle seem highly similar. However, the in figure 5 displayed grip and torque forces on the handle show that although the trajectory look similar, there actually is a significant difference between conditions. Mean (M) and Standard Error (SE) values are provided in table II. Figure 5 also indicates that there is a significant difference ( $p < 0.01$ ) for each obstacle size during HSC and their respective AHSC part for both grip force as well as torque.

TABLE II: Results Obstacle Avoidance

	Grip Force [N]			Torque [Nm]		
	Small	Medium	Large	Small	Medium	Large
MAN	M = 10.09 SE = 0.05	M = 10.14 SE = 0.08	M = 10.29 SE = 0.16	M = 0.060 SE = 0.022	M = 0.081 SE = 0.023	M = 0.128 SE = 0.024
HSC	M = 11.25 SE = 0.60	M = 11.85 SE = 0.91	M = 12.19 SE = 1.11	M = 1.886 SE = 0.048	M = 2.550 SE = 0.020	M = 3.057 SE = 0.057
AHSC	M = 29.68 SE = 3.56	M = 35.60 SE = 4.02	M = 37.58 SE = 4.09	M = 0.838 SE = 0.120	M = 0.909 SE = 0.156	M = 1.068 SE = 0.193

This table provides the mean (M) and standard error (SE) values over all participants corresponding to conditions in figure 5.



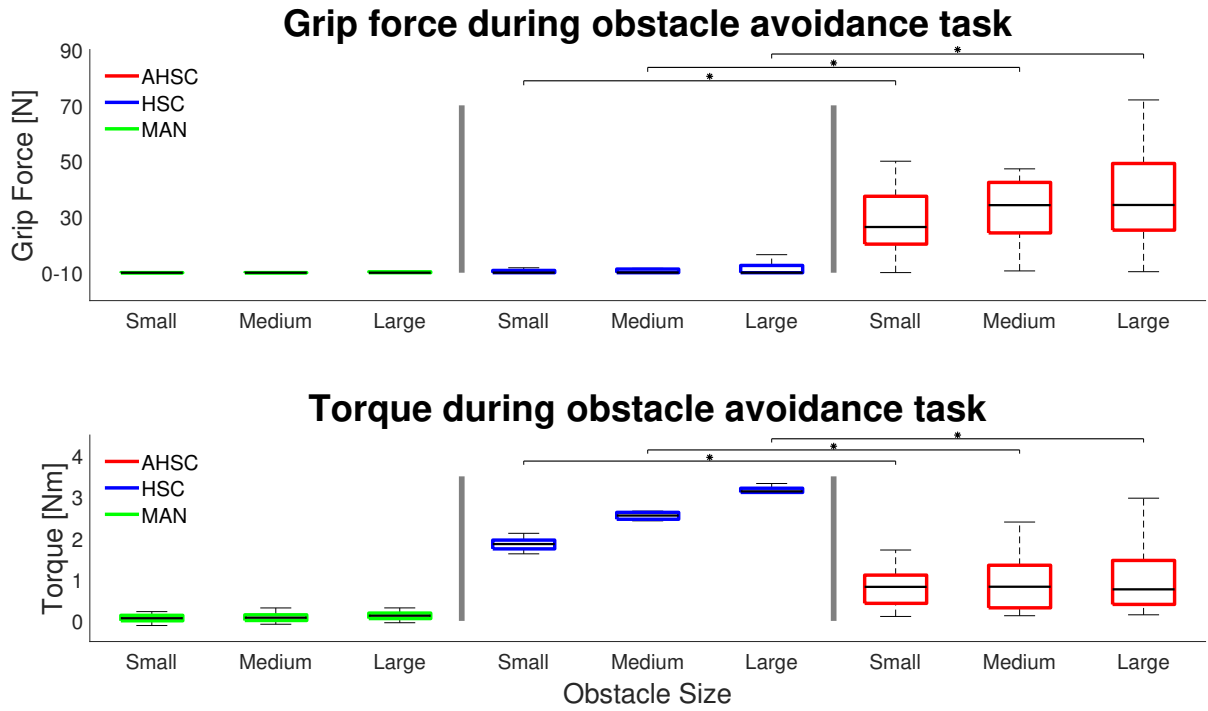

Fig. 5: Top: Boxplot of the mean grip force during the three modes and three obstacle sizes. The median is indicated with a black line within the box, the 25th and 75th percentile are respectively the bottom and top of the colored box and the minimum and maximum values are marked by the whiskers below and above the box. Bottom: Boxplot of the mean torque during the three modes and three obstacle sizes. The median is indicated with a black line within the box, the 25th and 75th percentile are respectively the bottom and top of the colored box and the minimum and maximum values are marked by the whiskers below and above the box. Significance is indicated by one asterisk (\*) for  $p < 0.01$  and two asterisks (\*\*) for  $p < 0.05$ .

### C. VanderLaan

The van der Laan questionnaire that was used after the HSC and AHSC trials indicates that the participants rated both HSC and AHSC as useful and satisfying compared to manual control. (see figure 6) HSC had a mean (satisfying, usefulness) score of  $[0.9583, 0.9556] \pm [0.6139, 0.4204]$  and for AHSC the mean scores were  $[1.1944, 1.1111] \pm [0.5185, 0.3306]$ . The repeated measure ANOVA and as an extra check the Wilcoxon Signed Rank test both turned out to indicate no significant difference for usefulness and satisfying between HSC and AHSC.

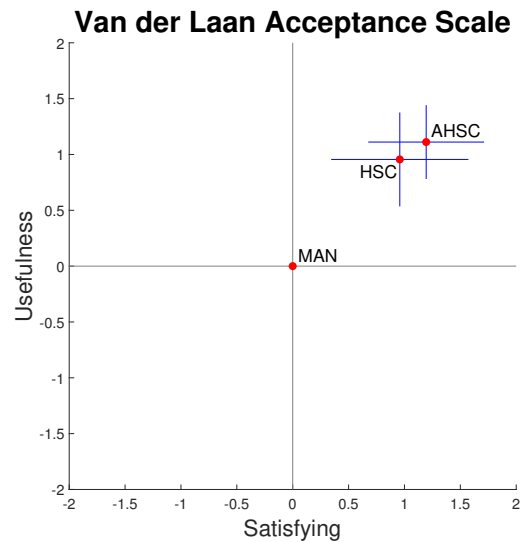

Fig. 6: System acceptance scale as defined by van der Laan indicating the usefulness and satisfying.

## IV. DISCUSSION

### A. Human control strategy during conflict

During manual control, both grip force and torque are low (see figure 5). The only observed torque during manual control where due to accelerations of the handle to the right and back to the left, depicting a characteristic 'S' curve. During the HSC mode the grip force remained similar to the manual mode but the torque on the joystick increased significantly due to conflict between human and HSC system. This conflict is due to the HSC system trying to follow center of the path while the human was avoiding the obstacle. Although for this task this did not result in a worse trajectory, the workload did increase as the participant had to overpower the conflicting forces of the HSC system. Providing the possibility to adapt the LoHA by grip force led to a significant decrease of those torque forces during conflict but at a cost of increased grip force. In [8] equivalent results were found when using pinching instead of power grip to adapt the LoHA. Although the TriAR was limited in the maximum possible LoHA it could enforce, making it relatively easy for participants to overpower the system even if grip force are zero during large conflict, the majority of the participants chose to lower the LoHA by increasing their grip force. One of the explanations for this strategy is that the metabolic cost of increasing grip force is less than the metabolic cost for overpowering the HSC system by reducing arm admittance. The conflict torque force did not only drop, but the transition between LoHA's during obstacle avoidance did not seem to negatively impact the trajectory around the obstacle. (see figure 4)

Besides the "grip force - torque" trade-off, figure 5 also shows that the between-subject variability of both grip force and torque increases substantially. The torque variability is a direct result of the grip force variability. When analyzing the grip force data for each participant separately, the individual grip force variability decreases compared to the group grip force variability. This indicates that for this experiment, humans behaviour differed more between participants than between repetitions. Also for each obstacle size the within-subject variability of the mean grip force is highly similar, just like the group mean grip force for each obstacle size as illustrated in figure 5. This leads to believe that for this experiment participants used the possibility to adapt the LoHA by means of grip force as a high-low button. Such a strategy is best described with the H-Mode by [3] smoothly switching between two (extreme) LoHA modes. This would also explain why for this experiment the conflict size did not significantly influence the grip force. When looking at the raw data, another interesting phenomenon is the tendency for participants to quickly loosen the grip force right after they passed the obstacle. This leads to a rapid increase in LoHA and would therefore quickly force the joystick back to the center line resulting in an overshoot. To reduce overshoot resulting from rapid grip force reduction can be solved by implementing a one sided rate limiter to limit the speed at which the LoHA can increase.

### B. Limitation in grip force measurement

Grip forces in this experiment lacks measurements between 0 and 10 N. This is due to design and implementation limitations of the handle in combination with the used FlexiForce pressure sensors. Although this might have lead to a more binary gripping behaviour, there is still a clear difference between AHSC grip force and MAN or HSC grip force. This limitation also reduced the ability to clearly investigate grip force behavior during low grip force control, particularly interesting for MAN and HSC control. In addition the possibility to accurately identify the start of an increase in grip force is near impossible.

### C. Task difficulty

Feedback from several participants indicated that the avoidance task was very easy and because the conflict forces weren't high enough to force participants to use the LoHA adaptation, some actually liked to use the HSC as a spring to fling the red dot around the obstacle. This might have been reduced by not avoiding 1 obstacle at a time but a more complex avoidance task to increase the task difficulty and therefore the need to reduce conflict forces. However, because the obstacle avoidance was easy and could be executed without adaptation of the LoHA, the result strongly suggest that participants weren't forced but chose to use the possible LoHA adaptation. Another remark was the fact that the obstacles always had to be avoided by moving to the right. Making it predictable how to act during avoidance. The reason for this one sided obstacle avoidance was to remove any decision making artifacts in the trajectory during the avoidance manoeuvre. Thereby making a trajectory comparison between modes more clear.

### D. Future work

Future experiments involving LoHA adaptation by means of grip force might focus on discriminating continues adaptation from binary and/or multistage adaptation by means of acceptance. Visualizing the LoHA to increasing transparency by indicate current LoHA. This could provide insight in the threshold of acceptance of conflict with an adaptable system. Another interesting research area would be introducing the option of LoHA adaptation during a more complex tasks where their is an alternative way to reduce task difficulty, e.g. where the velocity is also controlled by the human. This might indicate if humans prefer adapting the LoHA by means of grip force or by reducing forward speed or any combination of the two.

## V. CONCLUSION

Due to limitations in automation the performance of HSC can conflict with that of the human, resulting in conflict forces that reduce performance. Using AHSC by means of grip force, provides the human with the possibility to continually adjust the level of Haptic Authority. For the provided control task:

- during non-conflict situations humans utilize the assisting forces to improve performance.
- during conflict situations humans preferred increasing their grip force to lower the LoHA.
- humans preferred assistance in the form of HSC or AHSC compared to MAN control.

Therefore AHSC provides reduction of conflict forces during disagreement at the cost of increased grip force and retains the beneficial forces during non-conflict situations increasing performance.

## REFERENCES

- [1] D. Abbink and M. Mulder, "Neuromuscular Analysis as a Guideline in designing Shared Control," *Advances in Haptics*, pp. 499–517, 2010.
- [2] D. A. Abbink, M. Mulder, and E. R. Boer, "Haptic shared control: Smoothly shifting control authority?" *Cognition, Technology and Work*, vol. 14, no. 1, pp. 19–28, 2012.
- [3] F. Flemisch, J. Kelsch, C. Löper, A. Schieben, and J. Schindler, "Automation spectrum , inner/outer compatibility and other potentially useful human factors concepts for assistance and automation," *Human Factors for Assistance and Automation*, no. 2008, pp. 1–16, 2008.
- [4] J.-M. Hoc, "From human - machine interaction to human - machine cooperation," *Ergonomics*, vol. 43, no. 7, pp. 833–843, 2000.
- [5] H. Nakamura, D. Abbink, and M. Mulder, "Is grip strength related to neuromuscular admittance during steering wheel control?" *2011 IEEE International Conference on Systems, Man, and Cybernetics*, pp. 1658–1663, 2011.
- [6] D. A. Abbink, "Task instruction: The largest influence on human operator motion control dynamics," *Proceedings - Second Joint EuroHaptics Conference and Symposium on Haptic Interfaces for Virtual Environment and Teleoperator Systems, World Haptics 2007*, pp. 206–211, 2007.
- [7] M. R. Cutkosky, "On Grasp Choice, Grasp Models, and the Design of Hands for Manufacturing Tasks," *IEEE Transactions on Robotics and Automation*, vol. 5, no. 3, pp. 269–279, 1989.
- [8] J. Smisek, W. Mugge, and J. B. J. Smeets, "Adapting Haptic Guidance Authority based on User Grip," *2014 IEEE International Conference on Systems, Man, and Cybernetics*, no. 1, pp. 1516–1521, 2014.
- [9] D. Damböck, M. Kienle, K. Bengler, and H. Bubb, "The H-metaphor as an example for cooperative vehicle driving," *Lecture Notes in Computer Science (including subseries Lecture Notes in Artificial Intelligence and Lecture Notes in Bioinformatics)*, vol. 6763 LNCS, no. PART 3, pp. 376–385, 2011.



---

# Appendix A

---

## Apparatus

### A-1 Background

For Haptic Shared Control experiments by the Delft Haptics Lab a three degrees of freedom actuated joystick was designed and built. This joystick had to be modified to be able to measure grip forces on the handle. Therefore a new handle including force sensors were designed and built. The design of this handle is based on a common grip dynamometer and a few grip parameter found in literature.

### A-2 Grip Force

Because gripping is such a vague description of a grasping action, it was important to define the type of grip used. Cutkosky [7] distinguishes 'grasp' in power and precision where power uses the whole hand (like a fist) and precision only uses the finger(tip)s. Although this taxonomy remains incomplete, it does provide a good way to clarify the type of grip used during the control task and also helps to increase consistency. Besides the type of grip, a few other parameters for grip force are investigated to create some criteria for the joystick handle.

#### Grip Parameters

Literature holds a vast amount of papers considering all kinds of grip, grasp and pinch research. Although a large portion is focused on change in grip force related to disease, there is also a lot of data regarding *maximal* grip force. Even though maximal grip isn't something encountered often during control tasks, it does describe some key relations for designing a grip interface and post grip analysis. For example, Mathiowetz et al. [14] demonstrated the relation between maximal grip force and age/sex. Although from a different paper, Figure A-1a illustrates the same conclusion. As can be expected, males have a higher average and maximal grip force compared to females and for both sexes this decreases with age. In order to be able

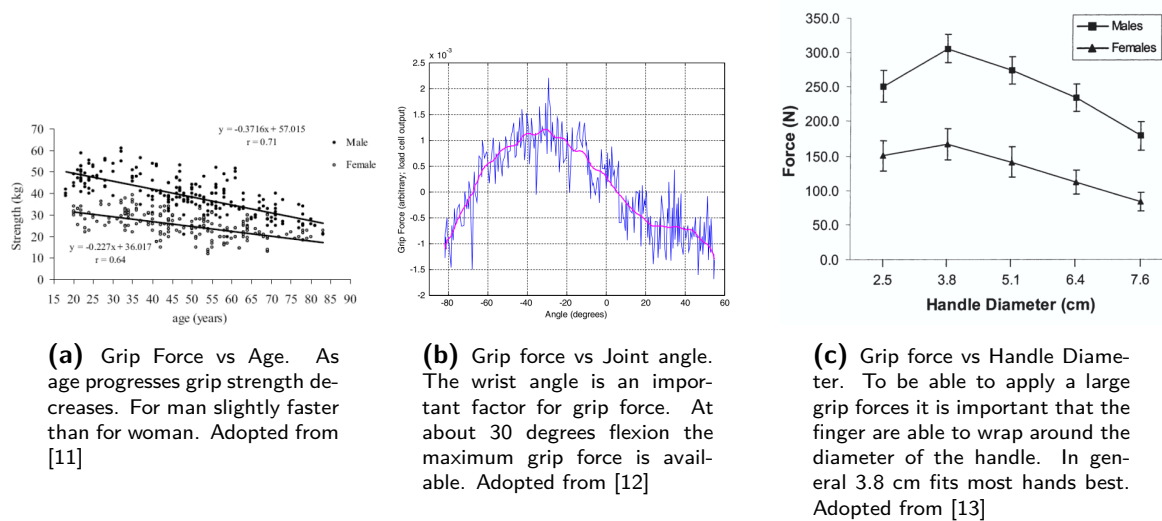
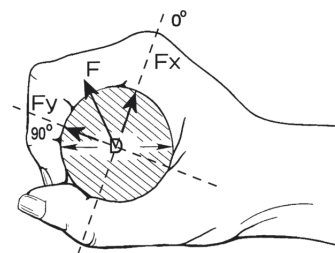

**Figure A-1:** A few parameters that influence human grip force

to use grip force as an input for AHSC systems, it seems logical to use normalized grip forces based on that user's maximal grip force. This would have been an interesting improvement for the experiment.

Besides sex and age, joint angles also influence grip force. Morse et al. [12] showed the relation between wrist angle and maximum grip force. In Figure A-1b it is clear that the maximal grip force is at a slightly flexed wrist. The shoulder and elbow orientation also influence the final grip force but are less significant. To limit wrist angles during the experiment, a standardized grip position is provided in the experimental information and checked by the experimenter before starting (see Figure A-2). Edgren et al. [13] demonstrated the influence of handle diameter on human maximal grip force. A handle diameter between 2.5 and 5.1 cm resulted in the highest applicable grip force. This paper also provided a grip alignment scheme for the x and y axis to increase consistency and reduce deviations in wrist angle.

**Figure A-2:** Proposed grip alignment to increase consistency with grip experiments. Adopted from Edgren et al., 2004



## Measuring Grip

In general there are 4 types of dynamometer. For the joystick handle a combination of Figure A-3b and Figure A-3d is used as this was the cheapest and most easy to miniaturize into a 2D dynamometer inside of a joystick handle.



(a) Hand dynamometer using a spring to measure grip force.



(b) Hand dynamometer using hydraulic pressure to measure grip force.



(c) Hand dynamometer using pneumatic pressure to measure grip force.



(d) Hand dynamometer using electric strain gauge to measure grip force.

**Figure A-3:** Four types of hand dynamometers.

## A-3 Criteria

The handle should meet the following requirements:

Topic	Requirements
Outer Diameter	25 - 50 mm
Grip force per plate	Up to 250 N
Force Accuracy	< 0.1 N
Fast Response	< 100 ms
Number of force directions	4
Orientation	Symmetric for both left and right handed
Maintenance	Components should be easily replaceable

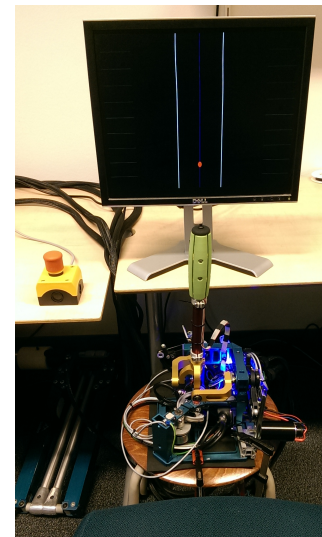

**Figure A-4:** Experimental Setup

### A-4 Sensors

To measure the applied grip force, eight Tekscan FlexiForce A301 pressure sensors were ordered. Two on the inside of each plate, one on top and one on the bottom. The manufacturer of the FlexiForce sensors provides the following installation suggestion and performance characteristic: The circuit that was used for the sensors deviates from the, by the manufacturer

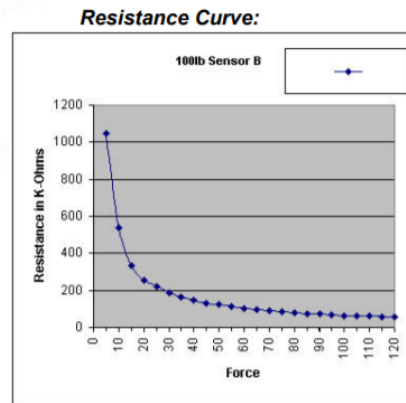
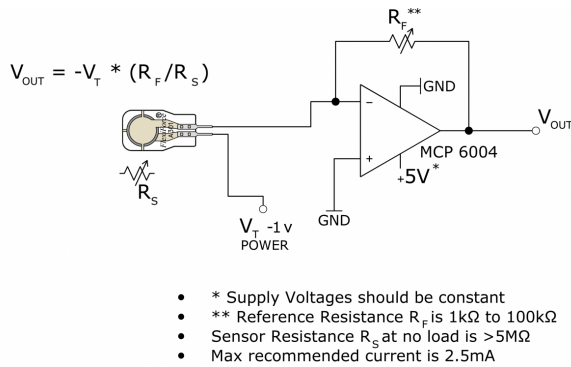

(a) Tekscan FlexiForce A301 connection suggestion. (b) Tekscan FlexiForce A301 Resistance Curve indicating electrical resistance of sensor for different static force loads. Source FlexiForce A301 Manual

Figure A-5: Tekscan FlexiForce A301 provided information.

recommended circuit, mainly due to the absence of the correct hardware. It was theorized that using a sensor in series with a fixed resistor would provide comparable results.

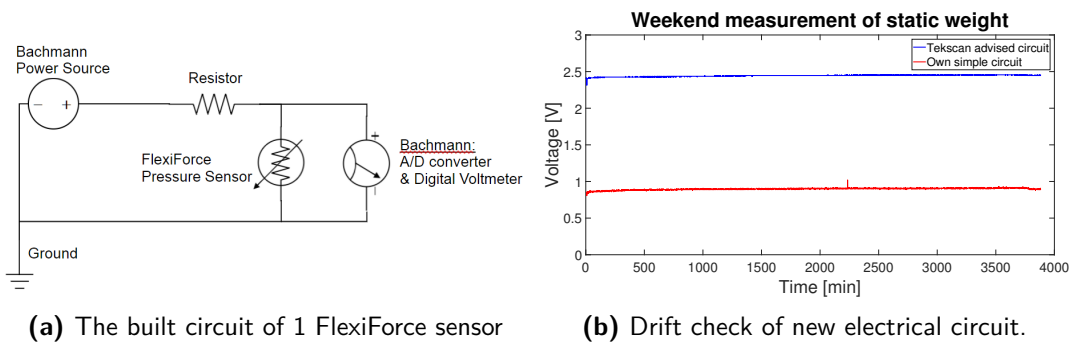

(a) The built circuit of 1 FlexiForce sensor (b) Drift check of new electrical circuit.

Figure A-6: Tekscan FlexiForce A301 provided information.

To test if the sensor in series wouldn't suffer from drift over time, two sensors were statically loaded for a whole weekend. One had the recommended circuit and the other the custom resistor in series. The result of this test indicate that both sensors don't show drift over time.



## Calibration

To calibrate the grip force sensing handle, an ATI 6-Degree(s) of Freedom (DOF) calibrated force sensor was used. The TriaR handle was placed in the vertical position with one side against the ATI 6-DOF force sensor. The ATI force sensor was held in place and fixated to the desk by means of aluminum extrusion profiles. An arbitrary force was applied manually to the opposing side of the handle pushing the handle towards the ATI sensor. The signal of both ATI and FlexiForce sensors are recorded by the Bachmann running at 1kHz.

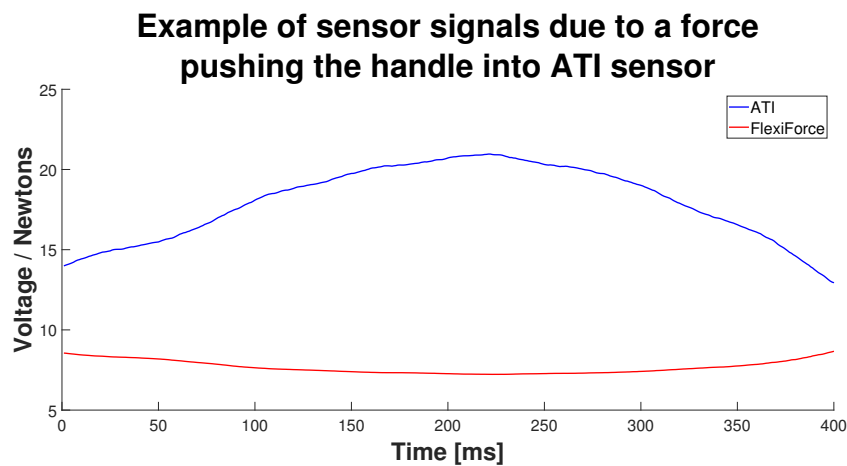

**Figure A-7:** The ATI line (blue) is in Time vs Newton whereas the FlexiForce lines (red) are in Time vs Voltage. There are 2 pressure sensors inside each handle plate.

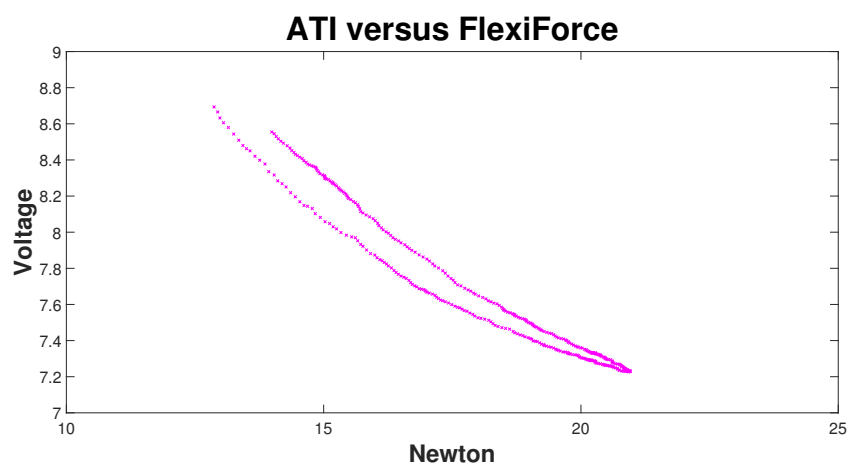

**Figure A-8:** Measured Force with ATI vs measured Voltage with FlexiForce

Figure A-7 shows the resistance of the FlexiForce foil pressure sensors decreases with increased pressure. In the Tekscan information leaflet it is clear that they indeed follow some logarithmic function, reducing resistance as force increases. In order to translate the measured grip

Voltage to Newtons, this mapping function is required. A logarithmic function of the form:

$$V_{out} = A - B \cdot \log\left(\frac{F_{meas}}{C}\right) \quad (\text{A-1})$$

is used to try to find the  $a$ ,  $b$  and  $c$  parameters that best fit the ATI data onto the FlexiForce data. For each plate these values were slightly different.

Using the found formula, the ATI signal has been transformed so it should fit the measured signal from the handle. Figure A-9 shows the difference between transformed ATI signal and measured FlexiForce signal.

$$V_{out} = 4.5653 - 3.0169 \cdot \log\left(\frac{F_{meas}}{49.9348}\right) \quad (\text{A-2})$$

$$V_{out} = 3.9524 - 3.3230 \cdot \log\left(\frac{F_{meas}}{50.3285}\right) \quad (\text{A-3})$$

$$V_{out} = 4.2176 - 2.9646 \cdot \log\left(\frac{F_{meas}}{56.8701}\right) \quad (\text{A-4})$$

$$V_{out} = 6.0968 - 2.0331 \cdot \log\left(\frac{F_{meas}}{50.0658}\right) \quad (\text{A-5})$$

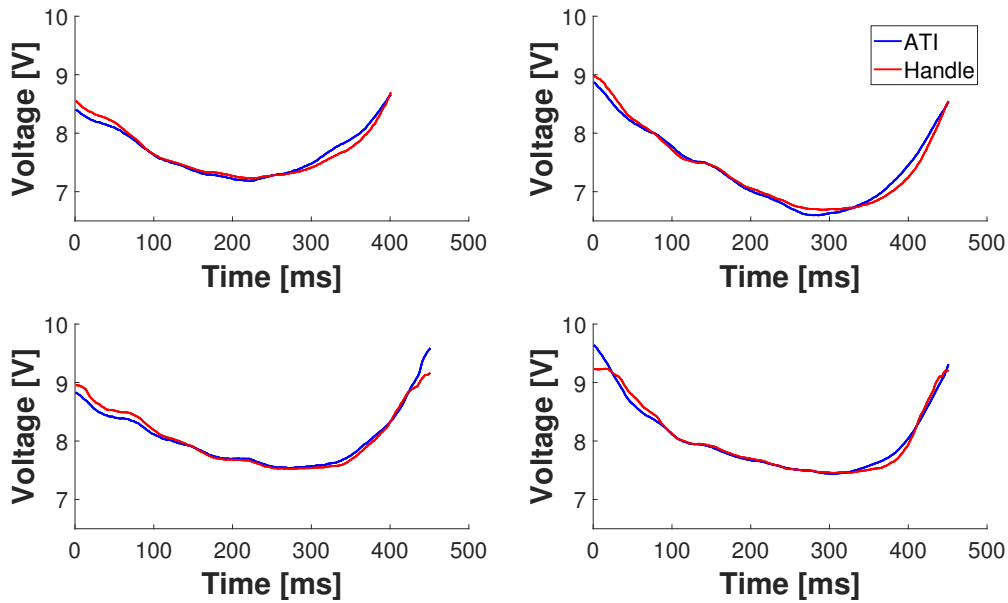

**Figure A-9:** ATI measurement transformed from Newtons to Voltage. Each figure represents a different handle plate.

To map the other way, FlexiForce signal into Newtons (ATI), a lookup table is used. The strain gauges were calibrated in an identical way.

## A-5 Current handle design

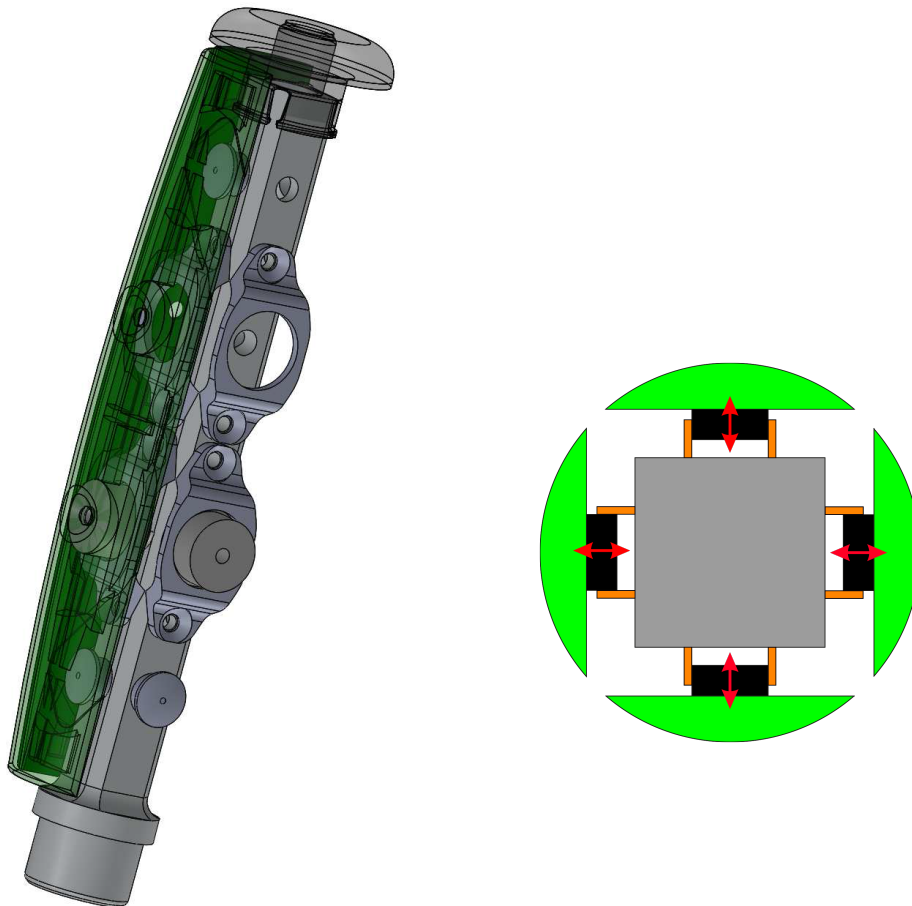

(a) 3D Solidworks joystick handle design      (b) Schematic cross-section of handle design

**Figure A-10:** Tekscan FlexiForce A301 provided information.

The current design uses 4 plates, one on each quadrant of the x-y plane (see Figure A-10b), and 2 electrical pressure sensors per plate to measure the applied grip force. Similar to a conventional grip dynamometer the movement of the plate is restricted to one translation orthogonal to the center of the handle shaft. In order to restrict movement of the plates in the other directions. The handle plates are mounted on rubber pucks, who are constrained to only translate perpendicular to the center of the handle, by plastic brackets. (see Figure A-10a) Between each plate and the center-rod there are 2 pressure tables. These are located above and below the mounting brackets/pucks. The pressure tables restrict inward movement of the handle-plate and thereby apply a normal force countering the grip force. Between the pressure table and handle plate are electronic pressure sensors. For these Flexiforce sensors to work, the surface area that applies this force, must be able to displace (albeit in order

of microns). Ideally the handle plates themselves are infinitely rigid so they do not bend or twist as this requires force and isn't registered. Unfortunately this is not possible and due to limitations in inertia they will stay 'somewhat' flexible.

## Disadvantages

In the current design the handle plate moves, towards the center of the handle. Due to the surface roughness of the pucks and alignment brackets (see Figure A-10a), this displacement causes friction in the opposite direction. Furthermore this friction increases if a moment is applied on the plates. Thus for any non-perpendicular and/or uneven distributed force on the plates, result in a increase of the normal force on the brackets and thus an increasing of the friction. Besides friction, the rubber pucks are held in place by metal springs. These spring forces, although low due to small displacement, must also be exceeded to be able to apply forces on the pressure tables.

$$F_s \leq \mu_s \cdot F_N \quad (\text{A-6})$$

## Improvement

To reduce the friction component in the grip measurement. I purpose to use the bending of the handle plate itself as this is already present and is typically hard/expensive to reduce to insignificant values. By placing a strain gauge on the bottom of a handle plate and fixating this plate to the joystick at the start and the end with a rigid connection. Non perpendicular forces are redirected to the joystick via the top and bottom connection. Bending sideways will be significantly harder due to the difference in width vs thickness. And forces perpendicular to the handle result in a slight bending of the plate. This way a minimum of only 4 strain gauges are required and no extra friction/ component are added to the signal.

From Marcel Thomas' website:

$$\frac{\delta_{max}}{L} \approx \frac{\sigma_{max}}{E} \cdot \frac{L}{h} \quad (\text{A-7})$$

The plates in the current design are roughly 12 cm long and 1 cm thick. For plastics  $\frac{\sigma_{max}}{E} \approx 10^{-2}$ . This means the maximum bending (displacement) will be:

$$\frac{\delta_{max}}{12} \approx 10^{-2} \cdot \frac{12}{1} \approx \frac{12}{100} \quad (\text{A-8})$$

Which leads to a maximum displacement of around 1.44 cm. However this is for a translation

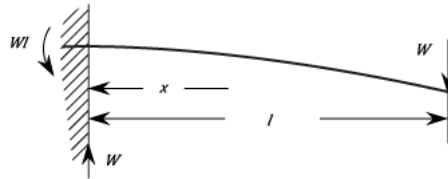

**Figure A-11:** Cantilever.

between the endpoints. We are interested in bending with fixed endpoints. Bending with fixed ends will (at least) half the deflection. Making it 7.2 mm of maximum bending deflection. This is way more than needed. If a strain gauge is used the fixation of the plates can be done at the top and bottom without and need for displacements. This leaves a lot more room for stiffening up the handle plates.

## Strain Gauge

Fundamentally, all strain gauges are designed to convert mechanical motion into an electronic signal. A change in capacitance, inductance, or resistance is proportional to the strain experienced by the sensor. If a wire is held under tension, it gets slightly longer and its cross-sectional area is reduced. This changes its resistance (R) in proportion to the strain sensitivity (S) of the wire's resistance. When a strain is introduced, the strain sensitivity, which is also called the gauge factor (GF), is given by:

$$GF = \frac{\Delta R/R_0}{\Delta L/L_0} = \frac{\Delta R/R_0}{\epsilon} \quad (\text{A-9})$$

Typical values for strain are less than 0.5 micrometer/mm. As can be seen in Figure A-12,

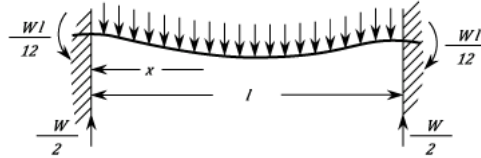

**Figure A-12:** Beam Bending.

the bending of a beam supported on both ends depicts a wave form. If we cut this beam at  $X = L/4$ ,  $L/4$  and  $3L/4$  of the wave, we end up with 4 cantilevers. Since the bending moment is highest at the beginning of a cantilever. The highest bending moment is found at  $x = 0$ ,  $x = L$  and  $x = L/2$ .

The strain at the surface due to the bending of the beam is equal to:

$$\epsilon = \frac{M \cdot \text{thickness}}{2EI} \quad (\text{A-10})$$

In this case that leads to  $M = 125 \cdot 0.06$ ,  $I = \frac{bh^3}{12} = \frac{3 \cdot 0.5^3}{12} = 0.03125$  &  $E \approx 2GPa$

$$\epsilon_{max} = \frac{2083.333 \cdot 1}{2 \cdot 0.03125 \cdot 200000} = 0.1666 \quad (\text{A-11})$$

$$\epsilon_{10N} = \frac{166.666 \cdot 1}{2 \cdot 0.03125 \cdot 200000} = 0.0133 \quad (\text{A-12})$$

This is well within the range of a strain gauge and quite possibly a good improvement for the existing flexiforce pressure sensors.



## Experiment Visualization

### B-1 Task Visualization

The visualization of the experiment was done using Matlab. A script running at 30 Hz drew the path, a red dot marking the position of the joystick, a small blue line the center of the path and large white bars representing the obstacles. About 3 seconds of information is displayed at a time on the monitor. The entire path is a little under 3 min. Small horizontal lines on the left and right side of the screen moving downwards, enhanced the illusion of forward (upward) motion.

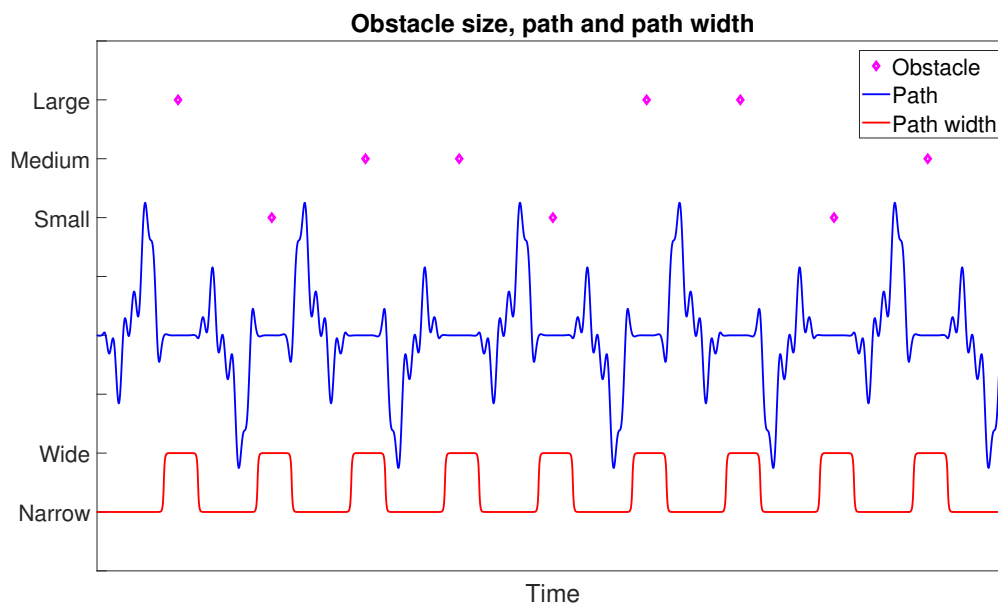

**Figure B-1:** Visualization information. (only one of the three used obstacle order is represented)

## B-2 Van-Der-Laan Questionnaire

After the HSC and AHSC the participants was asked to digitally fill the VDL questionnaire. Participants are asked to give their opinion on the just used support mode, comparing it to manual control. The questionnaire is a 5 point likert scale represented by 5 small vertical bars. Participants could move the blue bar to the left and right to indicate their answer.

What did you think of the (A)HSC support mode on the joystick?

Questionair

useful useless

Q1

pleasant unpleasant

Q2

bad good

Q3

nice annoying

Q4

effective superfluous

Q5

irritating likable

Q6

assisting worthless

Q7

undesirable desirable

Q8

raising alertness sleep-inducing

Q9

Panel

subject no.:

Figure B-2: Visualization of the digital van-der-Laan questionnaire



---

# Appendix C

---

## Experimental Protocol & Informed Consent

### C-1 Experimental Protocol

Thank you very much for considering to participate in this experiment. Below is the description of the tasks to be performed during the experiment and some safety considerations. If any statement is unclear, please do not hesitate to ask the experimenter.

The purpose of this experiment is to investigate if grip force is a useful parameter to use for continuously adaptation of a haptic shared control system during a position control task. This means that for this experiment, **the assisting forces** applied by the haptic shared control system will **decrease** based on the grip force. We are investigating this by using an actuated joystick named "TriaR".

During this experiment, the joystick can **only be rotated to the left and right**. (forwards and backwards have been disabled as well as axial rotations).

Now let me explain what the experiment entails.

You will be seated behind the TriaR and a PC monitor. See Figure C-1a.

Make sure you are comfortable and are able to rotate the joystick to its limits without letting go of the handle. You'll be asked to place your hand on the handle of the joystick in a similar way as shown in Figure C-1b. Please make sure your knuckle-bone is aligned with the red line on top of one of the 4 green handle plates. It is important that you do not let go of the handle during a trial.

The experiment will start with a short familiarization sessions that will let you experience how the joystick feels and how the red target reacts to displacements.

After this familiarization session the actual experiment starts.

There will be 3 trials, 1 with manual control, 1 with haptic shared control and 1 with adaptable haptic shared control. Each trials consist of 3 path tracking tasks including obstacle avoidance.

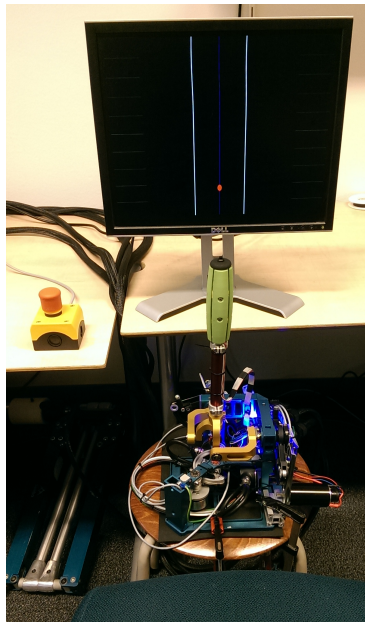

(a) Experimental Setup including TriaR and monitor.

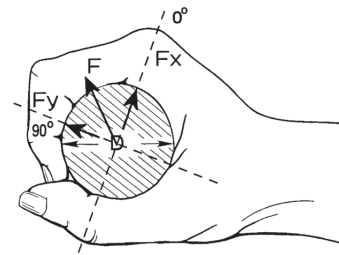

(b) Default handle grabbing orientation during experiment

**Figure C-1:** Experimental setup and grip orientation on handle.

Path tracking is done by controlling the horizontal position of the red dot. The red dot is controlled by using the joystick. The forward motion of the red dot along the path is fixed so your task is to follow the center (blue) line as accurate as possible. However, when an obstacle blocks the way of the center line you should navigate smoothly around this obstacle and when past the obstacle 'swiftly' return to the center line. During the 2 trials with the haptic shared controller activated, the automation will always guide you towards the center (blue) line. (even if it is blocked by an obstacle!) Each trial will take about 10-15 min and is followed by a van-der-laan questionnaire. (9 questions)

Between trials there is the possibility for a small break if needed.

If you have any questions regarding the experiment protocol, please do not hesitate and ask the experimenter directly. If you have any questions about this experiment after your participation, please contact Joost Hilte (jhilte@gmail.com).

If you do not have further questions and feel ready to do the experiment, please do sign the informed consent before the actual experiment.

## C-2 Informed Consent - Adaptable Haptic Shared Control

Dear participant,

You have been asked to participate in a study on "Adaptable Haptic Shared Control". The research is conducted by Joost Hilte, under supervision of David Abbink. In this study we are interested if grip force can be used to continuously adapt a haptic shared control system.

You will be seated behind an actuated joystick. This joystick controls the lateral position of a red marker on the PC monitor. You will be asked to control the red marker and follow the blue line. In this study the forward speed has been set to a constant speed. Therefore only left and right motion is required. The system will be in position control, this means the horizontal joystick position directly determines the horizontal marker position. Your goal is to follow the blue line (path) as accurate as possible. The path also contains obstacles which must be avoided. When you encounter an obstacle you will have to leave the blue line and smoothly navigate around it. You will be asked to fill in a van der Laan questionnaire twice. The nine paths plus the two questionnaires will take approximately 30-45 minutes.

Your answers, as well as position and force data of the devices are recorded. These recordings are used anonymously. Personal data is not available to persons other than the researchers. The only directly identifiable data (such as name, address, telephone number, and so on) that is kept longer than 6 months is the information on this informed consent form. Participation in this study is voluntary. In the experiment you can be exposed to forces up to 15 N. If due to these forces, or due to any other reason, you feel any form of discomfort during the experiment, please inform the experimental leader. You are free to quit the experiment at any time. For questions after the study, please contact Joost Hilte (jhilte@gmail.com).

I, the undersigned, declare to have read and understood the information about the project, the use of data and to consent to the experiment.

Name \_\_\_\_\_

Location \_\_\_\_\_

Gender \_\_\_\_\_

Date \_\_\_\_\_

Age \_\_\_\_\_

Left/Right  
Handed \_\_\_\_\_

Signature \_\_\_\_\_



---

# Appendix D

---

## Data

The following 18 pages show the data per participant followed by the group average. It can be seen that when participants exert enough grip force during Adaptable Haptic Shared Control (AHSC), the torques highly resemble those during Manual (MAN) control ('S' curve). A Level of Haptic Authority (LoHA) transition from high (Haptic Shared Control (HSC)) to low (MAN) is initiated and controlled by the human. Furthermore, once the obstacle is passed, a lot of participants quickly reduce their grip force resulting to a rapid increase of the assisting forces towards the center of the path. This helps them quickly move back to the center but also results in overshoot. Participant 8 and 17 barely used the AHSC to adapt the LoHA. For participant 8 this seems like a consistent decision whereas for 17 this might be due to a language barrier between participant and experimenter, as it was a struggle to explain the experiment. It can be seen that participant 17 did increase their grip force during regular HSC but barely during AHSC. Without exception, for each participant the HSC and AHSC decreased the lateral deviation during the multisine path following task.

## Participant 1

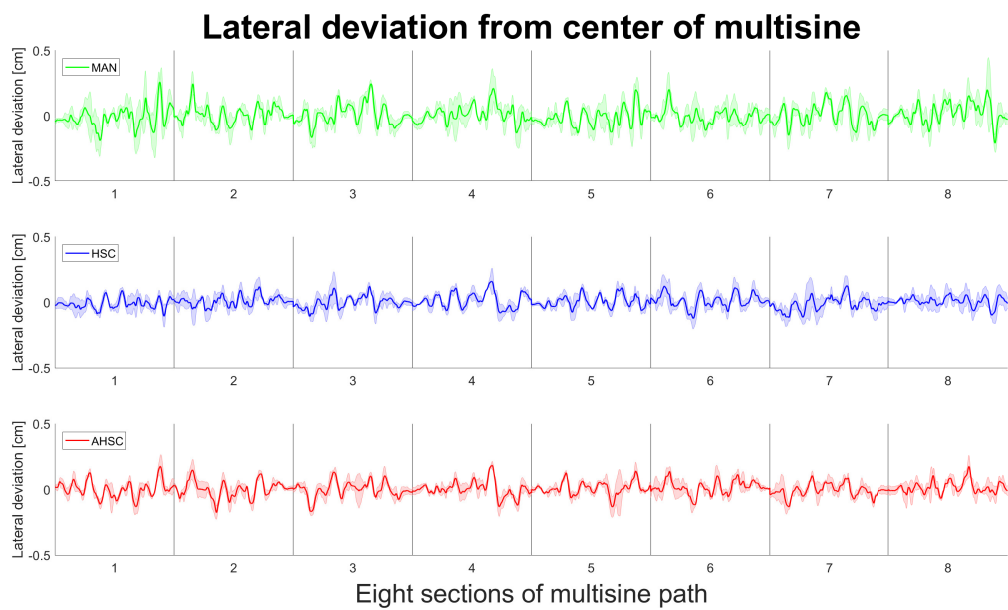
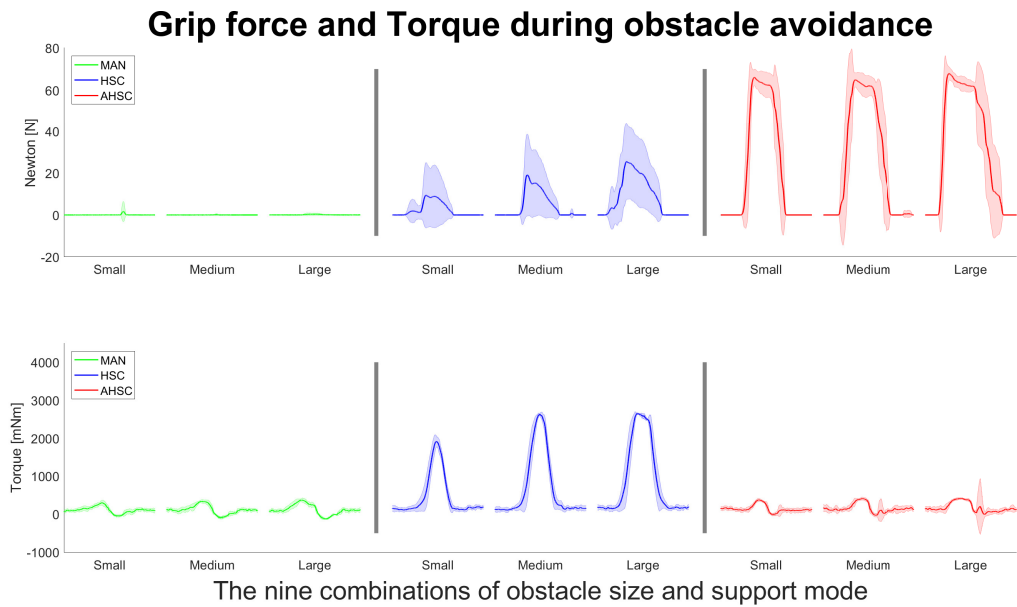

**Figure D-1:** Data participant 1

## Participant 2

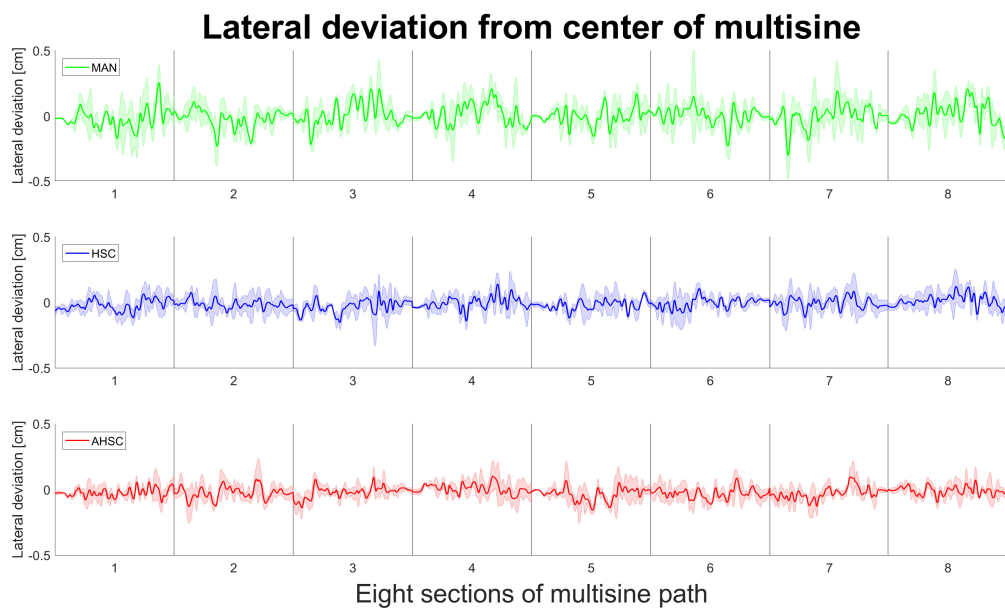
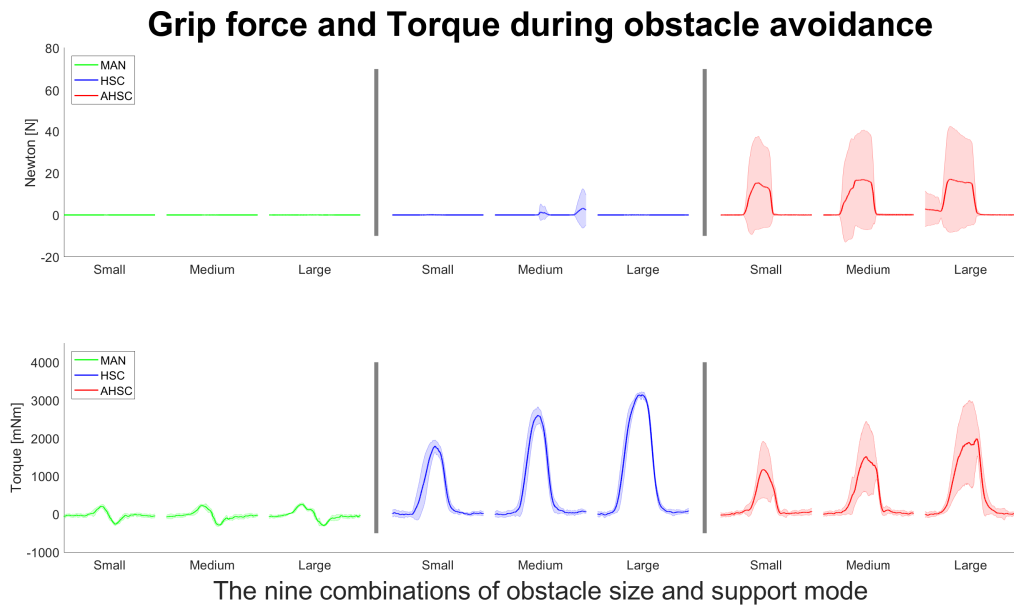

**Figure D-2: Data participant 2**

## Participant 3

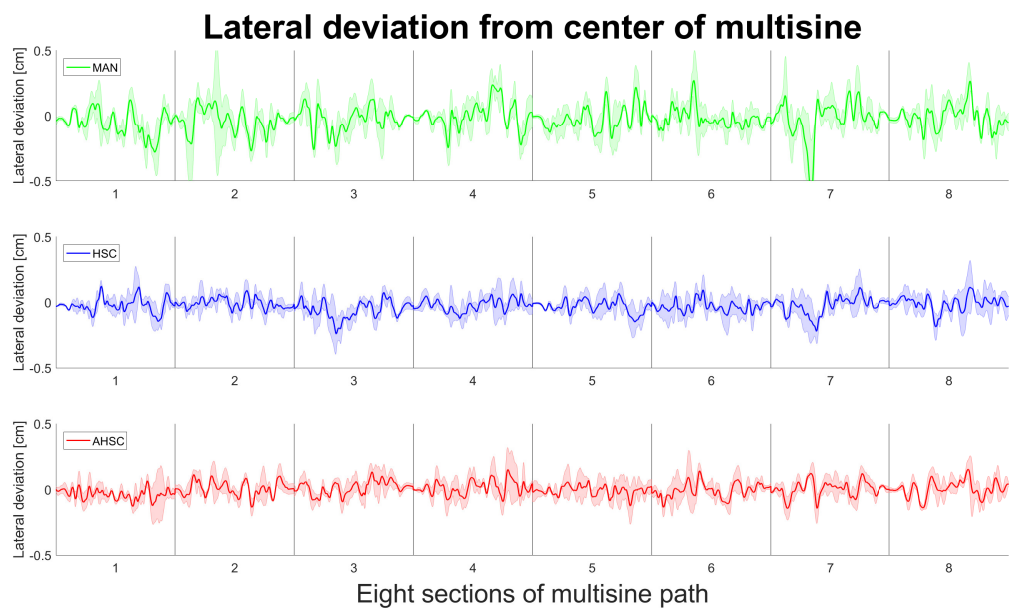
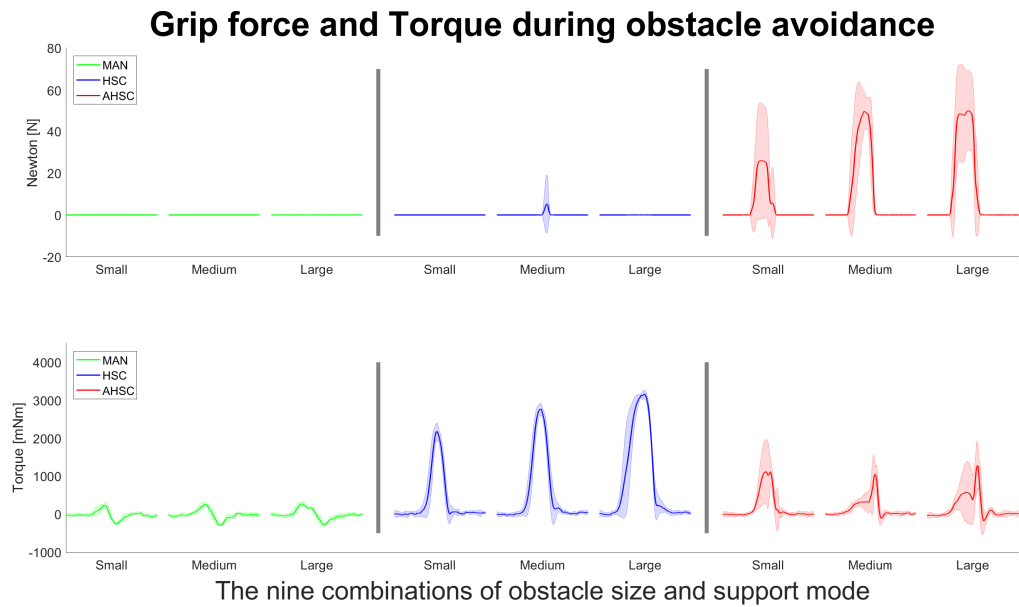
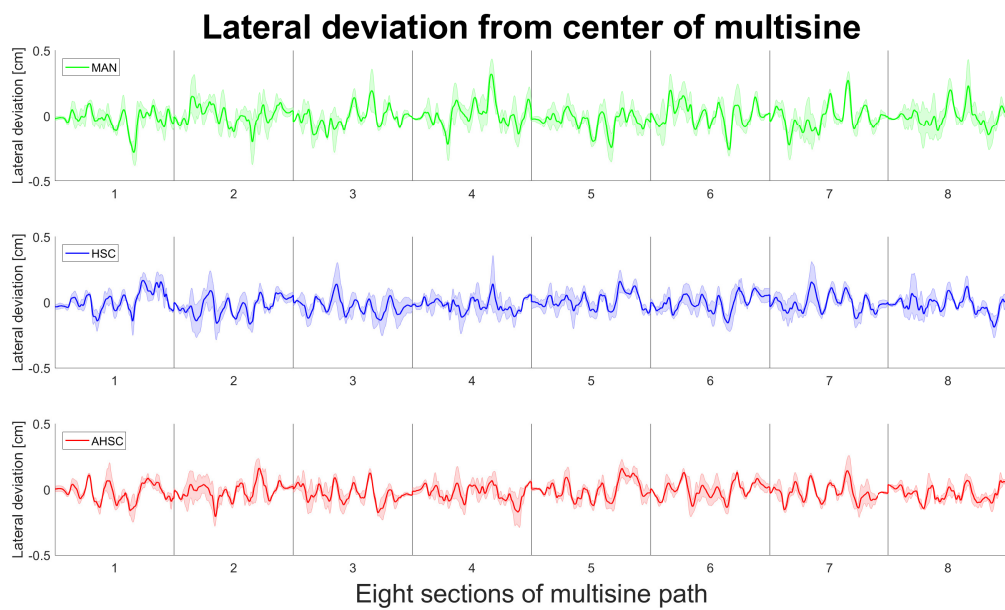
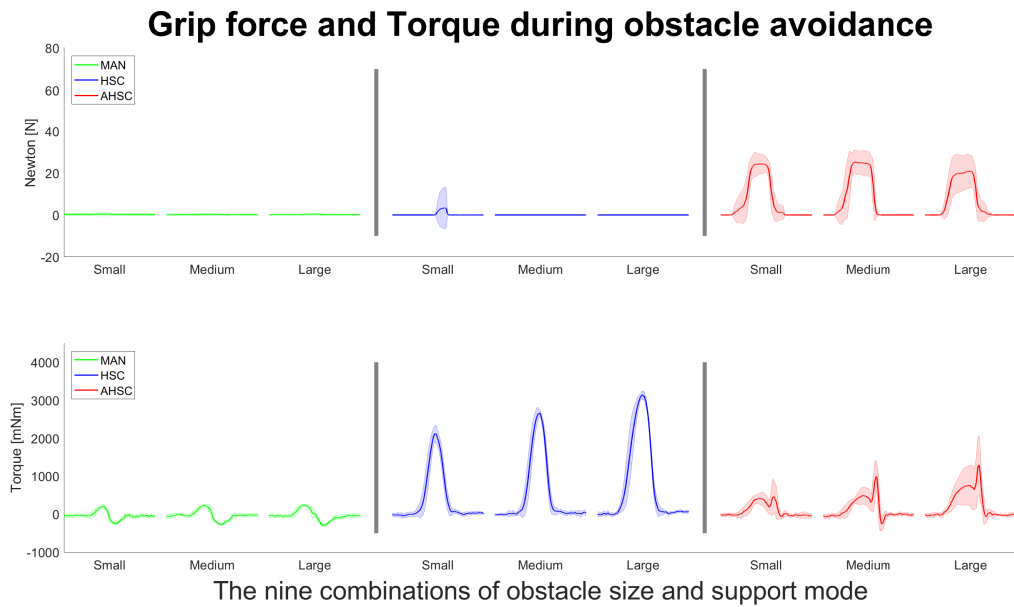

Figure D-3: Data participant 3



## Participant 4



**Figure D-4:** Data participant 4

## Participant 5

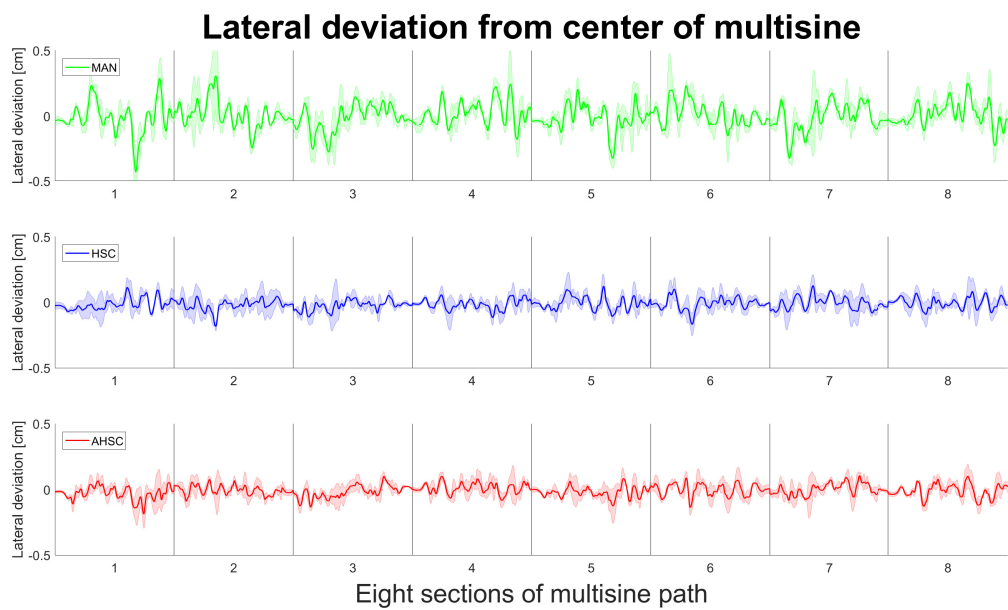
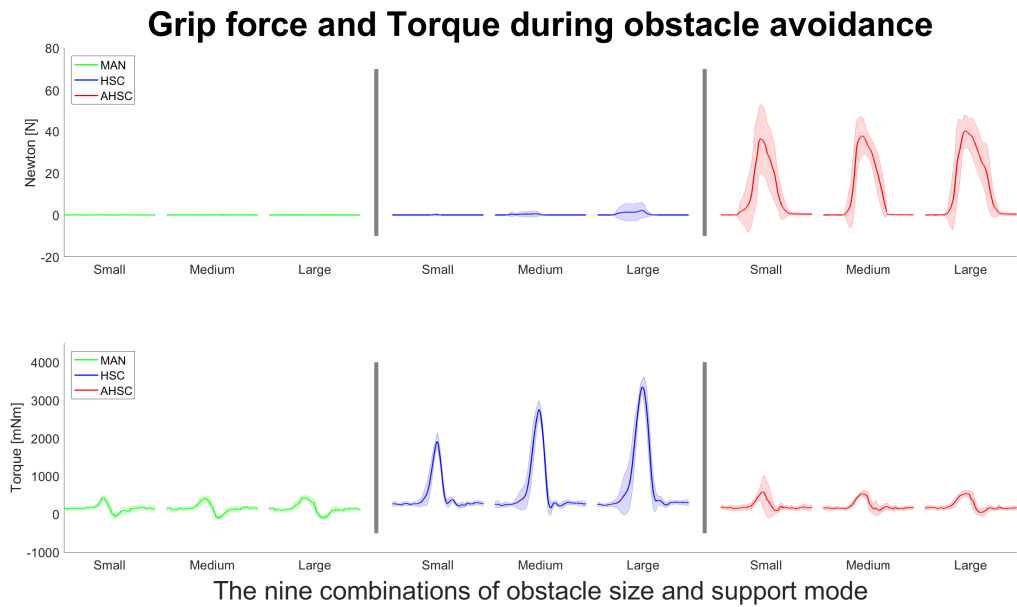

**Figure D-5:** Data participant 5

## Participant 6

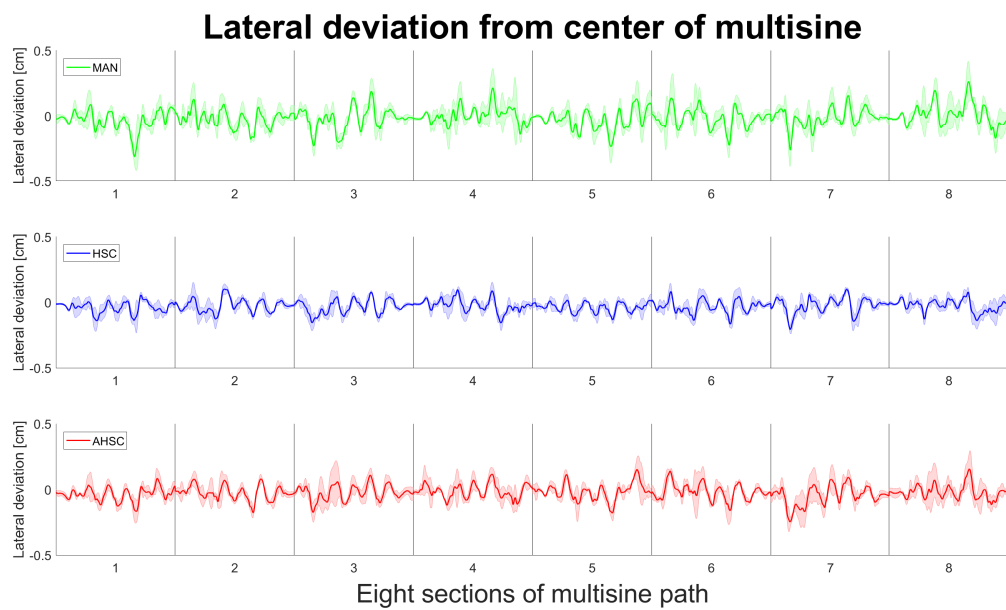
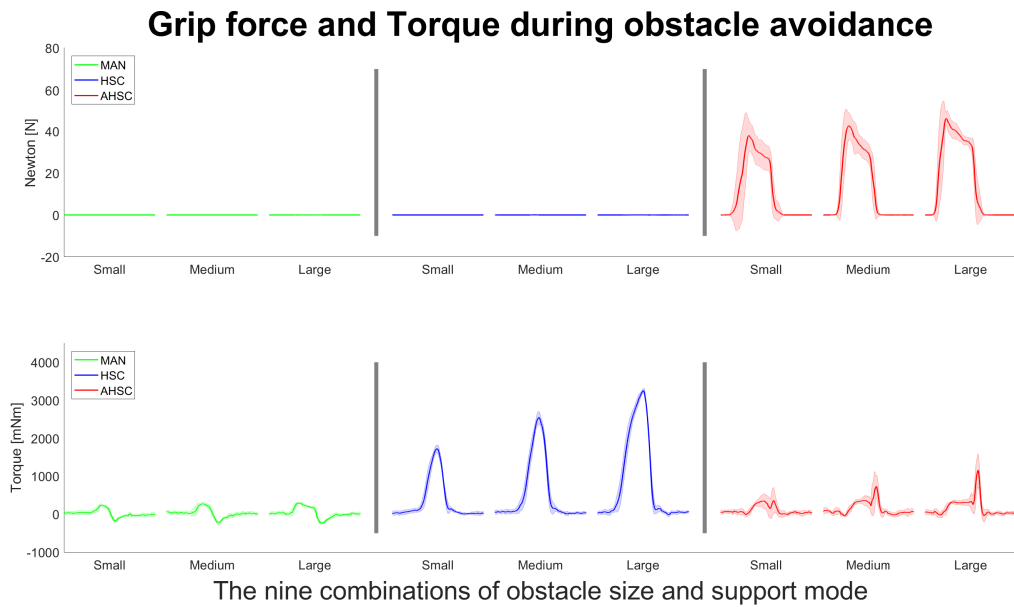
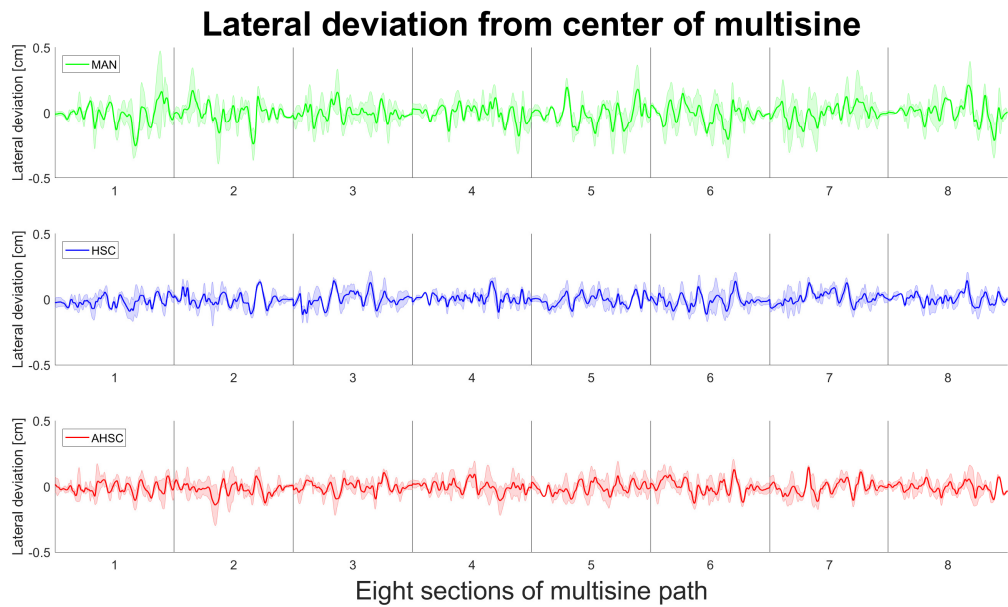
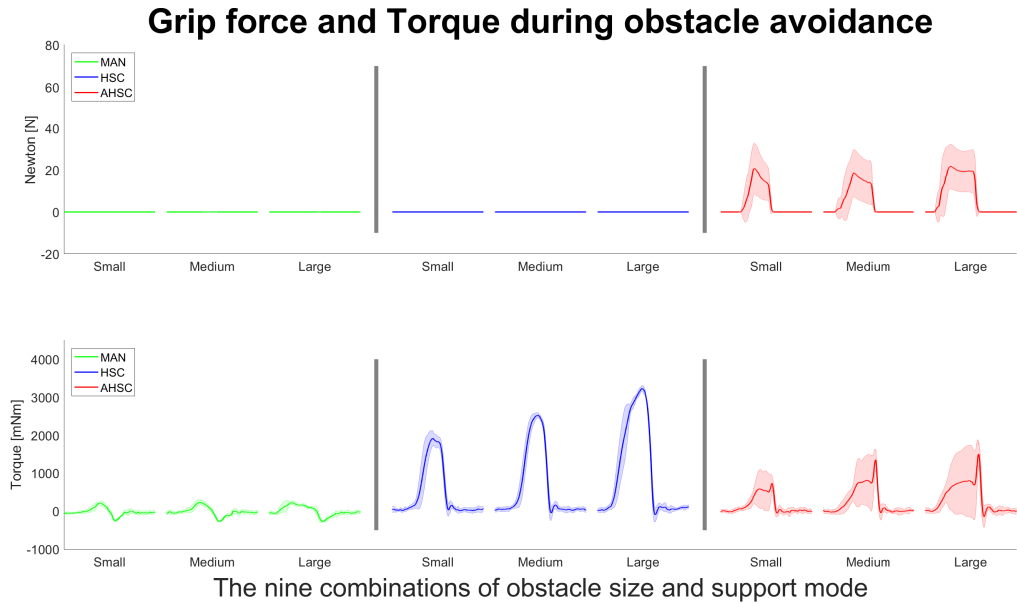

Figure D-6: Data participant 6

## Participant 7



**Figure D-7:** Data participant 7

## Participant 8

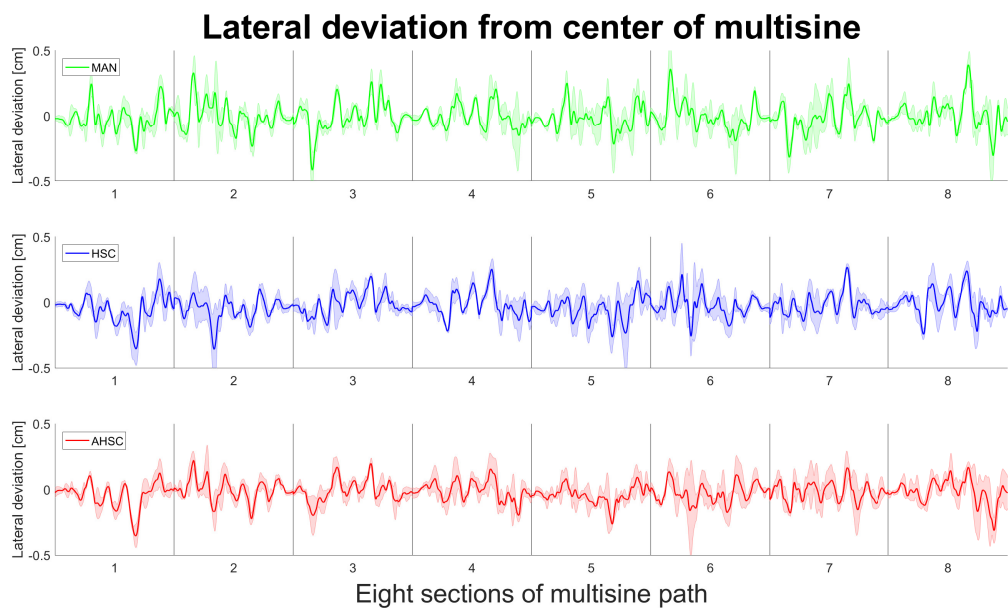
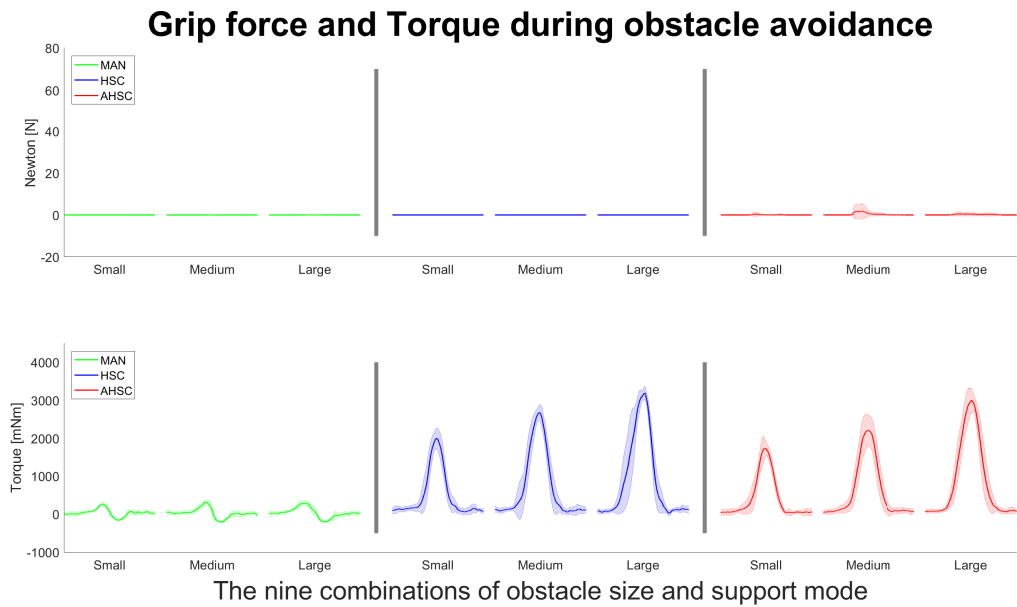

Figure D-8: Data participant 8

## Participant 9

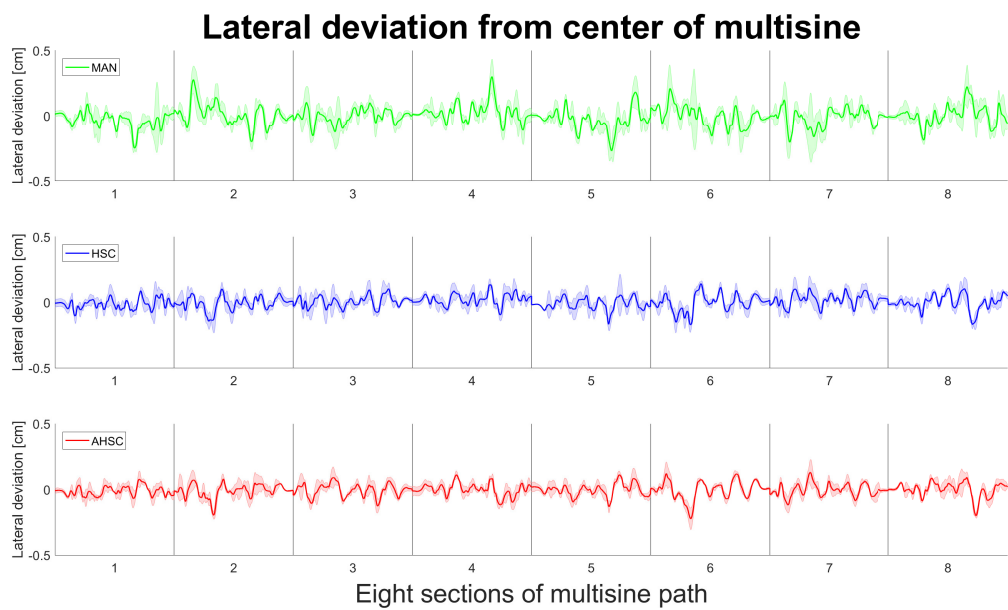
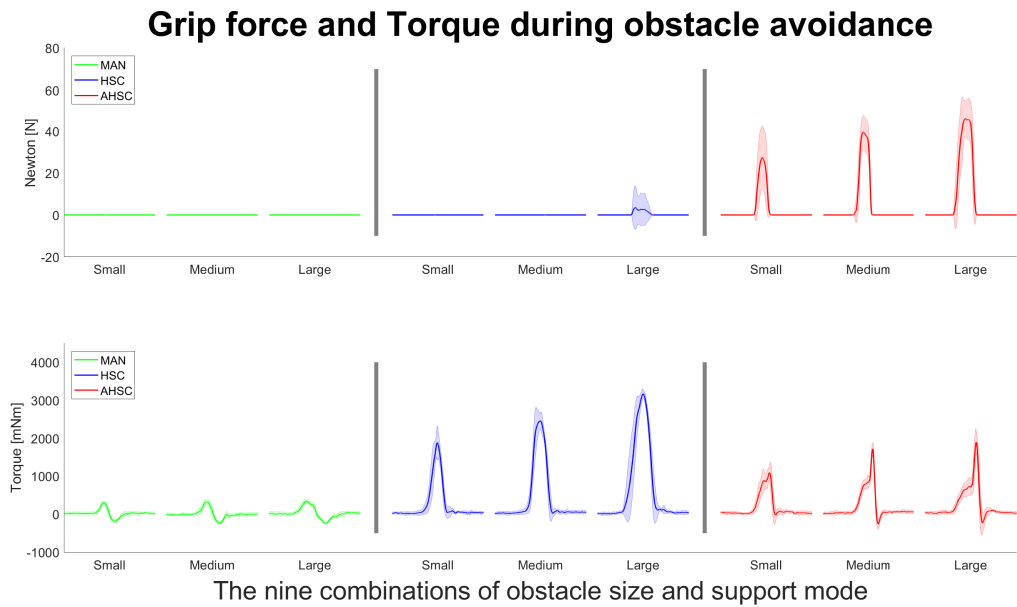

Figure D-9: Data participant 9

## Participant 10

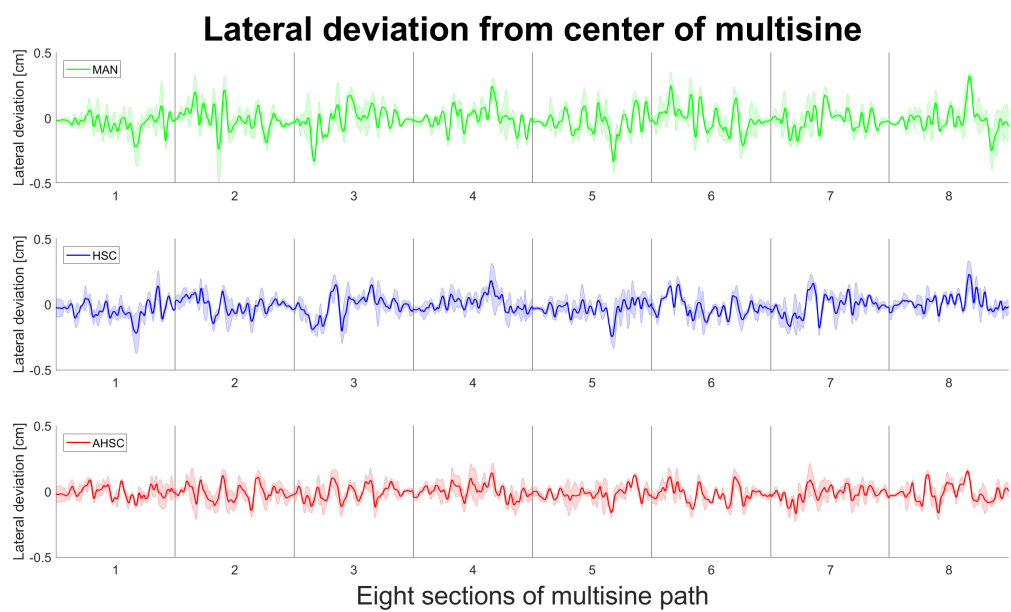
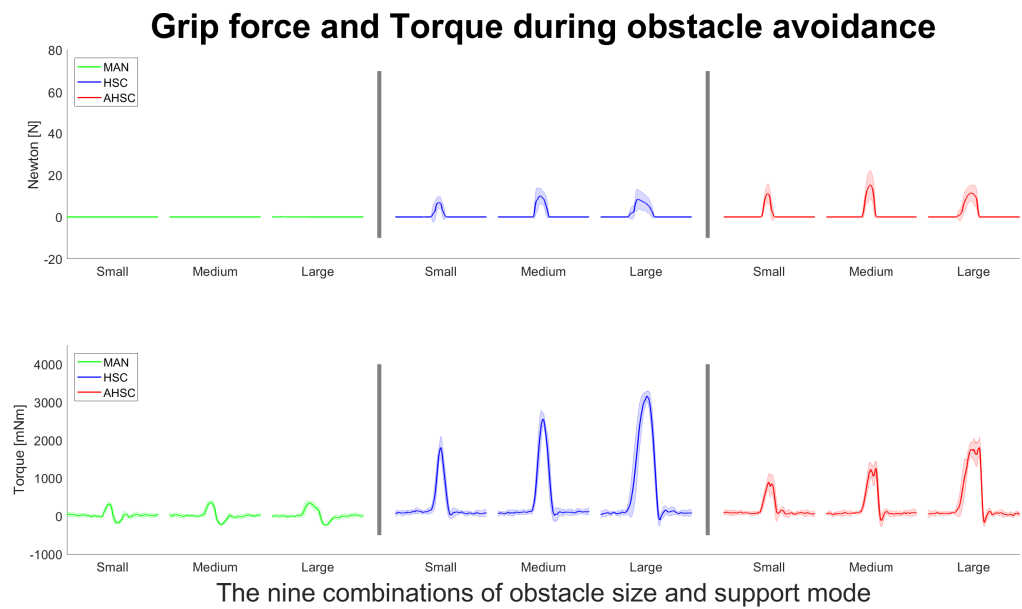
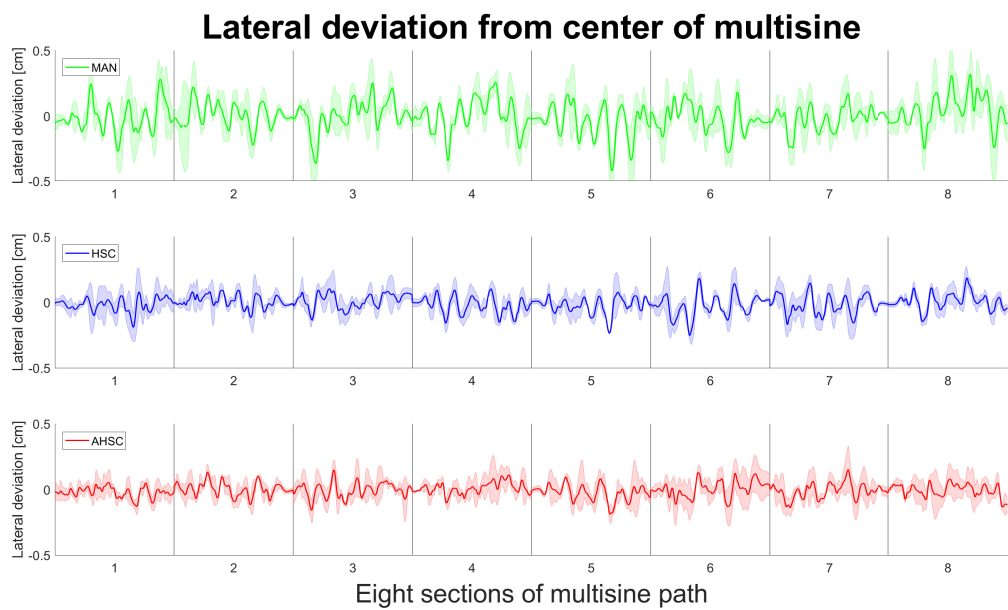
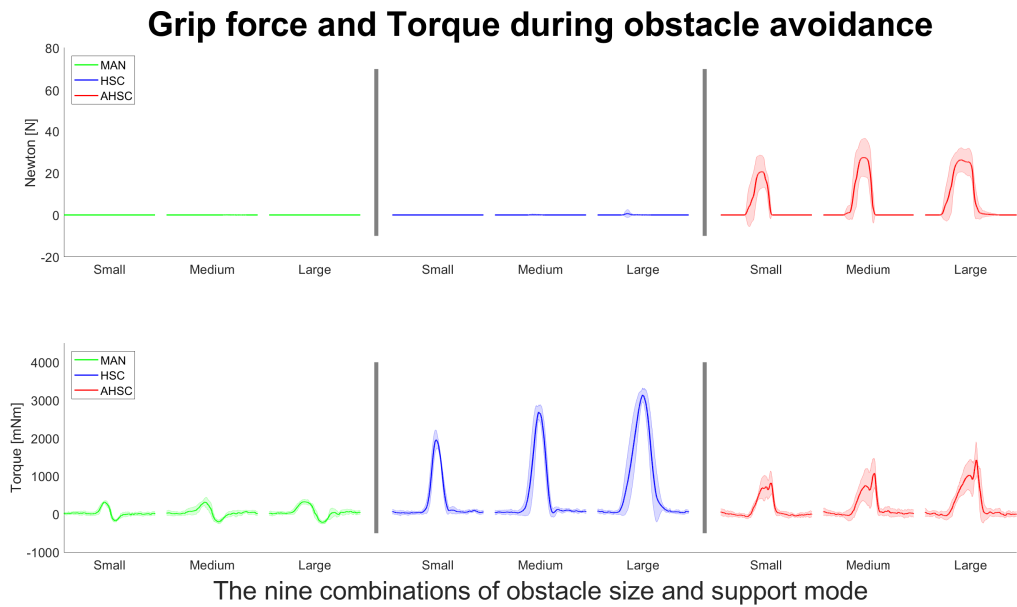

Figure D-10: Data participant 10

## Participant 11



**Figure D-11:** Data participant 11



## Participant 12

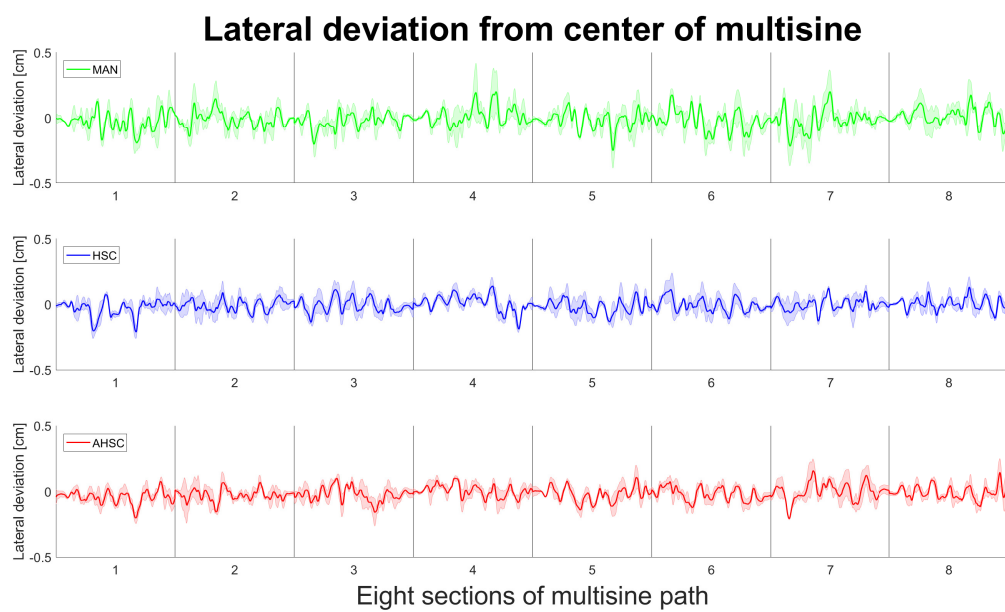
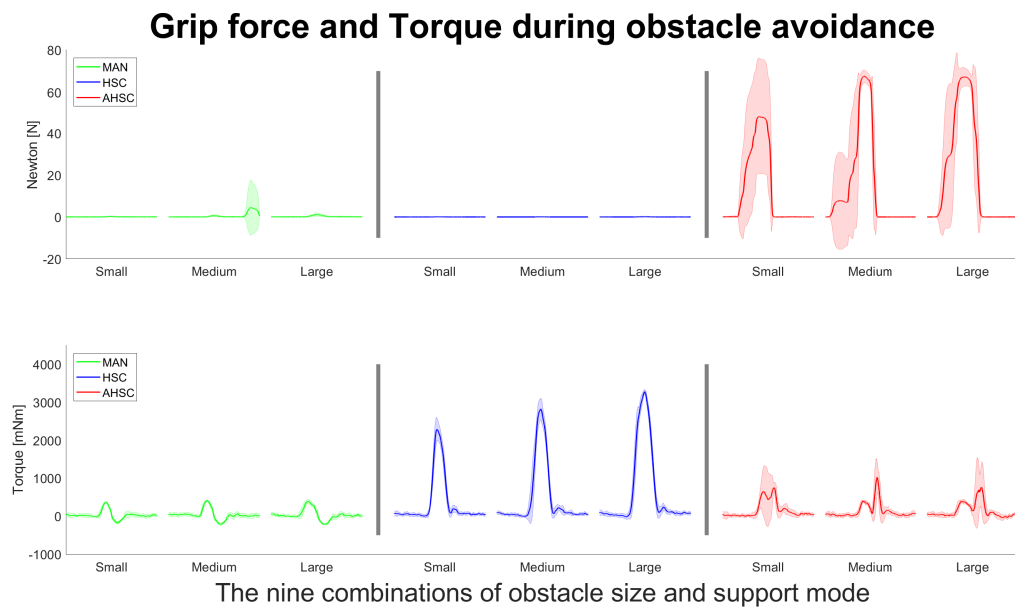

**Figure D-12:** Data participant 12

## Participant 13

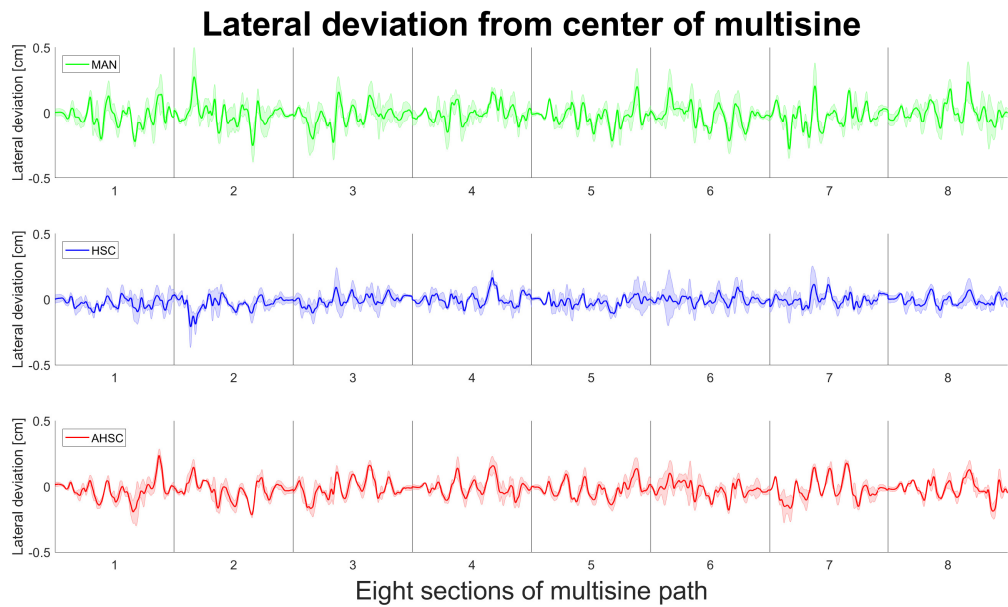
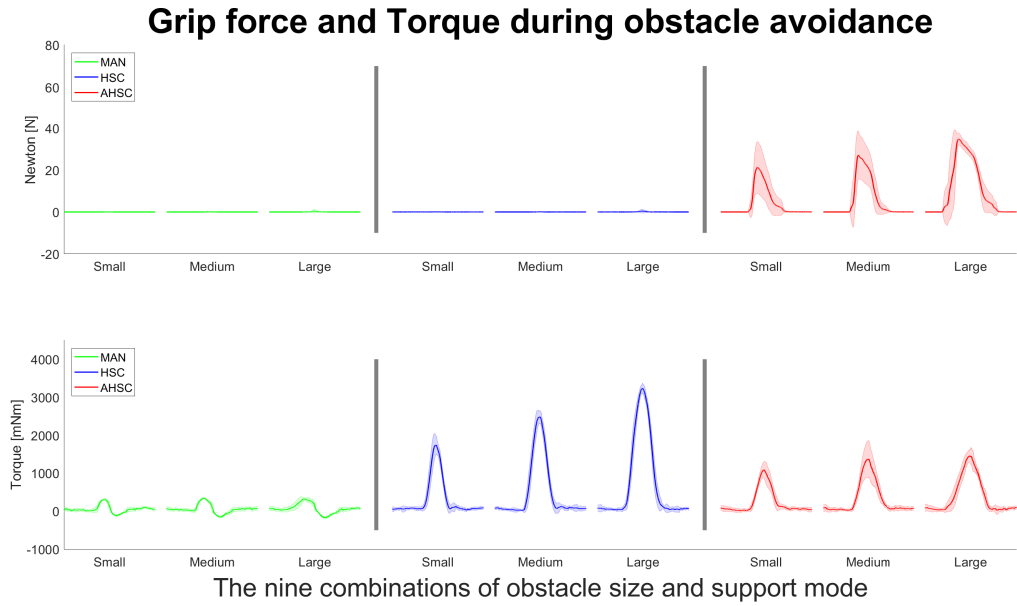

**Figure D-13:** Data participant 13

## Participant 14

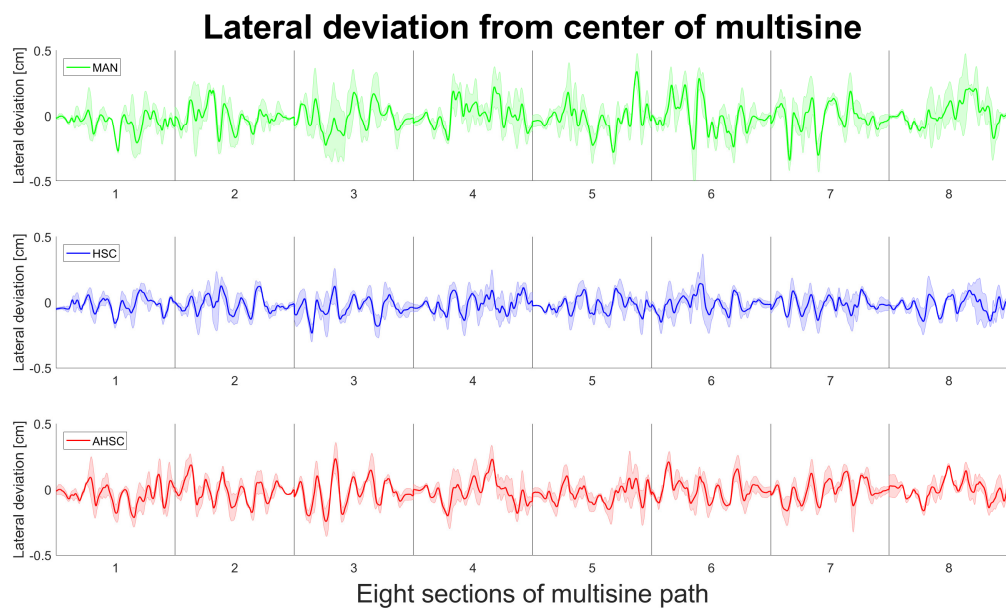
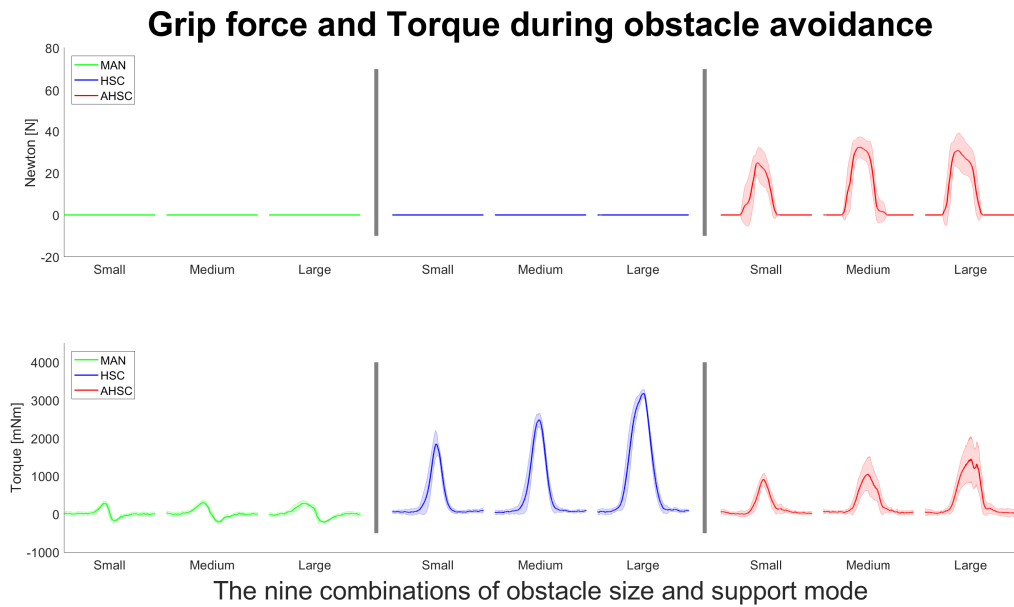

**Figure D-14:** Data participant 14

## Participant 15

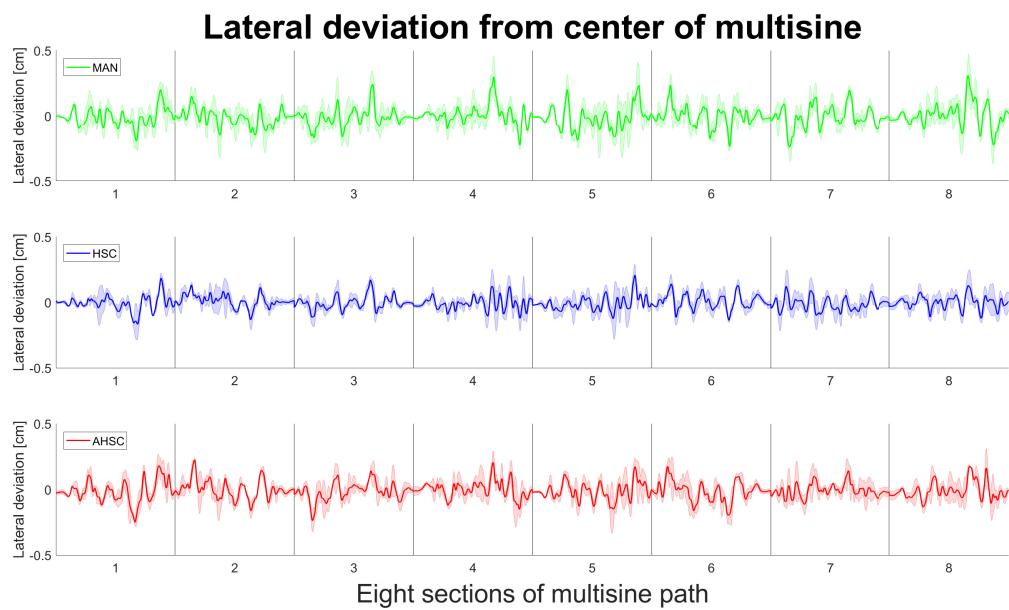
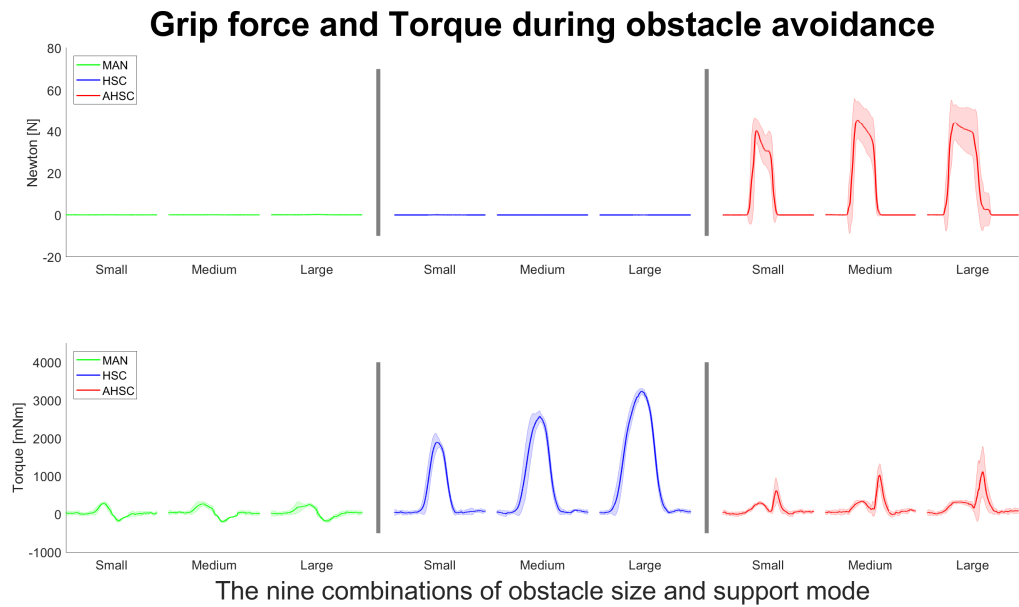

**Figure D-15: Data participant 15**

## Participant 16

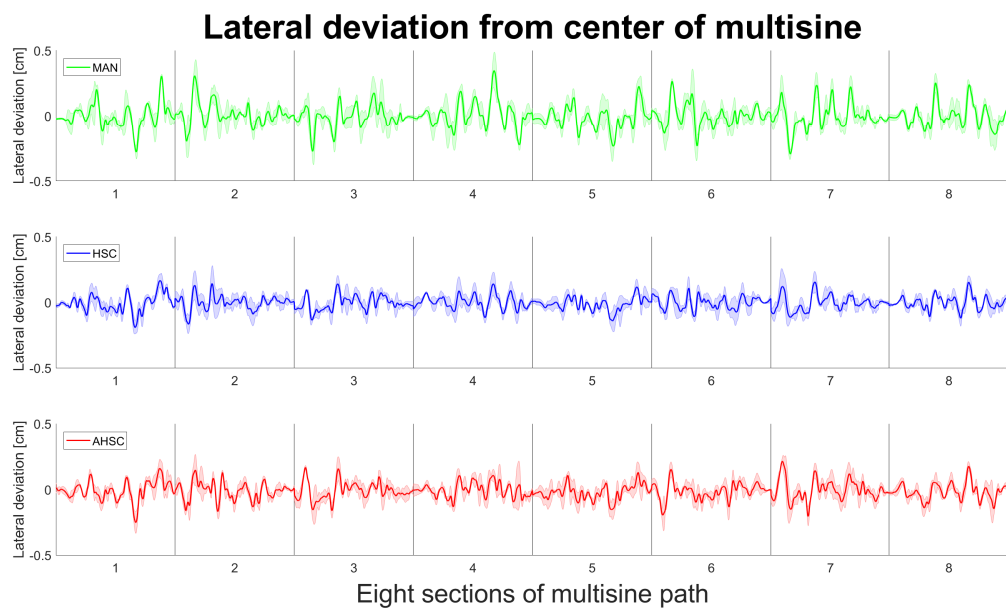
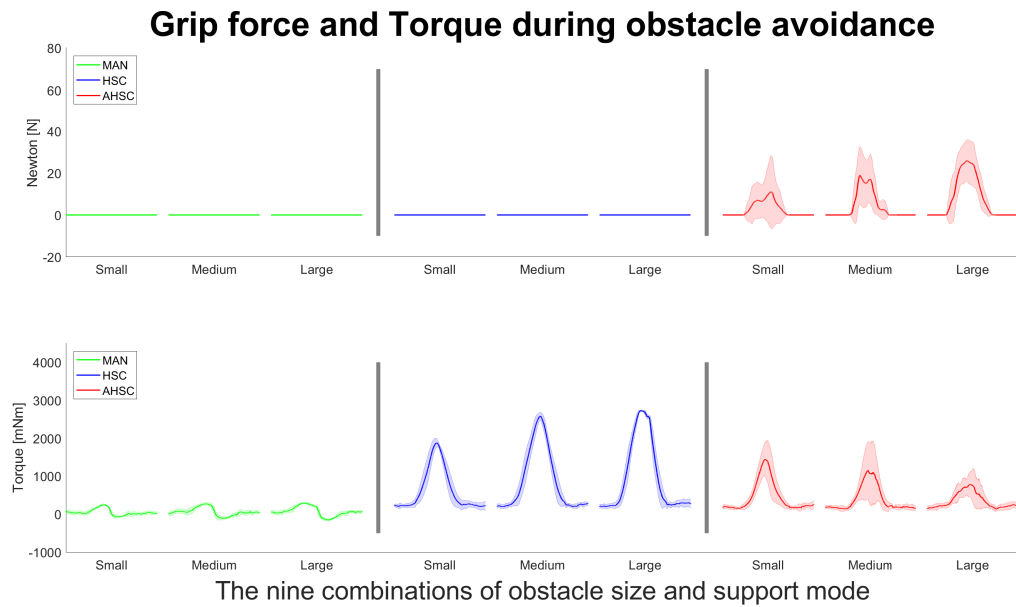

Figure D-16: Data participant 16

## Participant 17

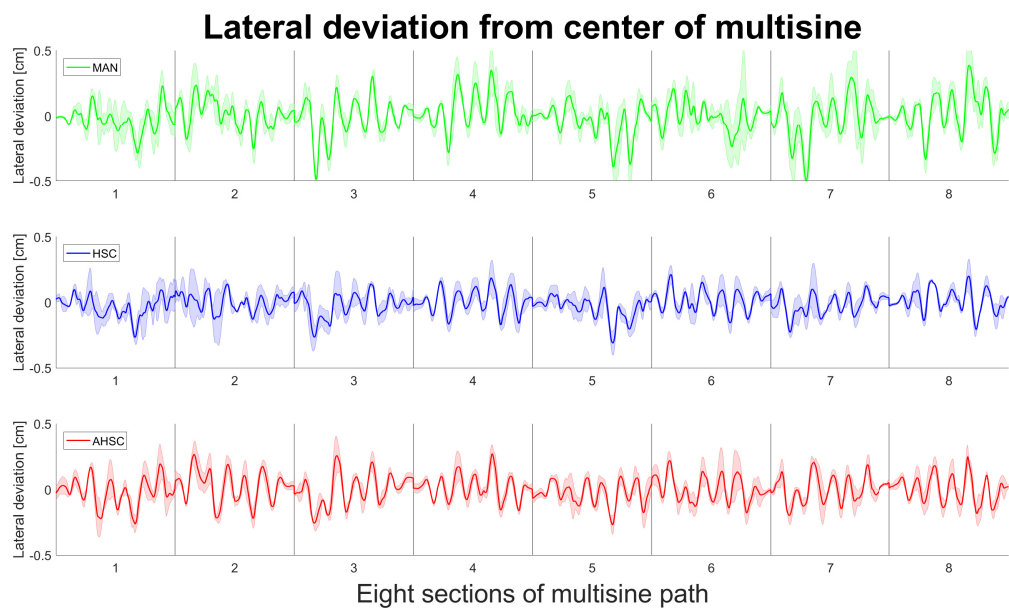
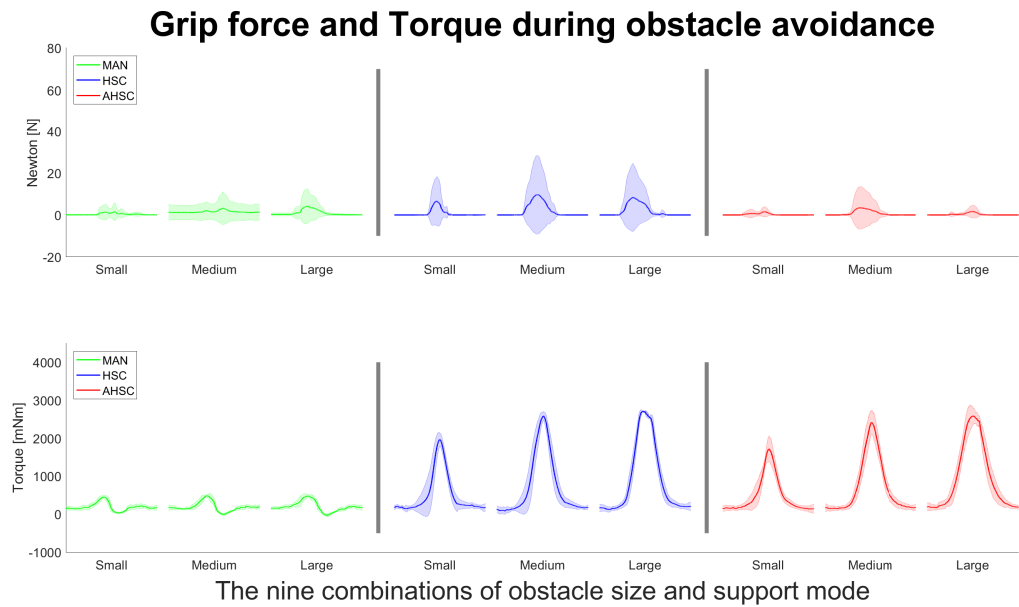
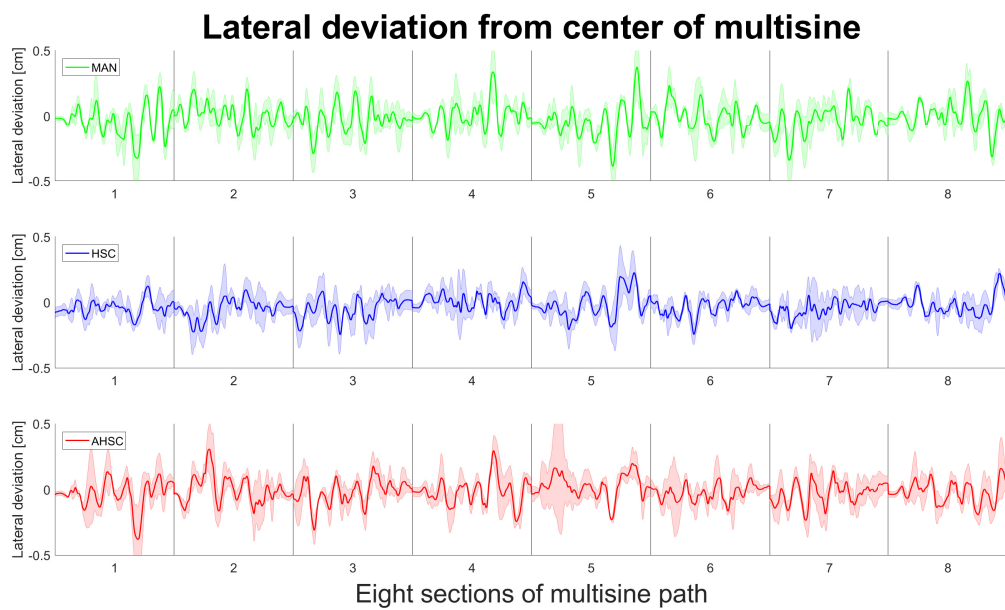
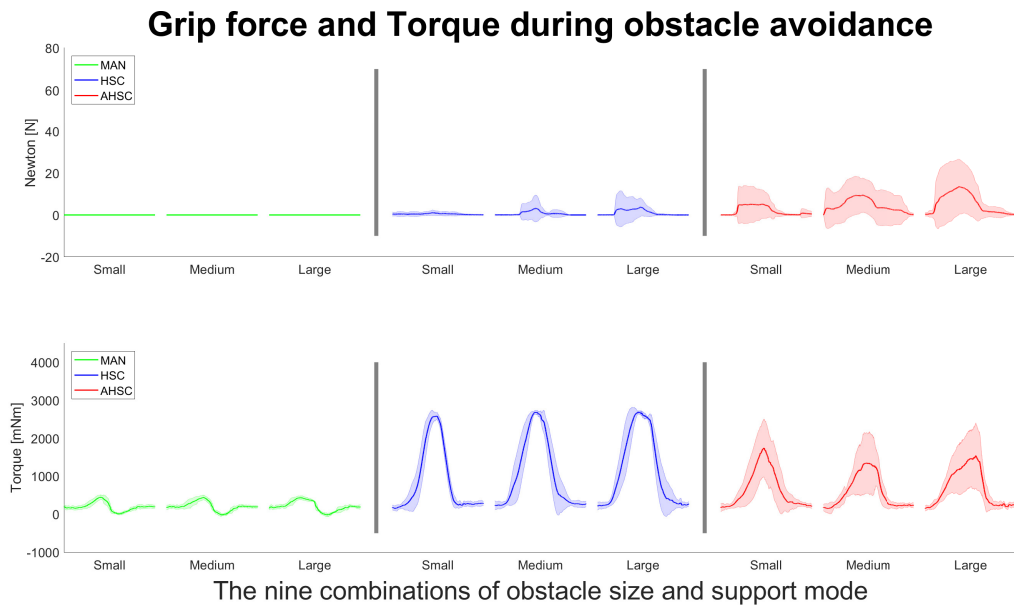

Figure D-17: Data participant 17

## Participant 18



**Figure D-18:** Data participant 18

## Group

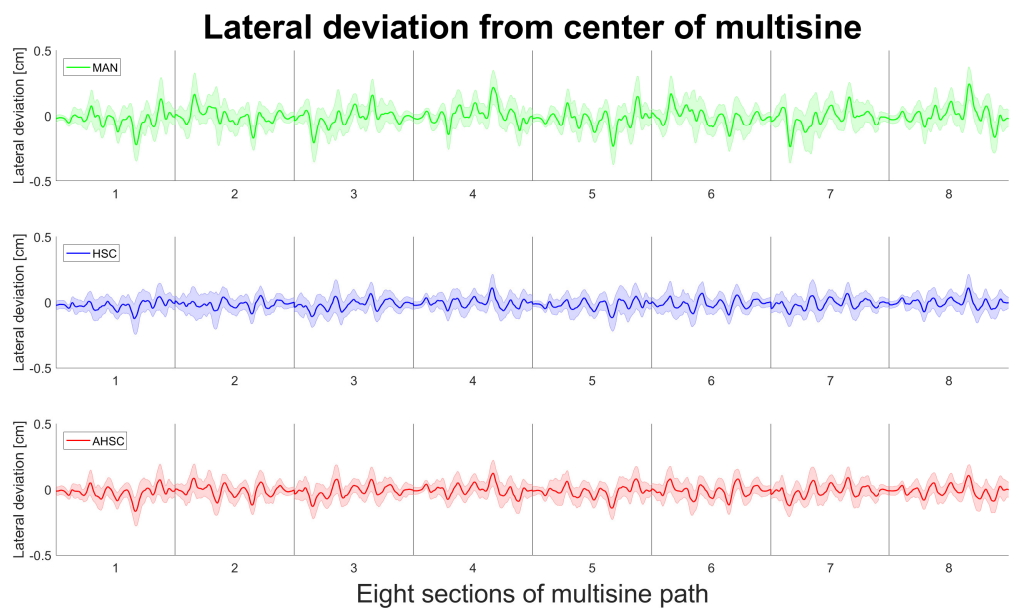
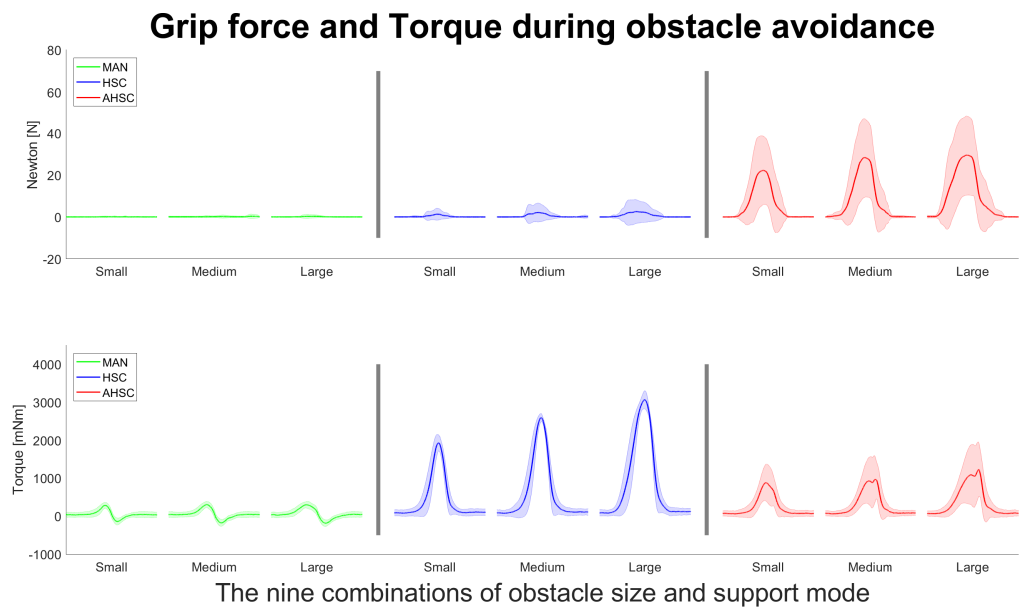

**Figure D-19:** Group data



---

# Bibliography

- [1] D. Abbink and M. Mulder, “Neuromuscular Analysis as a Guideline in designing Shared Control,” *Advances in Haptics*, pp. 499–517, 2010.
- [2] D. A. Abbink, M. Mulder, and E. R. Boer, “Haptic shared control: Smoothly shifting control authority?,” *Cognition, Technology and Work*, vol. 14, no. 1, pp. 19–28, 2012.
- [3] F. Flemisch, J. Kelsch, C. Löper, A. Schieben, and J. Schindler, “Automation spectrum , inner/outer compatibility and other potentially useful human factors concepts for assistance and automation,” *Human Factors for Assistance and Automation*, no. 2008, pp. 1–16, 2008.
- [4] J.-M. Hoc, “From human - machine interaction to human - machine cooperation,” *Ergonomics*, vol. 43, no. 7, pp. 833–843, 2000.
- [5] H. Nakamura, D. Abbink, and M. Mulder, “Is grip strength related to neuromuscular admittance during steering wheel control?,” *2011 IEEE International Conference on Systems, Man, and Cybernetics*, pp. 1658–1663, 2011.
- [6] D. A. Abbink, “Task instruction: The largest influence on human operator motion control dynamics,” *Proceedings - Second Joint EuroHaptics Conference and Symposium on Haptic Interfaces for Virtual Environment and Teleoperator Systems, World Haptics 2007*, pp. 206–211, 2007.
- [7] M. R. Cutkosky, “On Grasp Choice, Grasp Models, and the Design of Hands for Manufacturing Tasks,” *IEEE Transactions on Robotics and Automation*, vol. 5, no. 3, pp. 269–279, 1989.
- [8] J. Smisek, M. M. Van Paassen, M. Mulder, and D. a. Abbink, “Neuromuscular analysis based tuning of haptic shared control assistance for UAV collision avoidance,” *2013 World Haptics Conference, WHC 2013*, pp. 389–394, 2013.
- [9] D. Damböck, M. Kienle, K. Bengler, and H. Bubb, “The H-metaphor as an example for cooperative vehicle driving,” *Lecture Notes in Computer Science (including subseries*

- Lecture Notes in Artificial Intelligence and Lecture Notes in Bioinformatics*), vol. 6763 LNCS, no. PART 3, pp. 376–385, 2011.
- [10] J. D. Van Der Laan, A. Heino, and D. De Waard, “A simple procedure for the assessment of acceptance of advanced transport telematics,” *Transportation Research Part C: Emerging Technologies*, vol. 5, no. 1, pp. 1–10, 1997.
- [11] M. J. Castillo-Garzón, J. R. Ruiz, F. B. Ortega, and A. Gutiérrez, “Anti-aging therapy through fitness enhancement.,” *Clinical interventions in aging*, vol. 1, no. 3, pp. 213–220, 2006.
- [12] J. L. Morse, M.-C. Jung, G. R. Bashford, and M. S. Hallbeck, “Maximal dynamic grip force and wrist torque: The effects of gender, exertion direction, angular velocity, and wrist angle,” *Applied Ergonomics*, vol. 37, no. 6, pp. 737–742, 2006.
- [13] C. S. Edgren, R. G. Radwinx, and C. B. Irwin, “Grip force vectors for varying handle diameters and hand sizes.,” *Hum Factors*, vol. 46, no. 2, pp. 244–251, 2004.
- [14] V. Mathiowetz, N. Kashman, G. Volland, K. Weber, M. Dowe, and S. Rogers, “Grip and pinch strength: normative data for adults.,” *Archives of physical medicine and rehabilitation*, vol. 66, no. 2, pp. 69–74, 1985.

---

# Glossary

## List of Acronyms

<b>3mE</b>	Mechanical, Maritime and Materials Engineering
<b>MAN</b>	Manual
<b>HSC</b>	Haptic Shared Control
<b>AHSC</b>	Adaptable Haptic Shared Control
<b>LoHA</b>	Level of Haptic Authority
<b>DOF</b>	Degree(s) of Freedom

