



Celebration as Revolution

Transformation of Waterworks to Public Bath

The Design Book

The Independent Group, Interiors Buildings Cities, 2020 Spring

Danyu Zeng

Content

Chapter 01

Celebration as Revolution
The Political Context of Copenhagen

Chapter 02

Waterworks as Public Bath
The Historical Context of Waterworks Plant

Chapter 03

The Collective Bath
Reappropriation of Boilerhouse

Chapter 04

The Experiential Bath
Reappropriation of Pumphouse



Chapter 01

Celebration as Revolution

from Workers' Movement to Copenhagen's Largest Street Festival

The workers fight lasted until 2008, when Danish government was forced to let the movement take possession of a new building. The street life and night culture rooted in such a movement.

“Distortion — A Celebration of Copenhagen Night-life” was born in 1998 for a one-night party in Tivoli, Copenhagen.

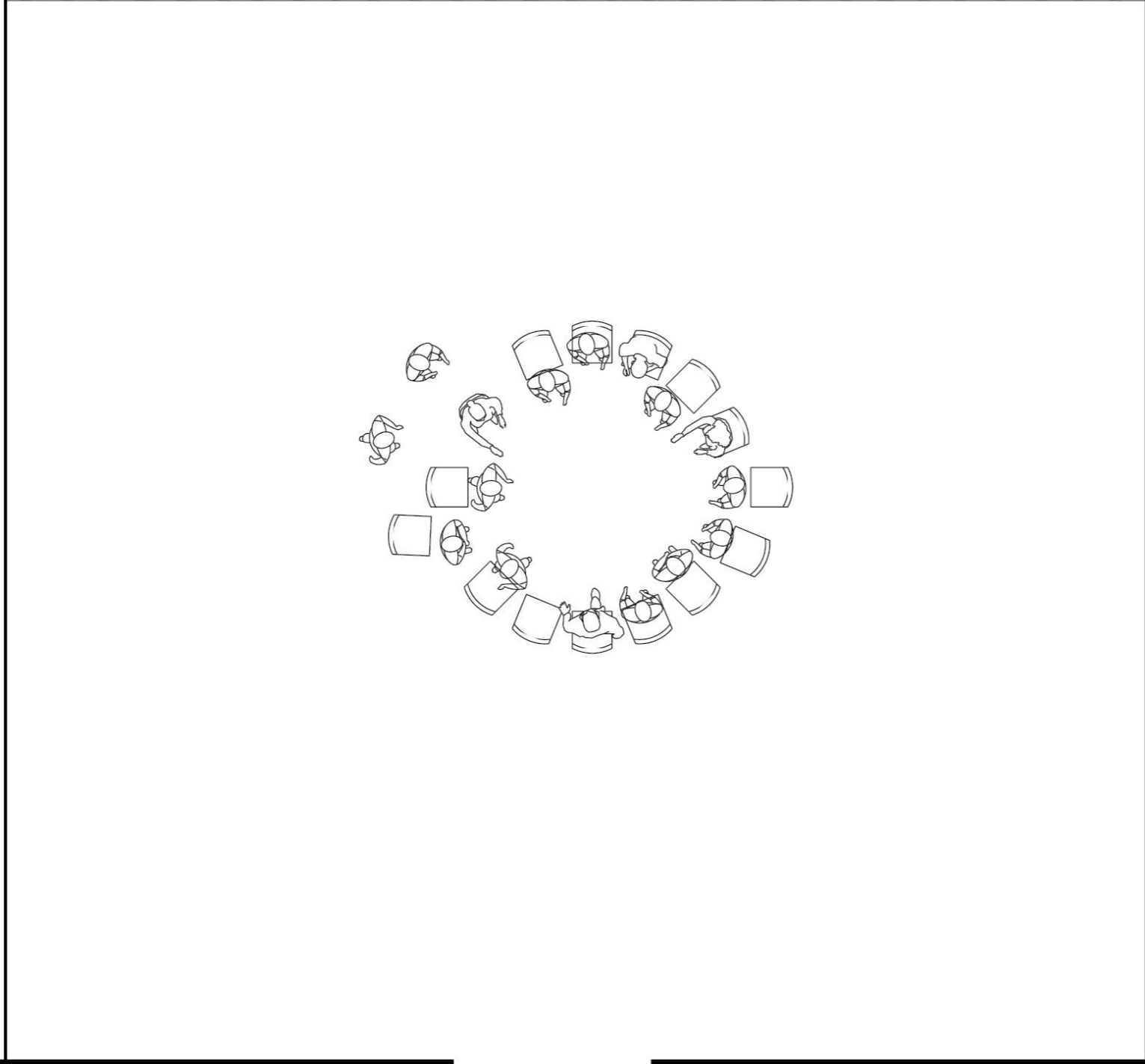
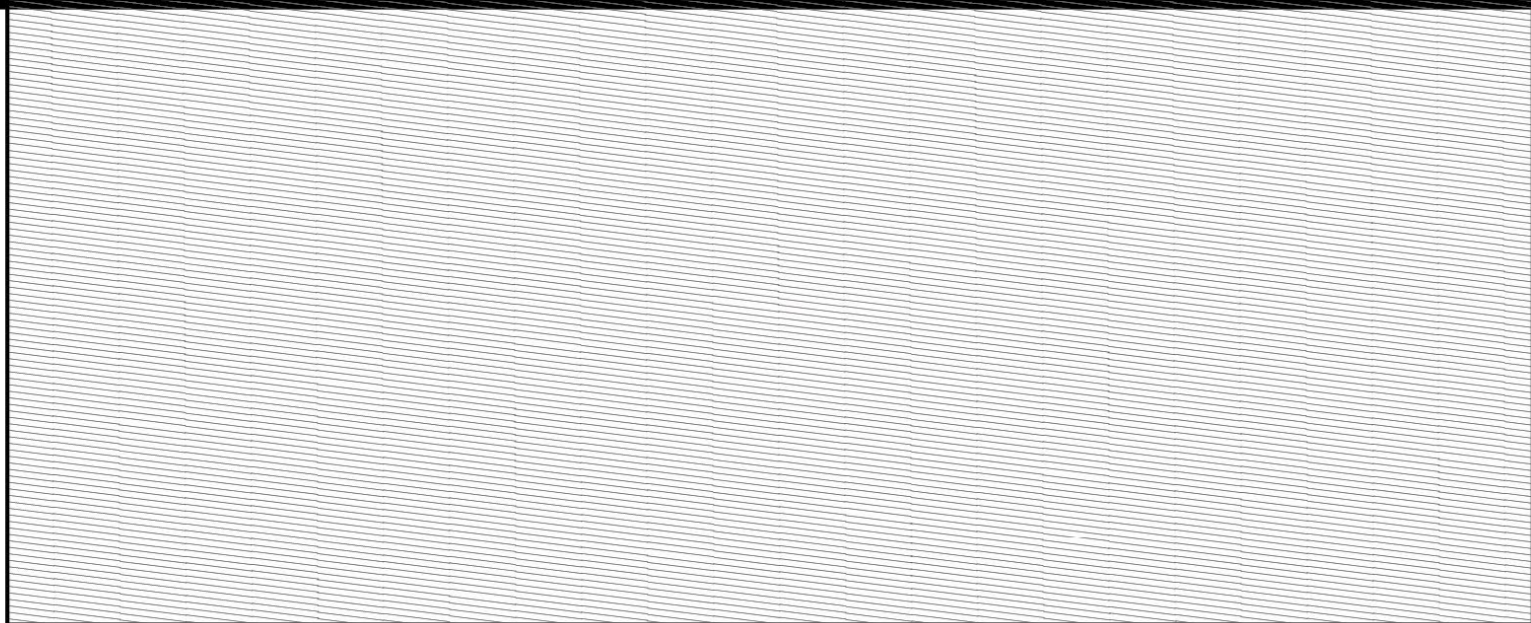

Meeting in Youth House
for the Battle of Ryegade



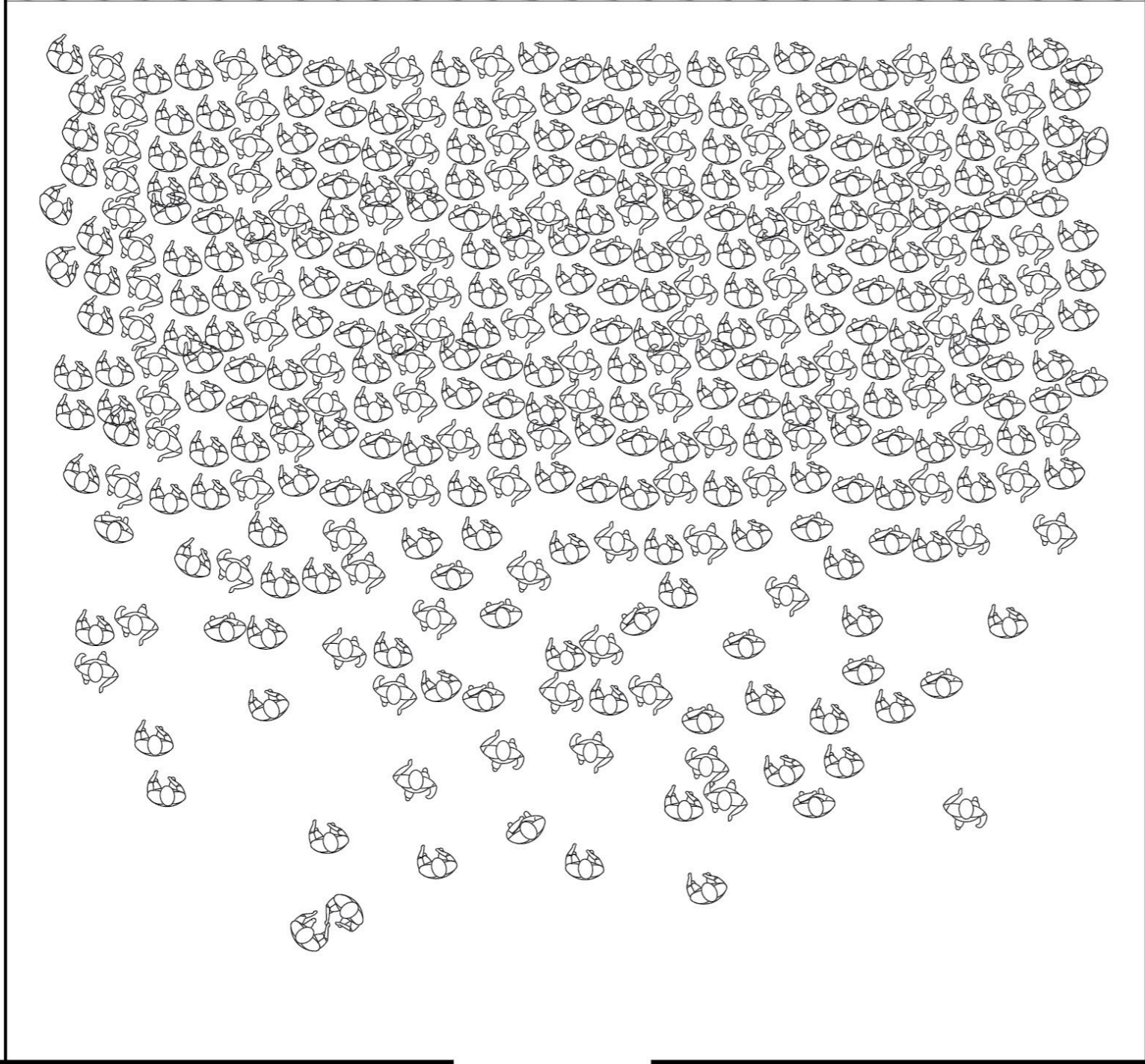
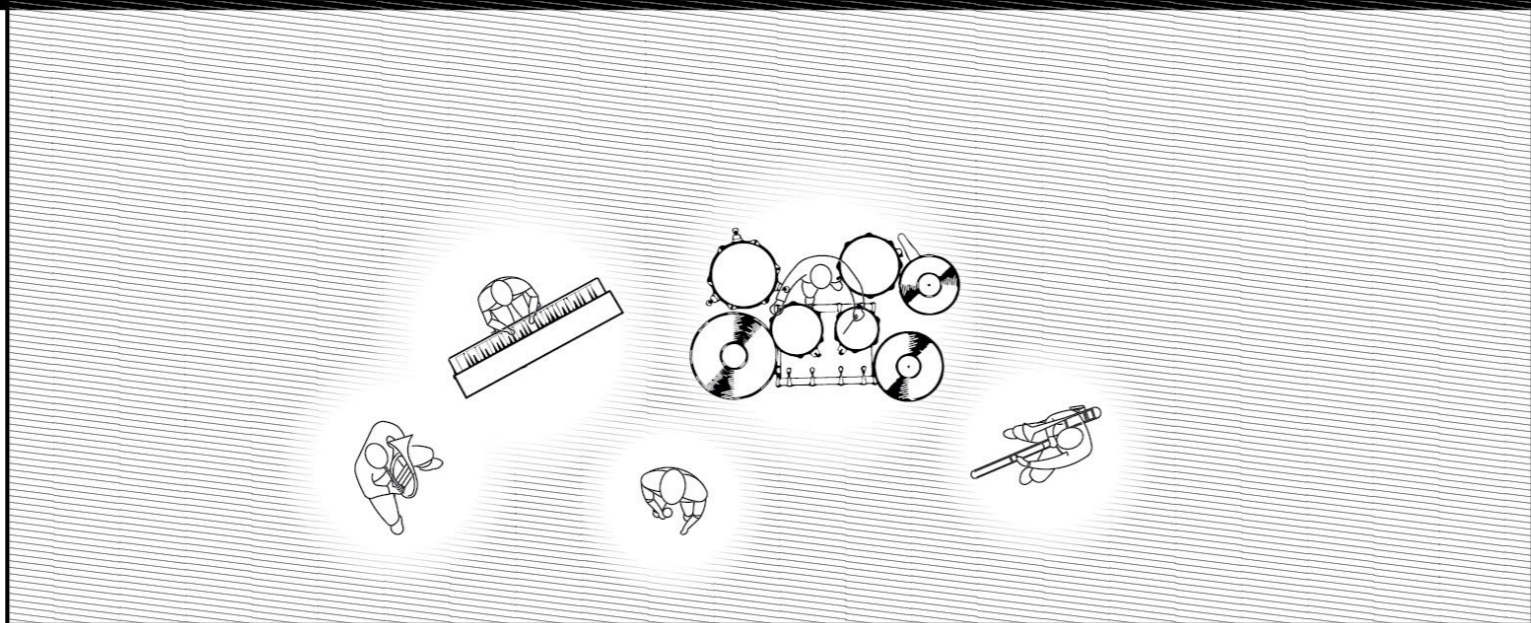

Celebration for Friday Victory

“Too good to be true! More than a thousand people scream in victory. Everyone rushes to the door. A party has started. This is Friday. We hold the house until the cops come back to evict us Monday morning. In just forty-eight hours, the house is transformed into a place with electricity, a concert hall, workshops, and info points. People work on reinforcing the barricades constantly, build chairs and tables in the workshop, and bring in furniture from waste dumps and food from the local supermarket’s dumpster. We held it for only forty-eight hours, but in that short period of time we witnessed the amazing results of what can happen when people work together..”



The Celebration in the Youth House
Origin of Urban Celebration



Pumphouse in the Site
Copenhagen's Waterworks Outdated



Pumphouse in the Site

Renovated as Music Venue Featuring Urban Subculture

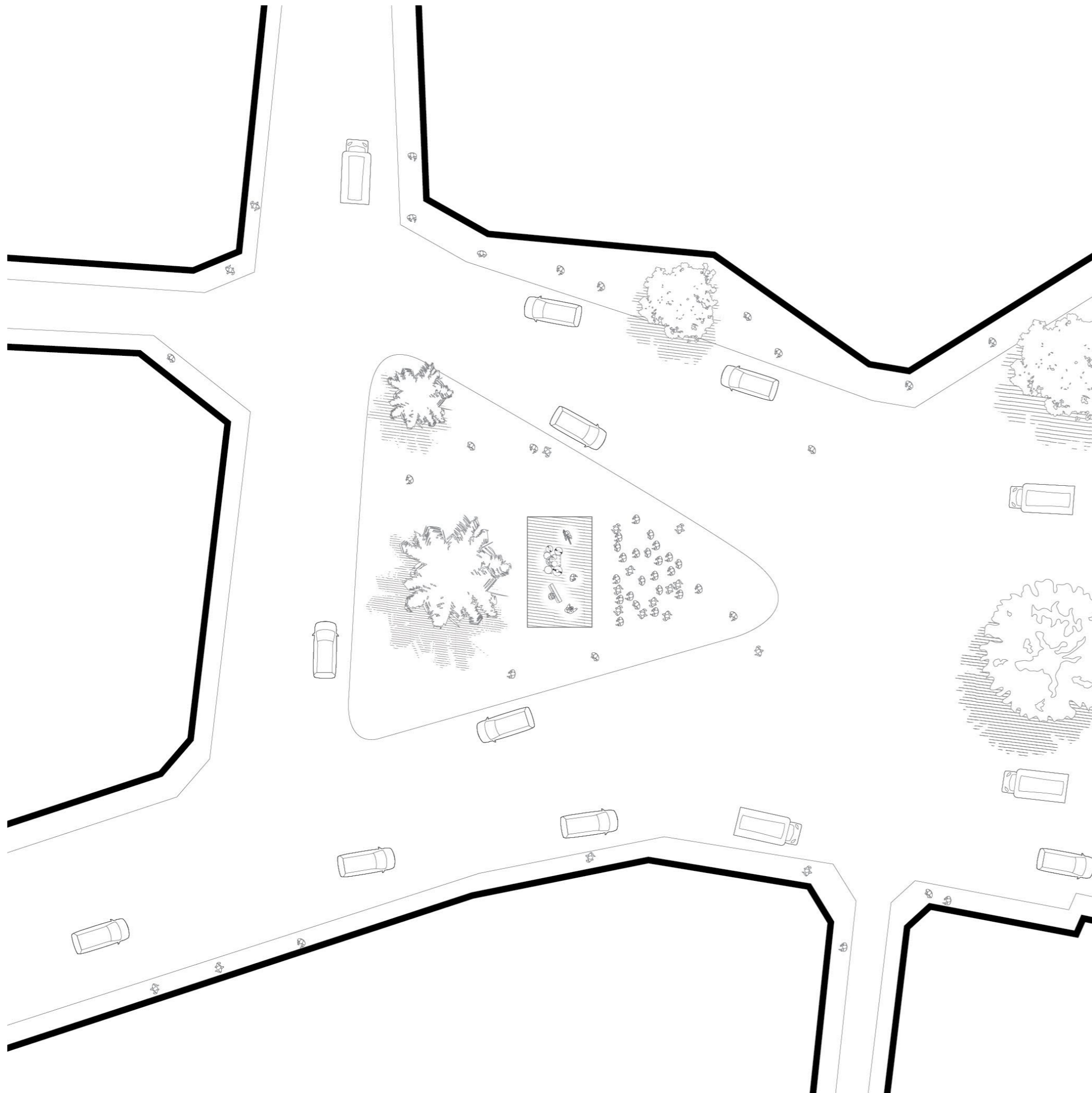

Founding of Distortion

The workers fight lasted until 2008, when Danish government was forced to let the movement take possession of a new building. The street life and night culture rooted in such a movement.

“Distortion — A Celebration of Copenhagen Night-life” was born in 1998 for a one-night party in Tivoli, Copenhagen.

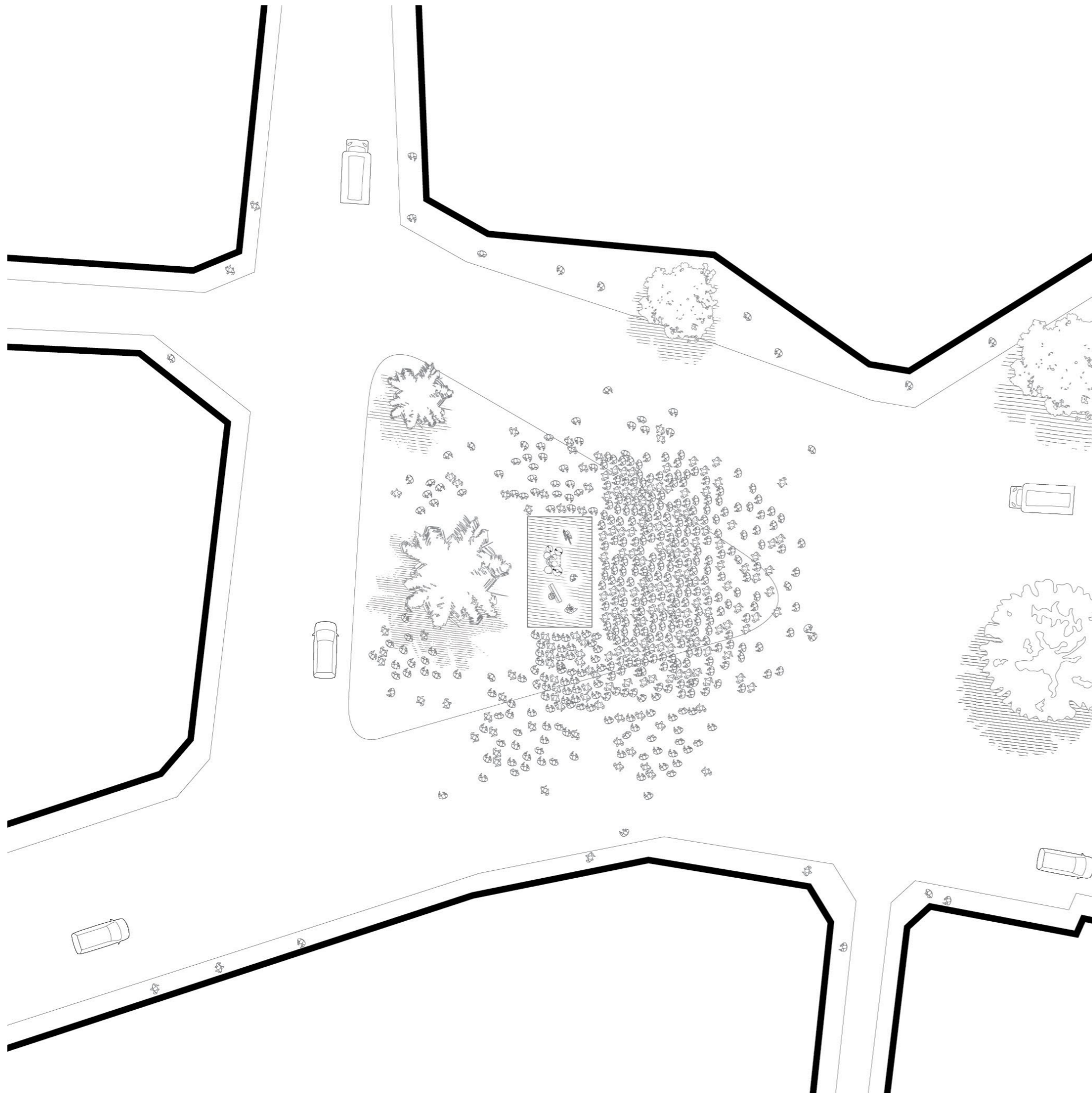

The Idea of Ultra-Mobility

The idea of ultra-mobility brought the party to the street. It was small, chaotic, and not fully-legal activity. But after gathering 2.000 guests at a single street party, Distortion saw its victory and won the legitimation from the Copenhagen City Council and becomes Copenhagen's largest festival,

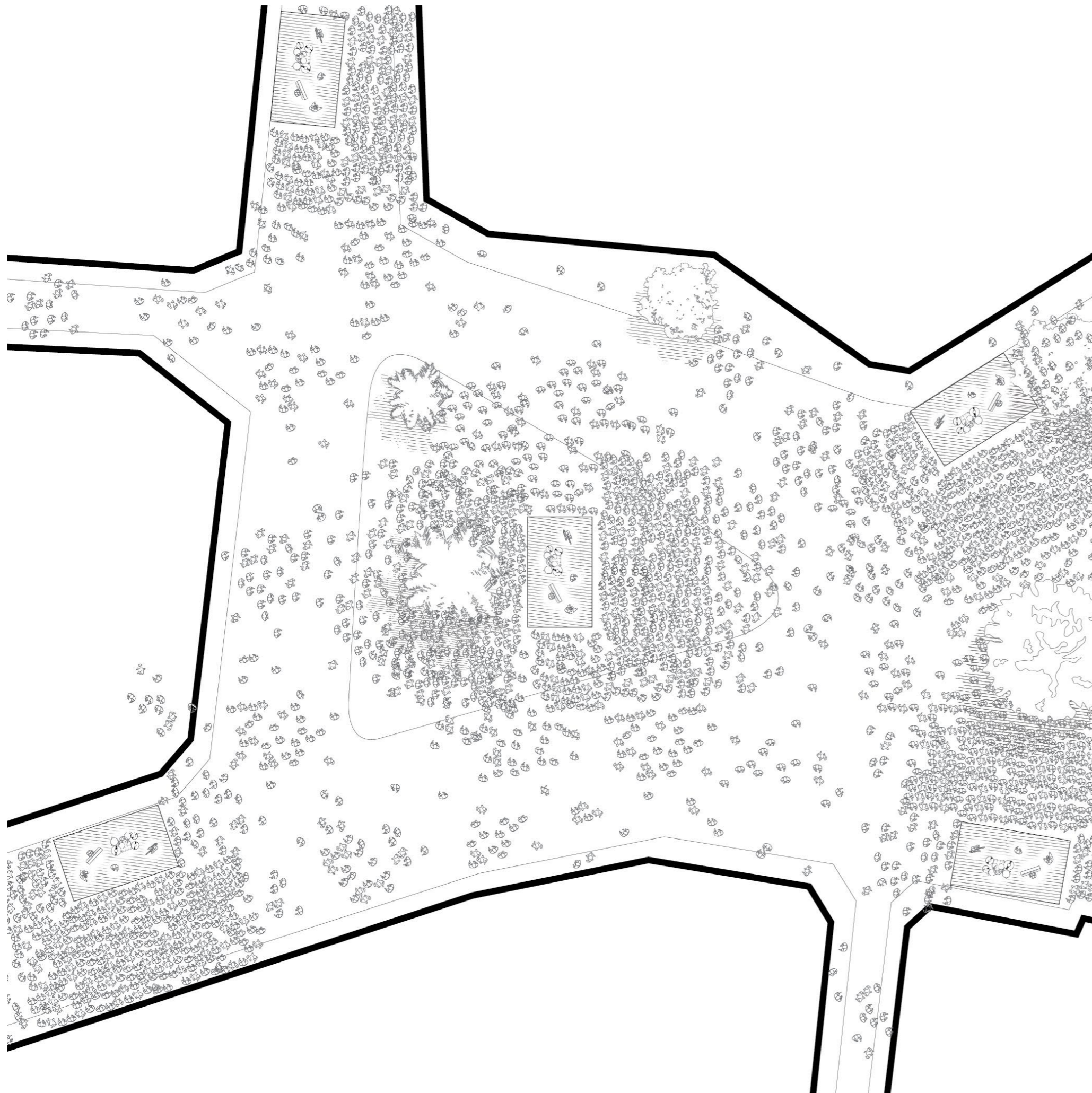

Legitimation

The idea of ultra-mobility brought the party to the street. It was small, chaotic, and not fully-legal activity. But after gathering 2.000 guests at a single street party, Distortion saw its victory and won the legitimation from the Copenhagen City Council and becomes Copenhagen's largest festival,



The Distortion Festival in Street
Celebration as Revolution



Site



Pumpehuset Summer Concert



Map of Subculture Clusters
The Marginalized Area



Map of Distortion
Marching Towards Center



Location of the Site

New Possibility of Linking Street Events



Map of Copenhagen 1860

The Fortress Ring
The Urban Fabric of Copenhagen

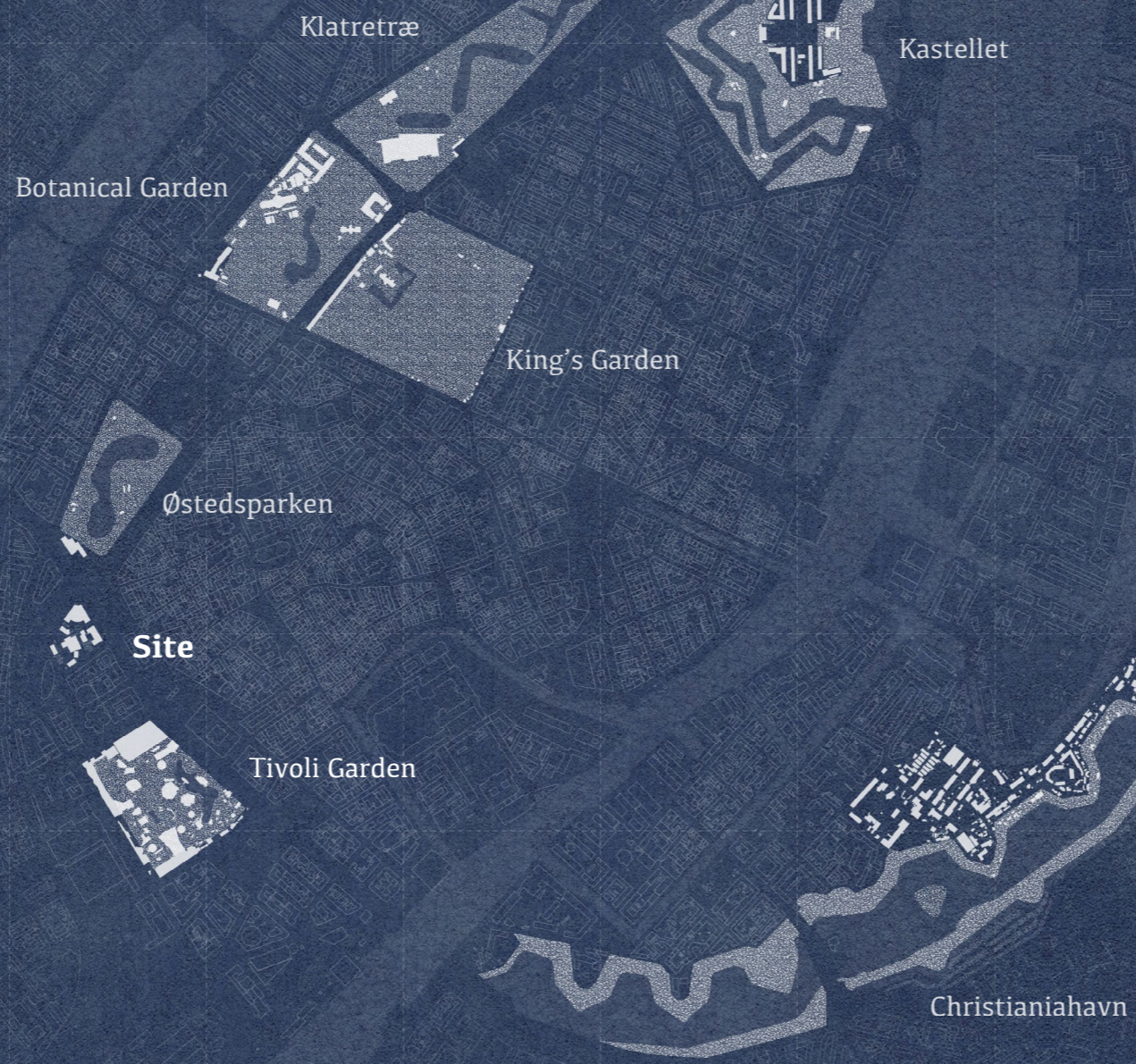

Map of Copenhagen 2020

The Fortress Ring

The Public Gardens

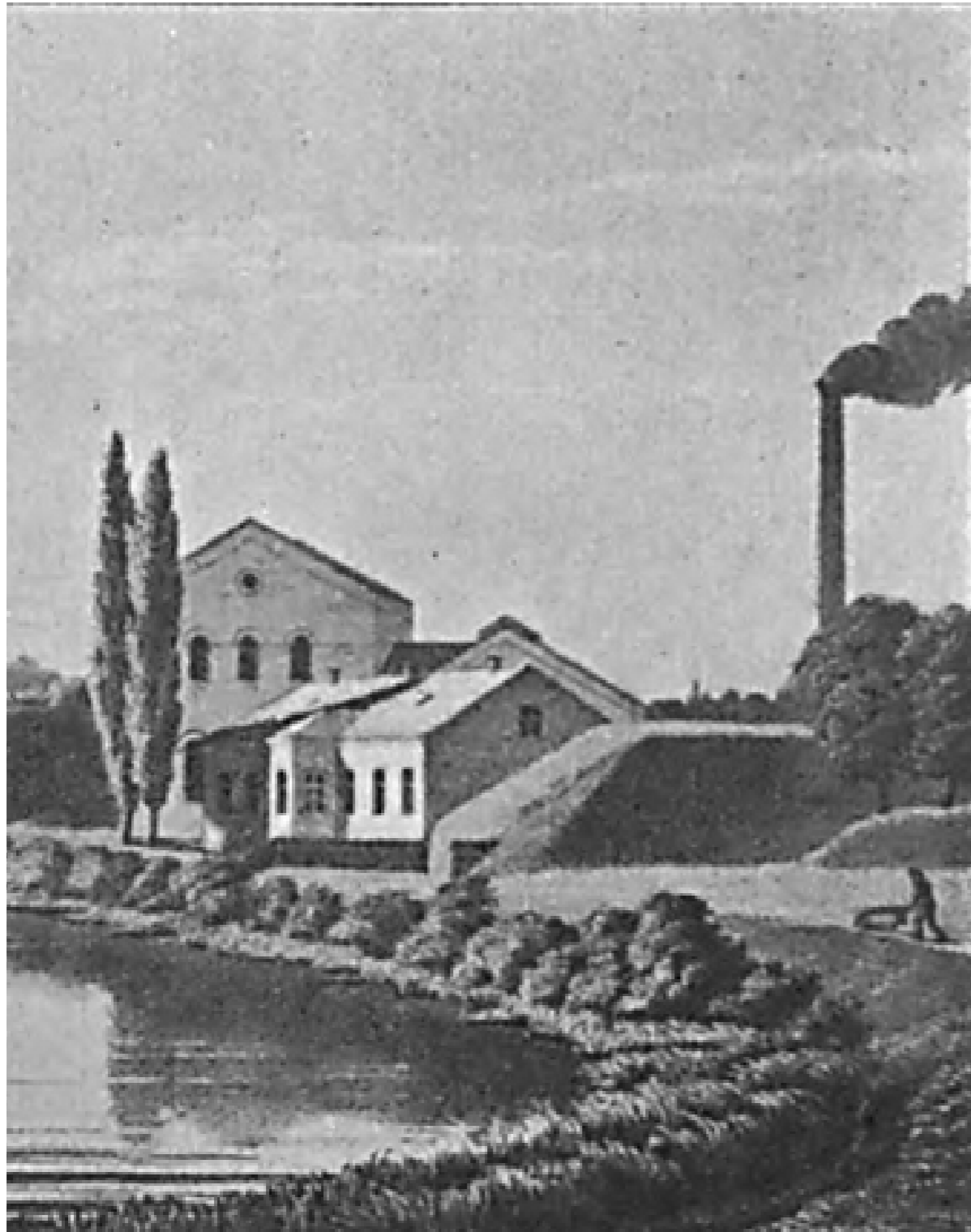

the Waterworks Plant (1859)

View from Fortress Ring

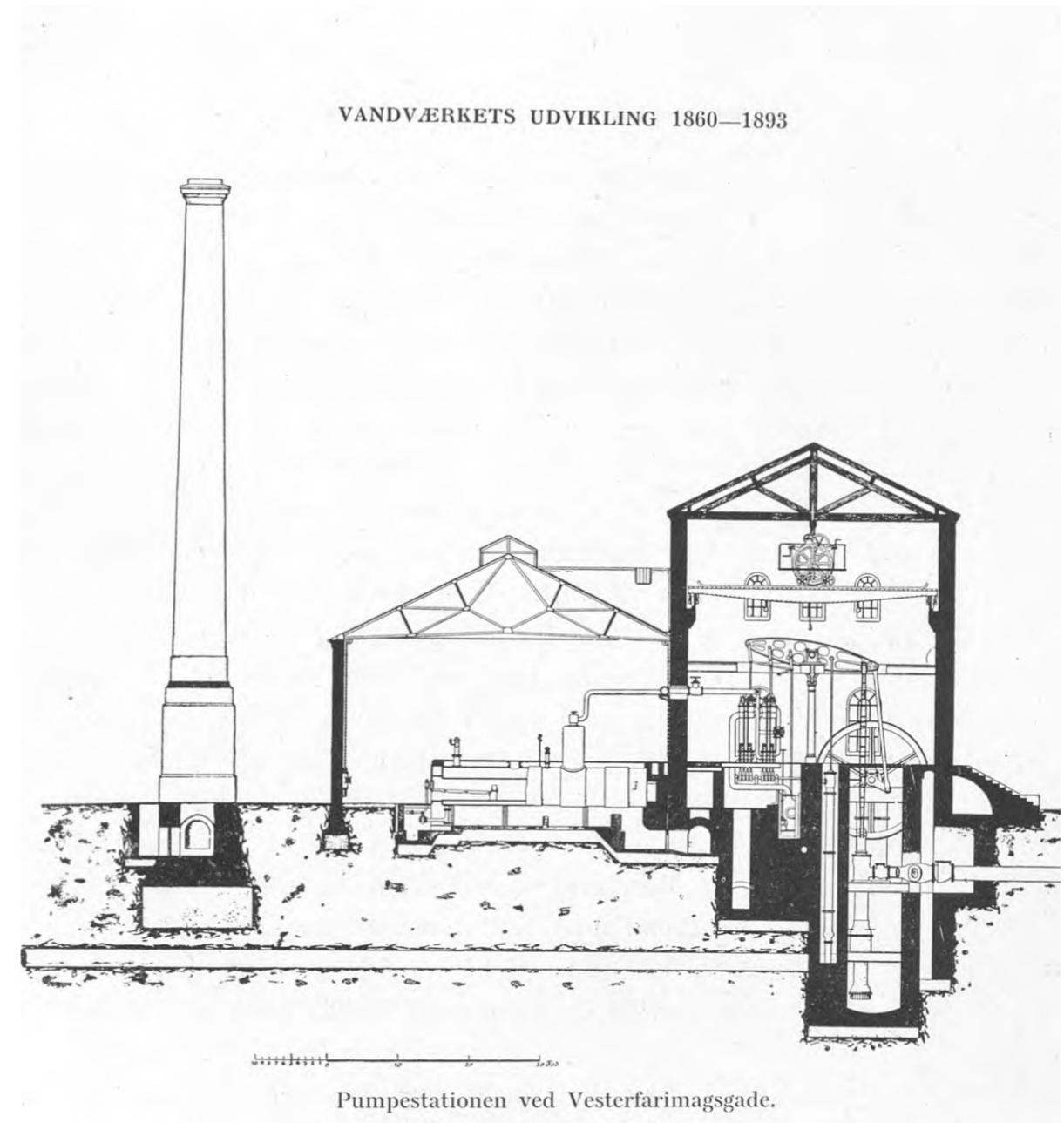

Section of Machine House

Chimney/Boiler House/Pumphouse



Chapter 02

Waterworks as Bathhouse

Integration of the Cleansing Ritual with Festive Moments

Transformation of waterworks as Bathhouse is an idea of bringing bathing experience to the urban celebration. A combination of cleansing and celebration refers to the characteristics of this industrial monument with water and machine. It addresses the current demand of the city for more bathing facilities.

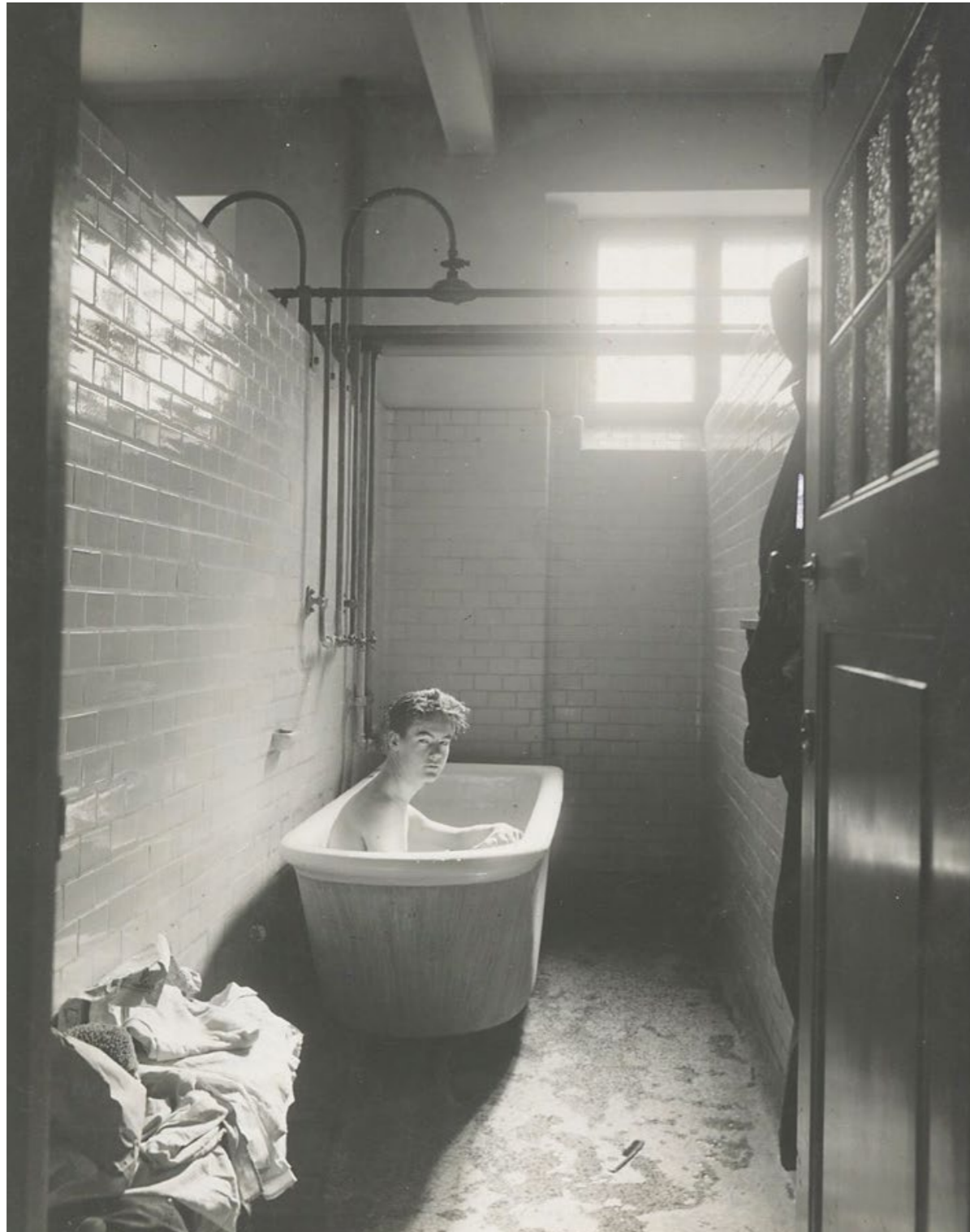

Bathhouse in Copenhagen

The Rising Concious of Hydrene

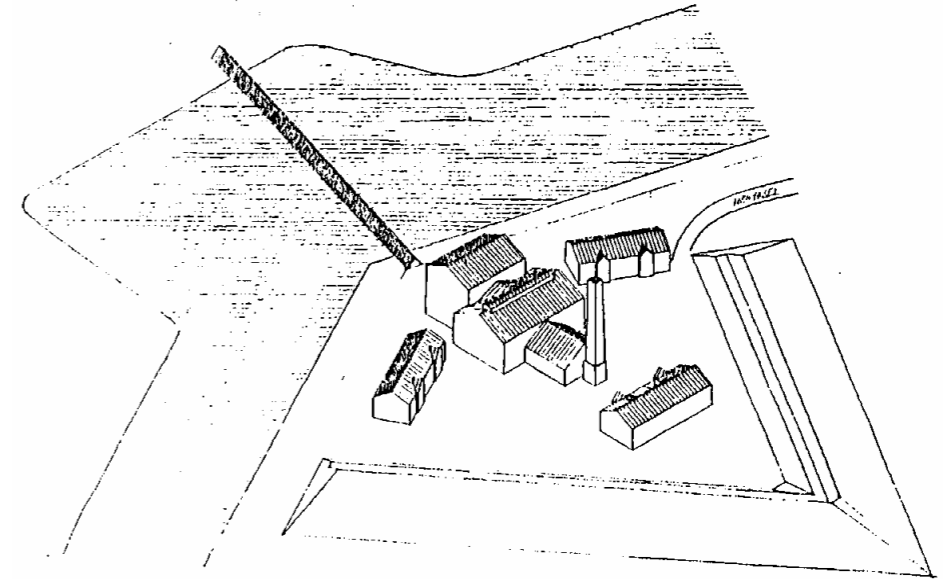

1859

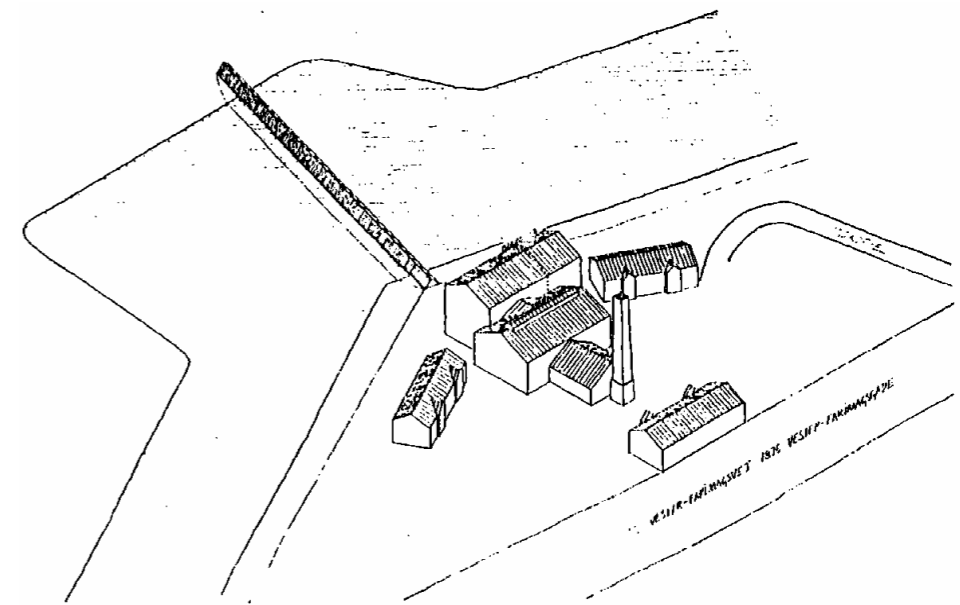

1880

Sanitation Movement

Copenhagen's first waterworks built in 1859

First Expansion of Pumphouse in 1880



Bathing Facilities in Copenhagen

Connection Established with Water

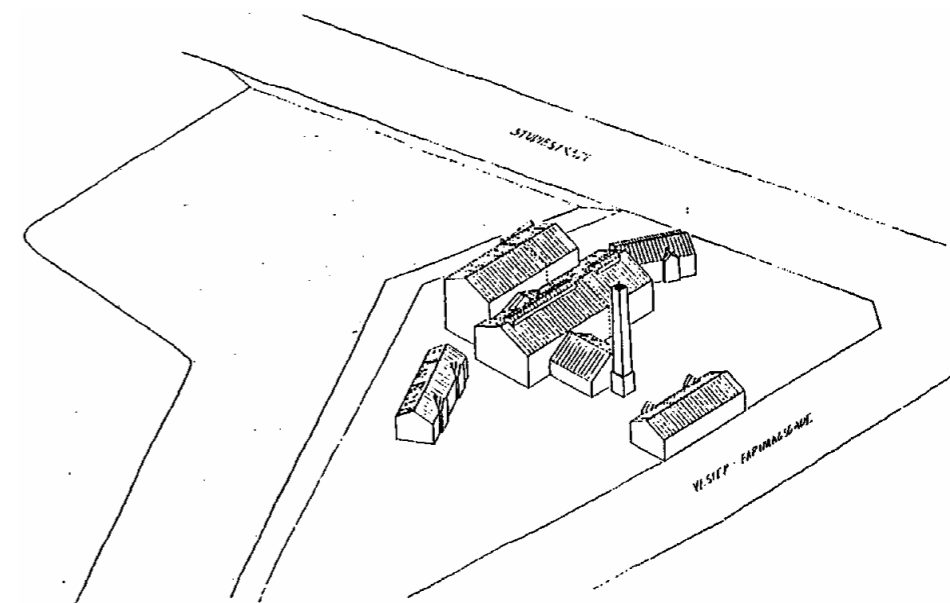

1883

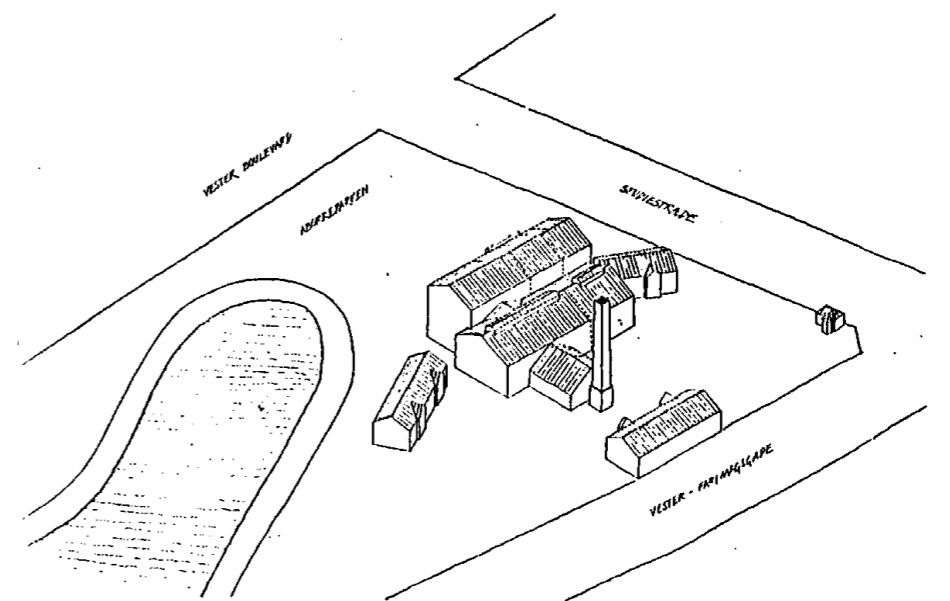

1890

Increasing Demand of Clean Water

First Expansion of Boiler House in 1883

Second Expansion in 1890



A Ban on Harbour Bath (Pollution)

Lack of Bathing Facilities between 1950-2000

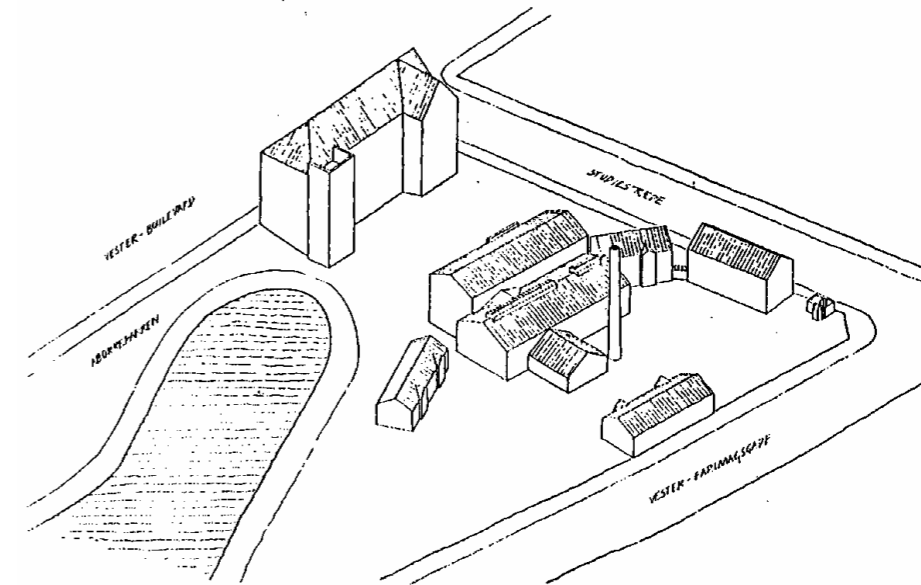

1914

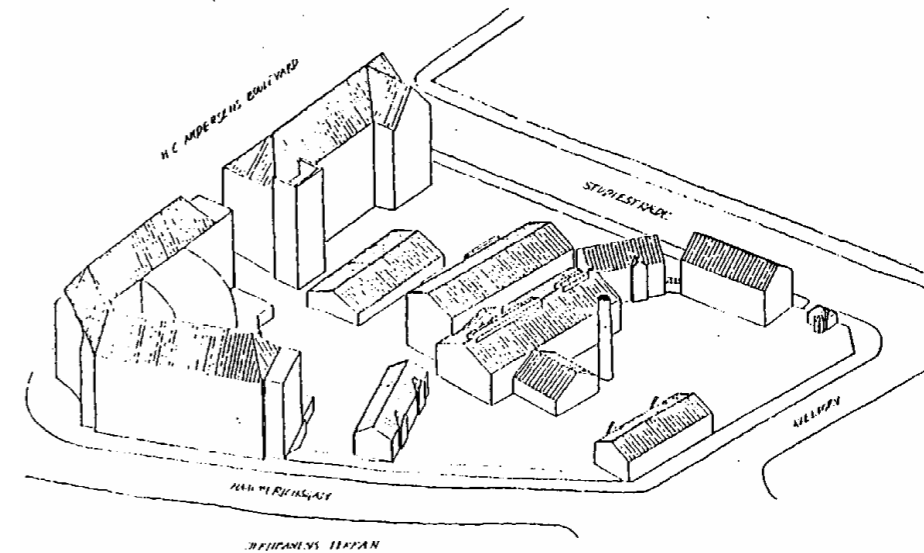

1970

The Modernization of Copenhagen

Offices Building added in 1914

Water Disappeared in 1970



Bathhouse Reappropriate as Social Meeting Place

Individual Cells Expanded to Gathering Rooms



Bathhouse Reappropriate for Cultural Events

A Possibility of Urban Celebration

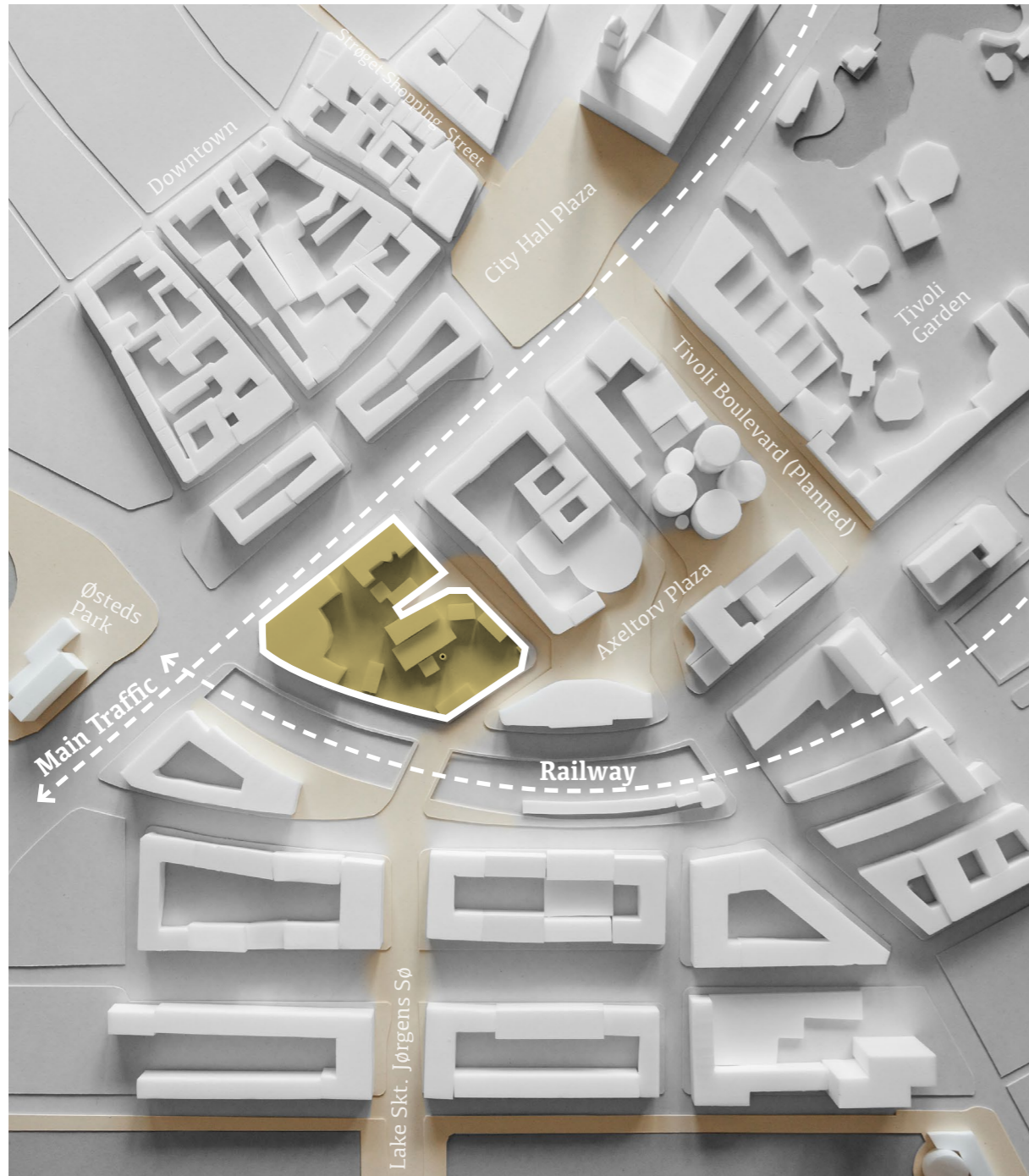

The Urban Context

1:2000 Site Model



Current Public Accessibility



Current Program: Kindergarten, not open to Public



Current Program: Pumpehuset Music Venue and Garden

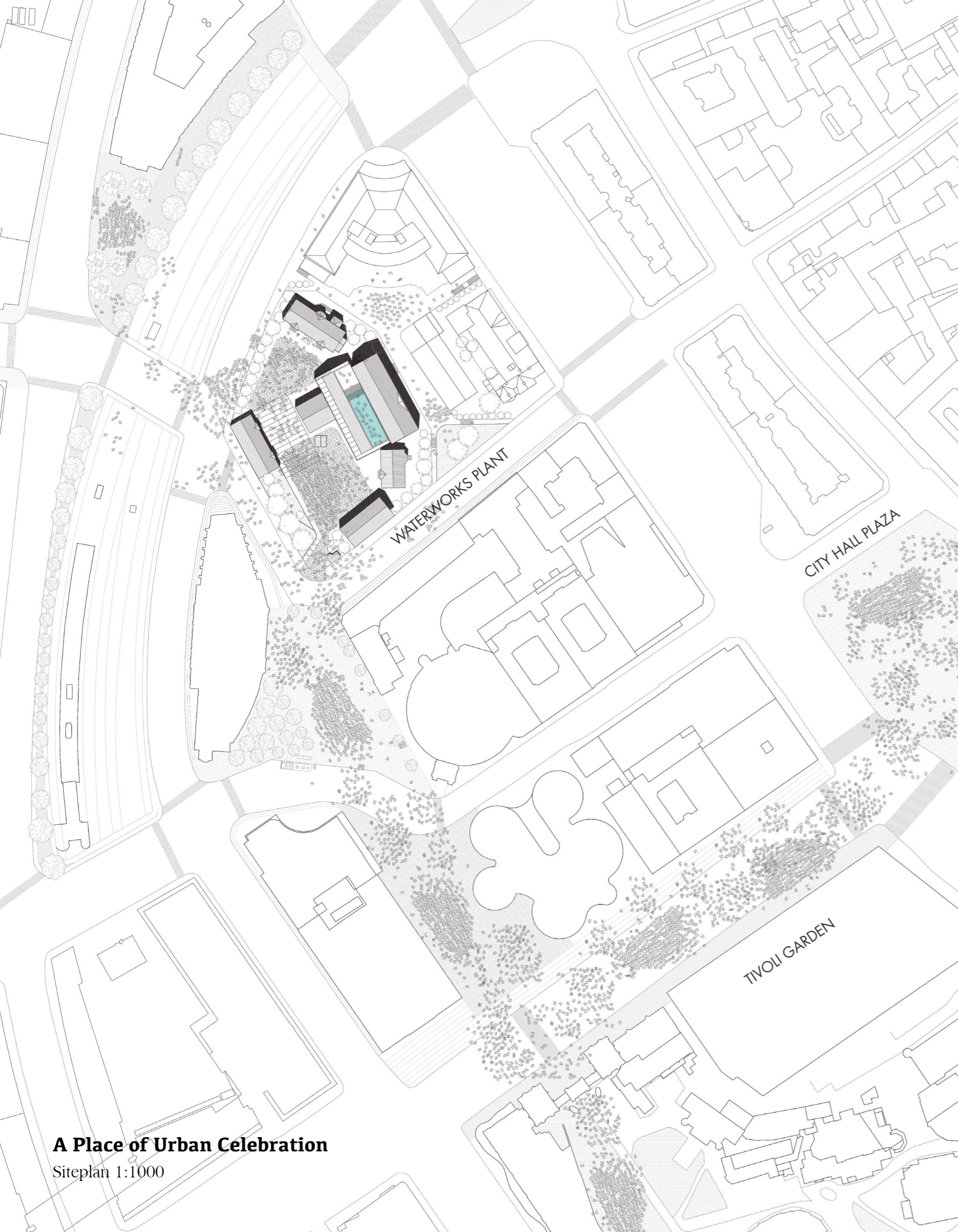

A Place of Urban Celebration

The site is seen as an urban link of the Distortion street events. The popularity of the sub-culture musical activities has proved its power of gathering massive participation. In those celebrations, in the cultural event, everyone becomes pure and transparent. That is when the transcultural moments happen.

A Place of Urban Celebration

Siteplan 1:1000

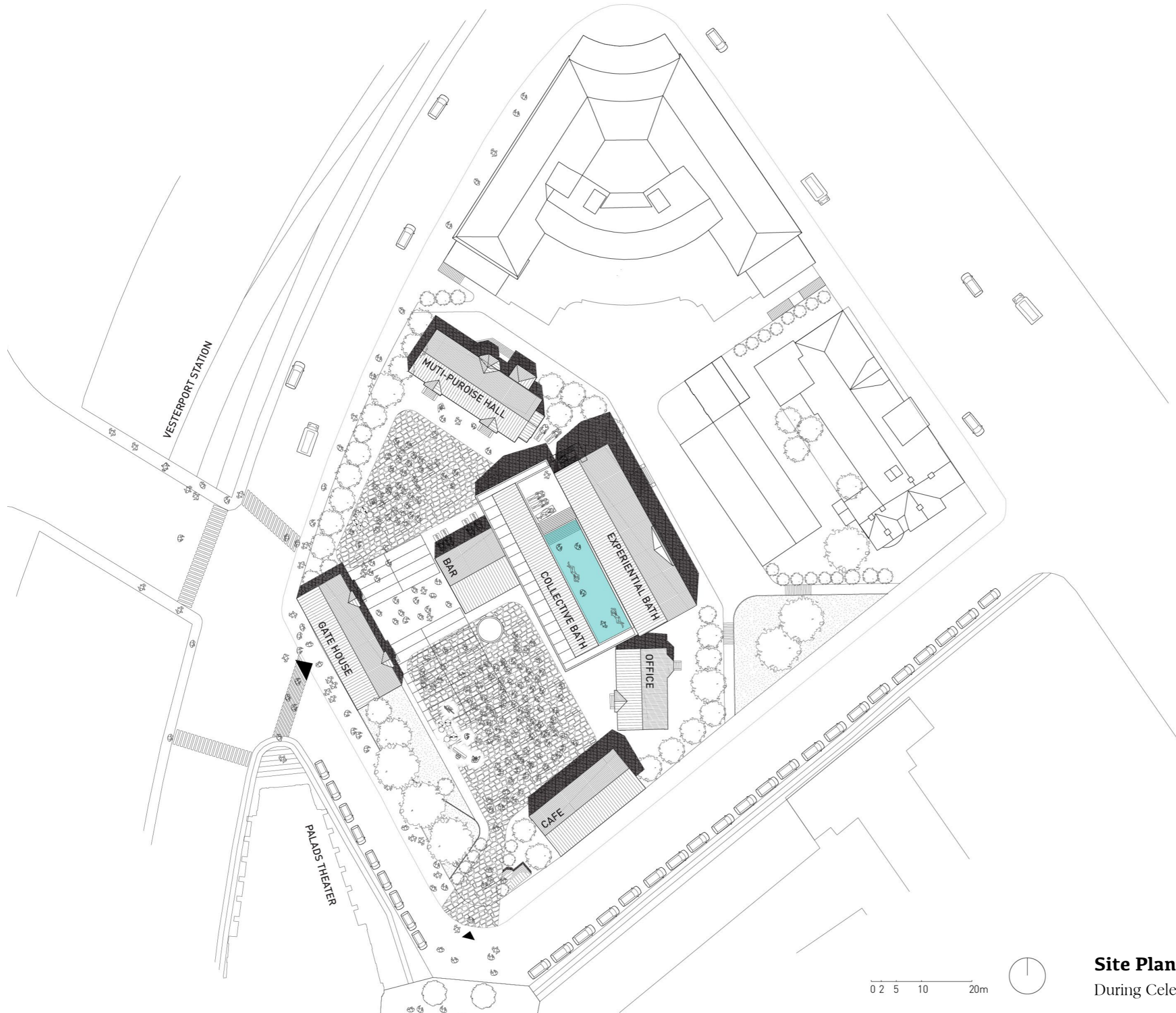

Building Guide

- 1 Bar**
Coal House (1859)
Garage(1954)
Kitchen of Kindergarten (2013)
- 2 Collective Bath**
Boiler House (1859)
Boiler House Extension(1885 -1893)
Garage & Cafe (1954)
Kindergarten (2013)
- 3 Vitality Baths**
Pumpehuset (1859)
Pumpehuset Extension(1885 -1893)
Music Venue (1989)
- 4 Gate House**
Residence of Lighthouse Keeper (1859)
Residence of Engineer (1880)
Kindergarten (2013)
- 5 Multi-purpose Hall**
Residence of Engineers (1859)
Director's Residence (1880)
Kindergarten (2013)
- 6 Cafe**
Office (1900)
- 7 Admin**
Office (1900)

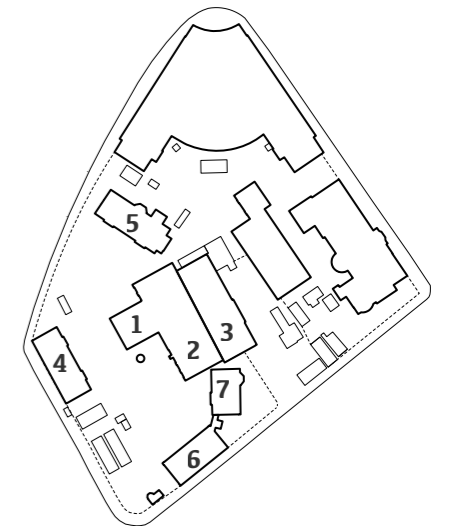

0 2 5 10 20m



Site Plan 1:500
During Celebration



A Place of Pleasure Relates to Water

A Fun Bathing Place

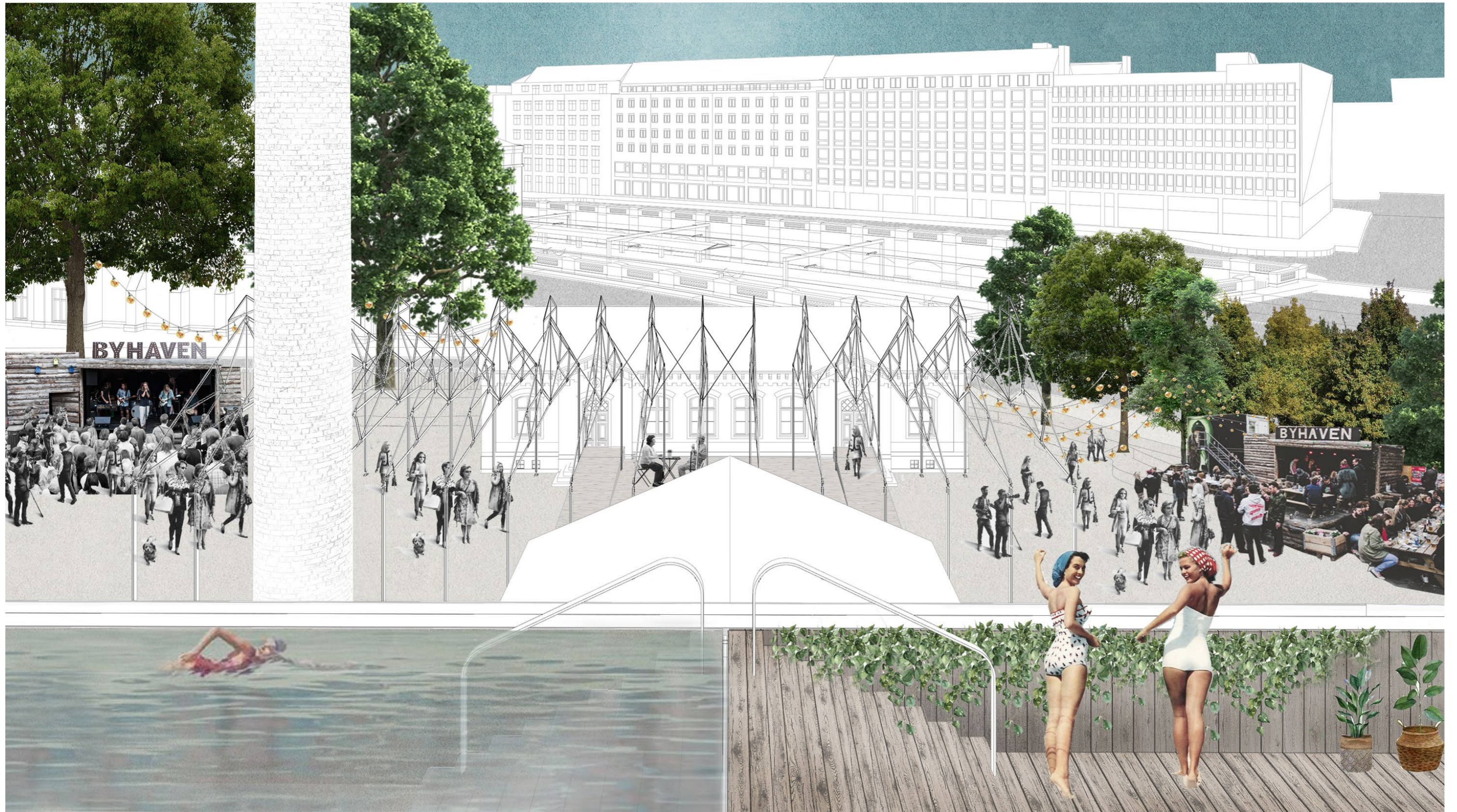

Bathers Participating Urban Celebration

View from the Roof



Location of Outdoor Pool

1:250 Section Model Study



Reappropriation of a New Subculture Center

1859

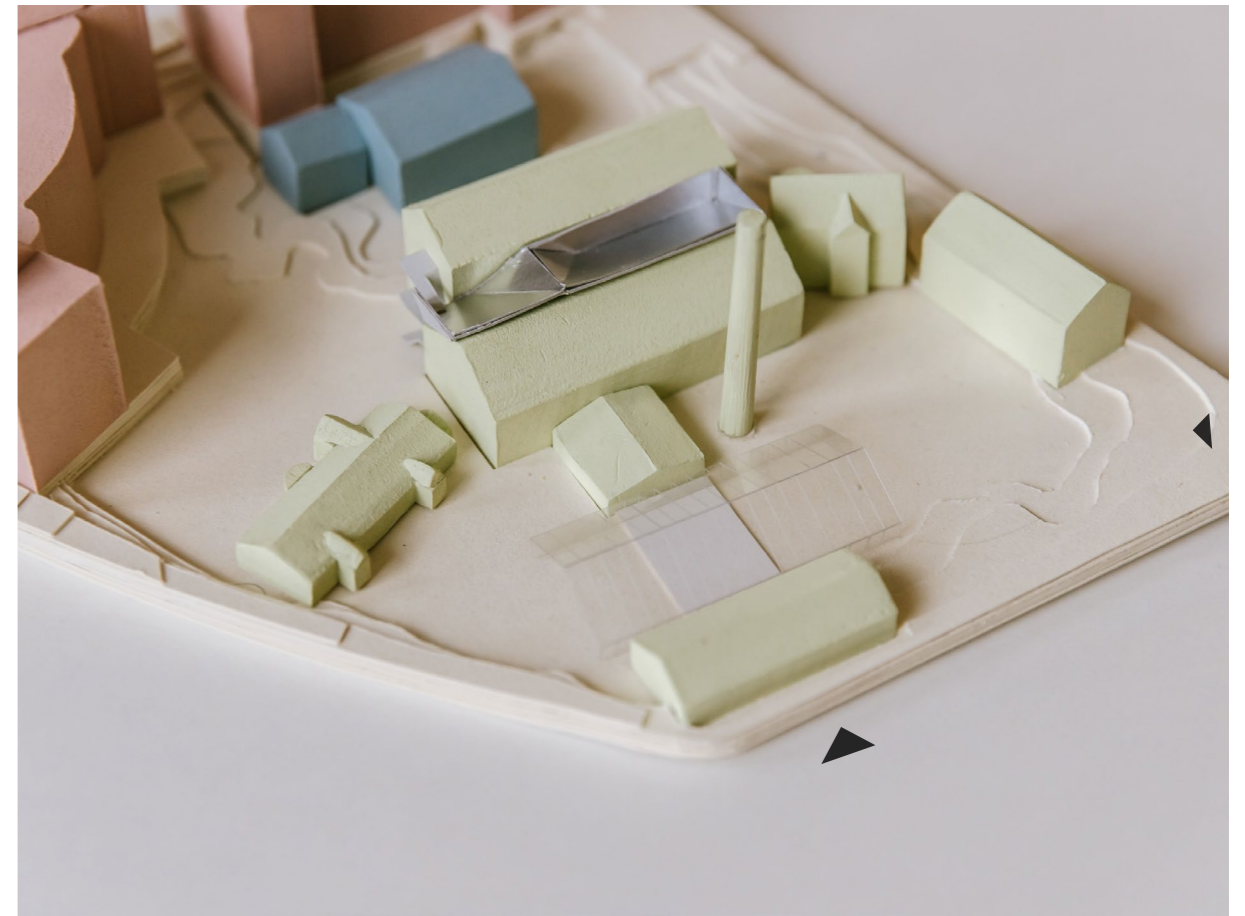

Volumetric Study 1:500 Site Model

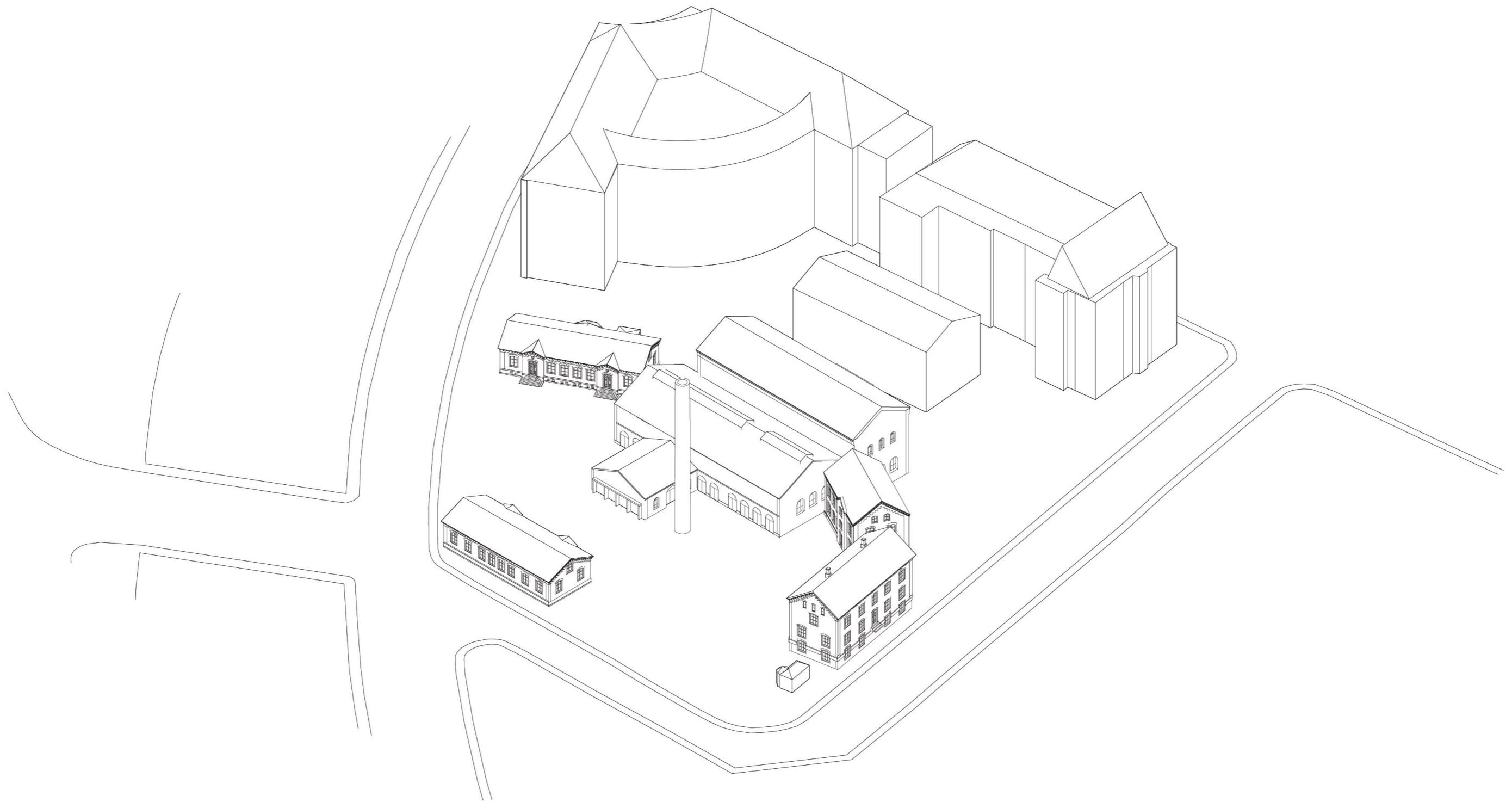

Current Massing
The Volumetric Approach

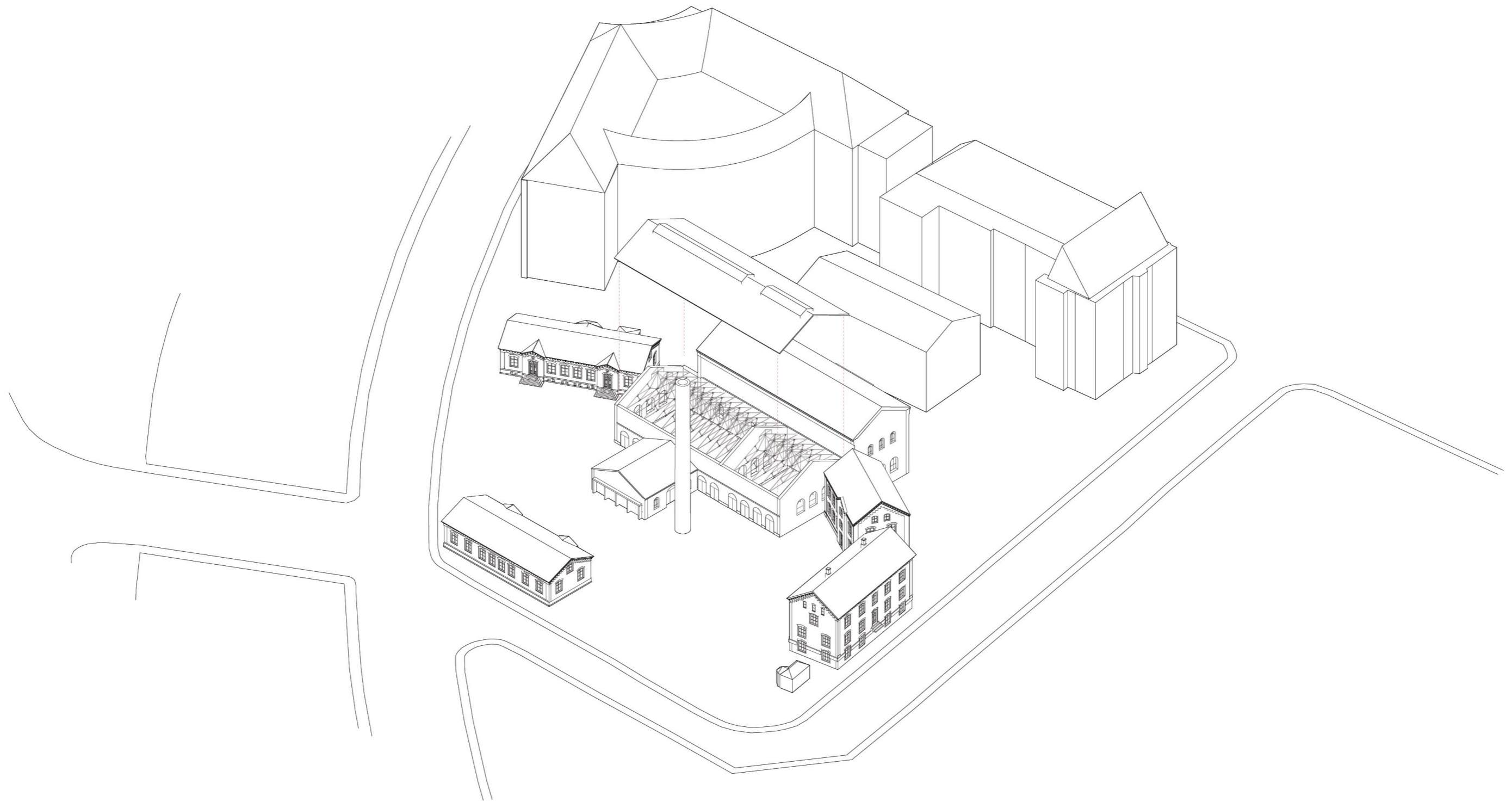

Remove the Existing Roof
The Volumetric Approach

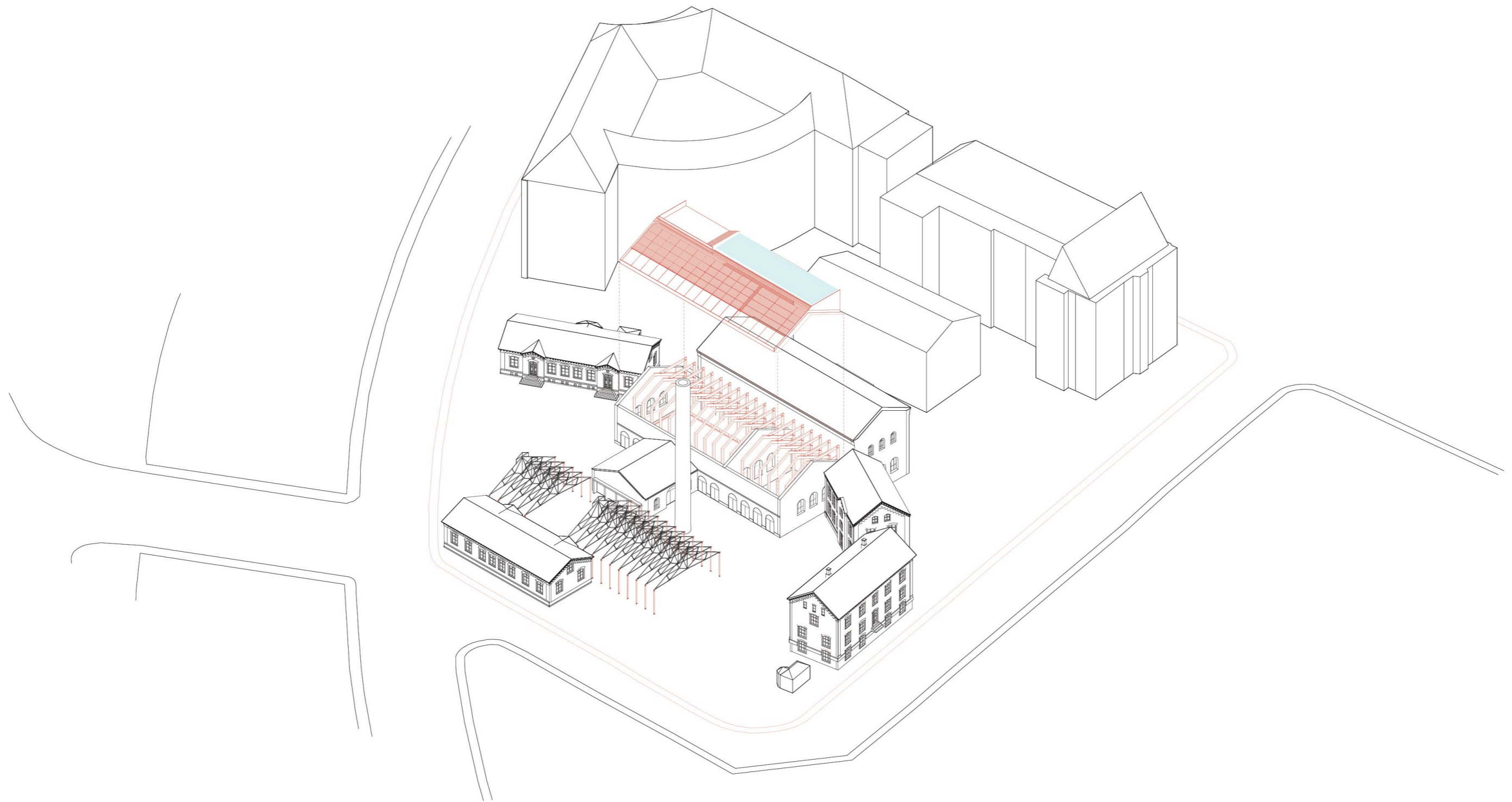

Old Truss Placed on Site & New Independent Structure Inserted

The Volumetric Approach

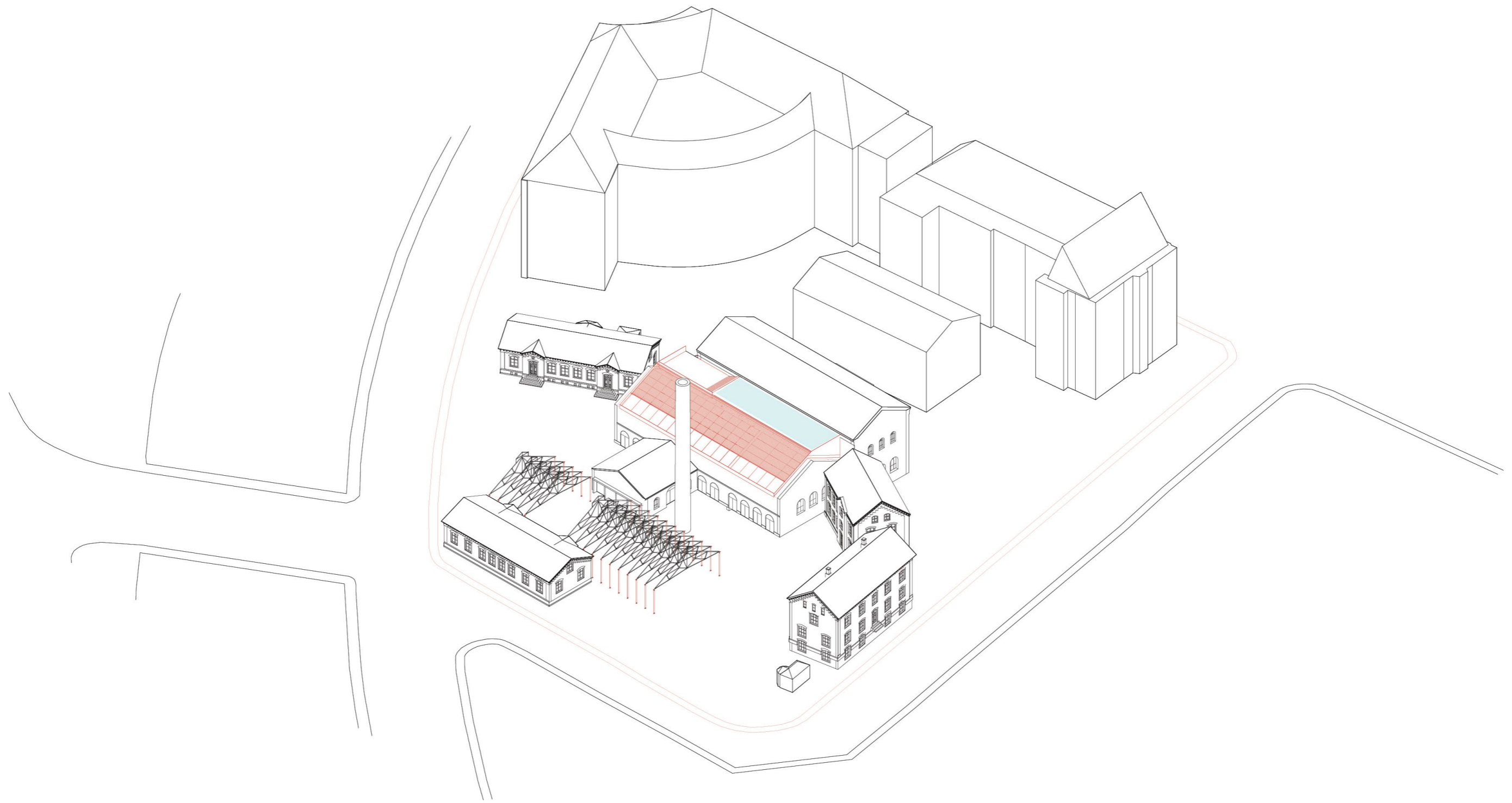

New Roof with Bath on Top
The Volumetric Approach

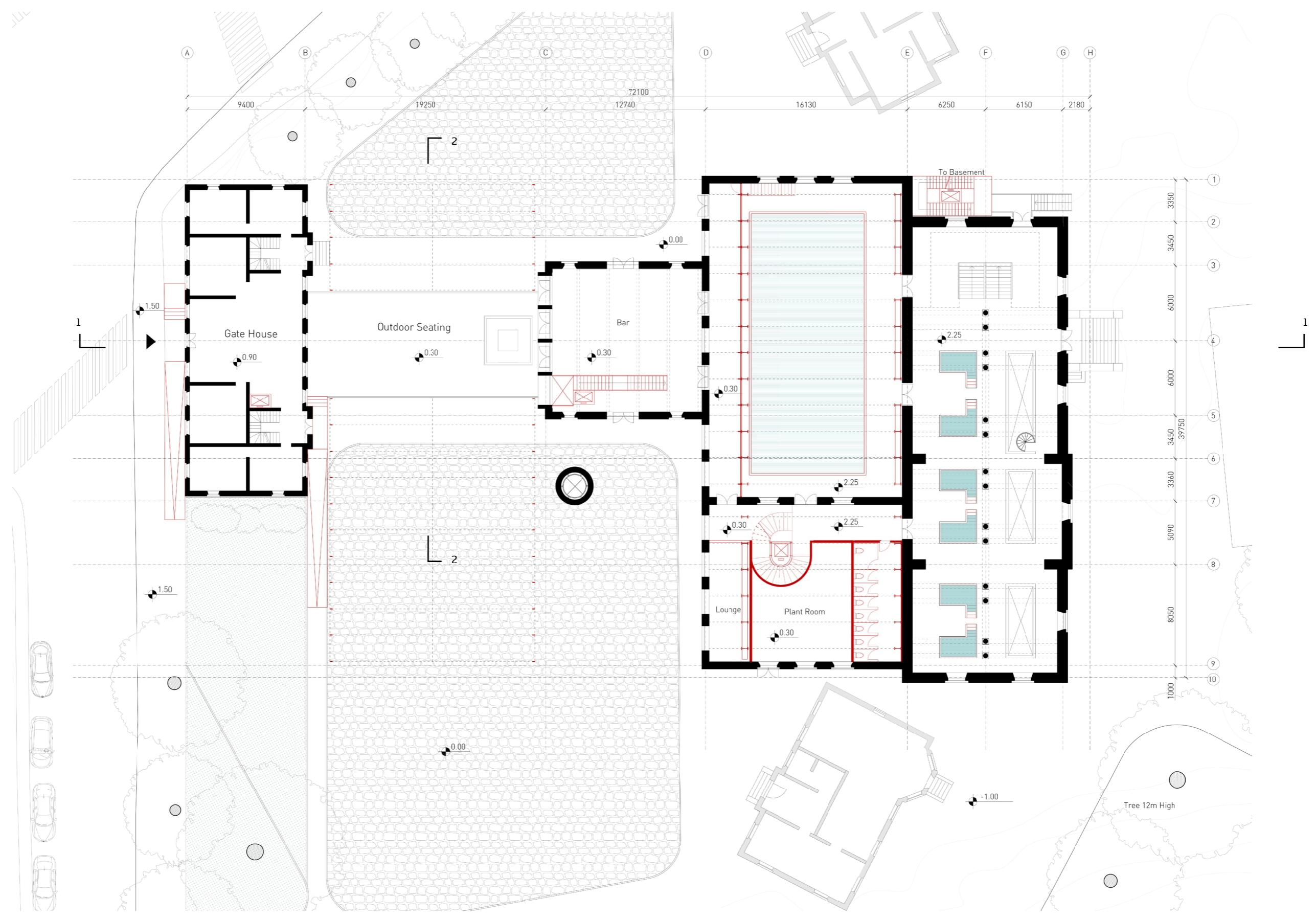

Ground Floor Plan

1:300

0 2m 5m 10m 20m

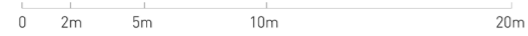
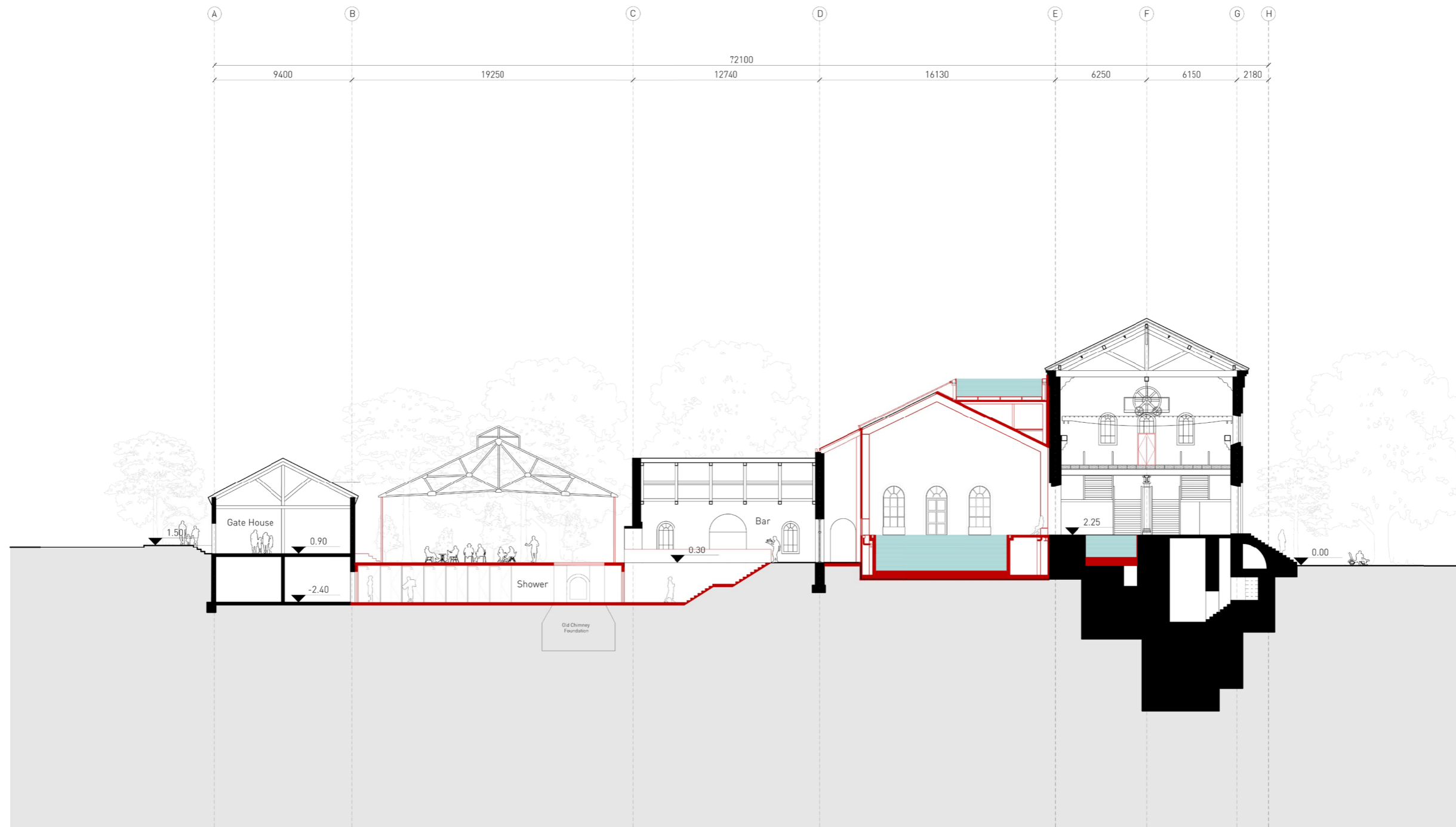

Site Section 1-1
1:300

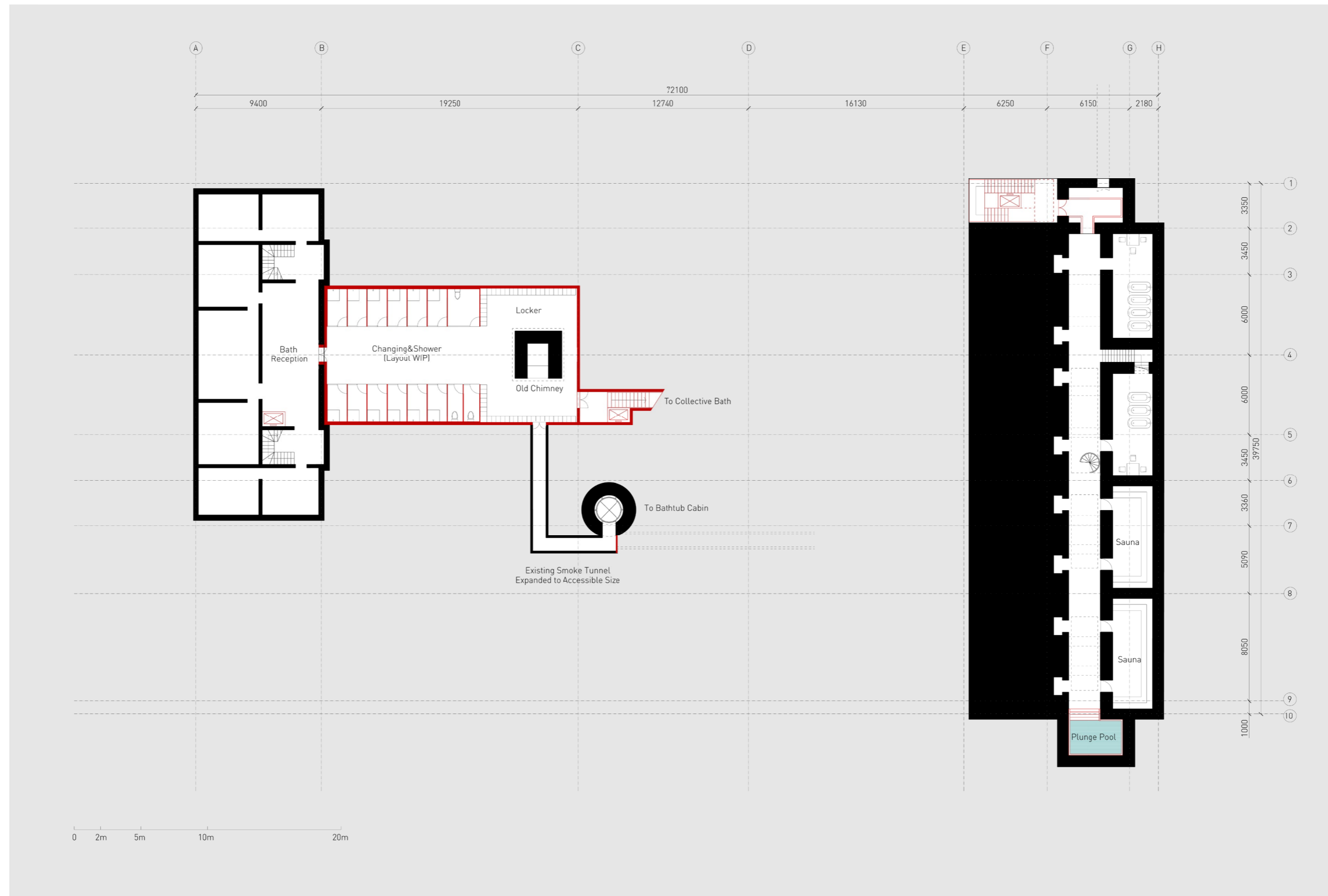

Basement Plan

1:300

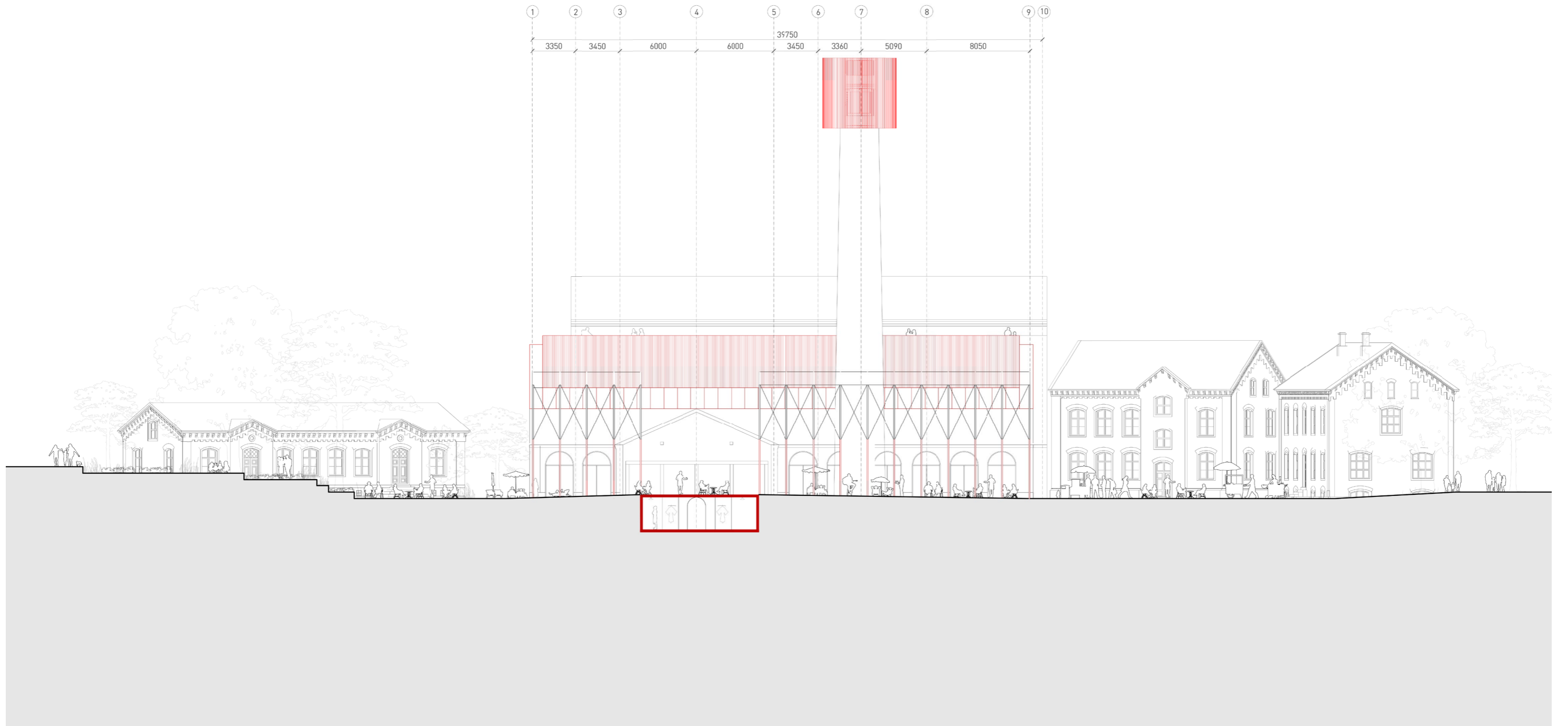

0 2m 5m 10m 20m

Site Section 2-2

1:300

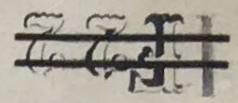

Handwritten notes at the top left, including '1884' and 'W. ...'

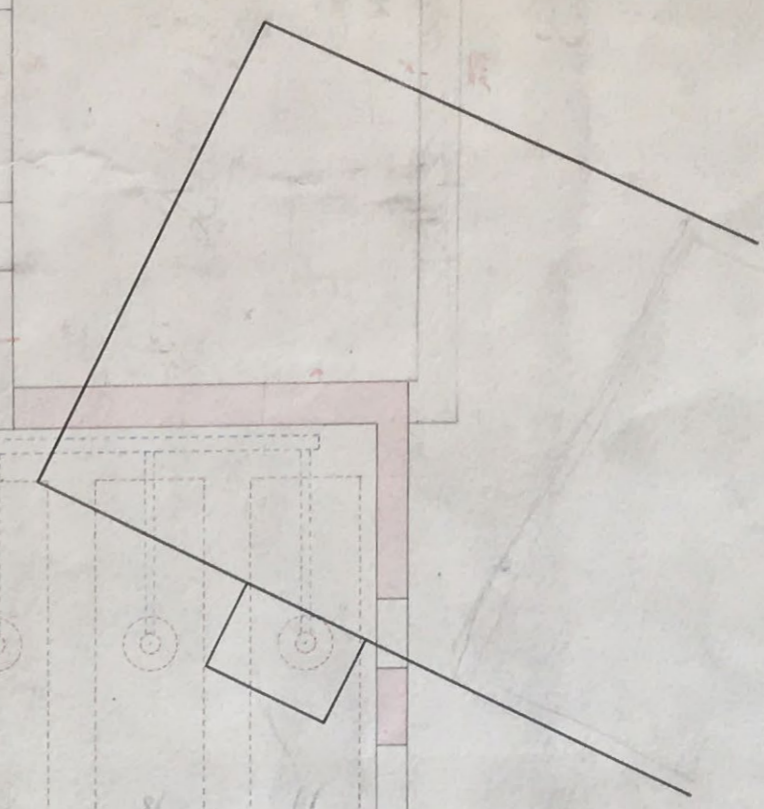
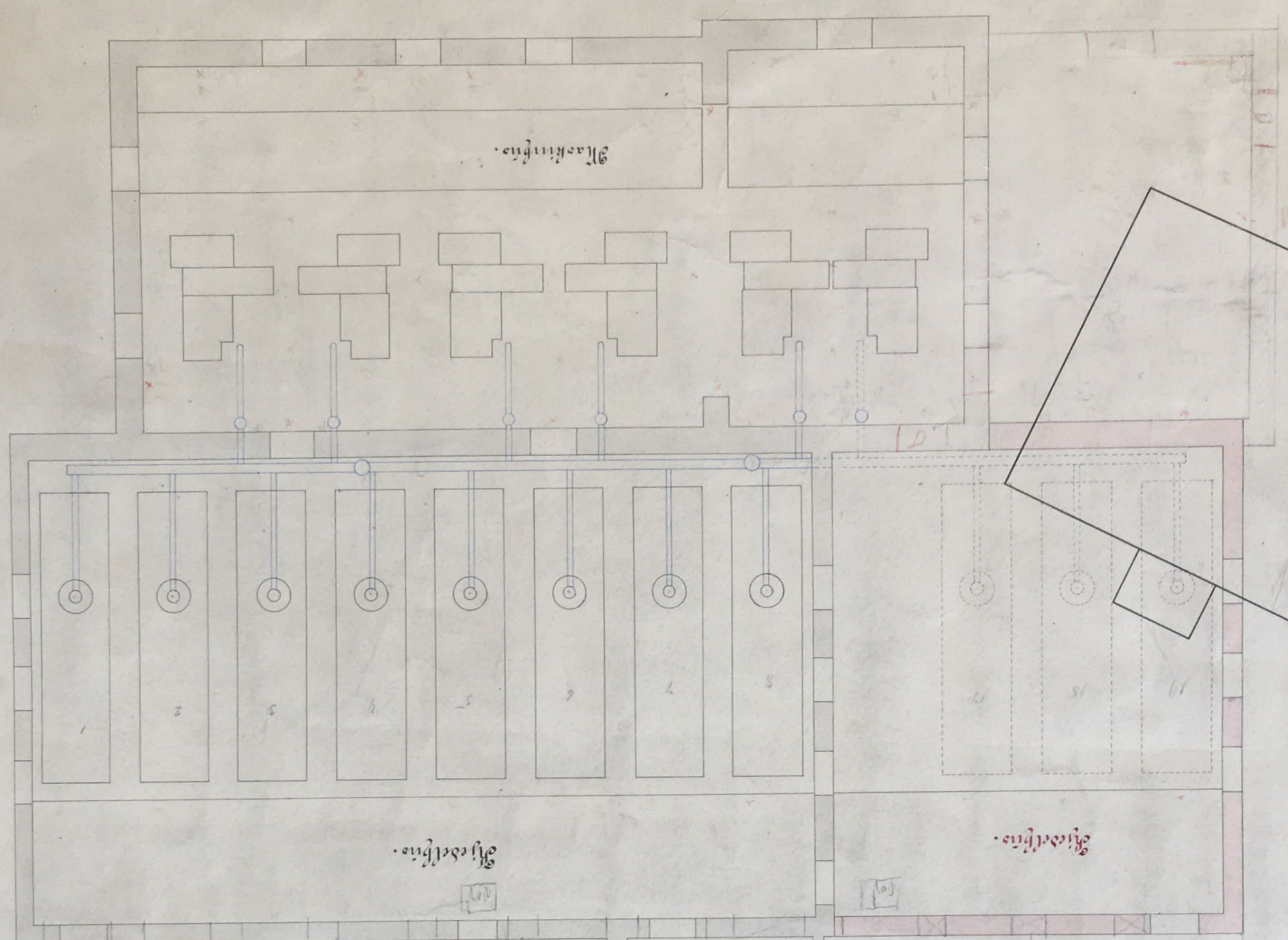
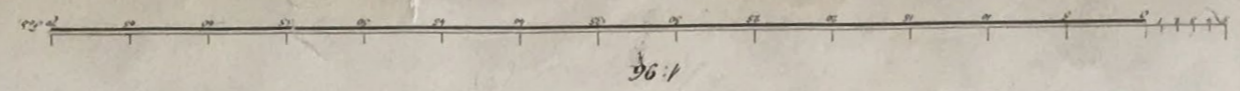

Handwritten text at the bottom right: 'Handwritten text, sm. 1884, 1884.'

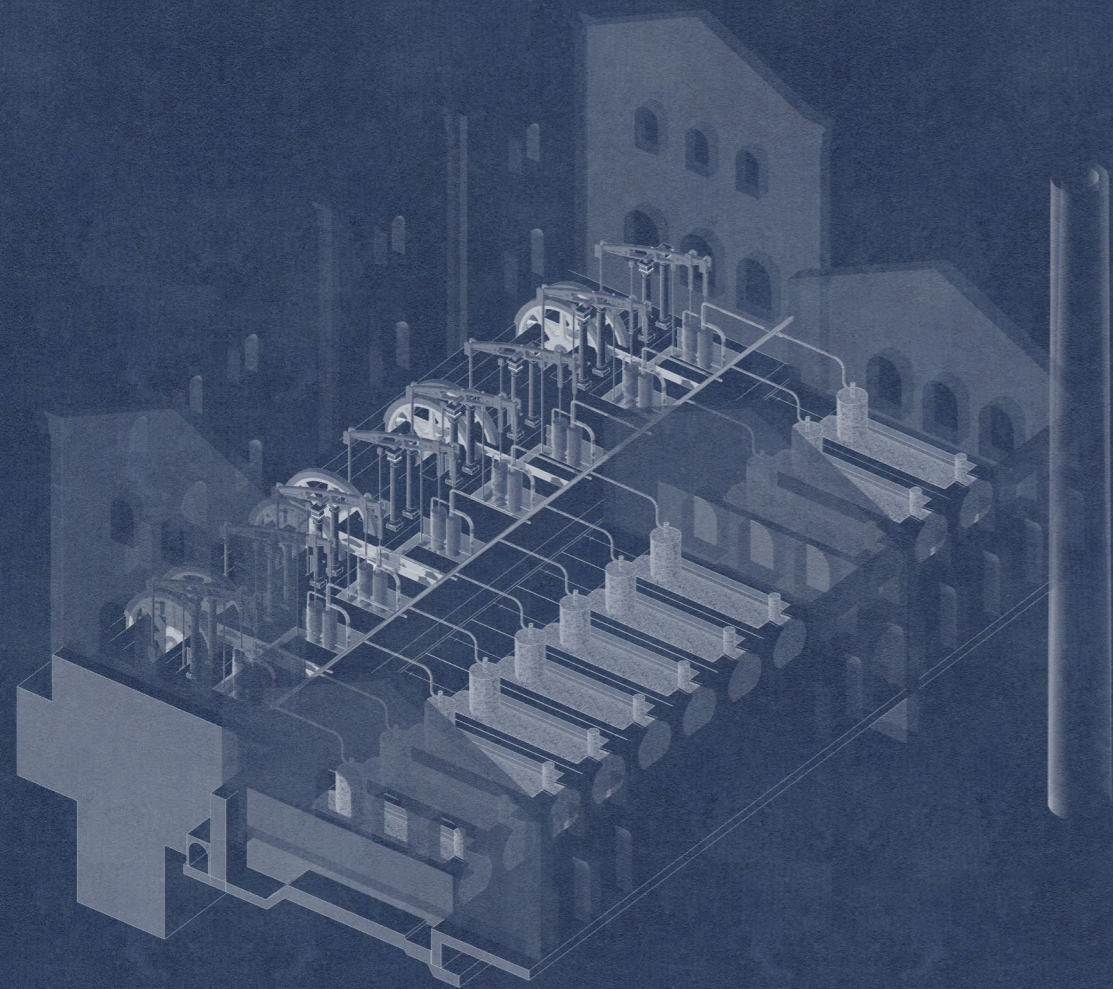

The Recovery of Machine House
A Recovery Model from the Archive Drawings



The Leftover Spaces from Machine
A Recovery Model from the Archive Drawings

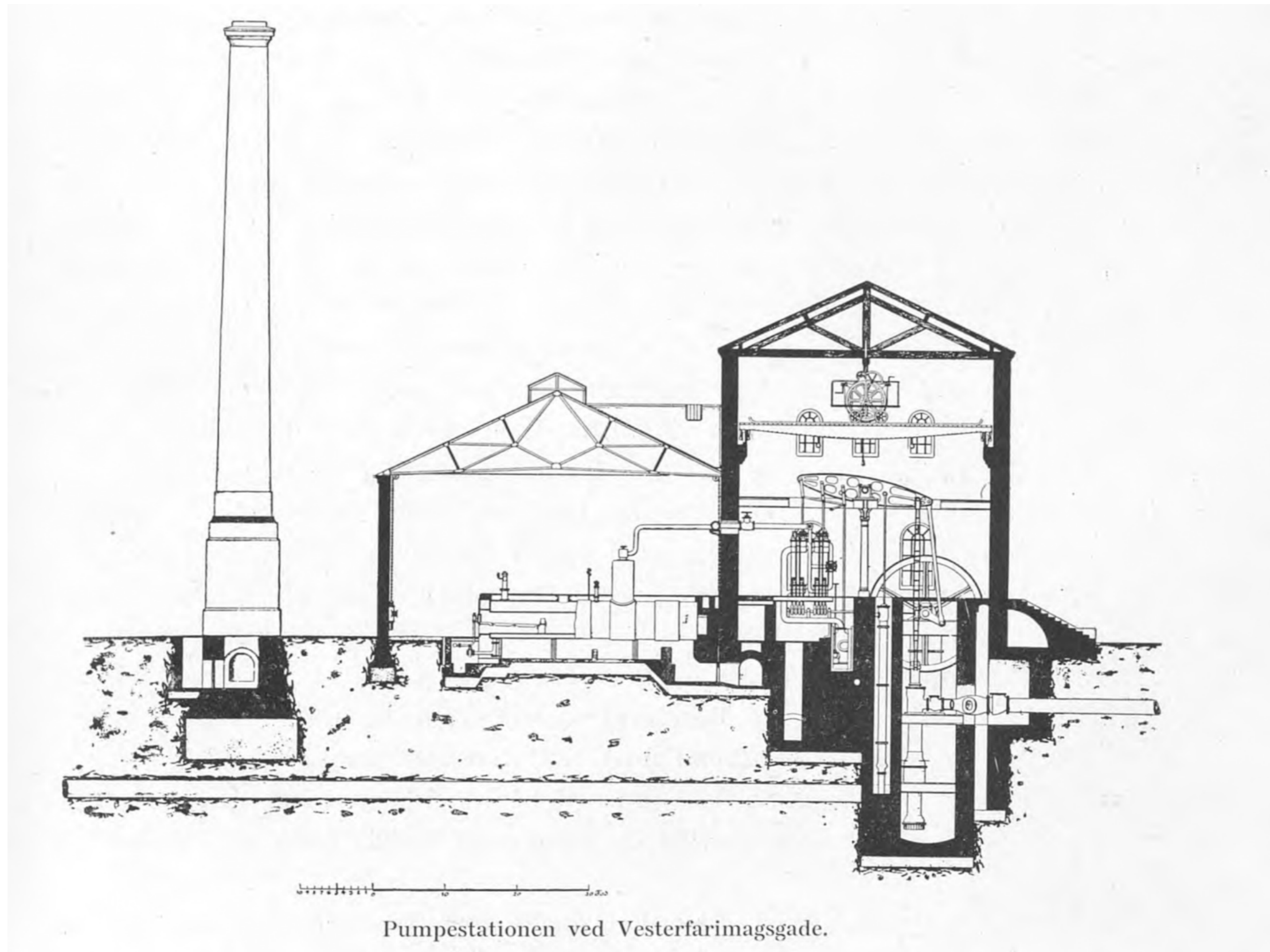

Machine House Section

Original

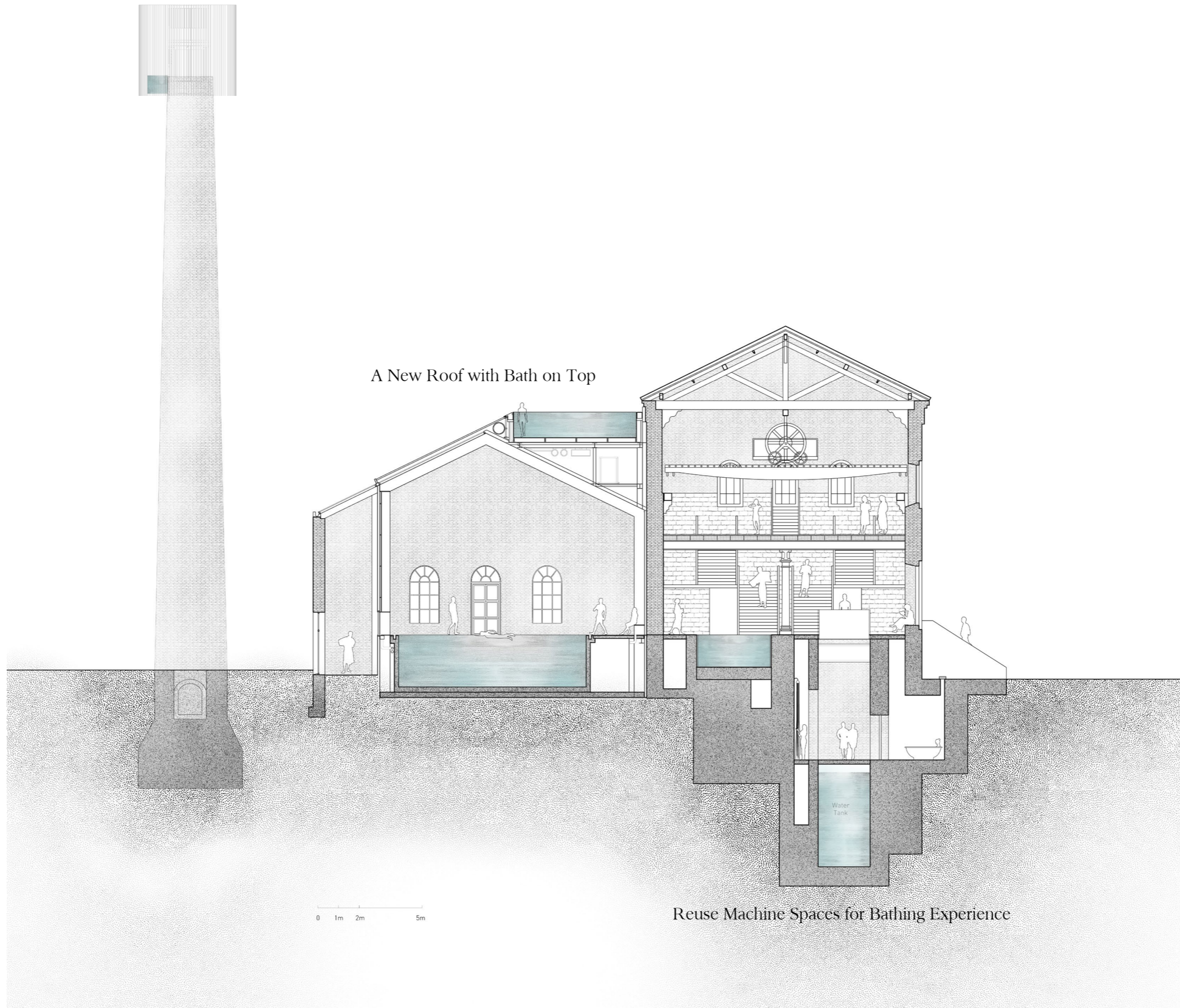

Machine House Section
Appropriation

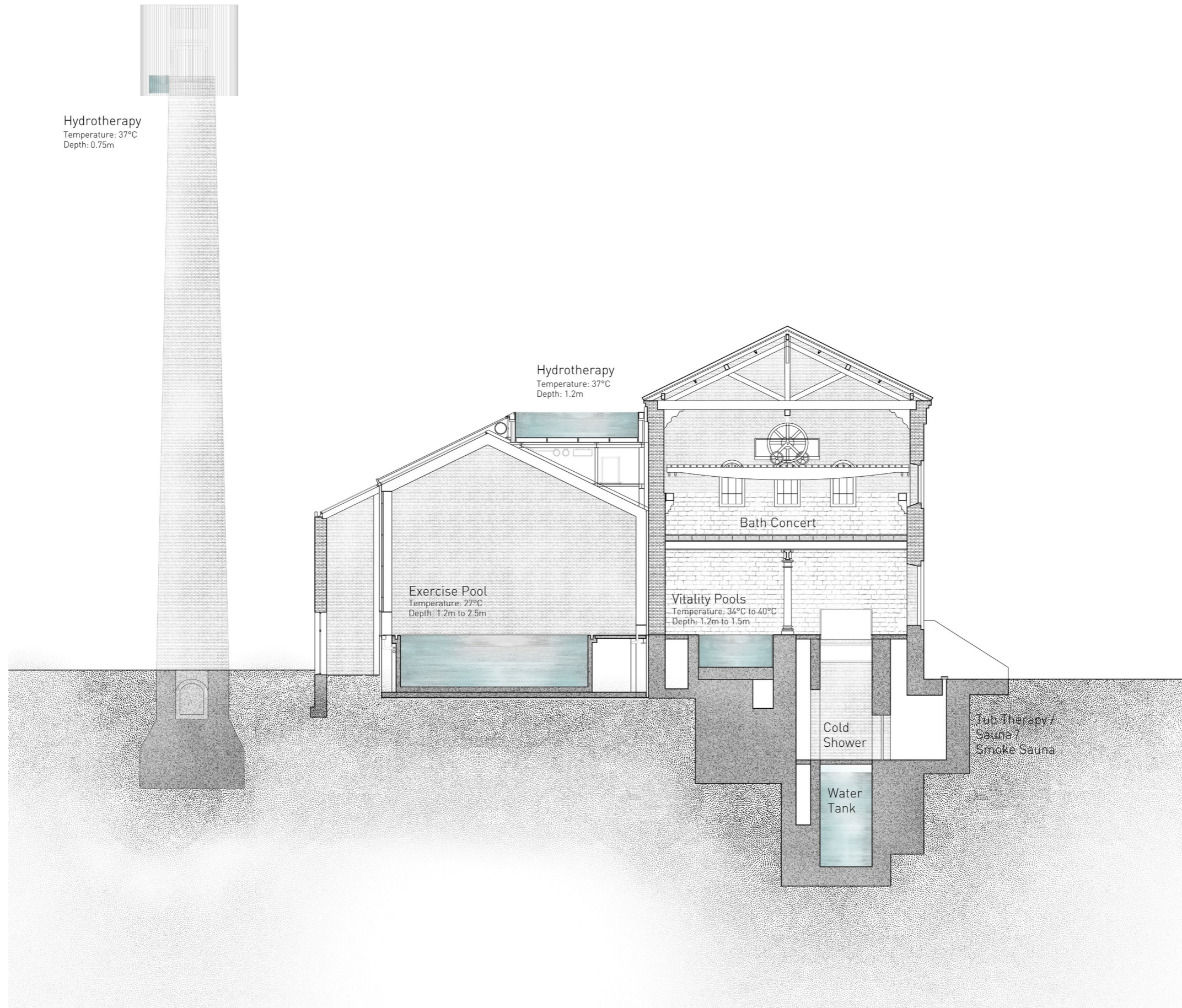

Pool Typologies
A Variety of Bathing Experience

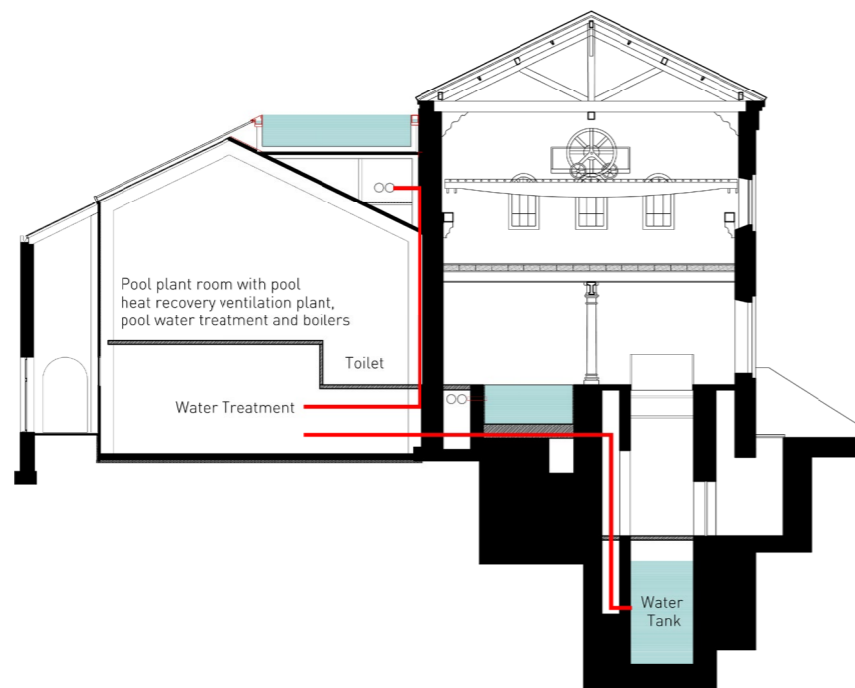

0 2m 5m 10m 20m

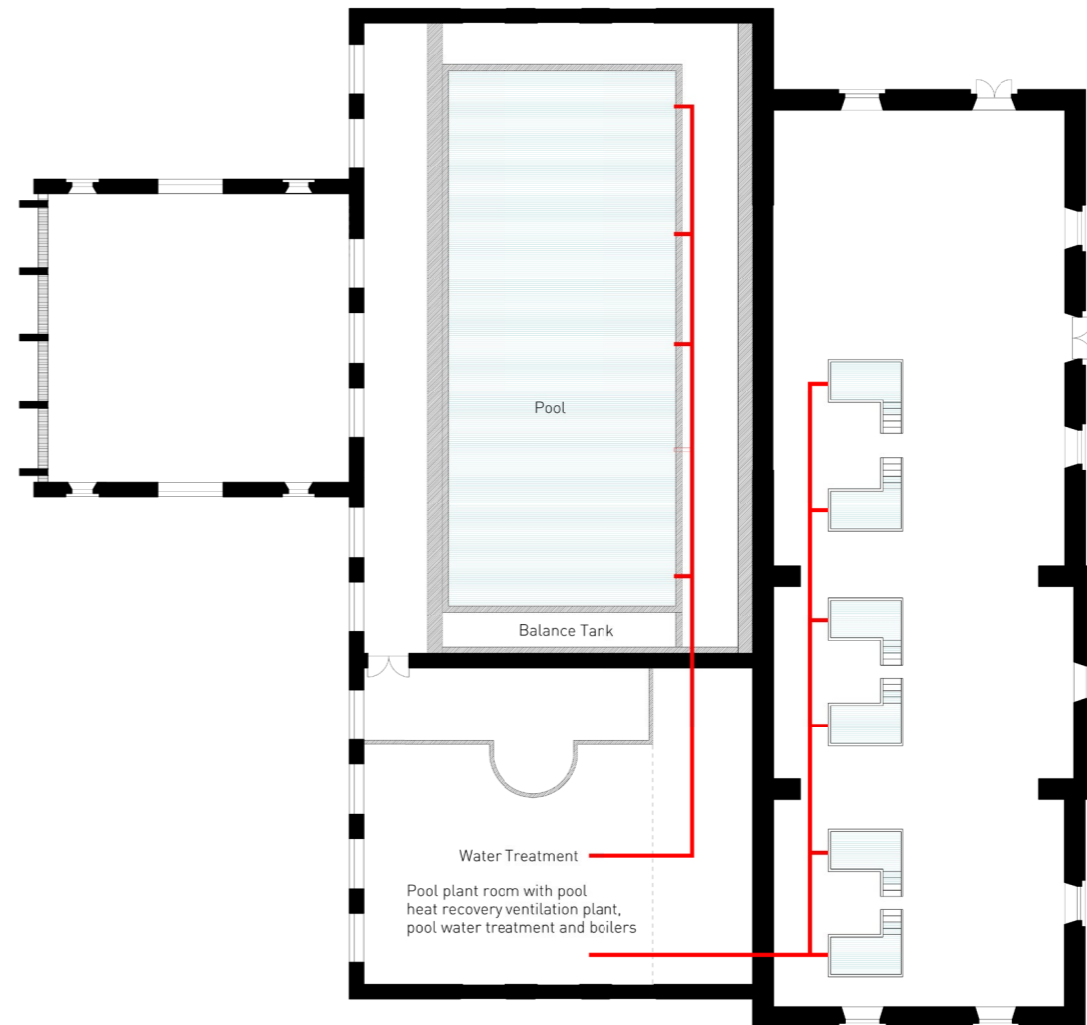

Water Treatment Strategy

1:300 Section & Plan



Chapter 03

The Collective Bath

A Transcultural Moment of Cleansing

The Collective bath shows the idea of bringing bathing experience to the urban celebration.

A combination of cleansing and celebration refers to the characteristics of this industrial monument with water and machine. It addresses the current demand of the city for more bathing facilities, where more and more cultural events were held.

In those celebrations, in the cultural event, everyone becomes pure and transparent. The experience of bathing brought the ultra- intimacy to the celebrations. That is when the transcultural moments happen.

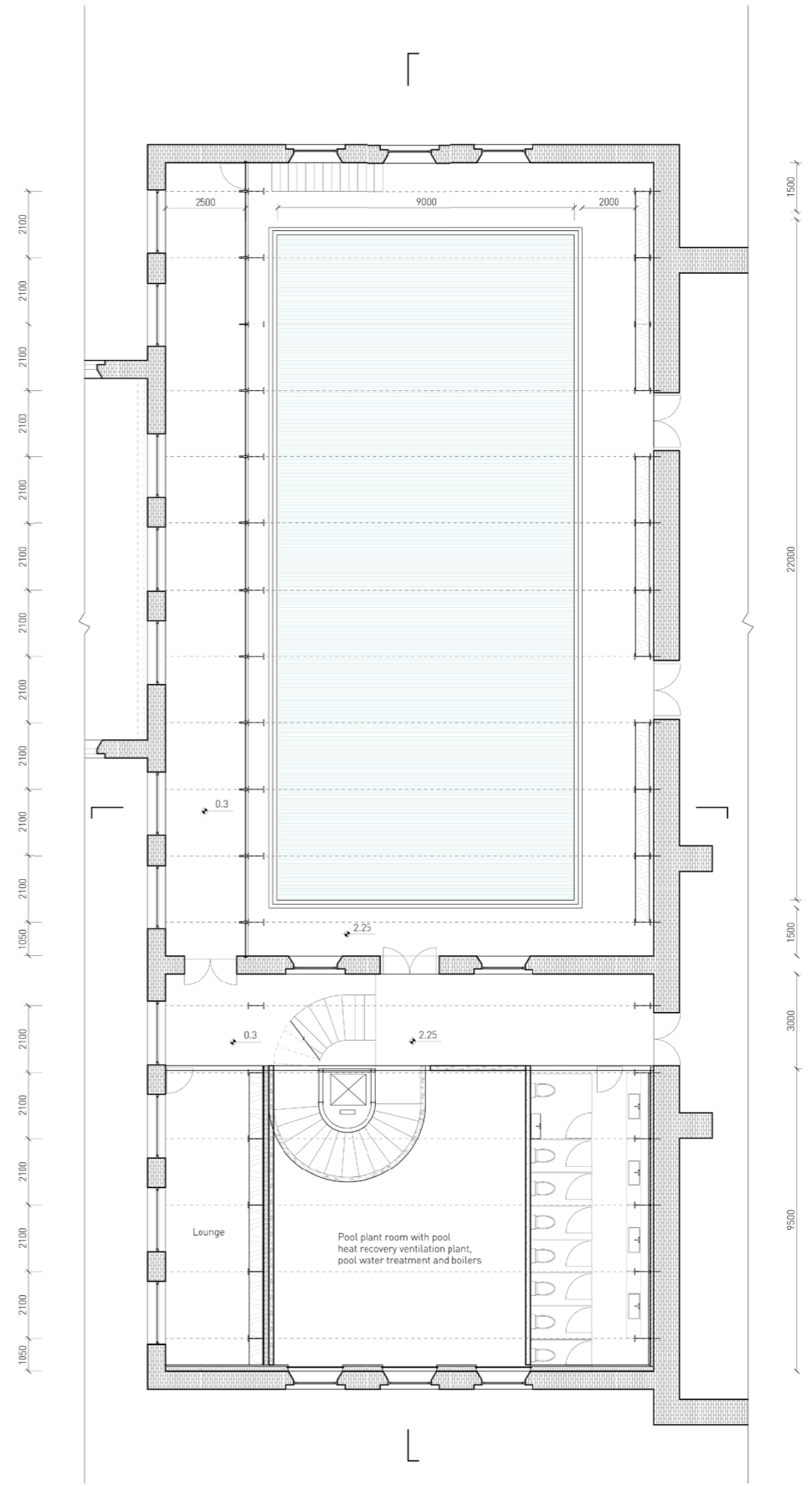

Boiler House Plan (Collective Bath)

1:200

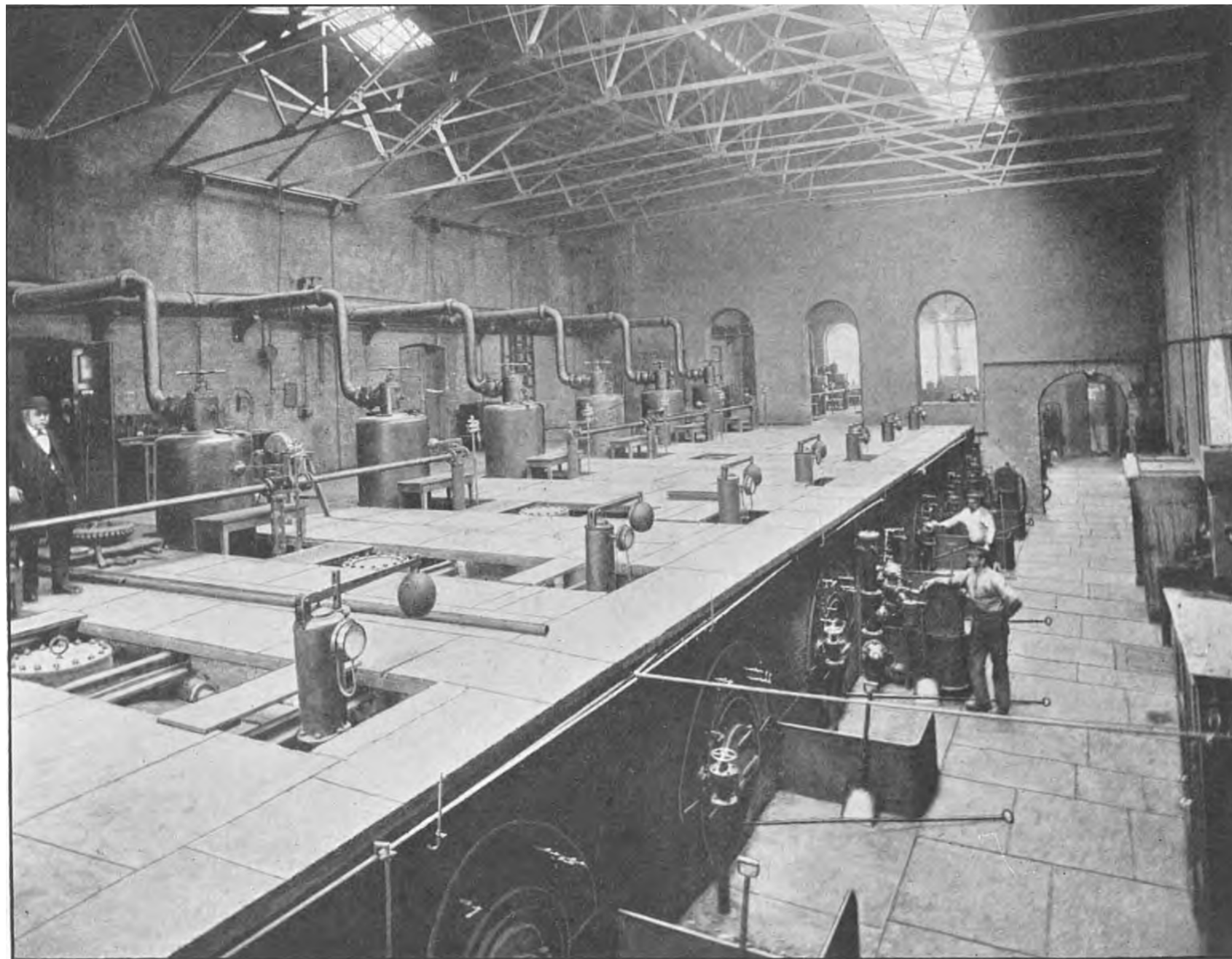

Ældre Kedelanlæg ved Vesterfarimagsgade.

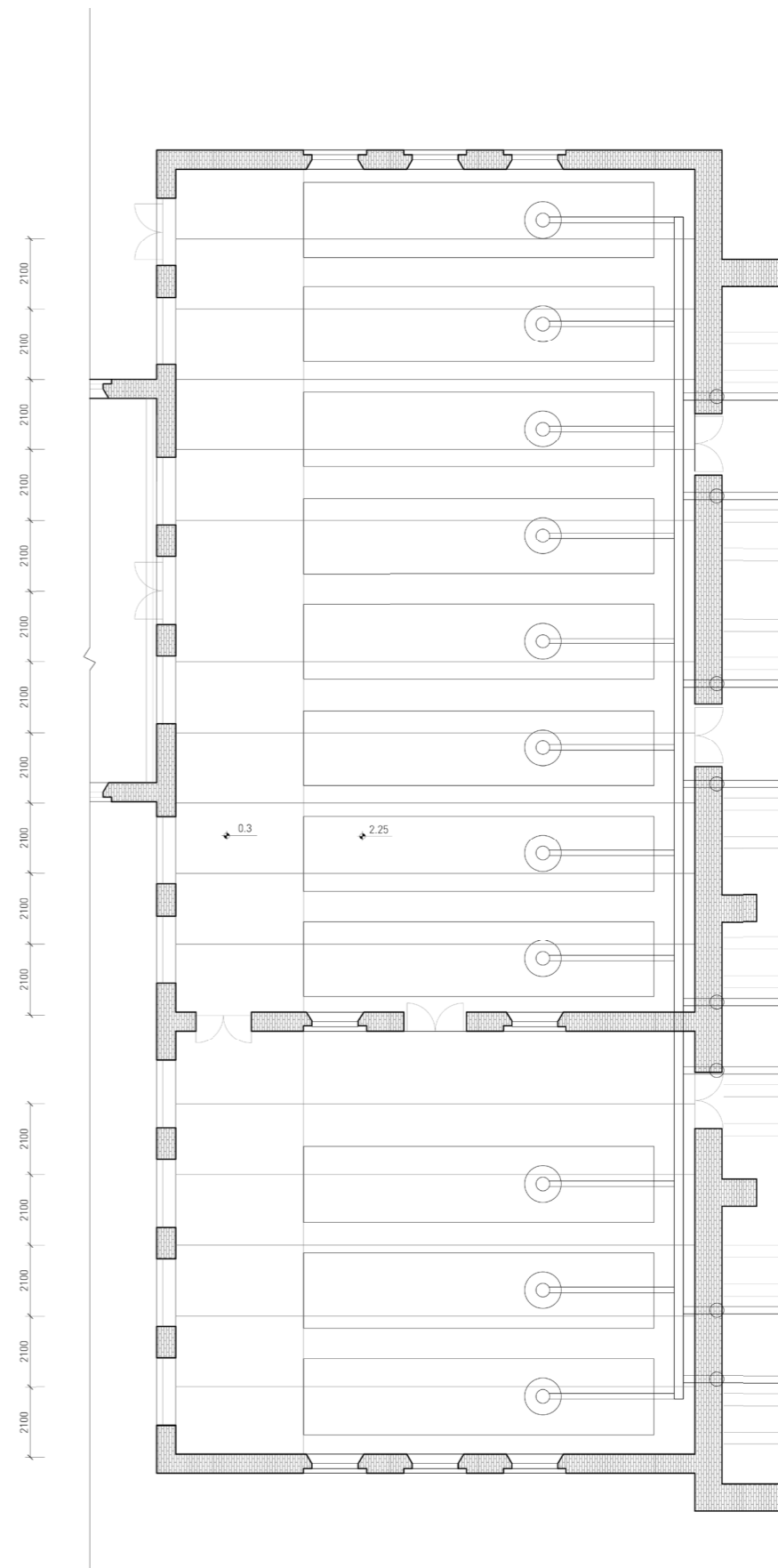

Boiler House Plan (Machine Layout)

1:200

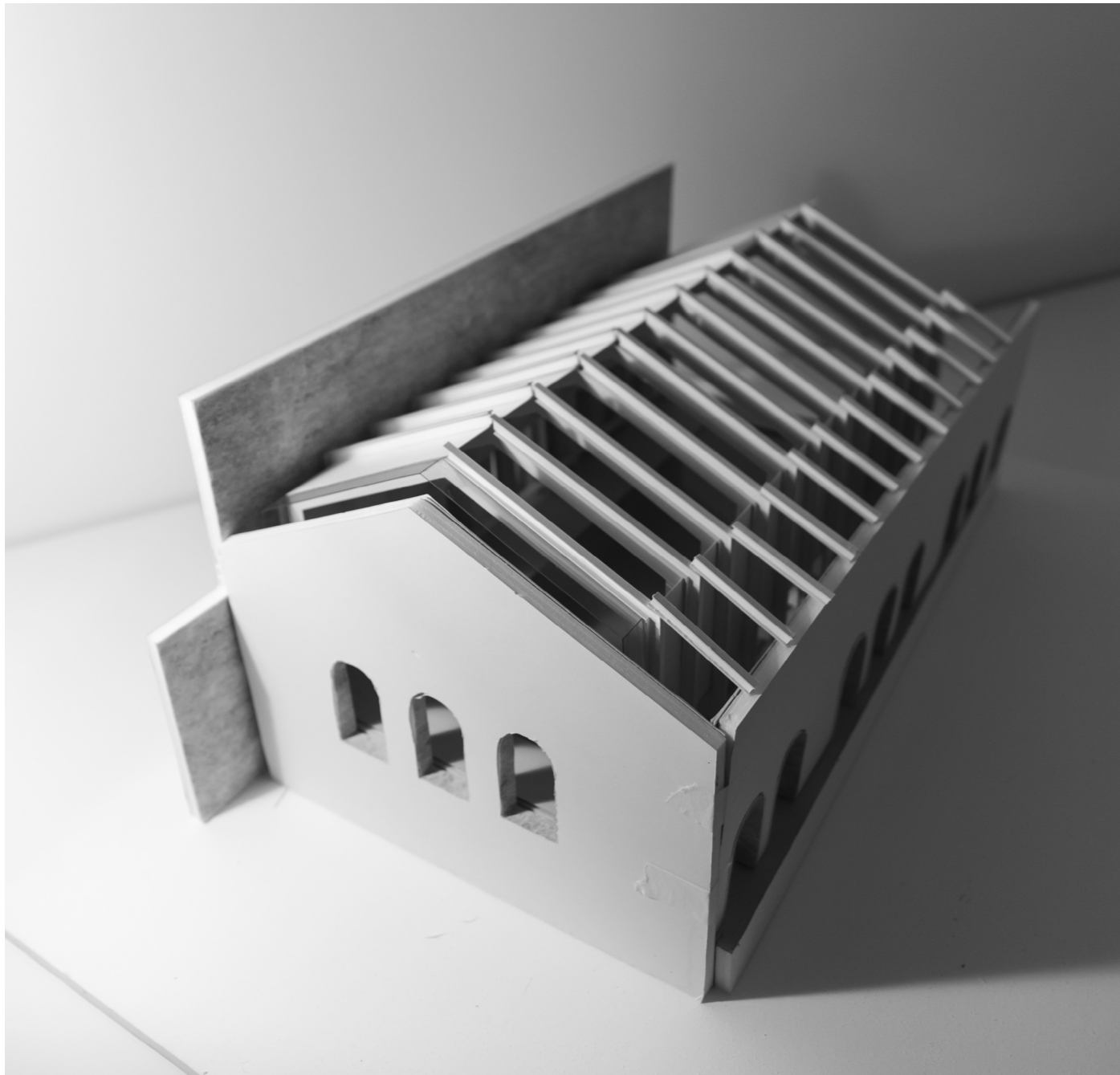

Structure Model
1:50 Interior Study Model

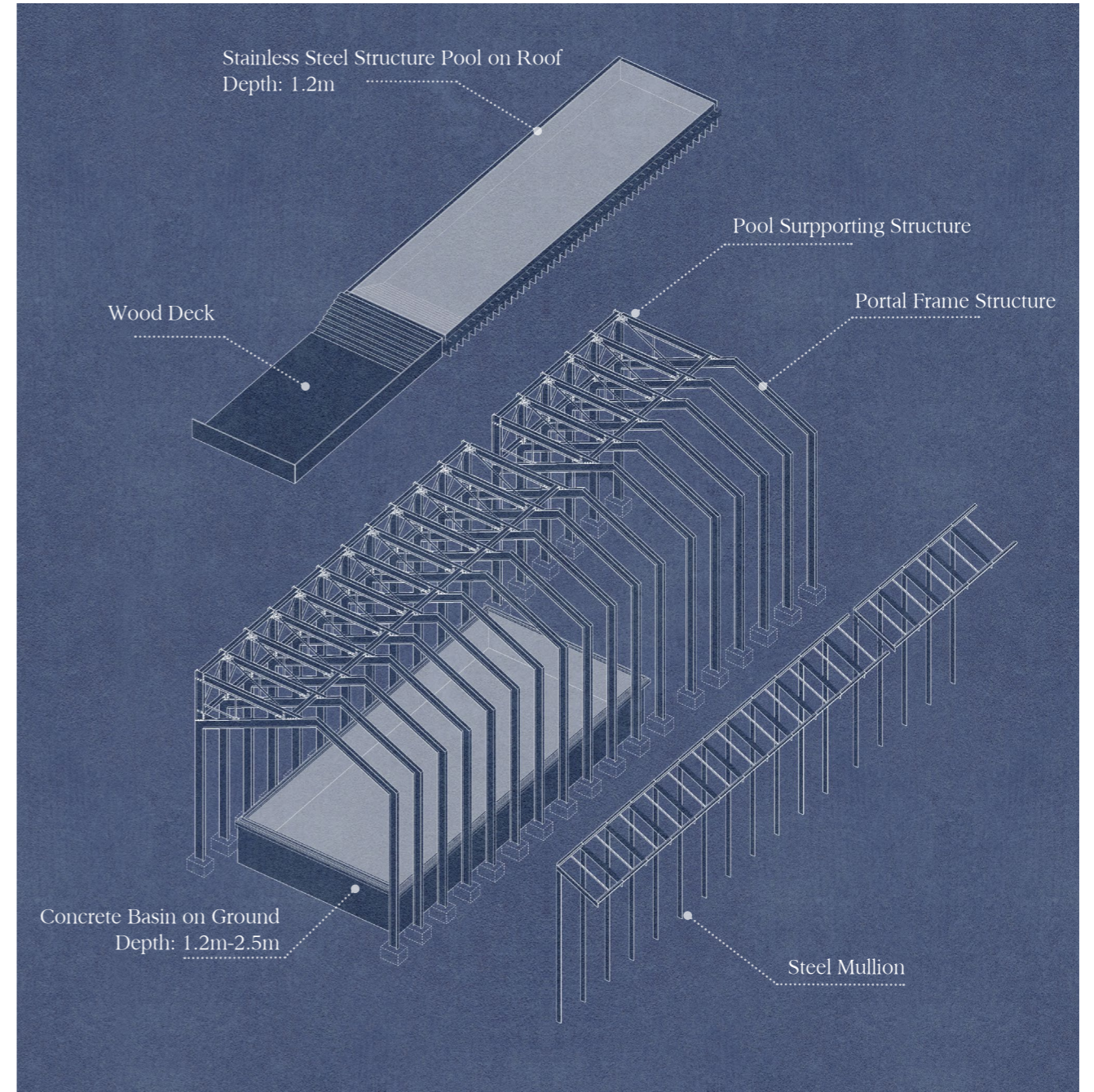

Loadbearing Structure
1:50 Interior Study Model

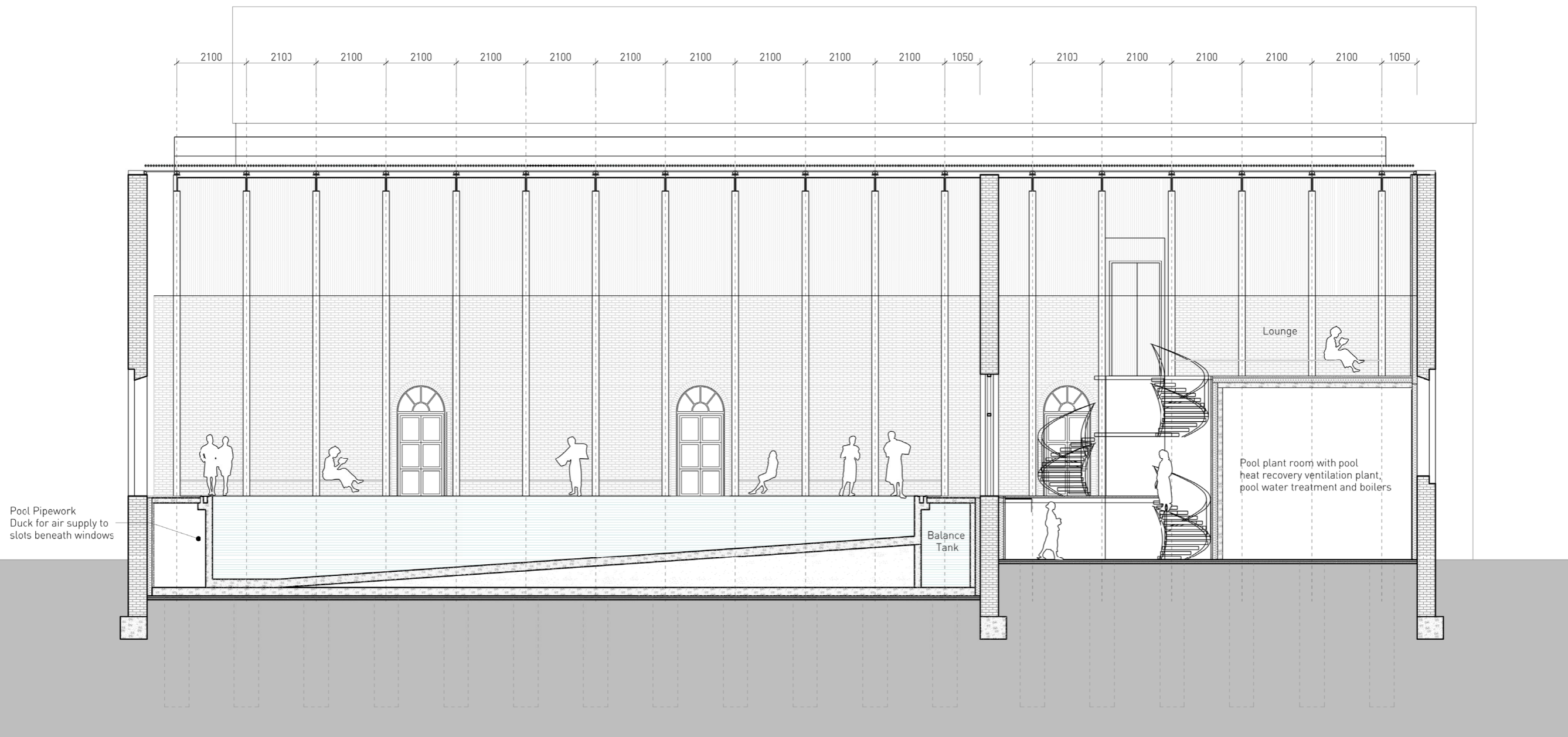

Longitudinal Section of Boiler House (Collective Bath)

1:75



Interior Pool

Interior View Towards Old Brick Wall



View Towards Corridor
Water Reflection of Old and New



Interior of Exercise Pool
1:50 Interior Study Model

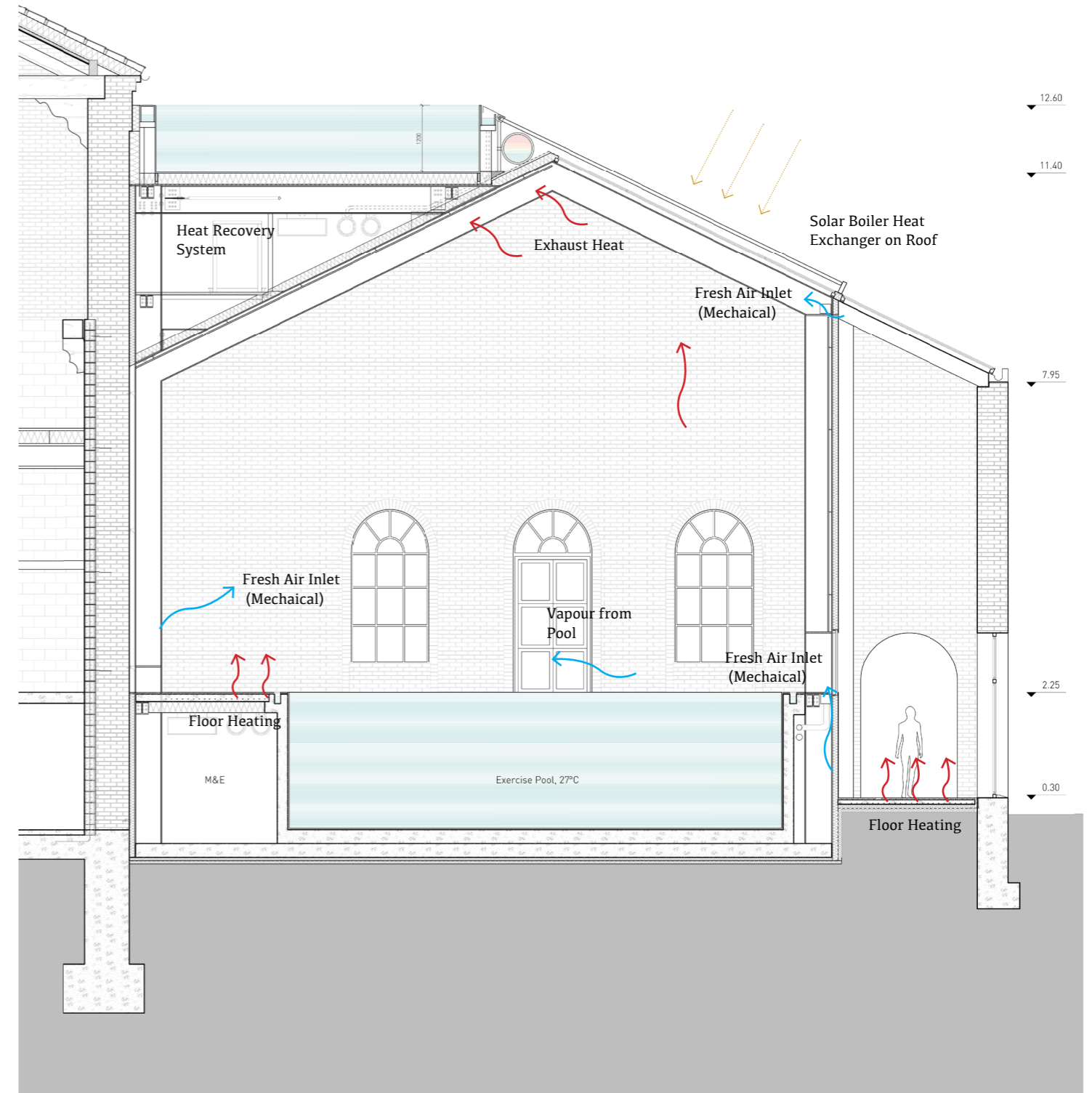

Climate Strategy for Winter
1:100 Cross Section

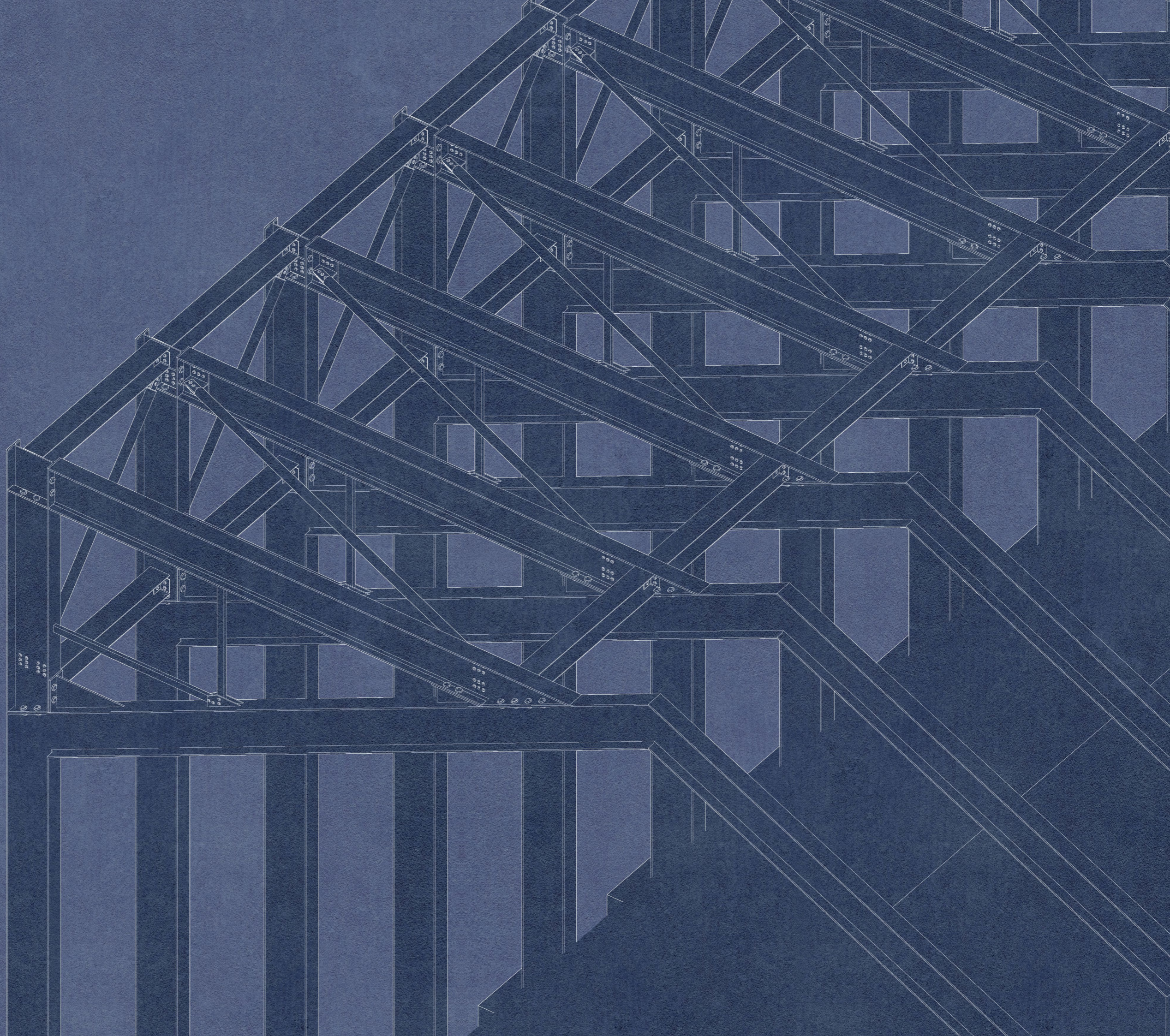

Strengthened Steel Structure
Pool Supporting Structure

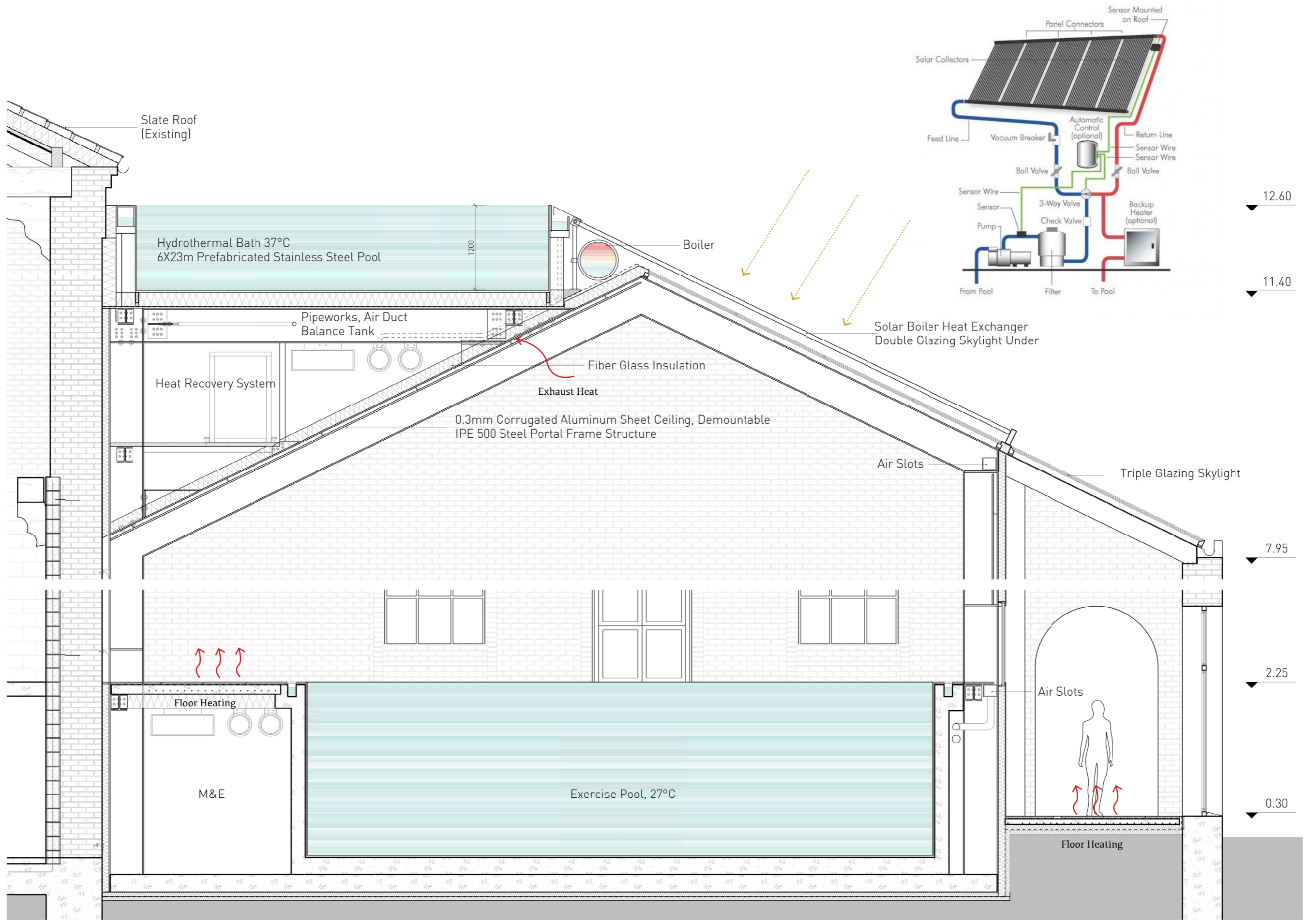

FACADE FRAGMENT
1:50

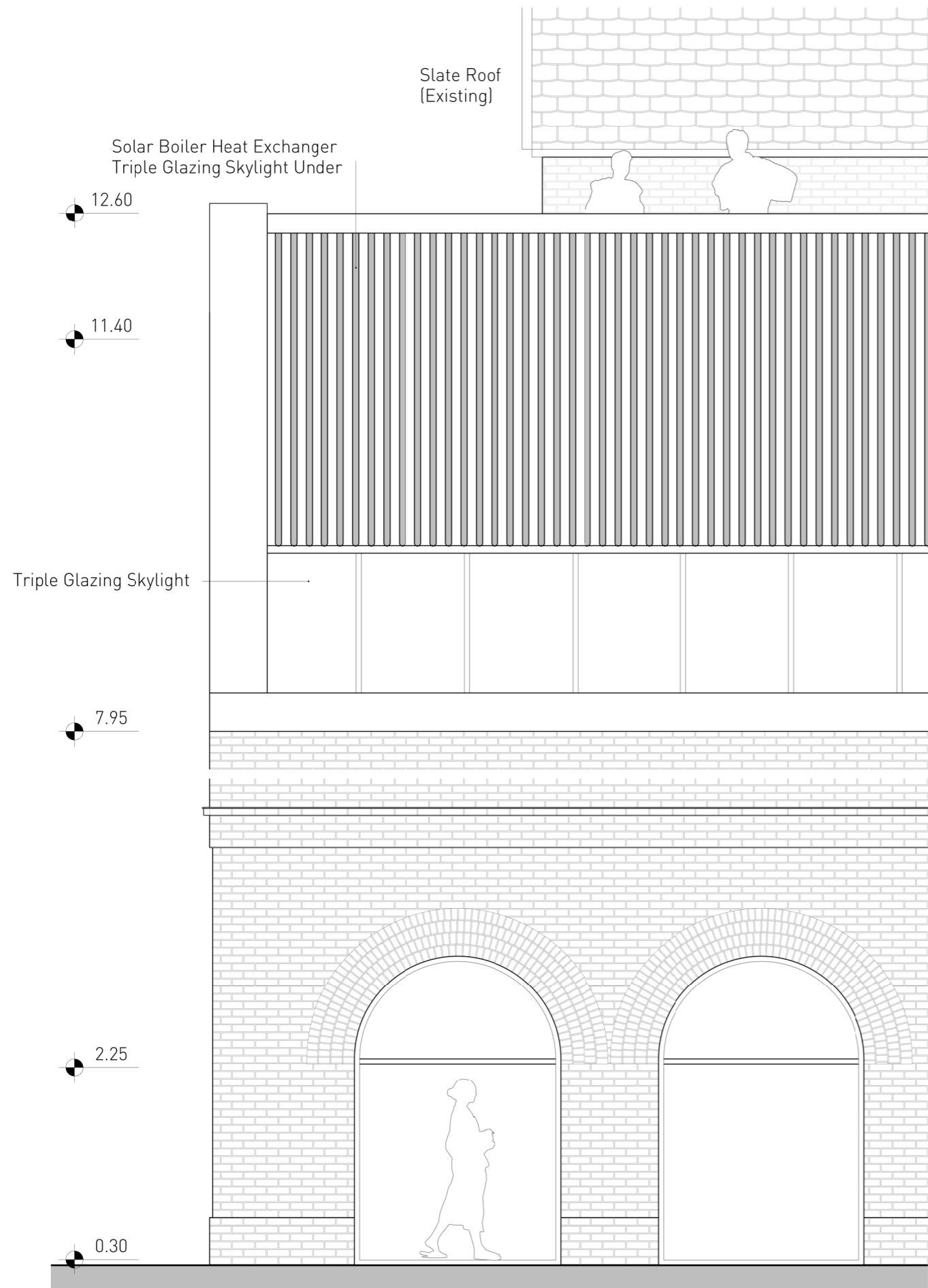

FACADE FRAGMENT
1:50



The Collective Pool
View Towards Corridor

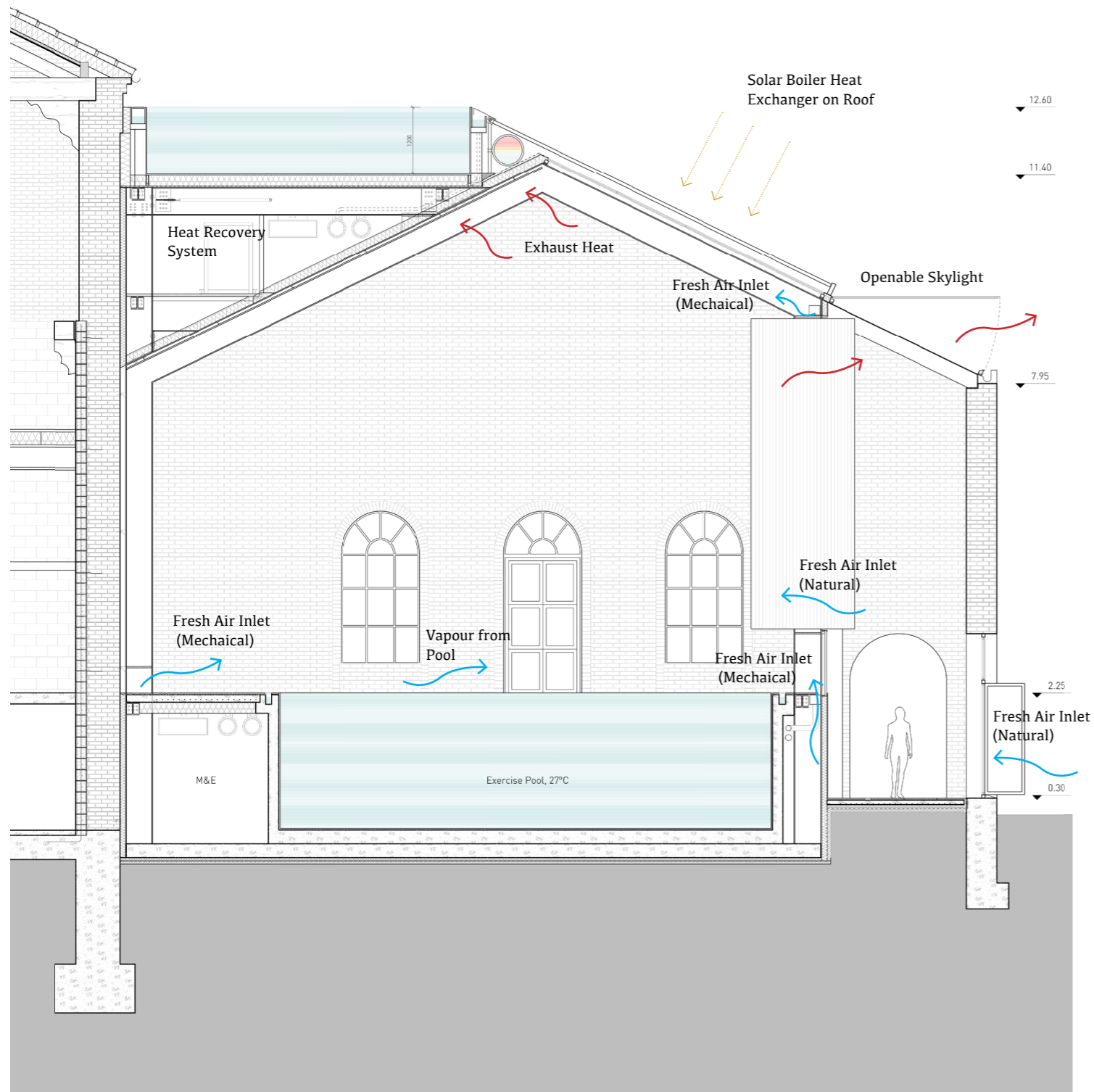

Climate Strategy for Summer (Further Study)

1:100 Cross Section



The Collective Pool

A Possibility of Rotating Panel

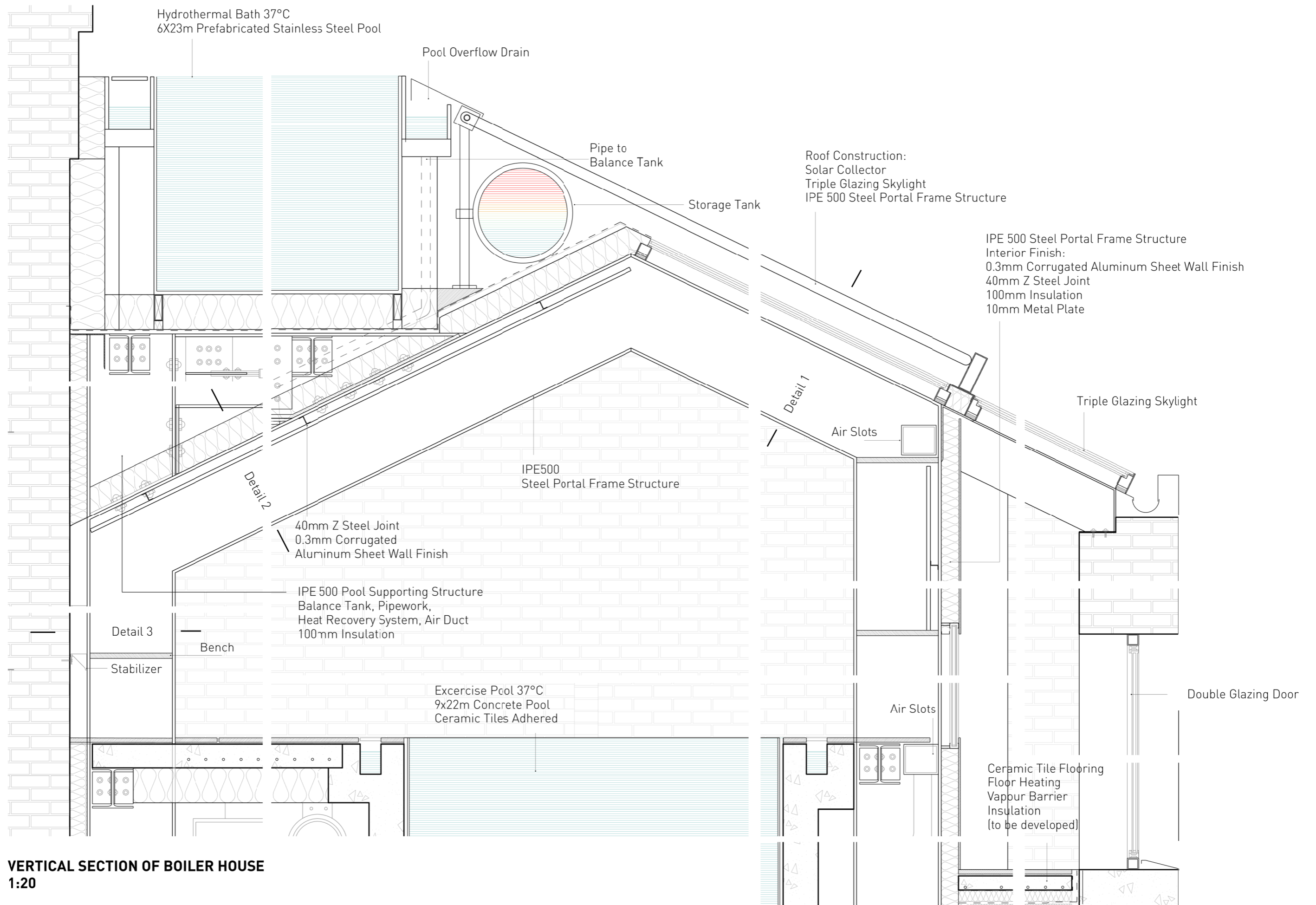

VERTICAL SECTION OF BOILER HOUSE
1:20

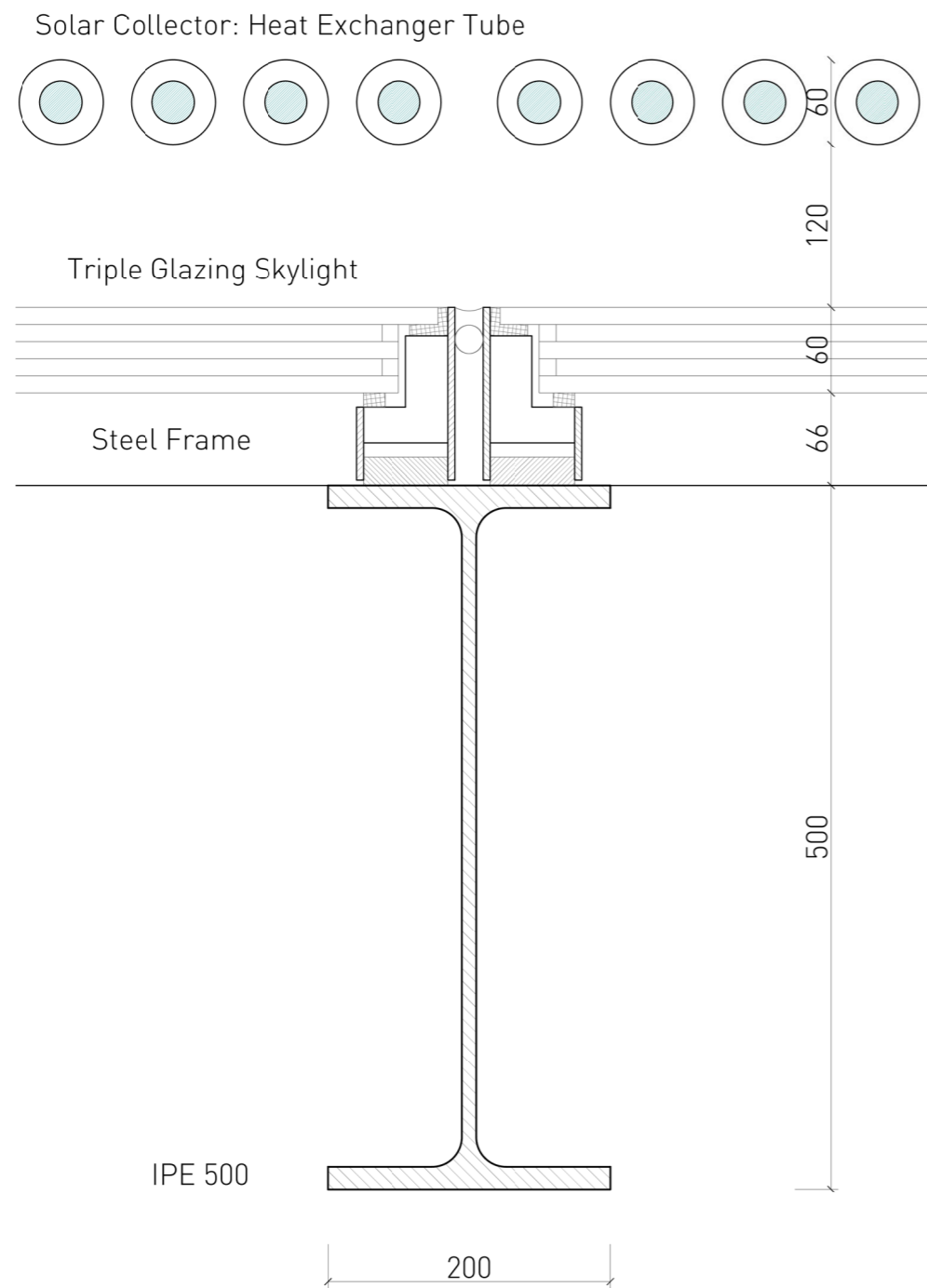

DETAIL 1: SKYLIGHT
1:5



Solar Boiler System on Top of Roof

1:250 Study Model



Steel Frames and Corrugated Ceiling Panels
View Towards Pumphouse

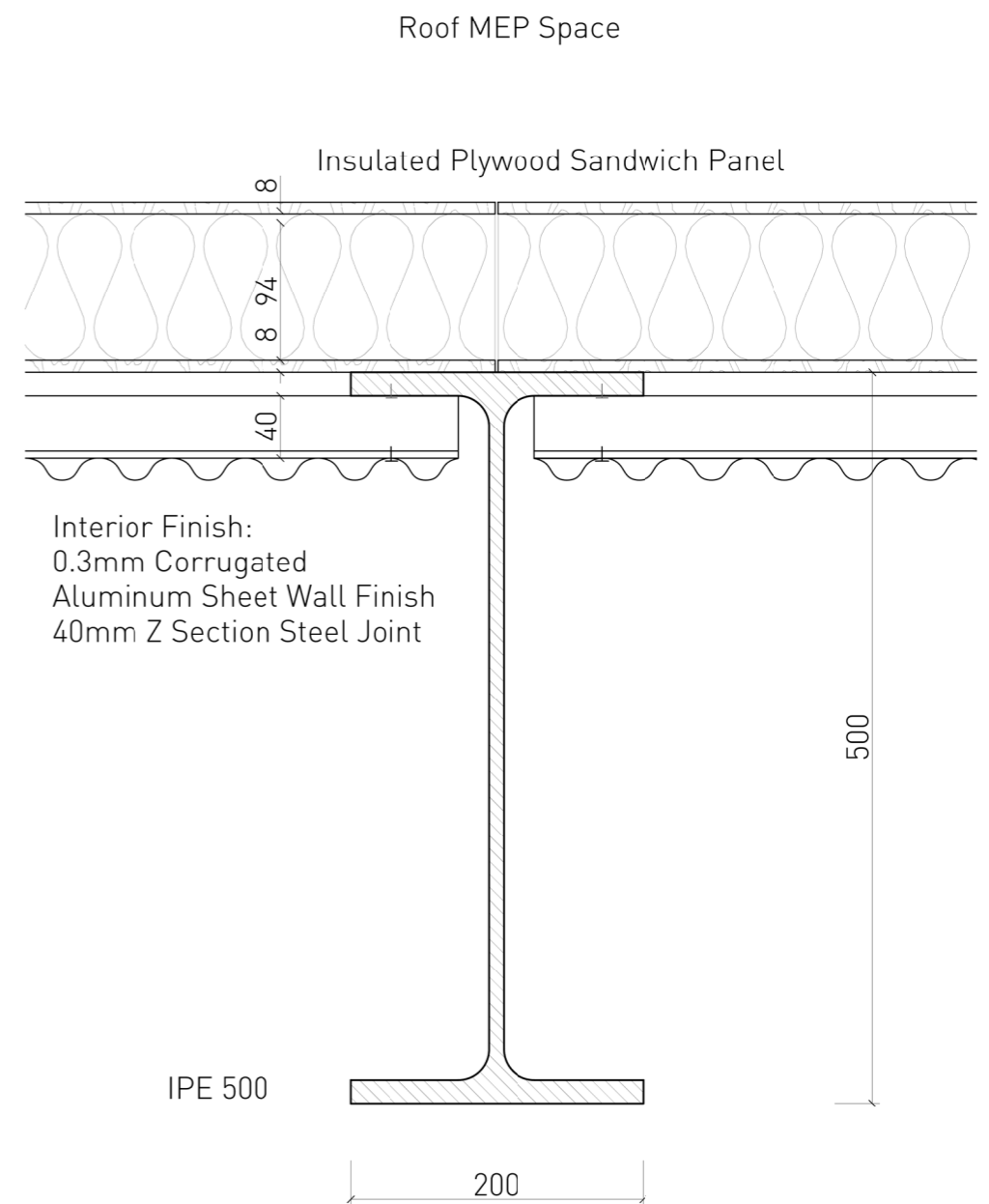

DETAIL 2: CEILING
1:5

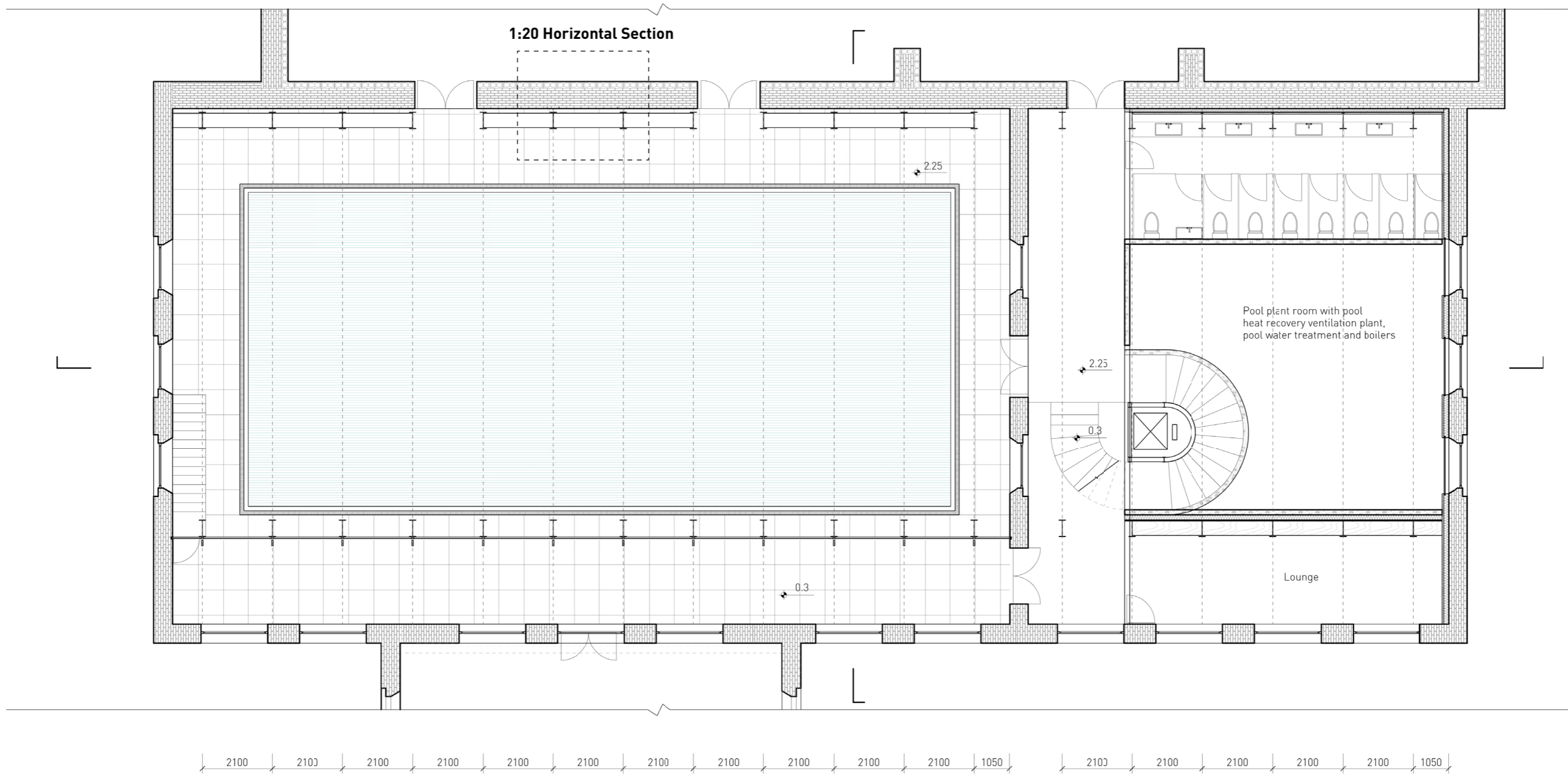

Plan of Boiler House (Collective Bath)

1:75

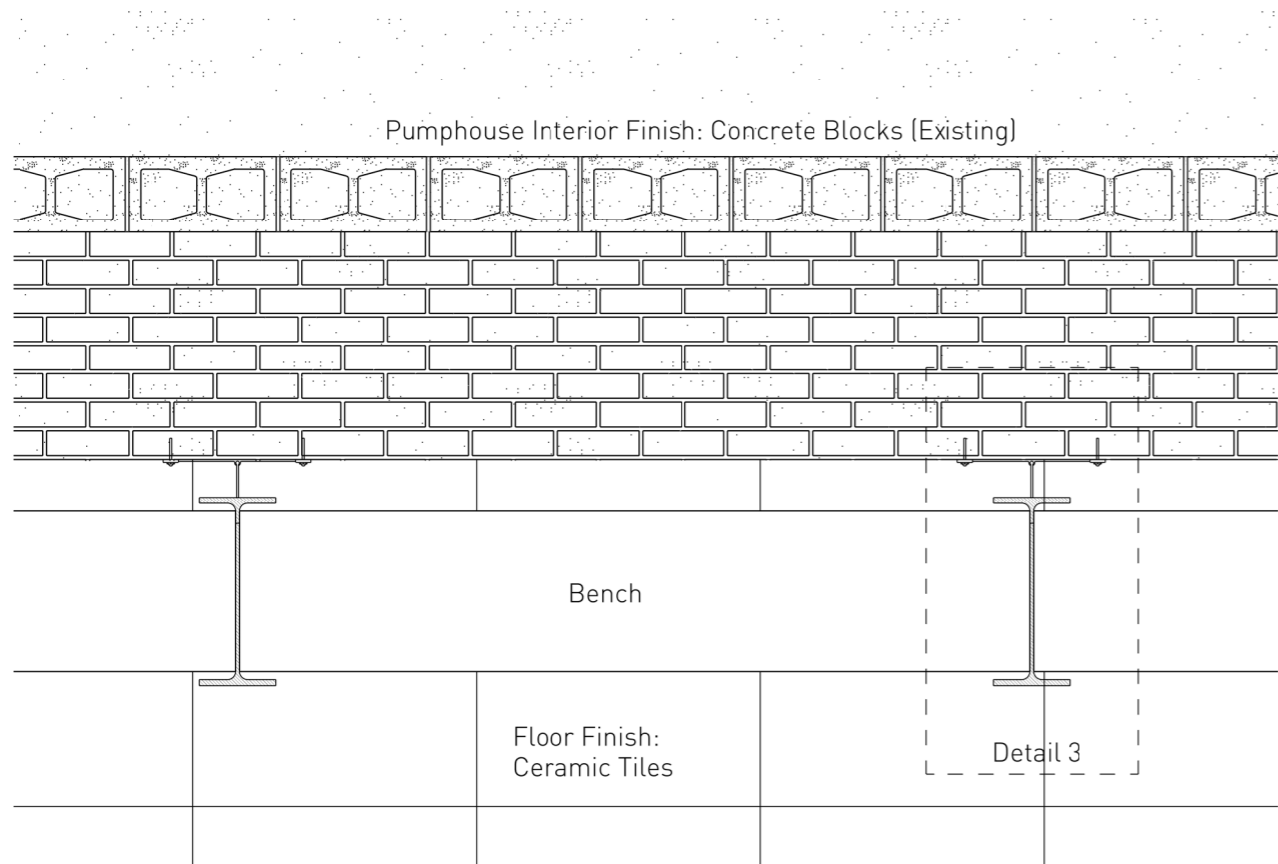

HORIZONTAL SECTION OF BOILER HOUSE
1:20

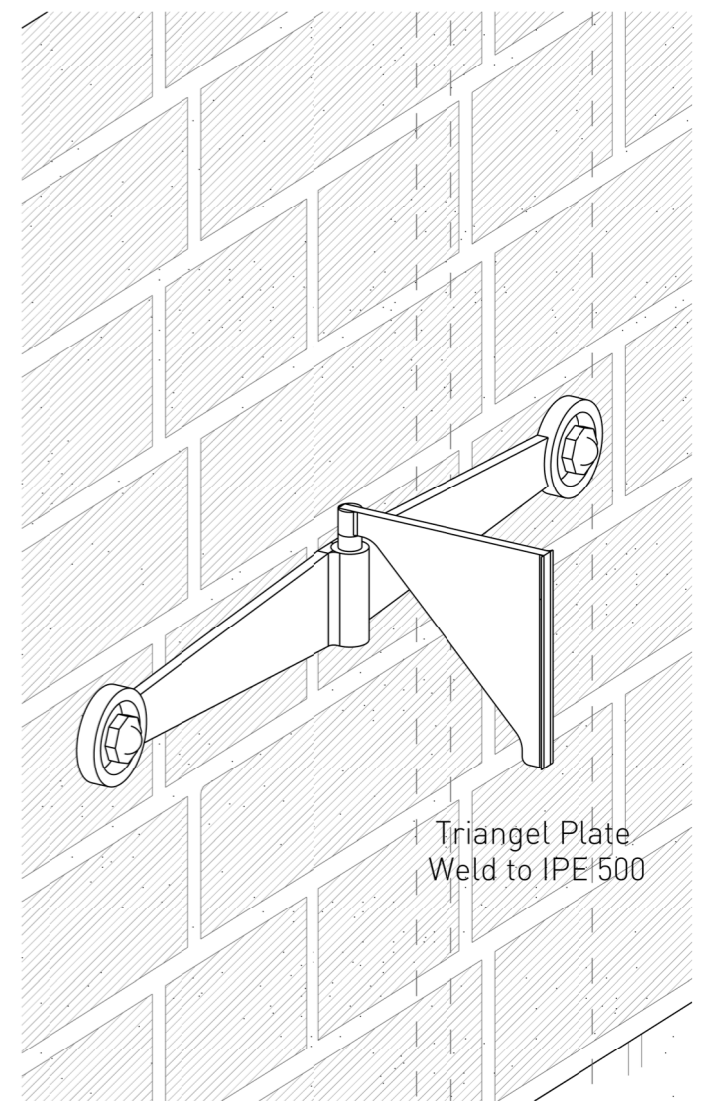
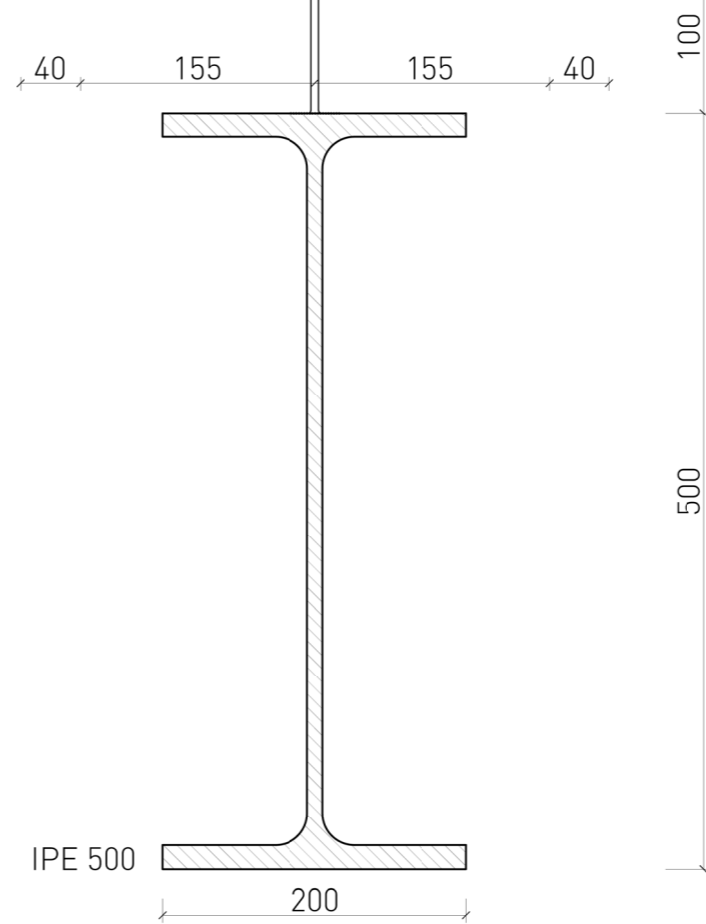
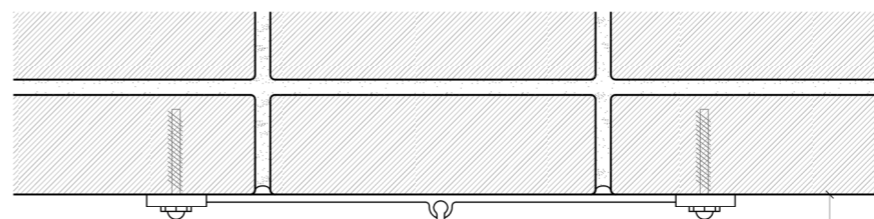
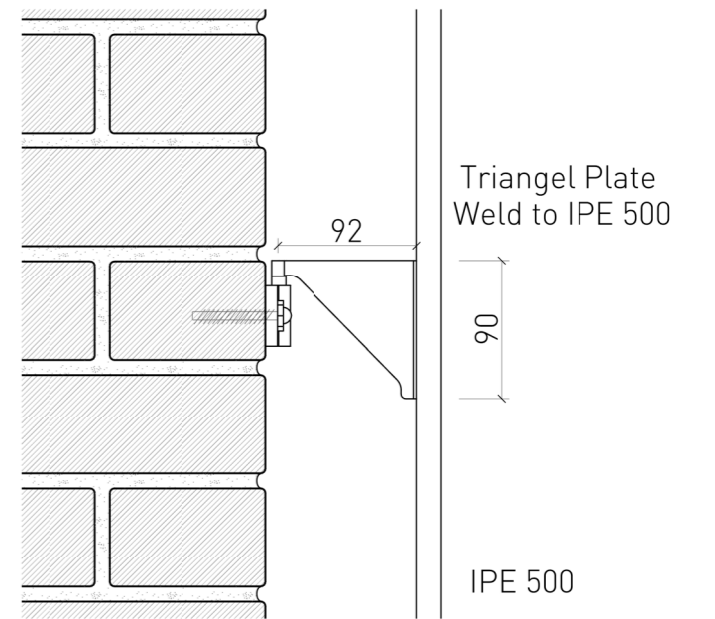
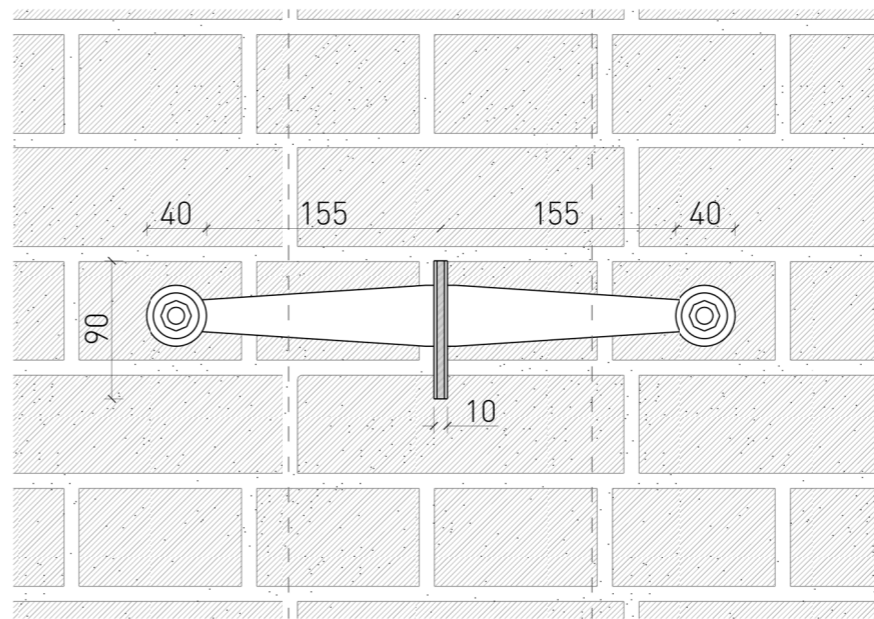

DETAIL 3: ANCHOR ON BRICK WALL
1:5

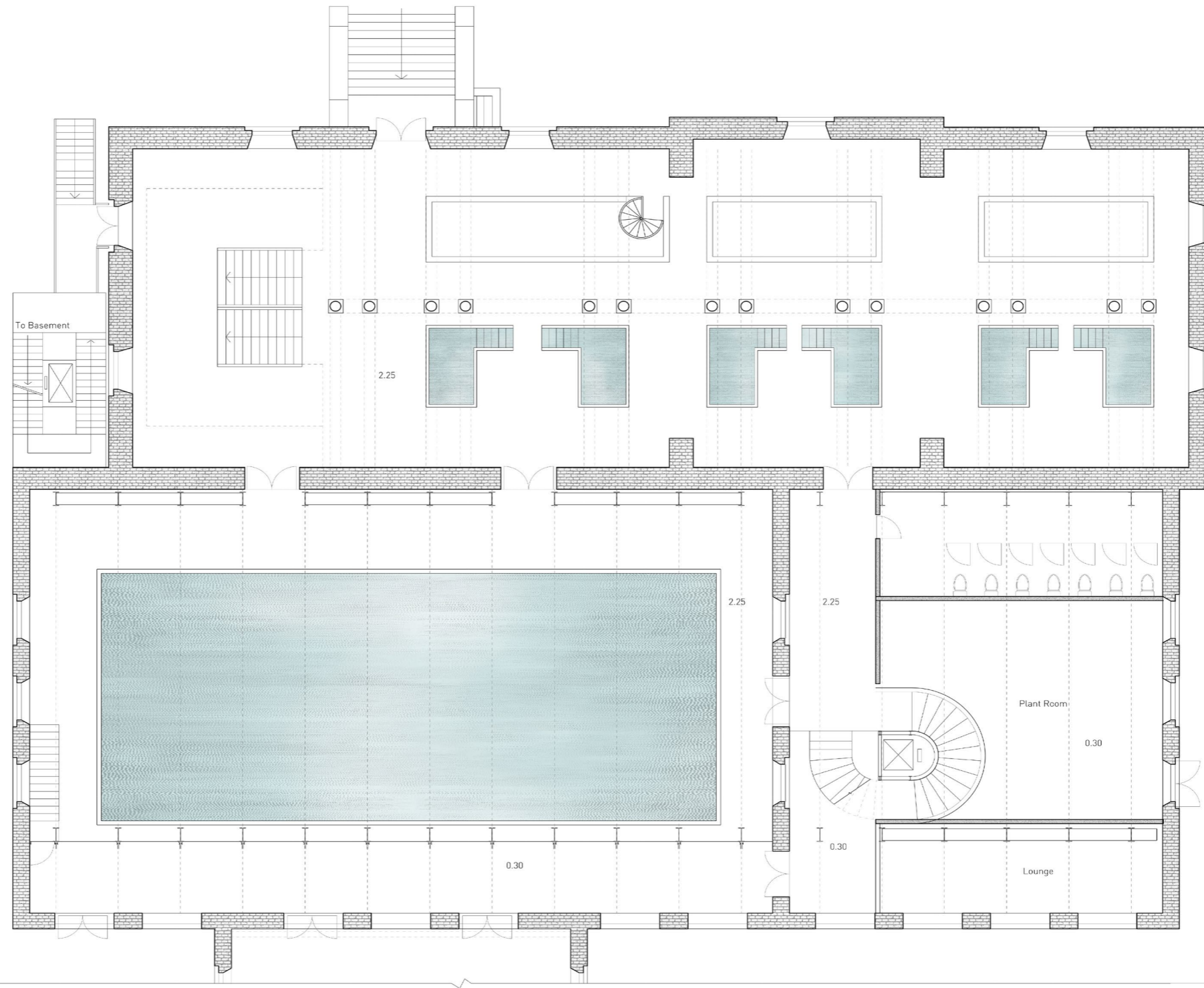

Interior of Pumpehuset Ground Floor

A Place of Secret Meeting



Interior of Pumpehuset Ground Floor

Current



Interior of Pumpehuset Ground Floor

Reappropriation

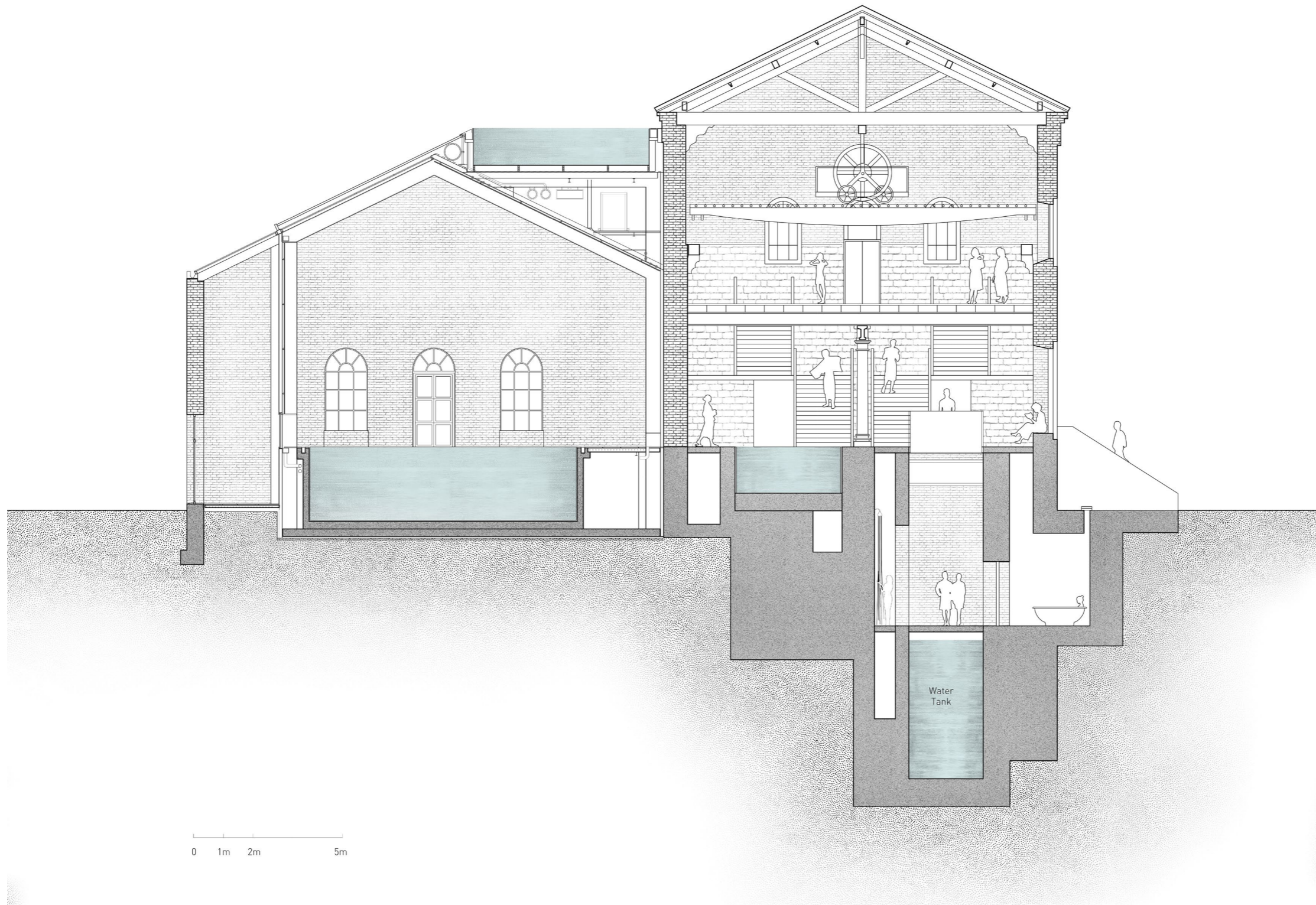

Cross Section of Pumphouse

A Variety of Bathing Experience



Chapter 04

The Experiential Bath

The Reappropriation for Private Meeting and Intimate Cultural Events

After the Sanitation Movement, private bathrooms were required in the new housing as a basic welfare system. Most of the bathhouses around Copenhagen were demolished. Only a few were left, and the individual shower cells were expanded for social purpose. Cultural events such as concert, are often arranged in these places.

In the reappropriation of Pumhouse, a model of danish bath was referred. It shows how the individual bath cubes has been transformed into a place of private meeting, a place of intimate cultural events.

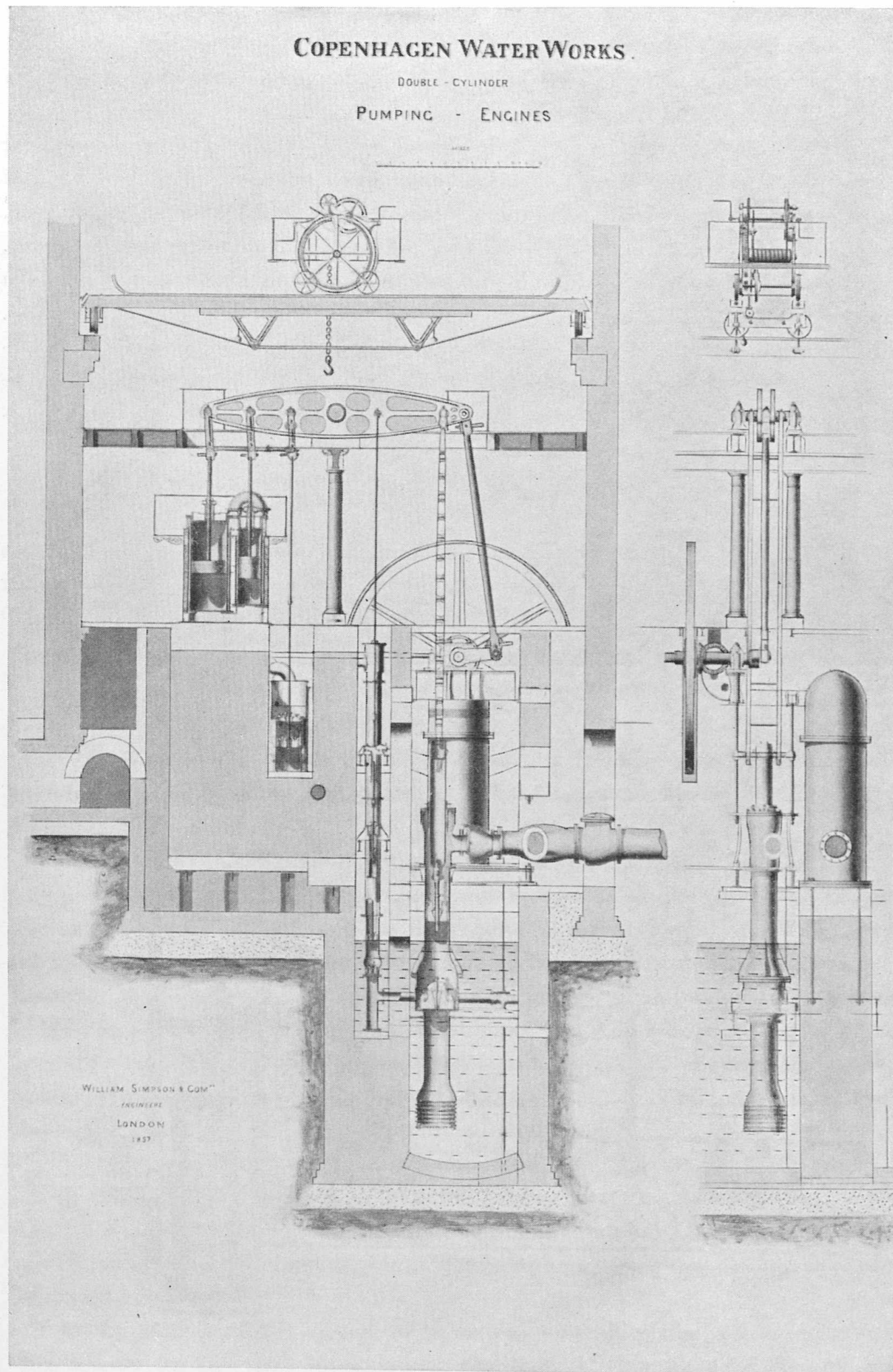
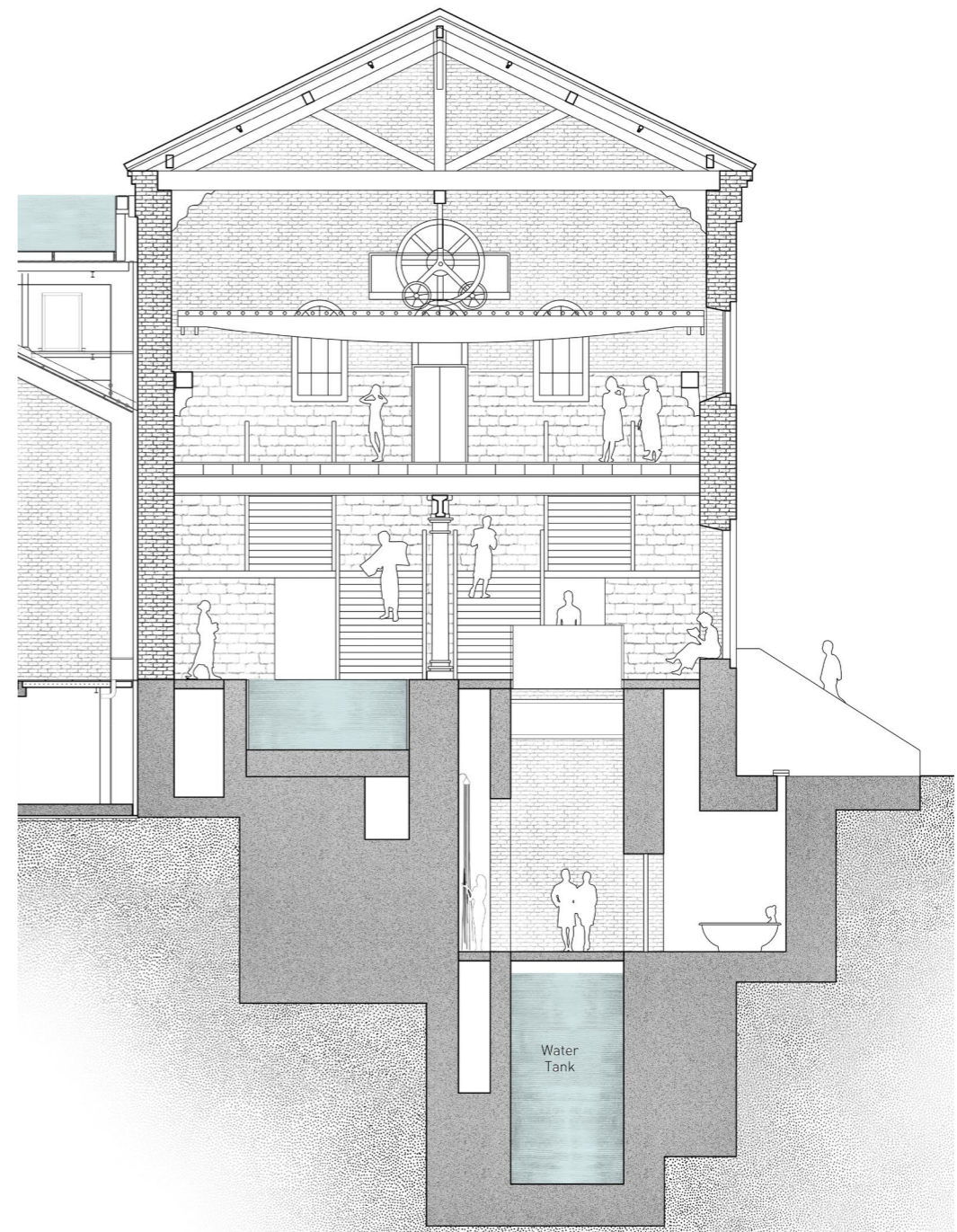
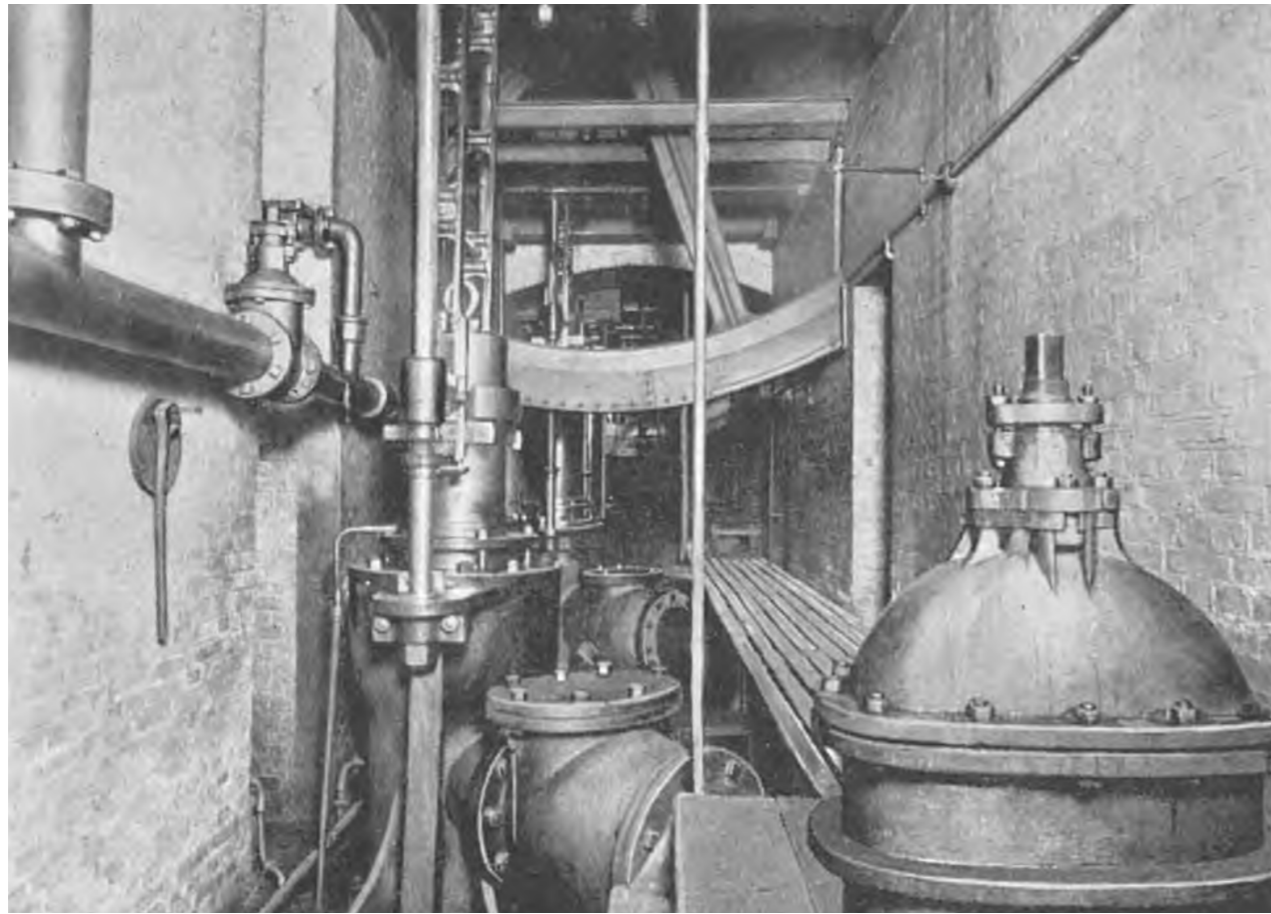

Fig. 60. Simpson's balancemaskine, efter originaltegningen.



Appropriation: A Variety of Bathing Experience
Pumphouse Cross Section 1:200



Underground of Pumpehuset, 1890



Underground of Pumpehuset, 2020

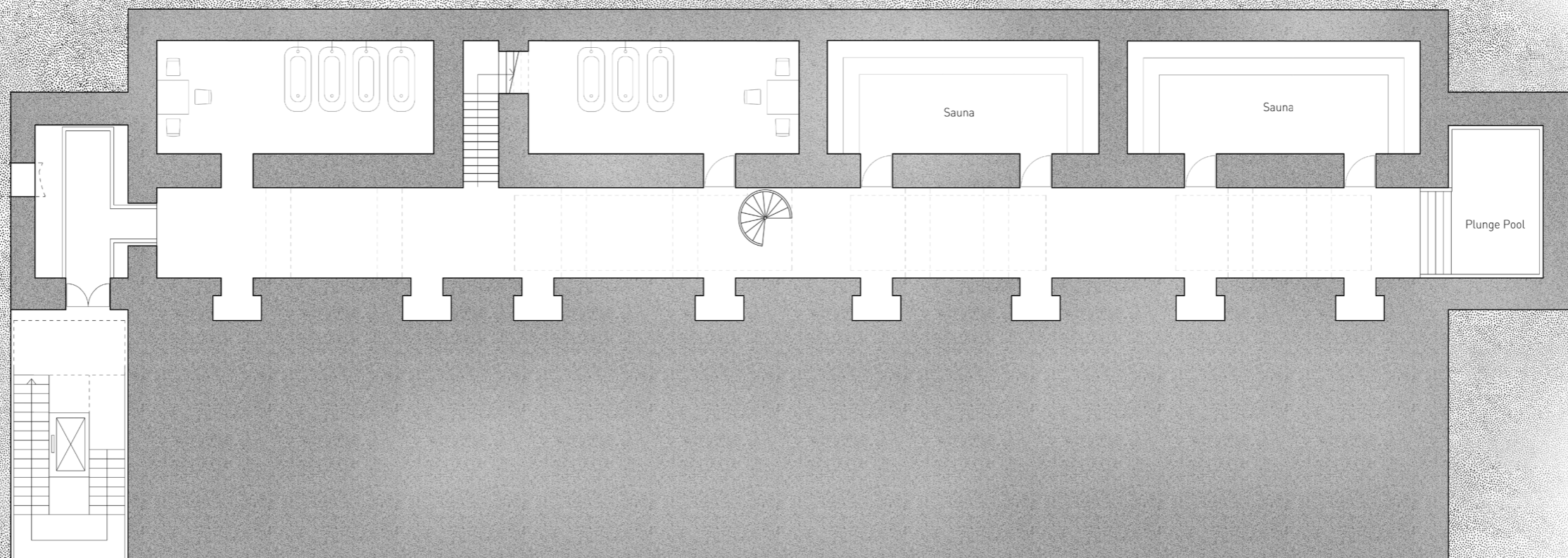

Pumpehuset Basement Plan

1:200

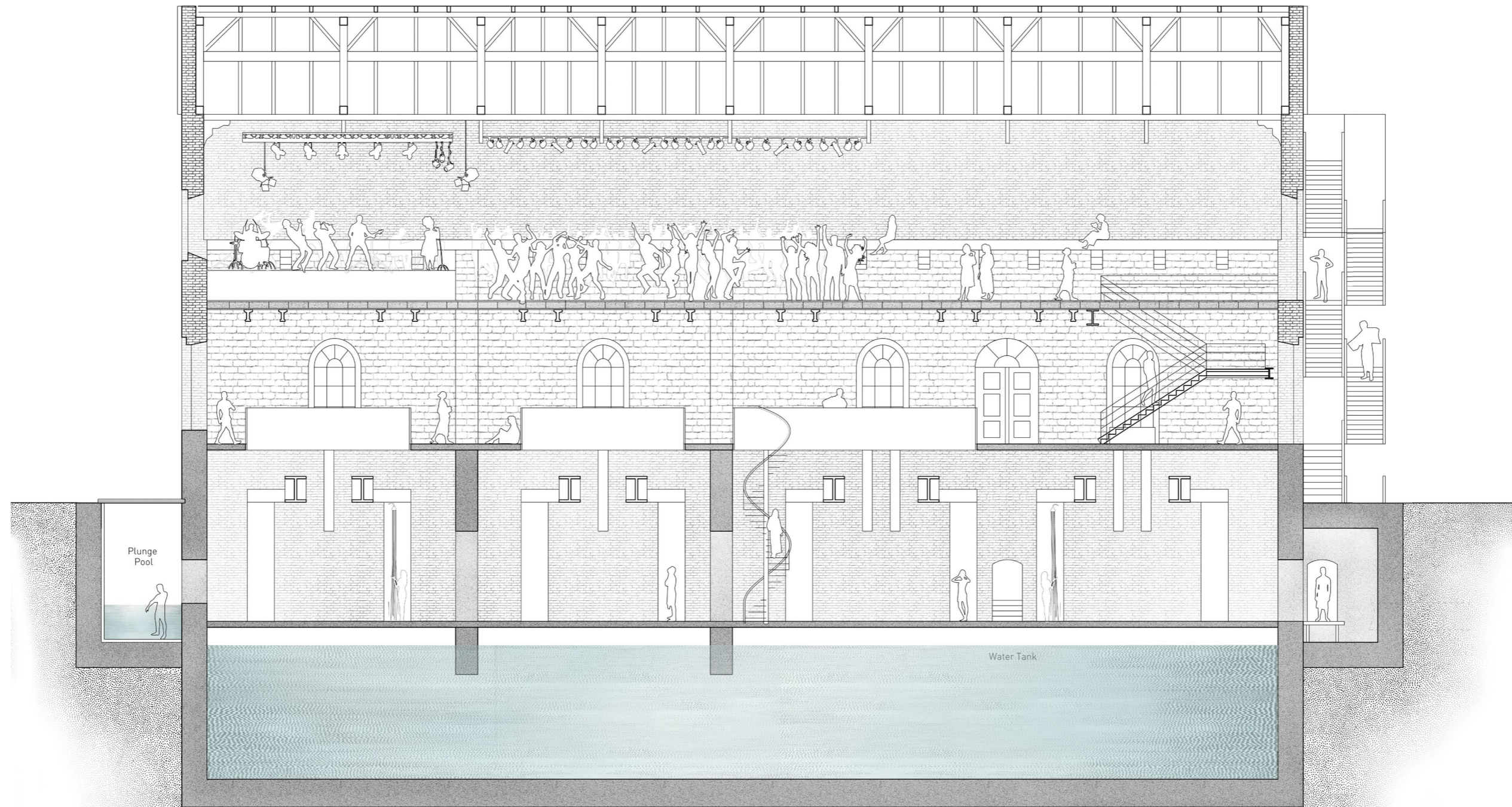

Longitudinal Section of Pumphouse

1:200

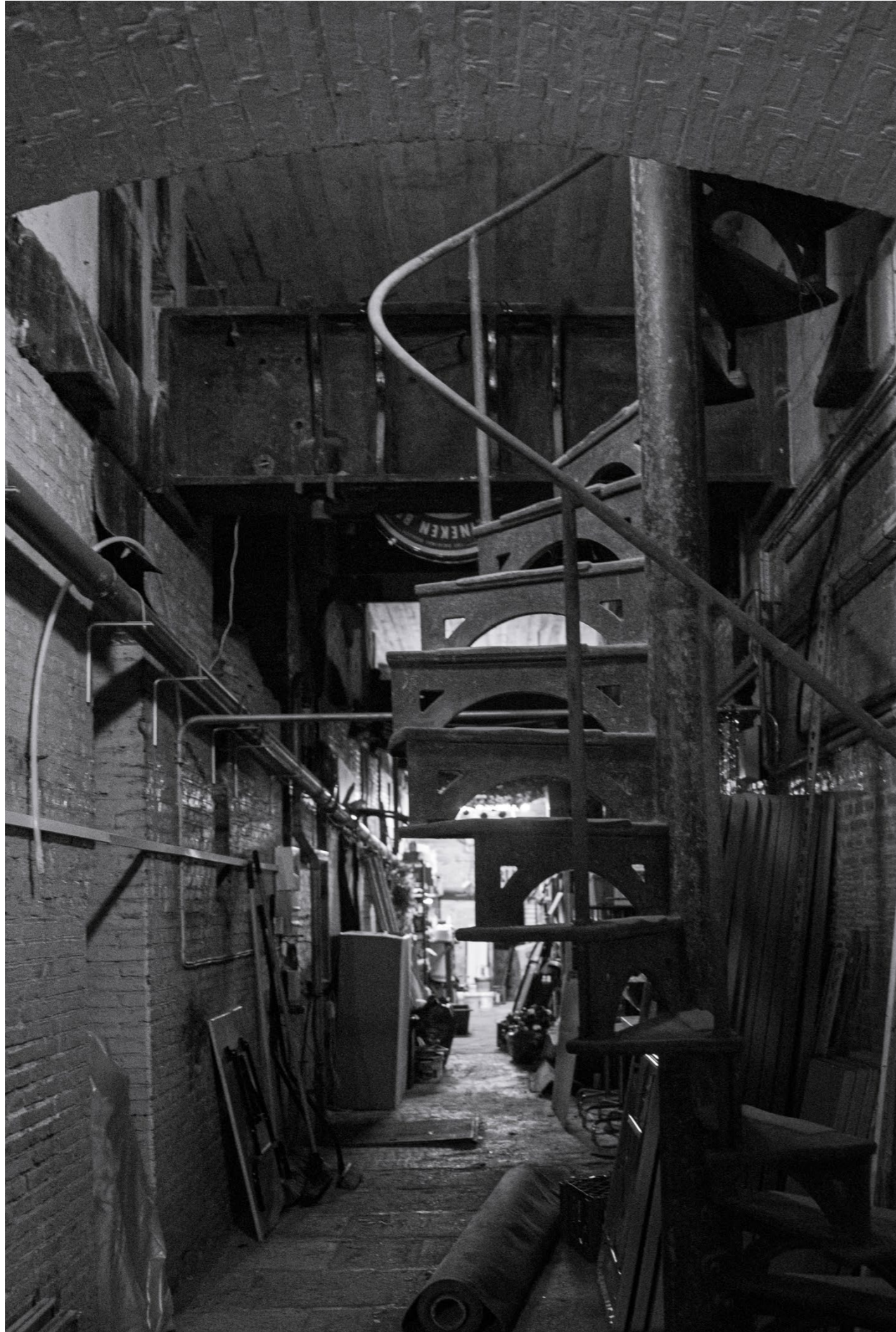

Underground of Pumpehuset, 2020

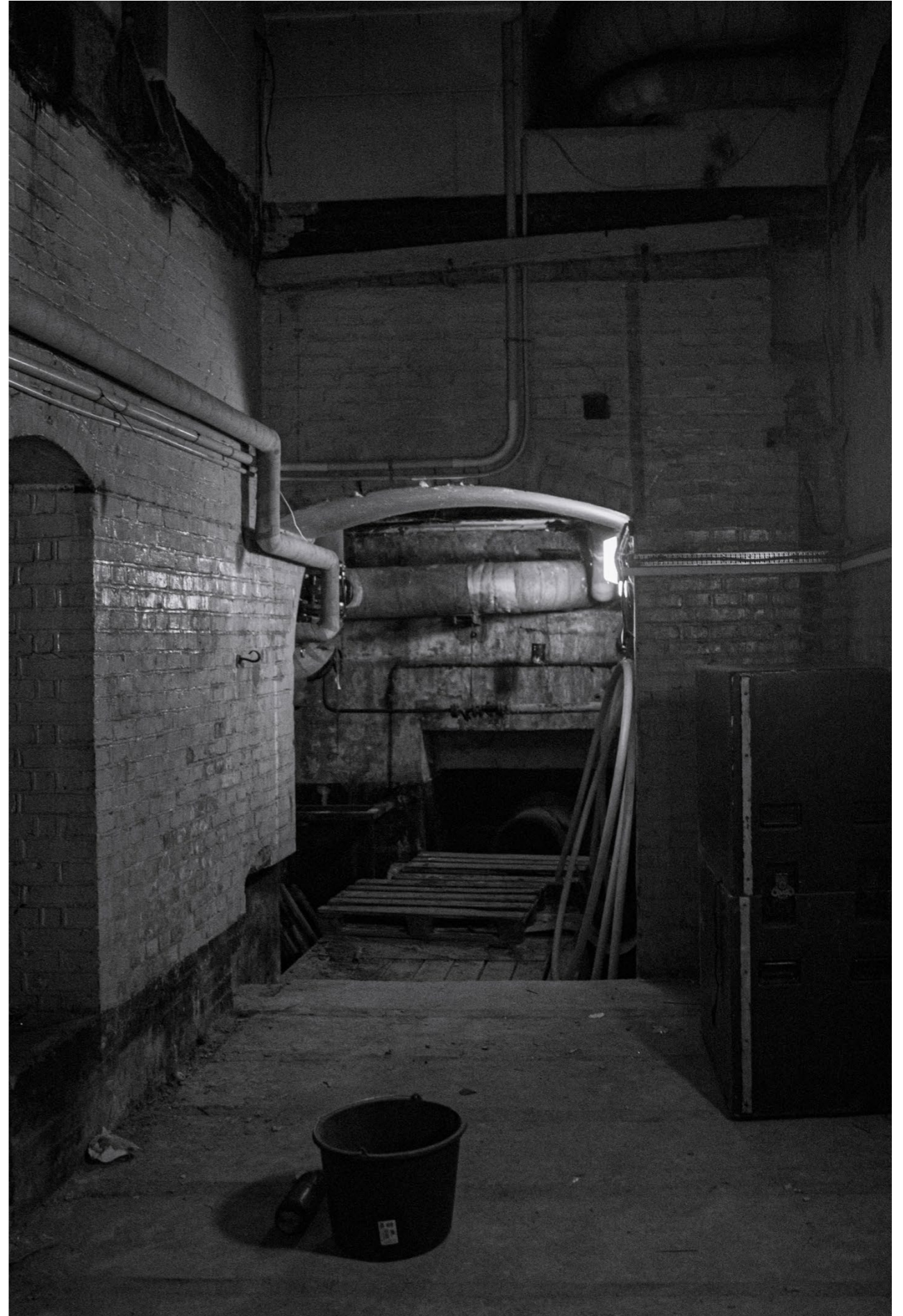

Underground of Pumpehuset, 2020



Reappropriation of the Shower Cell

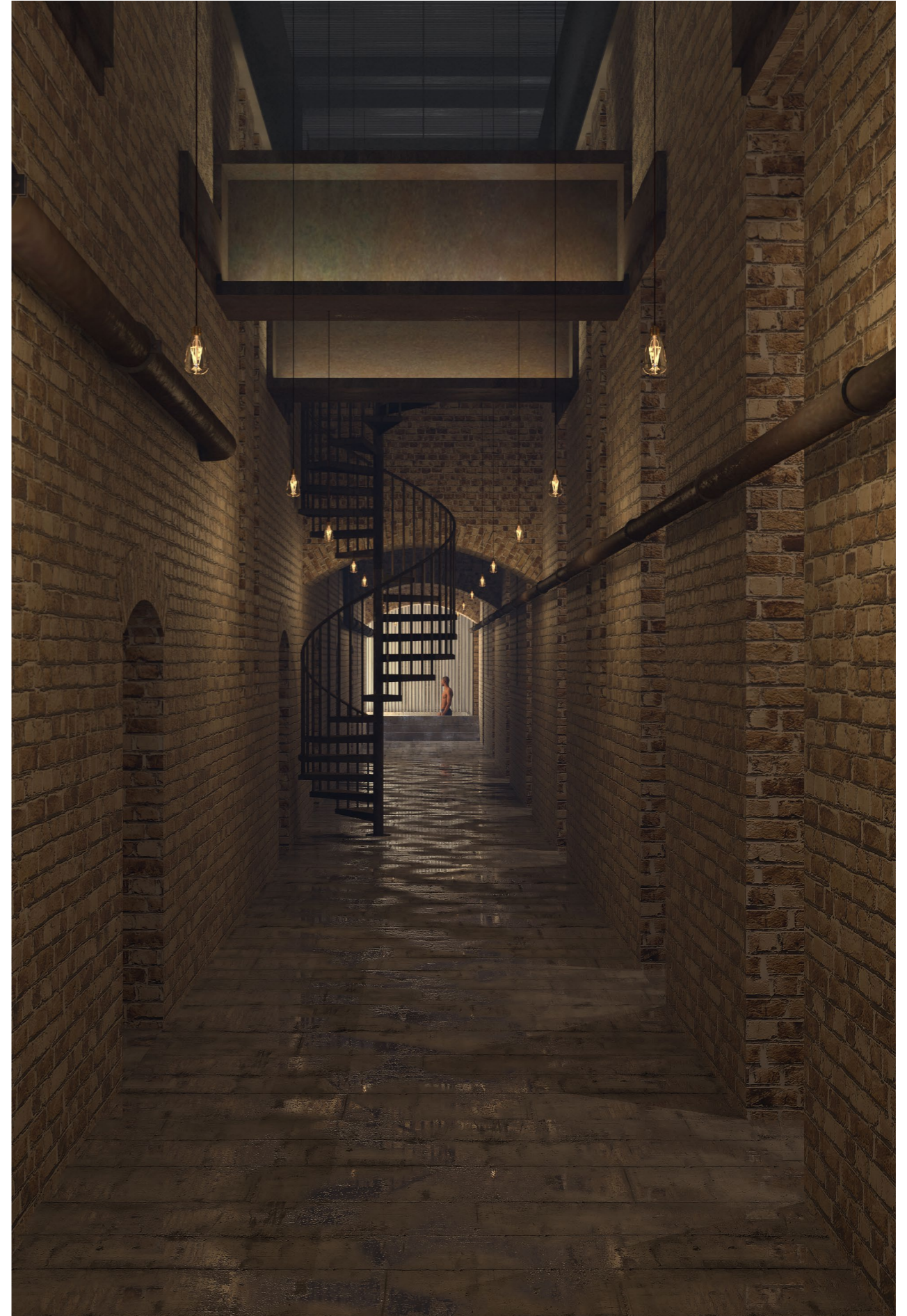

Reappropriation of Underground Corridor



Sjællandsgade Bad, 1922



Sjællandsgade Bad shower ,1922



Reappropriation of Bathhouse, 2014

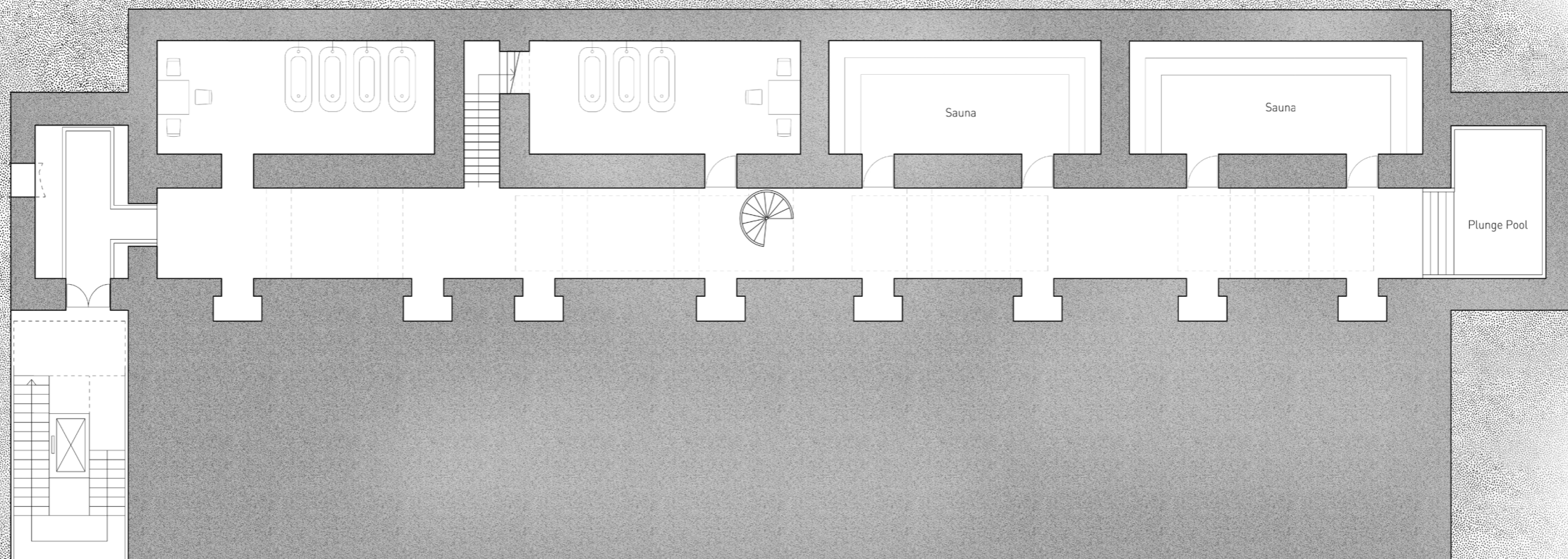

Pumphouse Basement Plan

1:200

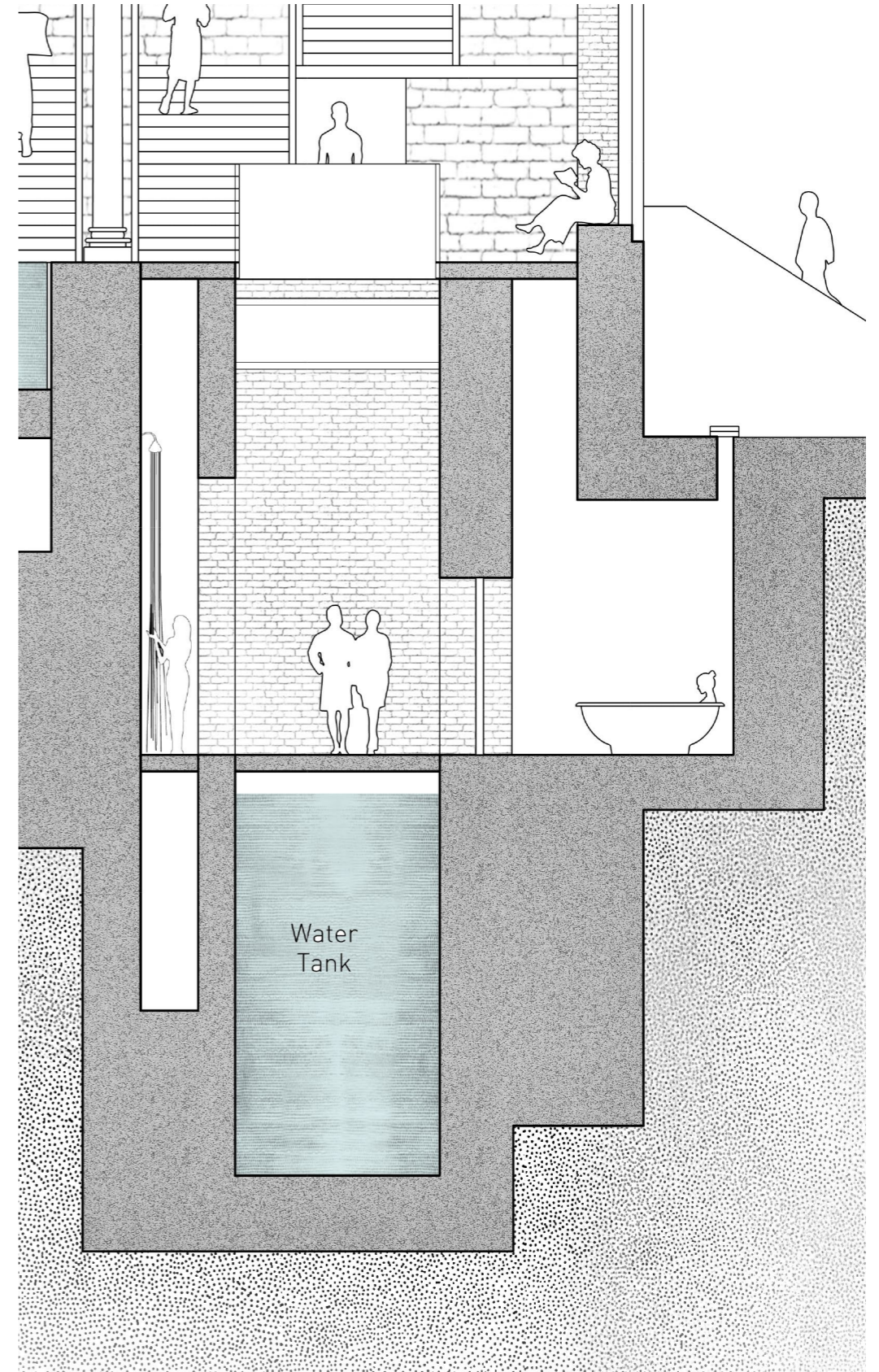

Appropriation: A Variety of Bathing Experience

Pumphouse Cross Section 1:150

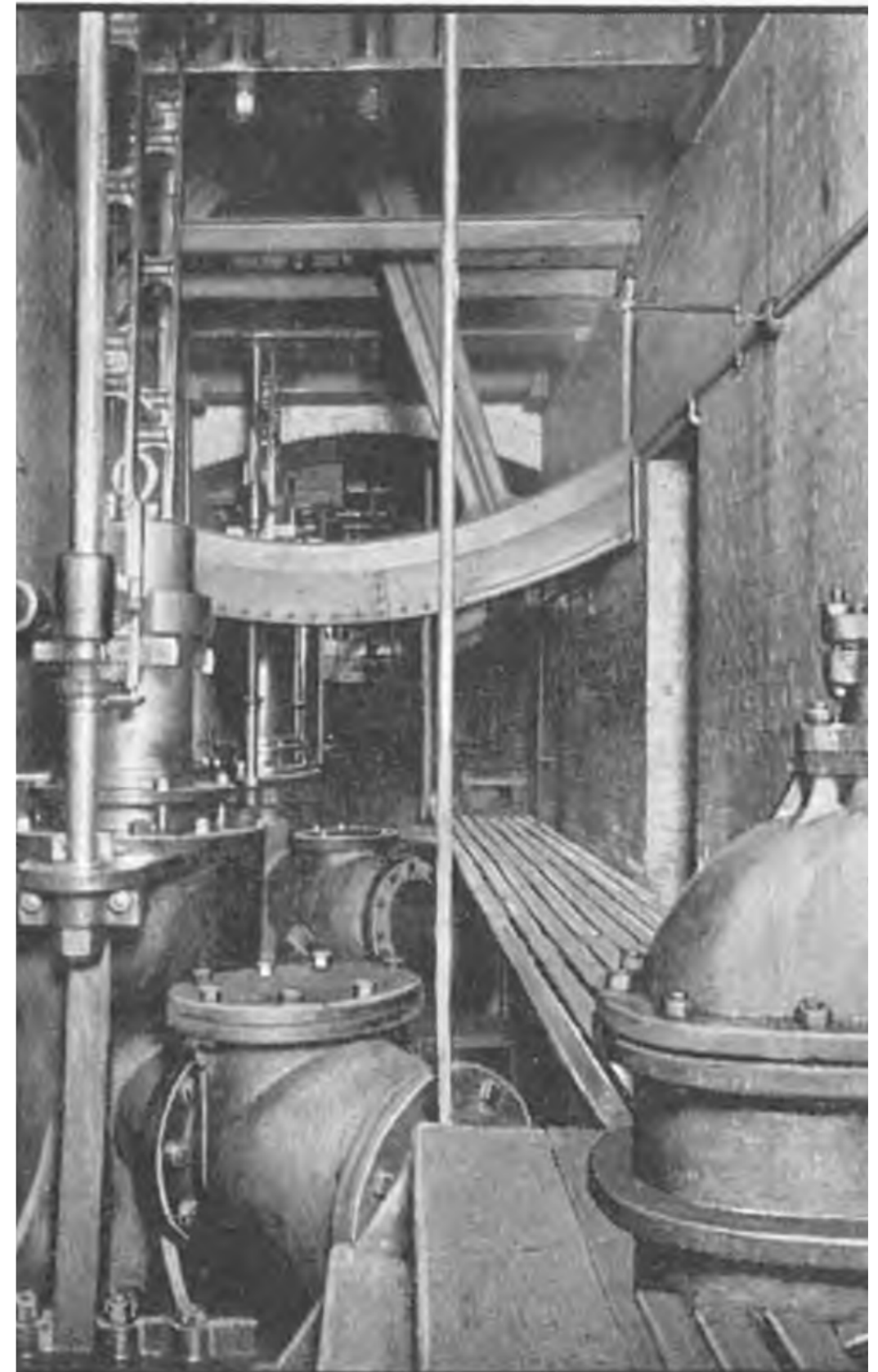

Underground of Pumpehuset, 1890

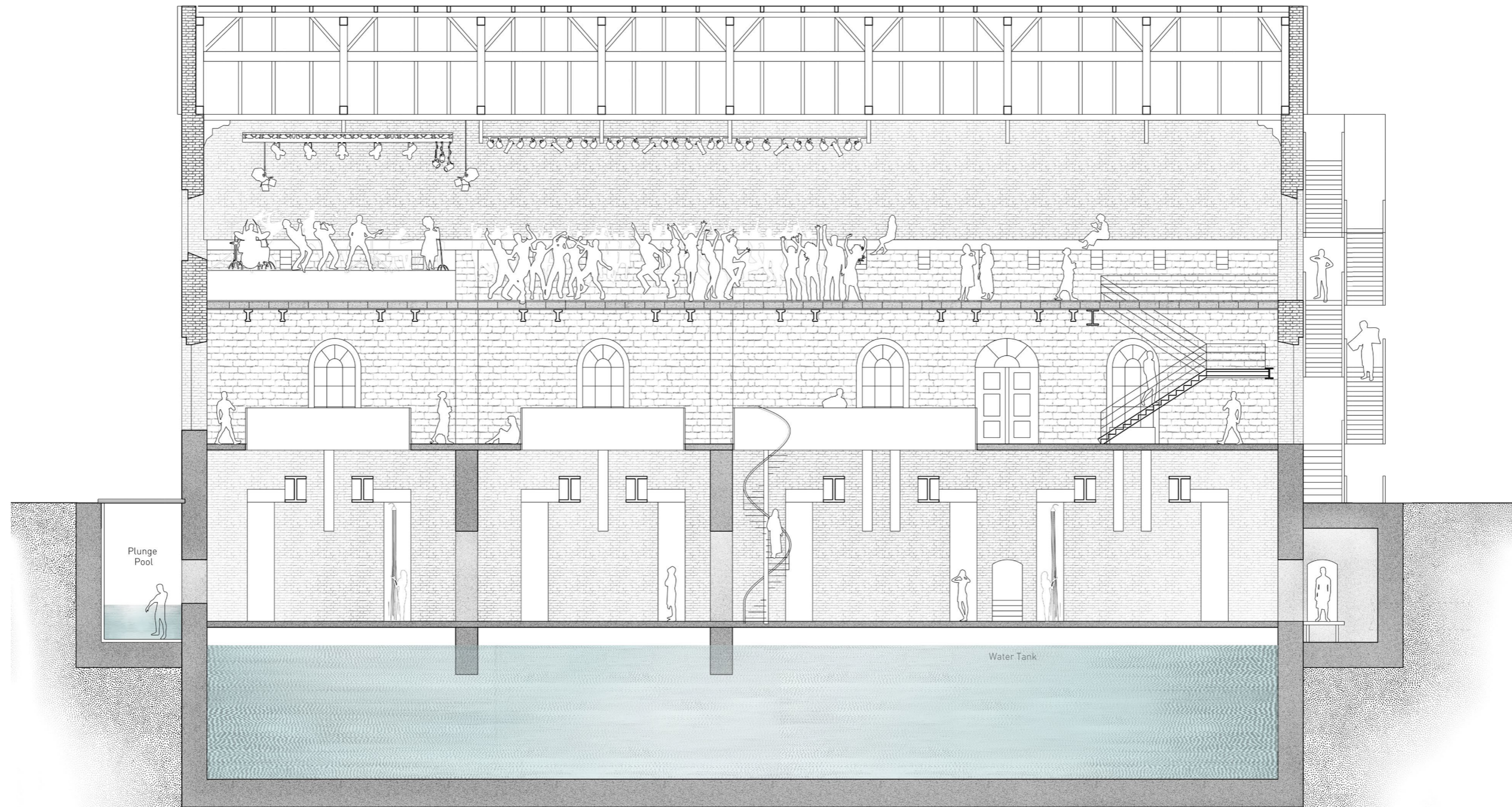

Longitudinal Section of Pumphouse

1:200



Interior of Pumpehuset First Floor

Access to Outdoor Stairs

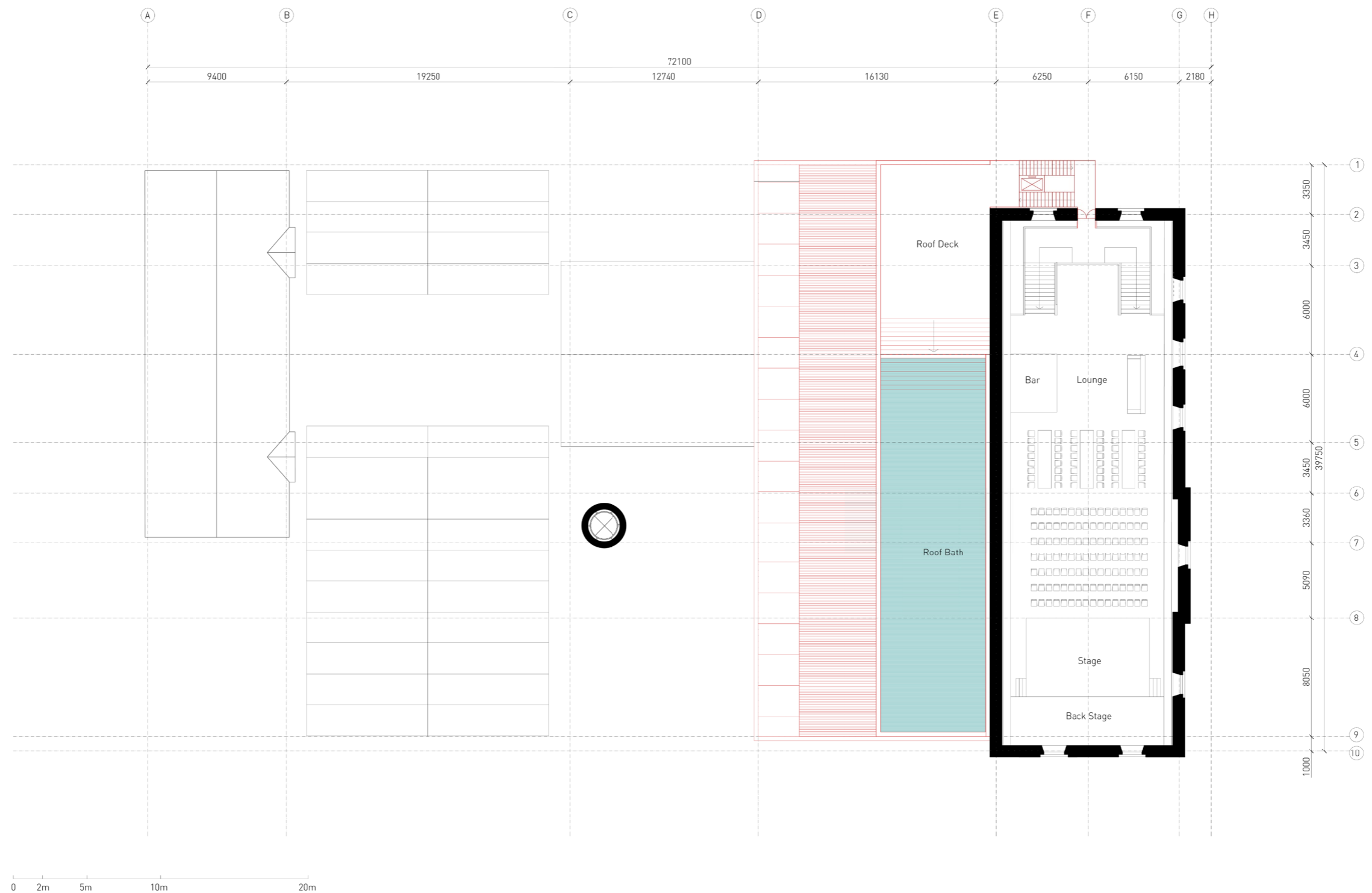

Plan of Roof Pool and First Floor of Pumphouse

1:300



The Roof Pool

An Intimate Contact to the Existing Building

A New Urban Spectacle

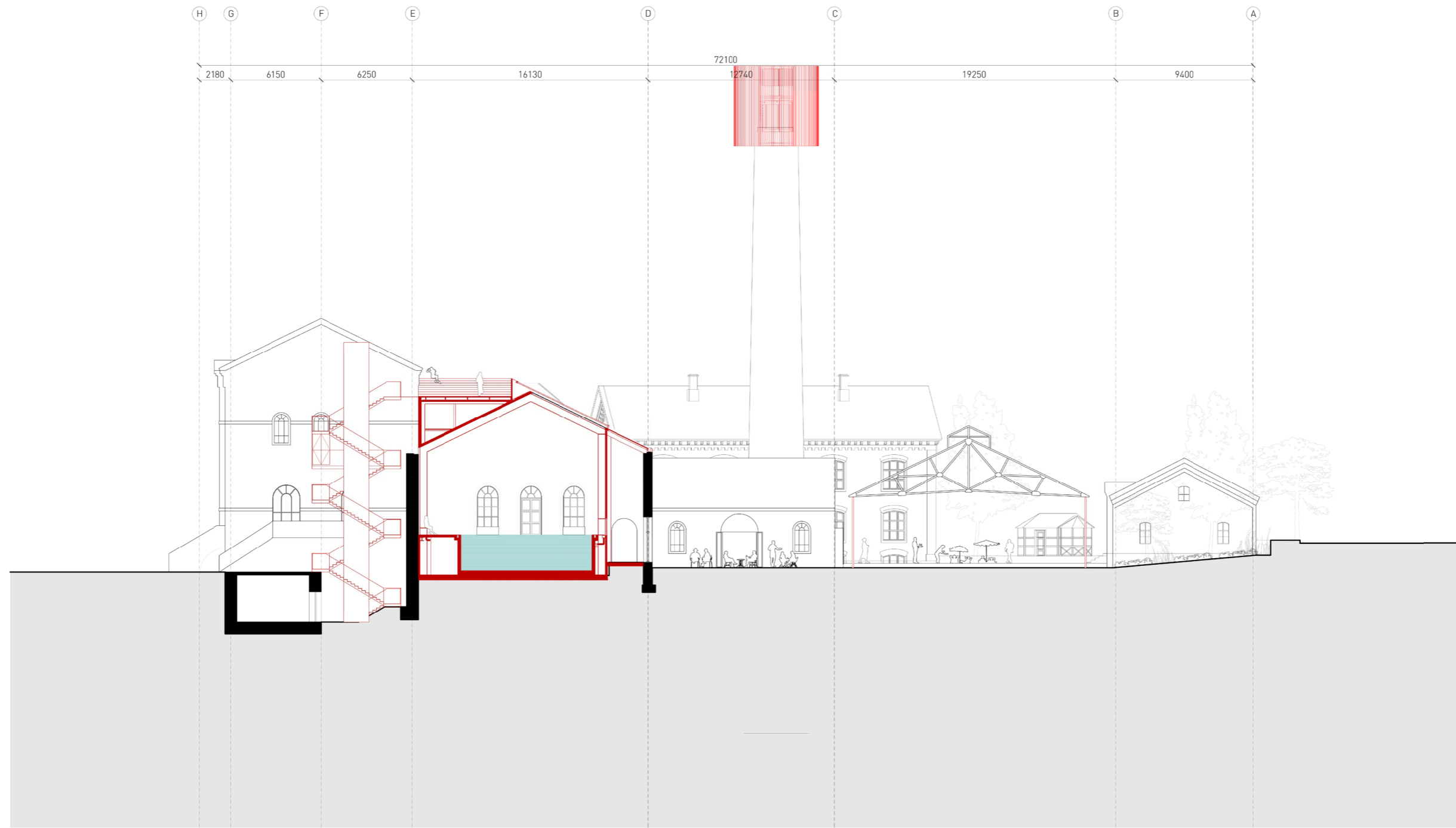

Site Section: Access to Roof Pool

1:300

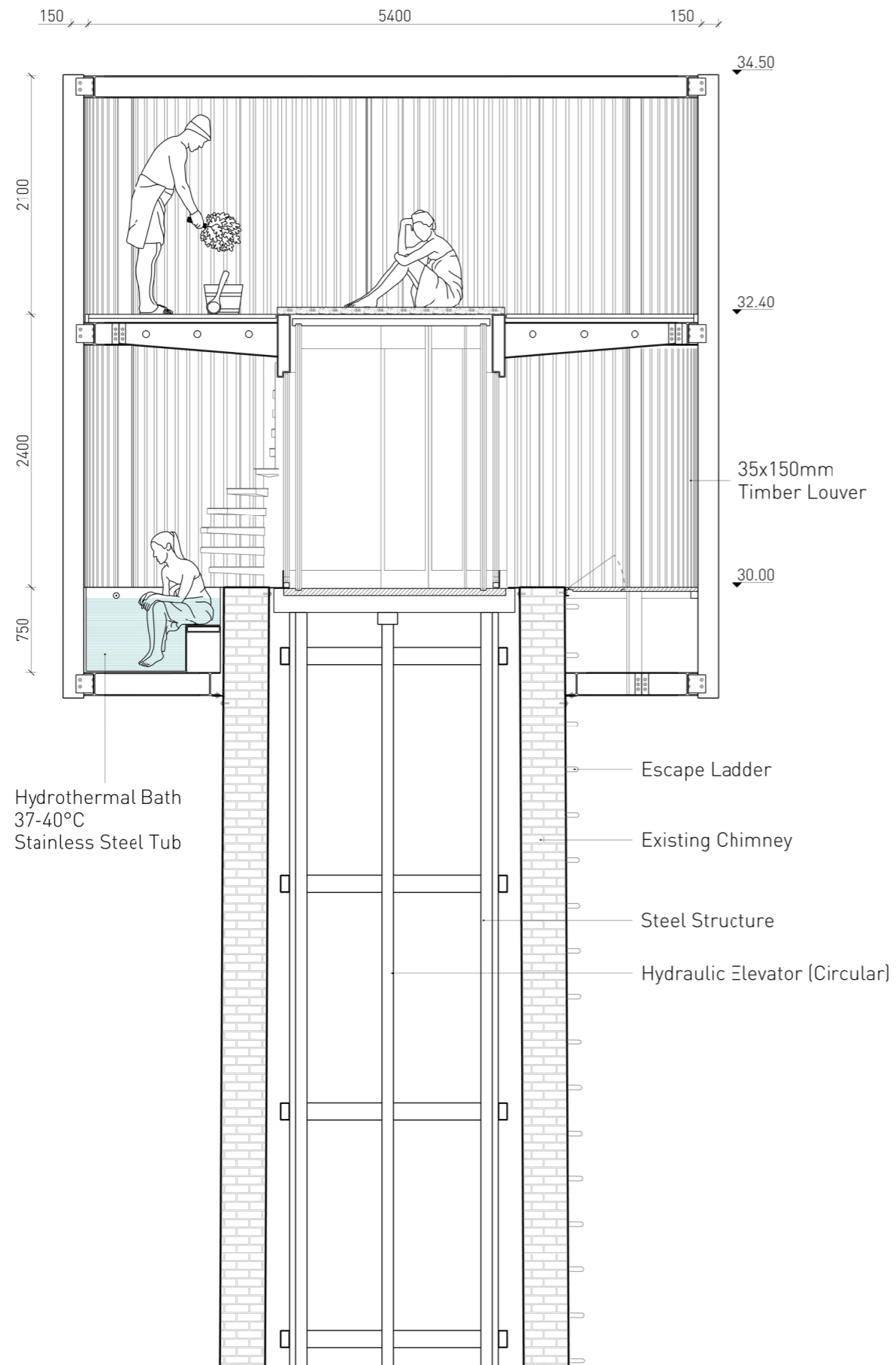

CHIMNEY BATH PLAN & SECTION
1:50



Celebration Moments
View from the Street

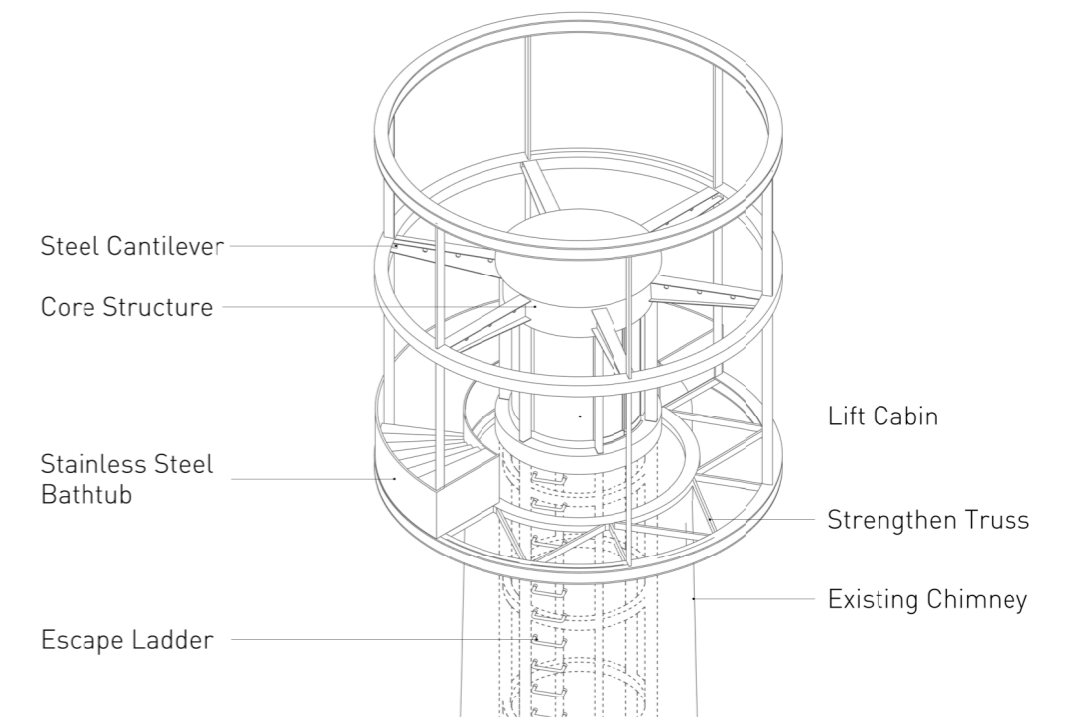
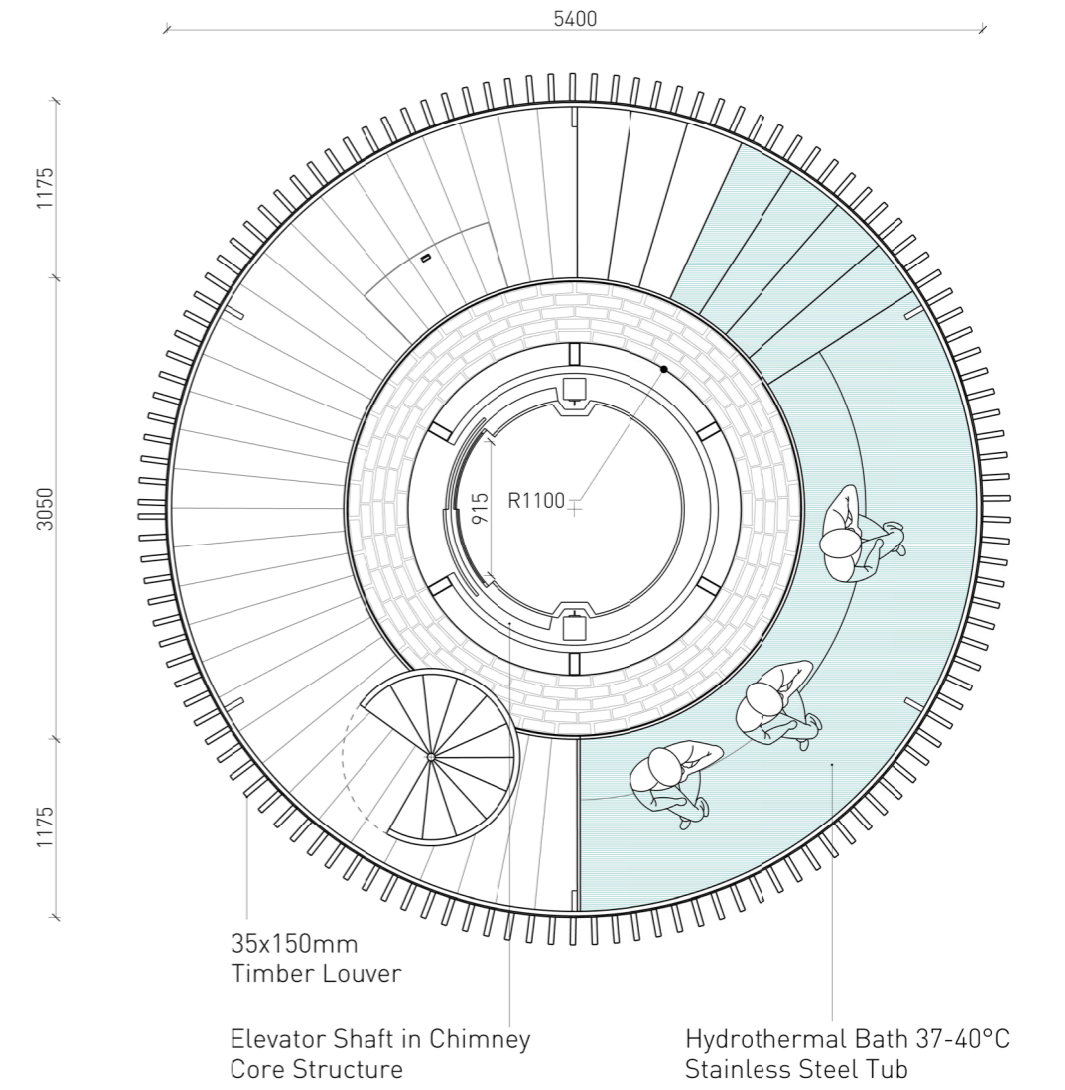

STRUCTURE AXONMATIC
1:100

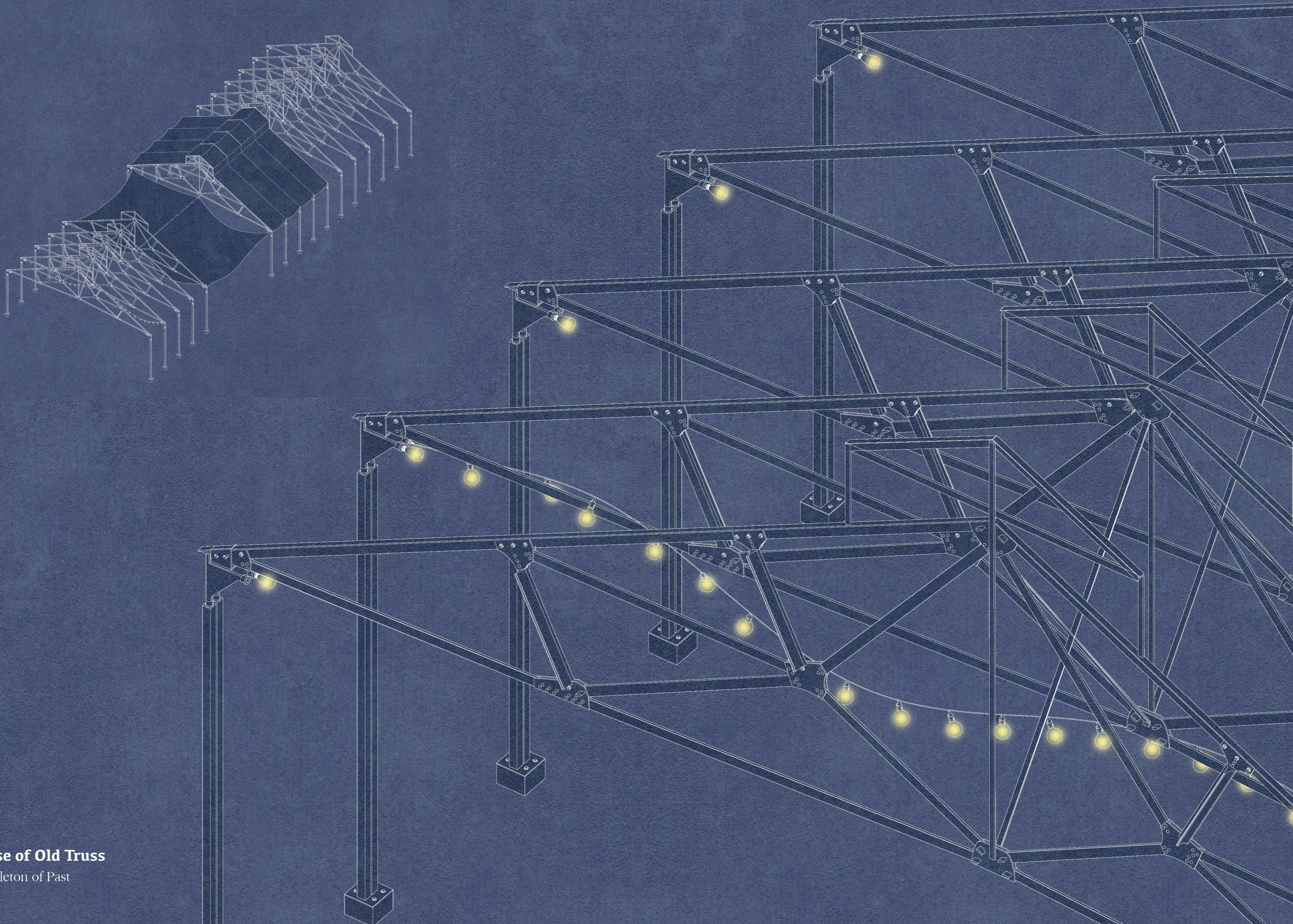

Reuse of Old Truss
A Skeleton of Past

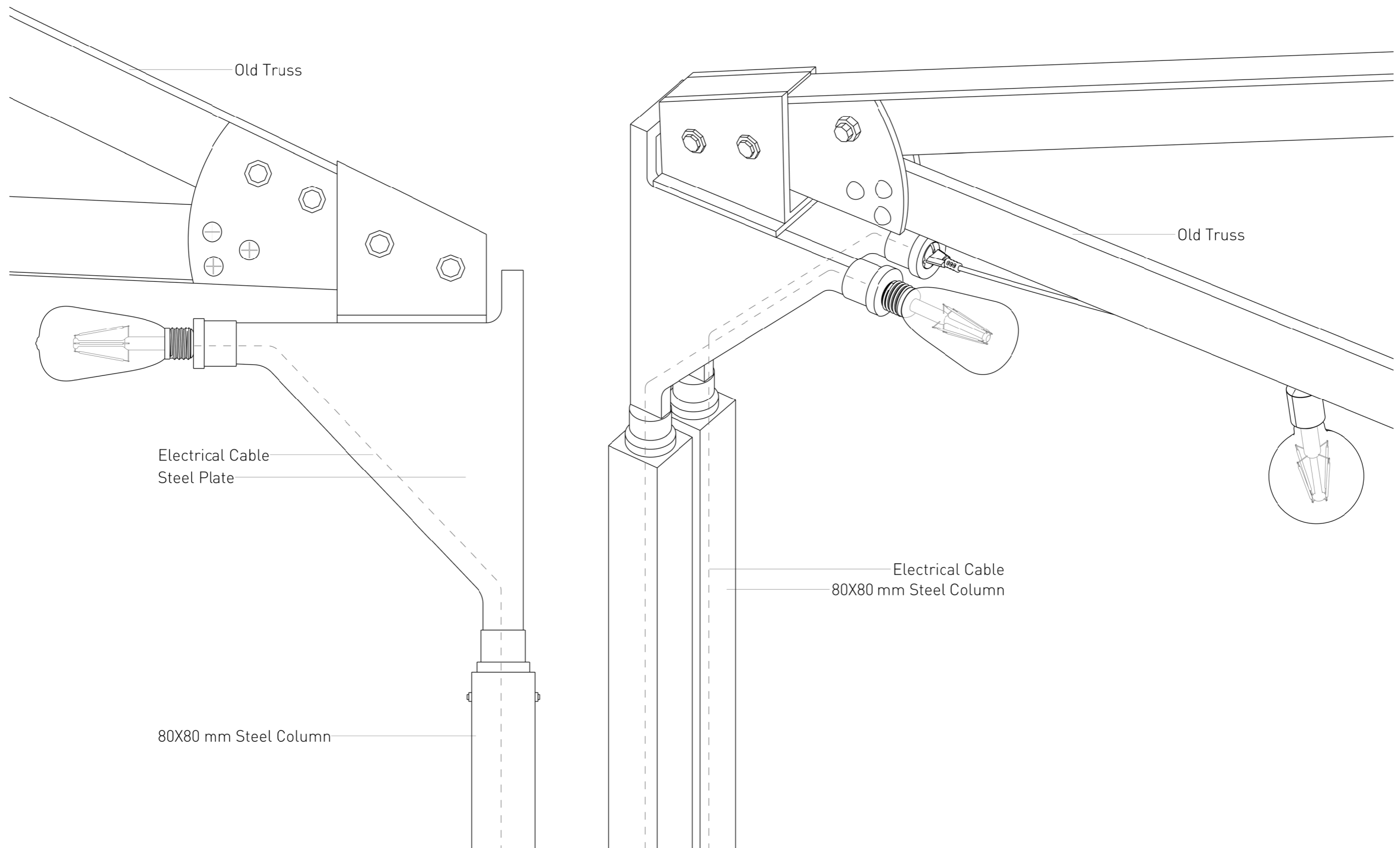

DETAIL: REUSE OF OLD TRUSS
1:5



The Frame of Old Roof Truss

View in the Square



Bathers Participating Urban Celebration

View from the Roof

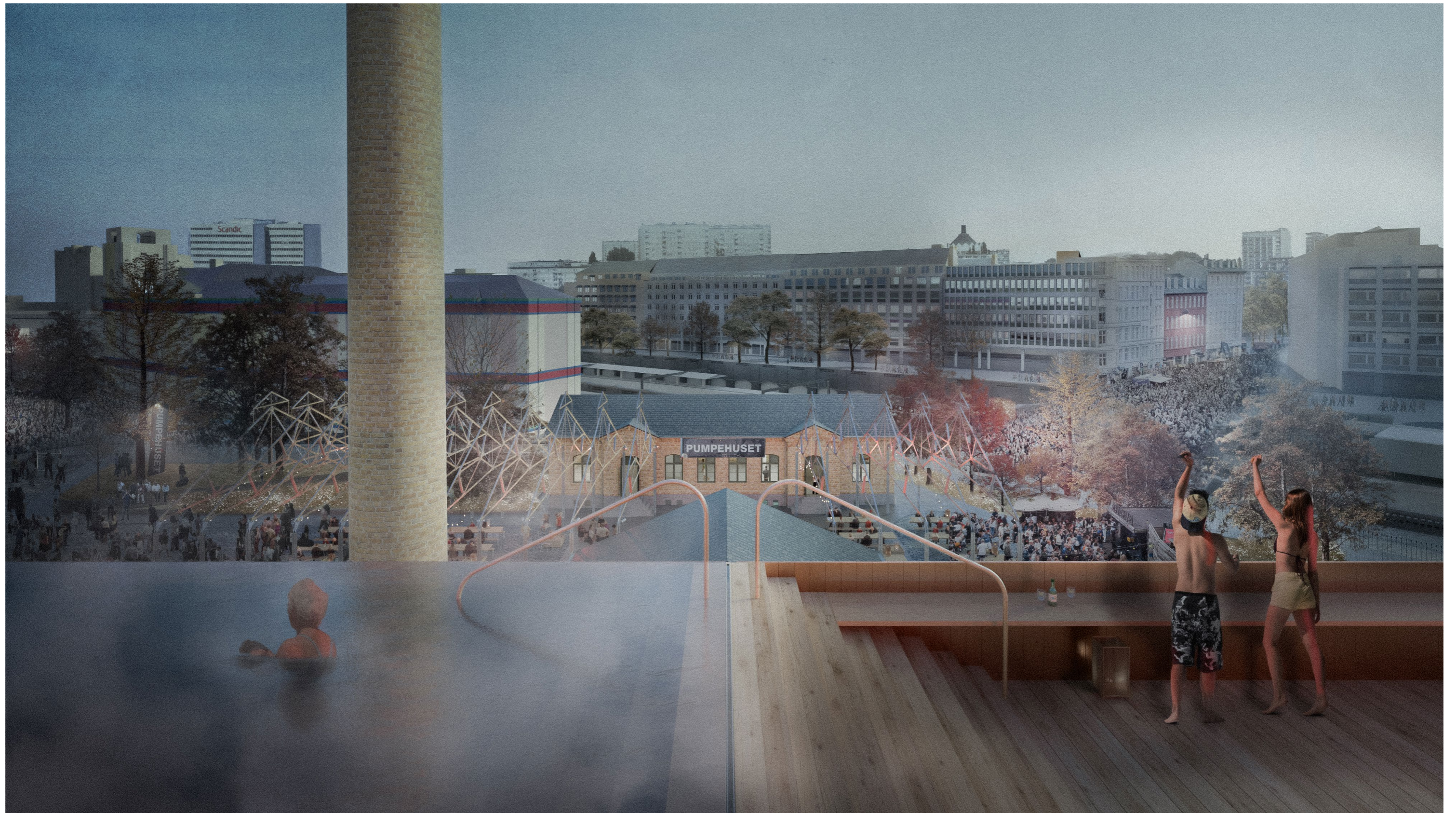

Bathers Participating Urban Celebration

View from the Roof



View From Cafe
the Old Truss and the New Roof Pool



The Design Book
The Independent Group, Interiors Buildings Cities, 2020 Spring
Danyu Zeng

Celebration as Revolution
An Urban Link of Distortion Street Event

Waterworks as Public Bath
A Combination of Cleansing and Celebration

Uncover the Past
Preserve the Historical Elements and Represent to Public