

## Underground Reservoir Identification Using Generalized Wellbore Data

Mansoori, Mehdi; Dankers, Arne; Van den Hof, Paul M J; Jansen, Jan Dirk; Rashtchian, Davood

**DOI**

[10.1016/j.ifacol.2015.12.144](https://doi.org/10.1016/j.ifacol.2015.12.144)

**Publication date**

2015

**Document Version**

Final published version

**Published in**

IFAC-PapersOnline

**Citation (APA)**

Mansoori, M., Dankers, A., Van den Hof, P. M. J., Jansen, J. D., & Rashtchian, D. (2015). Underground Reservoir Identification Using Generalized Wellbore Data. In *IFAC-PapersOnline* (Vol. 48, pp. 307-308). (IFAC-PapersOnline; Vol. 48, No. 28). Elsevier. <https://doi.org/10.1016/j.ifacol.2015.12.144>

**Important note**

To cite this publication, please use the final published version (if applicable). Please check the document version above.

**Copyright**

Other than for strictly personal use, it is not permitted to download, forward or distribute the text or part of it, without the consent of the author(s) and/or copyright holder(s), unless the work is under an open content license such as Creative Commons.

**Takedown policy**

Please contact us and provide details if you believe this document breaches copyrights. We will remove access to the work immediately and investigate your claim.

***Green Open Access added to TU Delft Institutional Repository***

***'You share, we take care!' – Taverne project***

**<https://www.openaccess.nl/en/you-share-we-take-care>**

Otherwise as indicated in the copyright section: the publisher is the copyright holder of this work and the author uses the Dutch legislation to make this work public.

# Underground Reservoir Identification Using Generalized Wellbore Data

Mehdi Mansoori\*, Arne Dankers\*\* and  
Paul M.J. Van den Hof\*\*\* Jan-Dirk Jansen\*\*\*\*  
Davood Rashtchian\*

\* *Chemical and Petroleum Eng. Dep., Sharif University of Technology,  
Iran(email: mmansoori@che.sharif.edu, rashtchian@sharif.edu)*

\*\* *Electrical Engineering, University of Calgary, Canada(email:  
adankers@hifieng.com)*

\*\*\* *Department of Electrical Engineering, Eindhoven University of  
Technology, The Netherlands (email: p.m.j.vandenhof@tue.nl)*

\*\*\*\* *Dept. of Geoscience and Engineering, Delft University of  
Technology, The Netherlands (email: j.d.jansen@tudelft.nl)*

**Abstract:** We present a novel method for estimating physical properties of an underground hydrocarbon reservoir, on the basis of generally measured wellbore flow rate and pressure signals at the bottom of a producing well. The method uses instrumental variable-based system identification techniques to solve for a closed-loop errors-in-variables problem. It is different from the conventional methods as it allows the instrumental variable signal to be correlated with the input and output signals' noise. This property increases the number of possible candidates to be used as the instrumental variable signal. The application of the proposed method has been investigated on a synthetic case study.

© 2015, IFAC (International Federation of Automatic Control) Hosting by Elsevier Ltd. All rights reserved.

*Keywords:* closed-loop identification, errors-in-variables, instrumental variables, well testing.

## 1. INTRODUCTION

*Well testing* or *pressure transient analysis* (PTA) is performed to estimate certain dynamical properties of an underground reservoir around a well such as the reservoir permeability and skin factor. In a conventional PTA the well is flowed at an almost constant-rate and then suddenly shut-in, i.e. made to flow at zero rate for a period of several days and the bottomhole pressure is recorded. Two common disadvantages of this operation are the loss of production and possible problems with well integrity due to the sudden pressure change effects.

Nowadays with the advent of permanent downhole gauges (PDG) it is possible to record bottomhole flow rate and pressure during normal production which gives an alternative well test data source. To extract reservoir information from the variable flow rate and pressure data, a deconvolution algorithm has to be implemented (Kamal and Abbaszadeh, 2009). These algorithms are very sensitive to sensor noise and much effort has been devoted to develop an effective deconvolution algorithm working on noisy data. Recently, Mansoori et al. (2015) have presented a system identification based method to perform PTA that rigorously accounts for the noise effects in the data including the sensor and process noise. This method requires an auxiliary signal in the form of a noise-free reference signal to remove the noise of the data. In this paper the limitation of having a noise-free signal is relaxed by using the recently

developed *errors-in-variables* (EIV) method presented in Dankers et al. (2014) which lets other noisy signals in the system to be used as the auxiliary signal. This method is also an IV based method, however unlike the method used in Mansoori et al. (2015), any signal that is measured in addition to the bottomhole pressure and flow rate can be used as the *instrumental variable*.

## 2. MODELING OF A RESERVOIR WITH A PRODUCING WELL

First we derive a block-diagram representation of the model of a production system with a vertical well connected to the center of a cylindrical reservoir. The wellhead choke system is manipulated to flow the well at a surface flow rate  $q_{wh}$  which results in the bottomhole flow rate  $q_{bh}$  and pressure  $p_{bh}$  respectively. The reservoir has been confined at the outer boundary with a constant-pressure aquifer while the top and bottom are represented with no-flow boundaries; for more details see Mansoori et al. (2015). This production system is considered as a two-component fluid delivery system where the components are the wellbore and the reservoir which are connected at the bottom of the well. We use a port-based modelling approach (Willems, 2007), where first each component is modeled separately, then they are bilaterally coupled to construct the entire production system model. Each component is modelled using four transfer functions with two inputs and two outputs. The graphical representation (block diagram representation) of such models for the production system have been plotted in Fig 1.

\* The work of Arne Dankers is supported in part by the National Science and Research Council (NSERC) of Canada and the work of Mehdi Mansoori is supported in part by Dana Energy Company.

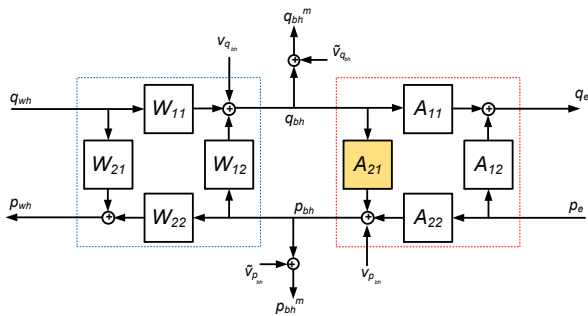

Fig. 1. The model of the entire production system after bilaterally coupling the models.

We will assume a constant zero-pressure boundary condition at the outer-edge of the reservoir (i.e.  $p_e = 0$ ), thus  $p_e$  and its effects can be removed from the model. This situation could happen when the reservoir is supported by a strong aquifer exerting constant pressure at its boundaries. Similarly, since we do not measure the pressure at the wellhead,  $p_{wh}$  can also be removed from the model. After simplification, in this model the only transfer function containing information about the reservoir is  $A_{21}$ . Thus the objective in the remainder of this paper is to identify  $A_{21}$  on the basis of measured signals  $q_{bh}^m$  and  $p_{bh}^m$ .

### 3. CLOSED-LOOP EIV SYSTEM IDENTIFICATION USING INSTRUMENTAL VARIABLES

From a system identification point of view, there are three key features of the measurement setup described above: 1)  $A_{21}$  is part of a closed-loop, 2) all variables are measured using sensors (i.e. sensor noise is present on both the input and output) and 3) it is possible to measure variables in addition to the input and output of  $A_{21}$  (such as bottom-hole temperature or additional pressure measurements). The result is a *closed-loop errors-in-variables* identification problem. In Dankers et al. (2014) an instrumental variable (IV) based method is presented which can be used in this situation.

From Fig. 1 the data generating system is:

$$p_{bh}(t) = A_{21}(q)q_{bh}(t) + v_{p_{bh}}(t) \quad (1)$$

where  $q^{-1}$  is the delay operator,  $p_{bh}$ ,  $q_{bh}$  and  $v_{p_{bh}}$  are the output, input and process noise respectively, and  $A_{21}$  is the transfer function to be identified. The process noise is modelled as stochastic process  $v_{p_{bh}}(t) = H^0(q)e(t)$ , where  $e$  is white noise. Both  $p_{bh}$ , and  $q_{bh}$  are measured with sensor noise:

$$p_{bh}^m(t) = p_{bh}(t) + \tilde{v}_{p_{bh}}(t), \quad q_{bh}^m(t) = q_{bh}(t) + \tilde{v}_{q_{bh}}(t) \quad (2)$$

where  $\tilde{v}_{p_{bh}}$  and  $\tilde{v}_{q_{bh}}$  are the sensor noises and modelled as stochastic processes with rational power spectral densities.

In the method of Dankers et al. (2014) an additional measurement (called an IV) is used to remove the sensor noise from the measurement of the input  $q_{bh}^m$ . Suppose that there is a measured signal,  $z$  available with the following properties: 1)  $z$  is correlated to the sensor noise free variable  $u$ , 2)  $z$  is not correlated to the sensor noise  $s_u$ , and  $s_y$ , and 3)  $\mathbb{E}[e(t)z(t)] = 0$ . When correlating the output and input with such an IV the sensor noise is “removed” from the relationship:

$$R_{p_{bh}^m z}(\tau) = A_{21}(q)R_{q_{bh}^m z}(\tau) + R_{\tilde{v}_{p_{bh}} z}(\tau) + R_{v_{p_{bh}} z}(\tau). \quad (3)$$

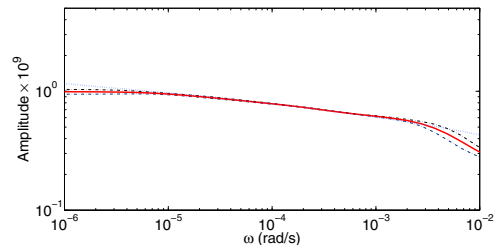

Fig. 2. The comparison of the amplitude of the frequency response plot of the identified model with the %99 confidence interval (dashed-line) and  $A_{21}$  with permeability = 196 mD (true value = 200 mD) and Skin factor = 0.06 (true value = 0) plotted in blue dotted-line.

where  $R_{xy}(\tau)$  is the cross-correlation between two signals  $x$  and  $y$ . The difference between (1) and (3) is that in (3), the “input”  $R_{uz}$  is known whereas in (1), only a noisy version of the input  $u$  is available. Consequently, (3) presents a classical closed-loop identification method can be used to obtain an estimate of  $A_{21}$  using  $R_{qz}$  as the ‘input’ and  $R_{pz}$  as the ‘output’. The main requirement of this method is that the input must be uncorrelated to the whitened noise at time  $t$ . Condition (3) above ensures that this requirement holds.

To estimate the physical parameters of the reservoir using the identified model, the frequency response of the identified model is compared with the frequency response of the analytical reservoir model derived.

### 4. SIMULATION STUDY

Simulation studies demonstrate that the method presented in this paper can be applied to data obtained from a well in practice. In the simulation study we generated data from a production system as described in Section 2 using the corresponding analytical expressions (Mansoori et al., 2015). In the example the data is used for performing the algorithm for the identification and then the identified model is used for physical parameter estimation. The estimated parameters, using the obtained frequency response of the identified model, have been plotted in Fig. 2.

### REFERENCES

- Dankers, A., Van den Hof, P.M.J., Bombois, X., and Heuberger, P.S. (2014). Errors in variables identification in dynamic networks by an instrumental variable approach. In *Proceedings of 19th IFAC World Congress*, pp. 2335-2340.
- Kamal, M.M. and Abbaszadeh, M. (2009). *Transient well testing*. Society of Petroleum Engineers.
- Mansoori, M., Van den Hof, P.M.J., Jansen, J.D., and Rashtchian, D. (2015). Pressure transient analysis of bottomhole pressure and flow rate measurements using system identification techniques. *Accepted for publication in SPE Journal*.
- Willems, J.C. (2007). The behavioral approach to open and interconnected systems. *IEEE Control Systems Magazine*, 27(6), 46–99.