

## Effective Naval Power Plant Design Space Exploration

de Vos, P.; de van der Schueren, T.A.R.; Los, S.; Visser, K.

**DOI**

[10.24868/10680](https://doi.org/10.24868/10680)

**Publication date**

2022

**Document Version**

Final published version

**Published in**

Proceedings of the International Naval Engineering Conference

**Citation (APA)**

de Vos, P., de van der Schueren, T. A. R., Los, S., & Visser, K. (2022). Effective Naval Power Plant Design Space Exploration. *Proceedings of the International Naval Engineering Conference*, 16, Article 67. <https://doi.org/10.24868/10680>

**Important note**

To cite this publication, please use the final published version (if applicable). Please check the document version above.

**Copyright**

Other than for strictly personal use, it is not permitted to download, forward or distribute the text or part of it, without the consent of the author(s) and/or copyright holder(s), unless the work is under an open content license such as Creative Commons.

**Takedown policy**

Please contact us and provide details if you believe this document breaches copyrights. We will remove access to the work immediately and investigate your claim.

# Effective Naval Power Plant Design Space Exploration

P. de Vos\* PhD CEng CMarEng MIMarEST, T. de van der Schueren MSc, S. Los MSc, K. Visser MSc RAdm.

\* *Delft University of Technology, NL*

\* Corresponding Author. Email: [p.devos@tudelft.nl](mailto:p.devos@tudelft.nl)

## Synopsis

In this paper a Concept Exploration Tool (CET) for naval ship power plants is presented. The ideas behind the CET are introduced as well as the inner workings of the tool. Objective functions for different relevant design criteria (energy efficiency, emissions, signatures, etc.) are shortly discussed, after which the results for a Frigate case study will be shown. Interesting solutions that are outside the well-known zone of conventional configurations, that may lead to new insights and innovative designs, are amongst the results of the CET; demonstrating the advantages of Design Space Exploration. The main development of this CET compared to earlier versions is however in the computational effectiveness of the tool, which is amongst others made possible by so-called Intermediate Design Algorithms (IDeAs). The major improvement in computational time provides additional room for further development of the objective functions used.

Keywords: Concept Exploration; Early-stage Design; Naval Power Plants (Power & Propulsion System).

## 1. Introduction: CETs – Computer-Aided Design in early design stages

Computer Aided Design (CAD) is a term often reserved for design activities that take place in extensive software packages during late design stages, e.g. the ‘detailed design’ stages in which building plans of ships are produced. Software that can support ship designers in early design stages is typically not covered by the term. Still, it is well known that during the early design stages the majority of decisions are made that to a large extent determine (and limit) the capabilities, costs and performance of new-build vessels, particularly so for naval ships and their systems. Although such early decisions, translating into first design requirements, have always been taken under uncertainty, the decisions are nowadays more uncertain than ever before. This increased uncertainty is caused by an increasing number of fuel and technology options together with additional design requirements stemming from environmental concerns. There is therefore a need for software that supports decision-making in these crucial early design stages.

Concept Exploration Tools (CETs), i.e. software that enables Design Space Exploration by automatically generating and evaluating large numbers of concept designs, are plentiful and could be put to use in this context. Given the increased dependency on software and computing power in early design stages, such an approach could be interpreted as Computer Aided Design as well. Since there is a very large number of concepts in the design space, a too large number for any human designer to oversee, both at the ship and at the system level, CETs can aid the designer in a first evaluation of the design space for requirements elucidation, resulting in more informed, or at least less biased, decision-making. However, it is difficult to assess which CETs are most successful and effective.

Principally, a CET should not be limited by a-priori constraints to enable full design space exploration, i.e. generate numerous concept design solutions. Furthermore, it is clear that these tools should contain good objective functions that capture a large number of different, potentially opposing design objectives sufficiently well to ensure proper evaluation and ranking of the generated concept designs. However, the level of detail of the generated designs is inherently limited, and thus so are the objective functions of the CET. The quality of the generated concept designs and implemented objective functions therefore determine to a large extent the successfulness of any CET.

With regards to effectiveness, given the large number of concept designs that need to be evaluated and ranked during design space exploration, computational time for evaluating the objective functions used in a CET is an important KPI of a CET as well. If it takes too long to evaluate the performance of e.g. a thousand concept designs, while the design space contains billions of possible design solutions, the CET will not be considered effective.

Despite the difficulties with successfulness and effectiveness, the generic nature of a CET may give rise to unusual design alternatives, less-biased solutions and more informed decision-making, which may prove a very relevant contribution to solving the early-stage design challenges and help avoid suboptimal design solutions. For these reasons, a CET for naval ship power plants, that builds upon earlier work of TU Delft and Nevesbu in this field, is presented in this paper. Interesting solutions that are outside the well-known zone of conventional configurations are amongst the results of the CET as well; demonstrating some of the advantages of Design Space

Exploration. The main development of this CET compared to earlier versions is however in the computational effectiveness of the tool. The major improvement in computational time provides additional room for further development of the objective functions used.

## 2. Design Space of Naval Power Plant Concept Exploration Tool

Design Space Exploration through Concept Generators (also known as Concept Exploration Tools) is not a new approach. The basic idea to utilise a computer’s processing power to automatically generate concept designs is central in many research and development initiatives, see e.g. (Pouw, 2007), (van Oers, 2011), (de Vos, 2018) and (Habben Jansen et al., 2020). Related research for other applications can be found in (Paparistodimou, 2018) and (Huisman, 2015). In the work presented in this article the fundamental idea is that ship designers and marine engineers can be supported during early-stage naval ship design as well, by having a ‘tool’ that generates concept designs for naval power plants. One could even argue that the existence of such tools enable new, earlier design stages than is the case in current design approaches, as current naval ship design methods start with setting up a list of requirements that are at least partly based on experience with already existing ships and thus biased. While such experience may help to quickly zoom in on a particular design solution and enable setting up realistic requirements and help to manage expectations, it can never be stated for certain that ‘the best solution’ was found, as not all solutions were considered and the number of design solutions considered in early-stage design are heavily constrained from the start of the design process. At the same time, one must be careful to state that it becomes possible to analyse all possible design solutions when using CETs and proclaiming unbiased exploration of the design space, as the design space is simply too large, also for current-day computers, to explore completely and thus bias is still needed to apply some a-priori constraints. The CET for naval power plants, developed by TU Delft and Nevesbu, is considered a good example of an effective CET.

Contrary to other CETs that have been developed in previous years (e.g. de Vos, 2018), the Naval Power Plant CET utilizes a pre-defined topology that dictates how power plant components are connected, see Figure 1. When the topology of energy distribution system is not pre-defined, the number of concept solutions in the design space truly is unimaginably large, as discussed in (de Vos, 2014). But even with a pre-defined topology, as shown in Figure 1, the number of design solution is near limitless, because of the many technological options and possible power ratings.

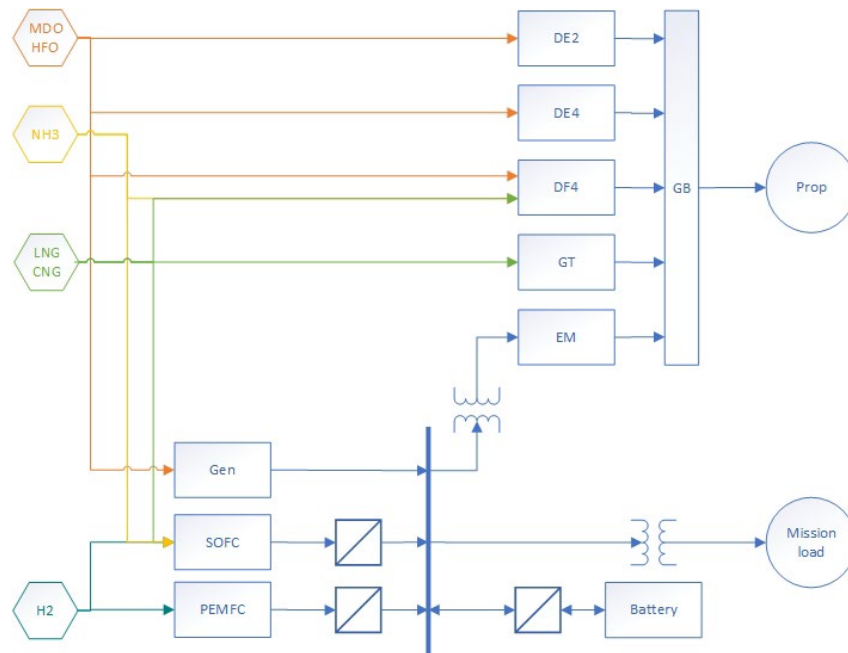

Figure 1: Pre-defined topology of potential naval power plants.

Note first of all that the pre-defined topology takes a number of different fuels into account. The naval power plant CET has been developed from an earlier CET that focussed on power and propulsion systems for commercial ships, see (van Dijk, 2018). Especially in commercial shipping, but to a lesser extent also in naval shipping, (future) marine fuels are heavily debated currently, because of shipping-induced harmful emissions and the need to go to net zero emissions. Furthermore, sustainable shipping fuels provide opportunities to switch to new technologies with lower infrared and acoustic signatures, making other fuels and technologies especially interesting for naval

applications. Therefore, the naval power plant CET is able to develop design solutions based on different fuels and different technology options like Fuel Cells, next to more conventional power conversion technologies like diesel engines, dual-fuel engines and gas turbines.

The fact that a fuel or component exists in the pre-defined topology does not necessarily mean that the component is present in each and every generated design solution. For instance, dual-fuel engines may be part of a generated configuration, but it may just as well not be because mechanical power is provided by e.g. diesel engines or electric motors. Furthermore, despite the pre-defined topology showing one component only per type of component, multiple components of one type may exist of different size and/or capacity in a configuration, e.g. a CODAD configuration with multiple 4-stroke diesel engines, potentially even containing a different number of cylinders or cylinders of different sizes per engine. A configuration consists of a unique set of main components of which many can be created with even a small number of options per component category. Table 1 shows the main components that can be present in generated naval power plant configurations.

Table 1: Potential main components of naval power plants generated & evaluated by the CET.

<b>Propellers</b>	<b>Main Propulsion Engines (MPE)</b>	<b>Electric Generation System (EGS)</b>	<b>Fuels</b>	<b>Others</b>
Fixed Pitch	2-stroke Diesel	Generator sets	MDO (F76)	Li-Ion batteries
Controllable Pitch	4-stroke Diesel	PEM Fuel Cell	HFO (LSFO)	Gearbox
	4-stroke Dual Fuel	Solid-Oxide Fuel Cell	LNG / CNG	
	Electric Motor		Ammonia	
	Gas Turbine		Hydrogen	

The number of shafts and the presence of gearboxes have a significant effect on the topology, as they allow the adoption of multiple propulsive engines. This significantly enlarges the design space, as every combination of engines is a unique configuration and thus a concept. Furthermore, it complicates the engine allocation, since the engines must be distributed between multiple shafts or gearboxes. In a multi-shaft configuration, the number and type of engines per shaft do not have to be equal either. Better yet, a combination of direct drive on one shaft and geared drive on the other is possible. This option is a result of the design philosophy behind CETs, in which constraints are kept to a minimum. It is hard to imagine that such configurations would actually be applied, but one has to allow for ‘strange answers’ in order to keep the possibility of being surprised by the CETs answers. In case of a direct drive, a single 2-stroke MPE is connected to the shaft. The possibility of a shaft motor/generator is not yet included in the current version of the CET.

Within one configuration, multiple identical components can be utilised as well. Moreover, multiple components from one category can occur within one configuration. For example, a twin-shaft hybrid configuration with two 4-stroke diesel engines (DE4) and two electric motors (EM) can exist. Theoretically, the number of components within a configuration is limitless, thus the number of concepts infinite. In practice, a limit per component can be set by the user of the tool. For a standard complete run, the number of components considered will likely lie between 40 and 45 components, resulting in roughly  $10^{12}$  to  $10^{13}$  different concepts in the design space. Most of these concepts are not feasible and will not be generated, as will be explained in section 3. Therefore, the actual design space will likely contain between 50.000 to 200.000 power plant concepts (which clearly is too large for any human design team to evaluate indeed).

### 3. Overview of Naval Power Plant Concept Exploration Tool

#### 3.1. Search method

The CET employs a modified brute force search algorithm to generate and evaluate all concepts. This means that all possible combinations are generated and evaluated to find optimal solutions. The choice for brute force is motivated by the fact that this algorithm offers exhaustive exploration of the design space and is relatively easy to understand, program and use. The algorithm is modified however, as generating every feasible and non-feasible concept would be computationally heavy, while not contributing to the successful exploration of the design space. Therefore, the choice is made to not generate all  $10^{13}$  possible configurations and filter out the unfeasible ones a-priori. Whether a configuration is deemed unfeasible, depends amongst others on the already selected components;

e.g. when a 2-stroke engine is selected, all configurations that contain a gearbox between the propeller and 2-stroke engine are a-priori removed from the design space.

Figure 2 shows an overview of the CET with generation of naval power plant configurations on the left-hand side and sub-models needed for evaluation and ranking of generated design solutions in the middle. This is where the objective functions determine the size, performance and robustness of generated configurations. After the input (component list, operational profile and client preferences) is given to the CET, a run of the model is started at the top left, following the arrows, to end at the bottom right of Figure 2. The generation model generates all possible concepts based on the components list that is inputted. All feasible configurations are saved in the concept library to be used by the rest of the tool. Since the concepts are saved, multiple runs of the evaluation tool can be performed, without the need to run the generation model again. The power management strategy block is important as it determines the required amount of installed power (for both propulsion and electric power generation) and controls how the different components will be utilized in the mission profile (e.g. range extension or power booster, etc.).

It must be noted that the actual amount of installed power is determined by the sizing sub-model, as the amount of installed power may be larger than strictly necessary, i.e. the power management strategy module determines the minimum amount of power that needs to be installed; the sizing module determines the actual amount of installed power, which may be considerably larger than the minimum. The sizing sub-model sizes all components both in terms of power and dimensions. Physical size of components is determined using first-principle dimension prediction tools as described in (Stapersma et al., 2015), taking the power rating as an input. The client preferences are used to determine the optimal amount of power per component. The actual installed power is communicated to the performance and robustness sub-models.

The performance sub-model simulates the mission, based on the operational profile that is defined in discrete time, i.e. a number of periods the ship is in a certain operational mode with a certain duration; see section 4 for examples. It calculates the fuel consumption, emissions and thermal signatures (see section 3.2) of all concepts. It can be seen that the performance sub-model also has an output towards the mission profile. This is a result of the operations of an electric propulsion motor, which adds a power demand to the electric mission profile. As a result, the performance of the MPEs is simulated first, after which all electric components are designed and simulated. Subsequently, the robustness sub-model computes the robustness of the configurations; see section 3.2. Lastly, all results are processed in the multi criteria analysis sub-model, which produces a ranking of all concepts and a visualisation of the design space. Pseudo-code for the calculation procedure of the naval power plant CET is given in appendix I.

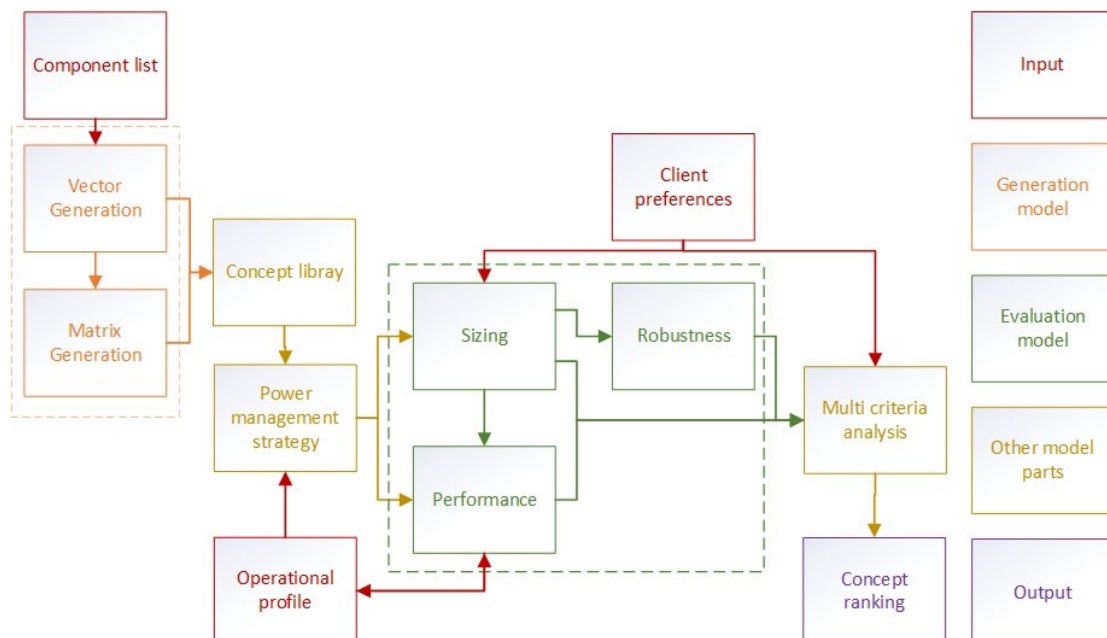

Figure 2: Overview of the naval power plant CET; within the dashed lines the main sub-models needed for evaluation of generated concepts can be found. A legend is provided on the right-hand side.

A critical note must be added with regards to the earlier mentioned brute force search method that is employed by the naval power plant CET. Intermediate design choices are resolved during concept generation, rather than generating all alternative concepts. During the design process, multiple design options are available on component level. Every option could be seen as a unique concept in and of itself, which would result in a vast expansion of the number of concepts in the design space. To guarantee a manageable computational time, Intermediate Design Algorithms (IDeAs) are used. This concept was developed by (van Dijk, 2018) to limit the number of concepts within the CET. An IDeA designs every feasible option for a component and makes a first estimation of the performance of that component. The optimal design is chosen based on the client preferences, which explains the input of client preference into the sizing sub-model in Figure 2.

Figure 3 shows the working principles of the IDeAs and how it stops the growth of concepts. In situation A, every design option is developed into its own concept. With two options per type the situation stays relatively simple. However, in reality, there are often between 10 to 30 options per MPE or EGS component. This would result in a growth from 100.000 configurations in the design space to roughly 1 to 10 billion concepts, depending on the employed components and freedom given to the CET. It is deemed impractical to evaluate all these concepts, even for a computer. Situation B shows a solution, by applying the IDeAs. It is noted that the use of the IDeAs goes against the design philosophy of the CET, as it essentially adds constraints and thus limits the design space. However, the increase in CET effectiveness is considered more important as full exploration; i.e. the design space would not be explorable in an acceptable time frame without these IDeAs.

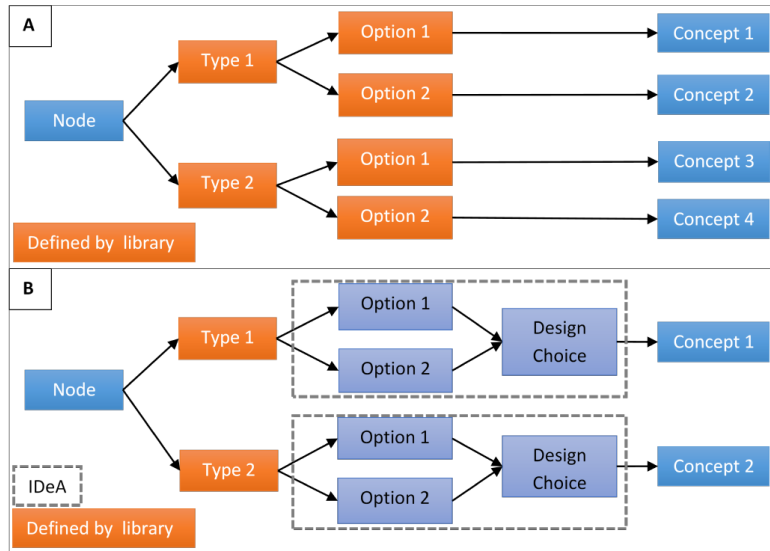

Figure 3: Working principle of IDeA (Intermediate Design Algorithm), resulting in a limitation of concepts.

### 3.2. Objective functions

The objective functions (quantified design criteria) used in the naval power plant CET are:

1. 'total efficiency', defined as the ratio between total delivered useful energy to complete the pre-defined mission profile (both electric and propulsion power, multiplied with the relevant duration) and used energy in terms of fuel consumption times lower heating value of the selected fuel,
2. mass of the total power plant,
3. volume requirements for the power plant concept (Stapersma et al., 2015),
4. harmful emissions,
5. 'signatures' and
6. 'robustness'.

Although all design criteria have inherent uncertainty when quantified, the latter two are the most difficult to quantify and the most specific to naval applications. The definitions used are:

Thermal signature:

$$\dot{Q}_{avg} = \frac{\sum_{i=1}^N \dot{Q}_i \cdot t_i}{t_{total}}$$

with

$$\dot{Q}_i = \dot{m}_i \cdot c_p \cdot (T_{i,exh} - T_{i,amb})$$

and Robustness:

$$R = \frac{P_{hurt}}{P_{nom}}$$

For the thermal signature it is clear that this is a weighted average of the exhaust gas flow and its temperature. It could be argued that temperature alone is a sufficient indication of thermal signature, but by including the mass flow a better distinction can be made between the different power conversion technologies. Furthermore, it provides a motivation for the CET to not increase the installed power too much, as this will enlarge the thermal signature according to the definition above. The latter point is counteracting the robustness objective function, because this one will strive for more installed power to have sufficient margin between installed power and nominal power such that even in a ‘hurt’ state full functionality remains (see equation). The hurt state is here considered to be the electric power or mechanical power that can still be delivered after a failure of either propeller/shaft/gearbox (the one with the largest power rating will be chosen to fail), or a main engine or an electricity generation system.

## 4. Case Studies

### 4.1. Frigate - Input

The CET has been used to explore the design space for power plants of a frigate. In case study 1A, Fuel Cells are an option for the EGS, in case study 1B Fuel Cells have been taken out as potential power conversion technology. The pre-determined operational profile is depicted in Figure 4. Table 2 provides the power per mission element of the operational profile for further clarification of the operational profile.

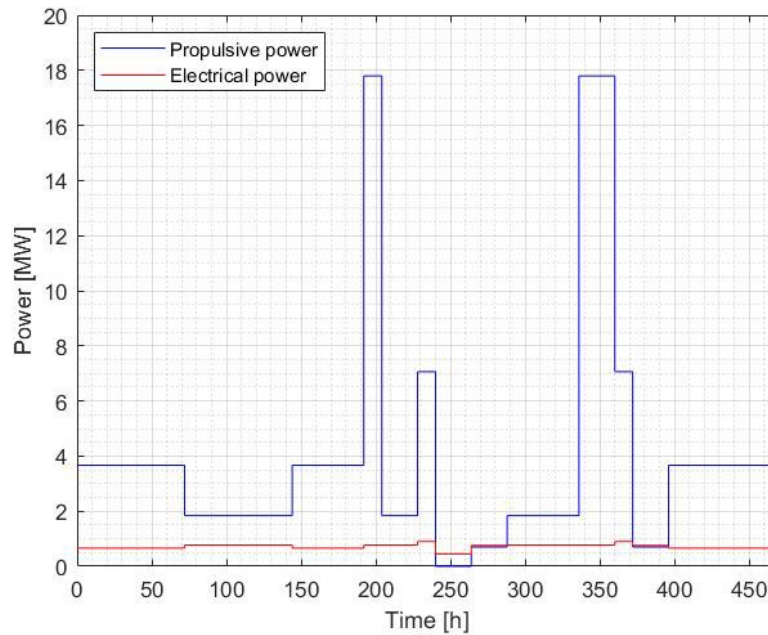

Figure 4: Operational profile of case study Frigate 1A and 1B.

Table 2: Mission elements of operational profile depicted in Figure 4. T = Transit (18 knots), P = Patrol (14 knots), F = Full speed (27 knots), C = Combat, A = Anchor, L = Low speed (10 knots).

Mode	T	P	T	F	P	C	A	L	P	F	C	L	T
Time [h]	72	72	48	12	24	12	24	24	48	24	12	24	72
Prop. Power [MW]	3.67	1.84	3.67	17.8	1.84	7.06	0	0.7	1.84	17.8	7.06	0.7	3.67
Elec. Power [MW]	0.66	0.77	0.66	0.77	0.77	0.9	0.45	0.76	0.77	0.77	0.9	0.76	0.66

Next to the operational profile and ‘eligible’ power plant components, client preferences are needed as input to the CET. These are given as weight factors for different design criteria in Table 3.

Table 3: Client preferences as input to case study Frigate 1A and 1B.

Criterion	Efficiency	Emissions	Volume	Mass	Signatures	Robustness
Weight factor (1-10)	4	2	8	6	8	10

#### 4.2. Frigate – Output (Results)

The design space, filled with generated, evaluated and ranked naval power plant configurations, is visualised in a 2D-plot in Figure 5 and Figure 6 for the Frigate case studies 1A and 1B (with or without fuel cells). Each point in the plots represents one or more configurations (configurations may be on top of each other if they score exactly equal), a Pareto front is visible as well as the chosen ‘optimal’ design given the weight factors of Table 3 as quantified client preferences. Note that the optimal concept may not be on the Pareto front (as is the case for Figure 6), because the 2D-plot only shows information for two design criteria and not all six.

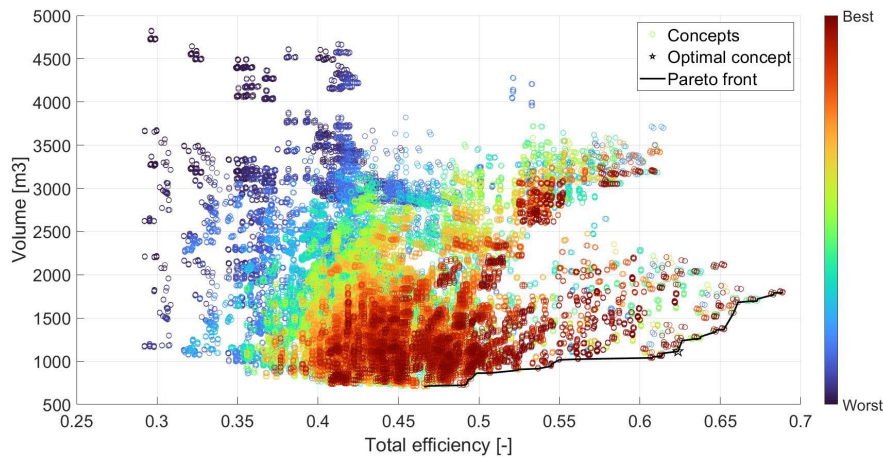

Figure 5: Design space visualisation in Efficiency – Volume plot for case study 1A.

Table 4: ‘Optimal’ configurations for case study 1A, including KPI values, according to CET.

Case 1A	Type	Value	Unit	KPI	Value	Unit
Propeller	2x CPP	-	-	Efficiency	0.62	
Gearbox	2x	15.6	MW	CO2	574.5	ton
MPE	2x EM	15.6	MW	SOx	0	ton
EGS	3x SOFC	14.0	MW	NOx	0	ton
ESS	-	-	kWh	Volume	1114	m <sup>3</sup>
Fuel	LNG	225	Ton	Mass	741	ton
				Signatures	0.9	MW
				Robustness	0.94	-

The ‘optimal’ power plant configurations are provided in Table 4 and Table 5. The chosen ‘optimal’ concepts in both cases have some surprising features. In that sense the CET performs well; it provides answers that human designers would probably not contemplate. However, the ‘optimal’ answers are probably considered ‘odd’ and are



improved relatively easily by experienced power and propulsion system engineers. This unfortunately means that the results may not yet provide a lot of confidence in the quality of the CET's answers.

For instance, it seems rather odd that CPP's are chosen in case 1A and FPP's in case 1B. The latter is a rather conventional CODAD propulsion plant with a fully separated electric power system. The twin shaft propulsion system consists of two separate drive trains with two 4-stroke diesel engines per shaft. This will surely require CPP's in practice, rather than FPP's, if only to enable operation on one engine per propeller (to avoid overloading of the remaining engine when one engine fails).

The solution for Case 1A in fact is a full electric power plant and driven by the high efficiency of SOFC's no other options are chosen for power generation than SOFC's. This however means electric motors drive the two propellers, which would typically mean FPP's would be chosen. The main reason for choosing FPP's in such cases is costs (CAPEX), but since these are not taken into account in the CET (difficult to quantify accurately) the CET produces the result nonetheless. This is actually considered a very interesting, 'surprising' result of the CET as one could also provide good arguments for combining CPP's with electric drive. Especially with regards to acoustic signatures, highly important in naval applications, CPP's may provide better performance than FPP's when combined with proper pitch control – see (Geertsma, 2017).

Multiple reasons exist for the odd choices. First of all, not all design criteria are taken into account. Both initial costs (CAPEX) and operational costs (OPEX) are not taken into account by the current CET, while these obviously are important design drivers in practice. Not having the counteracting effect of costs is also the reason for both 'optimal' configurations being overpowered. The high weight factor given to robustness, and the way in which robustness is defined as an objective function, result in very large powers being installed for both cases (in case 1A almost twice as high as needed). Installing too much power is counteracted by requirements on mass and volume of the power plant and by the thermal signature objective function, but not sufficiently to avoid overpowering. At least not with the current client preferences.

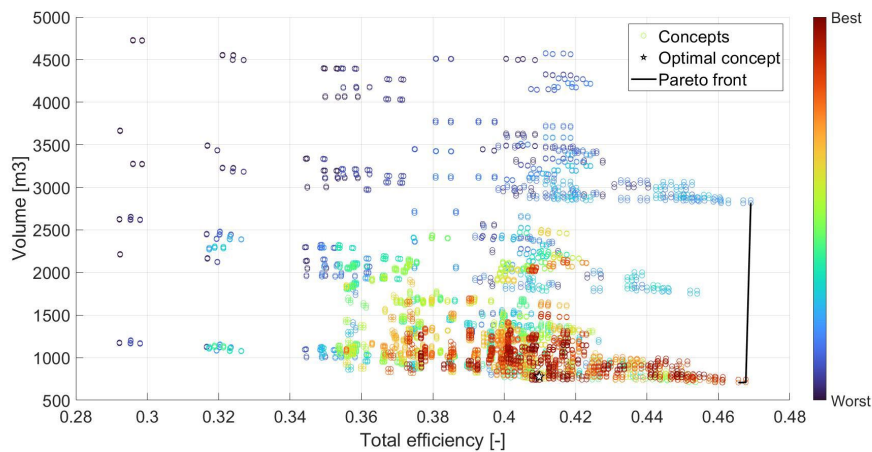

Figure 6: Design space visualisation in Efficiency – Volume plot for case study 1B.

Table 5: 'Optimal' configurations for case study Frigate 1A and 1B, including KPI values, according to CET.

Case 1B	Type	Value	Unit	KPI	Value	Unit
Propeller	2x FPP	-	-	Efficiency	0.41	
Gearbox	2x	13.8	MW	CO2	1423.4	ton
MPE	4x DE4	6.9	MW	SOx	1.8	ton
EGS	2x DG	0.9	MW	NOx	30.0	ton
ESS	-	-	kWh	Volume	777	m <sup>3</sup>
Fuel	MDO	449	ton	Mass	727	ton
				Signatures	2.0	MW
				Robustness	0.96	-

Even though it may be quite easy to criticise the ‘optimal’ results as outcome of the naval power plant CET, or rather, to improve them / make them more conventional, the results are not entirely unimaginable. Furthermore, the CET took only 417 seconds of runtime to generate, evaluate and rank 62872 concepts for case study 1A and 87 seconds to generate, evaluate and rank 4296 concepts for case study 1B. This shows the power of computer-aided design space exploration as an approach to early stages of the design process.

### 4.3. Other case studies

In the study underlying this paper two other case studies were performed; one for a relatively slow Ocean-going Patrol Vessel (OPV) and one for a faster OPV. The reader is referred to (de van der Schueren, 2022) to find the results for these case studies as well as for further information of the naval power plant CET described in this paper.

## 5. Conclusions

This paper aimed to demonstrate the potential and limitations of a naval power plant concept exploration tool. Compared to earlier versions, the tool has made enormous progress in terms of effectiveness; measured as a combination of computational performance (the time it takes to complete a generation and evaluation cycle) and flexibility in supporting a designer. With regards to quality of the generated design solutions, or more specifically, the quality of the evaluation of generated design solutions, improvement is still possible / necessary. Still, an interesting Marine Engineering design debate can already be started with the first results on e.g. the subject of implementation of CPP's in electrical propeller drives or the elimination of gearboxes in electrical drives, as shown in the 1A case study results. Furthermore, by varying the weight factors in the client preferences different optimal solutions can be found, enabling design space exploration ‘on the spot’, i.e. together with clients, to investigate the influence of their preferences. This is made possible by the high speed of the CET, generating and evaluating numerous concept designs in a matter of minutes.

A reader interested in the definition and further information / discussion of the objective functions / design criteria is referred to (de van der Schueren, 2022). One will find, as one could have guessed from the definitions and results presented in this paper, that there is ample room for improvement for some of the used objective functions. Especially the definitions of the design criteria ‘signatures’ and ‘robustness’ are rudimentary and do not fully capture these complicated naval design drivers. The determination of volume, mass, emissions and efficiency can be improved as well, but the authors are confident that these do already to a large extent comply with requirements one may have for such functions in early design stages.

## References

- van Dijk, J.: “Automatic Selection of an Optimal Power Plant Configuration”, MSc thesis, Delft University of Technology, 2018, <http://resolver.tudelft.nl/uuid:b67eae7d-4d5a-47d2-a320-cf0e14944852>.
- Geertsma, R.D., Negenborn, R.R., Visser, K., Loonstijn, M.A. & Hopman, J.J.: Pitch control for ships with diesel mechanical and hybrid propulsion: Modelling, validation and performance quantification”, Applied Energy, Volume 206, 2017, pages 1609–1631, <https://doi.org/10.1016/j.apenergy.2017.09.103>.
- Habben Jansen, A. C., de Vos, P., Duchateau, E. A. E., Stapersma, D., Hopman, J. J., van Oers, B. J. & Kana, A. A.: “A framework for vulnerability reduction in early stage design of naval ship systems”. Naval Engineers Journal, Volume 132(2), 2020, pages 119-132, <https://www.ingentaconnect.com/contentone/asne/nej/2020/00000132/00000002/art00022>.
- Huisman, T.J.: “Optimization of Ice-Class Propellers”, MSc thesis, Delft University of Technology, 2015, <http://resolver.tudelft.nl/uuid:0607236e-c6d1-41a7-873b-c487065cea34>.
- van Oers, B.J.: “A Packing Approach for the Early Stage Design of Service Vessels”, Doctoral thesis, Delft University of Technology, 2011, ISBN 9789065622839, <http://resolver.tudelft.nl/uuid:6be7582c-63b1-477e-b836-87430bcfb43f>.
- Pouw, C.P.: “Development of a Multiobjective Design Optimization Procedure for Marine Propellers. A case study to the trade-off between efficiency and cavitation performance”, MSc thesis, Delft University of Technology, 2007, <http://resolver.tudelft.nl/uuid:f3e1711d-6968-4ade-9b9d-f5a6e1a683e1>.
- Paparistodimou, G., Duffy, A., Knight, P., Whitfield, I., Robb, M. & Voong, C.: “Network-based metrics for assessment of naval distributed system architectures”, Proceedings of the International Naval Engineering Conference 2018 (INEC), Glasgow, United Kingdom, October 2018, <https://doi.org/10.24868/issn.2515->

818X.2018.030.

Piperakis, A.S.: “An Integrated Approach to Naval Ship Survivability in Preliminary Ship Design”, Doctoral thesis, UCL (University College London), 2013, <https://discovery.ucl.ac.uk/id/eprint/1399992>.

de van der Schueren, T.: “A Digitised Exploration into the Design Space of Naval Power Plants”, MSc thesis, Delft University of Technology, 2022, <http://resolver.tudelft.nl/uuid:2e744007-b92e-4827-89bd-daebcd6fda66>.

Stapersma, D. & de Vos, P.: “Dimension prediction models of ship system components based on first principles”, in Proc. of 12<sup>th</sup> Int. Marine Design Conference (IMDC), 2015, [https://www.researchgate.net/publication/284646411\\_Dimension\\_prediction\\_models\\_of\\_ship\\_system\\_components\\_based\\_on\\_first\\_principles](https://www.researchgate.net/publication/284646411_Dimension_prediction_models_of_ship_system_components_based_on_first_principles).

de Vos, P.: “On the application of network theory in naval engineering: Generating network topologies”, Proceedings of the International Naval Engineering Conference 2014 (INEC), Amsterdam, The Netherlands, 20-22 May 2014, <https://library.imarest.org/record/3065>.

de Vos, P. & Stapersma, D.: “Automatic Topology Generation for early design of on-board Energy Distribution Systems”, Ocean Engineering, Volume 170, 2018, Pages 55-73, <https://doi.org/10.1016/j.oceaneng.2018.09.023>.

de Vos, P.: “On early-stage design of vital distribution systems on board ships”, Doctoral thesis, Delft University of Technology, 2018, ISBN 978-94-6380-063-1, <https://doi.org/10.4233/uuid:eb604971-30b7-4668-ace0-4c4b60cd61bd>.

Vrijdag, A., Stapersma, D. & van Terwisga, T.: “Control of propeller cavitation in operational conditions”, Journal of Marine Engineering & Technology, Volume 9(1), 2010, pages 15–26, <https://doi.org/10.1080/20464177.2010.11020228>.

#### **Appendix I: Pseudo code for the Naval Power Plant CET algorithm**

1. Load components list, operational profile, client preferences and model settings
2. Generate concept vector
3. Generate concept matrix
4. Save vector and matrix to concept library
5. Load concept library
6. Determine minimum installed MPE power (combined power of all Main Propulsion Engines)
7. Design shaft configuration
8. Design and size MPE components
9. Simulate mission for MPE components
10. Design electric grid
11. Determine electric mission profile
12. Determine minimum installed EGS power (total power of Electric Power Generation System)
13. Design and size EGS components
14. Design and size ESS components (capacity of Energy Storage System)
15. Simulate mission for EGS and ESS components
16. Simulate fuel usage and size tanks
17. Determine robustness
18. Combine results and determine final score
19. Present output