

# academic and innovation campus the hague

*navigating university identity*

design journal public buildings  
AR3A010 msc 3 - 4  
TU Delft

thom peperkamp



# The Hague CID

Framework

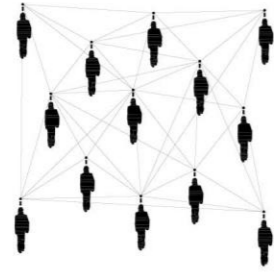

Innovation

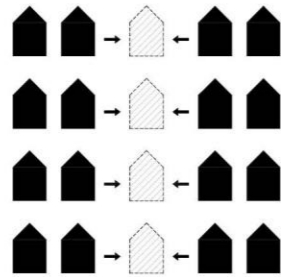

Densification



Dynamic urban living

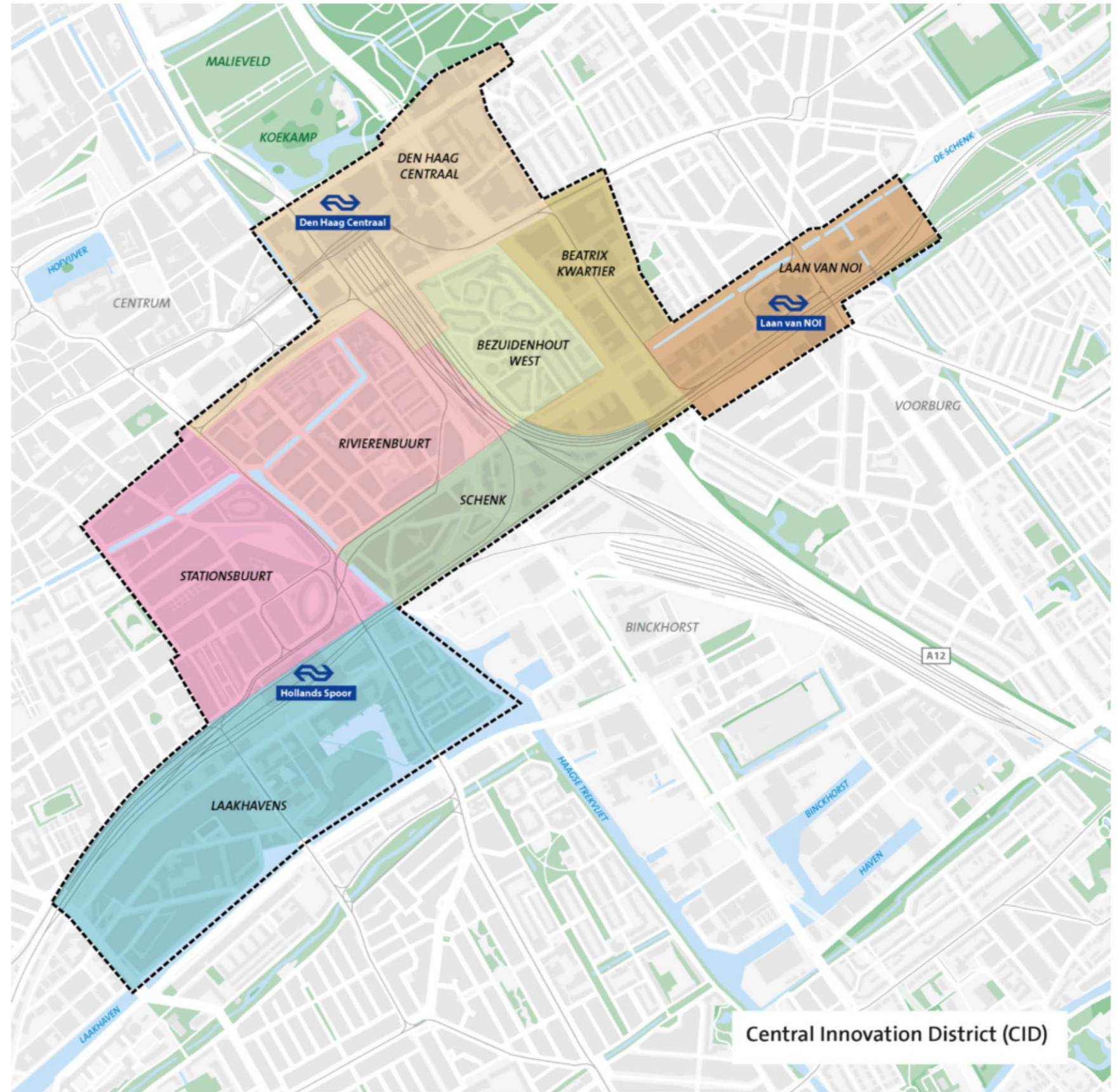

# Central Station area

Brief history



1945



2024

# Central Station area

The Hague



# Central Station area

The Hague

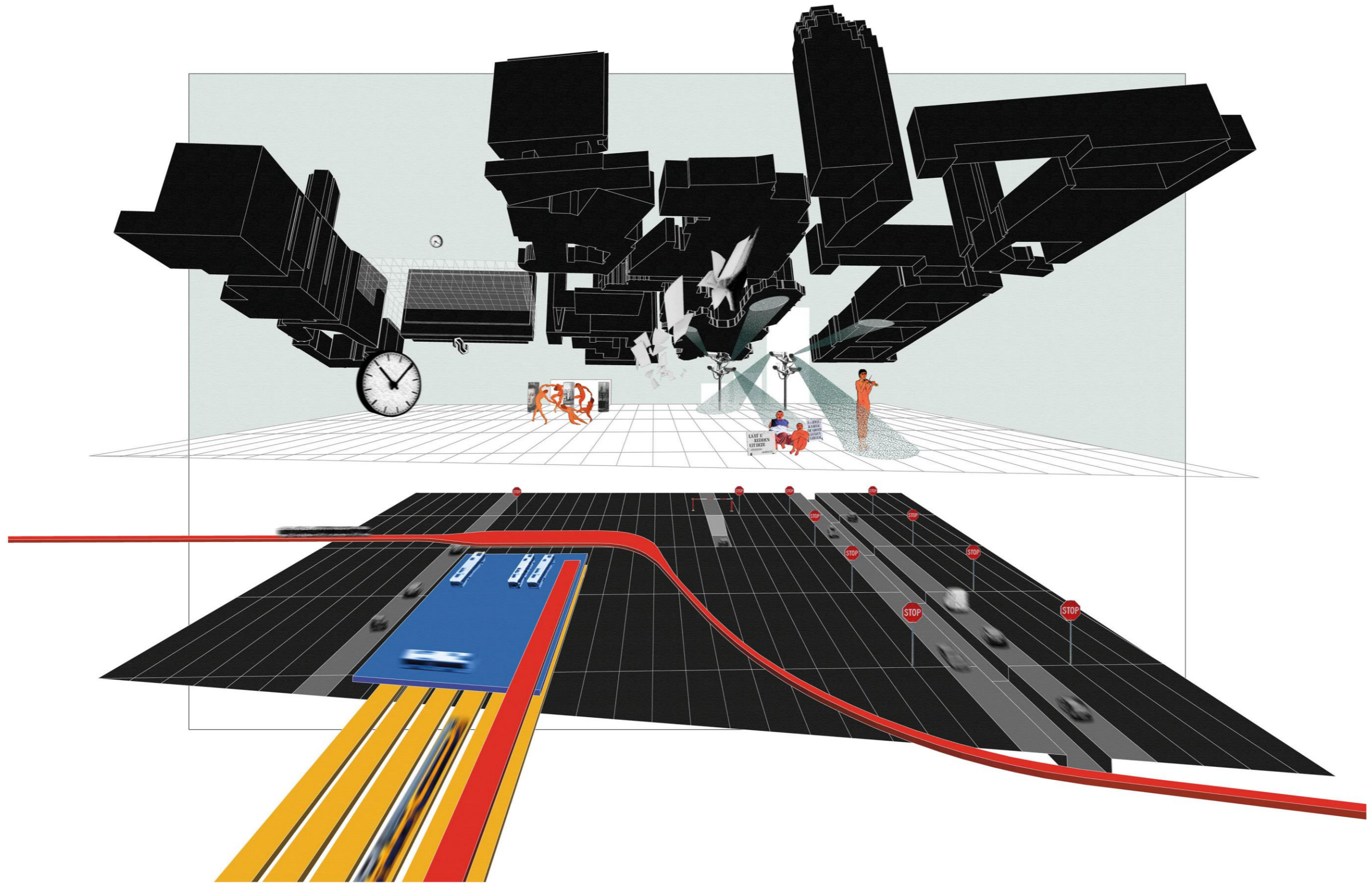

# Where to build?

Prins Clauslaan

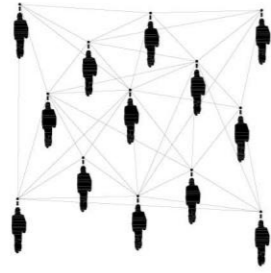

**Innovation**

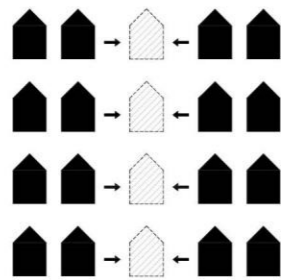

**Densification**



**Dynamic urban living**



# Prins Clauslaan

Figure ground study

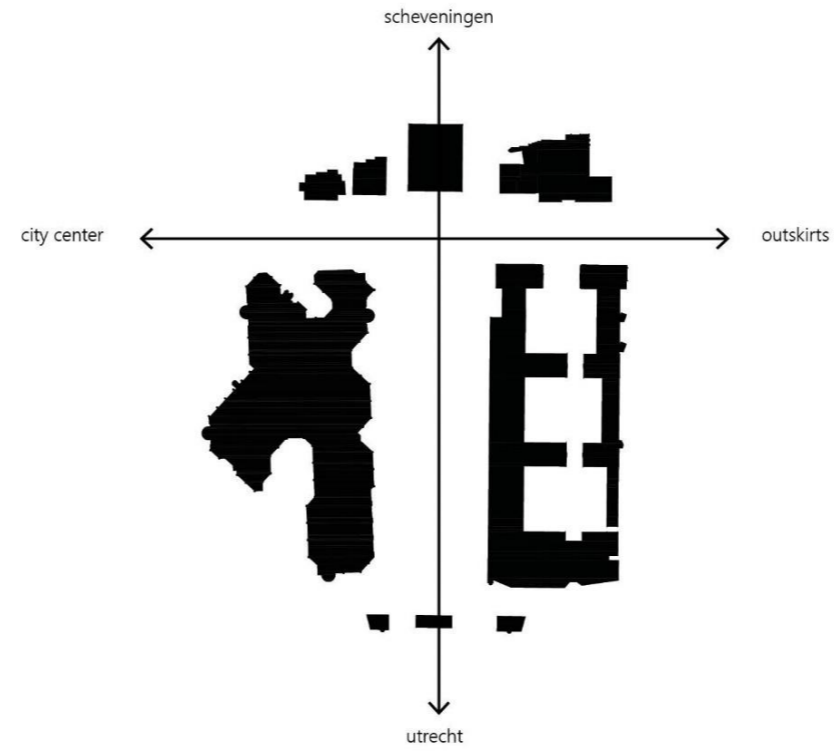

Navigation

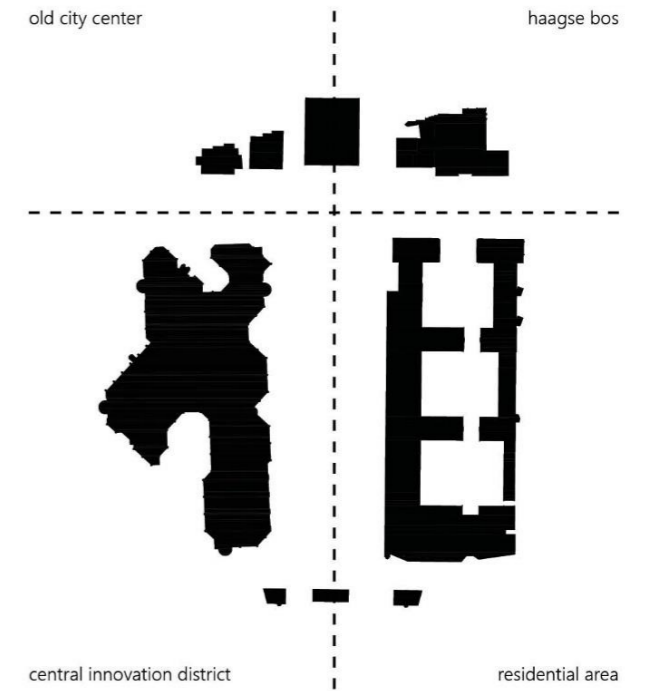

Different urban entities

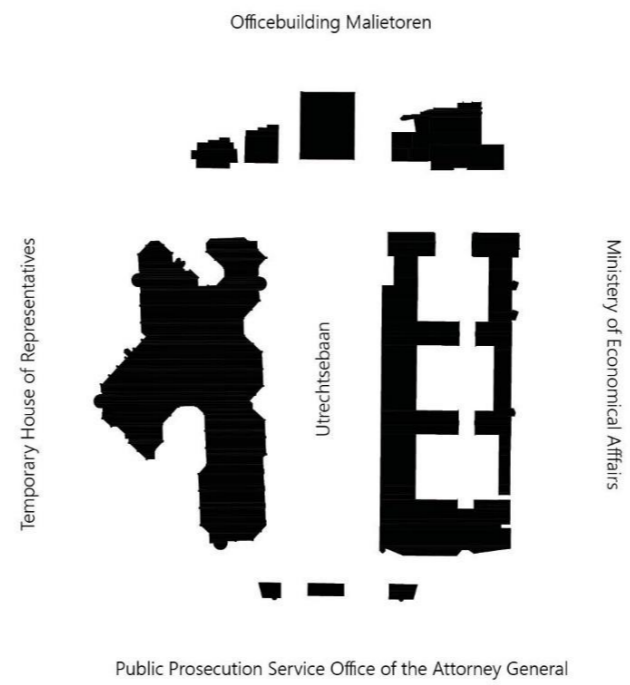

Urban islands

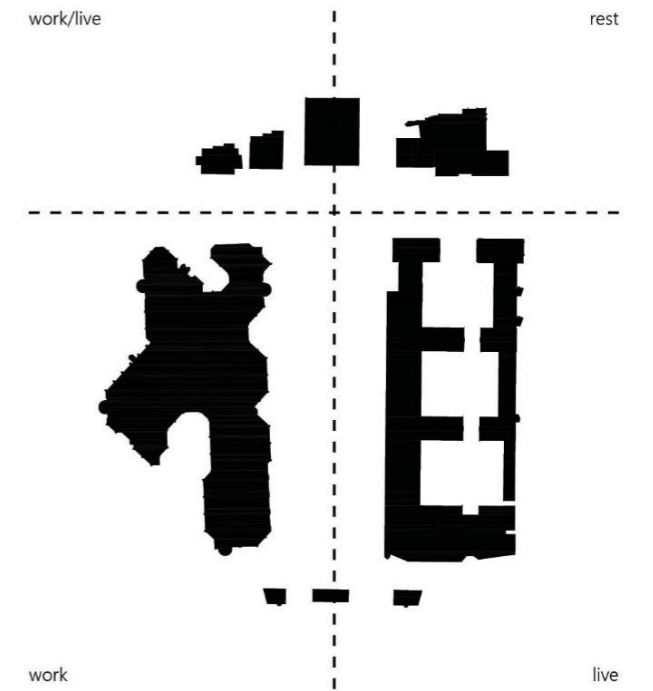

Different urban identities

# Prins Clauslaan

Urban identity

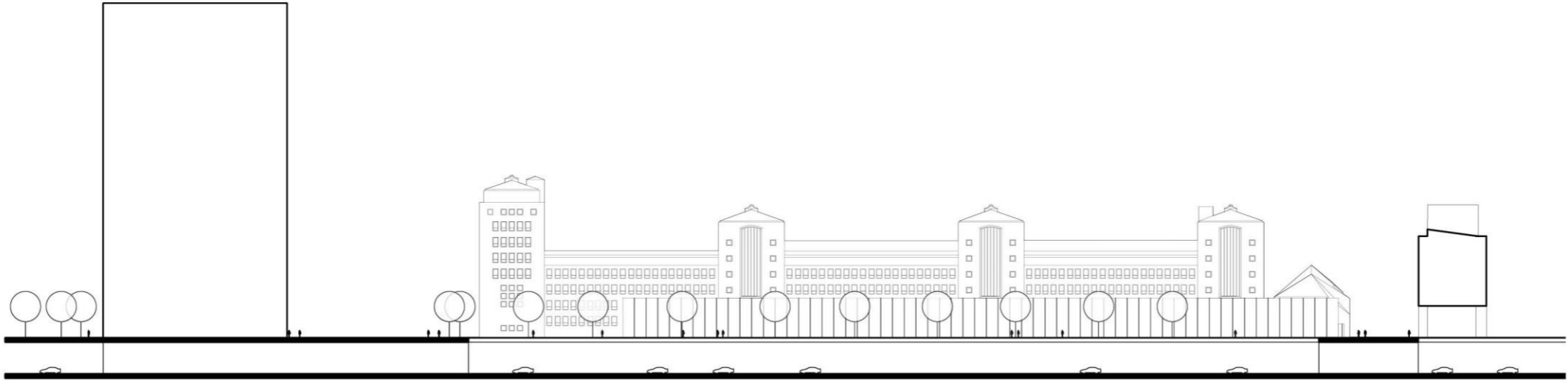

Ministry of economical affairs



# Prins Clauslaan

Urban identity

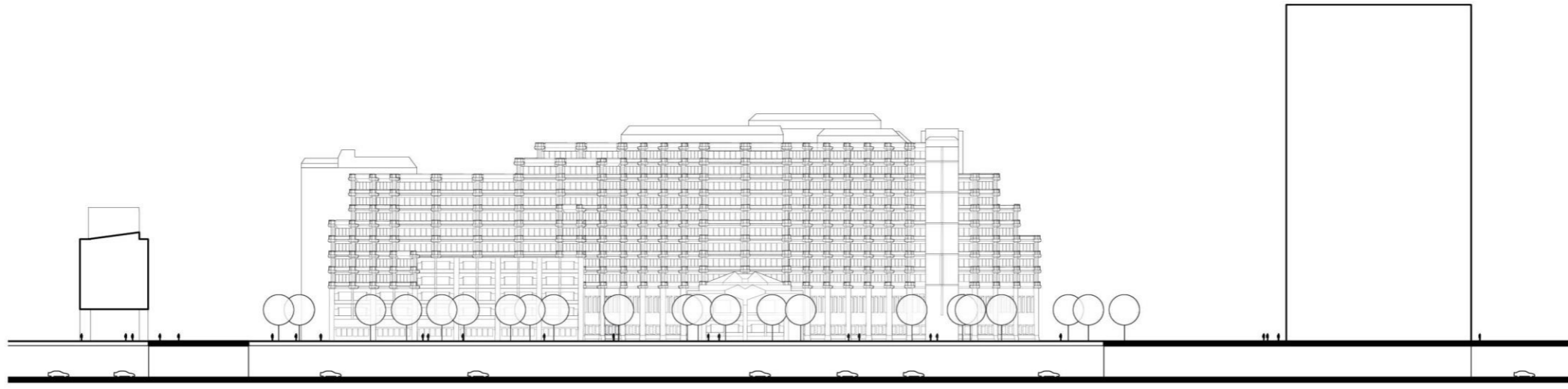

Temporary house of representatives

# Urban identity

Prins Clauslaan

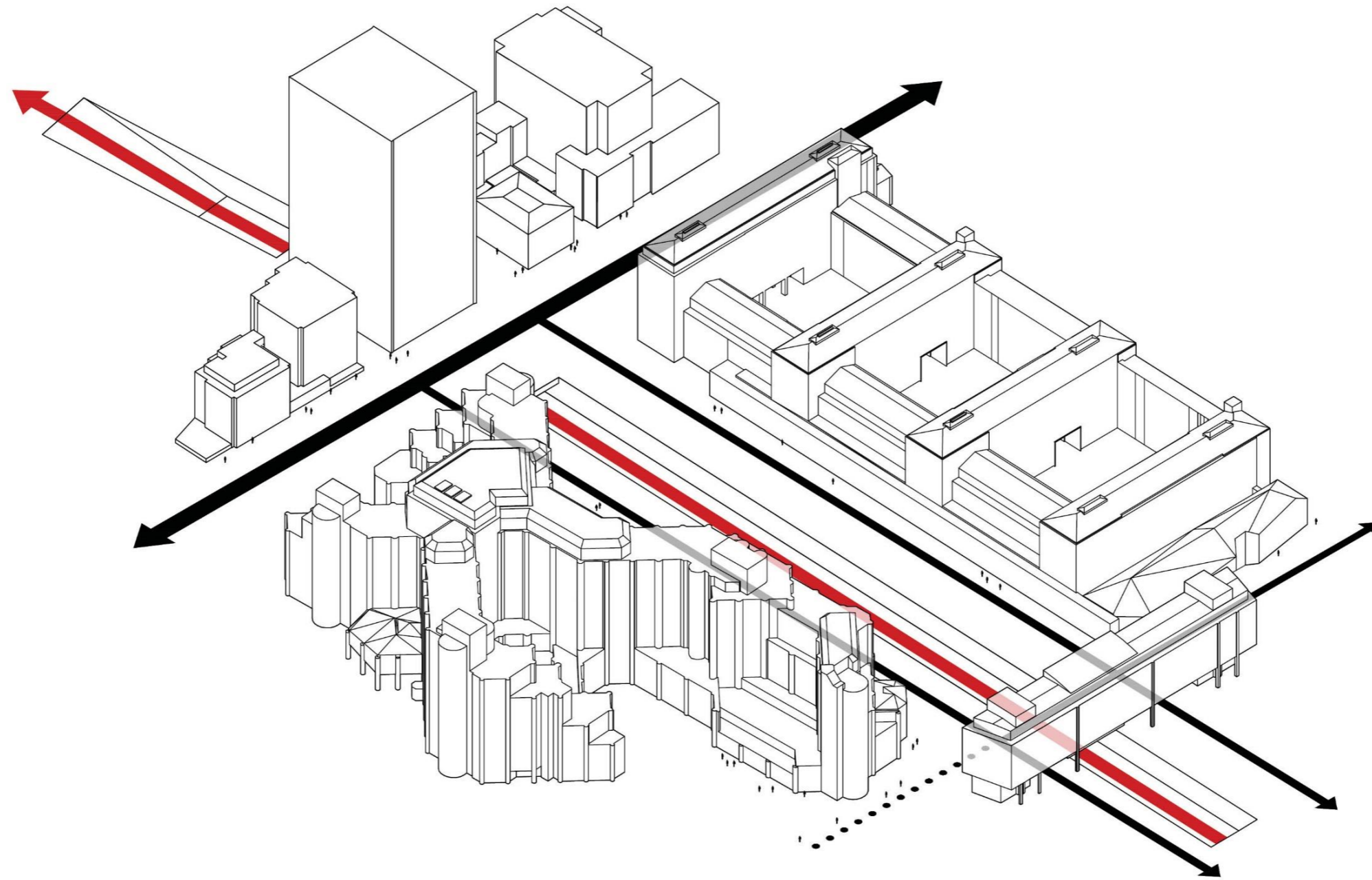

# Who are the target groups?

For a public condenser in Central Station area

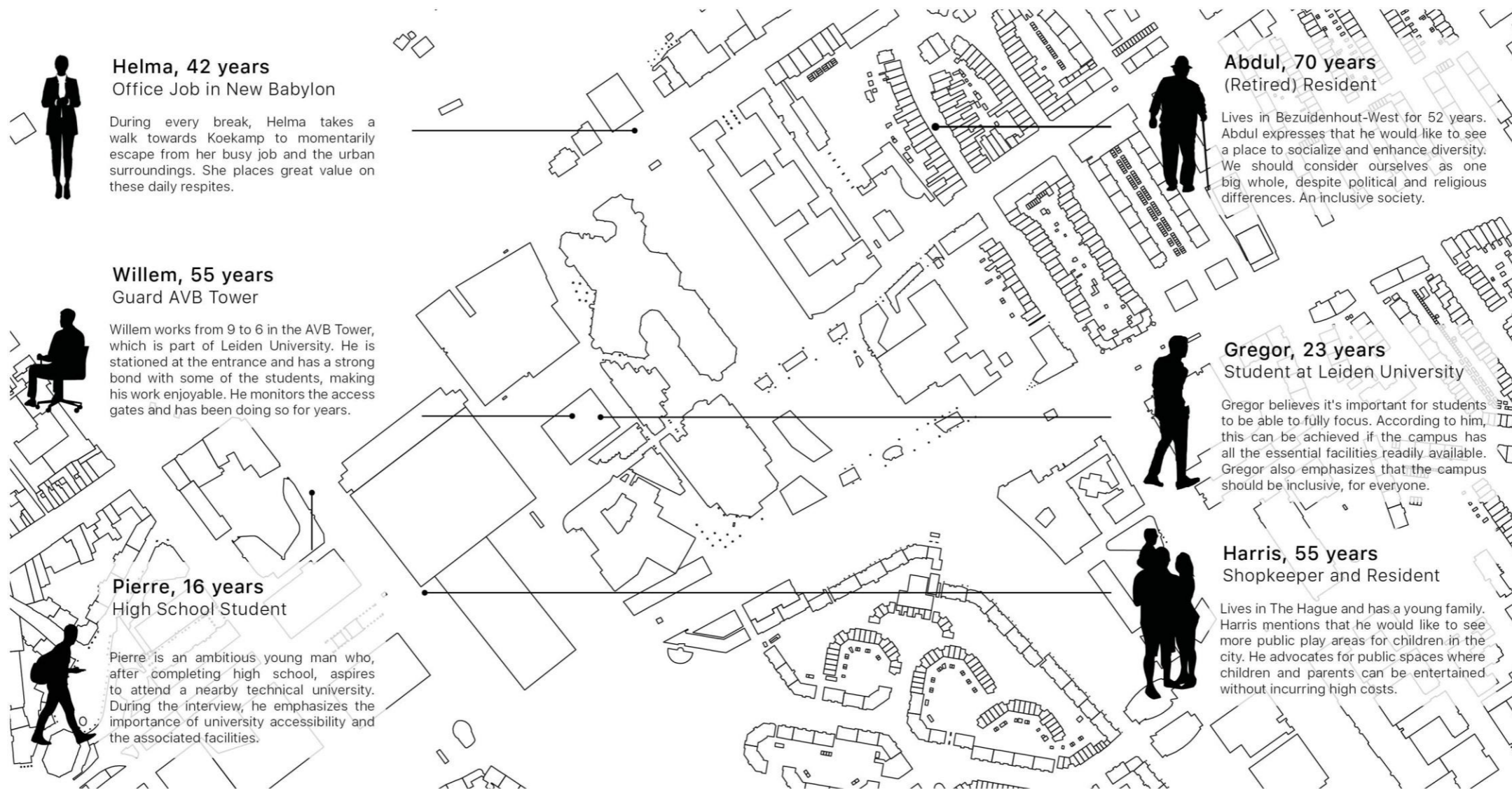

**Helma, 42 years**  
Office Job in New Babylon

During every break, Helma takes a walk towards Koekamp to momentarily escape from her busy job and the urban surroundings. She places great value on these daily respites.

**Willem, 55 years**  
Guard AVB Tower

Willem works from 9 to 6 in the AVB Tower, which is part of Leiden University. He is stationed at the entrance and has a strong bond with some of the students, making his work enjoyable. He monitors the access gates and has been doing so for years.

**Pierre, 16 years**  
High School Student

Pierre is an ambitious young man who, after completing high school, aspires to attend a nearby technical university. During the interview, he emphasizes the importance of university accessibility and the associated facilities.

**Abdul, 70 years**  
(Retired) Resident

Lives in Bezuidenhout-West for 52 years. Abdul expresses that he would like to see a place to socialize and enhance diversity. We should consider ourselves as one big whole, despite political and religious differences. An inclusive society.

**Gregor, 23 years**  
Student at Leiden University

Gregor believes it's important for students to be able to fully focus. According to him, this can be achieved if the campus has all the essential facilities readily available. Gregor also emphasizes that the campus should be inclusive, for everyone.

**Harris, 55 years**  
Shopkeeper and Resident

Lives in The Hague and has a young family. Harris mentions that he would like to see more public play areas for children in the city. He advocates for public spaces where children and parents can be entertained without incurring high costs.



## (Upcoming) Students

*They yearn for as many facilities as possible to be within easy reach.*



## Local Residents

*Strive for a calm, pleasant and decent atmosphere.*



## Office Laborers (Commuters)

*During breaks, they seek opportunities to relax outside of work.*

# Enough places to socialize?

Core numbers of Bezuidenhout

## Age

Residents to age

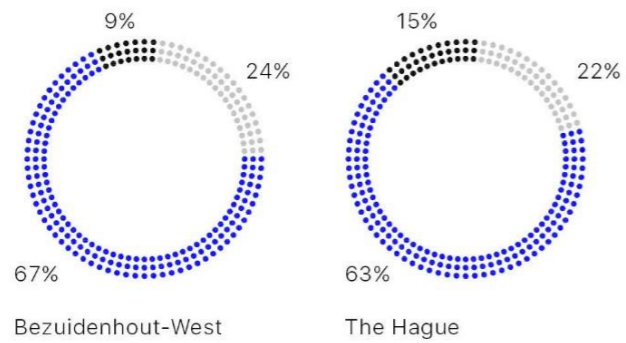

- 0 to 19 years
- 25 to 64 years
- 65 and older

## Households

In composition

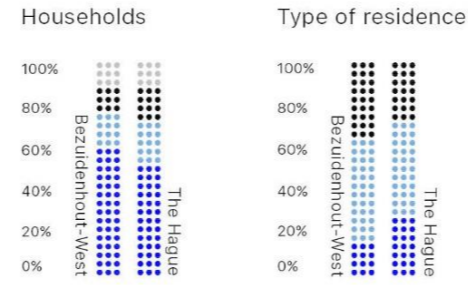

- One-Parent family
- Co-Habitat + Children
- Co-Habitat
- Single Person
- Ownership undetermined
- Owner-occupied ownership
- Private rental
- Social housing

## Facilities

Distance to different facilities

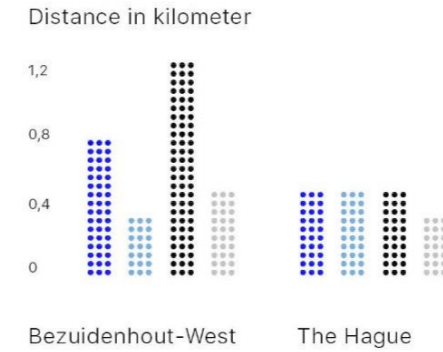

- Grocery store
- Primary school
- Family doctor's practice
- Big supermarket

Source: DHIC/GDH/DPZ (2022)

## Disturbance

Reports of nuisance

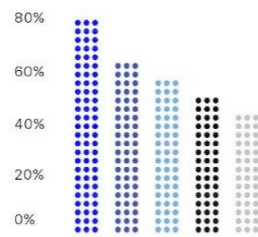

- Youth
- Litter on the street
- Dog feces
- Noise pollution
- Fast driving

## Enough places to socialize?

The satisfaction of the residents

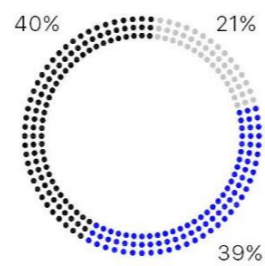

- Agree
- Neutral
- Not agree

## Feels safe

From nuisance to crime.

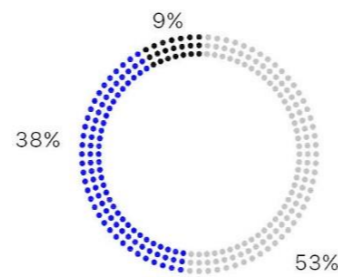

- Agree
- Neutral
- Not agree

## Feels at home

In Bezuidenhout-West

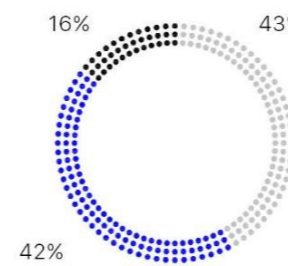

- Agree
- Neutral
- Not agree

## Health

The fitness of the neighbourhood

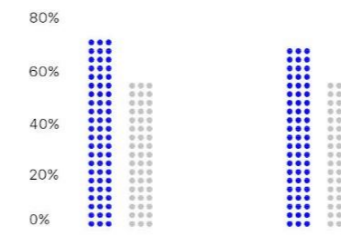

- Meets the physical activity guidelines
- Is in good health

# Urban strategy

Prins Clauslaan

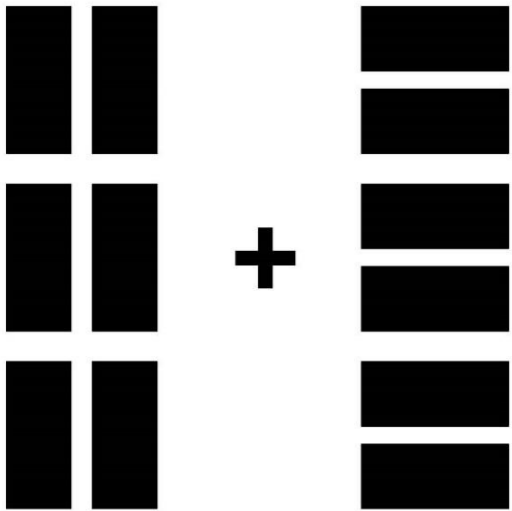

Connecting neighbourhoods

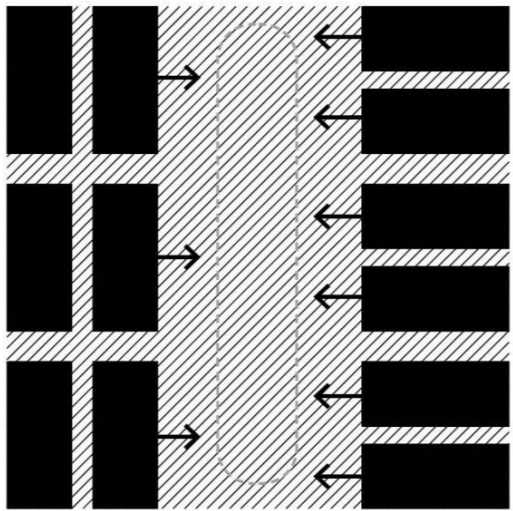

Extending the public domain

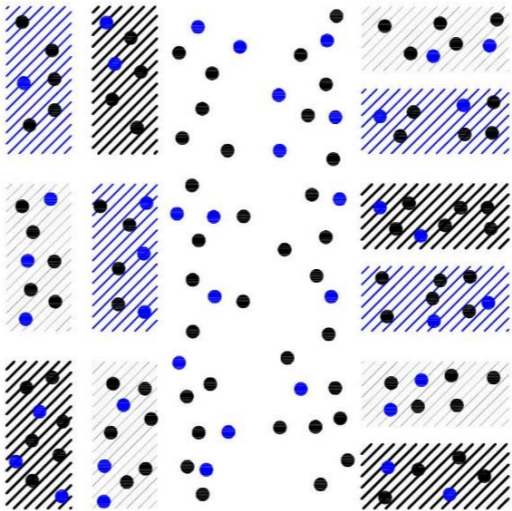

Merge different target groups

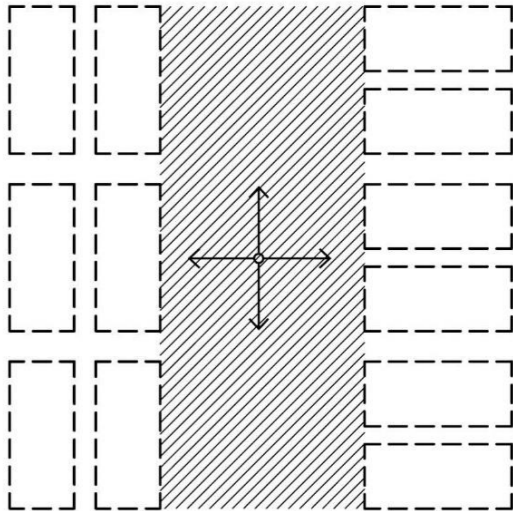

Flexibility

# What are the urban potentials?

Prins Clauslaan

## FROM...

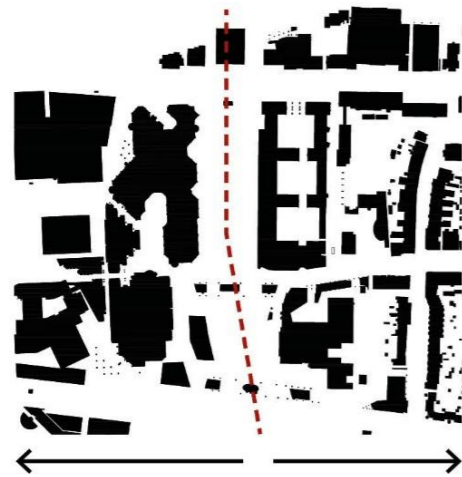

Cut off neighbourhoods



Poor public domain

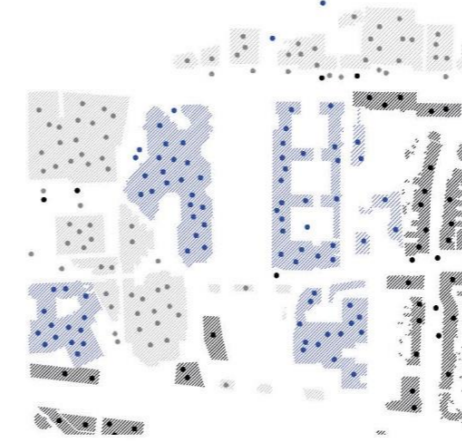

Different identities



Rigid

## TO...



Connecting neighbourhoods

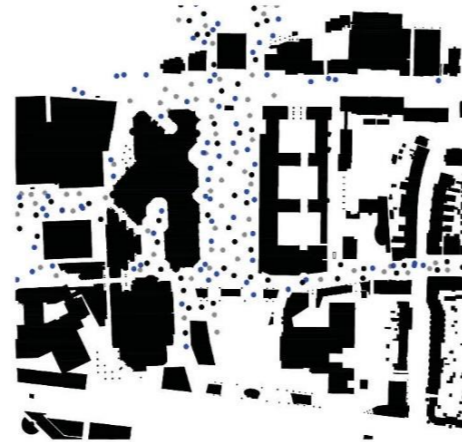

Extending the public domain



Merge different identities



Adaptivity and flexibility

# How?

Design task

## Public building

*To connect and enrich*

## Vertical campus

*To learn and innovate*

**+/- 30.000 m<sup>2</sup>**

*To facilitate and densify*





# Campus timeline

Academic progression through time

A community of intellectuals sharing ideas in places, such as forums



Forum

Universities emerge and integrated more into city life



Arabic Schools

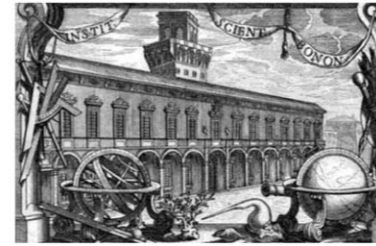

1088

First European University

The special legal status of universities causing friction with surrounding communities

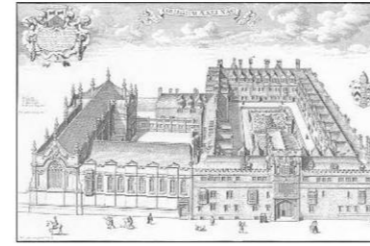

1096

Oxford and Cambridge Colleges



1222

University of Padua

Universities engaging in broader cultural movements, shaping multiple facets of society



1460

University of Basel

Integrating Enlightenment principles into campus design to create a comprehensive educational setting



1624

First American University

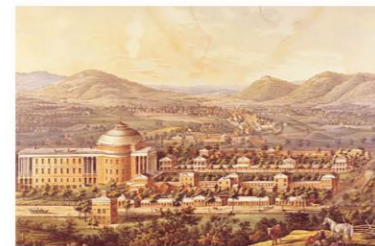

1819

Virginia University Campus



1861

MIT

Rising demand for higher education driving the creation of innovative campus models



1956

Shifting to Modern Era Campus



2000

Opening up

Global challenges like climate change and globalization shaping the culture and design of campuses



2024

Vertical and off campus

NEW TYPOLOGY?

Campus of the future

# What identity do others reflect?

Vertical campus references

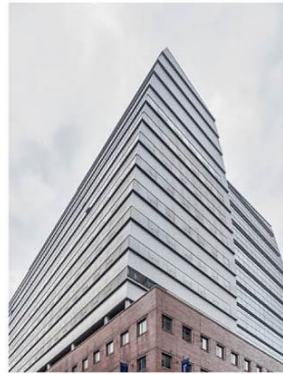

2001

Newman Vertical Campus  
Kohn Pedersen Fox



2012

Roosevelt University  
VOA Associates



2013

AVB Tower  
Wiel Arets Architects



2014

The New School  
University Center  
SOM



2015

Roy and Diana Vagelos  
Educational Center  
DS+R and Gensler



2022

Jacoba Mulderhuiss  
Powerhouse Company and MKA

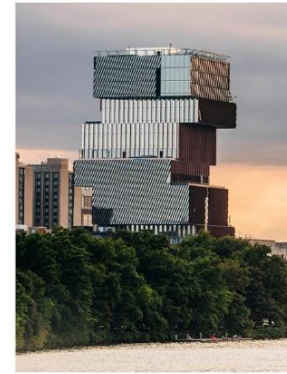

2023

Boston University Center  
KPMB Architects

# AvB Tower

Wiel Arets

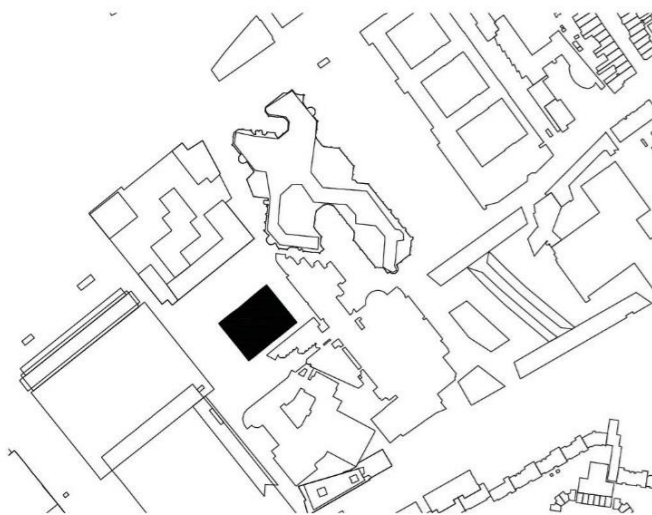

**Location**  
The Hague, Netherlands

**Status**  
Build

**Year**  
2013

**Occupant**  
University of Leiden

**Type**  
Hybrid Vertical Campus

**Size**  
24.500 m<sup>2</sup>

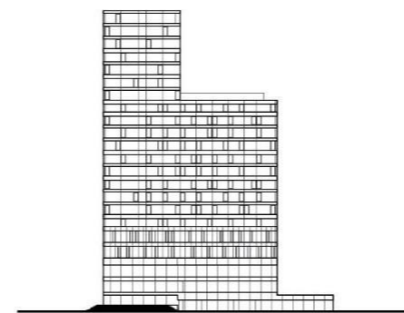

Elevation

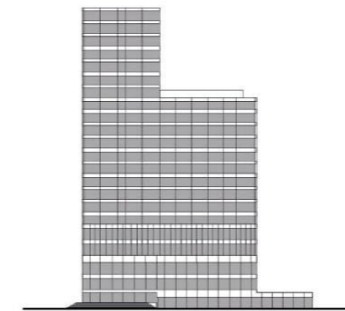

Repetitive to unique

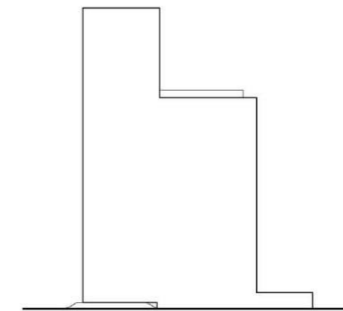

Massing

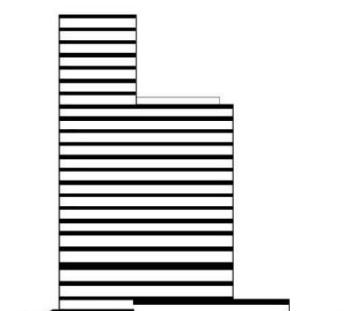

Solid to form

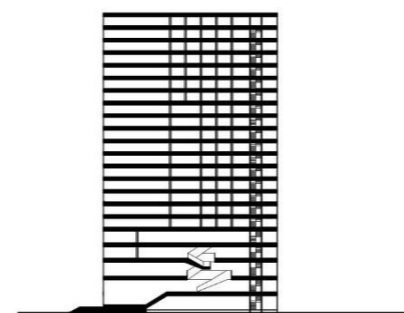

Section

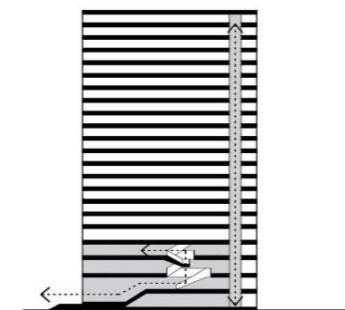

Circulation to use



Program to whole

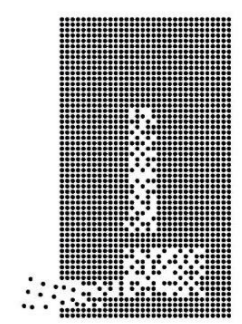

Solid-Liquid-Gas

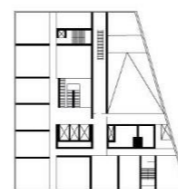

Floorplan



Circulation to use



Program to whole



Solid-Liquid-Gas

# What identity do others reflect?

Avb Tower

## Site

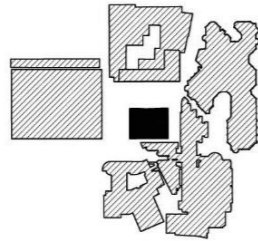

### One of the Archipelago

The urban fabric of the AVB Tower is an island structure

## Structure

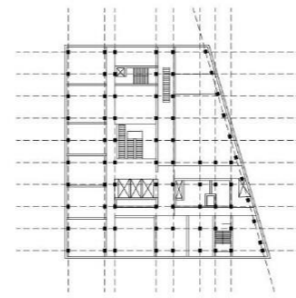

### All steel structure

Makes the floorplan flexible, without load bearing walls

## Skin

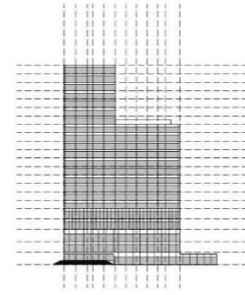

### Generic grid composition

The generic design is no other than a typical office tower

## Space

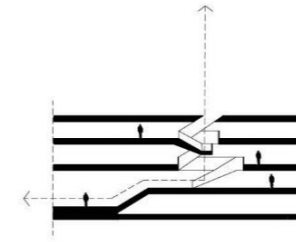

### Central staircase

The staircase, that starts at ground floor, stimulates interaction

## Stuff

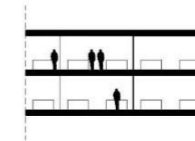

### Clinical and repetitive

The clinical white appearance and repetitive layout enhance focus.

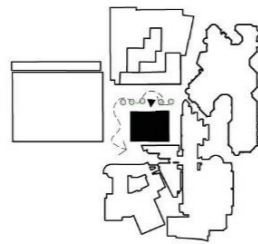

### Front square

The square at the front provides space for the students to interact

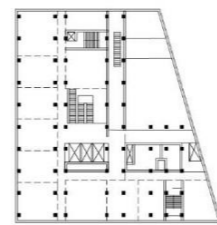

### Flexible infill

Light wall elements and glass provides flexibility and openness

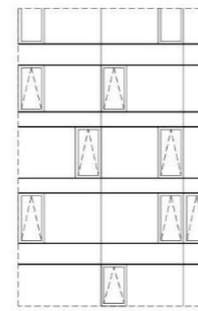

### Human scale facade

Windowframes that can be manually opened gives the user

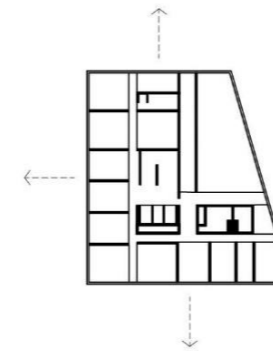

### Cell structure

Cell structure places alongside the glass facades

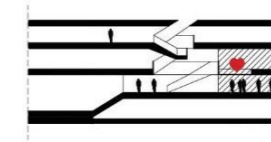

### Social hub

The social hub inside the building is connected to the central staircase

# Toolbox

University identity

## Site

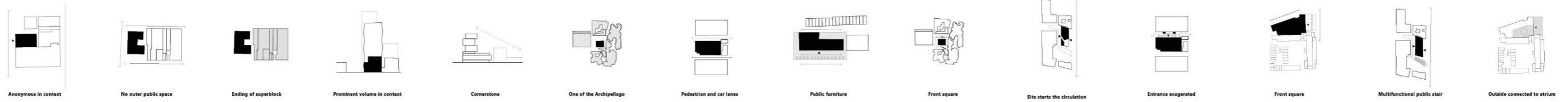

## Structure



## Skin

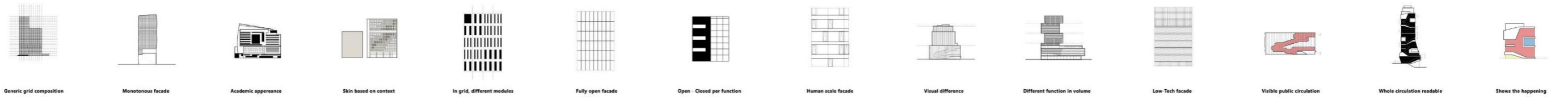

## Space

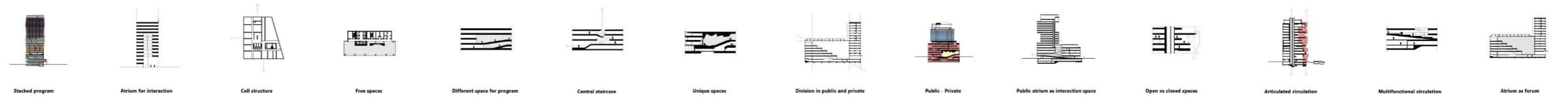

## Stuff

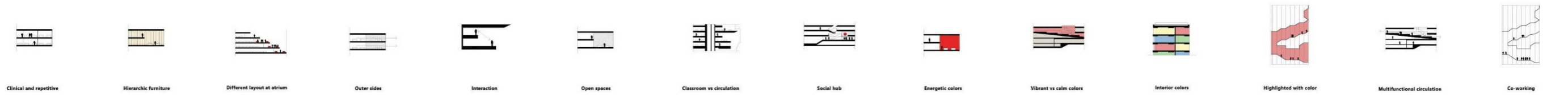

## Solid



## Gas

# Design principles

Based on research

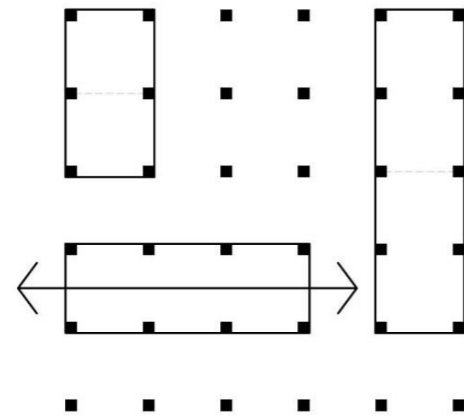

## Flexibility

Resilient to future

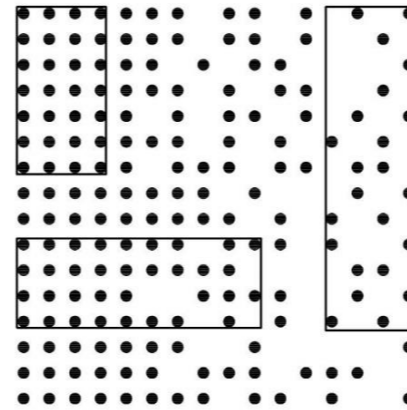

## Solid-Liquid-Gas

From Private to public spaces

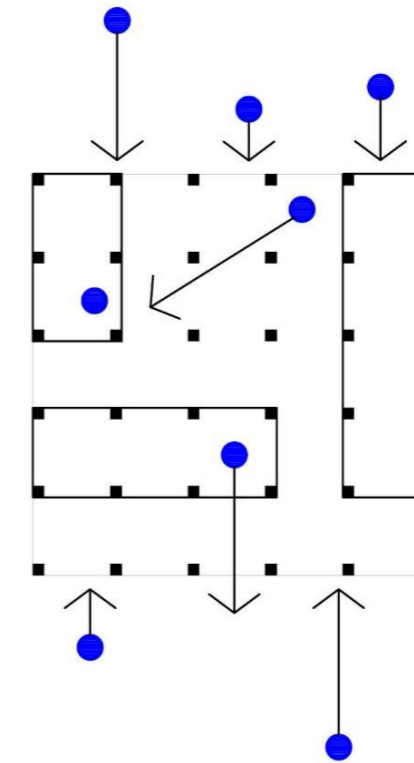

## Interactive

Sightlines and visibility

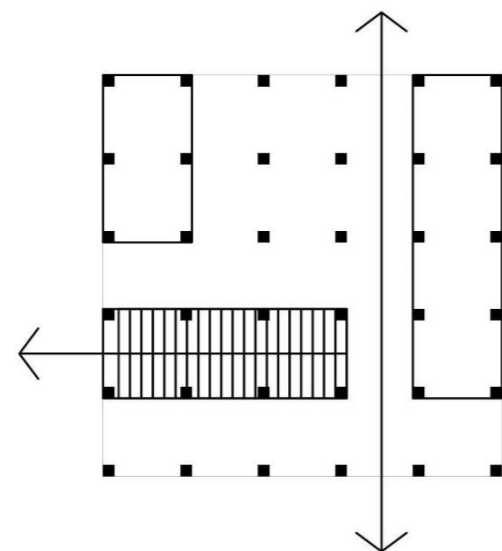

## Circulation in movement

Stimulate movement

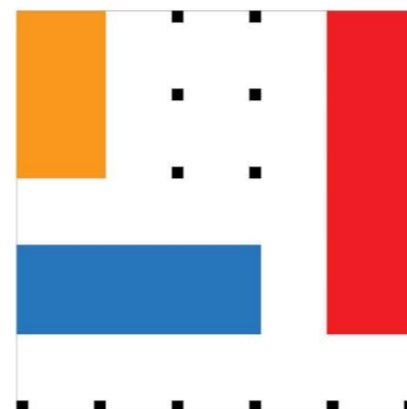

## Diverse functions

Invite people to certain happenings

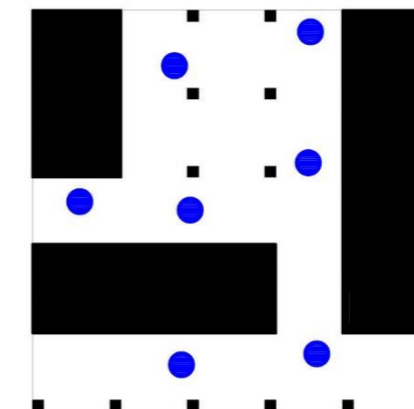

## Human scale

Spaces that feel well

# How to compose a campus structure?

Solid-liquid-gas

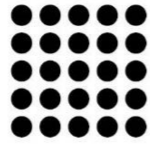

## Solid

On campus, fixed and traditional

- + **one workplace**
- + **exclusive**
- + **strong identity**
- territorial (island culture)
- high footprint
- closed doors

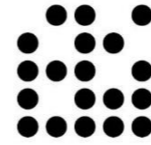

## Liquid

On campus, flexible and interconnected

- + **innovative**
- + **interconnected**
- + **flexible**
- anonymous
- crowded
- more mobility



## Gas

Off-campus, public domain

- + **accessible for many**
- + **paperless**
- + **24/7 mentality**
- lonely
- social isolation
- less loyal to university

## FROM SOLID...

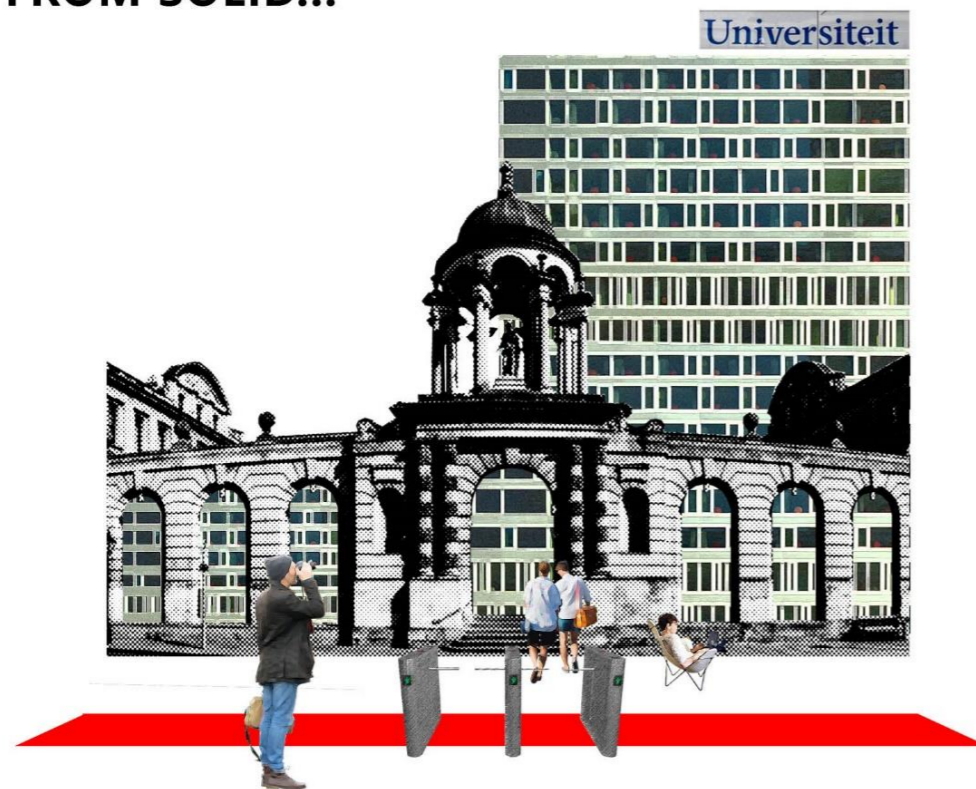

## TO MORE LIQUID/GAS...



# How to accomodate the program?

The solid-liquid-gas framework to organize the campus program

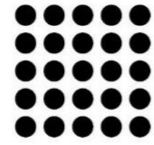

## Solid

On campus, fixed and traditional

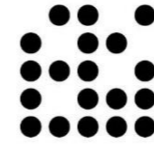

## Liquid

On campus, flexible and interconnected



## Gas

Off-campus, public domain

<b>Entrance</b>	Faculty-specific
<b>Commercial spaces</b>	Faculty related
<b>Café and Lounge</b>	Faculty coffe corner/restaurant
<b>Play and learn</b>	-
<b>Learn and discover</b>	At the faculty
<b>Library and media</b>	Faculty library
<b>Workshops</b>	Faculty-specific
<b>Digital center</b>	At the faculty
<b>Learn and develop</b>	Faculty-specific
<b>Teach, learn, develop</b>	Faculty-specific
<b>Lecture theatre</b>	Faculty-specific
<b>Exhibition space</b>	Faculty-specific
<b>Sports</b>	-
<b>Office</b>	Traditional workspace
<b>Storage</b>	Personal
<b>Parking</b>	-

Campus-specific
Campus-related
Campus restaurant
Merged into campus
On campus, shared facilities
University-shared
University-shared
On campus, shared facilities
University-shared
University-shared
University-shared
On campus, shared facilities
On campus, shared facilities
Shared rooms
Shared
University-shared

Public
Public or in the city
Public or in the city
Public or in the city
Off-campus or online
Public or in the city
Public
Public
Off-campus or online
Off-campus or online
Off-campus or online
Public
Public or off-campus
Third places or home
Digital
Public or in the city

**+/- 30.000 m<sup>2</sup>**



# How to accomodate the program?

How target groups behave in campus program

## Daily program use

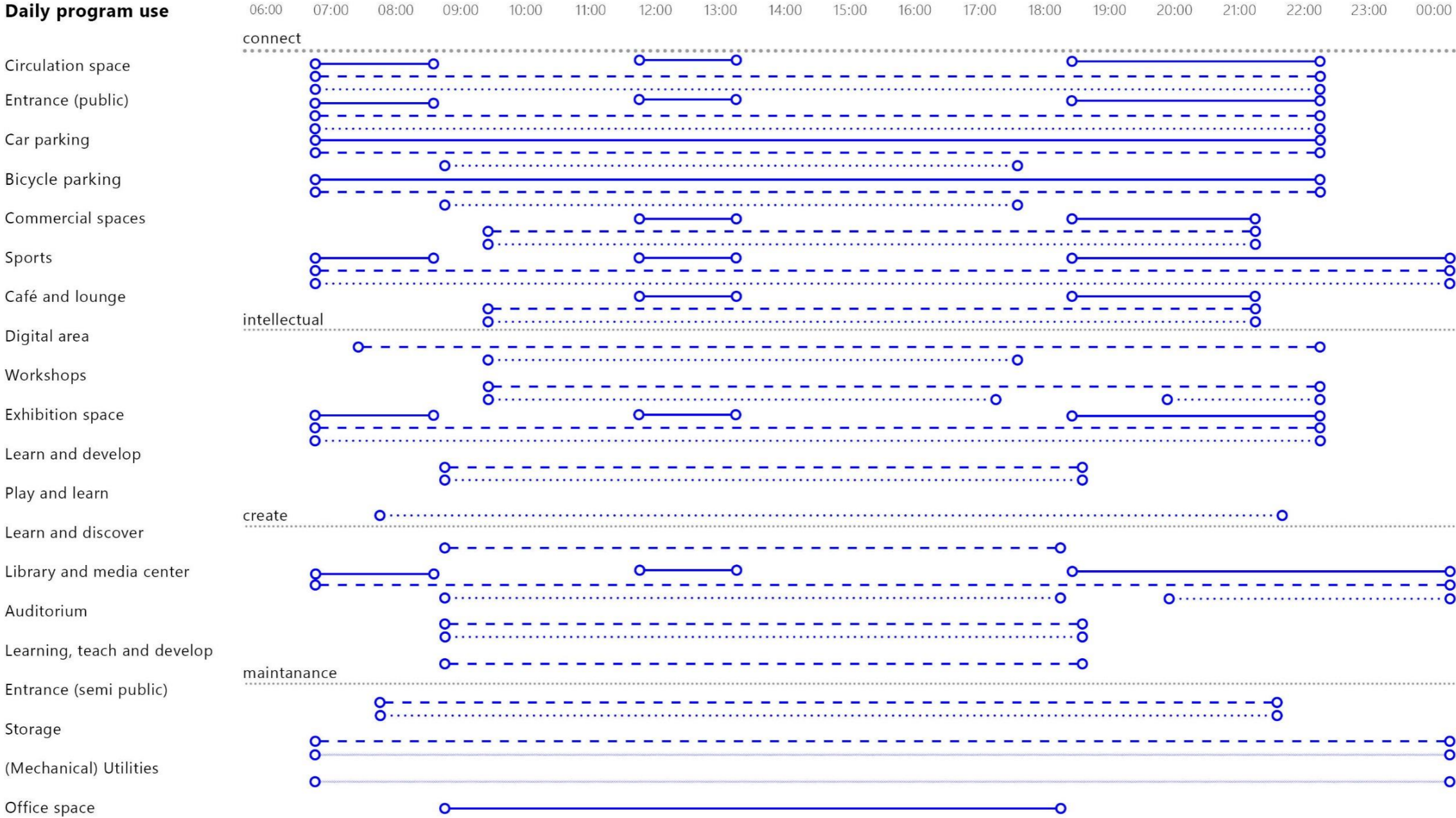

- Staff
- .....○ Other visitors
- - - -○ Students
- Office workers

# How to accomodate the program?

Program territory

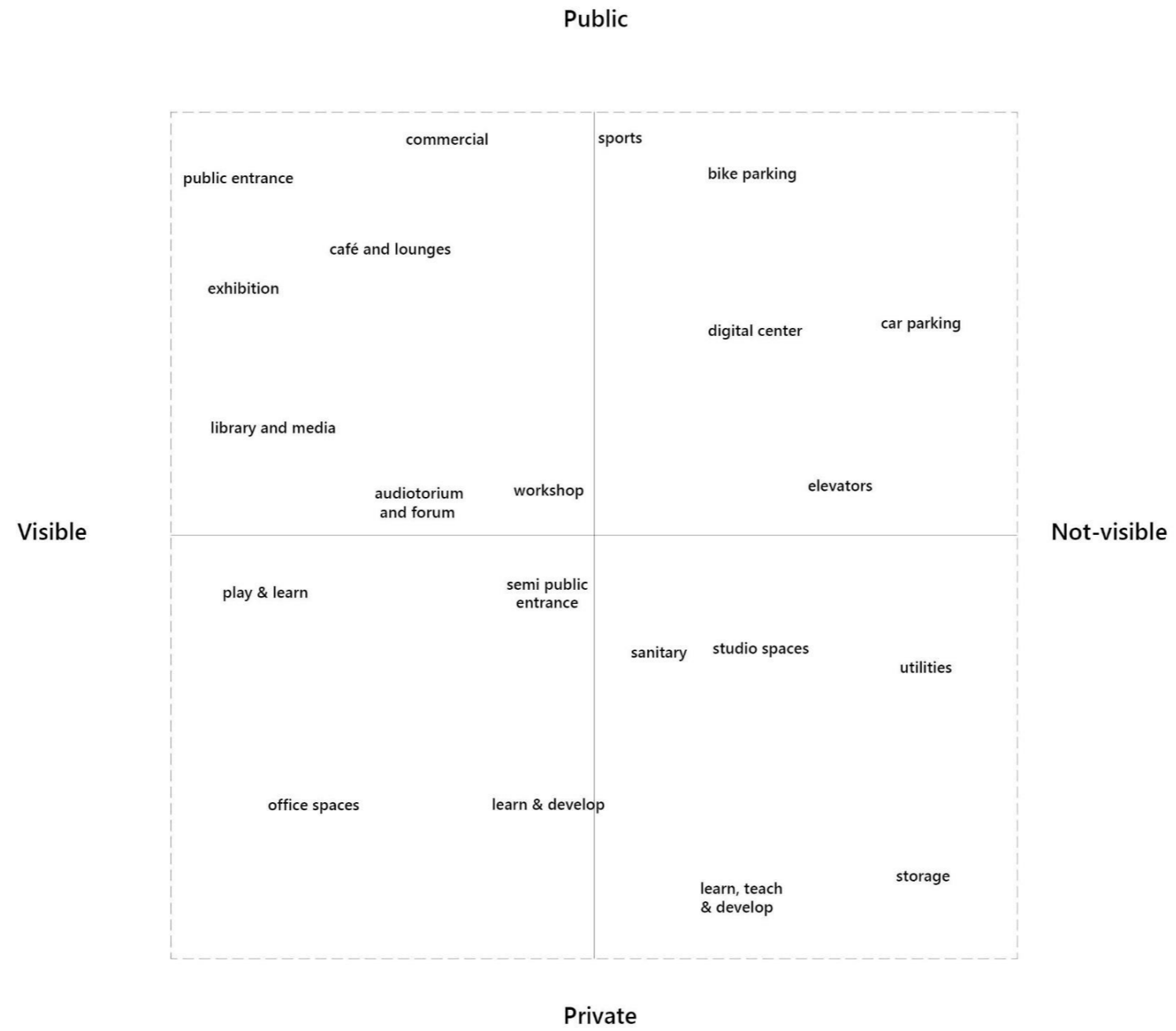

## Division of program

Visibility

# Schematic program distribution

Program in solid-liquid-gas

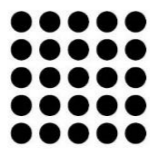
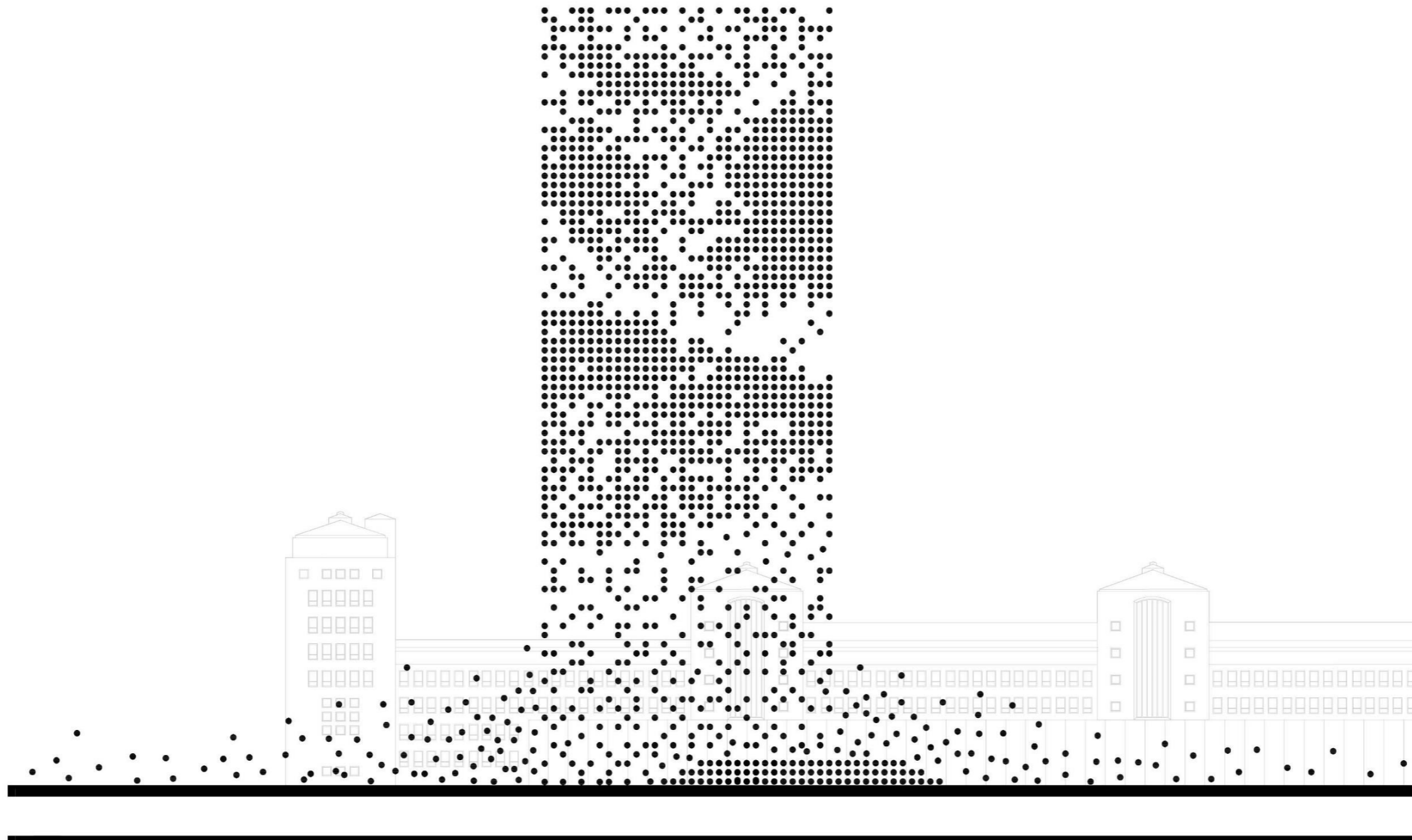

**Solid**

On campus, fixed and traditional

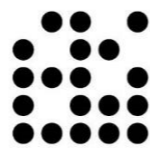

**Liquid**

On campus, flexible and interconnected



**Gas**

Off-campus, public domain

# Why a public base and an academical top?

To be efficiently solid-liquid-gas

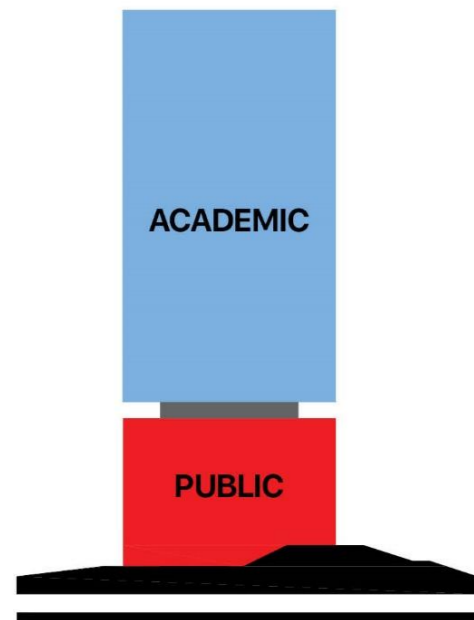

## Program mass

Base for everyone, Top for students

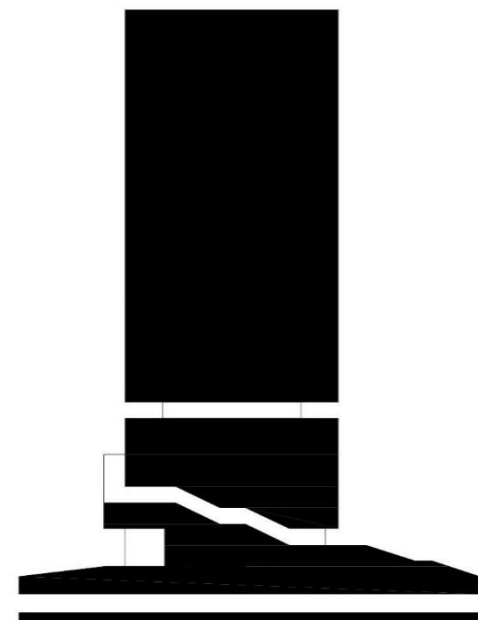

## Monolith

Mass of the vertical campus

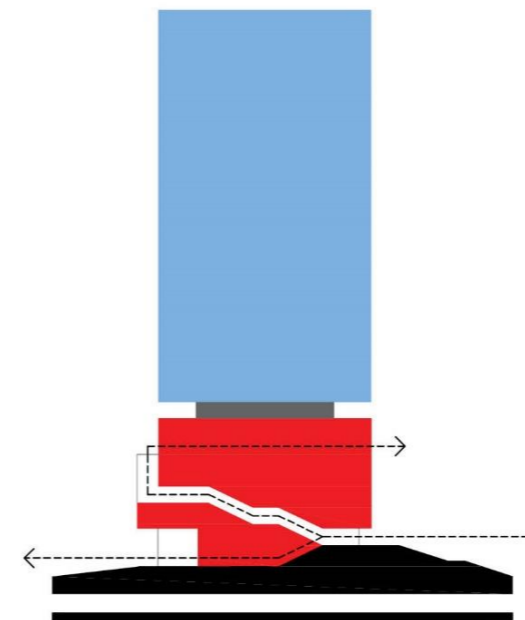

## Slice

Creating a passage and a climb

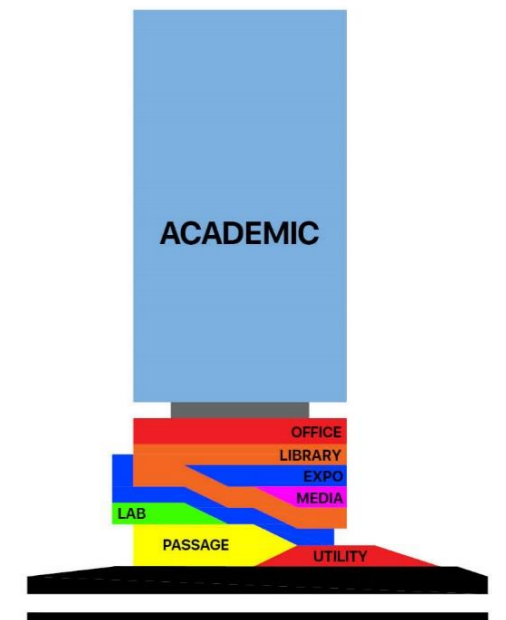

## Program

public vs semi private



**CID 'archipelago structures'**



**Marble mines**

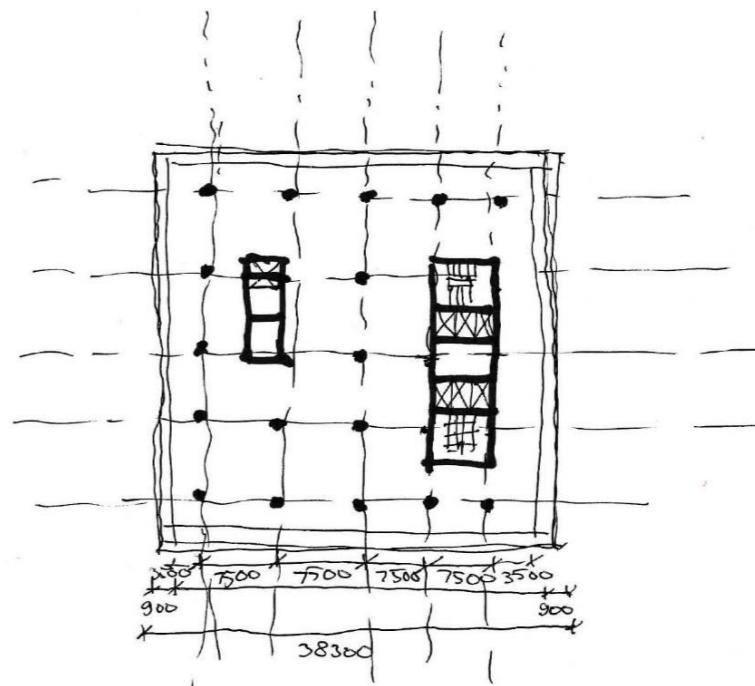
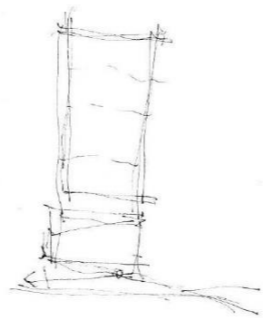
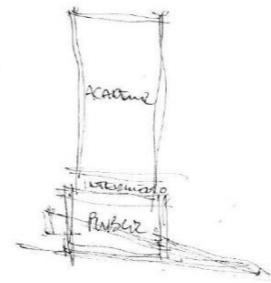

10,950 mm  
 27 BOUNDARY  
 BOOK STORAGE  
 READ AND STUDY  
 READ AND STUDY

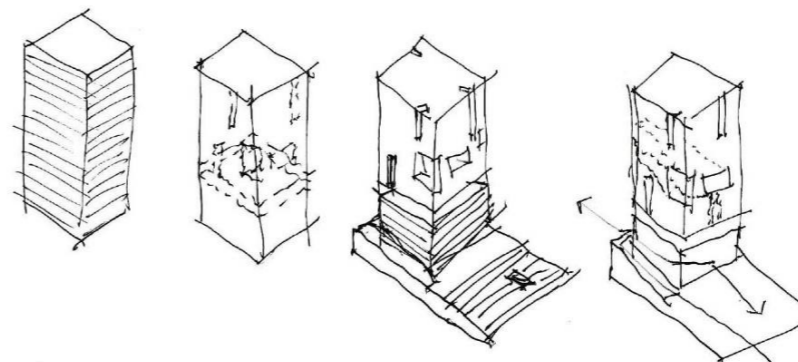
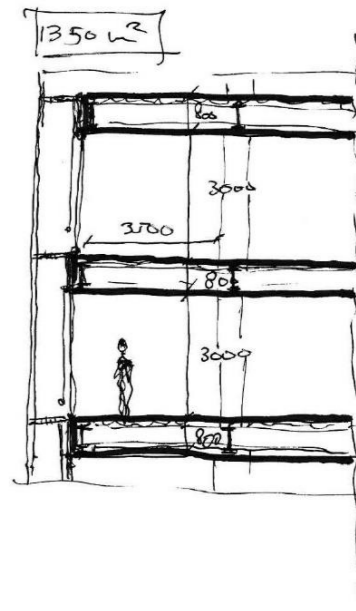







# How does the campus integrate?

Prins Clauslaan

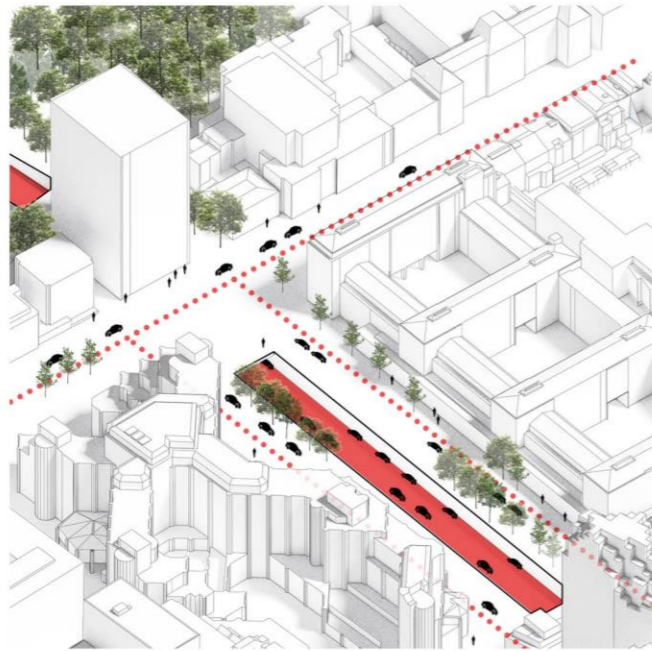

## Current Situation

Traffic around Prins Clauslaan

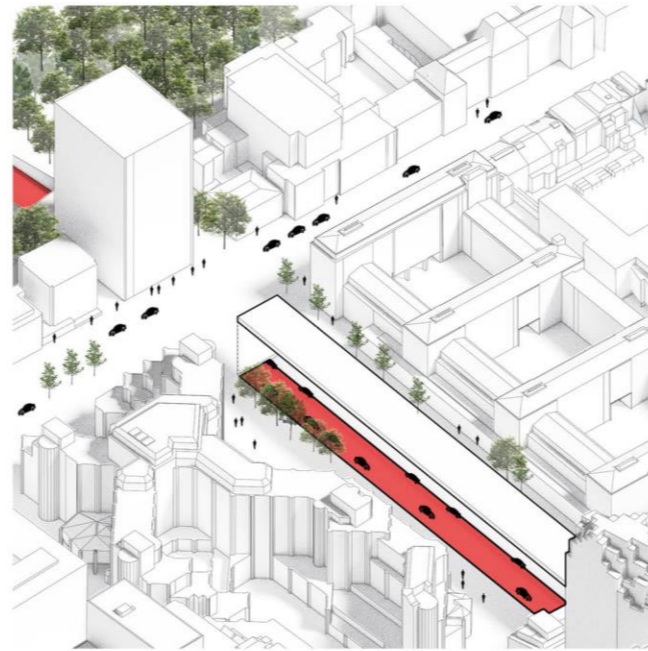

## Closing off the A12

Getting rid of an urban divider

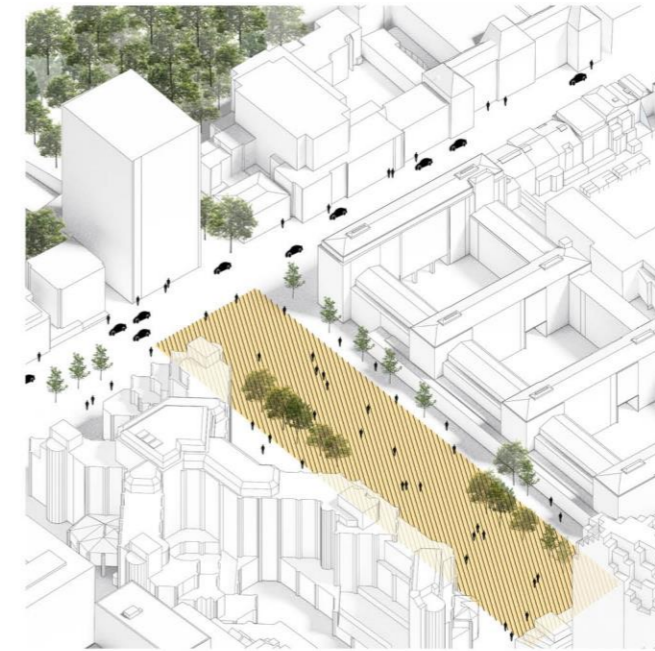

## Public Field

Connecting the landscape

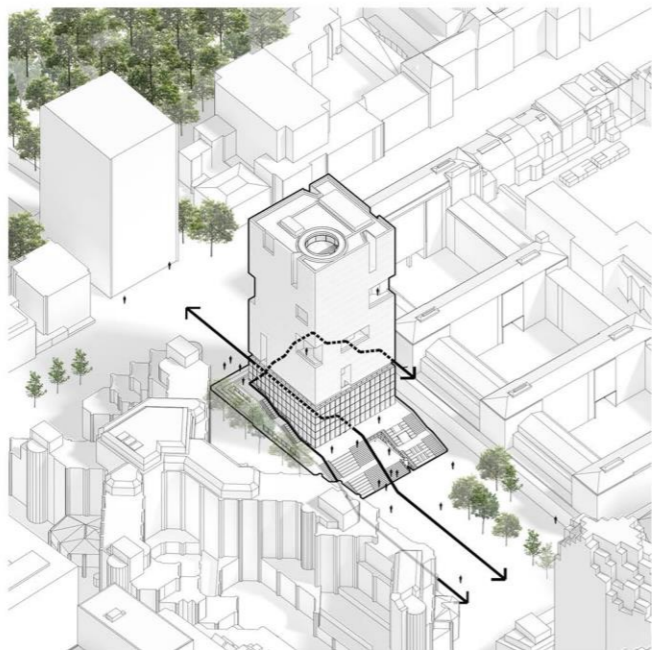

## Public passage

Creating a pathway underneath and up



## Connecting neighbourhoods

Connecting business and residential

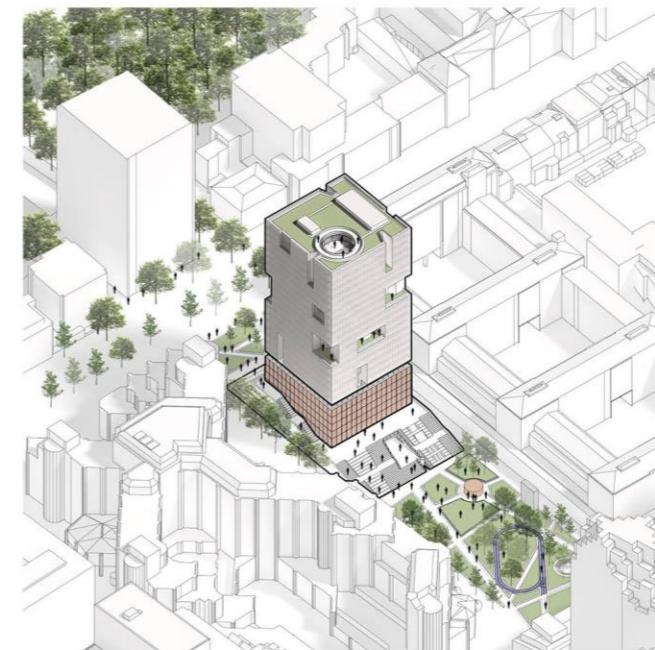

## Vertical Campus

A Public Condenser and Educational HUB

# Urban integration

Prins Clauslaan



# Overall concept

Appereance and circulation

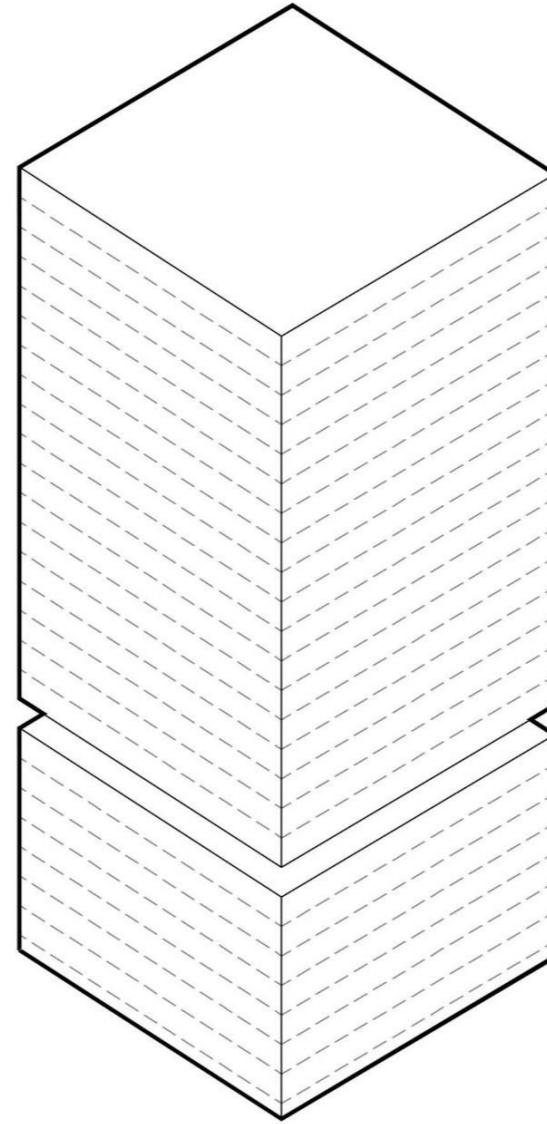

**Public base, academic top**  
30.000 m<sup>2</sup> to facilitate

# Overall concept

Appearance and circulation

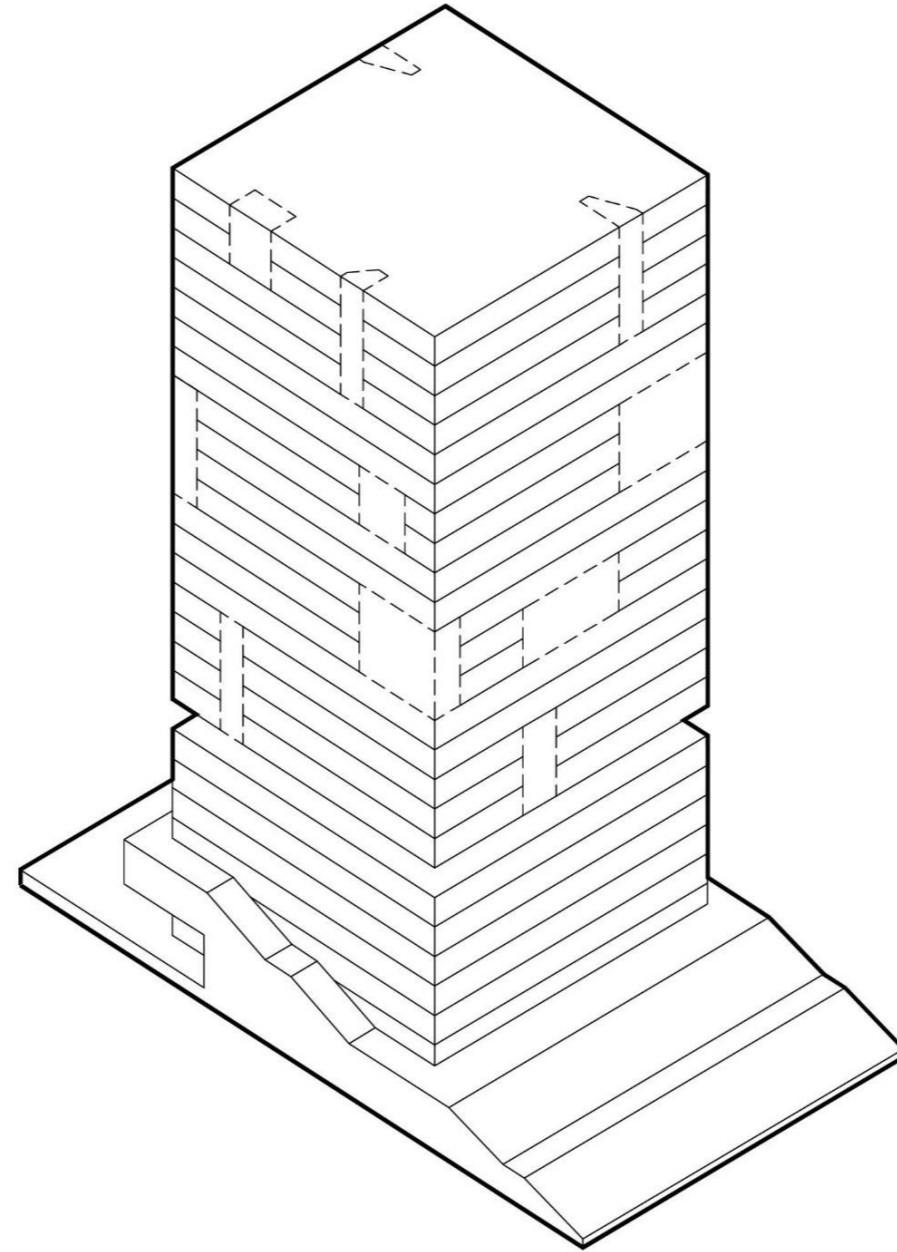

## Creating unique environments

To make the building dynamic

# Overall concept

Appearance and circulation

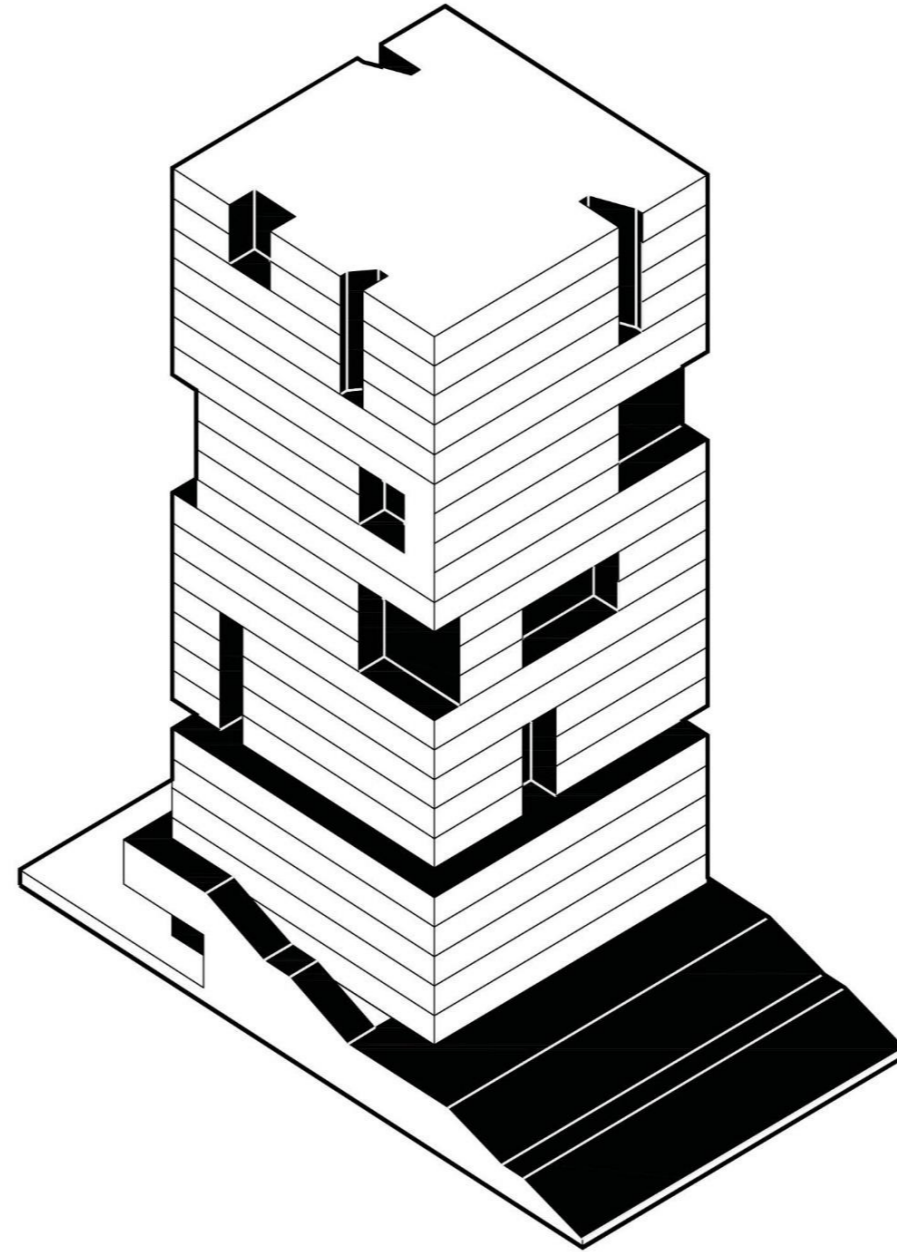

## Sculpting

Open and public spaces

# Overall concept

Apperance and circulation

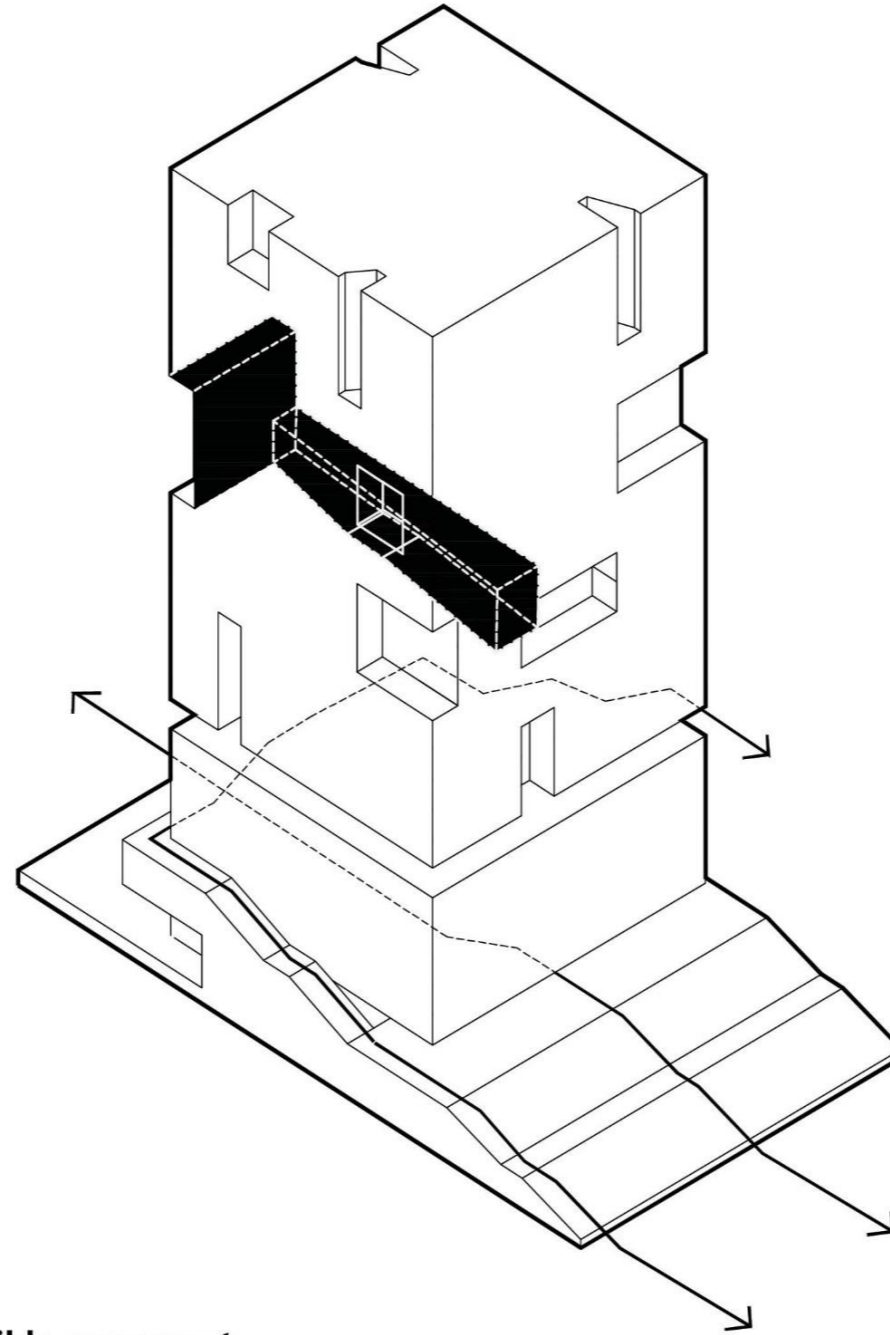

**Visible movement**  
Throughout the building

# Overall concept

Apperance and circulation

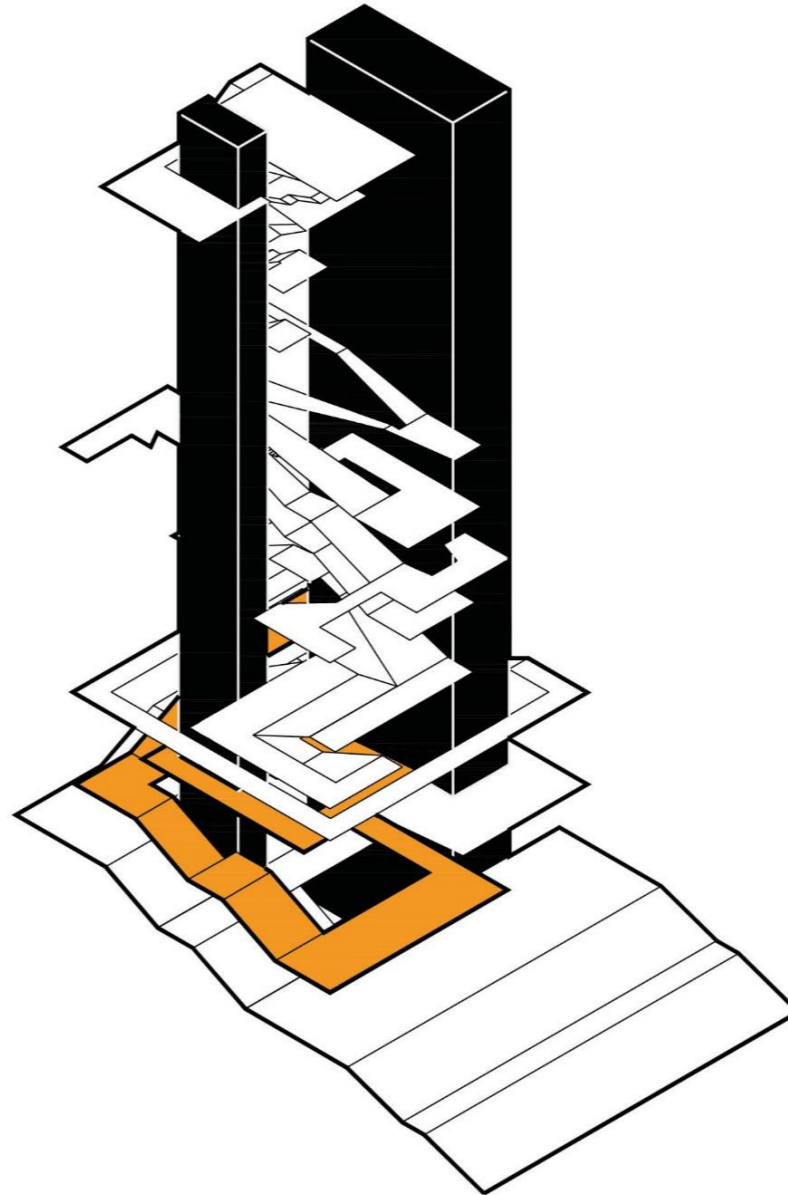

**Multiplicity in circulation**  
Connecting different layers

# Overall concept

Appearance and circulation

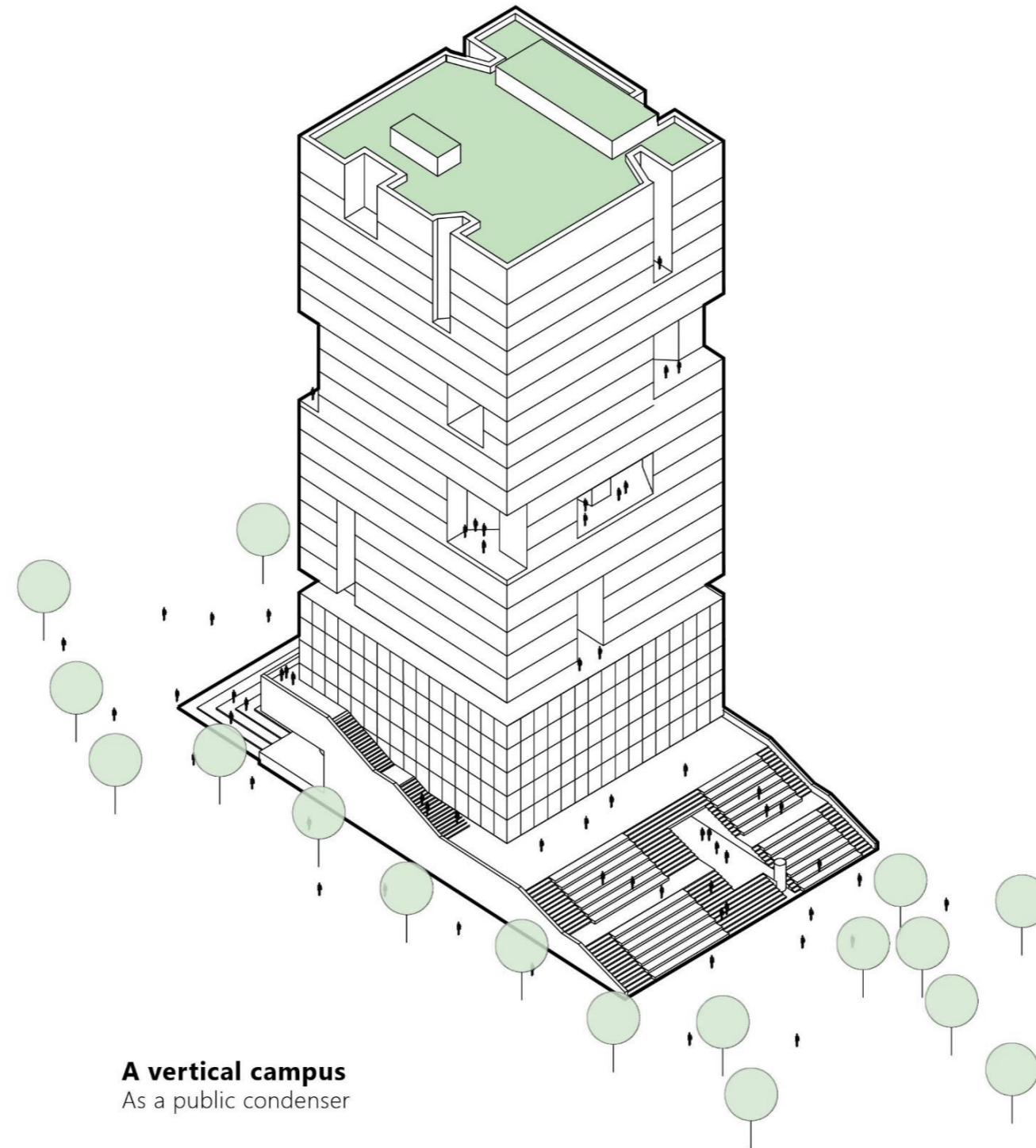

**A vertical campus**  
As a public condenser





# Program to floorplan

Basic grid

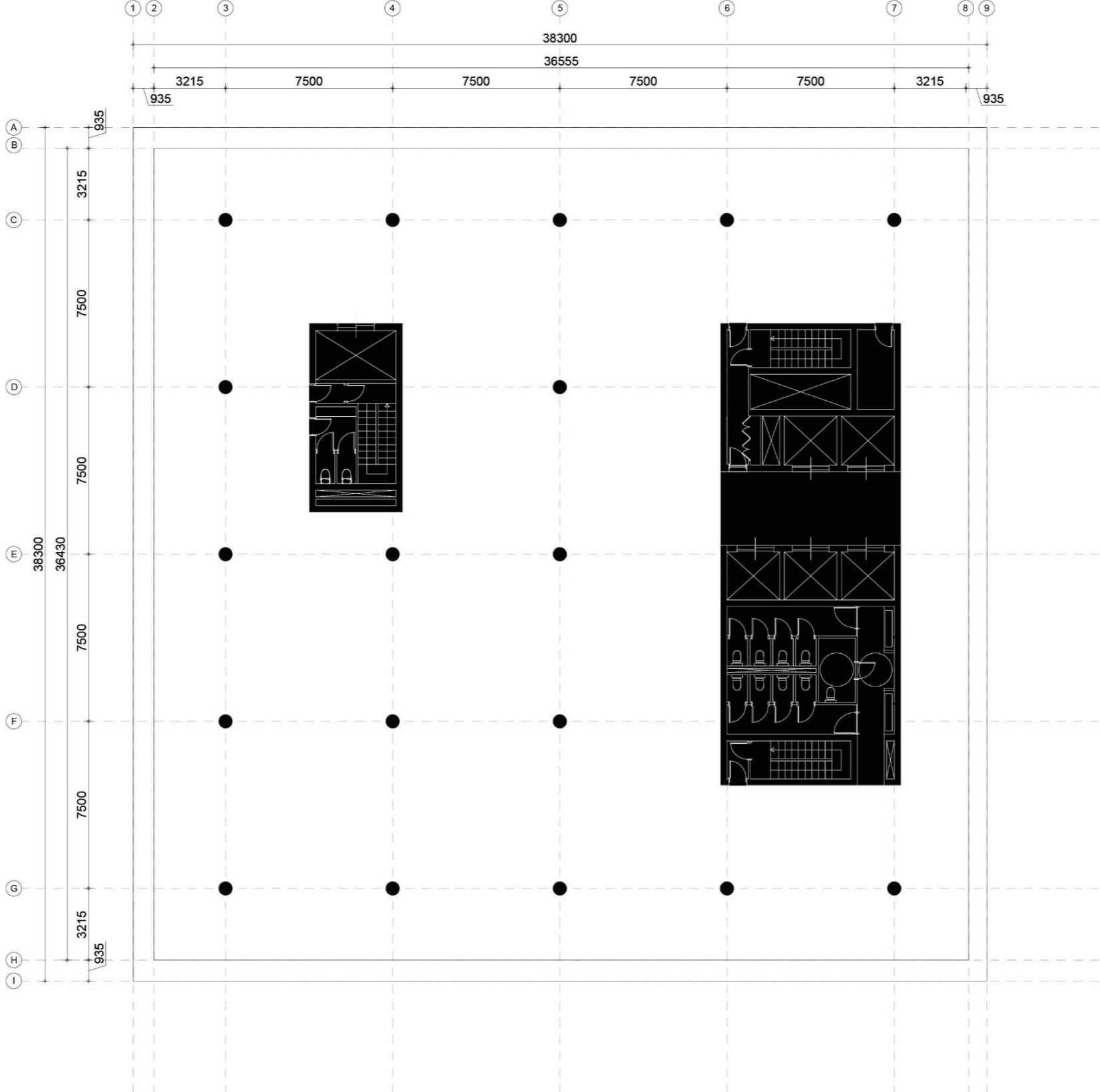

**Gross floor area**  
1336 m<sup>2</sup>  
**Net floor area**  
1061 m<sup>2</sup>

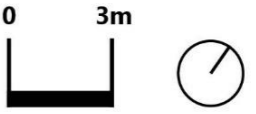

# Program to floorplan

Flexibility in spaces

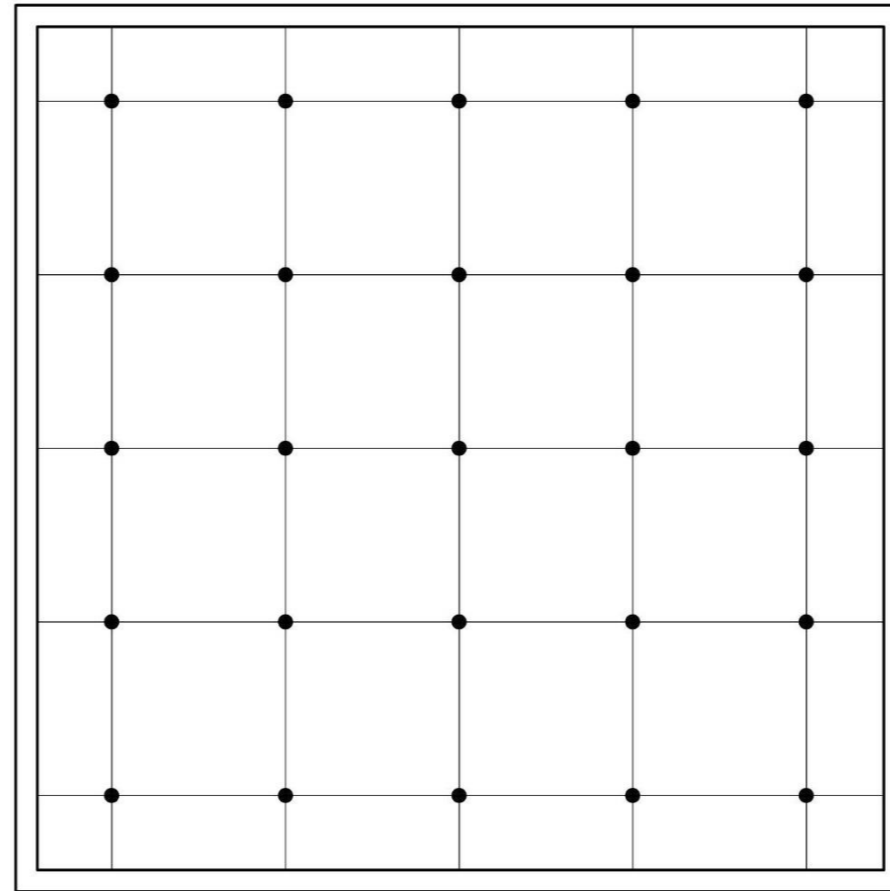

## Plan libre

Enables open, flexible layouts

# Program to floorplan

Flexibility in spaces

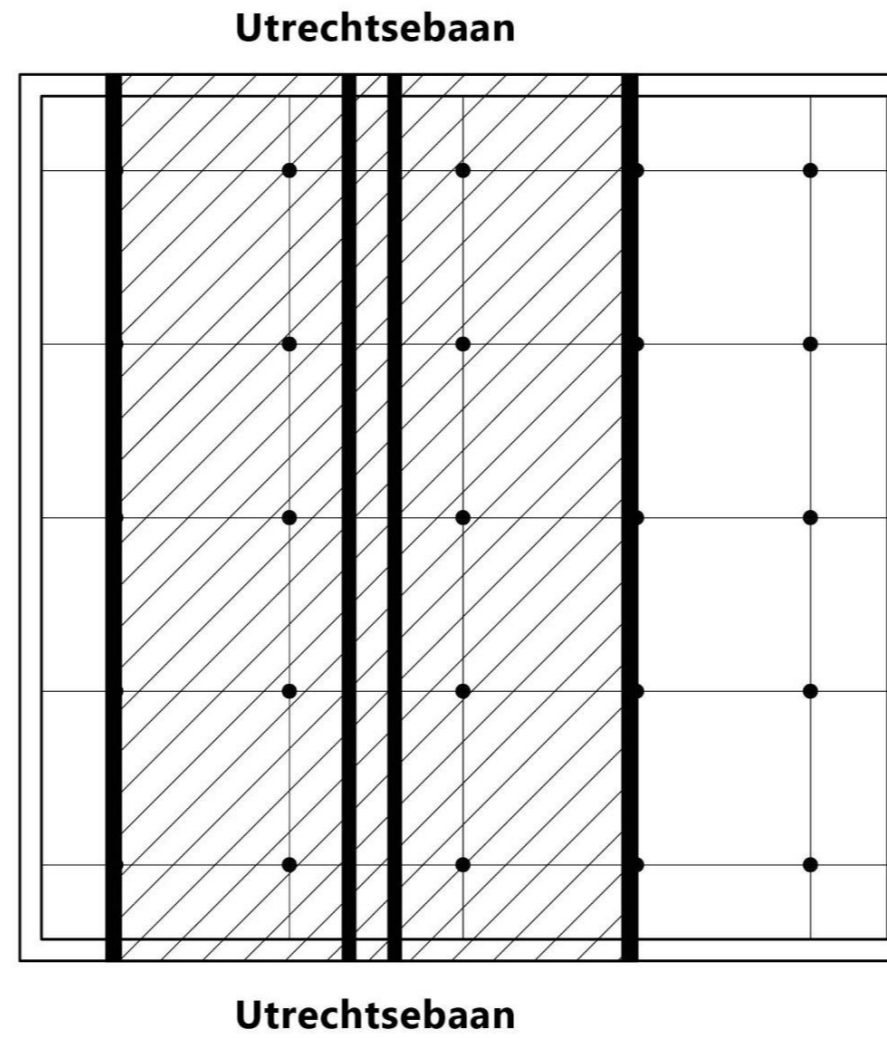

## Adapting to Utrechtsebaan

Aligned with the underground tunnel

# Program to floorplan

Flexibility in spaces

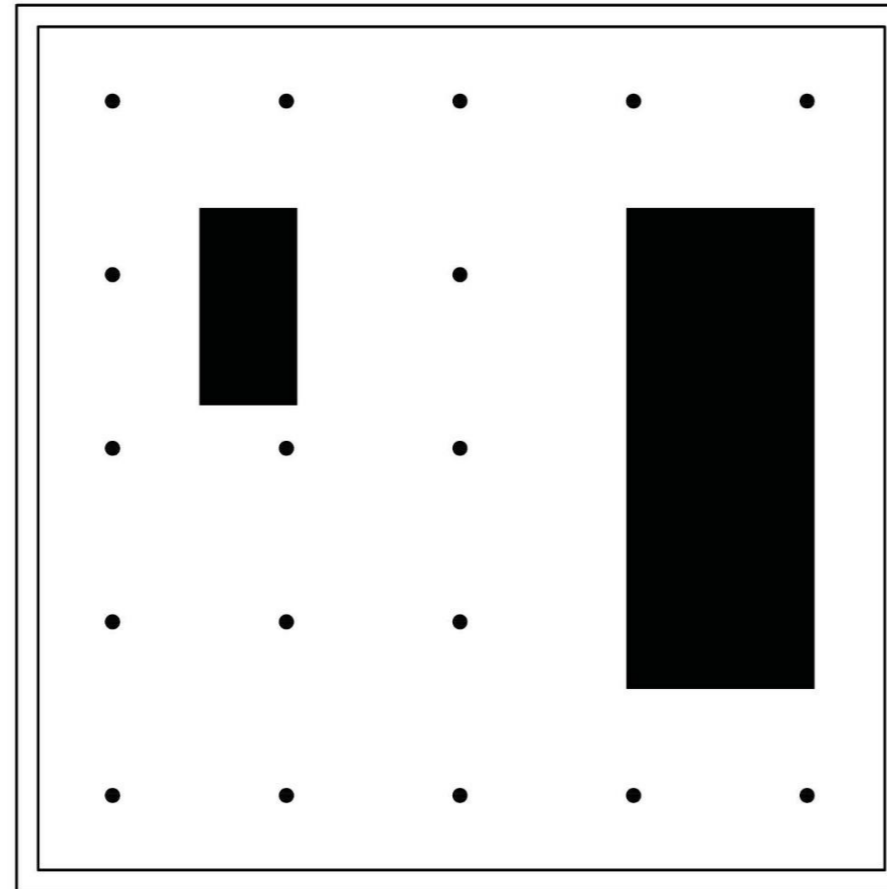

## Placing the cores

Strategic positioning alongside the Utrechtsebaan

# Program to floorplan

Flexibility in spaces

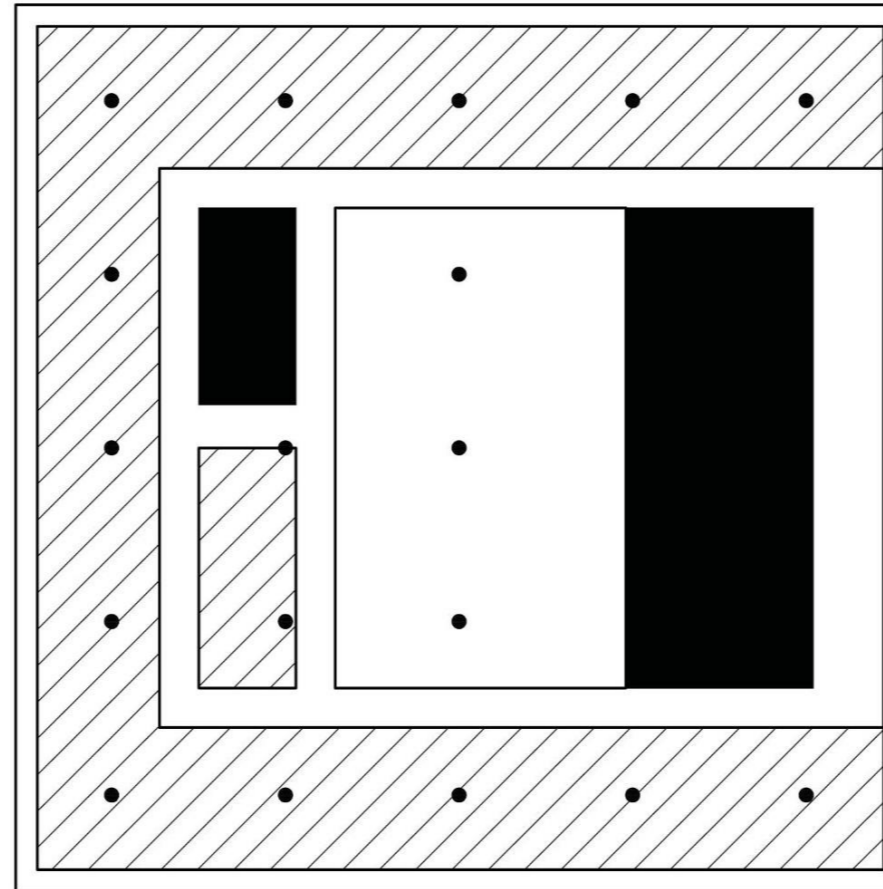

## Creating zones

To facilitate specific functions

# Program to floorplan

Flexibility in spaces

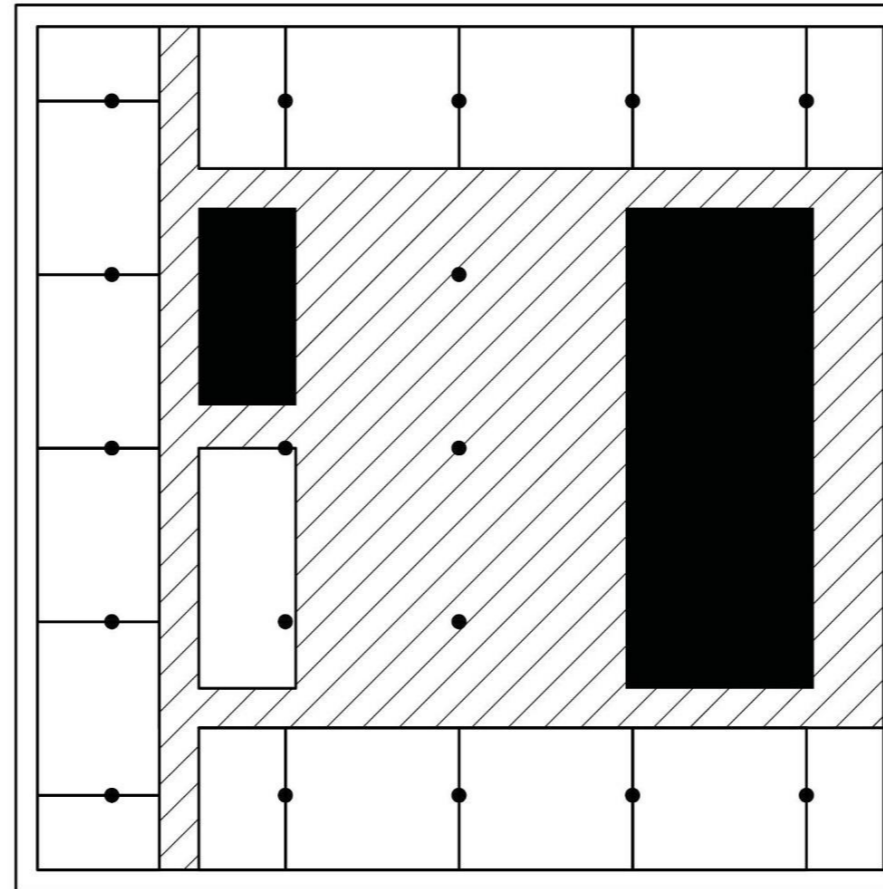

## Room placement

Divided into functional spaces

# Program to floorplan

Flexibility in spaces

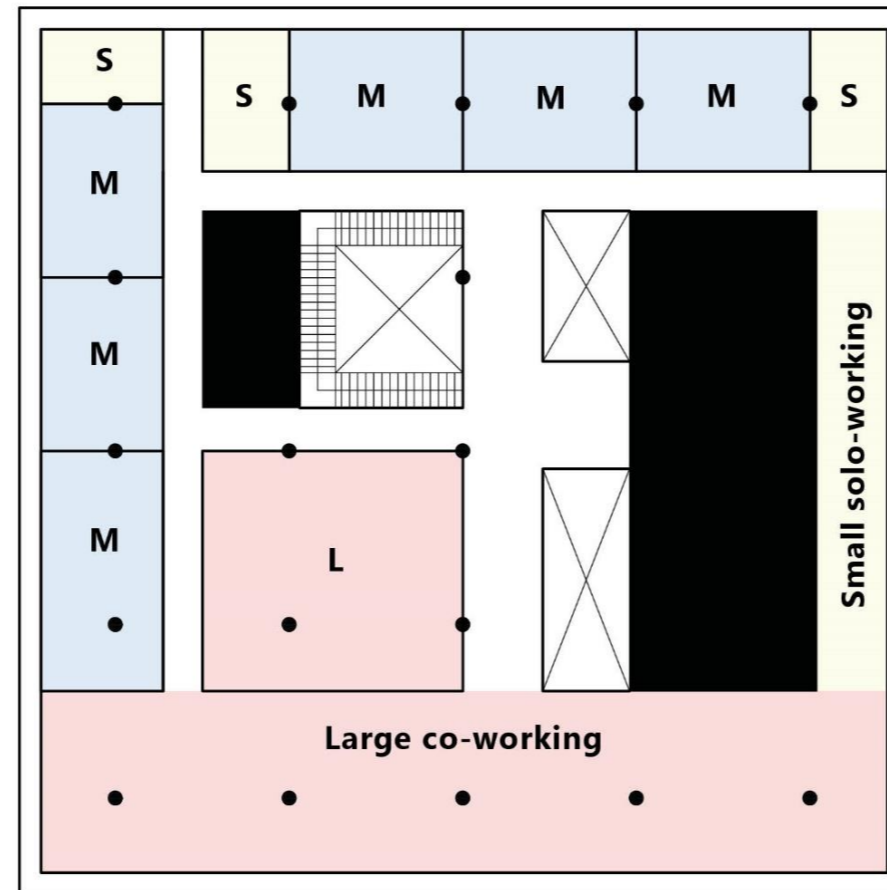

## Variations

Offering different configurations to adapt to user need





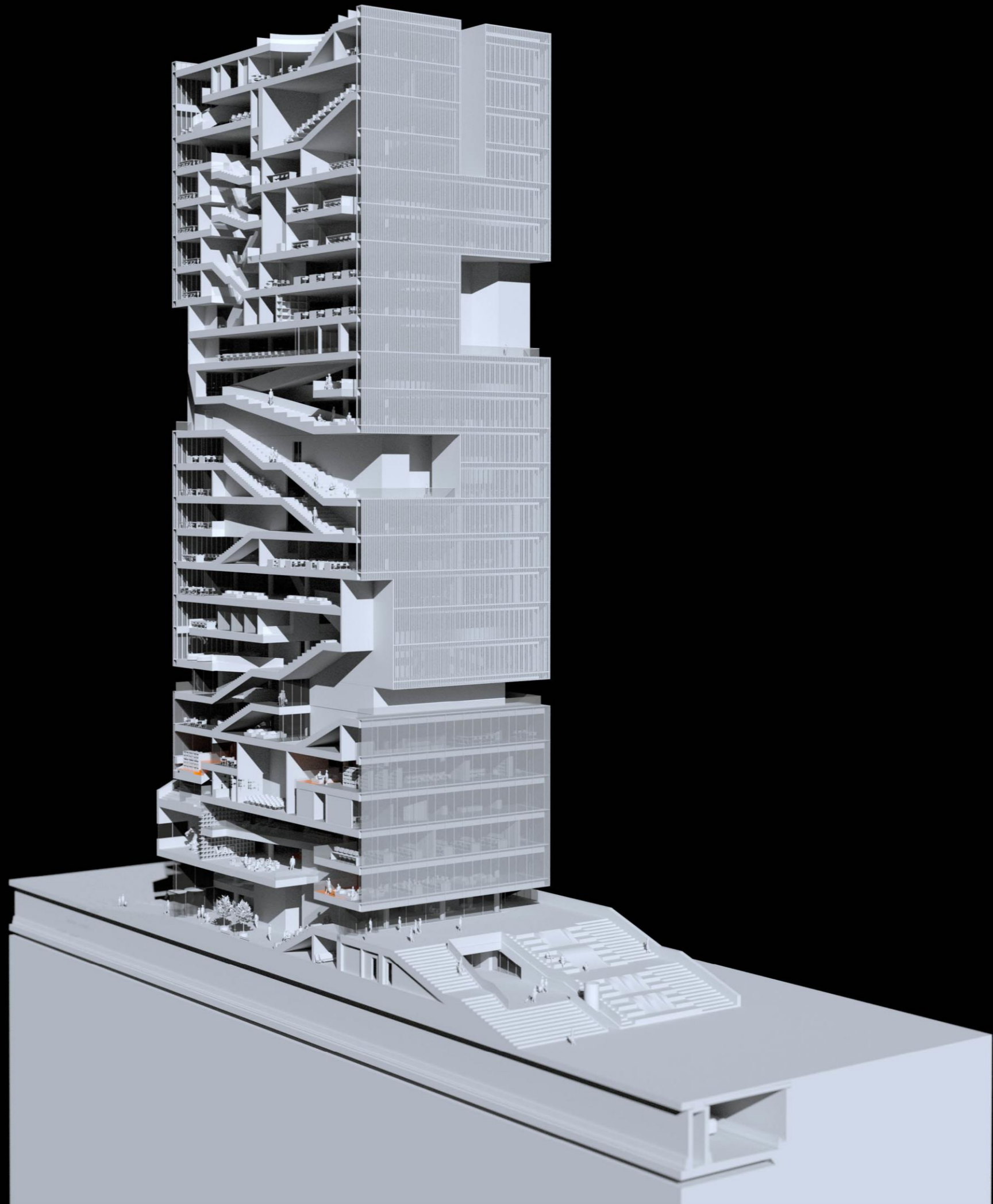

# Schematic program distribution

Solid-liquid-gas framework

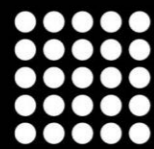
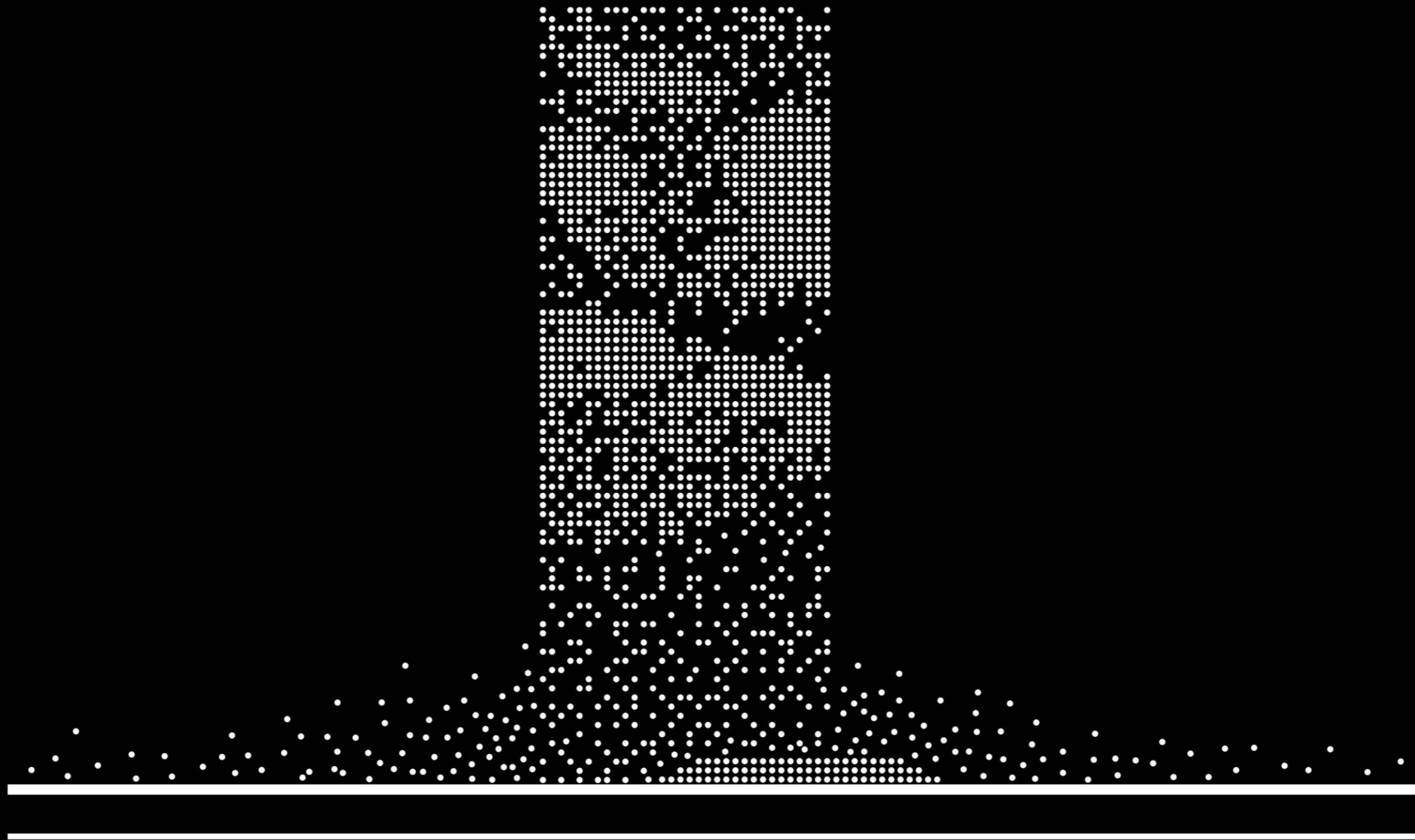

**Solid**

On campus, fixed and traditional

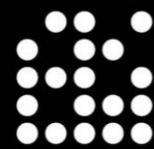

**Liquid**

On campus, flexible and interconnected

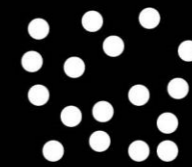

**Gas**

Off-campus, public domain

# Schematic program distribution

Program in elevation

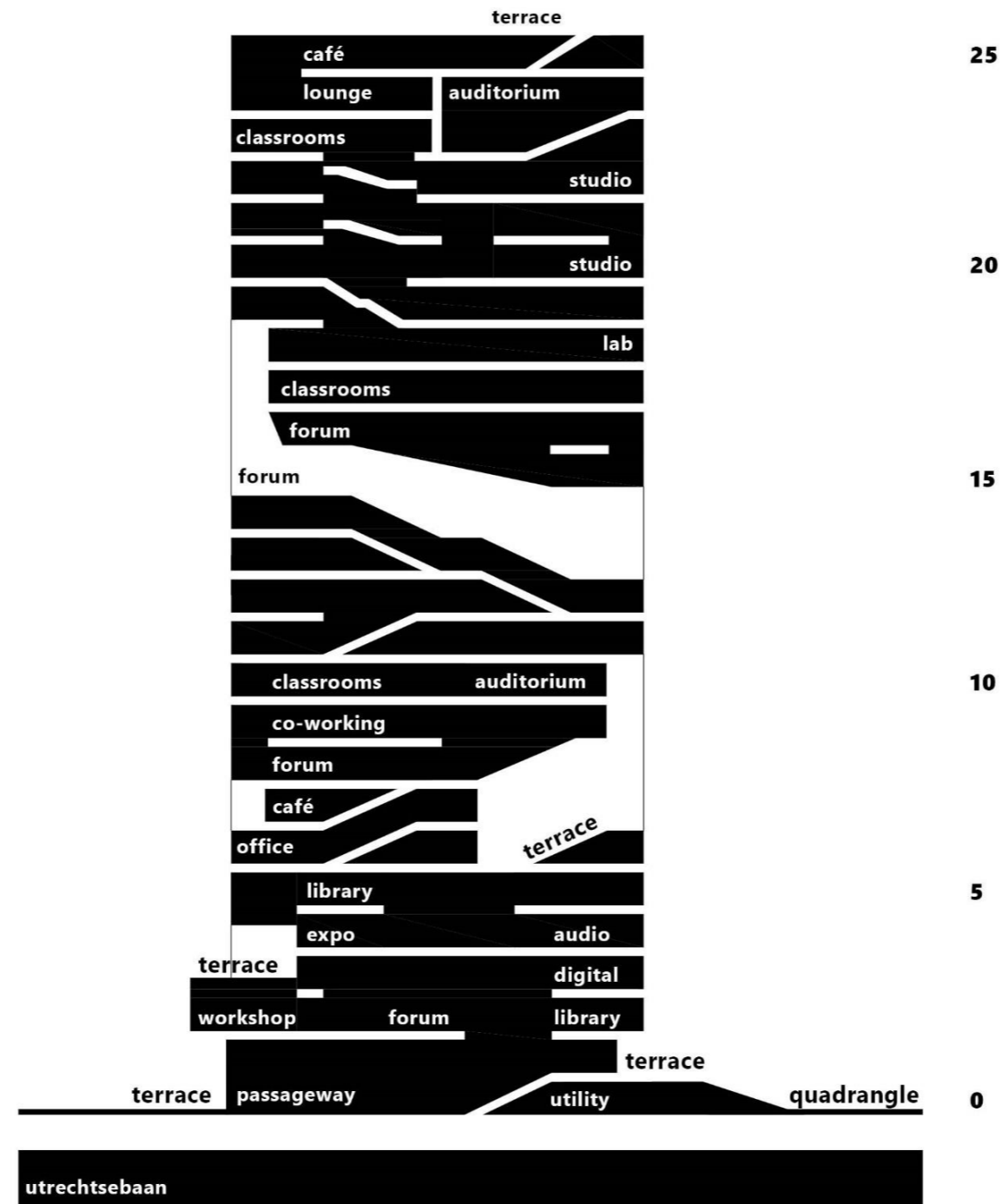

"The campus of the future is a combination of solid, liquid and gas".

"The challenge for the campus of the future remains the same: How do we accommodate the traditional, connected and virtual campus - solid, liquid and gas - and in which combination? This question should be answered for all function types on campus, ranging from educational spaces and research space to office space and support functions like restaurants, student housing, sports facilities etc."

Alexandra den Heijer in 'Campus of the future' (2023)

# Multiplicity in circulation

A vertical journey through campus

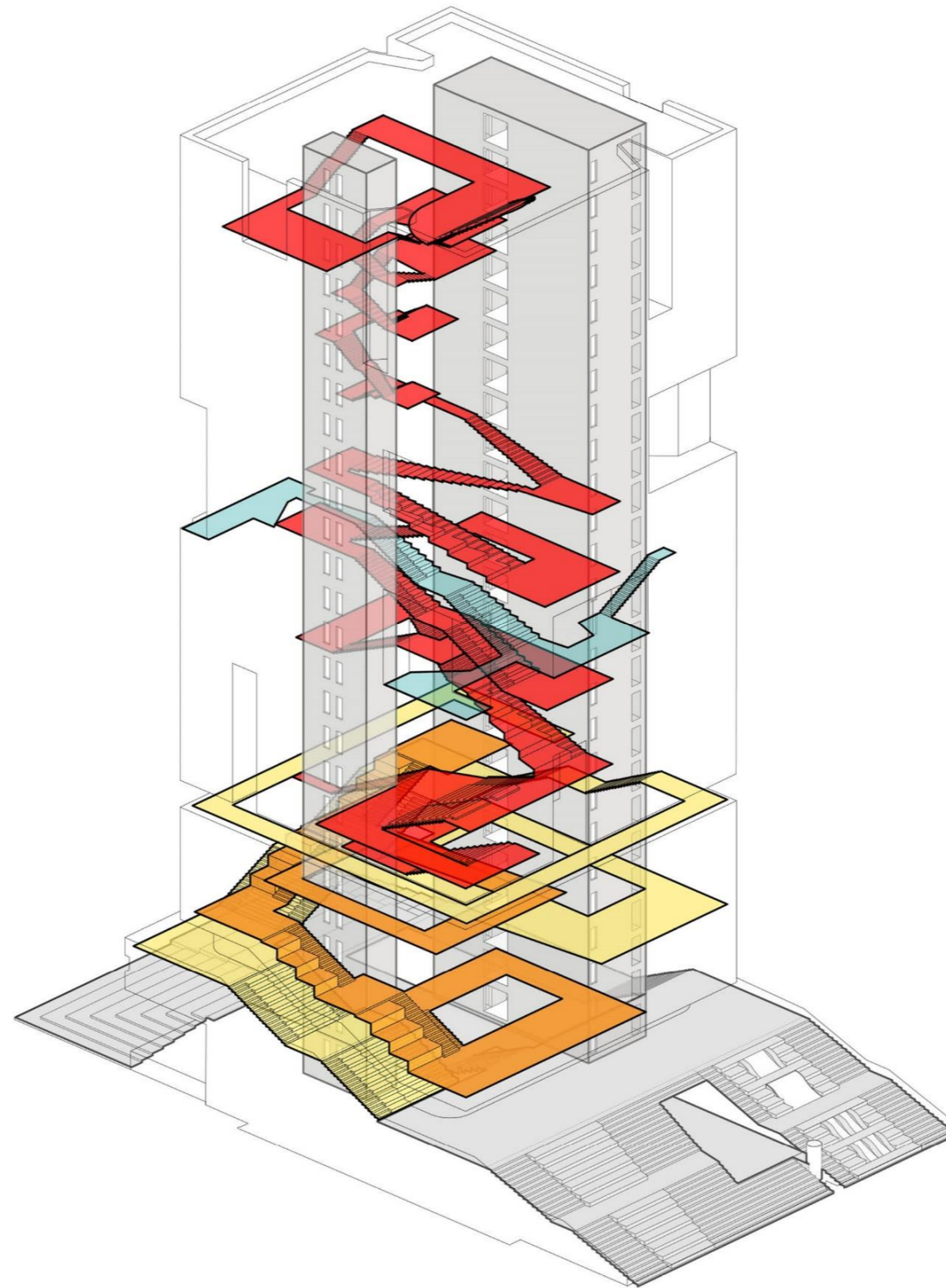

**00-25** Fast route

**13-15** Upper outdoor route

**08-25** Academical route

**02-05** Library route

**01-04** Exhibition route

**00-01** Passage

# Multiplicity in circulation

A vertical journey through campus

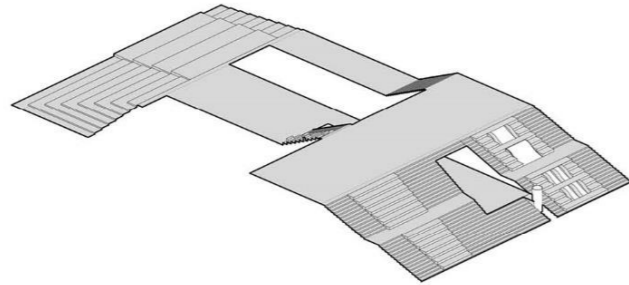

**Passage**  
Connection to the outside

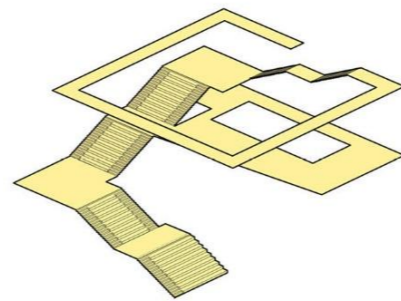

**Exhibition route**  
Public exhibitions

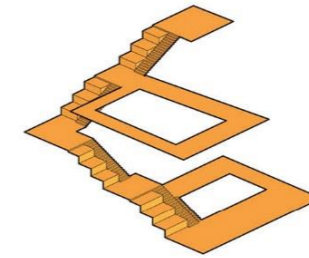

**Library route**  
Public library



**Academical route**  
Connecting different educational spaces

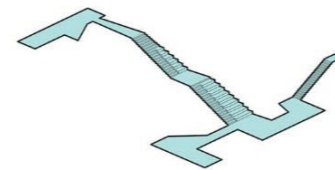

**Upper outdoor route**  
Outside space to interact

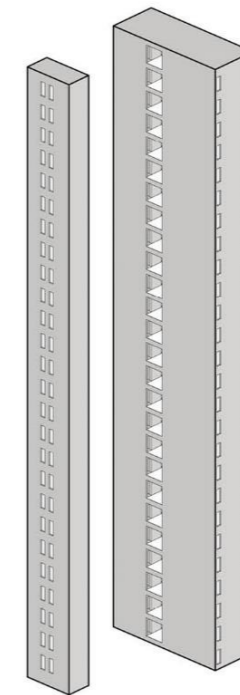

**Fast route**  
Fast to public/academic destination

# Floor plans

Ground floor

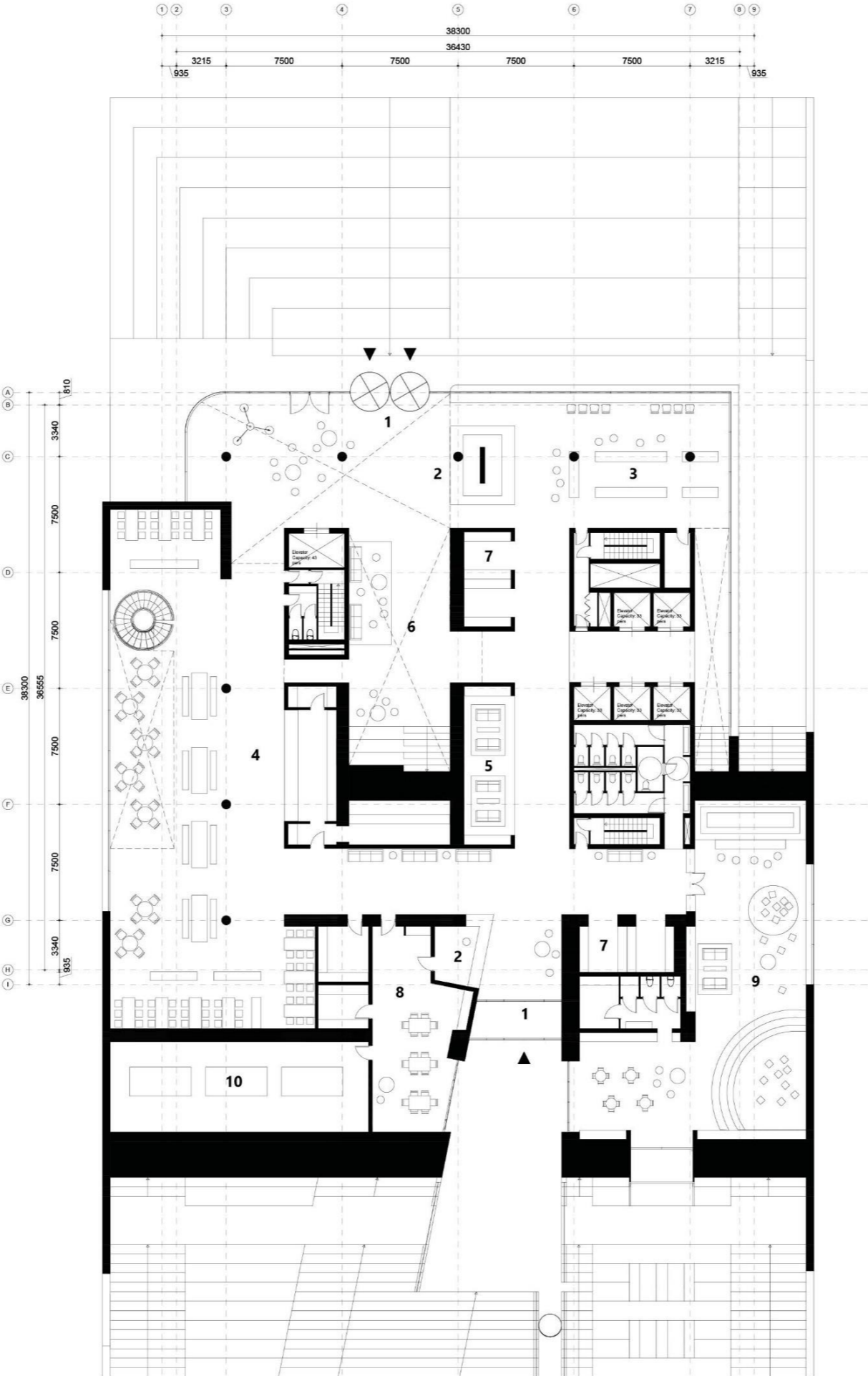

- 1 entrance
- 2 reception
- 3 studentshop
- 4 café
- 5 lounge
- 6 passage
- 7 lockers
- 8 office
- 9 daycare HUB
- 10 technical room



# Floor plans

Ground floor





# Floor plans

## Passage

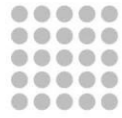

**Solid**  
On campus, fixed space

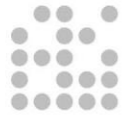

**Liquid**  
On campus, flexible space



**Gas**  
Off-campus, for everyone

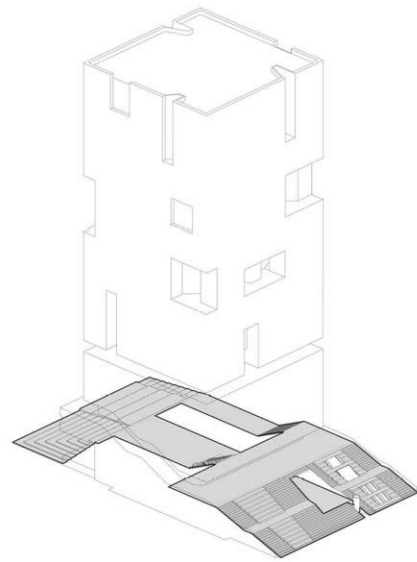

**Passage**  
Connection to the outside



# Floor plans

## Passage

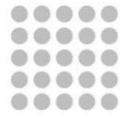

**Solid**  
On campus, fixed space



**Liquid**  
On campus, flexible space



**Gas**  
Off-campus, for everyone

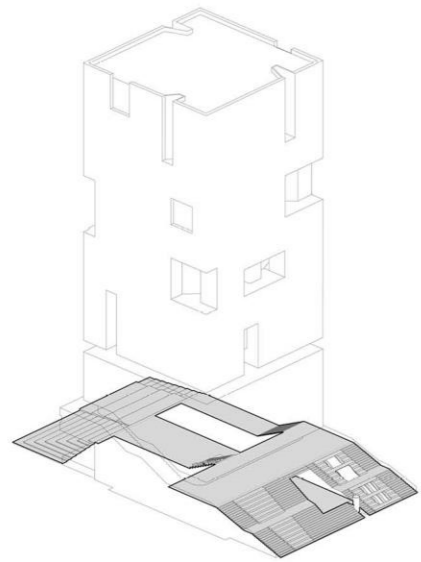

**Passage**  
Connection to the outside



# Floor plans

## Passage

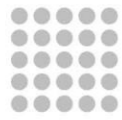

**Solid**  
On campus, fixed space

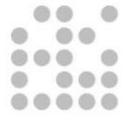

**Liquid**  
On campus, flexible space

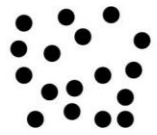

**Gas**  
Off-campus, for everyone

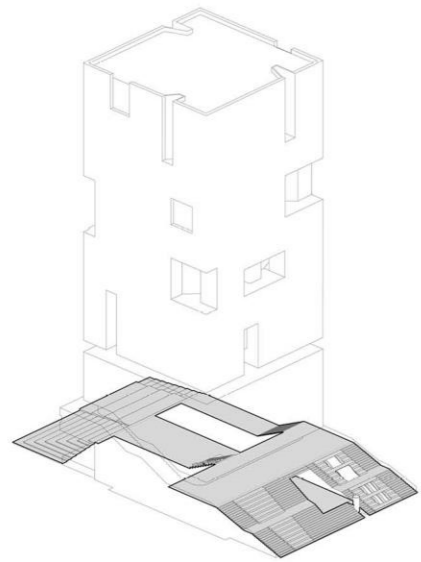

**Passage**  
Connection to the outside



# Floor plans

Café/restaurant

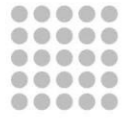

**Solid**  
On campus, fixed space

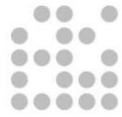

**Liquid**  
On campus, flexible space

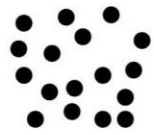

**Gas**  
Off-campus, for everyone

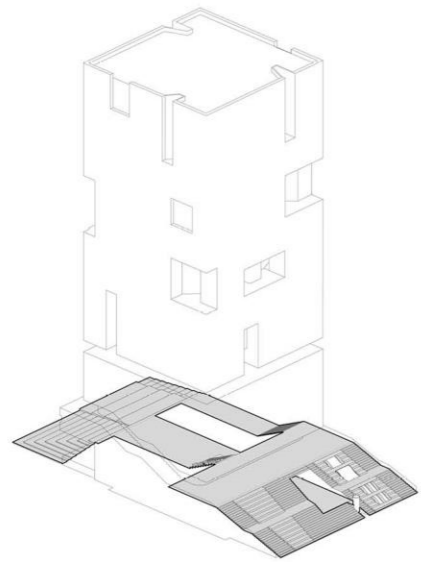

**Passage**  
Connection to the outside



# Floor plans

Ground floor



# Floor plans

First floor



# Floor plans

Second floor



# Floor plans

Tech-lab/Workshop

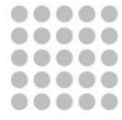

**Solid**

On campus, fixed space



**Liquid**

On campus, flexible space



**Gas**

Off-campus, for everyone

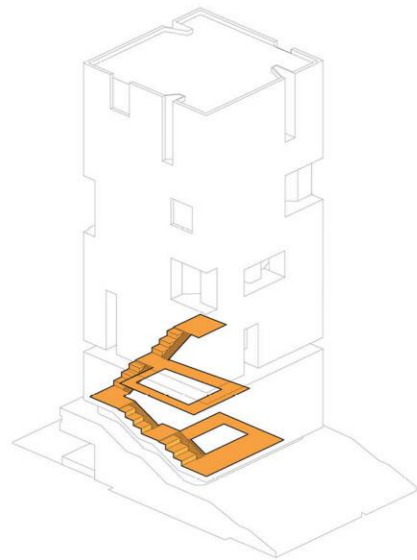

**Library route**

Public library





# Floor plans

Library

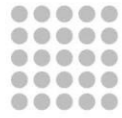

**Solid**  
On campus, fixed space



**Liquid**  
On campus, flexible space



**Gas**  
Off-campus, for everyone

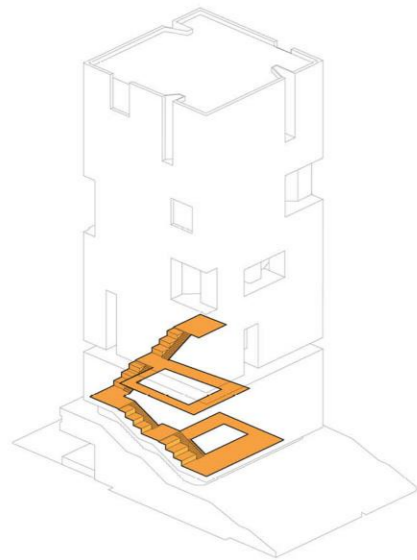

**Library route**  
Public library



# Floor plans

Second floor



# Floor plans

Third floor

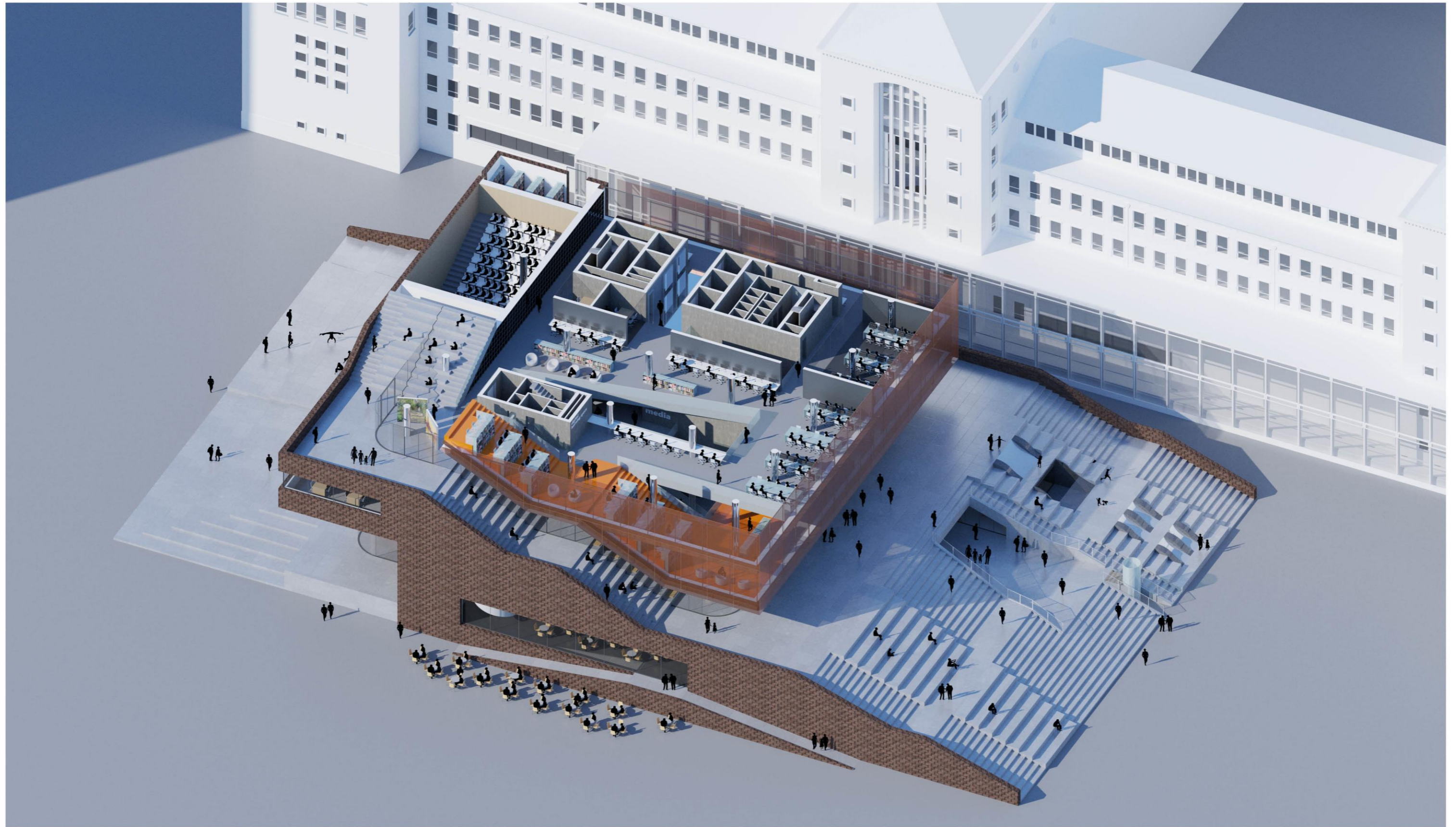

# Floor plans

Fourth floor

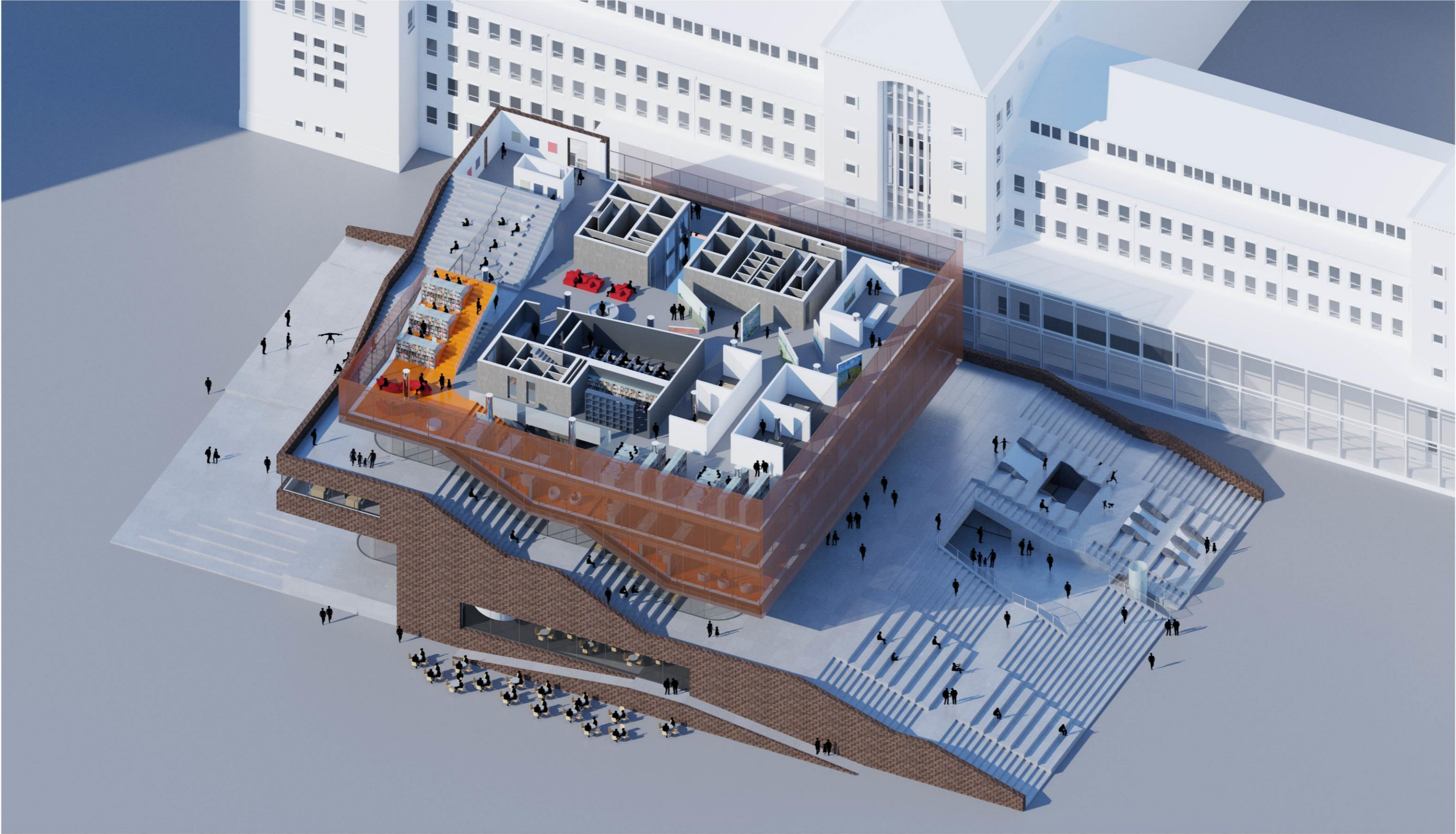

# Floor plans

Fifth floor

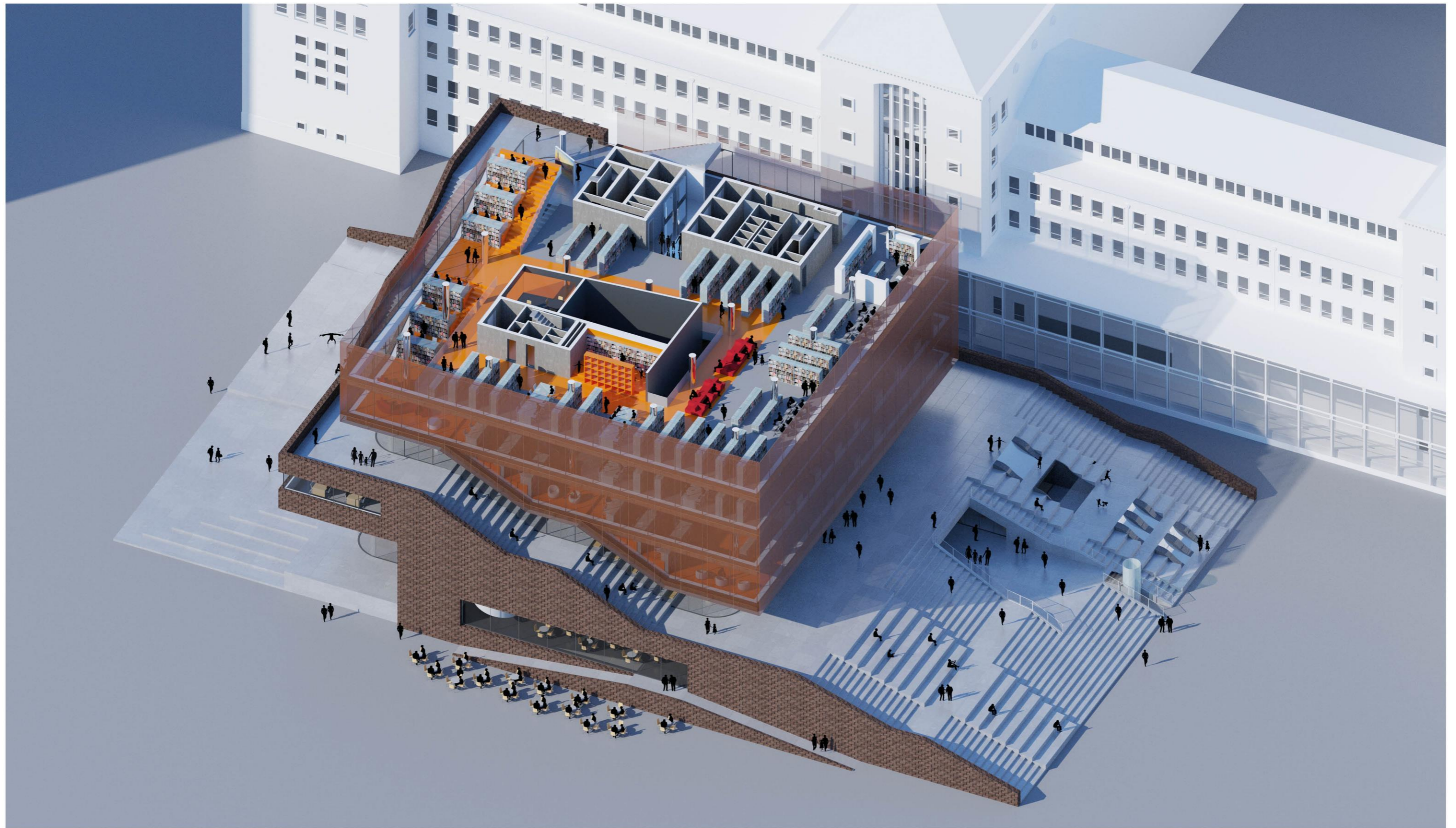

# Floor plans

Sixth floor

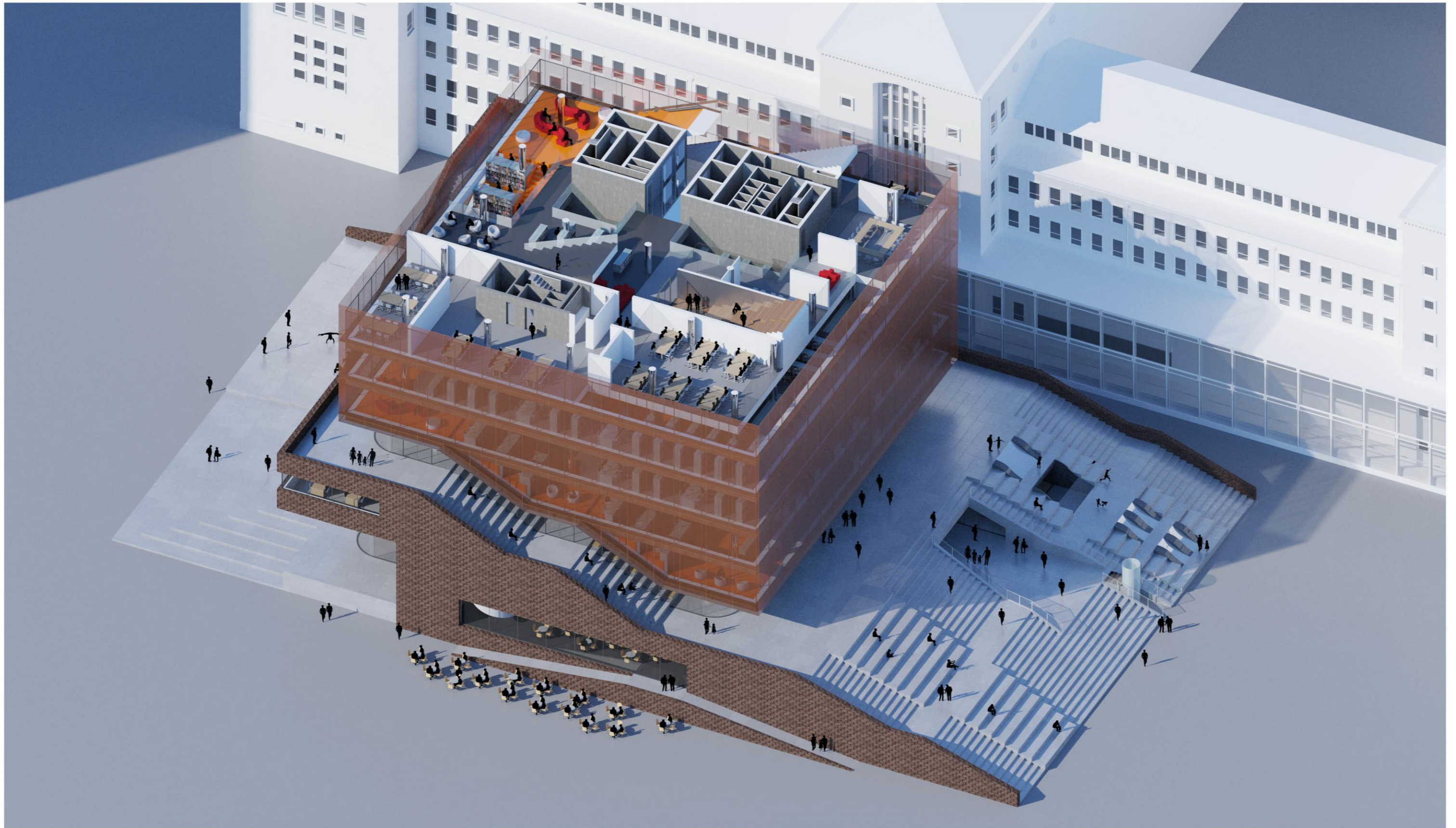

# Floor plans

Seventh floor

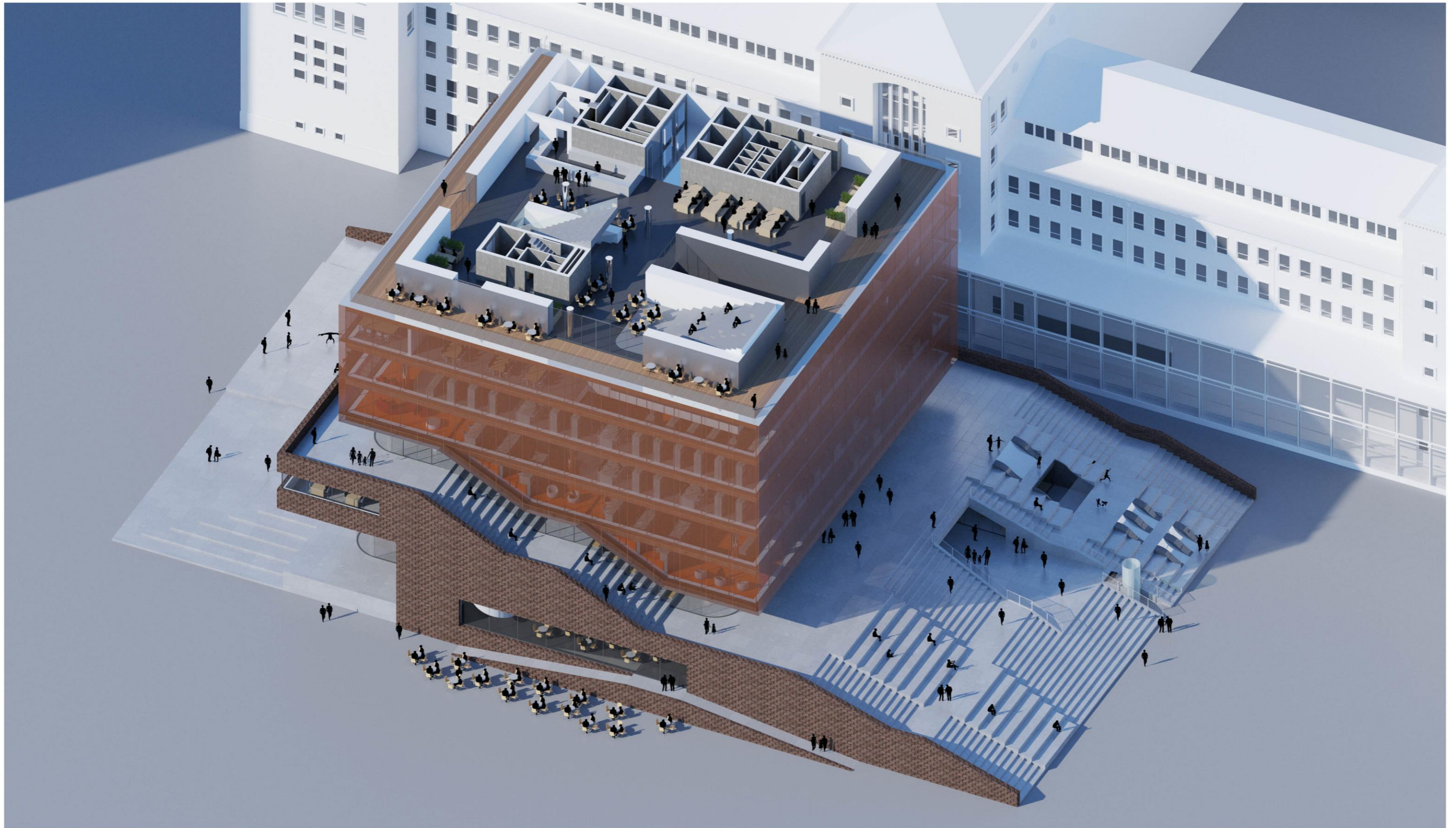

# Floor plans

Base in context





# Floor plans

Twelfth floor

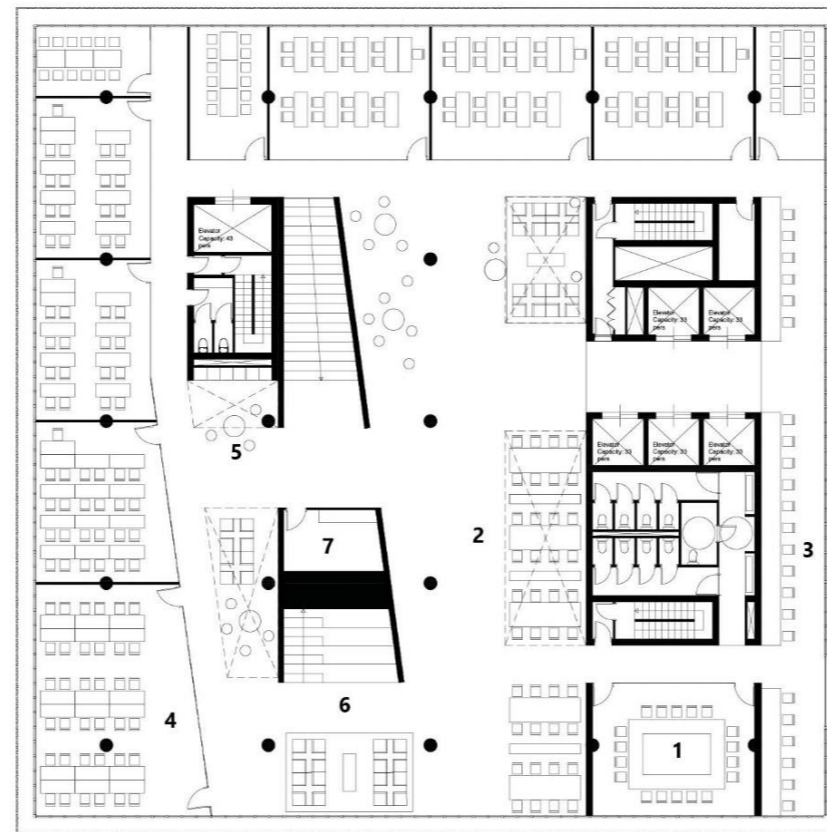

- 1 meeting room
- 2 collaborative study space
- 3 solo study space
- 4 classroom
- 5 coffee corner
- 6 lounge/forum
- 7 storage

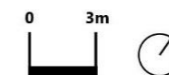

# Floor plans

Start academical route

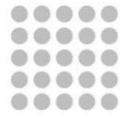

**Solid**  
On campus, fixed space

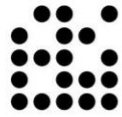

**Liquid**  
On campus, flexible space



**Gas**  
Off-campus, for everyone

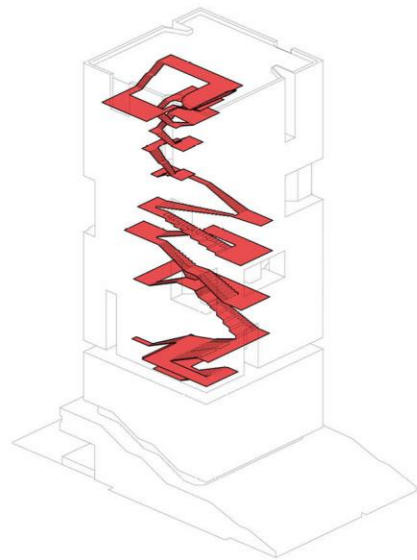

**Academical route**

Connecting different educational spaces



# Floor plans

Breakoutroom auditorium

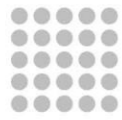

**Solid**  
On campus, fixed space

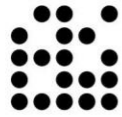

**Liquid**  
On campus, flexible space



**Gas**  
Off-campus, for everyone

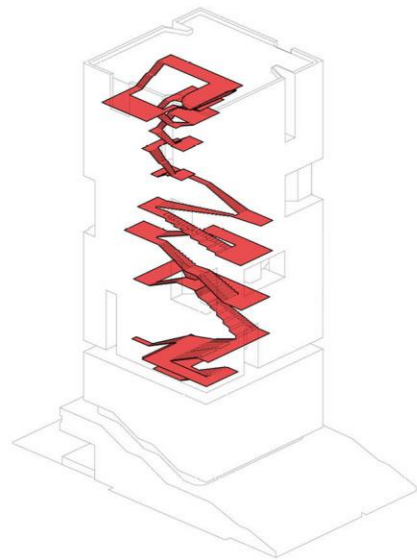

**Academical route**

Connecting different educational spaces



# Floor plans

Typical classroom

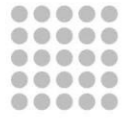

**Solid**  
On campus, fixed space

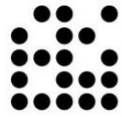

**Liquid**  
On campus, flexible space



**Gas**  
Off-campus, for everyone

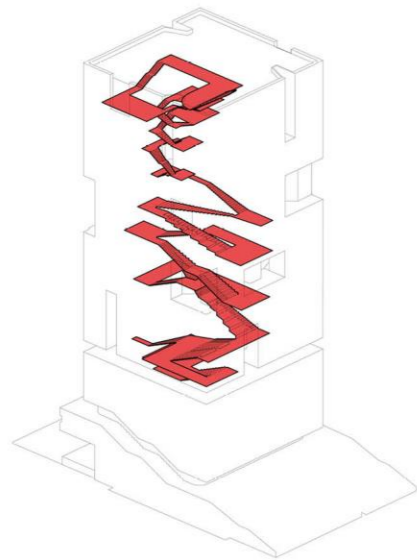

**Academical route**

Connecting different educational spaces



# Floor plans

Typical classroom

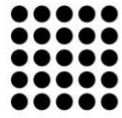

**Solid**

On campus, fixed space



**Liquid**

On campus, flexible space



**Gas**

Off-campus, for everyone

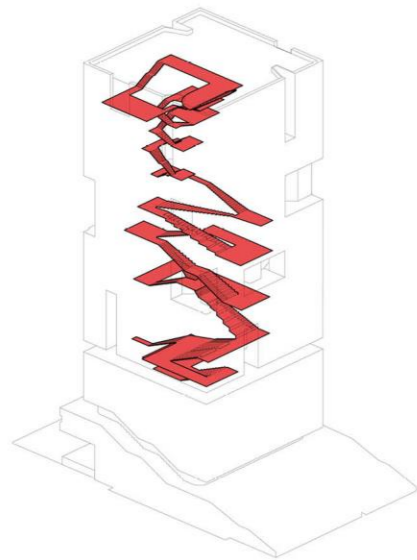

**Academical route**

Connecting different educational spaces



# Floor plans

Flexibility in classrooms

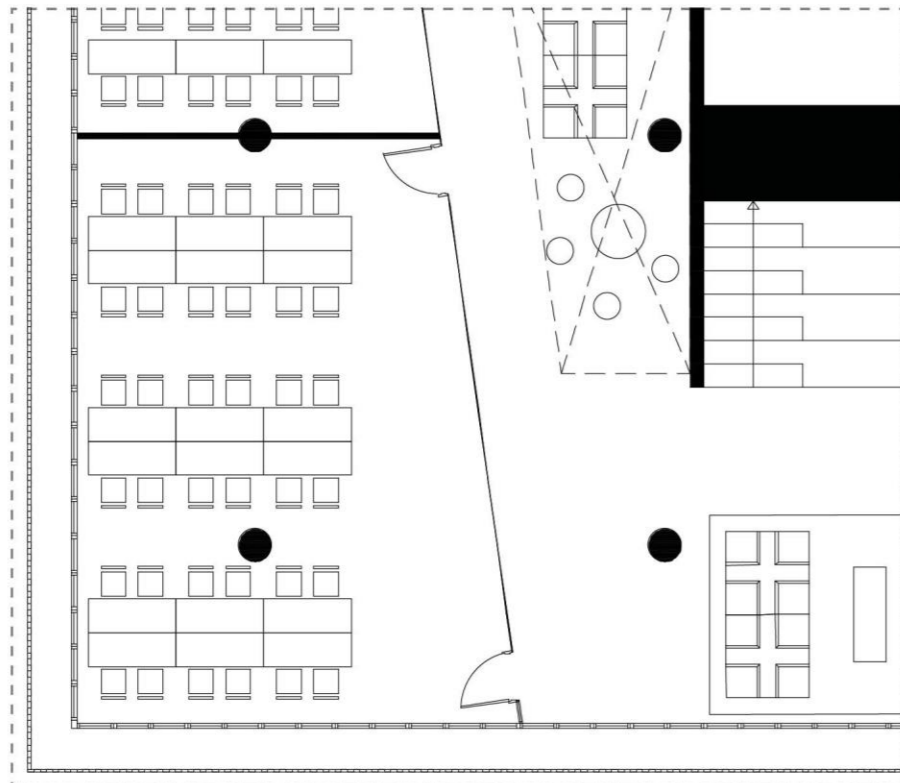

Closed classroom



Closed classroom

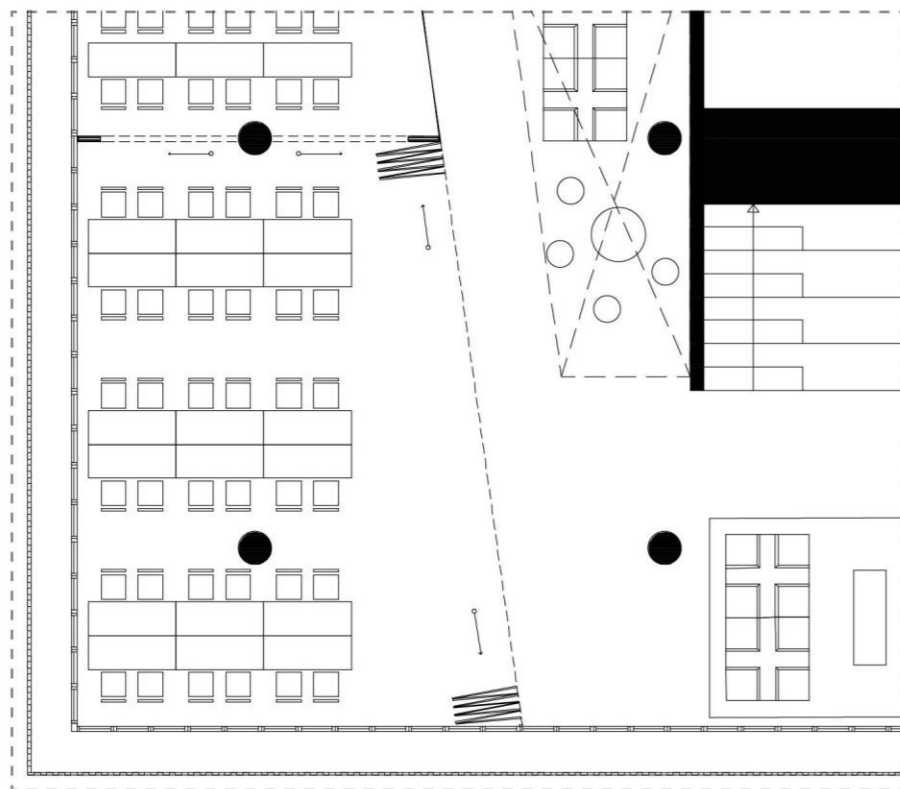

Opened classroom



Opened classroom

# Floor plans

Outside forums

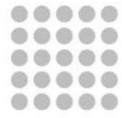

**Solid**  
On campus, fixed space

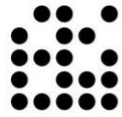

**Liquid**  
On campus, flexible space



**Gas**  
Off-campus, for everyone

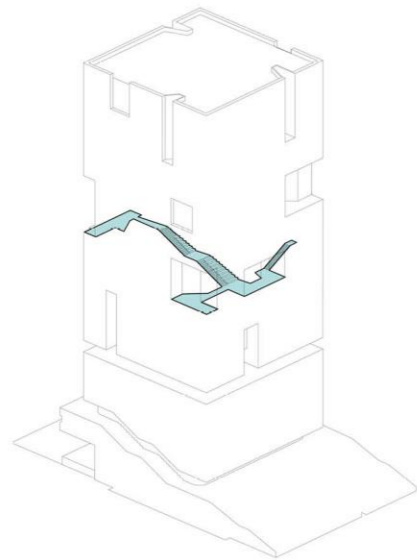

**Upper outdoor route**

Outside space to interact



# Floor plans

Connecting studio's

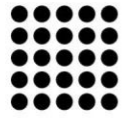

**Solid**

On campus, fixed space

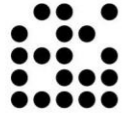

**Liquid**

On campus, flexible space



**Gas**

Off-campus, for everyone

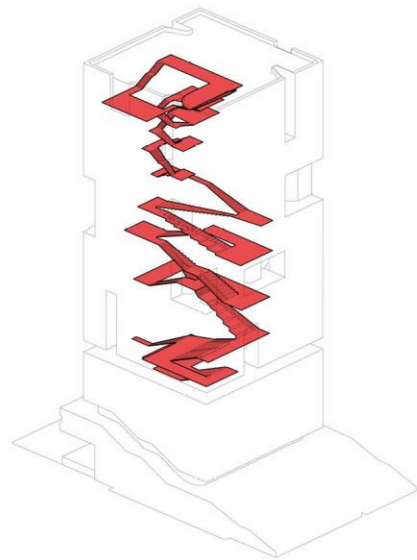

**Academical route**

Connecting different educational spaces

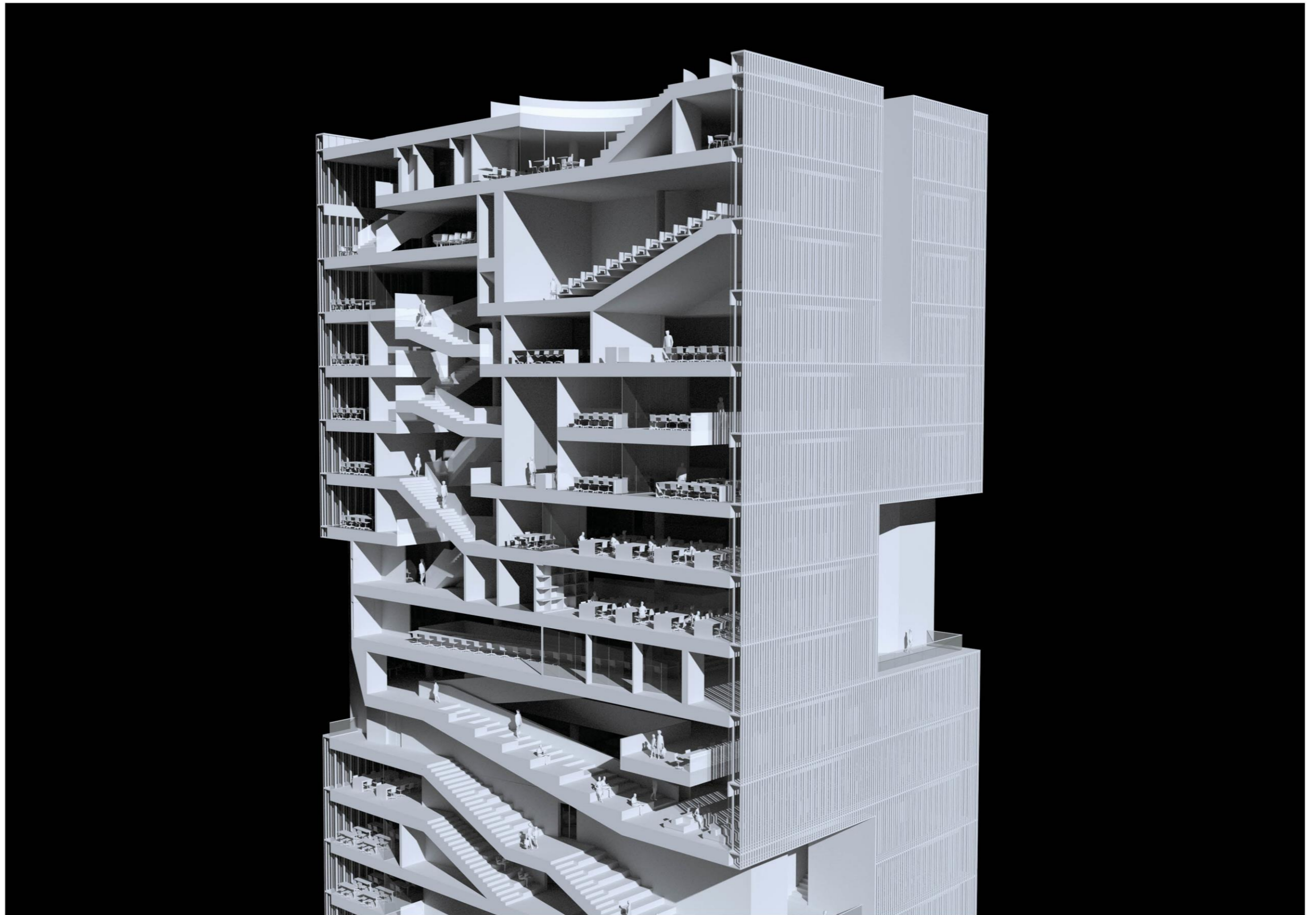



# Floor plans

Connecting studio's

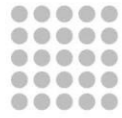

**Solid**

On campus, fixed space

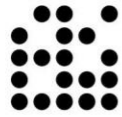

**Liquid**

On campus, flexible space



**Gas**

Off-campus, for everyone

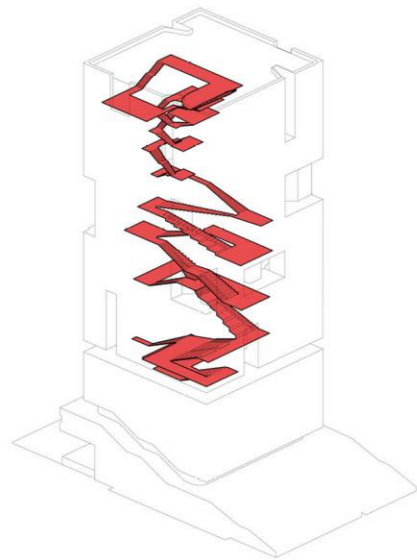

**Academical route**

Connecting different educational spaces



# Floor plans

Twentieth floor

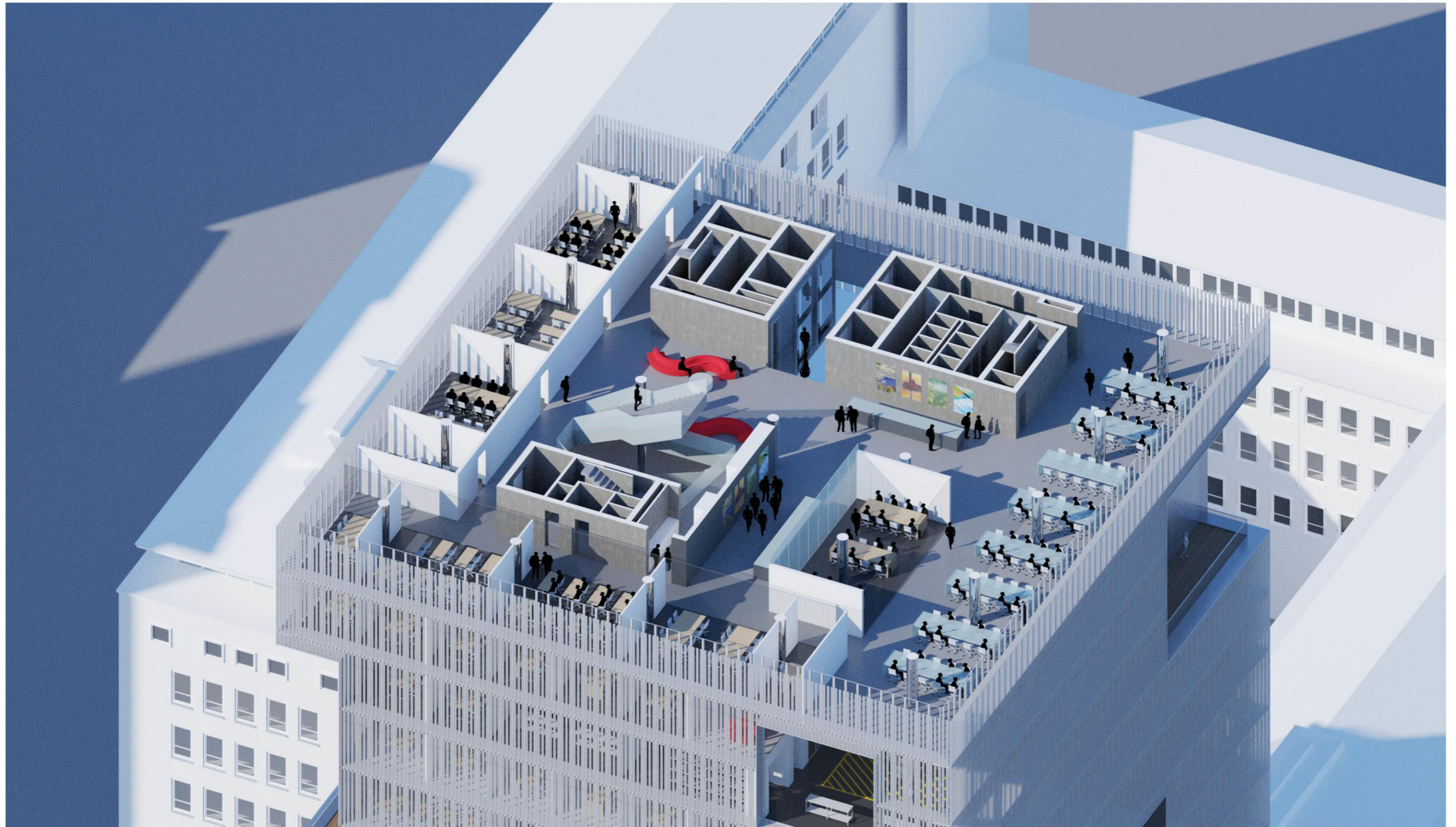

# Floor plans

Twenty-first floor

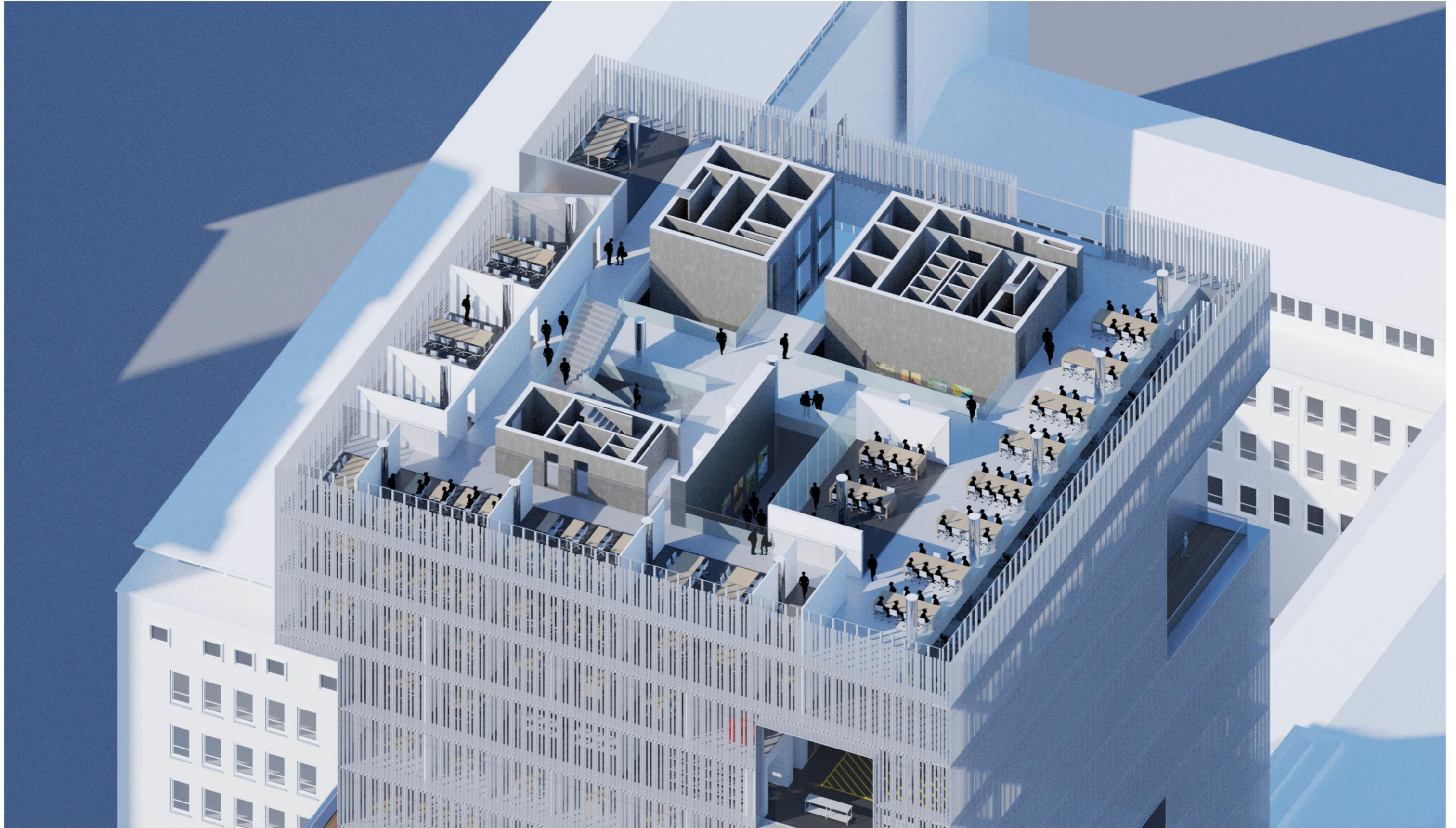

# Floor plans

Connecting studio's

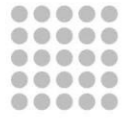

**Solid**  
On campus, fixed space

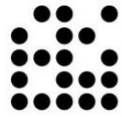

**Liquid**  
On campus, flexible space



**Gas**  
Off-campus, for everyone

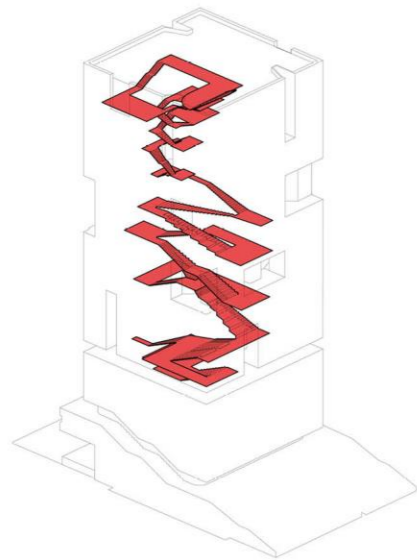

**Academical route**

Connecting different educational spaces

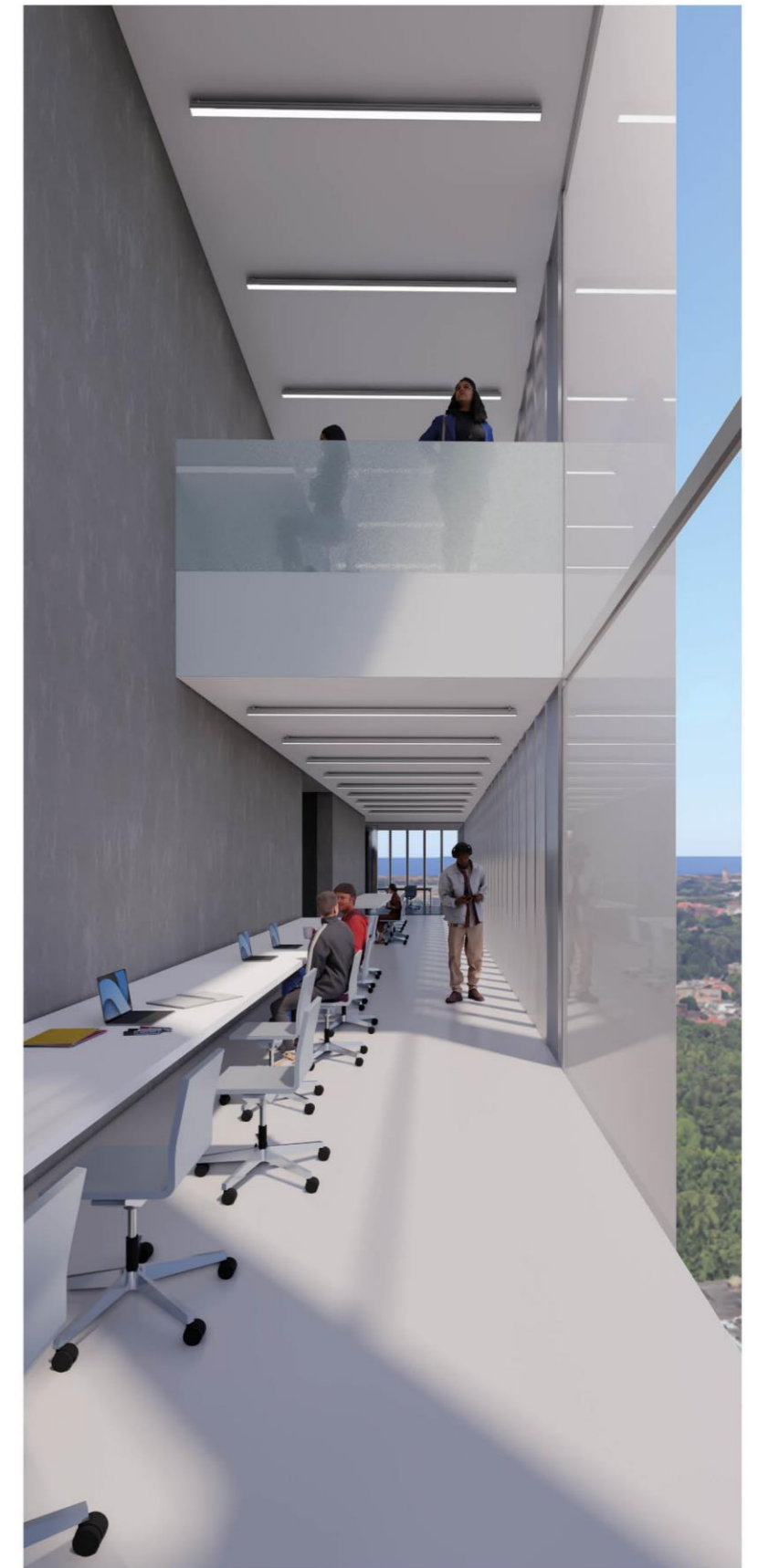

# Floor plans

Studio classroom

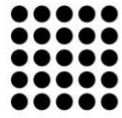

**Solid**

On campus, fixed space



**Liquid**

On campus, flexible space



**Gas**

Off-campus, for everyone

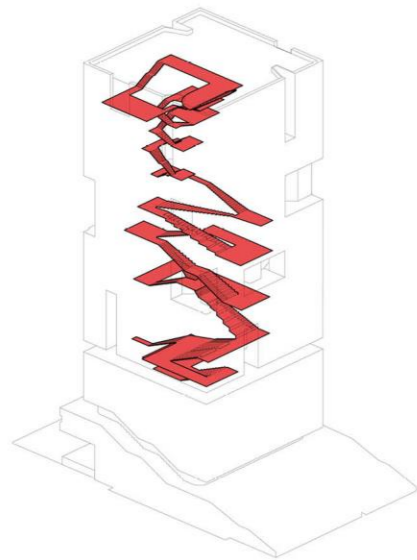

**Academical route**

Connecting different educational spaces



# Floor plans

Studio

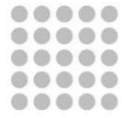

**Solid**

On campus, fixed space

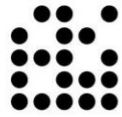

**Liquid**

On campus, flexible space



**Gas**

Off-campus, for everyone

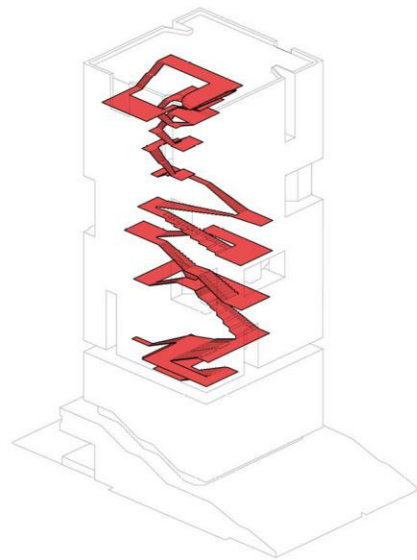

**Academical route**

Connecting different educational spaces



# How do target groups behave?

User scenario

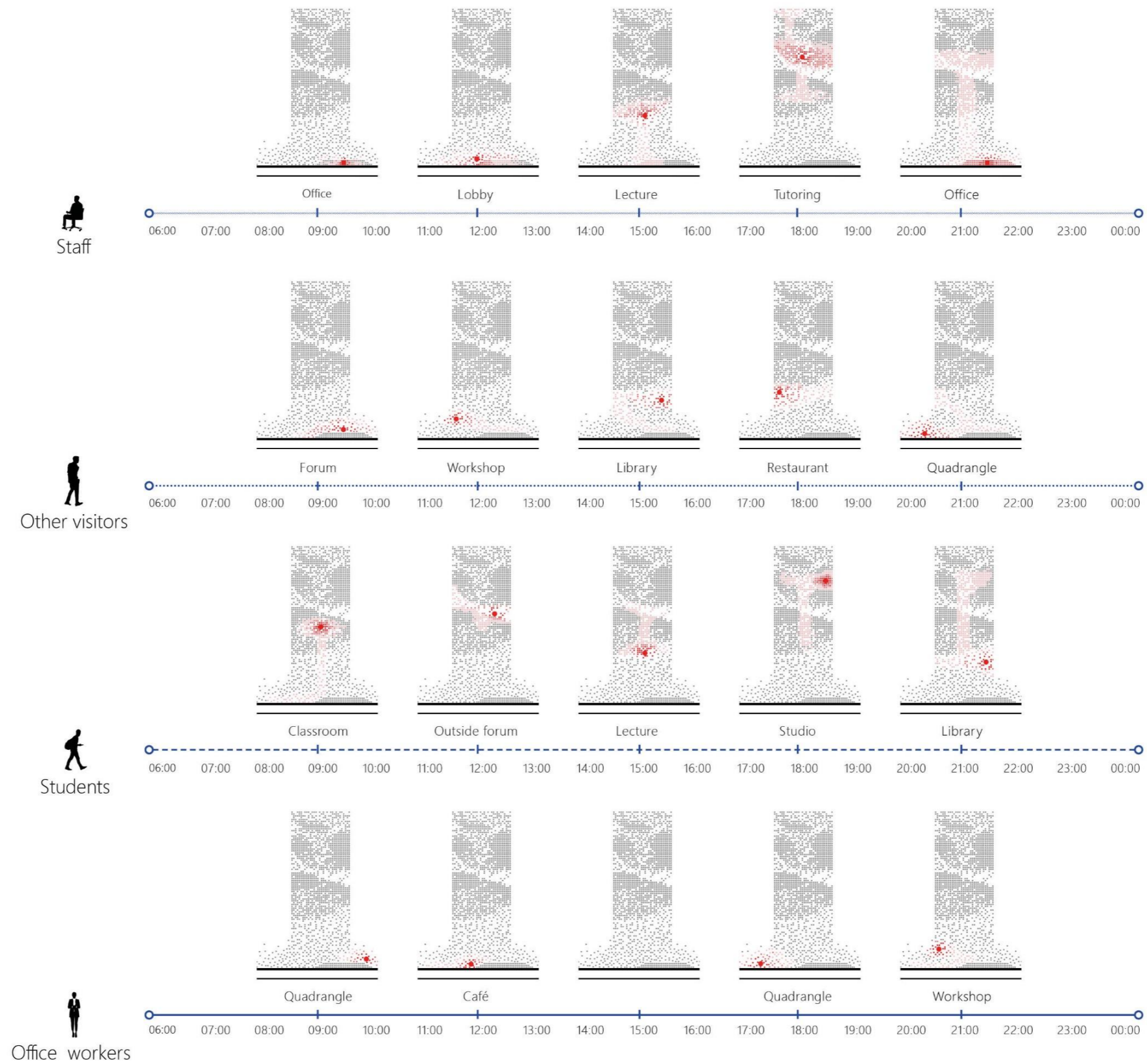

# How do target groups behave?

User scenario



Other visitor user scenario



Forum

**Learn**



Workshop

**Work**



Library

**Research**



Restaurant

**Relax**



Quadrangle

**Interact**



Student user scenario



Classroom

**Learn**

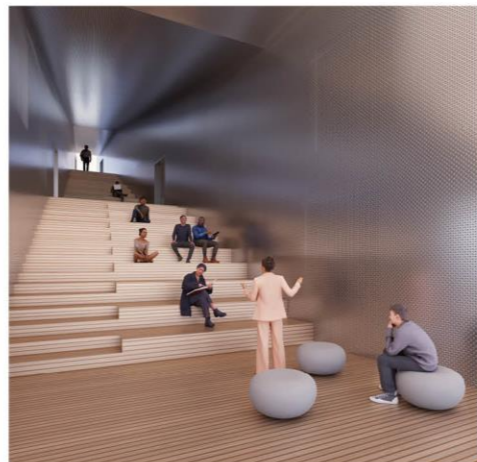

Outside forum

**Debate**



Lecture

**Learn**



Studio

**Work**

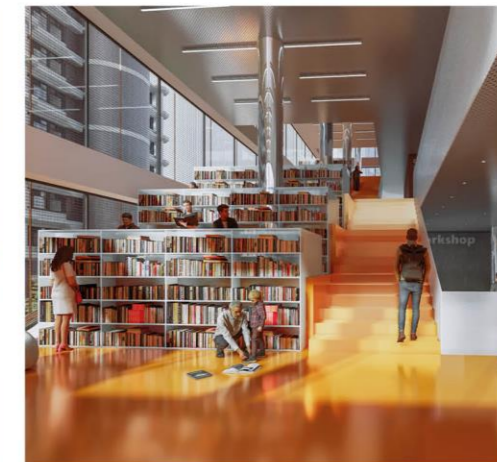

Library

**Research**





# Building technology

A sustainable campus



# Building technology

A sustainable and comfortable campus



## Structure

The structure will provide a 'plan libre' due to the usage of a skeleton of columns and beams



## Materials

Durable, circular and sustainable bio materials, such as wood and recycled concrete, will be used as a construction material.

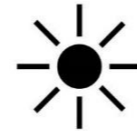

## Natural light

Optimal natural light is necessary to feel and work optimal. This is part of the visual comfort



## Energy

Minimize consuming fossil energy, while maximise green energy. Mostly produced by own sources



## Air quality

Good ventilated spaces due to natural methods, like thermal draft and wind pressure



## Visual comfort

Far sightlines, lots of natural daylight and proper usage of colors have a positive impact on peoples well being



## Thermic comfort

The physical environment will be as adaptive as possible to ensure thermal comfort for well-being



## Acoustic comfort

Reducing noise pollution from outside and improve the performance of desired and self-created sound



## Water usage

Reduce water usage and ensuring a balance in the distribution and management of water resources



## Greenery

Adding greenery to both interiors and exteriors stimulates thermal, acoustic, and visual comfort, as well as air quality

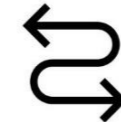

## Movement

Stimulate physical movement through stairs, slopes and other adaptive routing



## Community

Adding features to stimulate a healthy and open community feeling (identity) for the target groups

# Building technology

A sustainable and comfortable campus

- 01 Green roof for thermal cooling and smart water usage
- 02 High ceilings for natural light
- 03 Single sided natural ventilation (for smaller rooms)
- 04 Open spaces to provide visual comfort
- 05 Manual windows for user controle
- 06 Ground source cooling and heating via aquifer storage
- 07 Heath pump
- 08 Photovoltaic panels for solar shading and electricity
- 09 Excess electricity from photovoltaic panels stored in battery
- 10 Acces walkway for sun shading
- 11 Ventilation type D with heat recovery system
- 12 Natural air extraction from high ceilings (atrial effect)
- 13 Green quadrangle for acoustic, visual comfort and air quality.

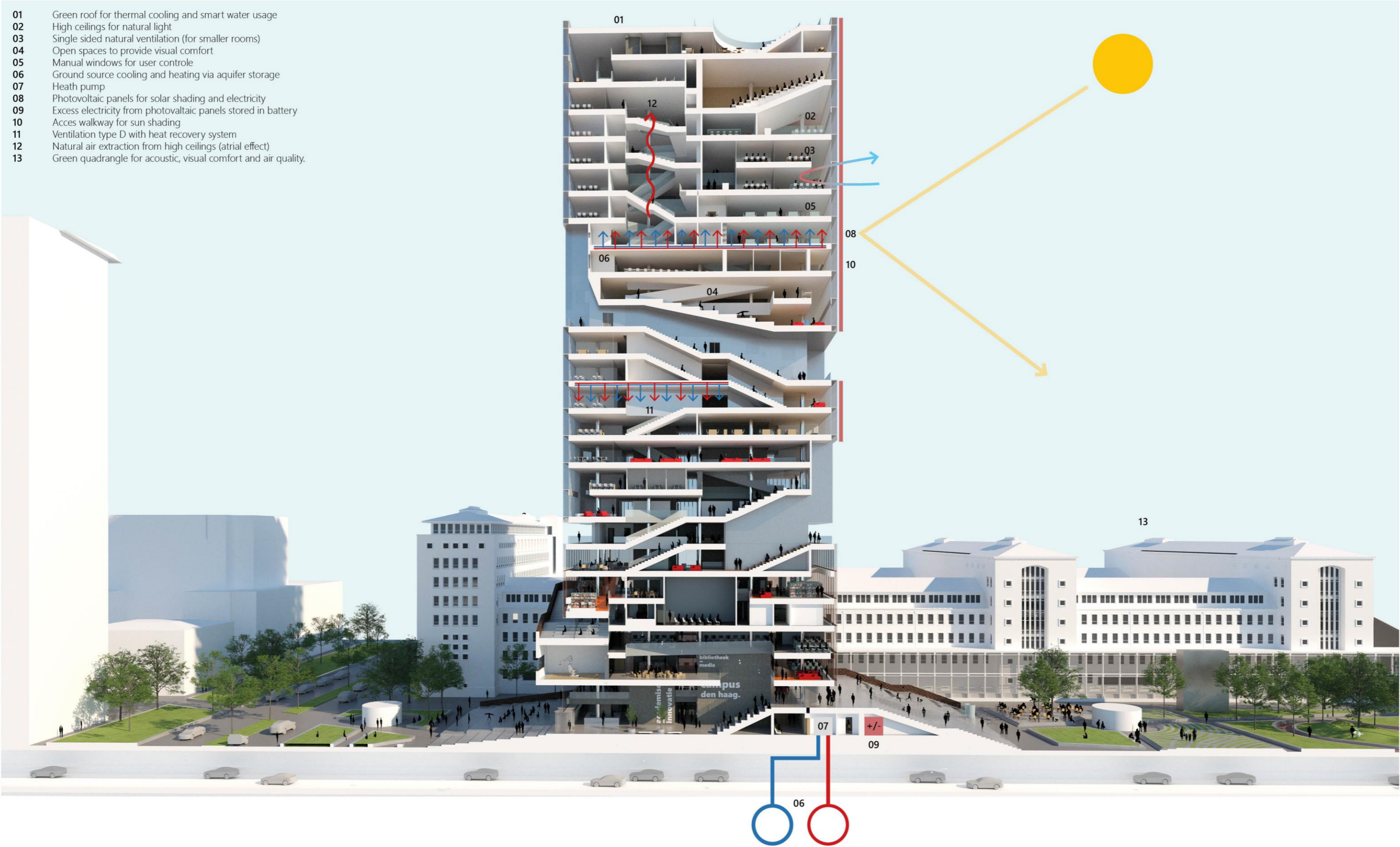

# Building technology

Shearing layers

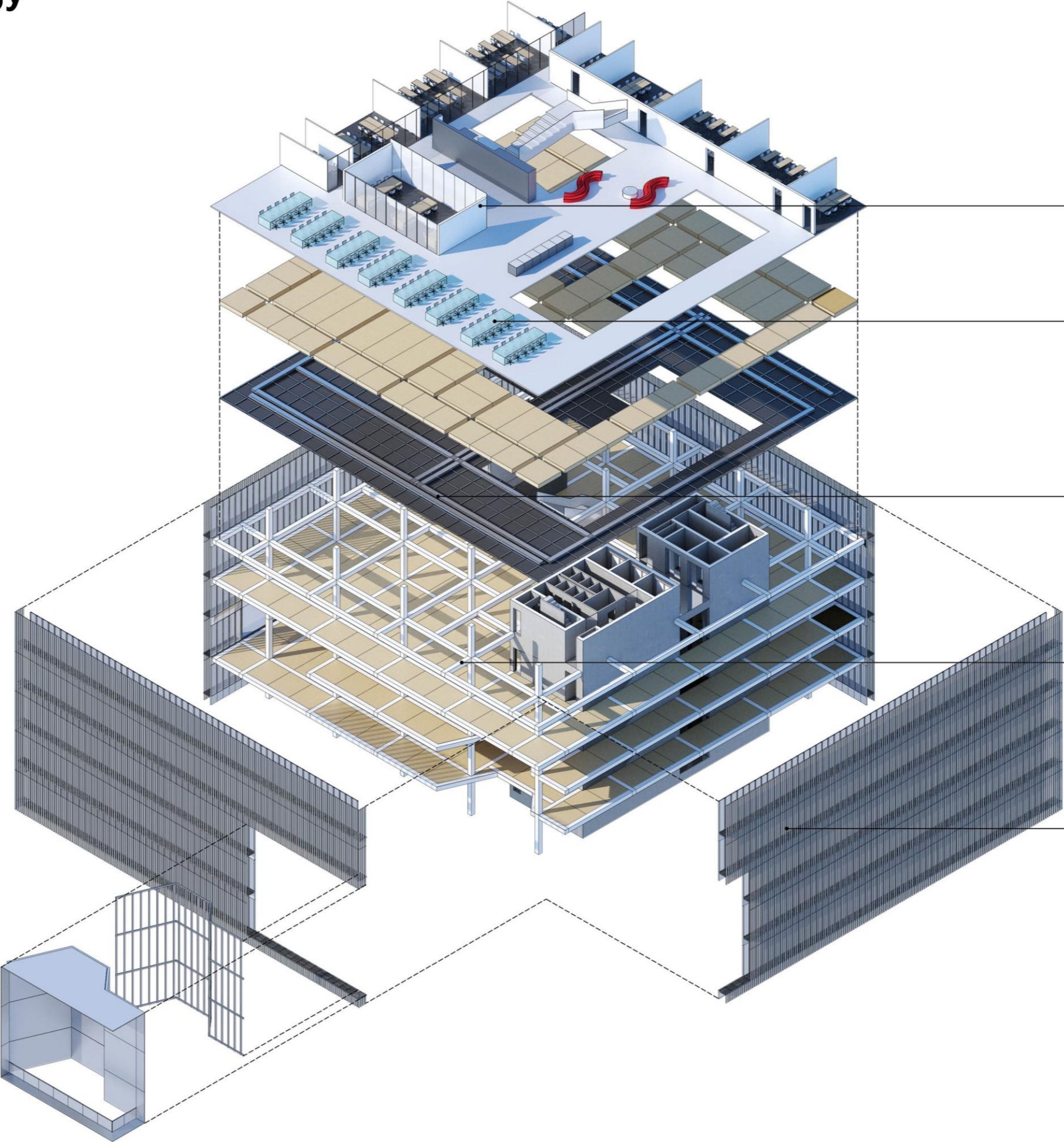
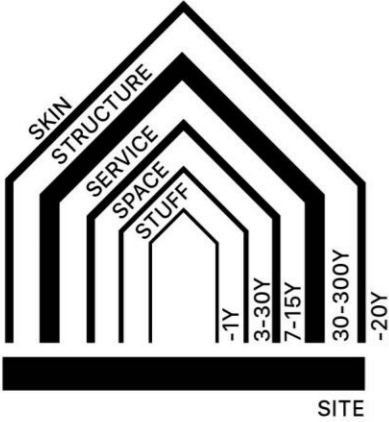

**Space**  
 Circulation system (generic)  
 Multifunctional stairs (specific)  
 Walls (generic)  
 Adaptable and flexible walls (specific)

**Stuff**  
 Movable furniture  
 Personal belongings  
 Appliances

**Services**  
 Lowered ceiling (generic)  
 Open space for services (specific)  
 Ventilation shafts  
 Electrical wiring  
 Plumblings  
 Communication networks

**Structure**  
 Load bearing components (generic)  
 Adaptable and flexible walls (specific)  
 Concrete core (generic)

**Skin**  
 Facade curtain wall (generic)  
 PV panels and openings (specific)

# Hybrid construction

CLT-Concrete-Steel

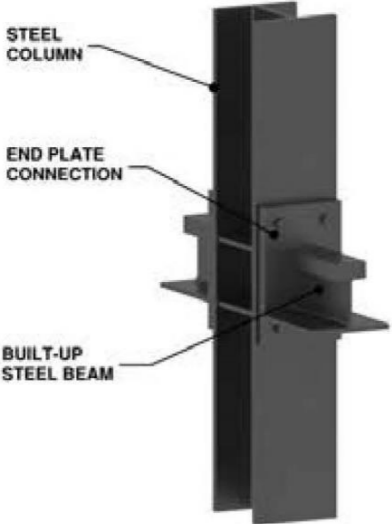

Stage 1 - Steel framing

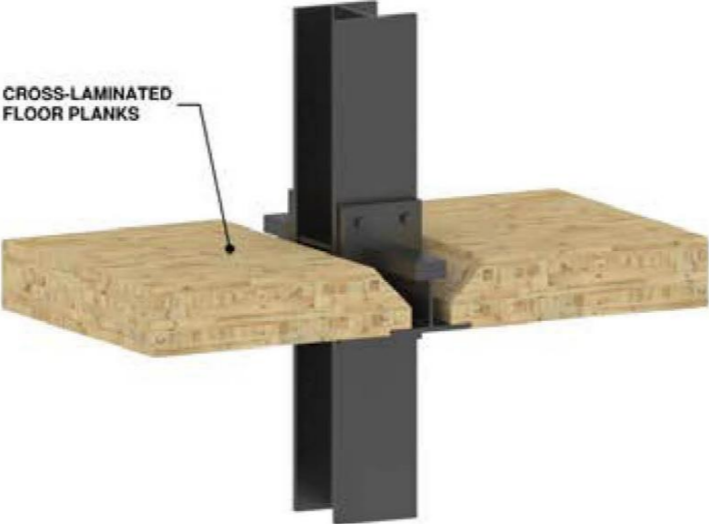

Stage 2- CLT floor planks

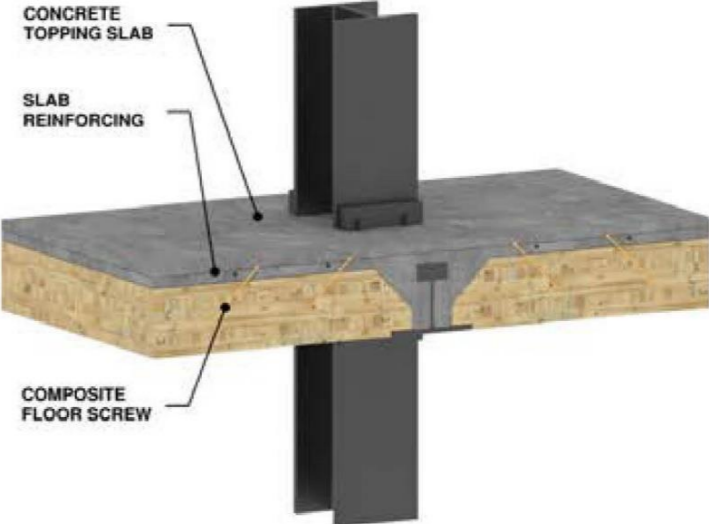

Stage 3 - Concrete topping

# Hybrid construction

CLT-Concrete-Steel

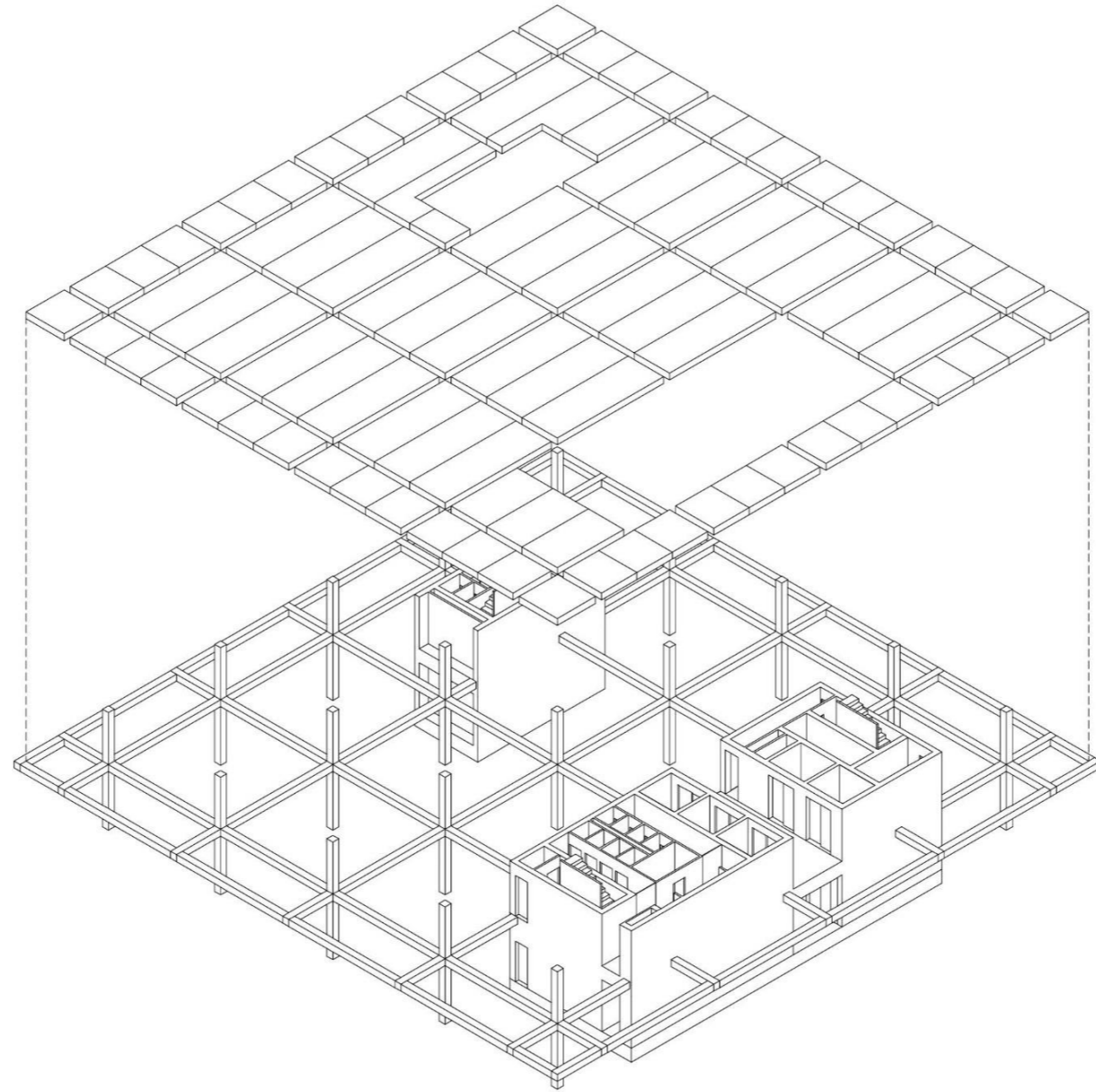

## Hybrid construction

Combining Cross Laminated Timber, recycled concrete and Steel in the chosen grid

# Hybrid construction

CLT-Concrete-Steel

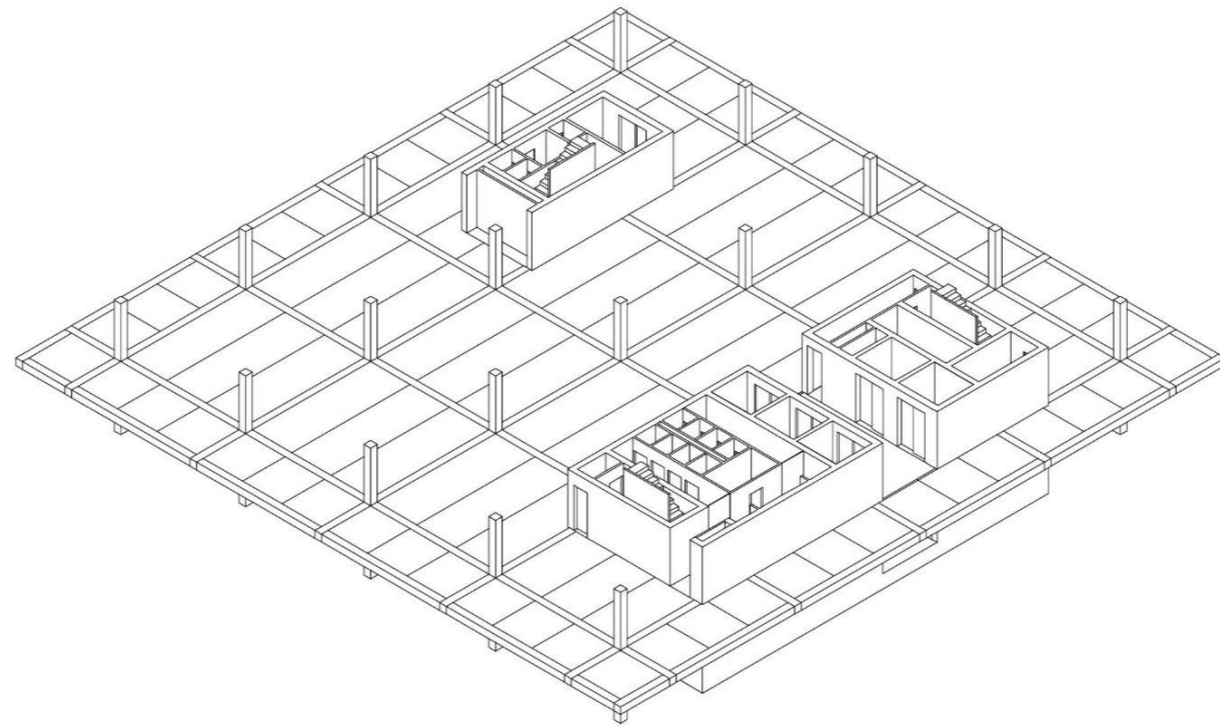

## Basic principle

CLT floors and steel columns, horizontally stabilized by concrete cores, in a basic floorplan

# Hybrid construction

CLT-Concrete-Steel

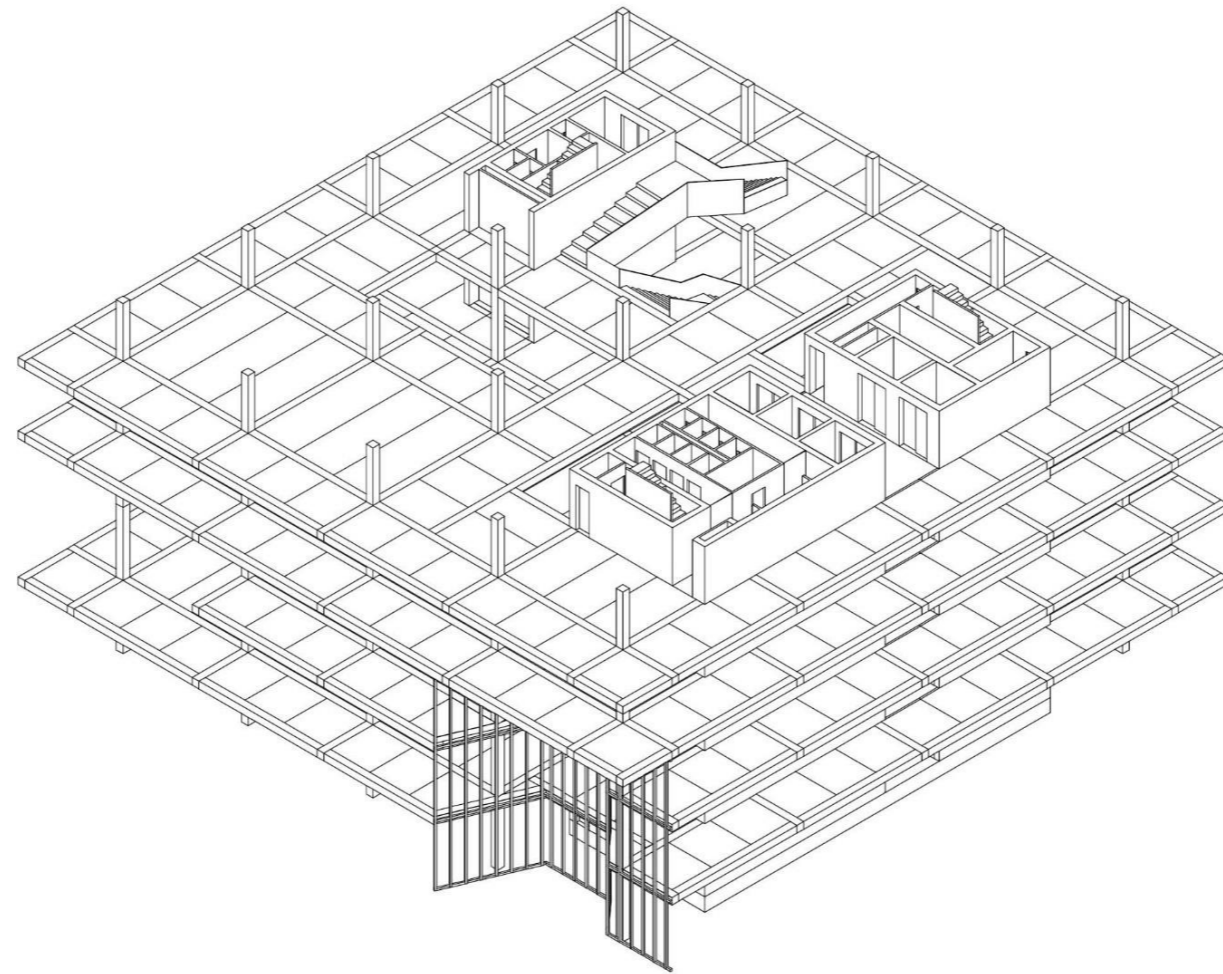

## Stacking layers

Showing different possibilities within the plan  
libre with the hybrid construction



# Hybrid construction

CLT-Concrete-Steel

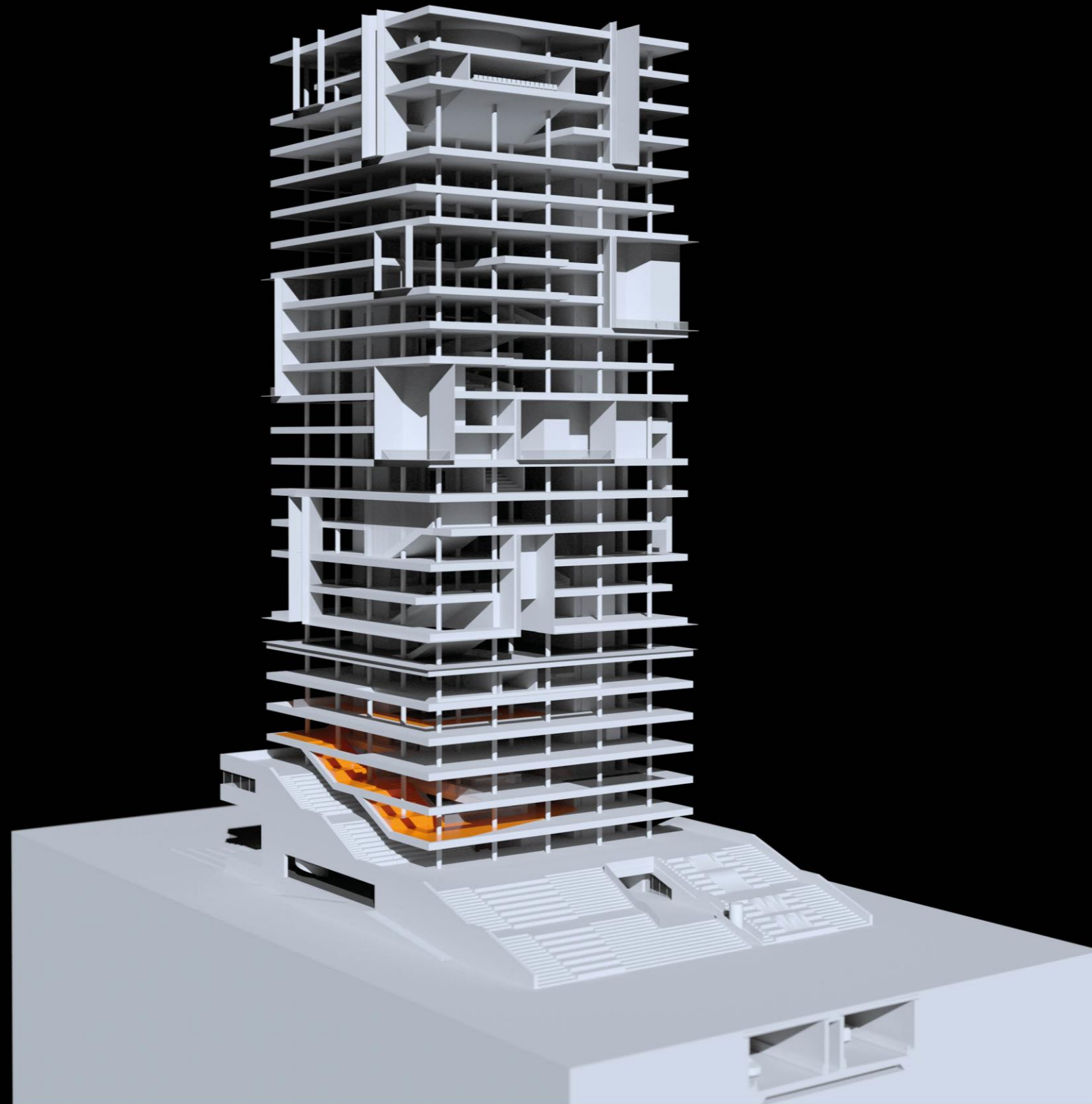

# Facade fragment

CLT-Concrete-Steel

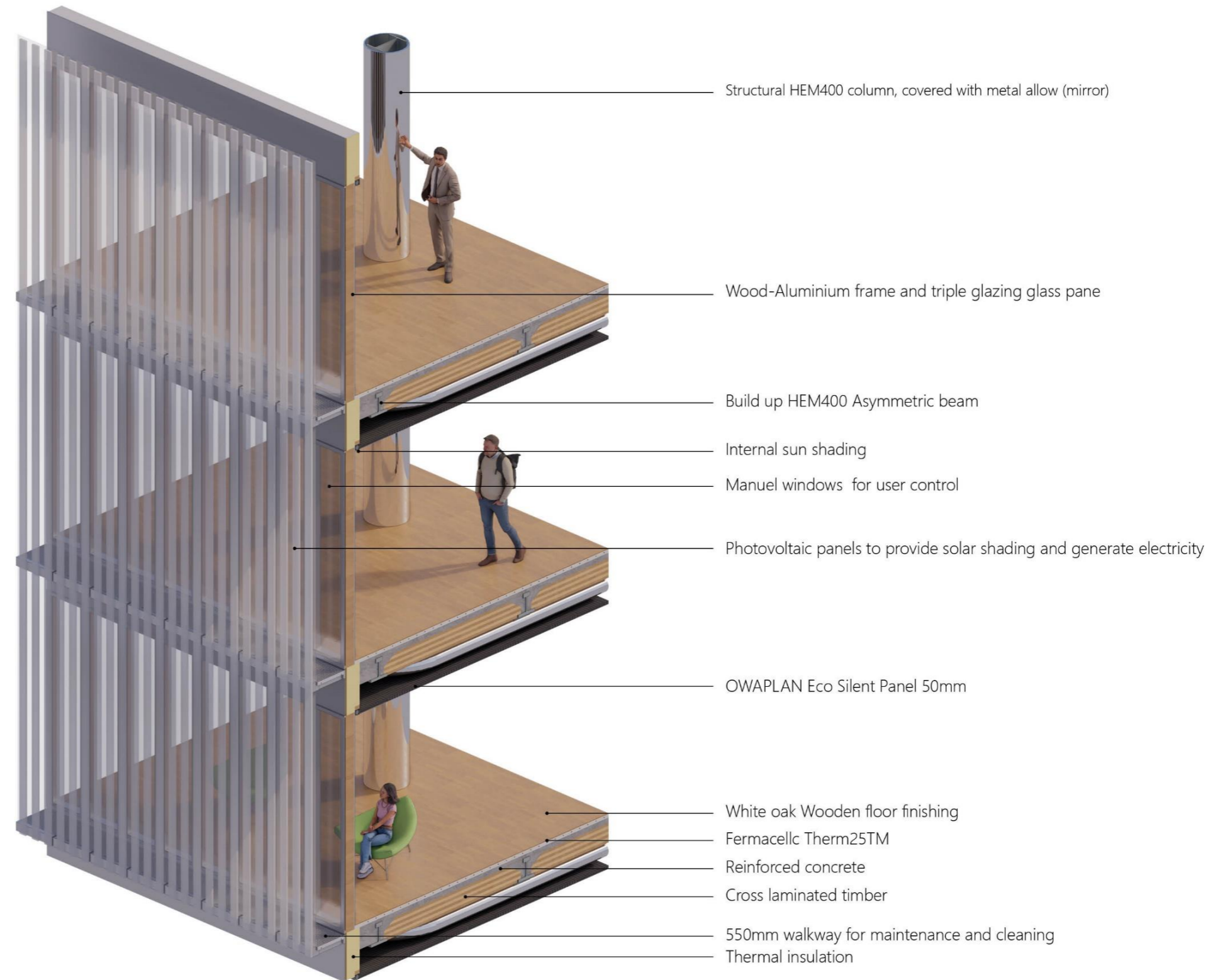

# Facade fragment

In detail

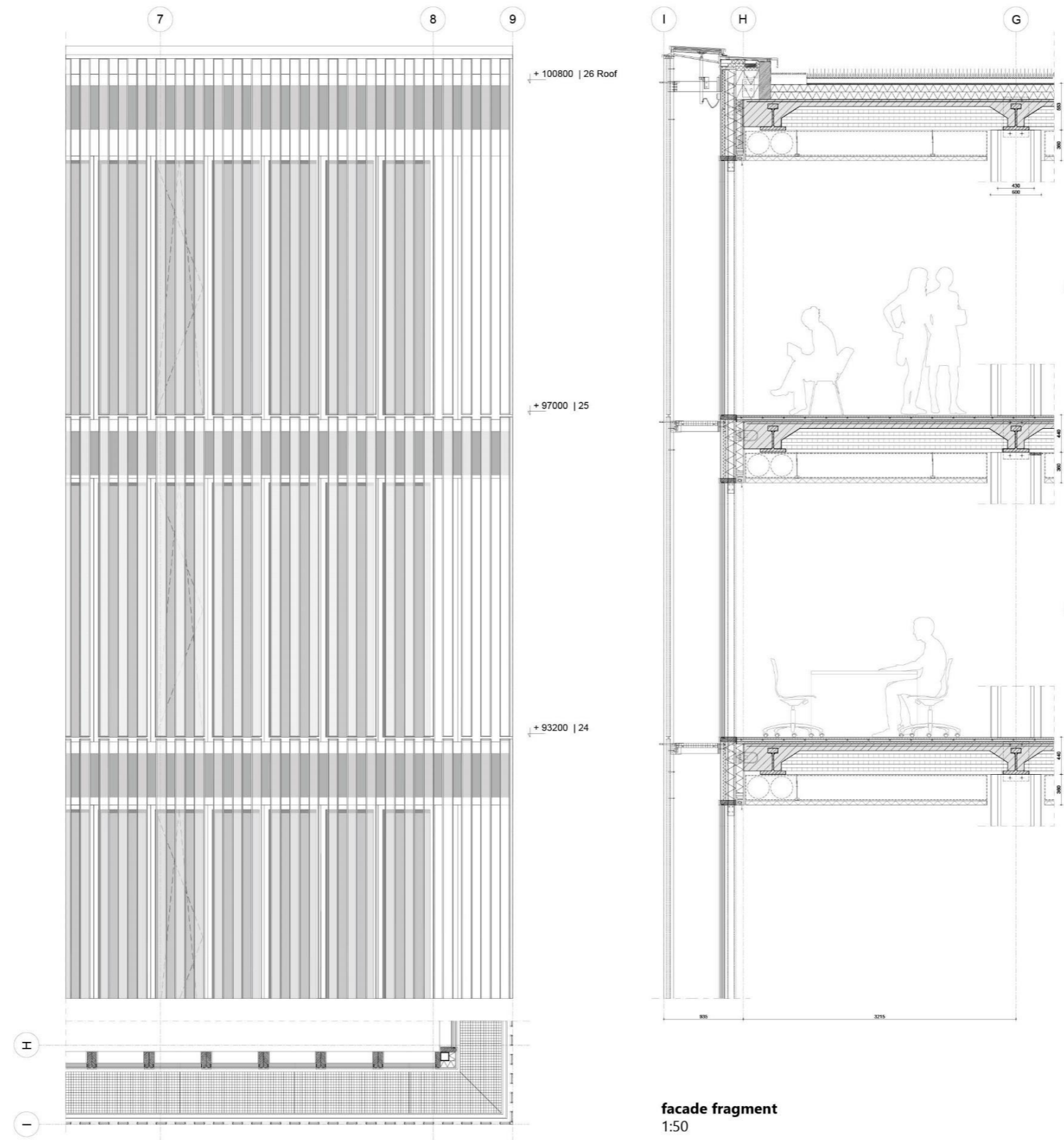

facade fragment  
1:50

# Detailing

Vertical

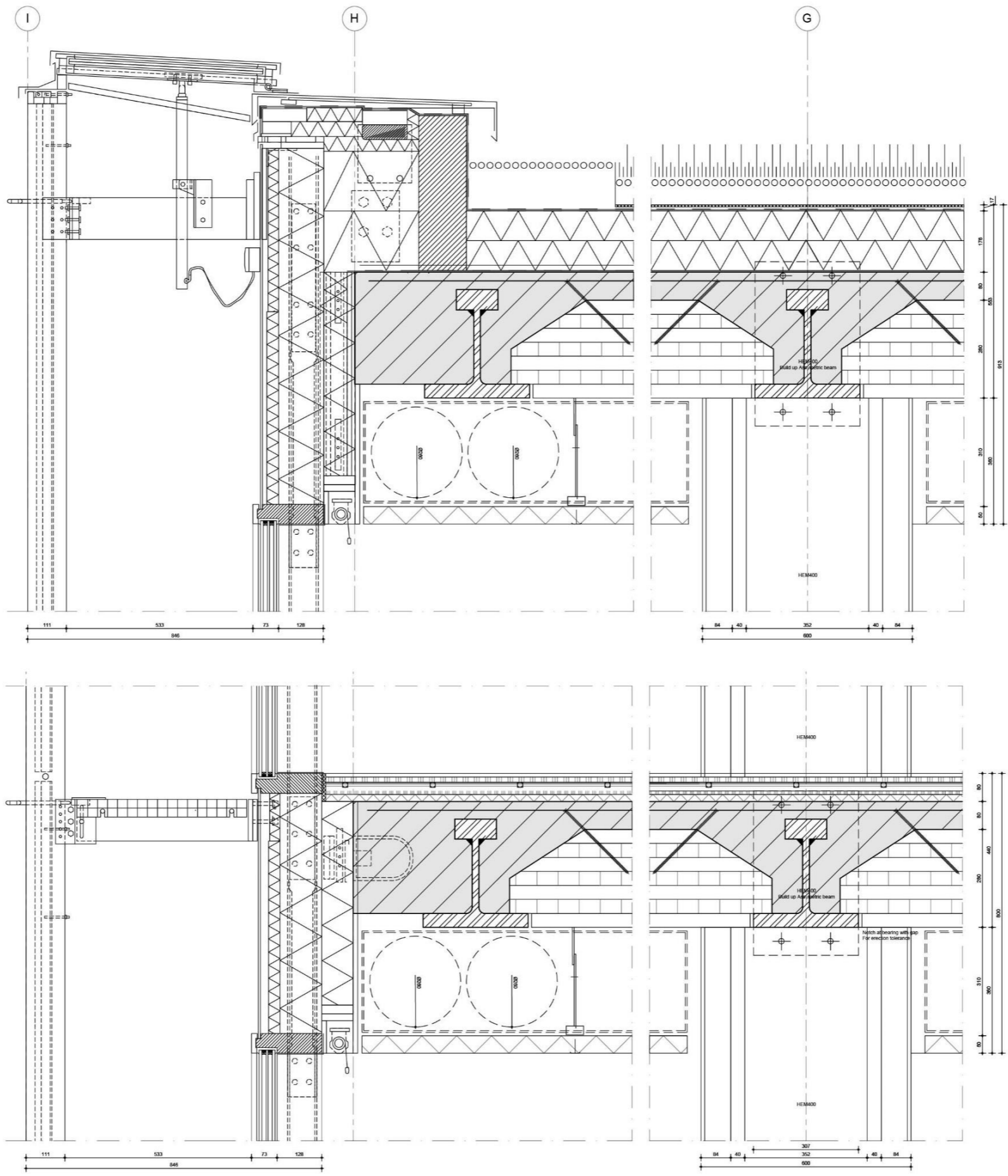

# Detailing

Horizontal

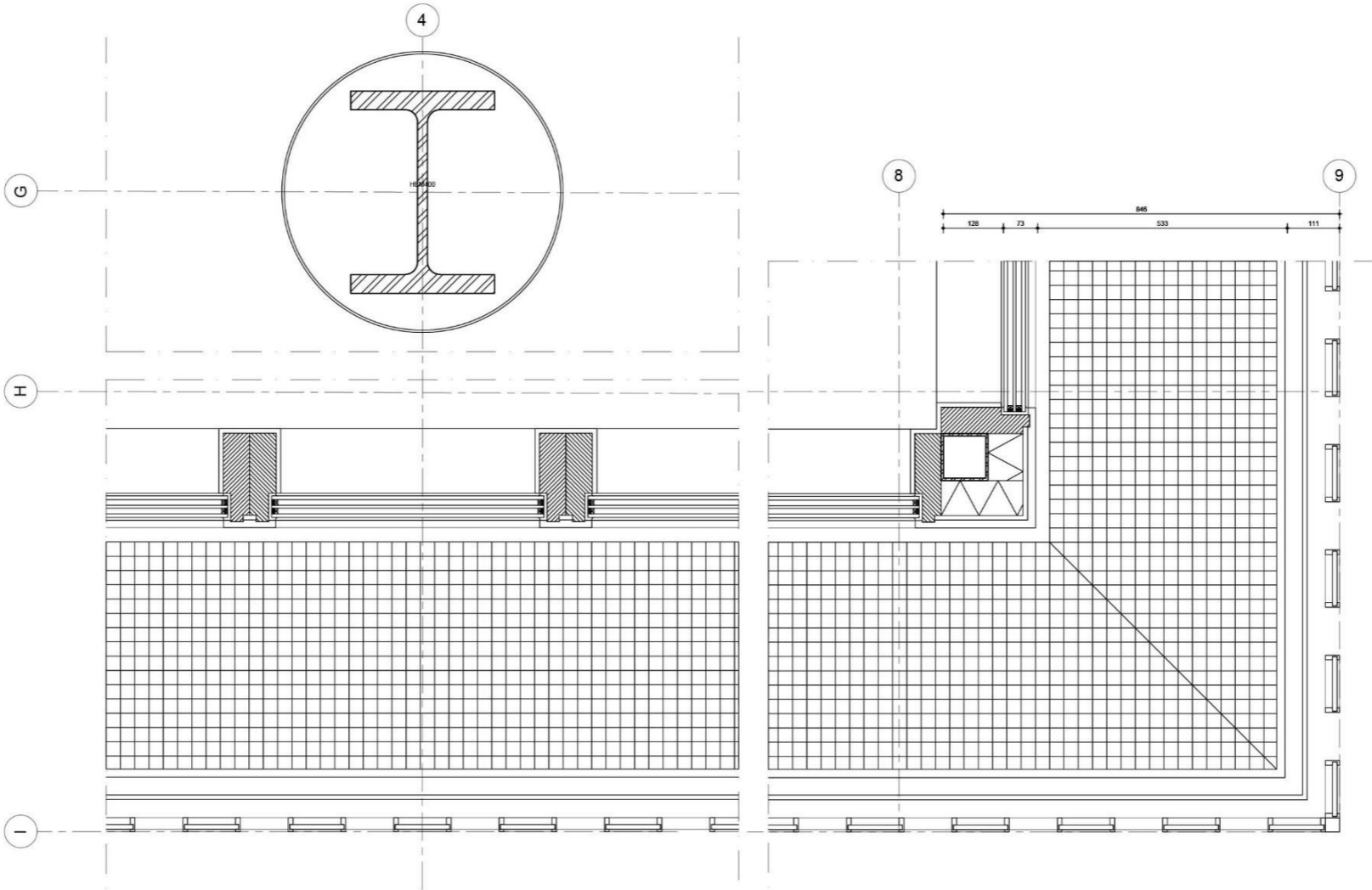

# Facade fragment

Carbon negative design

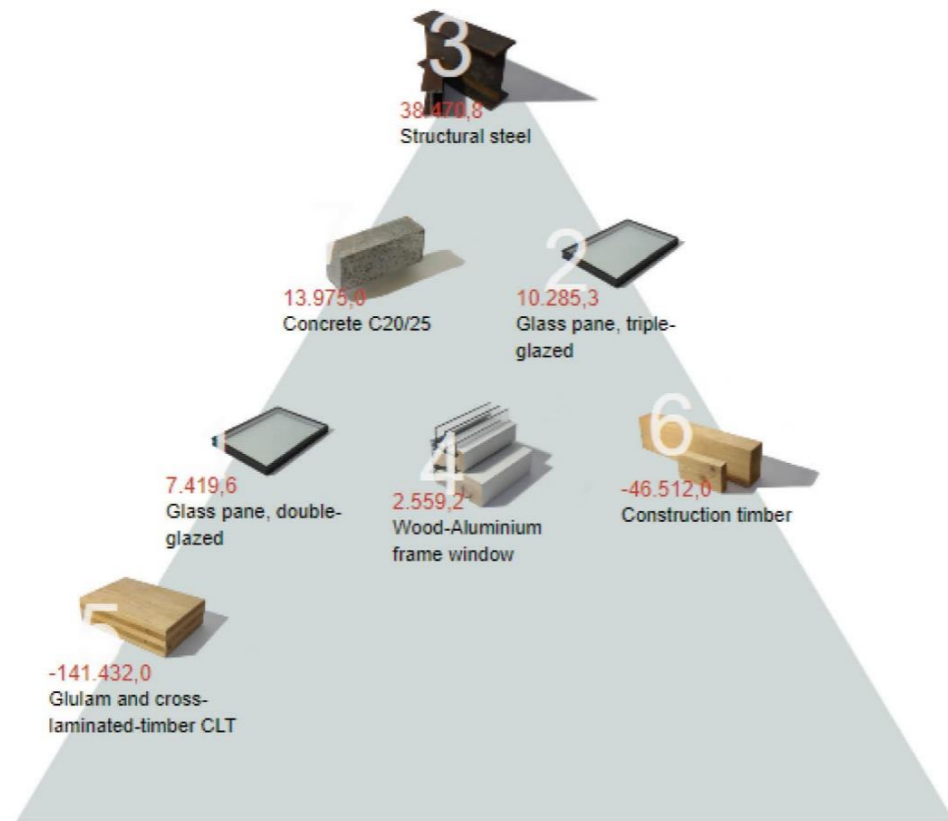

| kg CO<sup>2</sup> eq  
| module A1-A3

Your pyramid:  
-115.234,2 kg CO<sup>2</sup> eq

1467 m<sup>2</sup> / -115.234,2 kg CO<sub>2</sub> eq

= -78,6 kg CO<sub>2</sub> eq/m<sup>2</sup>

-78,6 kg CO<sub>2</sub> eq/m<sup>2</sup> \* ca. 30.000 m<sup>2</sup>

**= -2.356.711 kg CO<sub>2</sub> eq TOTAL GWP IMPACT**

	material	group	impact / m3	volume [m3]	area [m2]	thickness [mm]	result
1	Glass pane, double-glazed	komponenter	4580.0 kg CO2eq/m3	1,62 m3		mm	7.419,6 kg CO <sub>2</sub> eq
2	Glass pane, triple-glazed	komponenter	4761.7 kg CO2eq/m3	2,16 m3		mm	10.285,3 kg CO <sub>2</sub> eq
3	Structural steel	metal	5403.2 kg CO2eq/m3	7,12 m3		mm	38.470,8 kg CO <sub>2</sub> eq
4	Wood-Aluminium frame window	komponenter	592.4 kg CO2eq/m3	4,32 m3		mm	2.559,2 kg CO <sub>2</sub> eq
5	Glulam and cross-laminated-timber CLT	trae	-664.0 kg CO2eq/m3	213 m3		mm	-141.432,0 kg CO <sub>2</sub> eq
6	Construction timber	trae	-680.0 kg CO2eq/m3	68,4 m3		mm	-46.512,0 kg CO <sub>2</sub> eq
7	Concrete C20/25	mineralsk	215.0 kg CO2eq/m3	65 m3		mm	13.975,0 kg CO <sub>2</sub> eq
							<b>-115.234,2 kg CO<sub>2</sub> eq</b>

# academic and innovation campus the hague

*navigating university identity*



## Public Building

*To connect and enrich neighbourhoods*

## Vertical campus

*To educate and innovate the CID*

## University identity

*Gas public base and solid-liquid academical top*

## Sustainable

*Comfortable, self sufficient and carbon negative*