

**The Prospect of Microwave Heating
Towards a Faster and Deeper Crack Healing in Asphalt Pavement**

Xu, Shi; Liu, Xueyan; Tabakovic, Amir; Schlangen, Erik

DOI

[10.3390/pr9030507](https://doi.org/10.3390/pr9030507)

Publication date

2021

Document Version

Final published version

Published in

Processes

Citation (APA)

Xu, S., Liu, X., Tabakovic, A., & Schlangen, E. (2021). The Prospect of Microwave Heating: Towards a Faster and Deeper Crack Healing in Asphalt Pavement. *Processes*, 9(3), 1-11. Article 507. <https://doi.org/10.3390/pr9030507>

Important note

To cite this publication, please use the final published version (if applicable). Please check the document version above.

Copyright

Other than for strictly personal use, it is not permitted to download, forward or distribute the text or part of it, without the consent of the author(s) and/or copyright holder(s), unless the work is under an open content license such as Creative Commons.

Takedown policy

Please contact us and provide details if you believe this document breaches copyrights. We will remove access to the work immediately and investigate your claim.

Article

The Prospect of Microwave Heating: Towards a Faster and Deeper Crack Healing in Asphalt Pavement

Shi Xu ¹, Xueyan Liu ¹, Amir Tabaković ^{1,2,3} and Erik Schlangen ^{1,*}

¹ Civil Engineering and Geosciences, Delft University of Technology, 2628CN Delft, The Netherlands; s.xu-1@tudelft.nl (S.X.); x.liu@tudelft.nl (X.L.); amir.tabakovic@TUDublin.ie (A.T.)

² Centre for Research in Engineering Surface Technology (CREST), Technological University Dublin, D08CKP1 Dublin, Ireland

³ School of Civil Engineering, University College Dublin, D04K3H4 Dublin, Ireland

* Correspondence: Erik.Schlangen@tudelft.nl

Abstract: Microwave heating has been shown to be an effective method of heating asphalt concrete and in turn healing the damage. As such, microwave heating holds great potential in rapid (1–3 min) and effective damage healing, resulting in improvement in the service life, safety, and sustainability of asphalt pavement. This study focused on the microwave healing effect on porous asphalt concrete. Steel wool fibres were incorporated into porous asphalt to improve the microwave heating efficiency, and the optimum microwave heating time was determined. Afterwards, the microwave healing efficiency was evaluated using a semi-circular bending and healing programme. The results show that the microwave healing effect is largely determined by the steel fibre content and the mix design of the porous asphalt concrete. Besides, the uneven heating effect of microwave contributes to an unstable damage recovery in the asphalt mixture, which makes it less efficient than induction heating. However, microwaves exhibited the ability to penetrate further into the depth of the test specimen and heat beneath the surface, indicating deeper damage recovery prospects.

Keywords: self-healing asphalt; microwave heating; porous asphalt; semi-circular bending



Citation: Xu, S.; Liu, X.; Tabaković, A.; Schlangen, E. The Prospect of Microwave Heating: Towards a Faster and Deeper Crack Healing in Asphalt Pavement. *Processes* **2021**, *9*, 507. <https://doi.org/10.3390/pr9030507>

Academic Editors: Antonino Recca and Andrea Petrella

Received: 27 January 2021

Accepted: 5 March 2021

Published: 11 March 2021

Publisher's Note: MDPI stays neutral with regard to jurisdictional claims in published maps and institutional affiliations.



Copyright: © 2021 by the authors. Licensee MDPI, Basel, Switzerland. This article is an open access article distributed under the terms and conditions of the Creative Commons Attribution (CC BY) license (<https://creativecommons.org/licenses/by/4.0/>).

1. Introduction

Asphalt pavement, throughout its service life, has the ability to repair its own damage and recover its strength and fatigue life autonomously during rest periods [1–5]. Research has demonstrated that temperature is the dominant factor influencing the self-healing properties of asphalt concrete, which means that an increase in the test temperature not only increases the self-healing rate but also shortens the total time needed for full healing [6,7]. Based on this concept, methods including induction heating and microwave heating are developed to achieve self-healing in asphalt concrete by increasing the temperature [8,9].

As a promising extrinsic asphalt healing method, induction heating heats up asphalt mixture containing conductive particles with a high-frequency alternating electromagnetic field generated by an induction coil [10–13]. However, the gradient temperature distribution, the induction heating speed, and the availability of a large-scale induction vehicle limit the widespread application of this technique in the field [14].

Similar to induction heating, microwave heating is also considered an effective extrinsic technique to promote the self-healing of bituminous materials. Due to their advantages in heating, such as their fast speed, good uniformity, and energy-saving potential, microwaves are widely used in our daily life, as well as in the food industry, medicine production, and other fields [15]. During the heating process, microwave radiation applies alternating electromagnetic fields with a higher frequency than induction, in the order of megahertz, causing a change in the orientation of polar molecules, which results in internal friction and increases the material temperature [16]. In this way, the bitumen begins to flow, and the damages get healed.

Norambuena-Contreras et al. [8] found that microwave heating increased the temperature of the binder, not the aggregates, and as such normal asphalt mixture can be heated with microwave heating energy. González et al. [16] also indicated that asphalt mixtures with aggregates that were naturally heated with microwave radiation could be crack-healed.

However, with some additives, the microwave heating speed can be accelerated significantly. The ferrous particles are the most common materials used to enhance the microwave heating effect in asphalt mixture, because they can absorb and conduct more thermal energy than other mixture components. Zhao et al. [17] indicated that addition of ferrite particles can largely increase the microwave heating speed in asphalt concrete.

Steel wool fibres are usually used to enhance the microwave healing effect in asphalt mixture. In a microwave crack healing study, Gallego et al. [18] incorporated steel wool fibres into an asphalt mixture, and found these steel wool fibres made it more susceptible to the energy of the microwaves. Gallego et al. indicated that the microwave heating requires much less steel fibre content and energy consumption, but shows higher heating efficiency in contrast to the induction heating. Similar results were reported by Norambuena-Contreras et al. [19]. In another study, Norambuena-Contreras et al. [8] compared the healing effects from induction heating and microwave heating, which confirmed the higher healing efficiency of the microwave heating, but indicated that microwave heating could result in a change in the air voids' structure.

In a microwave technique application study, Gao et al. [20] found that steel slag possesses a higher microwave heating capacity in contrast to limestone aggregate, which is due to the higher hyperactive (Fe_3O_4) and active (Fe_2O_3 and FeS) content in steel slag. Phan et al. [21] used coarse steel slag to replace normal aggregate, which also showed an improved microwave healing effect in asphalt mixture. Wang et al. [22] reported similar findings and used a numerical model to simulate the microwave heating of asphalt mixture, which showed a good correlation with laboratory test results.

The use of fine ferrous particles in microwave healing was also investigated. Li et al. [23] tested the microwave healing effect of asphalt mixture with steel slag fillers and found that, under microwave irradiation, steel slag fillers based asphalt mastics could release more heat than limestone fillers based asphalt mastics. Li et al. explained this with the higher relative complex permittivity, relative complex permeability, and reflection loss of steel slag filler than of limestone filler. In another study, Zhao et al. [17] tested the microwave heating with three types of filler additives in asphalt mixture and indicated that NiZn ferrite powders have an excellent microwave absorbing capacity, and an increase in the NiZn ferrite content resulted in a significant increase of the heating speed of asphalt mastic, asphalt matrix, and asphalt concrete.

Except for ferrite particles, carbon-based materials have also been investigated in asphalt mixture for microwave healing. Wang et al. [24] reported that carbon fibre, as a modifier, could increase the thermal conductivity and fracture strength due to fibre reinforcement. Wang et al. also indicated that the addition of carbon fibres could achieve superior microwave healing performance in the fracture-healing cycles. Karimi et al. [25] proposed activated carbon as a potentially viable and robust binder-based conductive component for the microwave-induced heating and healing of asphalt concrete.

The literature review indicates that microwave healing is a promising damage healing method for asphalt mixture, with an excellent heating speed, fewer additive requirements, and less energy consumption compared to induction heating. As such, this study looked into the microwave healing prospect of porous asphalt concrete (PAC). Firstly, PAC samples with three different mixture designs were prepared, and then a proper microwave heating time was determined. Afterwards, a semi-circular bending (SCB) and healing programme was carried out to investigate the microwave healing efficiency on these PAC samples. Finally, the test results were compared with the healing efficiency of other asphalt self-healing systems in the authors' previous work [26,27].

2. Materials and Methods

2.1. Materials

In this study, the microwave heating effect was investigated in porous asphalt, which is prone to ravelling. Steel Wool Fibres (SWF) were incorporated into the asphalt mix to improve its electromagnetic response, and, therefore, a higher microwave heating efficiency. The SWF had a density of 7.6 g/cm^3 , an average length of 1.4 mm, a diameter of $40 \text{ }\mu\text{m}$, and a resistivity of $7 \times 10^{-7} \text{ }\Omega\cdot\text{cm}$. Table 1 shows the three mix compositions of the PAC used in this study, which were designed and verified based on porous asphalt structures in field applications by Heijmans in the Netherlands. The mix constituent indicates the diameter of the sieve mesh to distinguish the aggregate sizes. PA1 and PA2 were designed following the standard PA 0/8, while PA3 was designed following the standard PA 0/11, and the void content was 20% for the asphalt mixtures in this study. Two different SWF contents were used in the asphalt mixtures, in which 3% SWF (by volume of bitumen) was applied in PA1, while 6% SWF was applied in PA2 and PA3.

Table 1. The mix compositions of the asphalt mixture.

Mix Constituent	% Content in Mix		
	PA1	PA2	PA3
16 mm	-	-	7.97
11.2 mm	8.21	8.12	62.00
8 mm	42.68	42.18	7.97
5.6 mm	29.13	28.79	1.78
2 mm	7.85	7.74	9.86
63 μm	5.61	5.55	4.22
Bitumen	5.34	5.27	4.32
Steel Fibres	1.18	2.33	1.88

The asphalt mixtures were mixed with a laboratory drum mixer and then compacted into slabs with a roller compactor. Afterwards, the semi-circular asphalt samples with the dimensions shown in Figure 1 were prepared by drilling and cutting from these slabs for the SCB tests. The detailed asphalt slab production and cutting of the SCB samples can be referred to the authors' previous publication [28].

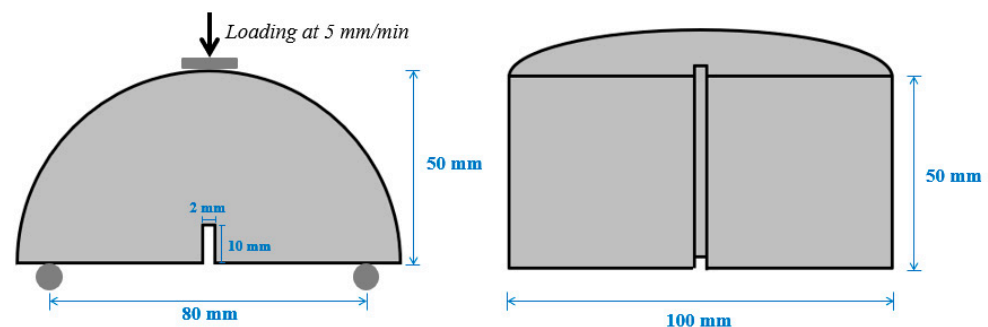

Figure 1. The semi-circular bending (SCB) sample dimensions.

2.2. Testing Methods

2.2.1. X-ray Computed Tomography

SWF can largely enhance the conductivity and microwave heating speed of asphalt mixture, but it can gather into clusters during asphalt mixing, which not only absorbs too much bitumen and decreases the mechanical properties of the mixture, but also causes uneven heating or overheating on the cluster region. X-ray computed tomography (XCT) was used to investigate the SWF distribution in the PA mix. To this aim, a Phoenix Nanotom CT scanner was employed, and the resolution was set as $20 \text{ }\mu\text{m}$.

2.2.2. Semi-Circular Bending Test

In this study, the SCB test was employed to investigate the fracture resistance of the PAC. The test was performed according to European norm EN 12697-44. The detailed test settings and the calculation of the maximum stress at failure can be referred to the previous work [26].

2.2.3. Microwave Healing

The microwave healing was performed on the damaged PAC samples with a microwave oven with the power of 1000 Watts at the frequency of 2.45 GHz, and the microwave oven had the inner size of 330 × 325 × 200 mm. An infrared camera was used to investigate the temperature profile of the specimen after microwave heating. The optimum microwave heating time needed to be determined before the healing test. To this aim, five SCB specimens (PA3) were heated in a microwave oven for 30, 45, 60, 75, and 90 s, respectively, and the highest surface temperatures of the heated specimens were recorded.

2.2.4. Bending and Healing Programme

Figure 2 shows images of an SCB specimen (PA1) after healing test and after bending test. An SCB bending and microwave healing programme was designed to evaluate the healing efficiency of each specimen:

1. First, the original mechanical properties of the specimen were studied with an SCB test.
2. Second, the fracture faces of the bent specimen were closed and heated in the microwave oven, and then conditioned at 23 °C for 20 h (Figure 2a).
3. Subsequently, the next SCB test was performed to acquire the regained mechanical properties of the specimen after microwave healing (Figure 2b).

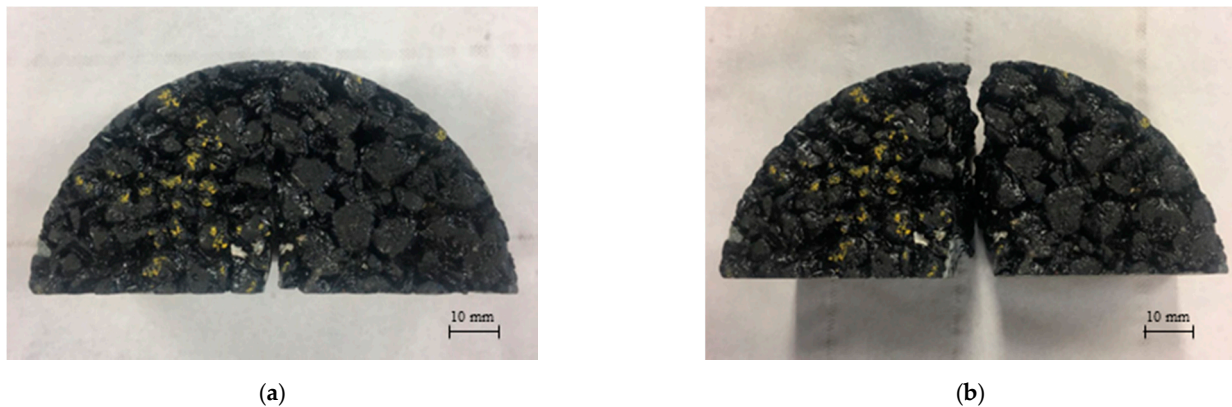

Figure 2. The SCB specimen: (a) before bending test (after healing) and (b) fractured after bending test.

Afterwards, step 2 and 3 were repeated, which were considered as a bending and healing cycle. The testing programme was completed after 6 bending and healing cycles, or when the peak load of the healed specimen was below 200 N. The microwave healing efficiency of each SCB specimen can be evaluated with the healing index (*HI*) calculated with the peak load acquired during the bending and healing programme in Equation (1):

$$HI = \frac{C_x}{C_1} \times 100 \quad (1)$$

where *HI* is the healing index (%), C_1 is the initial peak load (N), and C_x is the peak load measured from the *x* testing cycle (N). In this study, the healing efficiency of the microwave healing system can be compared with the other asphalt self-healing systems, including the calcium alginate capsules healing system, the induction healing system, and the combined healing system.

3. Results and Discussion

3.1. X-CT Test Results

Figure 3 presents the SWF distribution in a PAC sample with mixture PA3, where the yellow particles in the CT scan image (on the right) illustrate the positions of the steel fibres in the PA cylinder (on the left). This indicates that when 6% steel fibres are added, they are homogeneously distributed in the PA mix, since no significant cluster is found.

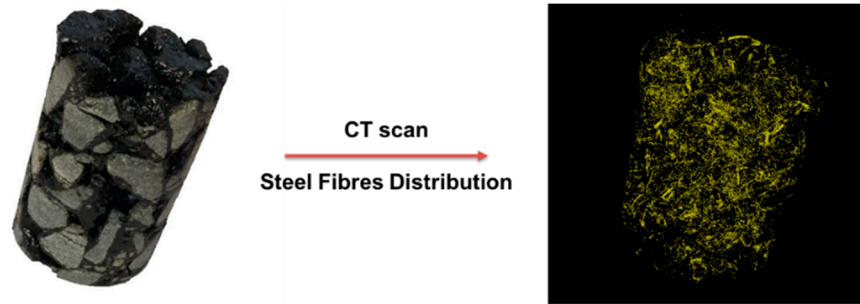
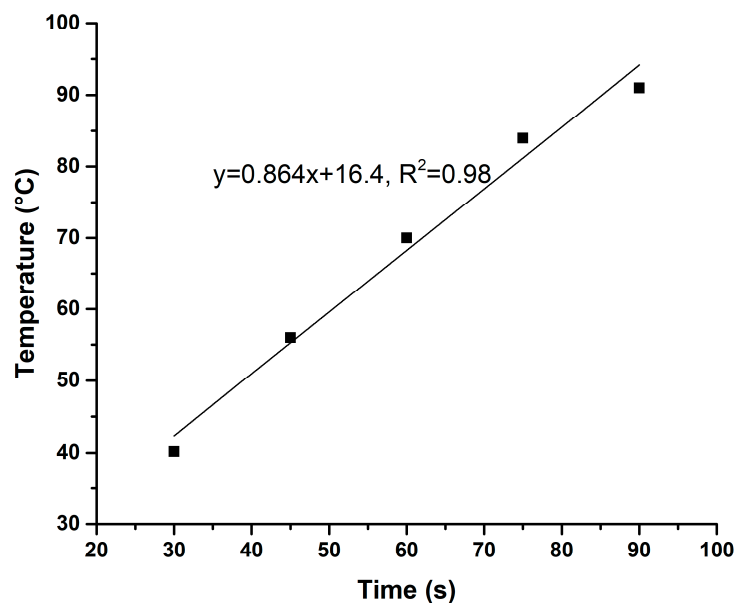

Figure 3. Steel Wool Fibre (SWF) distribution study with XCT.

3.2. Microwave Heating Effect

Figure 4a shows the highest surface temperature of the microwave heated specimens with mix PA3 after different heating times. It was found that a microwave heating period of 75 s leads to the highest surface temperature at 84 °C, which almost reaches the optimum temperature for thermally induced crack-healing behaviour [14], and as such the microwave heating time was determined as 75 s. Figure 4b shows the average temperature measured from the infrared camera during all microwave healing cycles. The dash lines in Figure 4b show the average healing temperatures of SCB specimens from groups PA1, PA2, and PA3, which are 60.4, 97.3, and 77.1 °C, respectively. The specimens in group PA2 had the highest microwave heating temperature, which might be due to it having the greatest steel fibre content among the three test groups. For the same reason, PA3 showed a higher microwave heating temperature than PA1.



(a)

Figure 4. Cont.

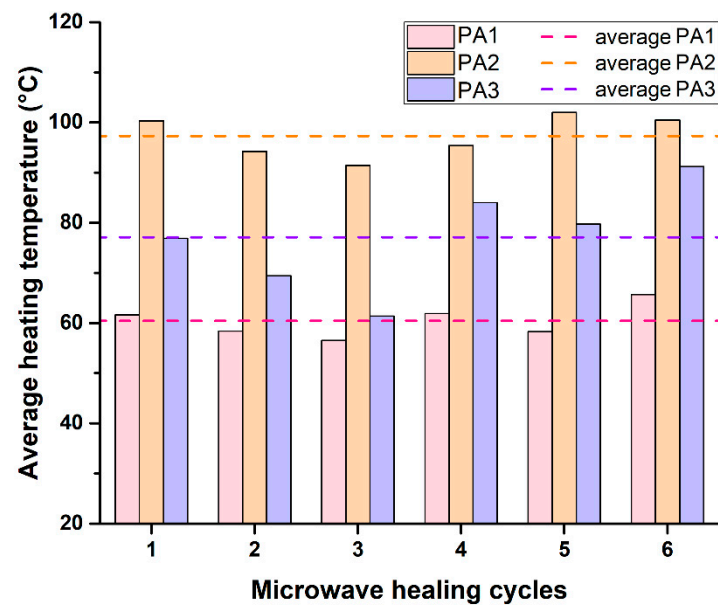

(b)

Figure 4. Maximum temperature after microwave heating: (a) temperature vs. heating time and (b) maximum temperature during healing cycles.

Figure 5 illustrates the temperature distribution of SCB specimens with different mixture types after microwave heating. Although PA1 (Figure 5a) showed a lower heating temperature than PA2 and PA3, its temperature was more evenly distributed and did not show a temperature concentration area, as was presented in the other two groups (Figure 5b,c). Besides, it is noticed that the temperature inside the sample can be much higher than on the surface, and this is found in both Figure 5b,c, where some areas behind the surface aggregate exhibit brighter colours. As such, the microwave heating technique can potentially achieve damage healing beneath the surface of the asphalt mixture.

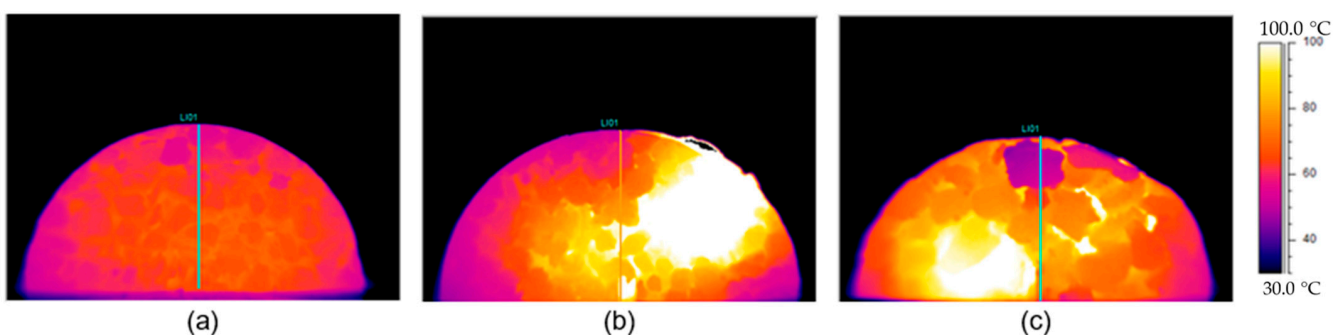
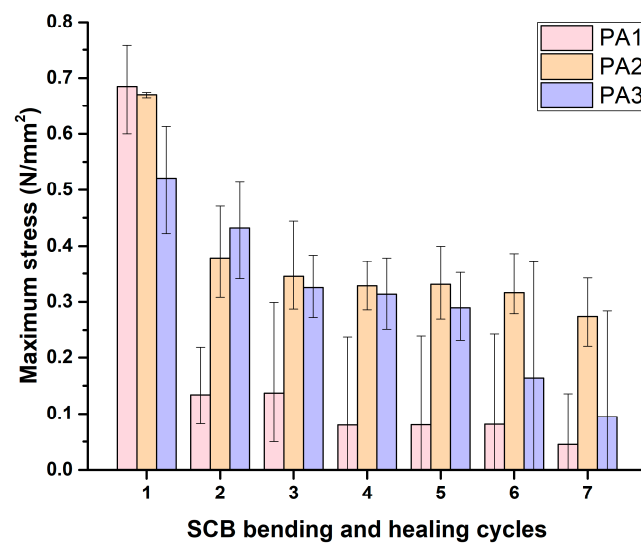

Figure 5. The SCB specimens with different mixture types after microwave heating: (a) PA1, (b) PA2, and (c) PA3.

3.3. Fracture Properties of the Porous Asphalt Concrete with Capsules

Figure 6 presents the development of the maximum stress of SCB specimens during the bending and healing cycles. Figure 6a shows that PA1 and PA2 have much higher initial maximum stress than PA3, which indicates porous asphalt mixture with finer aggregates has a higher fracture resistance. During the SCB bending and healing tests, some specimens from group PA1 could not gain any strength from microwave healing after the third bending test, and the maximum stress of these specimens was regarded as 0 MPa in the following cycles, which caused scattered results of group PA1 from cycle 4. The same situation was

also found in group PA3, where some specimens could not be healed after the 5th cycle. In comparison, all specimens from group PA2 could regain a maximum stress around 0.3 MPa after all the microwave healing cycles. Moreover, the regained strength in PA1 after cycle 2, was significantly lower than that in PA2 and PA3, and this finding might be related to the microwave heating temperature shown in Figure 5b, as well as the steel fibre content in the PA mix (Table 1). Figure 6b presents the healing index of all three testing groups during the bending and healing test cycles, which shows a similar trend as the maximum stress. It was found that PA1 had the lowest healing efficiency, and PA3 showed a rapid decrease of healing index at the 6th cycle, which might be due to the unrecoverable specimens in group PA3.



(a)

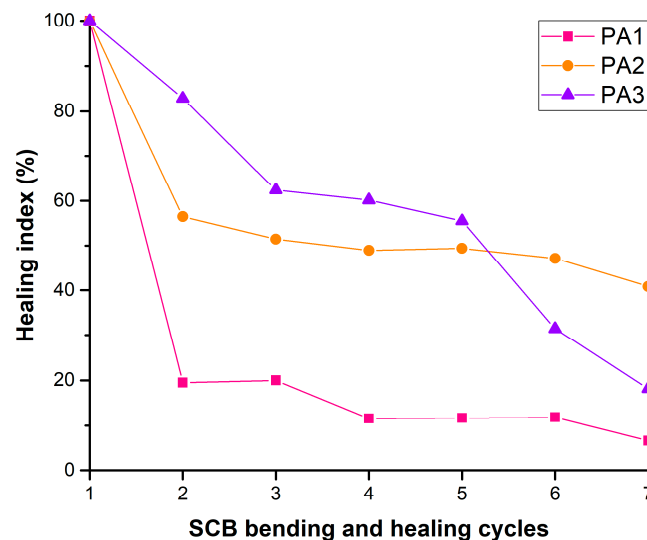

(b)

Figure 6. The development of fracture resistance of SCB specimens during the bending and healing tests: (a) the average maximum stress and (b) the healing index.

3.4. Characteristics of the Microwave Healing System

Figure 7 shows the side effects of microwave heating on the healed specimens. Figure 7a shows the image of SCB specimen from group PA2 whose bitumen overflowed out of the surface after microwave heating, which might be due to the heat concentration

inside of the asphalt mixture. Figure 7b summarises the vertical deformation of all the specimens after all the bending and healing cycles. Specimens from group PA3 contained larger particles in the mix and showed the highest vertical deformation. The deformation of specimens in group PA2 was higher than those in PA1, which might be because of the higher microwave heating temperature for specimens in PA2. A change in asphalt structure during microwave heating was also reported by Norambuena-Contreras et al. [8].

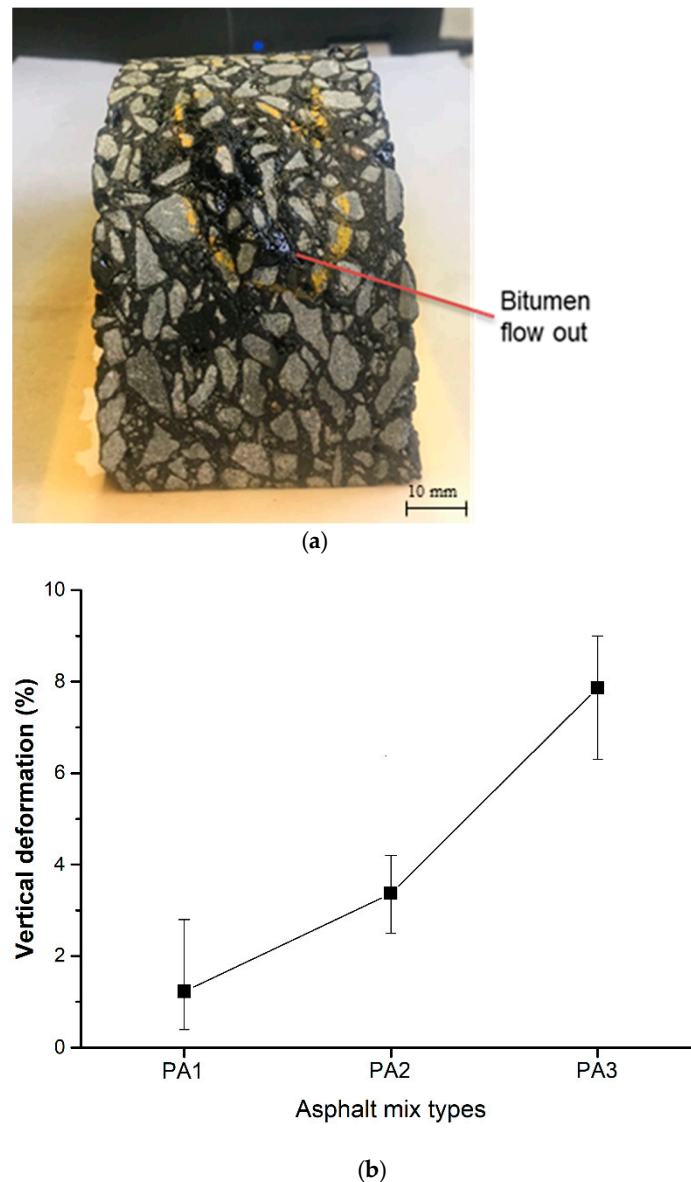

Figure 7. The side effects of microwave heating: (a) bitumen flow out and (b) the vertical deformation after all testing cycles.

Figure 8 shows the crack healing efficiency of microwave healing systems in comparison with other healing systems reported in previous works [26,27]. In Figure 8, the healing index of specimens from group PA3 is used to represent the healing efficiency of microwave healing systems, which followed the same mix design principle—gradations, void content, bitumen type, etc.—as the other healing systems. This indicates that when heated up to the same surface maximum temperature, the microwave healing showed lower efficiency than the induction healing when tested on the same mix without laboratory ageing. Moreover, this microwave healing efficiency was lower than the induction healing system and combined healing system with laboratory aged mixture in most of the healing

cycles. This might be due to the uneven heating effect from microwaves, which means the damaged area is not always covered by the high-temperature region from microwave heating, and this uneven heating could further change the void distribution in the PA mix.

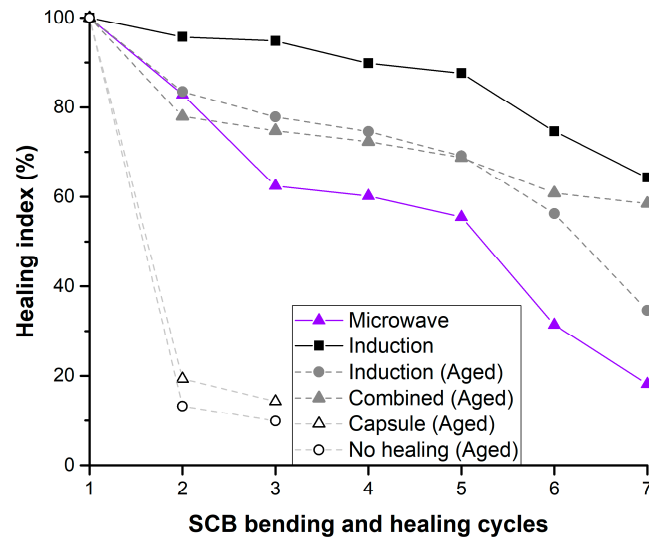

Figure 8. The healing efficiency of microwave healing systems in comparison with other healing systems.

Figure 9 shows the infrared images of a PAC specimen during induction heating, which indicates that although the induction heating has a gradient heating effect, the temperature distribution is more homogeneous than that of microwave heating. Accordingly, the induction healing effect is more stable [29].

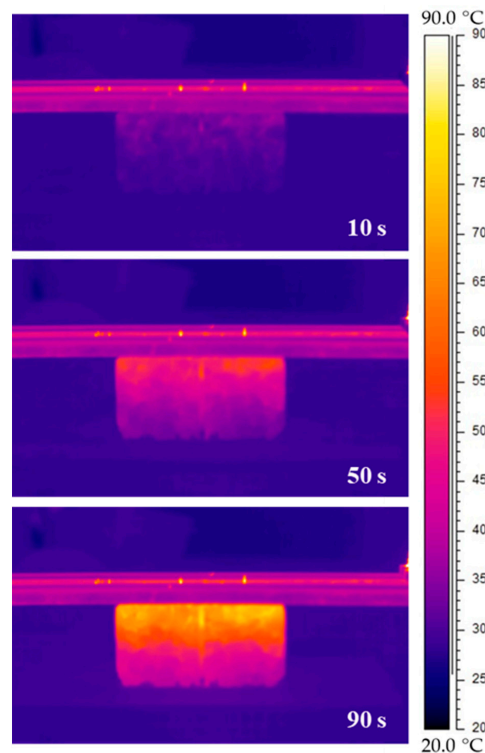

Figure 9. The temperature distribution of porous asphalt concrete (PAC) specimen in the induction heating test [27].

However, since the microwave heating technique can heat up the asphalt structure below the surface, it is believed that if the microwave is guided to focus on the damaged site, the microwave healing system can be an effective supplement for induction healing to achieve deeper damage repairing in asphalt.

4. Conclusions

This study investigated the healing effect of the microwave heating method on three different porous asphalt mixes. The results show the great potential of microwave healing; however, the results also highlighted some side effects of this asphalt healing method. The following conclusions are drawn:

- The optimum microwave heating time may differ for different asphalt mixes, which is related to the mixture type and the steel fibre content. It is possible to raise the surface temperature of the standard porous asphalt 0/11 incorporating 6% steel fibres to around 80 °C in 75 s. The temperature profiles of the asphalt specimens also indicate that, in the same microwave heating condition (power, frequency, time, etc.), the heating temperature is proportional to the steel fibre content.
- Microwave heating contributes to the crack healing in PAC, but it can also change the void structure of the PAC. This also indicates that larger aggregates or higher steel fibre contents may lead to a higher vertical deformation after microwave heating.
- Microwaves could also have an uneven heating effect on the asphalt mixture, which may lead to a heterogeneous temperature distribution of the tested specimen, and could even cause bitumen to flow out of the asphalt mixture due to overheating. However, this finding proves that microwaves can heat up the inner part of the asphalt structure and therefore repair damage at deeper sites.
- Aimed at the same maximum surface heating temperature, the microwave healing system is less efficient than the induction healing system.

In general, as an induced healing method, microwave heating can achieve fast heating and effective crack healing in asphalt concrete. However, due to its negative effects, such as uneven heating, change in void structure, and causing the bitumen to flow out, the current microwave heating technique can hardly be used as the prime asphalt self-healing mechanism. As such, it is suggested to use microwave healing as a supplement for the combined healing system to solve the potential practical problems from induction healing—i.e., limited heating depth and heating speed.

Author Contributions: S.X., A.T., X.L. and E.S. conceived and designed the experiments; S.X. performed the experiments and analysed the data; S.X., A.T., X.L. and E.S. wrote the paper. All authors have read and agreed to the published version of the manuscript.

Funding: This research was funded by China Scholarship Council, grant number 201506950066.

Institutional Review Board Statement: Not applicable.

Informed Consent Statement: Not applicable.

Data Availability Statement: The raw/processed data required to reproduce these findings cannot be shared at this time as the data also forms part of an ongoing study.

Acknowledgments: The support from Heijmans in asphalt slab preparation is greatly appreciated. The authors wish also to thank H. Wang, M. Laot, R. Zandonella, G.W.H. Hoekman, and the technicians from Microlab and the section of pavement engineering of TUDelft for their help in this study.

Conflicts of Interest: The authors declare no conflict of interest.

References

1. Francken, L. Fatigue performance of a bituminous road mix under realistic test conditions. *Transp. Res. Rec.* **1979**, 30–37.
2. Castro, M.; Sánchez, J.A. Fatigue and healing of asphalt mixtures: Discriminate analysis of fatigue curves. *Transp. Eng. J. ASCE* **2006**, *132*, 168–174. [[CrossRef](#)]
3. Little, D.N.; Bhasin, A. Exploring Mechanism of Healing in Asphalt Mixtures and Quantifying its Impact. In *Self Healing Materials*; Springer: Berlin/Heidelberg, Germany, 2007; pp. 205–218.
4. Williams, D.; Little, D.; Lytton, R.; Kim, Y.; Kim, Y. *Microdamage Healing in Asphalt and Asphalt Concrete, Volume 2: Laboratory and Field Testing to Assess and Evaluate Microdamage and Microdamage Healing*; Turner-Fairbank Highway Research Center: Georgetown Pike, McLean, VA, USA, 2001.
5. Sarsam, S.I. Crack healing potential of asphalt concrete pavement. *Int. J. Sci. Res. Knowl.* **2015**, *3*, 1–12. [[CrossRef](#)]
6. Grant, T.P. *Determination of Asphalt Mixture Healing Rate Using the Superpave Indirect Tensile Test*; University of Florida USA: Gainesville, FL, USA, 2001.
7. Qiu, J. *Self Healing of Asphalt Mixtures: Towards a better Understanding of the Mechanism*; Delft University of Technology: Delft, The Netherlands, 2012.
8. Norambuena-Contreras, J.; Garcia, A. Self-healing of asphalt mixture by microwave and induction heating. *Mater. Des.* **2016**, *106*, 404–414. [[CrossRef](#)]
9. Liu, Q.; García, Á.; Schlangen, E.; van de Ven, M. Induction healing of asphalt mastic and porous asphalt concrete. *Constr. Build. Mater.* **2011**, *25*, 3746–3752. [[CrossRef](#)]
10. Liu, Q. *Induction Healing of Porous Asphalt Concrete*; Delft University of Technology: Delft, The Netherlands, 2012.
11. Liu, Q.; Schlangen, E.; van de Ven, M.F.; van Bochove, G.; van Montfort, J. Predicting the Performance of the Induction Healing Porous Asphalt Test Section. In Proceedings of the 7th RILEM International Conference on Cracking in Pavements, Delft, The Netherlands, 20–22 June 2012; pp. 1081–1089.
12. García, Á.; Schlangen, E.; van de Ven, M.; van Vliet, D. Induction heating of mastic containing conductive fibers and fillers. *Mater. Struct.* **2011**, *44*, 499–508. [[CrossRef](#)]
13. Apostolidis, P.; Liu, X.; Scarpas, A.; Kasbergen, C.; van de Ven, M. Advanced evaluation of asphalt mortar for induction healing purposes. *Constr. Build. Mater.* **2016**, *126*, 9–25. [[CrossRef](#)]
14. Xu, S.; García, A.; Su, J.; Liu, Q.; Tabaković, A.; Schlangen, E. Self-Healing Asphalt Review: From Idea to Practice. *Adv. Mater. Interfaces* **2018**, 1800536. [[CrossRef](#)]
15. Zhu, X.; Cai, Y.; Zhong, S.; Zhu, J.; Zhao, H. Self-healing efficiency of ferrite-filled asphalt mixture after microwave irradiation. *Constr. Build. Mater.* **2017**, *141*, 12–22. [[CrossRef](#)]
16. González, A.; Valderrama, J.; Norambuena-Contreras, J. Microwave crack healing on conventional and modified asphalt mixtures with different additives: An experimental approach. *Road Mater. Pavement Design* **2019**, *20*, S149–S162. [[CrossRef](#)]
17. Zhao, H.; Zhong, S.; Zhu, X.; Chen, H. High-efficiency heating characteristics of ferrite-filled asphalt-based composites under microwave irradiation. *J. Mater. Civil. Eng.* **2017**, *29*, 04017007. [[CrossRef](#)]
18. Gallego, J.; del Val, M.A.; Contreras, V.; Páez, A. Heating asphalt mixtures with microwaves to promote self-healing. *Constr. Build. Mater.* **2013**, *42*, 1–4. [[CrossRef](#)]
19. Norambuena-Contreras, J.; Serpell, R.; Vidal, G.V.; González, A.; Schlangen, E. Effect of fibres addition on the physical and mechanical properties of asphalt mixtures with crack-healing purposes by microwave radiation. *Constr. Build. Mater.* **2016**, *127*, 369–382. [[CrossRef](#)]
20. Gao, J.; Sha, A.; Wang, Z.; Tong, Z.; Liu, Z. Utilization of steel slag as aggregate in asphalt mixtures for microwave deicing. *J. Clean. Prod.* **2017**, *152*, 429–442. [[CrossRef](#)]
21. Phan, T.M.; Park, D.-W.; Le, T.H.M. Crack healing performance of hot mix asphalt containing steel slag by microwaves heating. *Constr. Build. Mater.* **2018**, *180*, 503–511. [[CrossRef](#)]
22. Wang, H.; Zhang, Y.; Zhang, Y.; Feng, S.; Lu, G.; Cao, L. Laboratory and numerical investigation of microwave heating properties of asphalt mixture. *Materials* **2019**, *12*, 146. [[CrossRef](#)] [[PubMed](#)]
23. Li, C.; Wu, S.; Chen, Z.; Tao, G.; Xiao, Y. Enhanced heat release and self-healing properties of steel slag filler based asphalt materials under microwave irradiation. *Constr. Build. Mater.* **2018**, *193*, 32–41. [[CrossRef](#)]
24. Wang, Z.; Dai, Q.; Porter, D.; You, Z. Investigation of microwave healing performance of electrically conductive carbon fiber modified asphalt mixture beams. *Constr. Build. Mater.* **2016**, *126*, 1012–1019. [[CrossRef](#)]
25. Karimi, M.M.; Jahanbakhsh, H.; Jahangiri, B.; Nejad, F.M. Induced heating-healing characterization of activated carbon modified asphalt concrete under microwave radiation. *Constr. Build. Mater.* **2018**, *178*, 254–271. [[CrossRef](#)]
26. Xu, S.; Liu, X.; Tabaković, A.; Schlangen, E. A novel self-healing system: Towards a sustainable porous asphalt. *J. Clean. Prod.* **2020**, 120815. [[CrossRef](#)]
27. Xu, S.; Liu, X.; Tabaković, A.; Schlangen, E. The influence of asphalt ageing on induction healing effect on porous asphalt concrete. *RILEM Tech. Lett.* **2018**, *3*, 98–103. [[CrossRef](#)]
28. Xu, S.; Liu, X.; Tabaković, A.; Schlangen, E. Investigation of the Potential Use of Calcium Alginate Capsules for Self-Healing in Porous Asphalt Concrete. *Materials* **2019**, *12*, 168. [[CrossRef](#)] [[PubMed](#)]
29. Xu, S. *Self-Healing Porous Asphalt: A Combination of Encapsulated Rejuvenator and Induction Heating*; Delft University of Technology: Delft, The Netherlands, 2020.