

# Edge On The

- A study into social integration  
within community boundaries

Graduation Studio ADC 2022/23  
2023/06/30

Deying Chen  
5504295

## Motivation

London is a place like that. It divide up in little worlds, and you stay in the world you belong to and you don't know anything about what happening in the other ones... them people who have car, who going to theater and ballet in the West End... they don't know nothing about hustling two pound of brussel sprout and half-pound potato, or queueing up for fish and chips in the smog.

– “The Lonely Londoners”,  
Sam Selvon

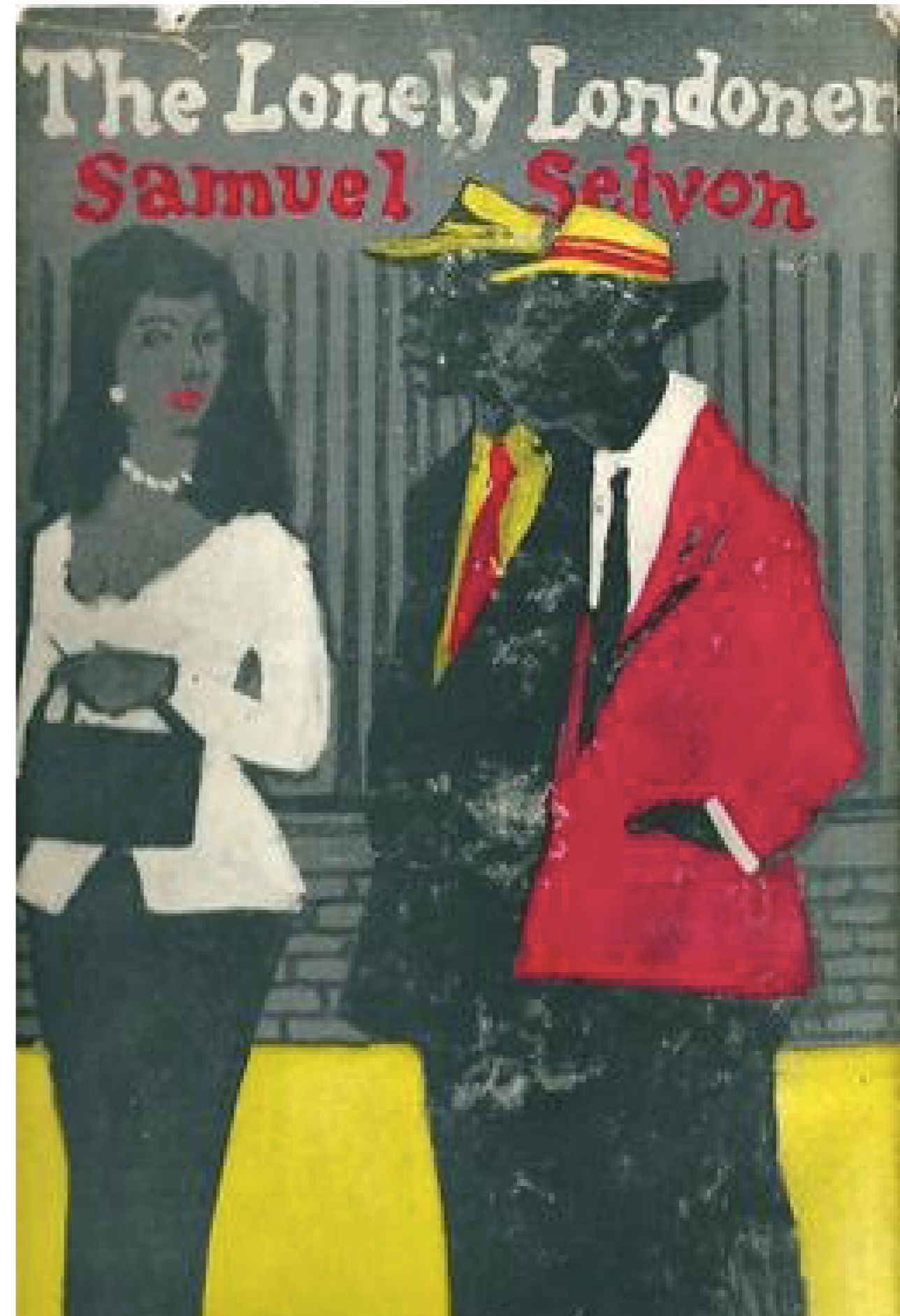



# West Tower Hamlets

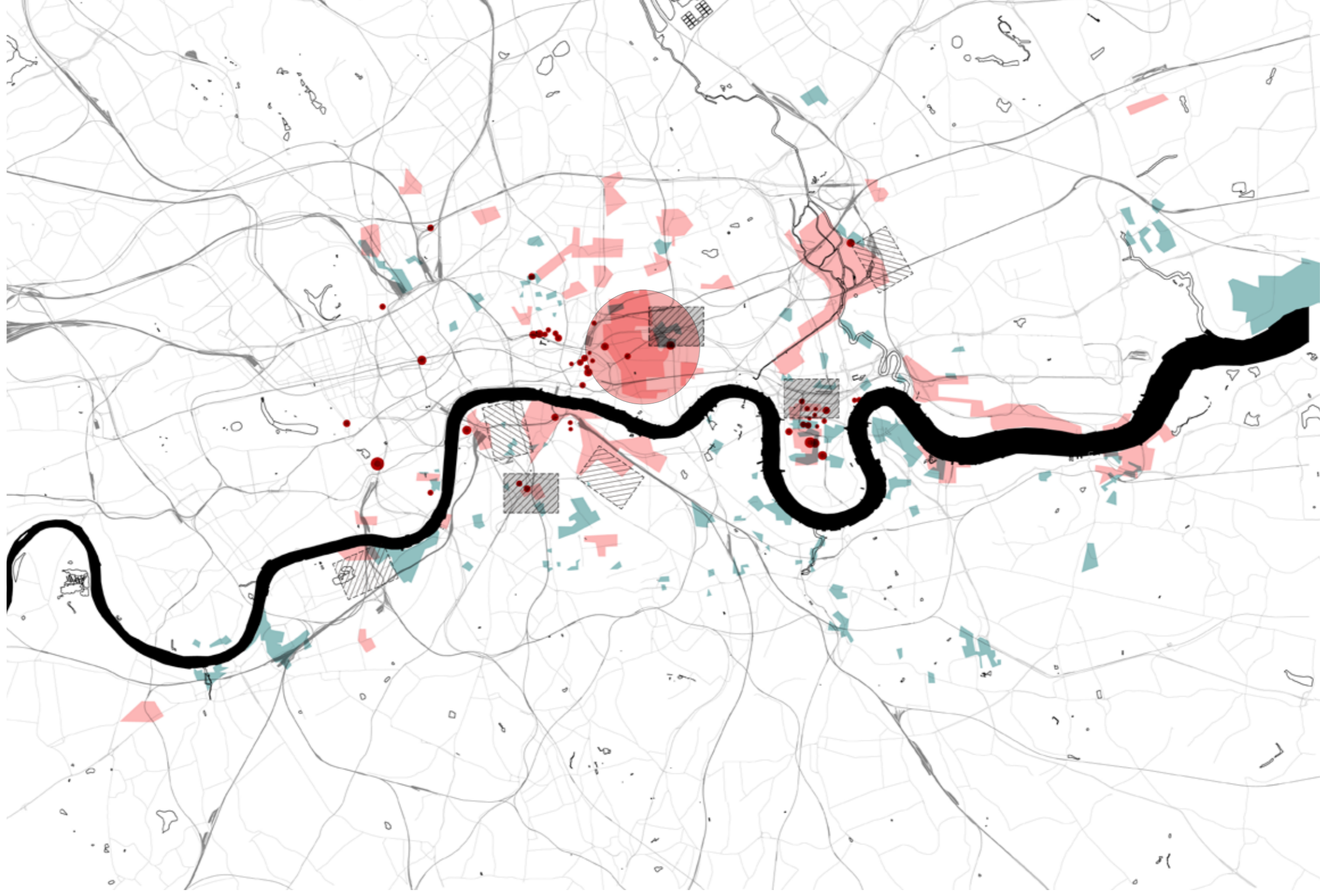

# Social Economic Edge





# Morphological Edge



# Demographic Edge





# Thick Description

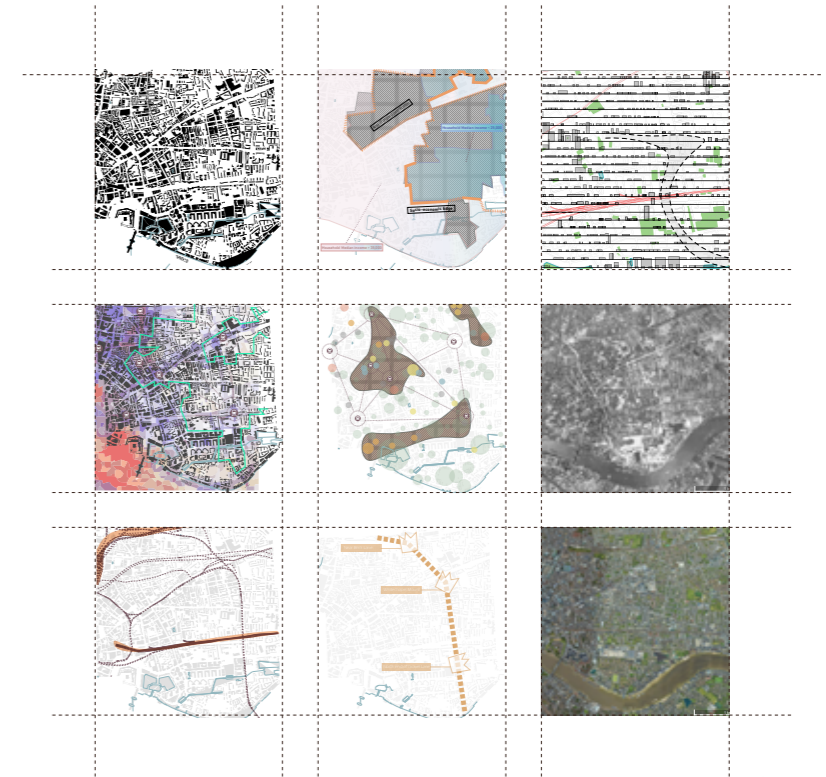
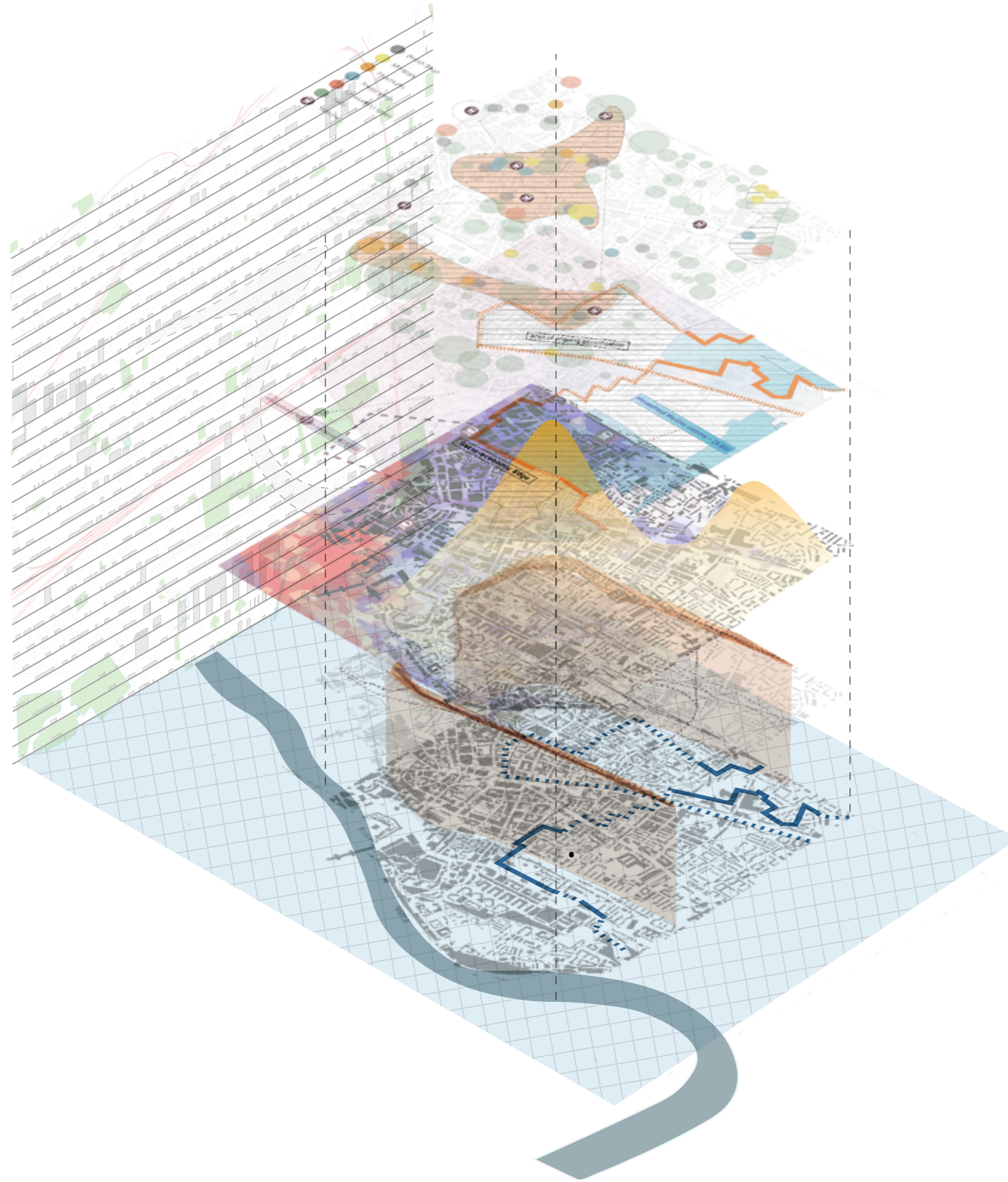

1 2 3  
4 5 6  
7 5 9

- 1 Urban fabric
- 2 Socio-economic edge
- 3 Morphological edge
- 4 Demographic edge
- 5 Social infrastructural edge
- 6 Historic satellite
- 7 Physical infrastructural edge
- 8 Historic edge
- 9 Current satellite

# Porosity

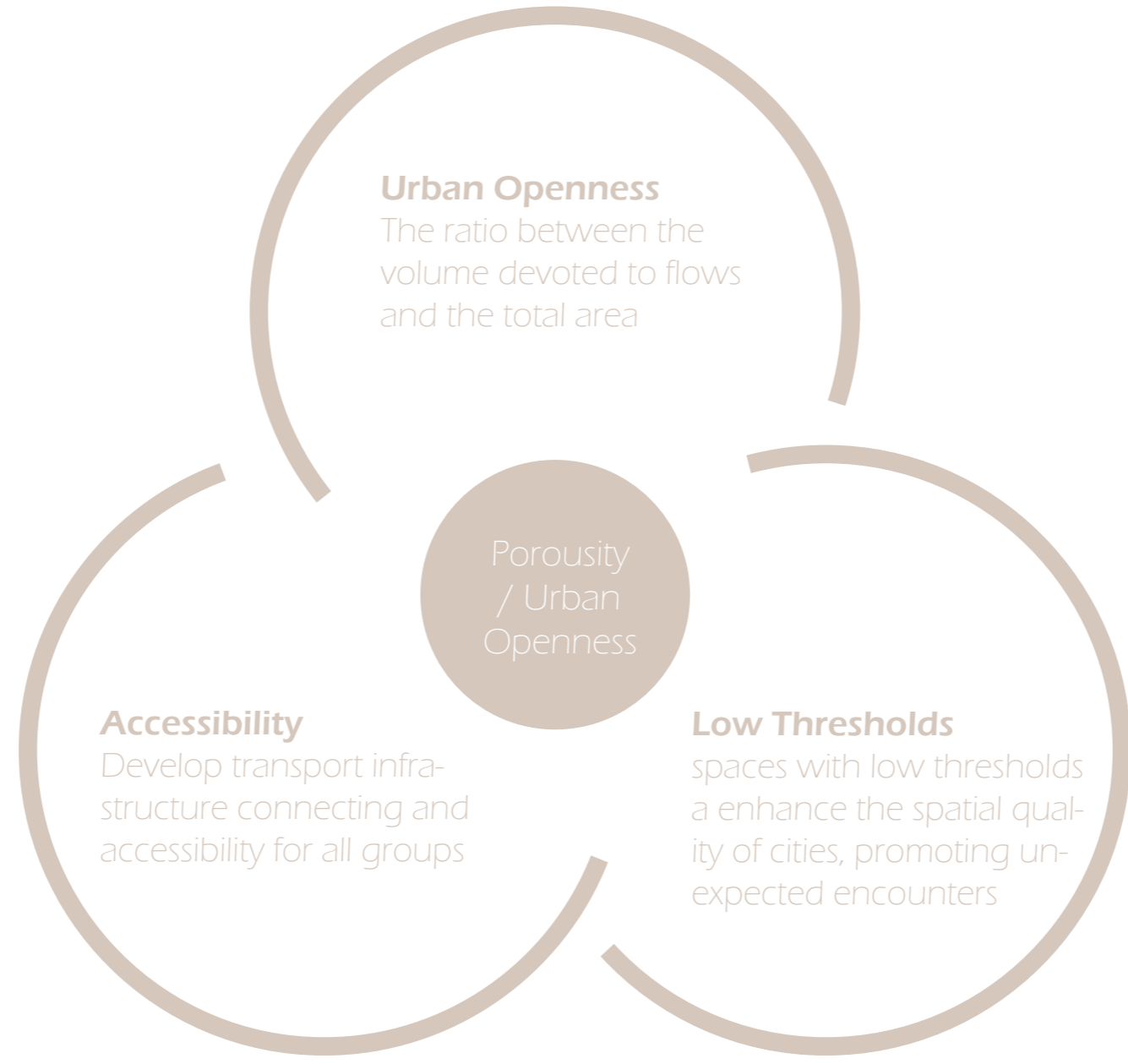

# Site Selection

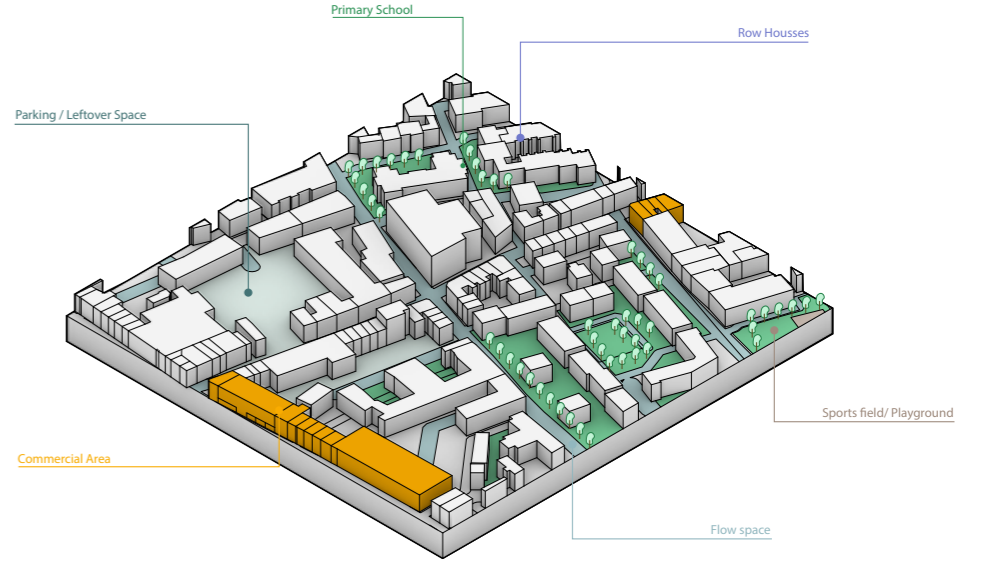
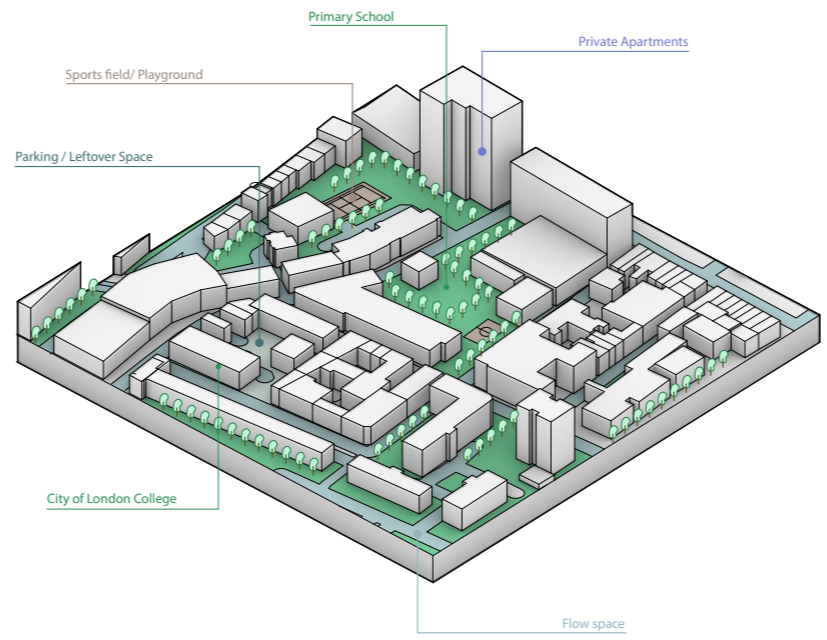
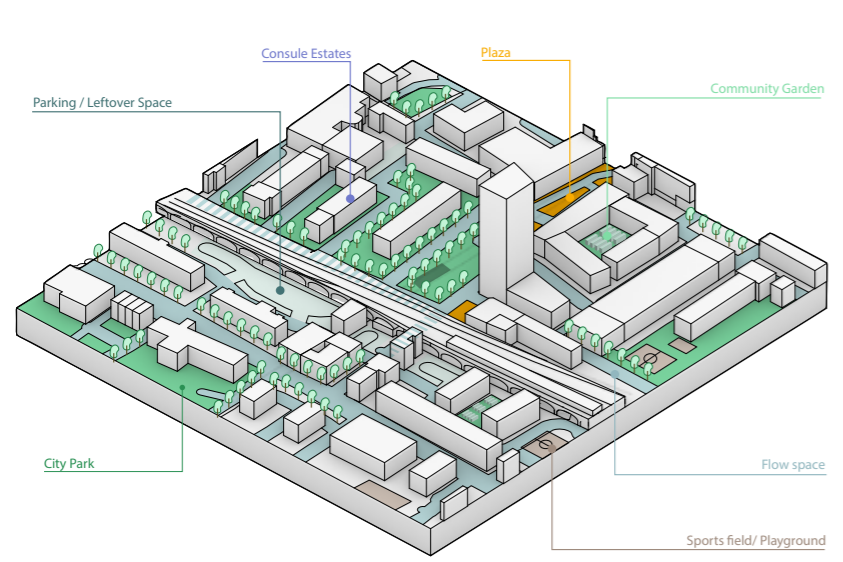



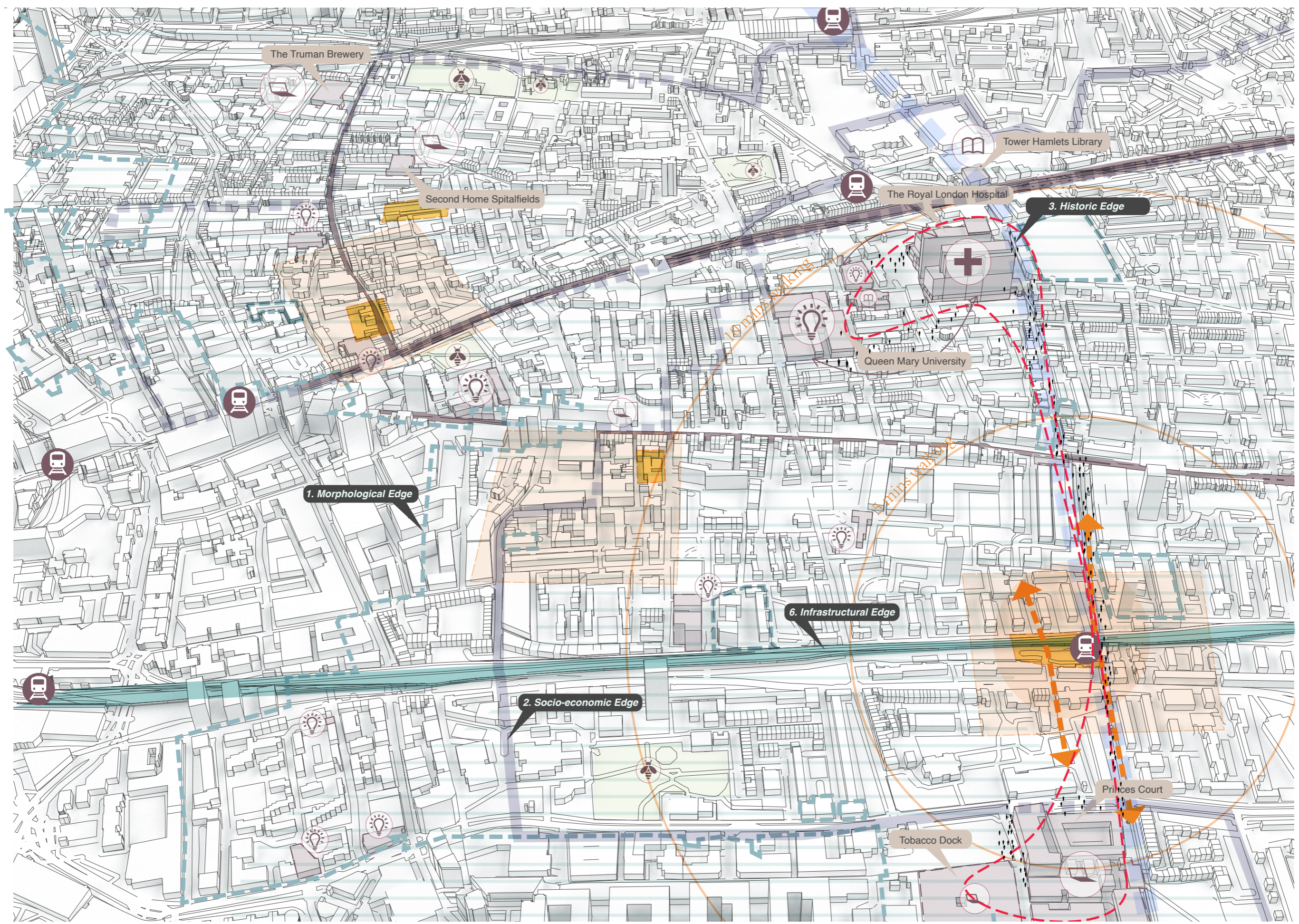



# Actors Network

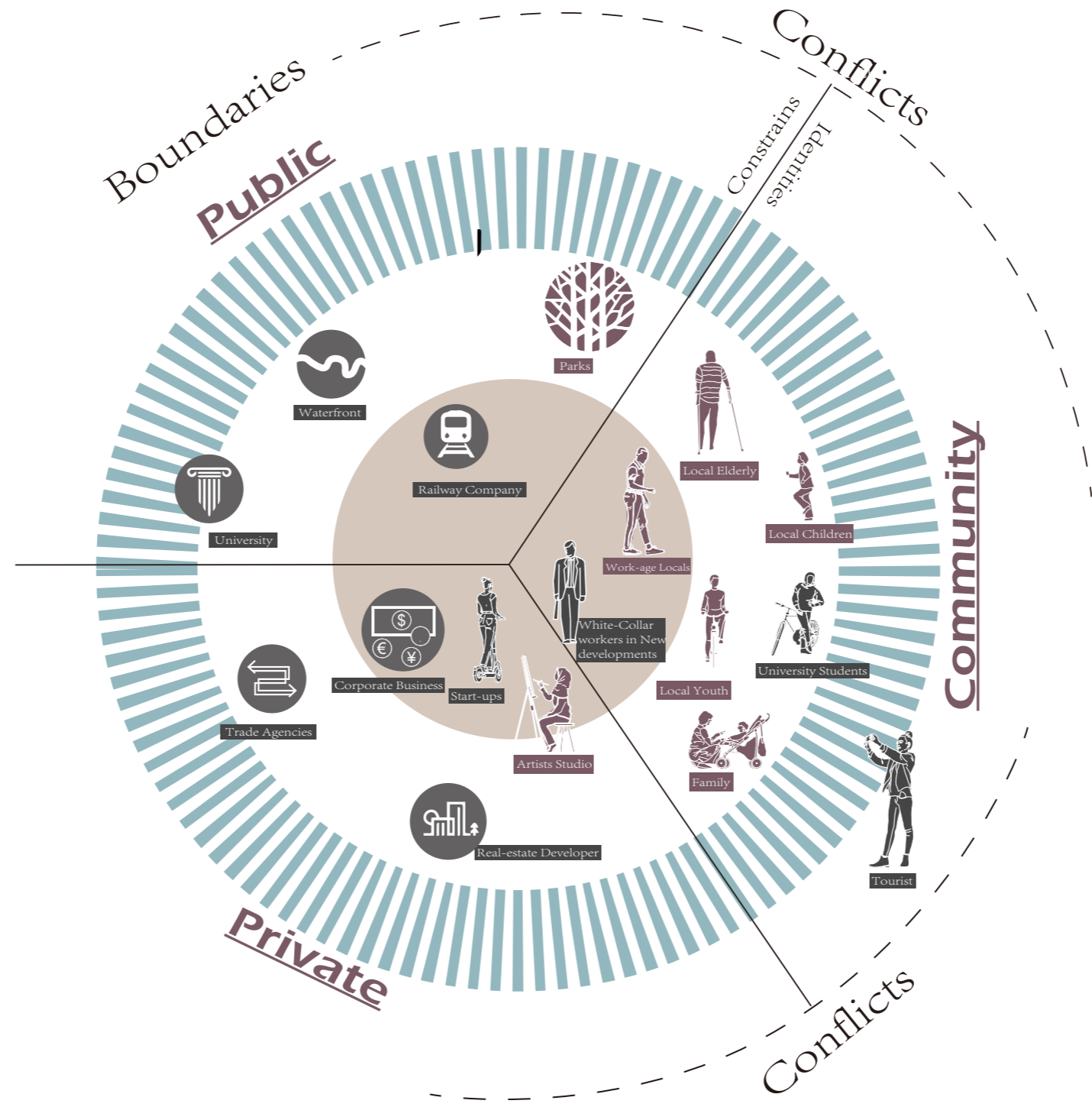

# Strategies

1. Interpenetration, superimposition and multilayering of spaces
2. Integration, overlapping and communication of spatial elements
3. Ambiguous zone, in between space, and threshold
4. Permeability, spaciousness, and ambiguity of borders
5. Coexistence, polyvalence, and sharing

# Site Plan

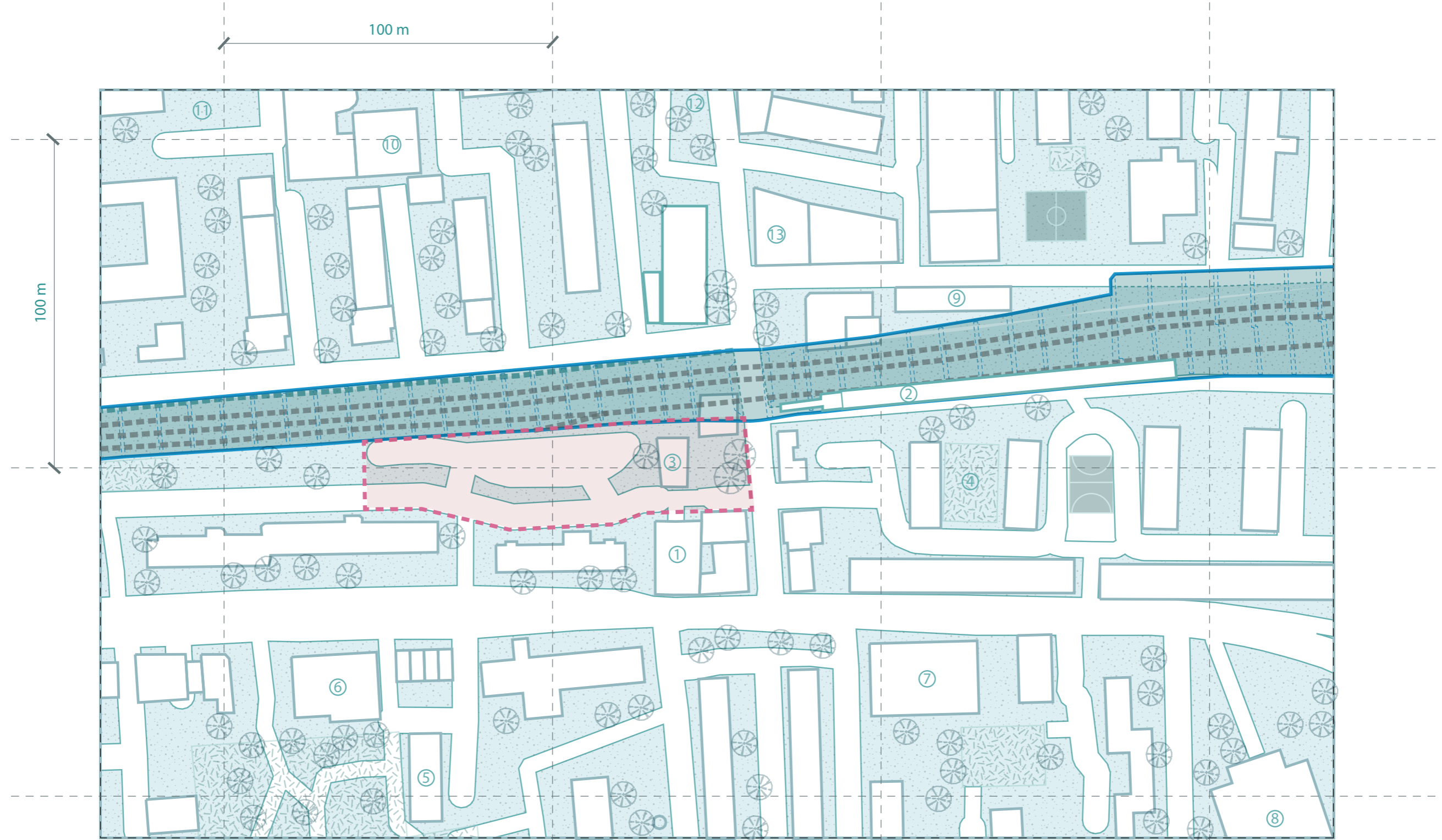

- 1. Shadwell Station (overground)
- 2. Shadwell Station (DLR)
- 3. Old Shadwell Station (current restaurant)
- 4. Shadwell gardens
- 5. The Greek Online School
- 6. St Georges Town Hall
- 7. Shadwell Fire Station
- 8. Blue Gate Fields Junior School
- 9. Shadwell Jame Masjid
- 10. Jamiatul Ummah School
- 11. Bigland Street Community Center
- 12. Watney Market
- 13. Kelday Heights Apartment

# Site Programs

P5 PRESENTATION

ADC 2022/2023

June 30th, 2023

5504295

Deying Chen

14

100 m

100 m





# Site Historic Photo

15





# Site Condition

16





# Urban Strategy

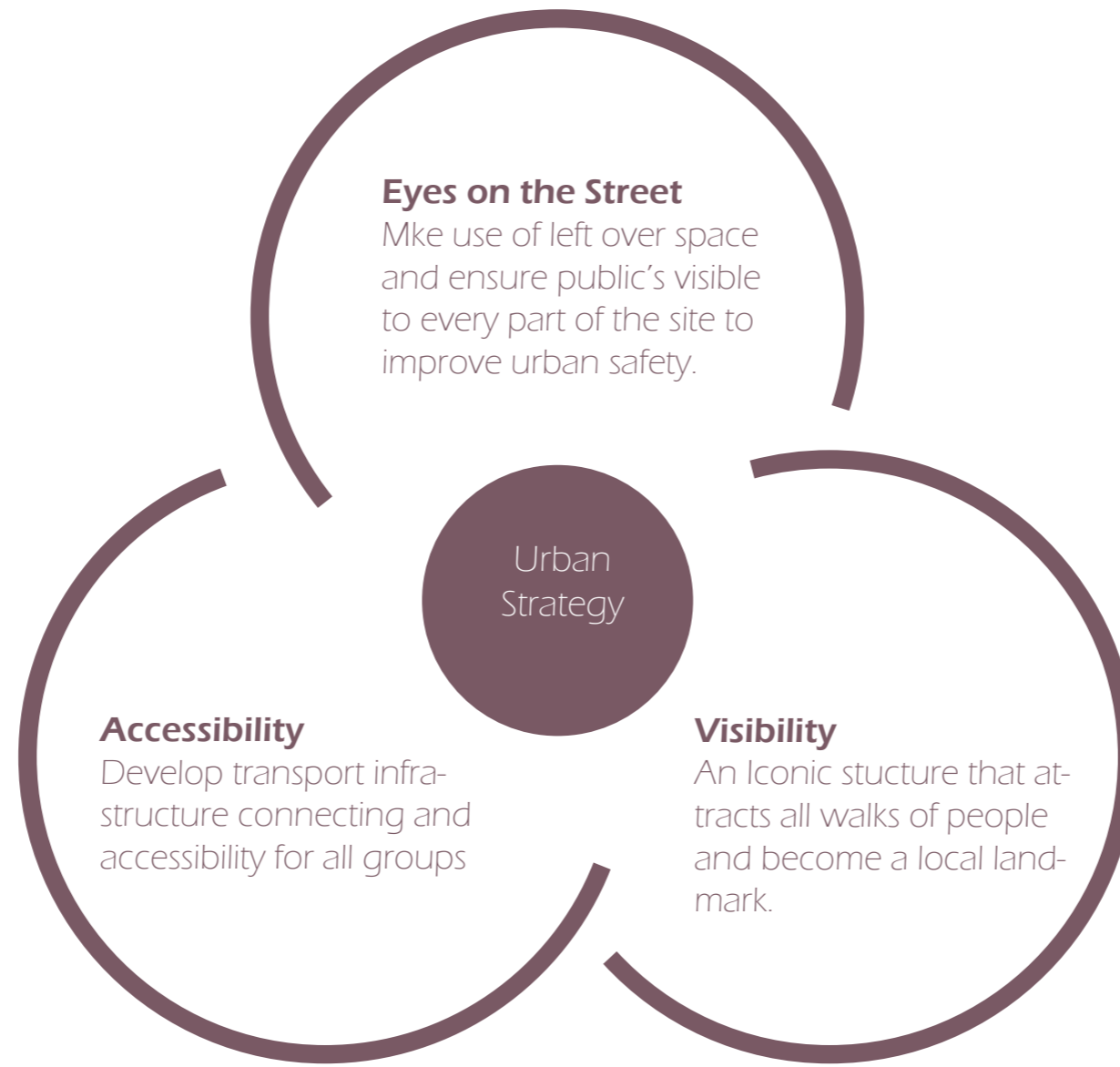

# 1. Accessibility - Site condition

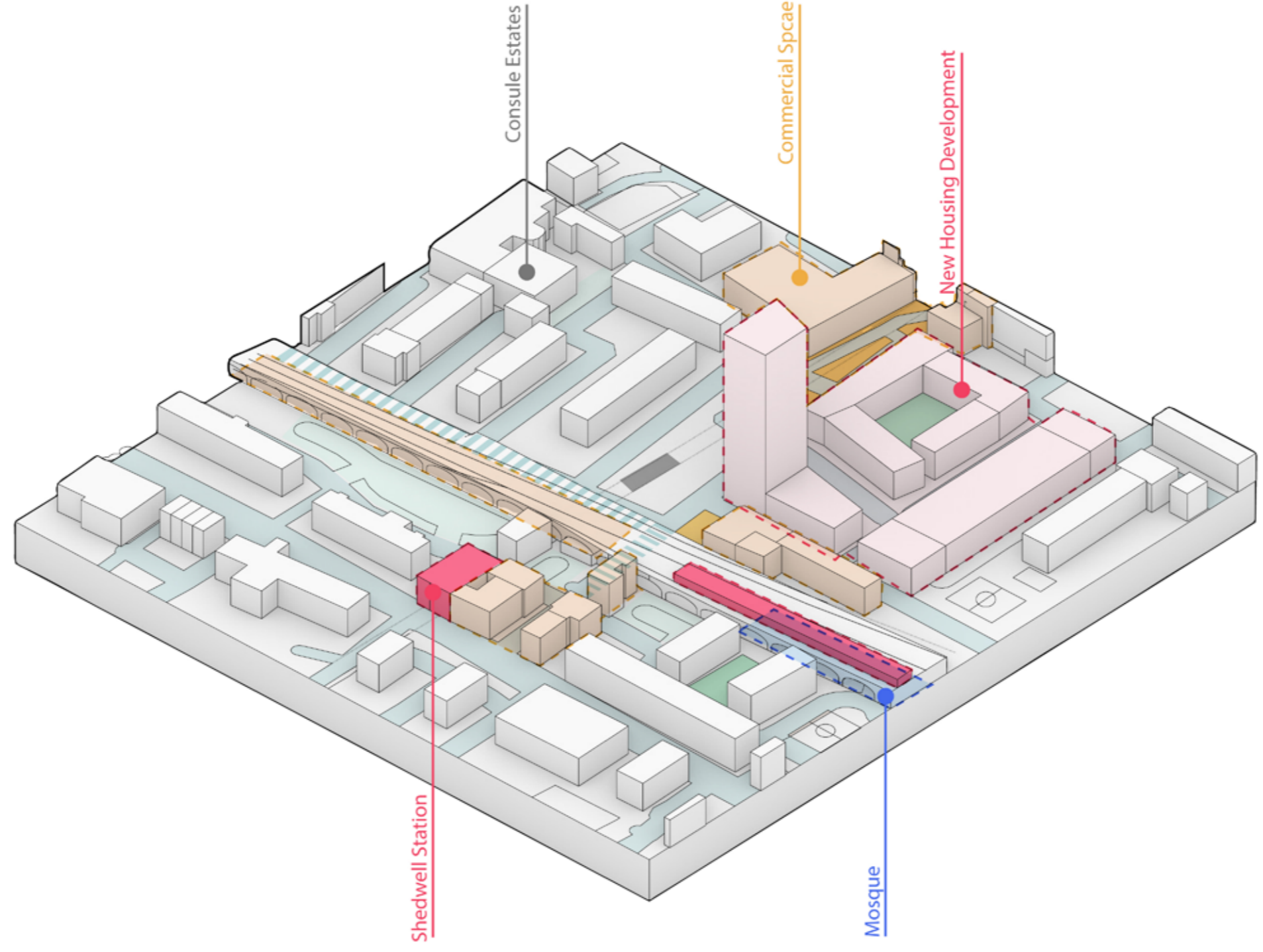



# 1. Accessibility - Circulation

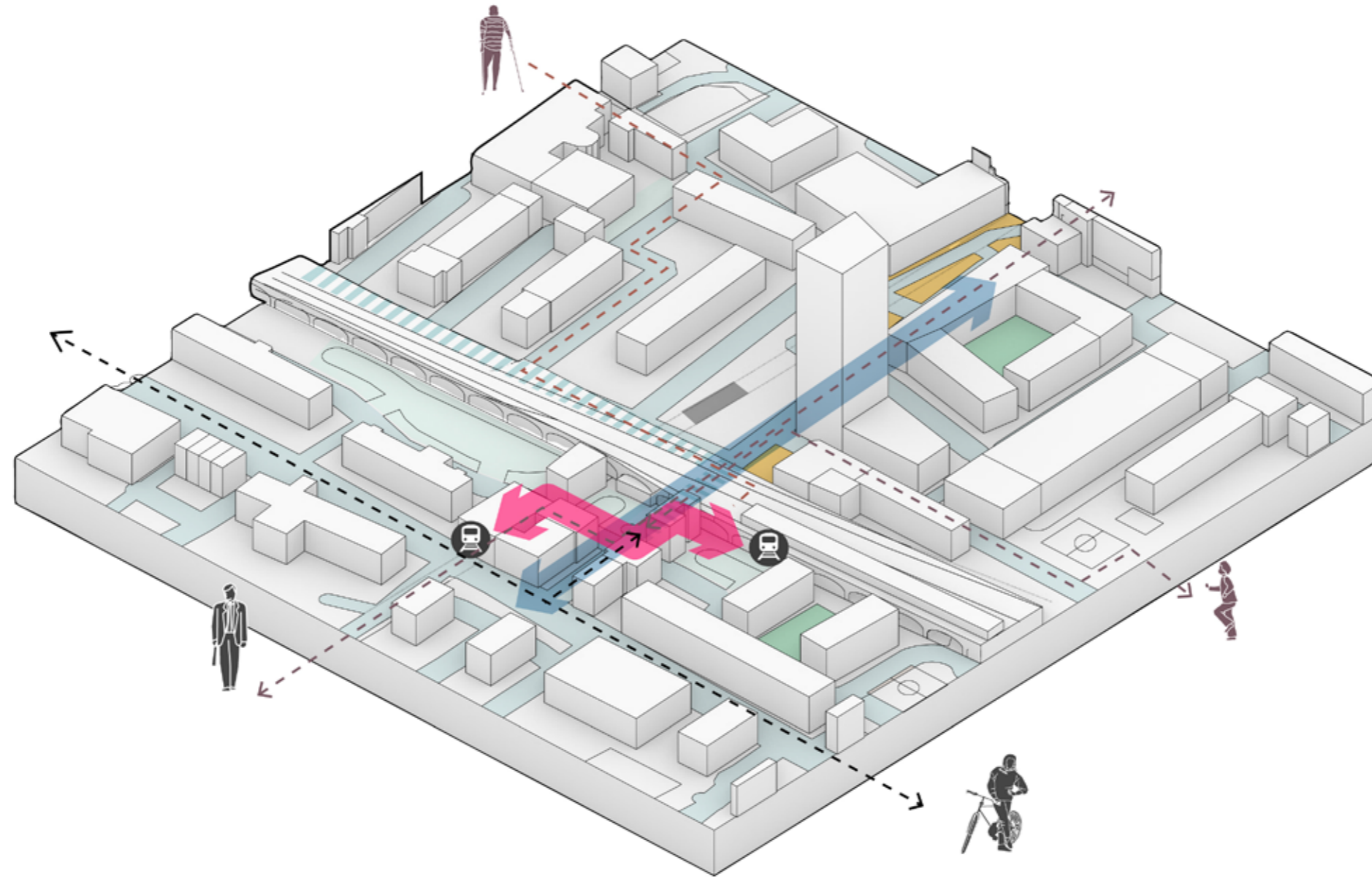

# 1. Accessibility - Strategy

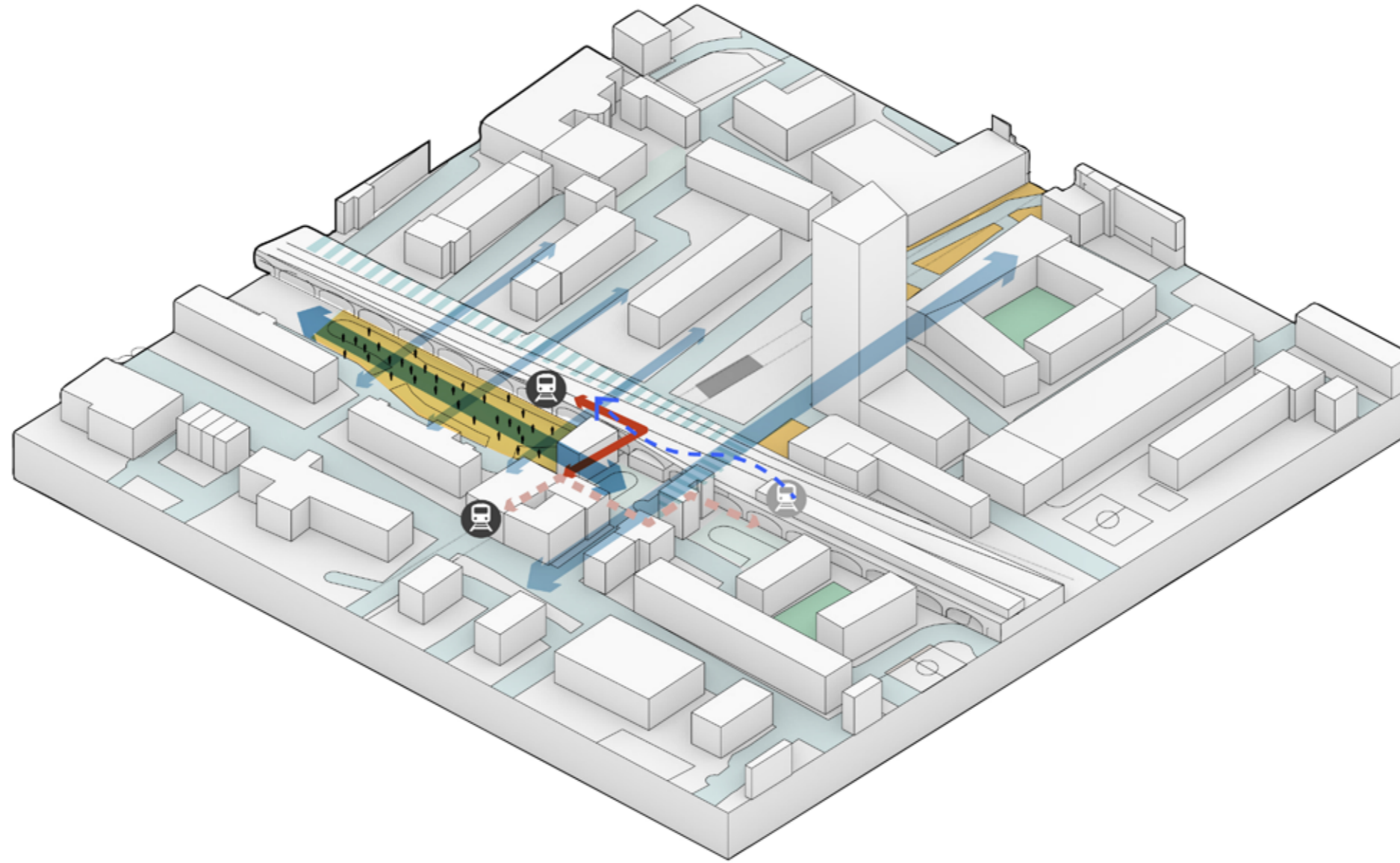

# Third Places



## Social Infrastructure

### Public Institutions

- Libraries
- Schools
- Playgrounds
- Parks
- Athletic Fields
- Swimming pools

### Space for Public realm

- Sidewalks
- Courtyards
- Community gardens
- green spaces

### Community organizations

- Churches
- Civic associations

### 'Third Space'

- Cafes
- Diners
- Barbershops
- bookstores

## Hard Infrastructure

### Transit Network

- System for private vehicles
- buses
- trains
- Levee

### Others

- Waterworks
- Waste treatment facilities
- Sewage Systems
- Fuel supply lines
- Electric grids

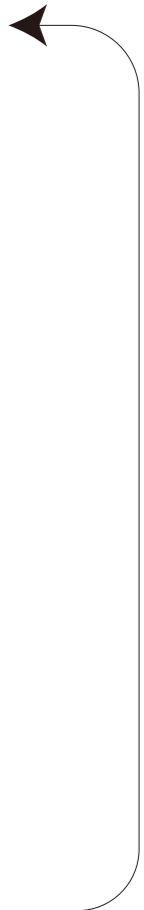

# Incubator

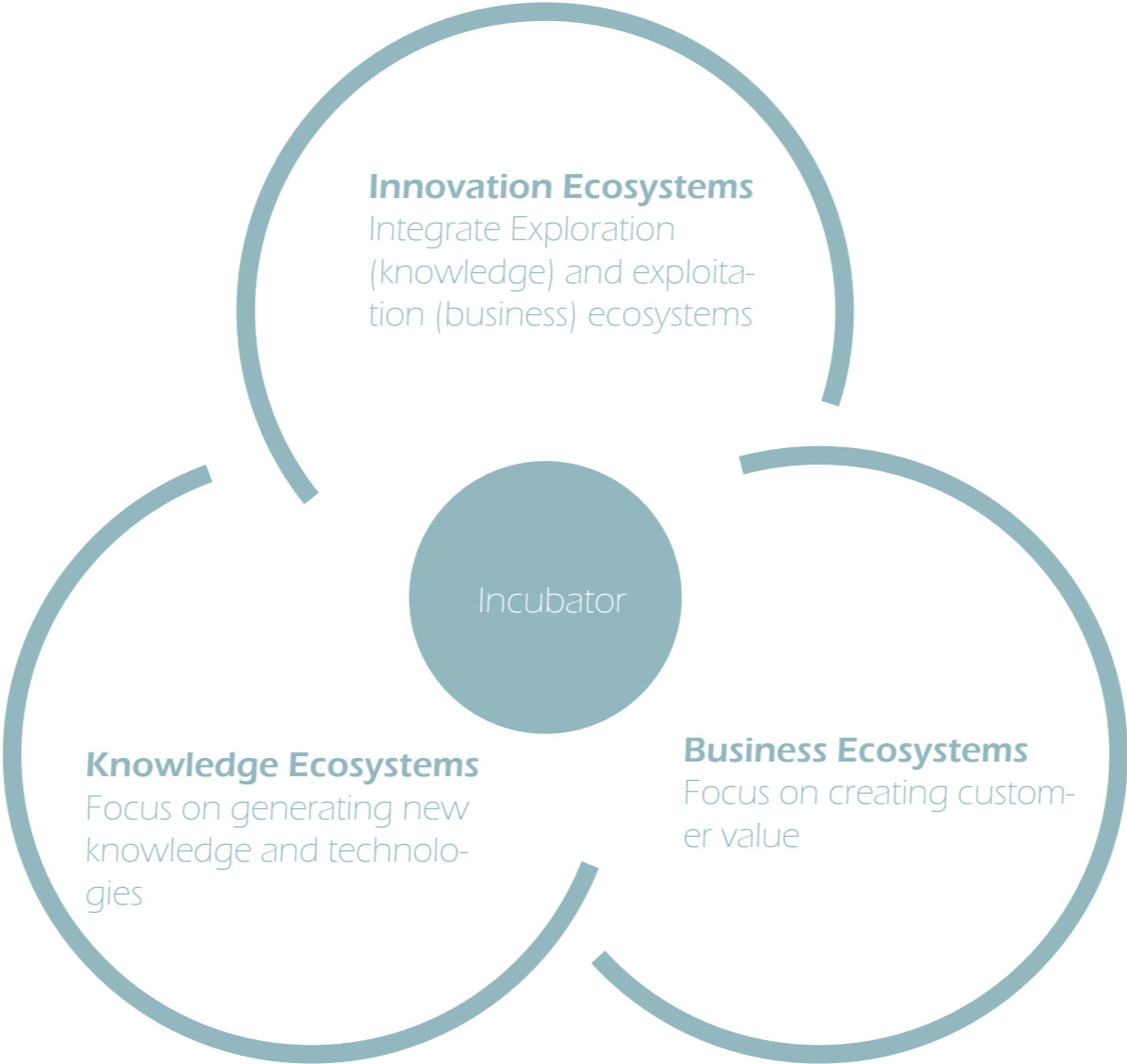

# Programmes

P5 PRESENTATION

ADC 2022/2023

23

June 30th, 2023

5504295

Deying Chen

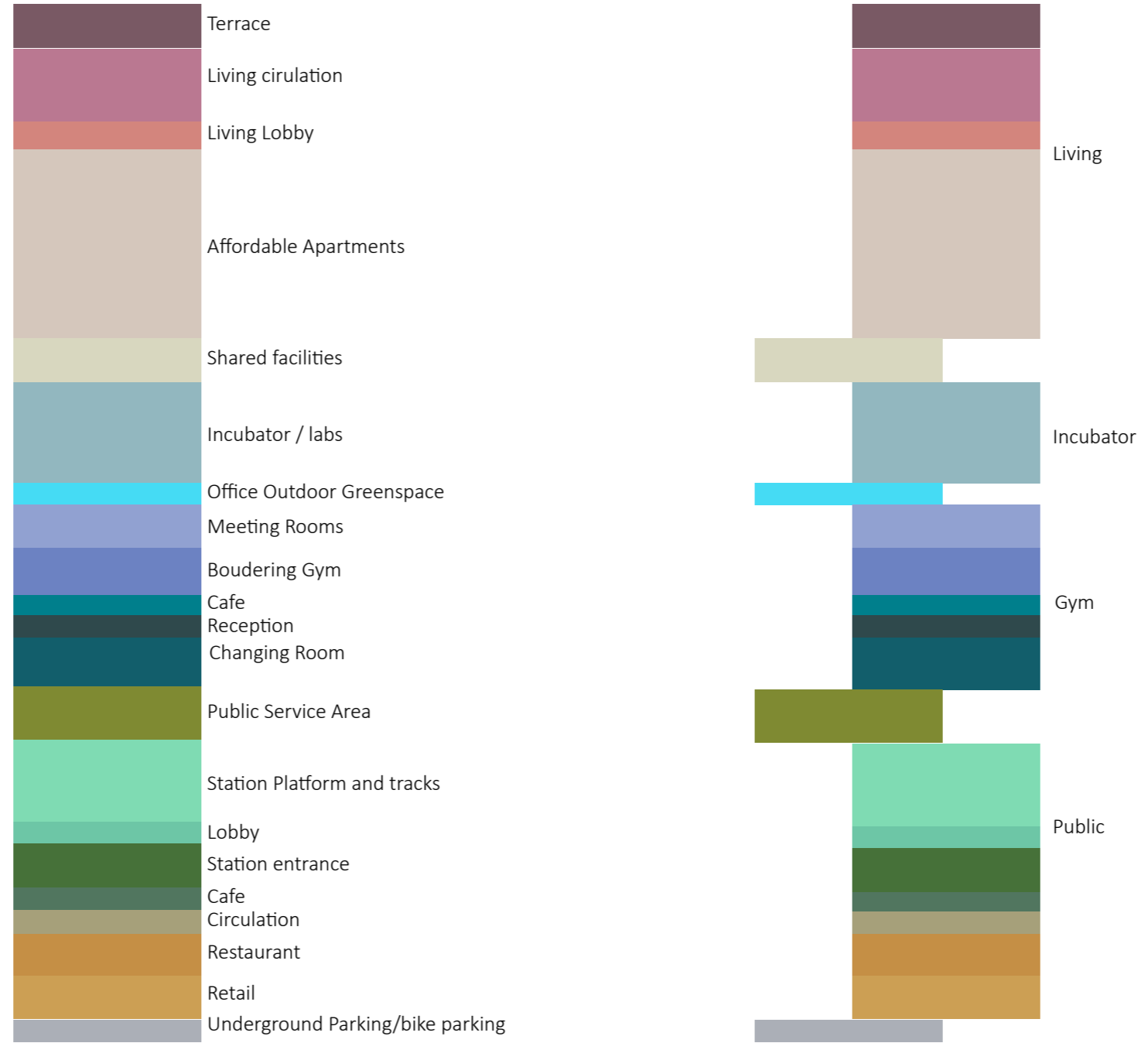

# 2. Visibility

P5 PRESENTATION  
ADC 2022/2023  
June 30th, 2023  
5504295  
Deying Chen

24

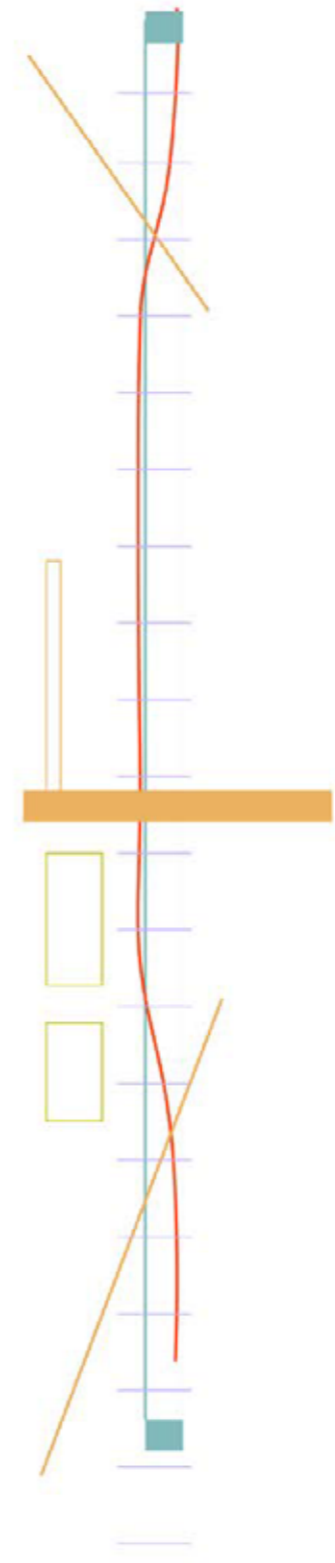
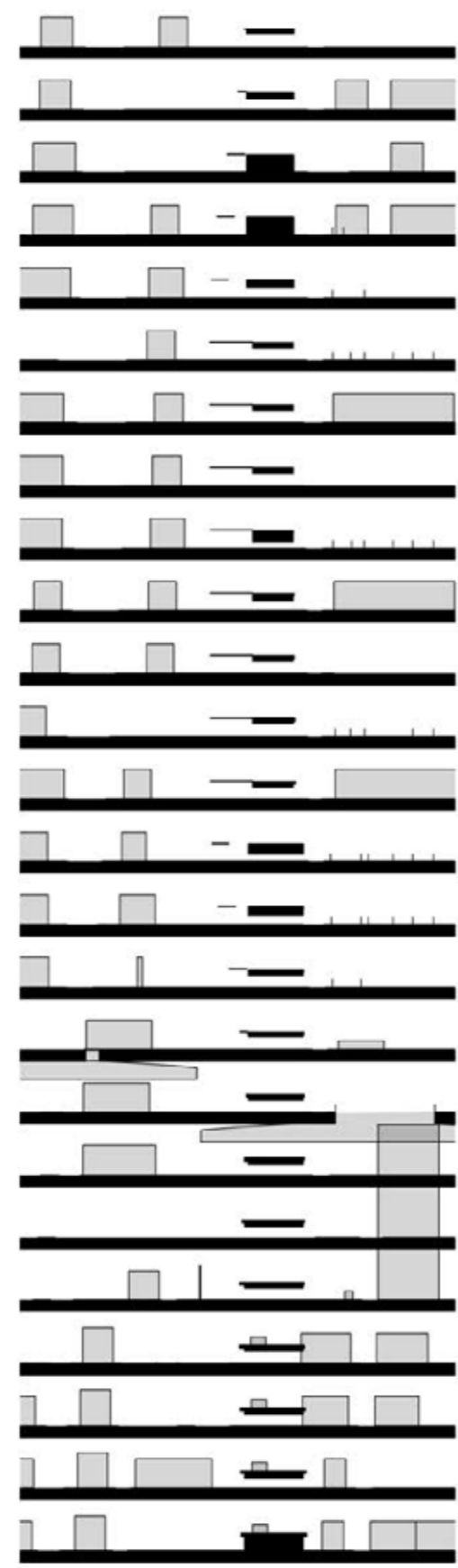



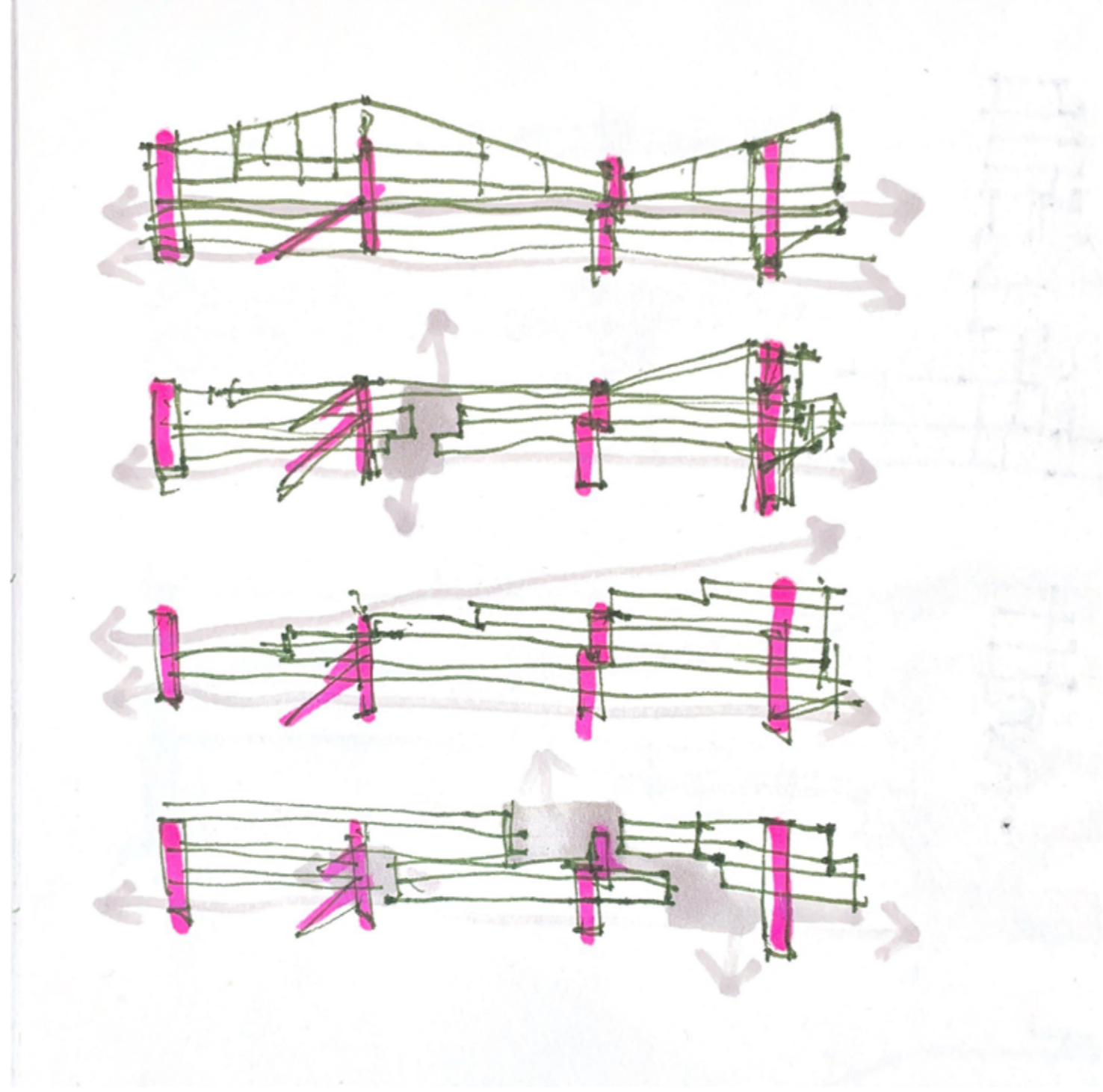

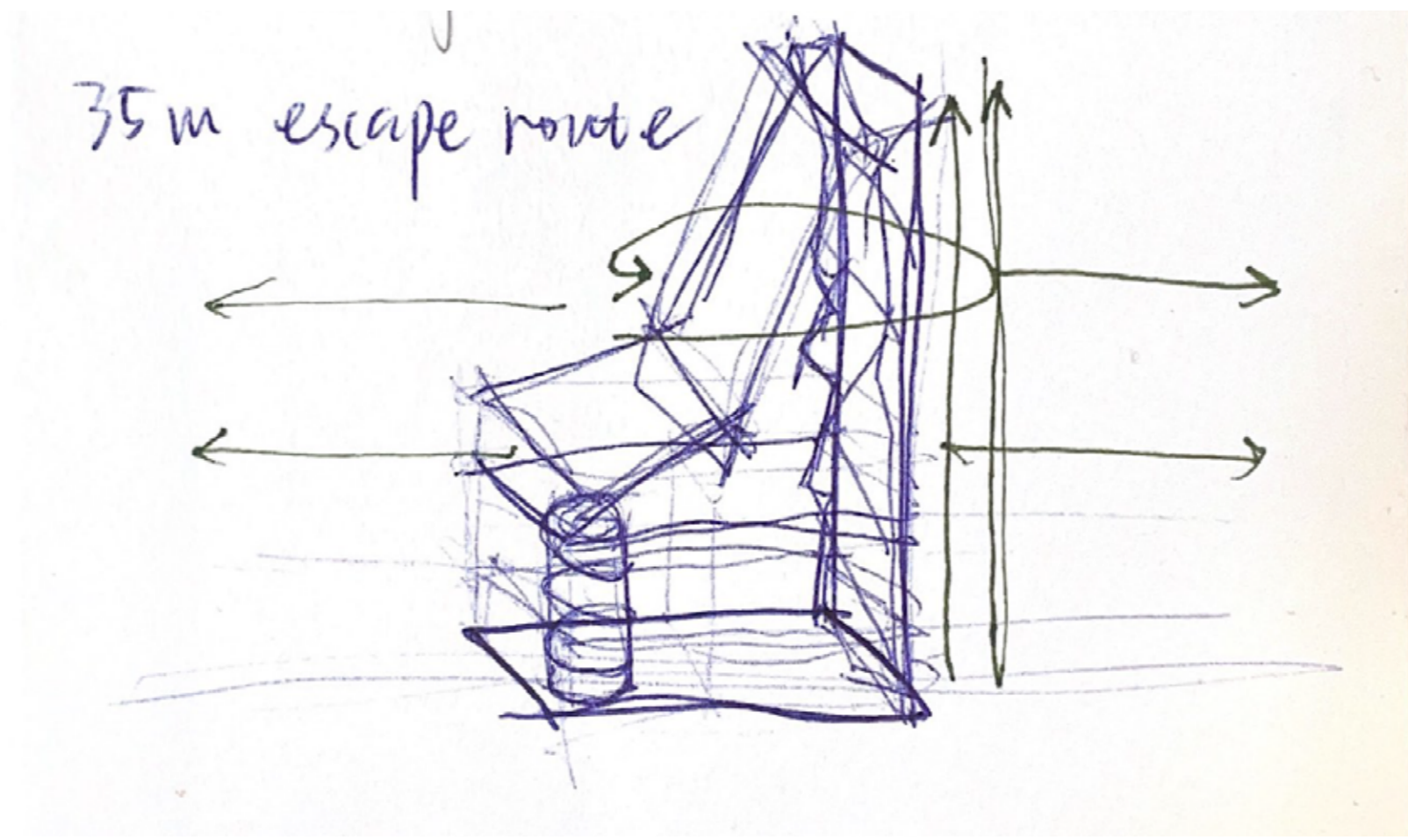



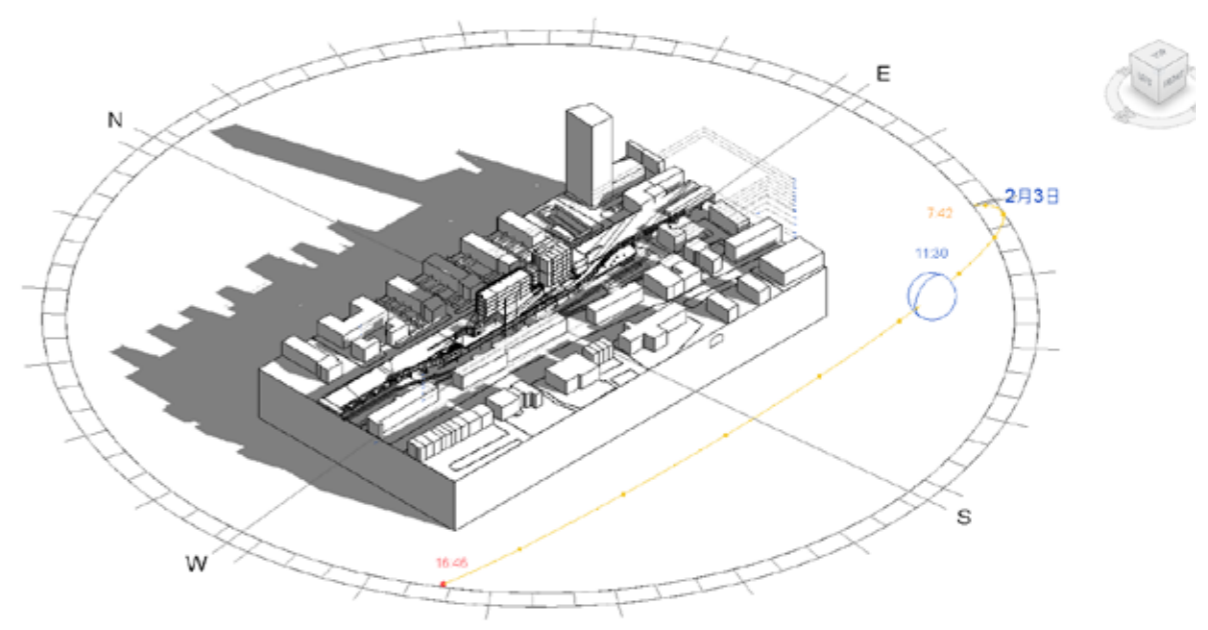
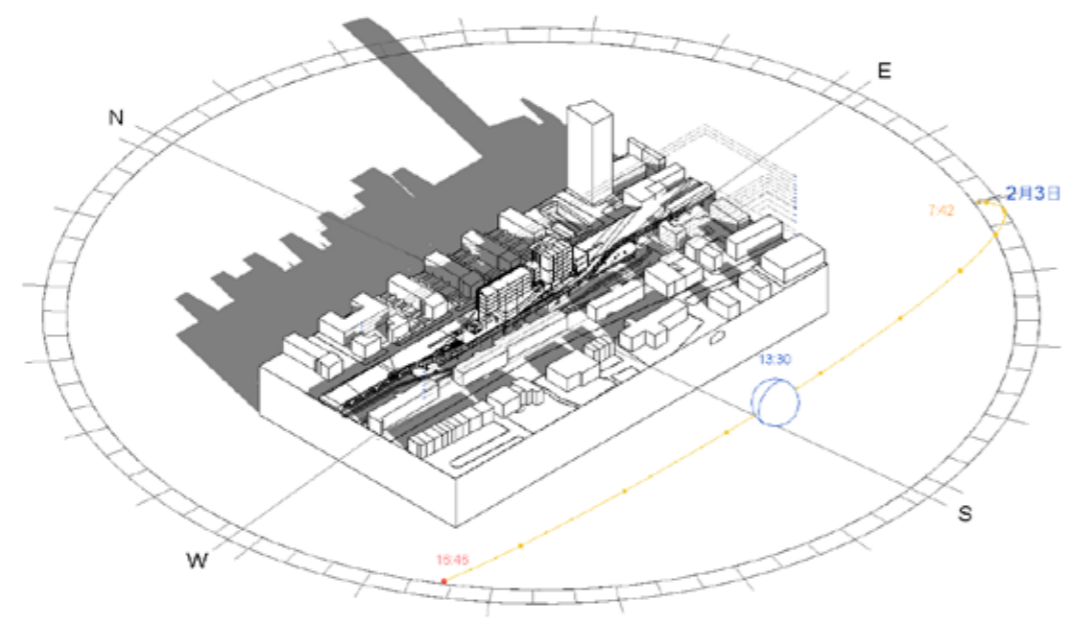
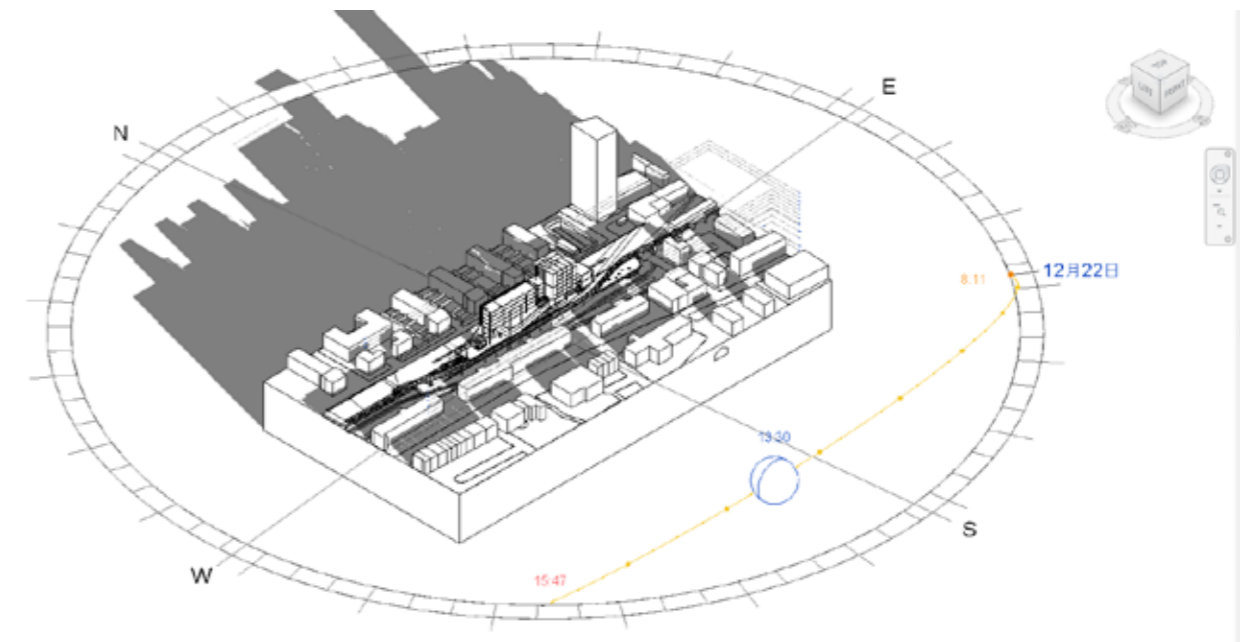
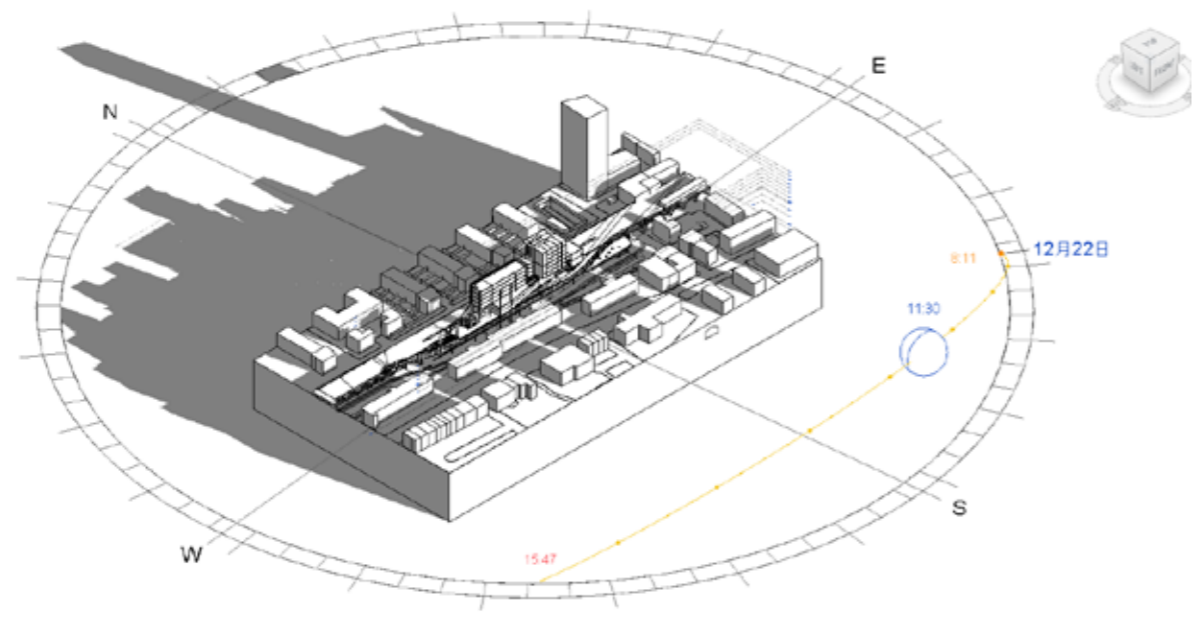



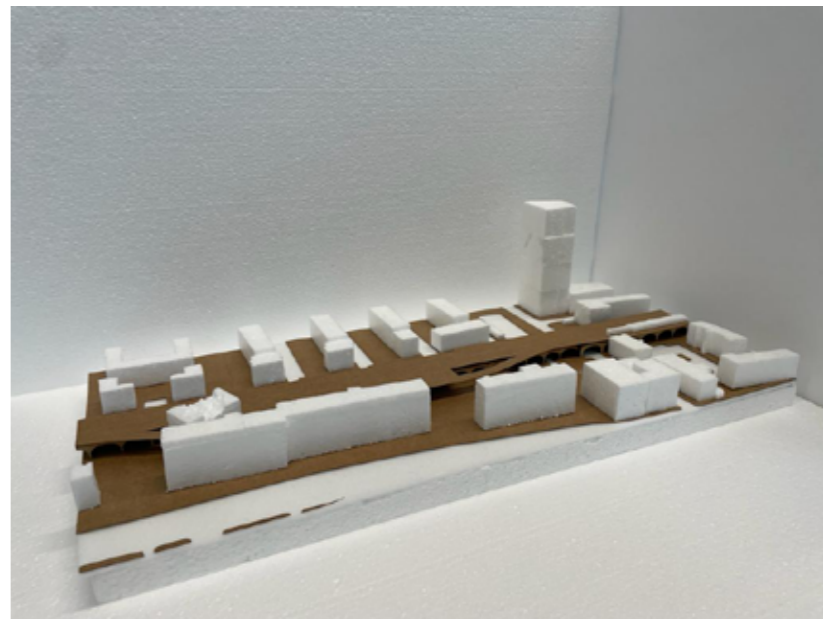
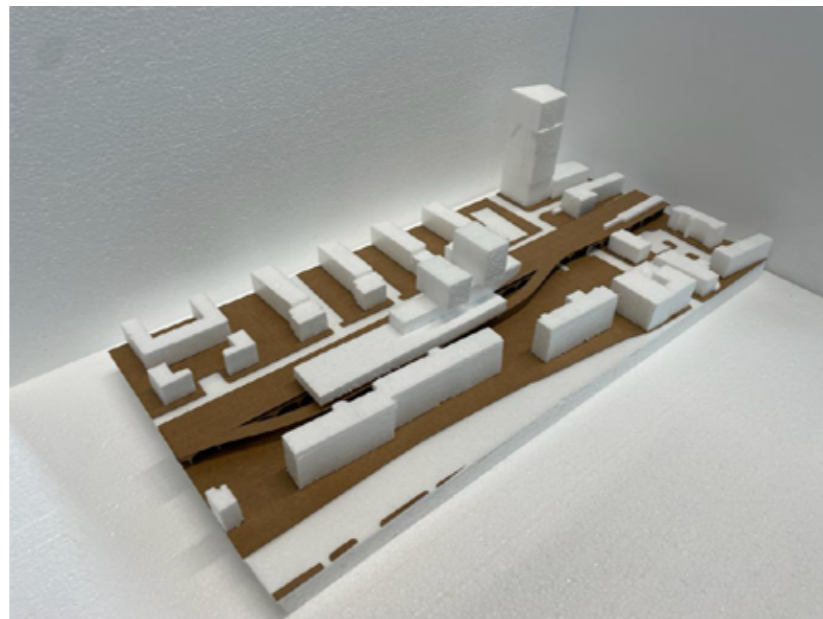
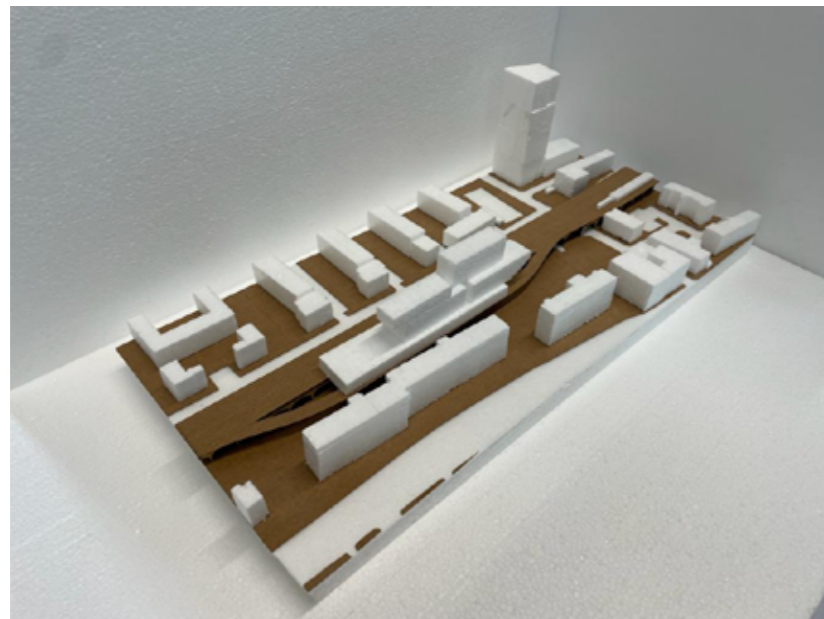
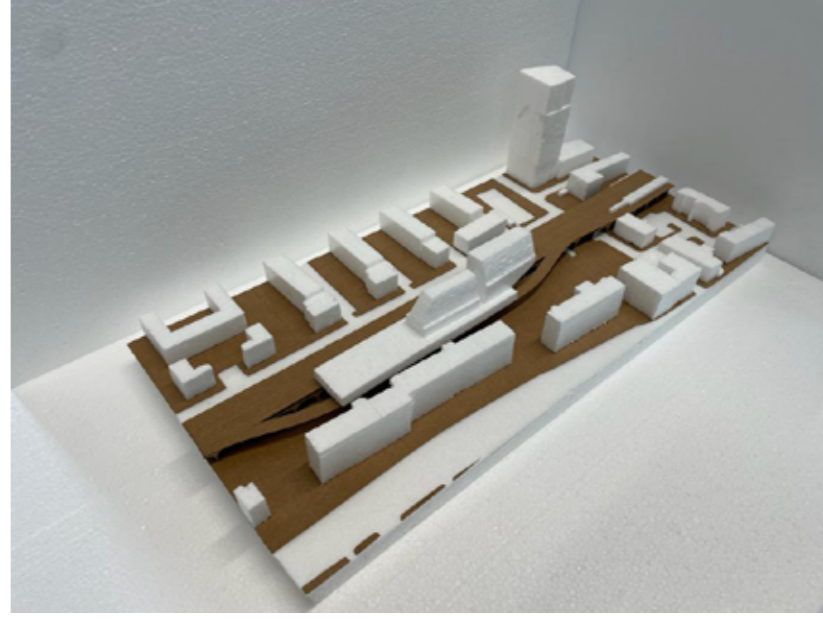
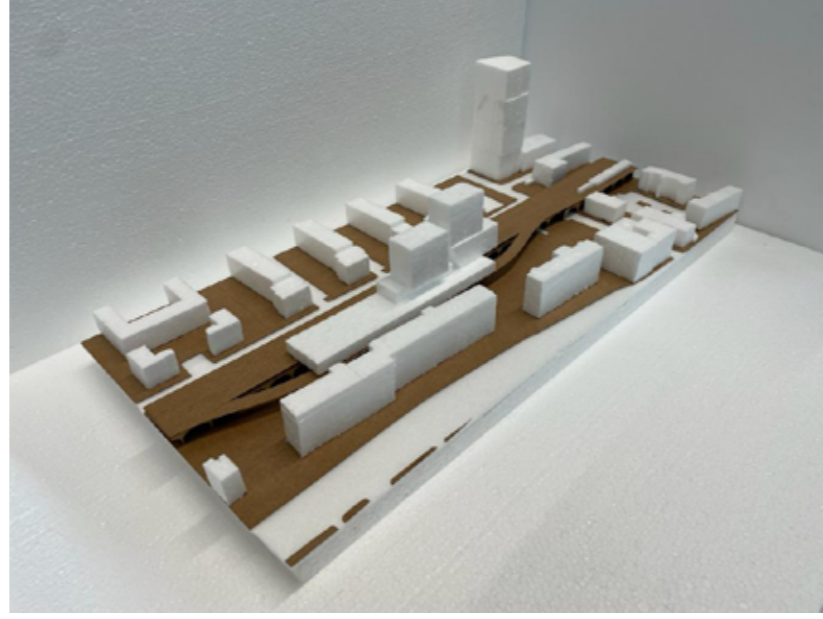
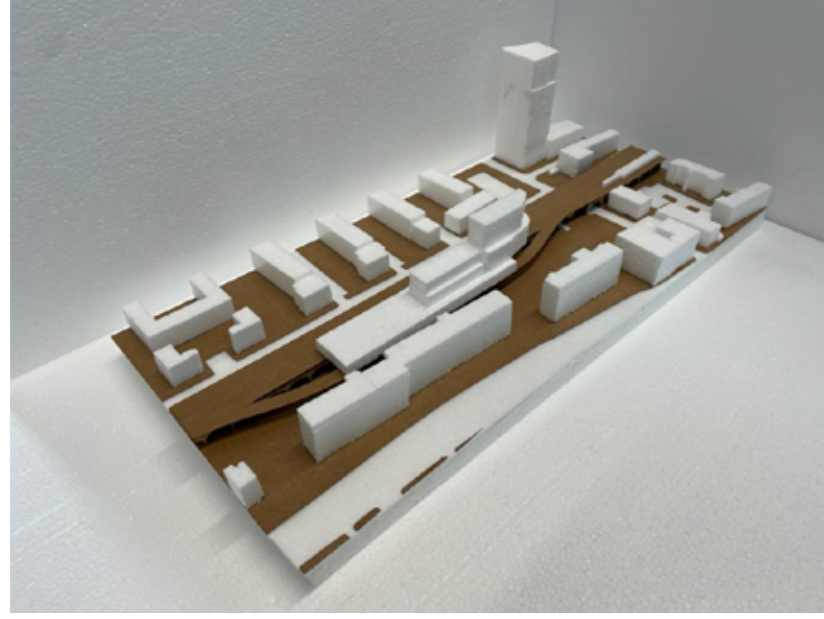
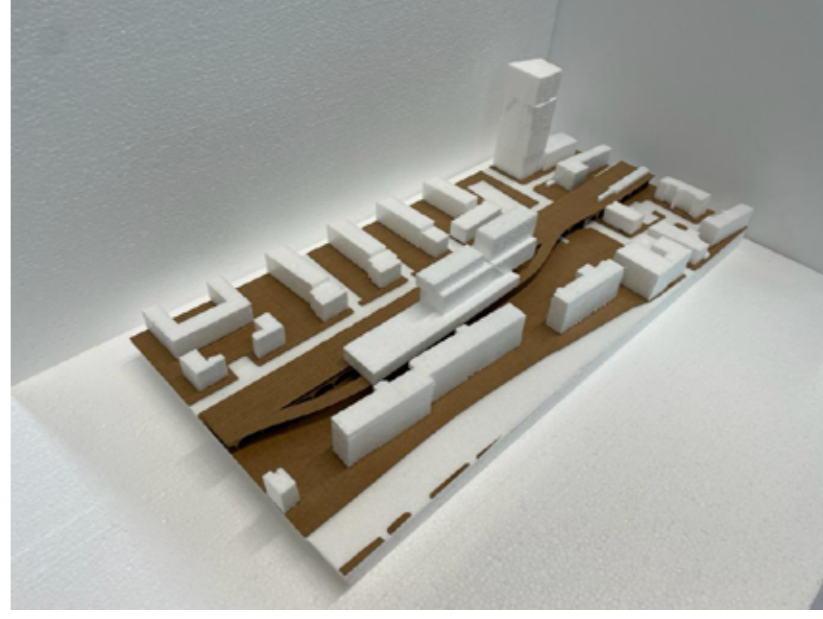
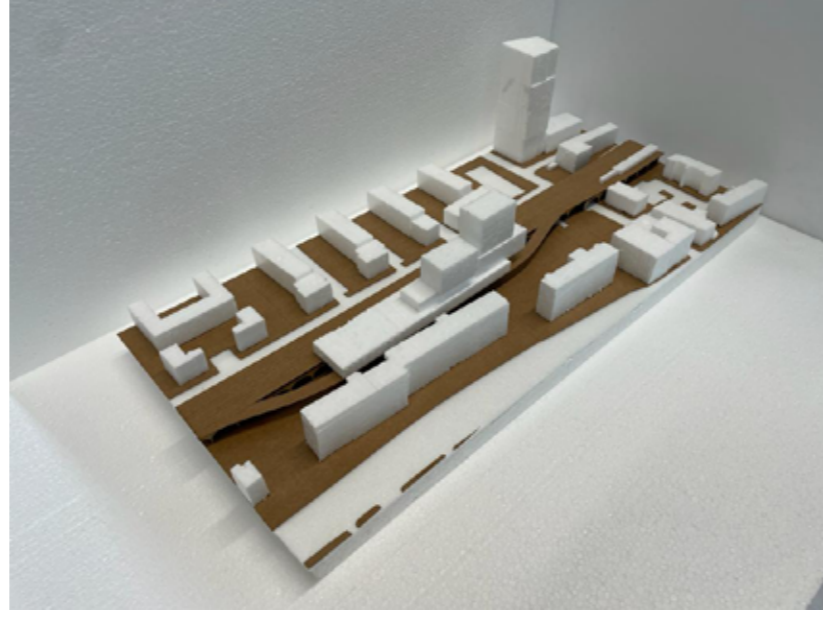
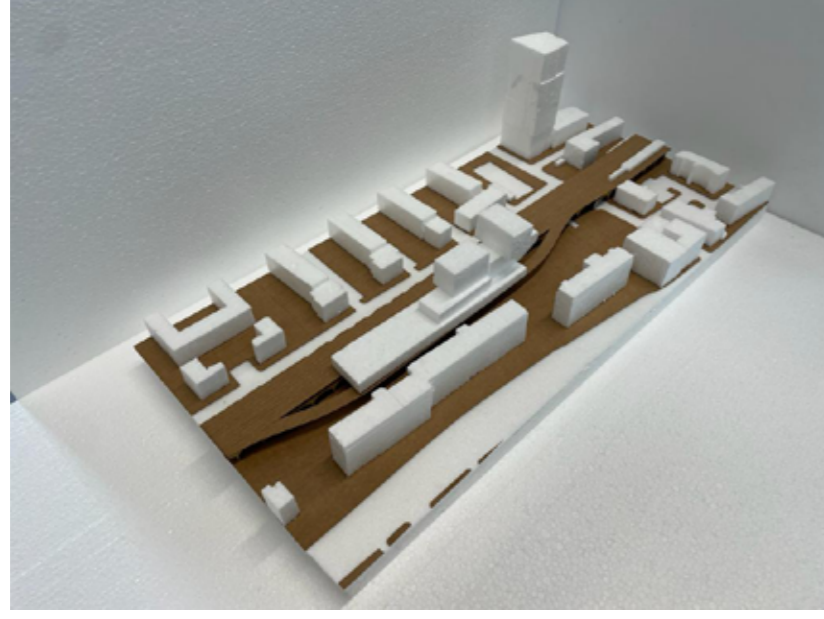



# Reference - Material





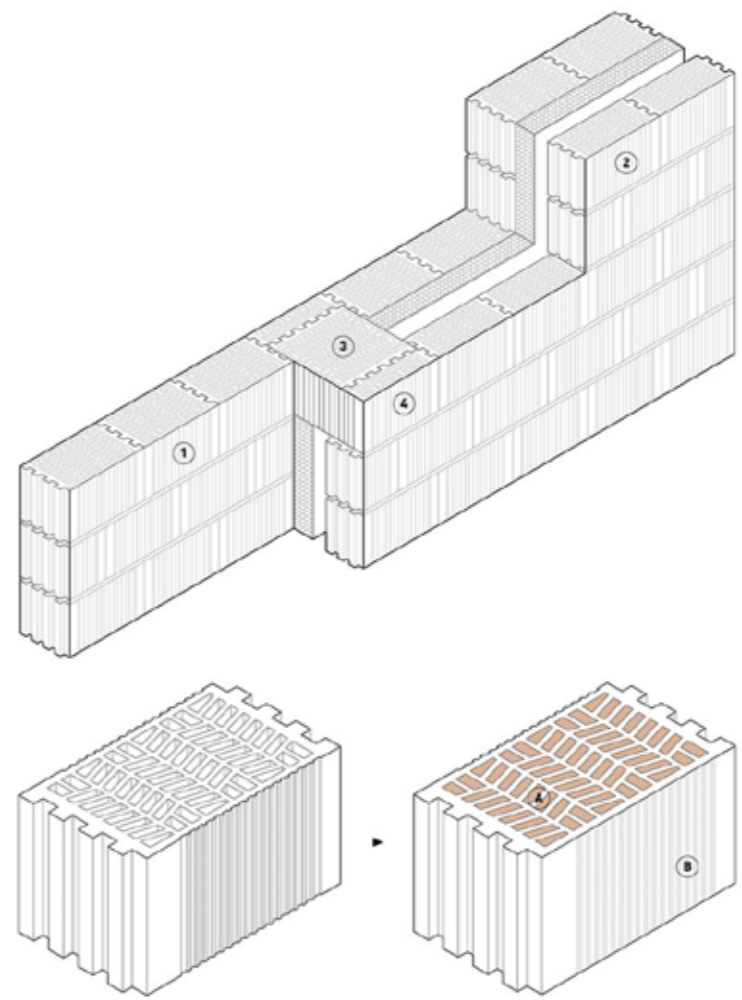

**FACADE DETAIL**

1 interior structural leaf of 19cm thermo-clay | 2 exterior leaf of 14cm thermo-clay | 3 29cm thermo-clay block to join both leaves | 4 half a block of 14cm thermo-clay  
 A thermo-clay block filled with excavation soils to increase its thermal inertia | B thermo-clay block plastered with lime mortar for the chamber waterproofing

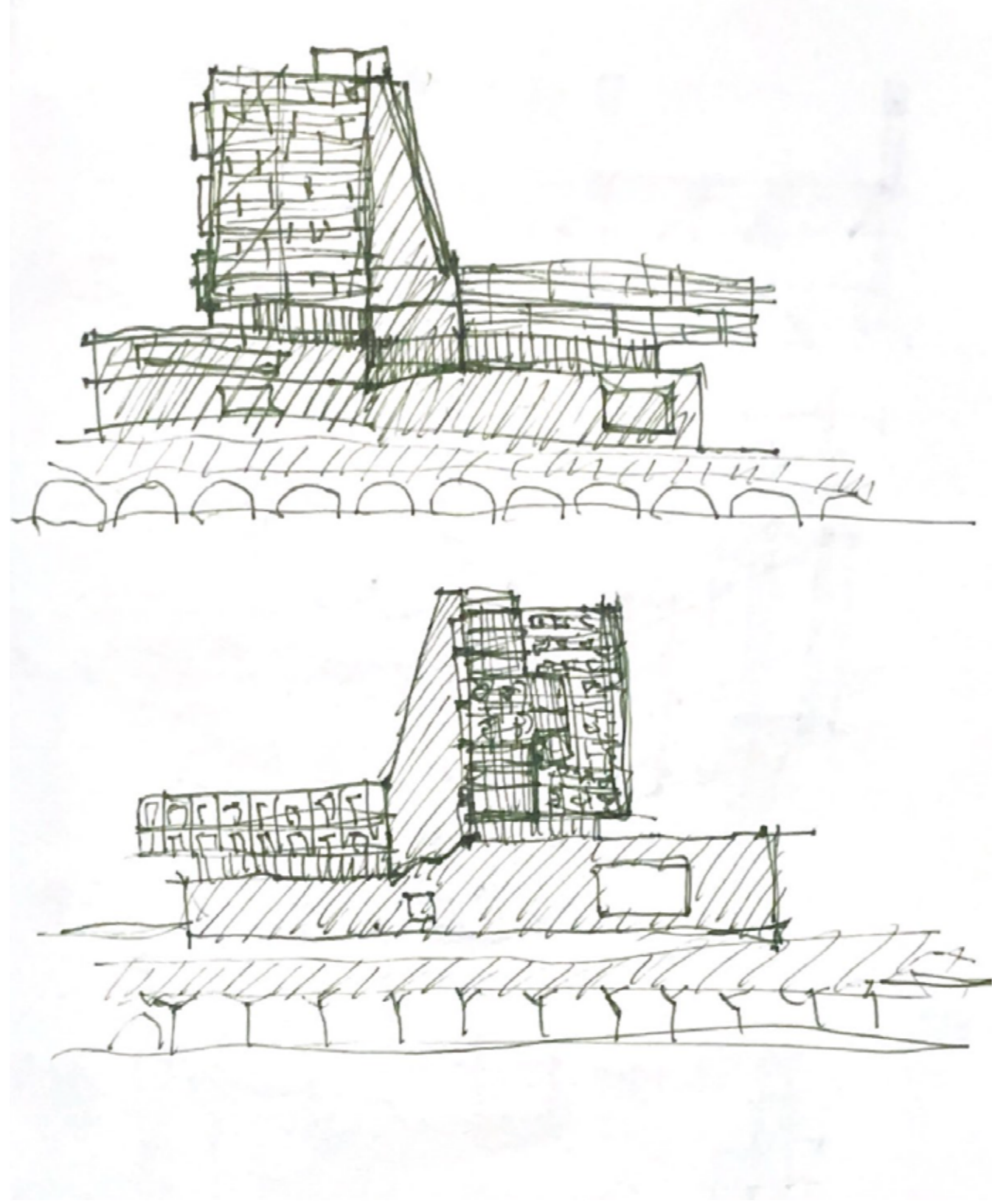



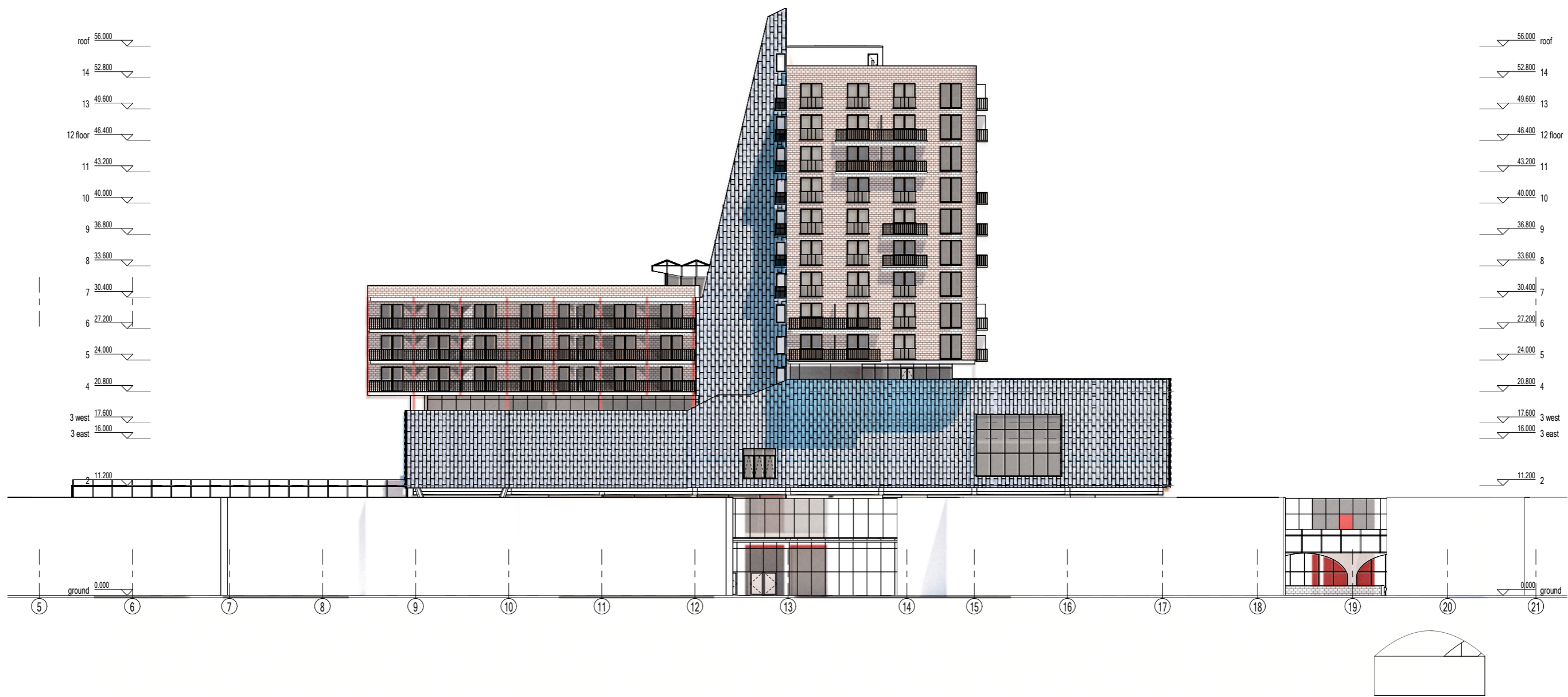

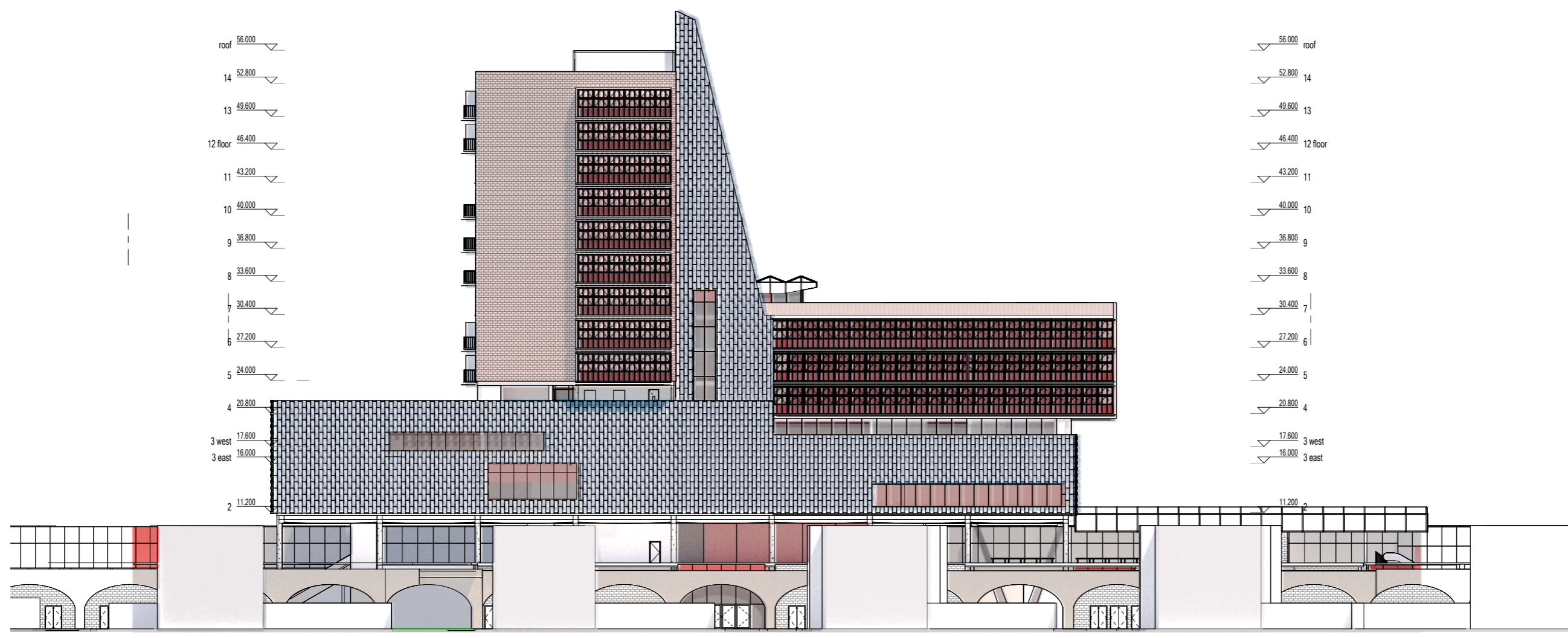



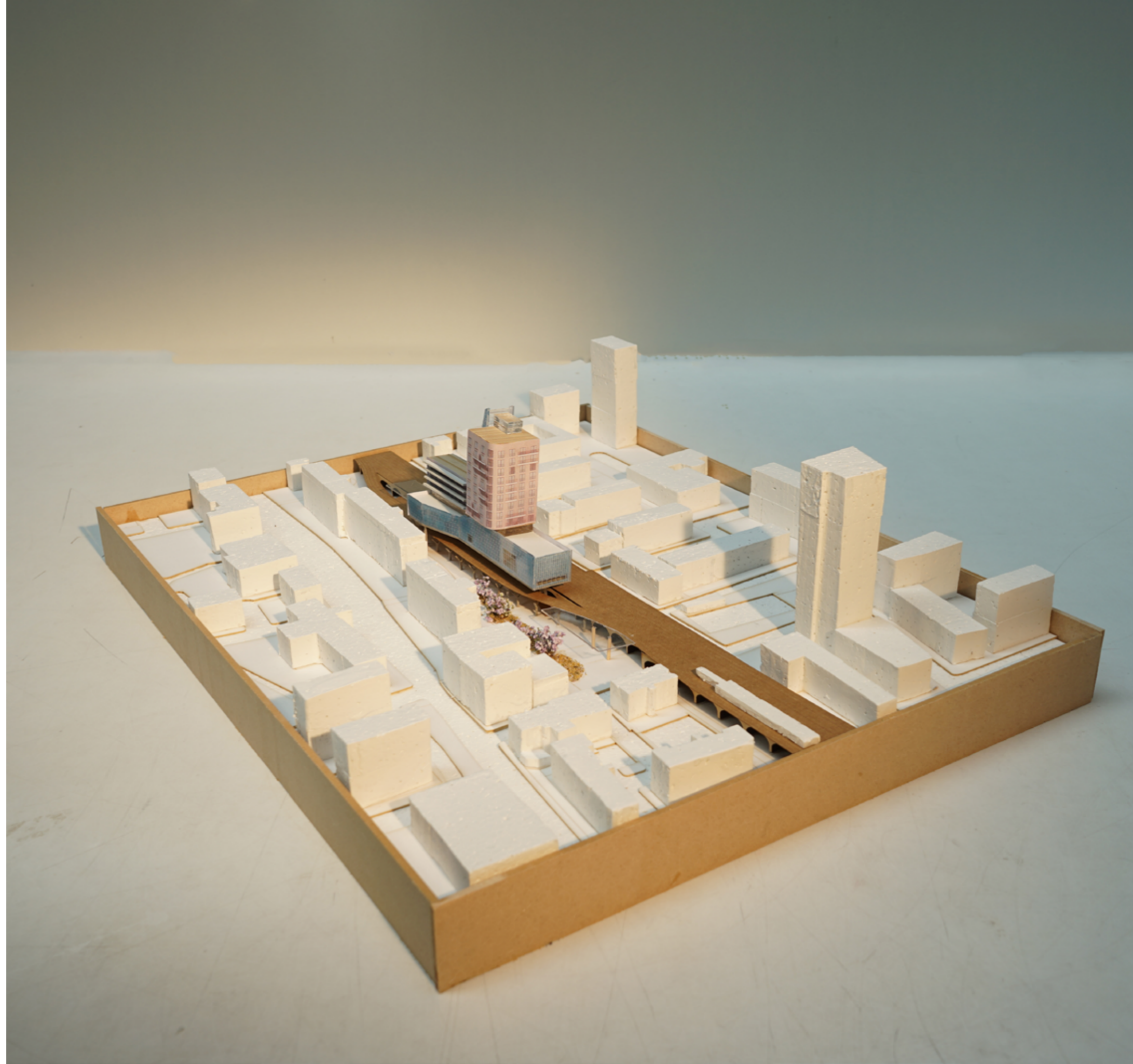



# 3. Eyes on the street

35



Image Landsat / Copernicus









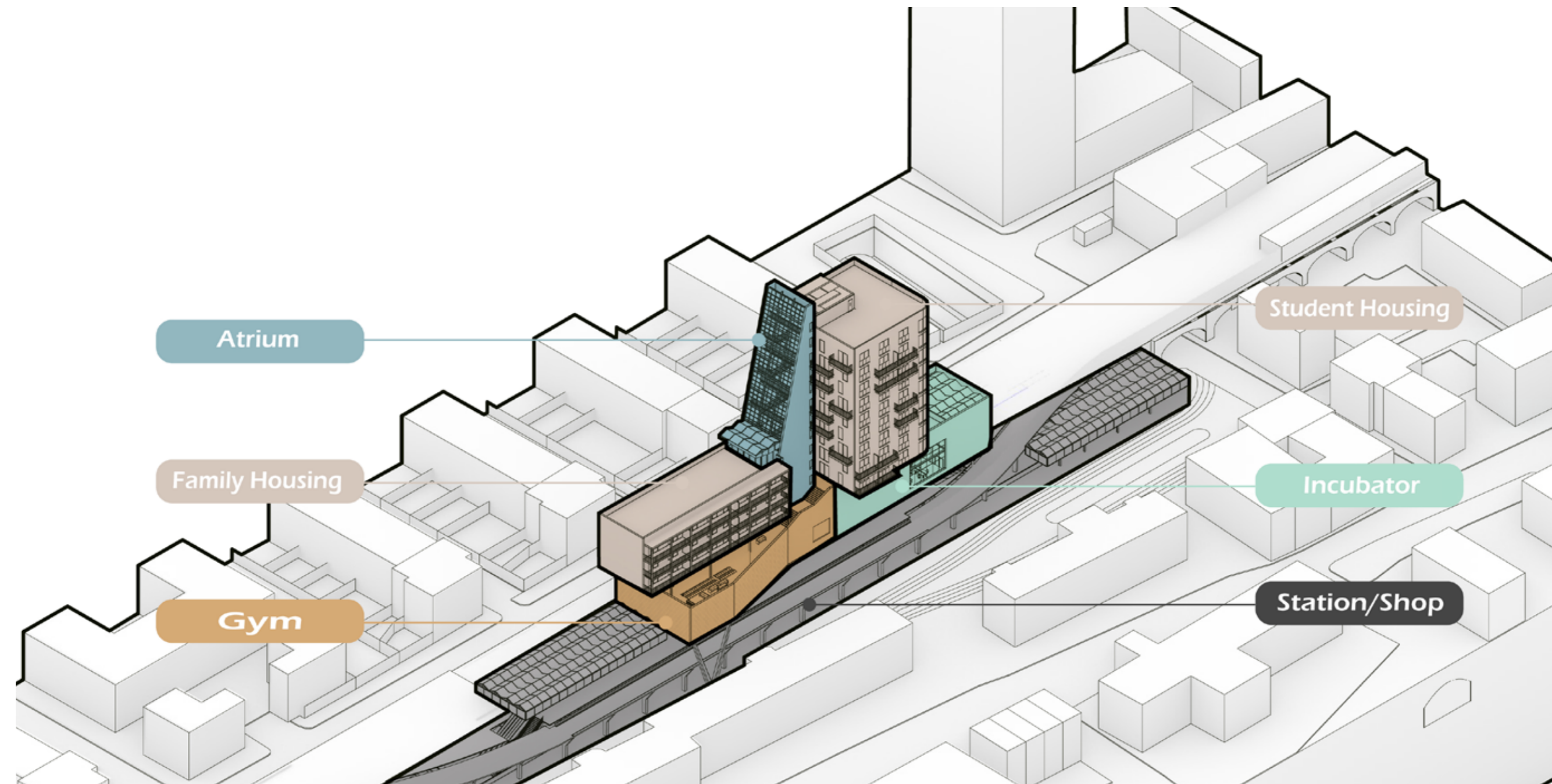

Atrium

Family Housing

Gym

Student Housing

Incubator

Station/Shop



# Circulation

39

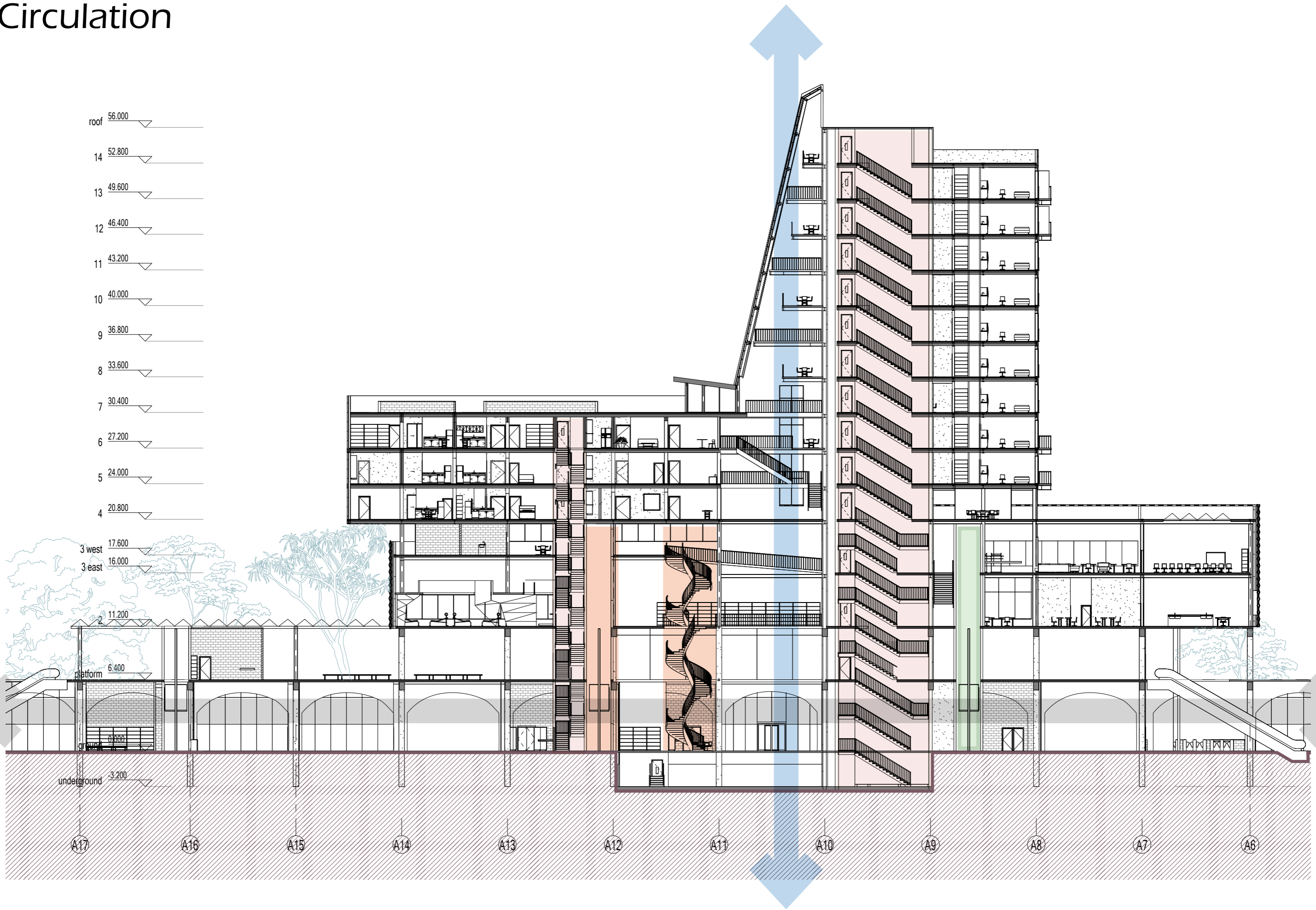

# Short Section

40

Living

Incubator

Public

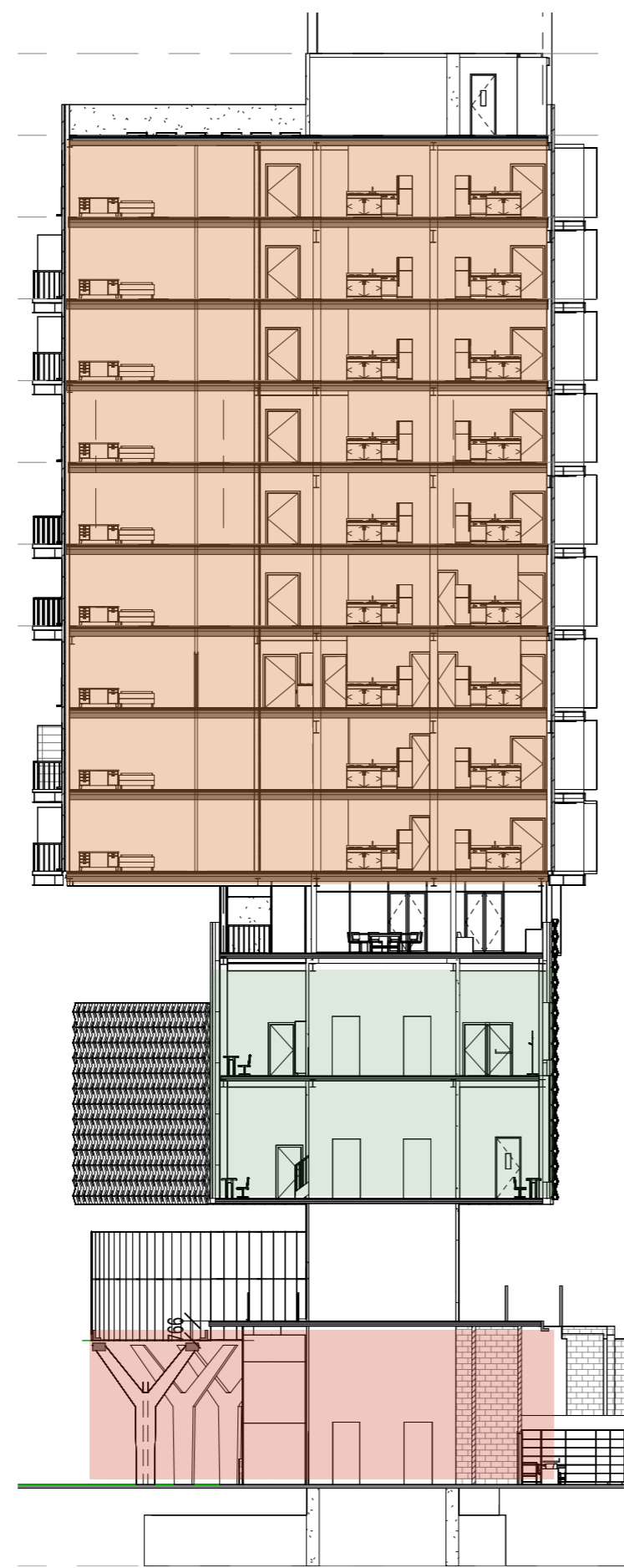

Living

Gym

Public

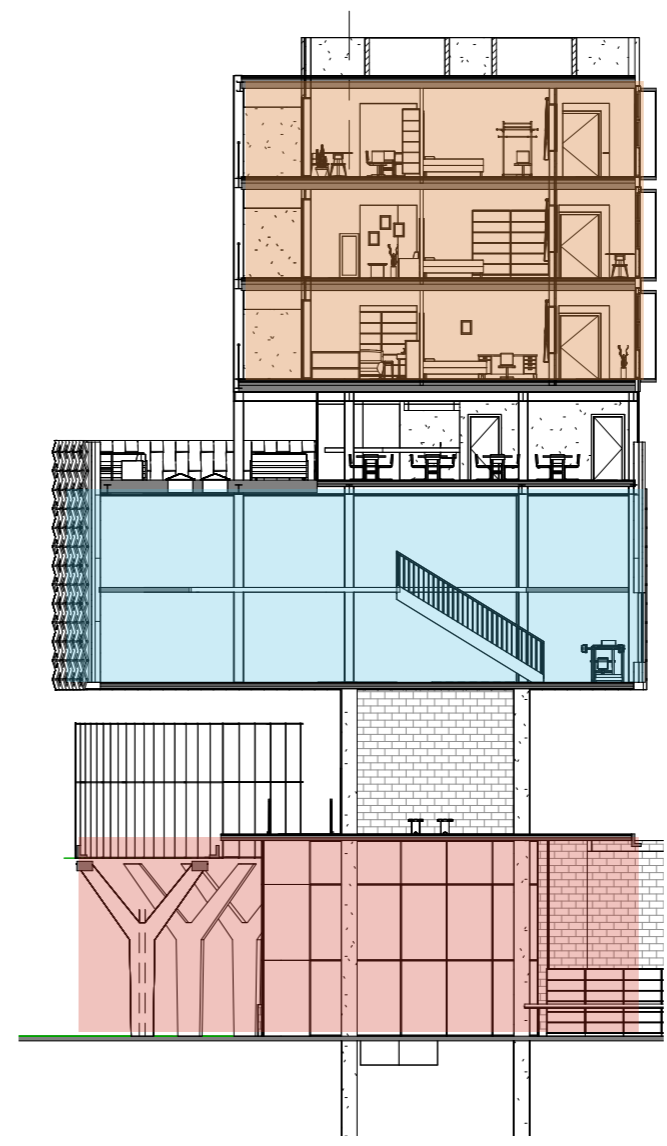



# Design Strategy: Porosity

## Different gradients of Openness

41

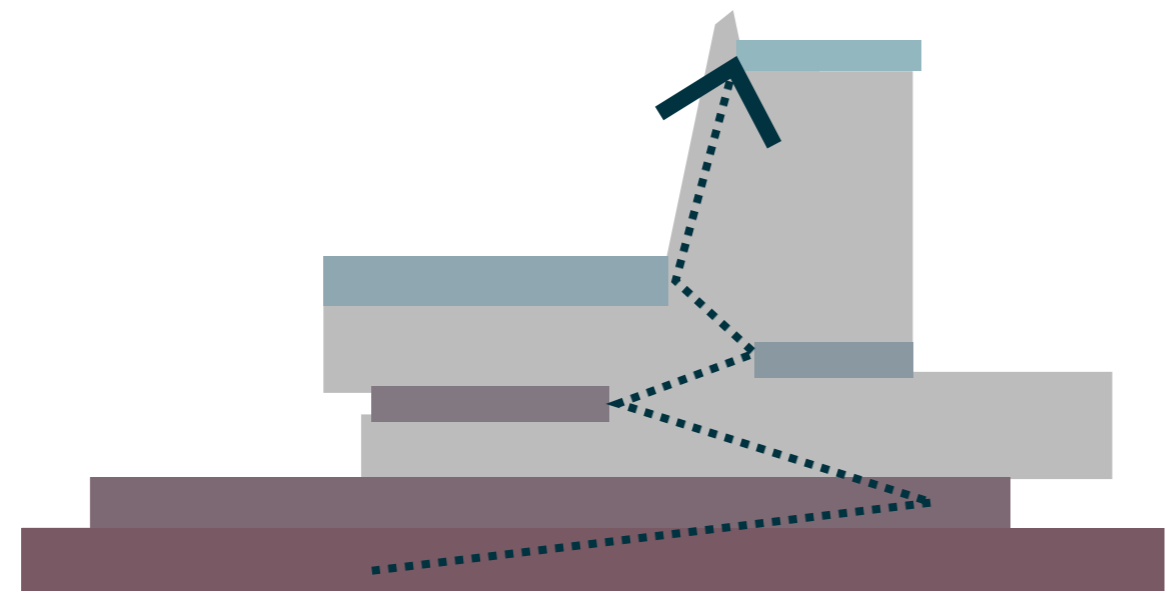

1, Public and Outdoor Spaces

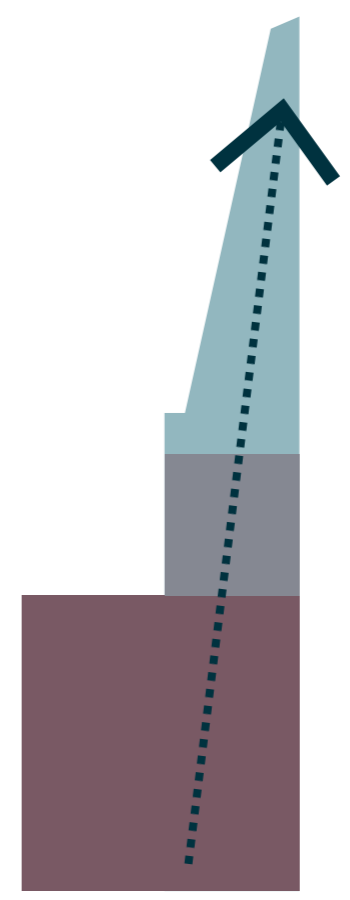

2, Vertical Atrium

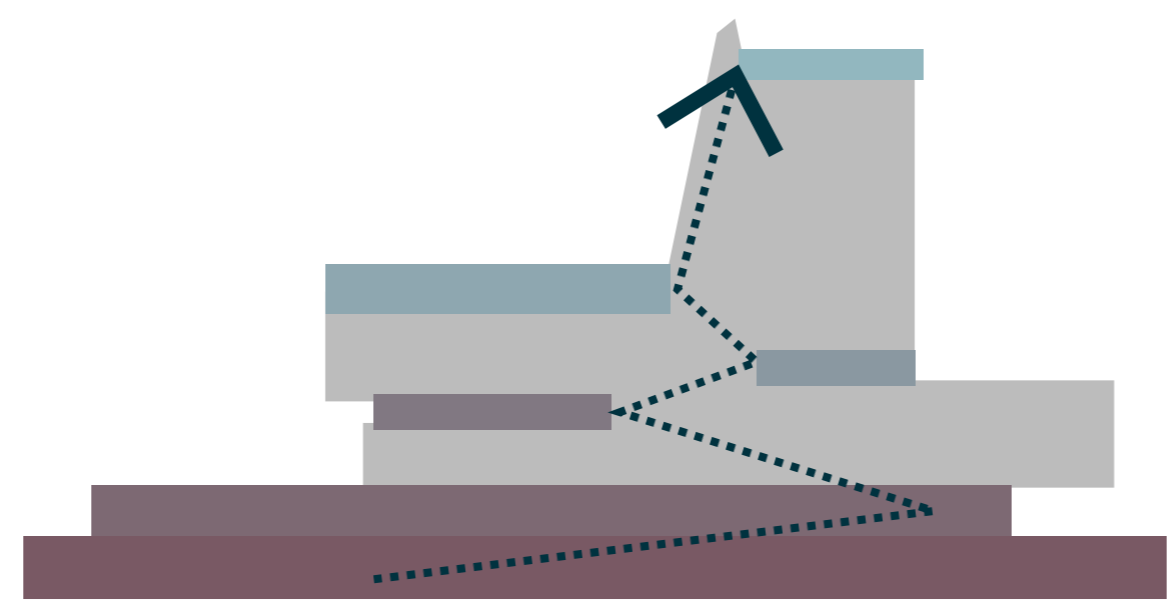

1, Public and Outdoor Spaces



# 1, Public and Outdoor Spaces

43

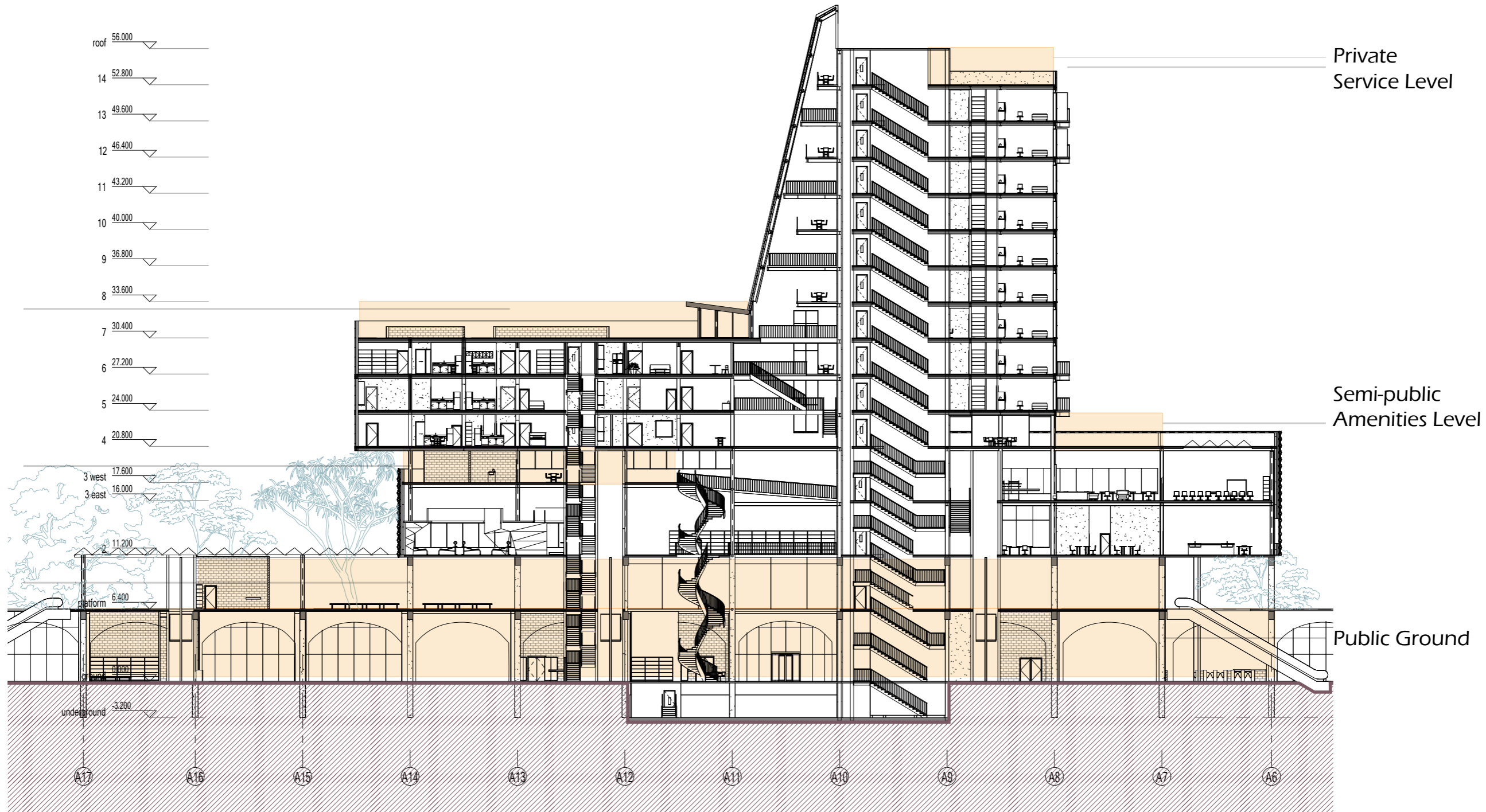

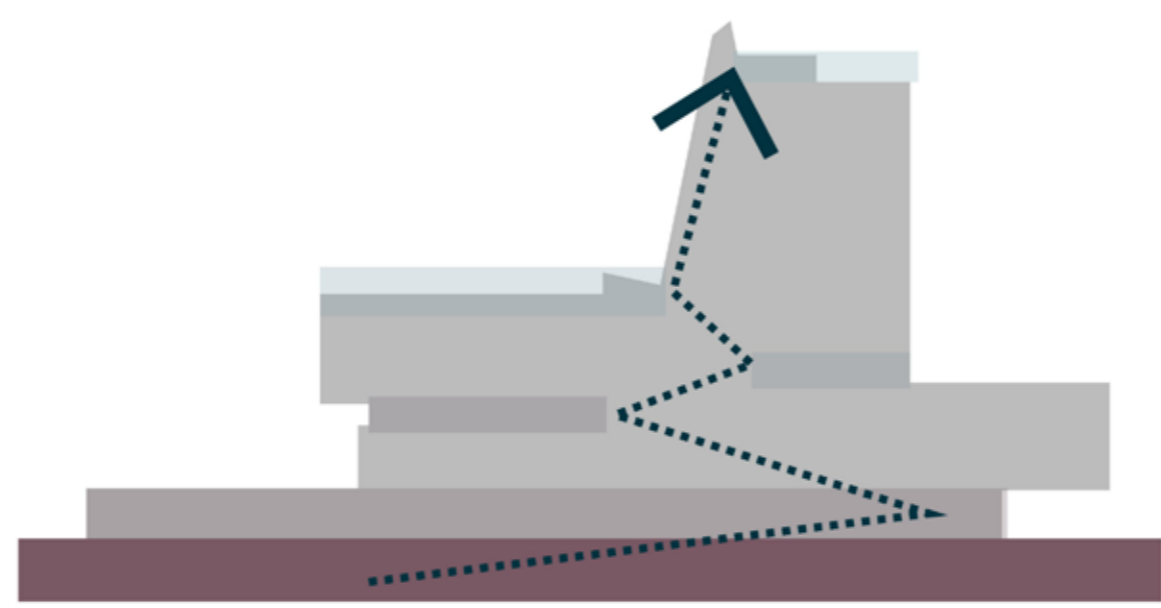

# 1. Public Ground



# 1, Public Ground

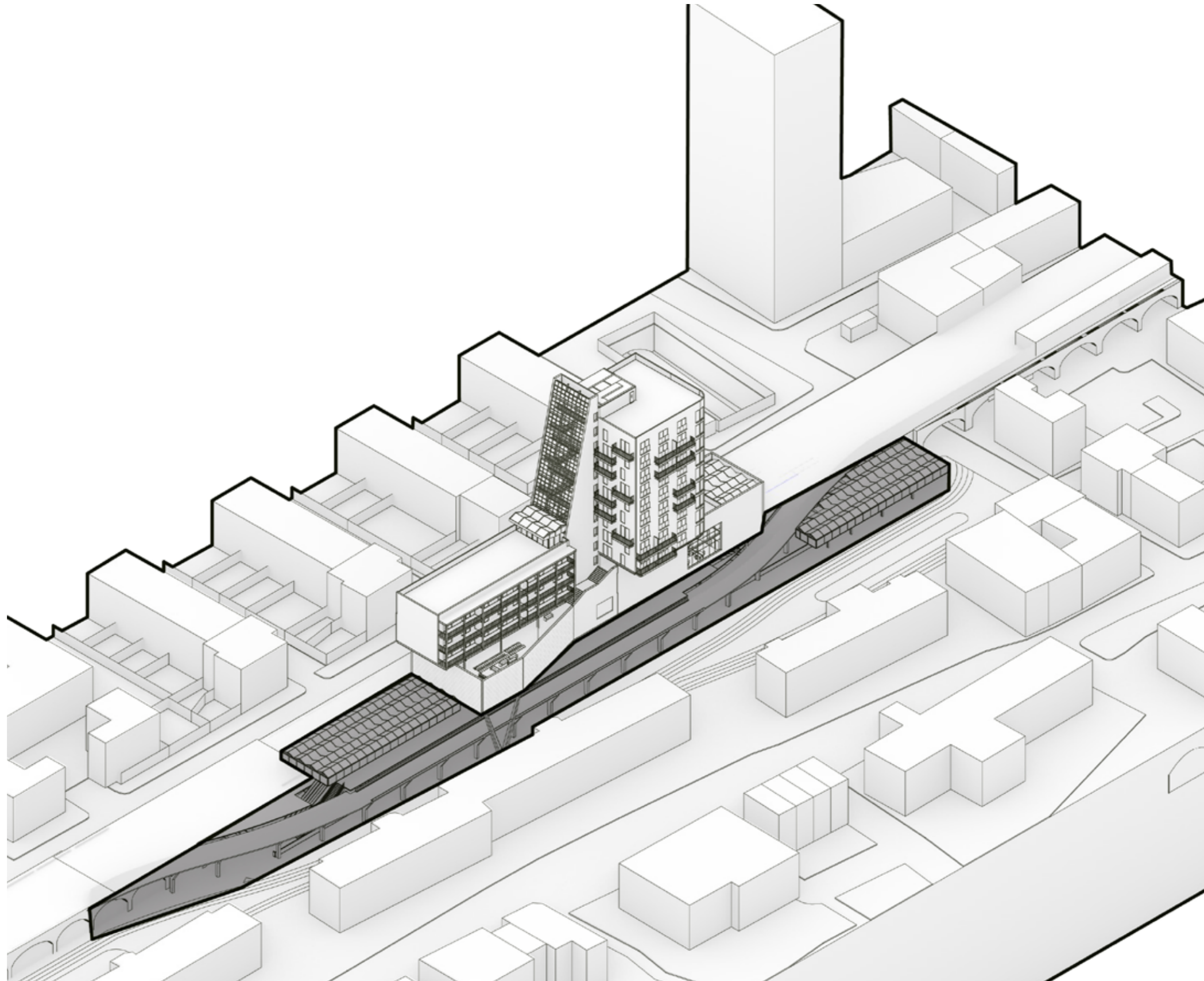

# Ground Floor plan

46

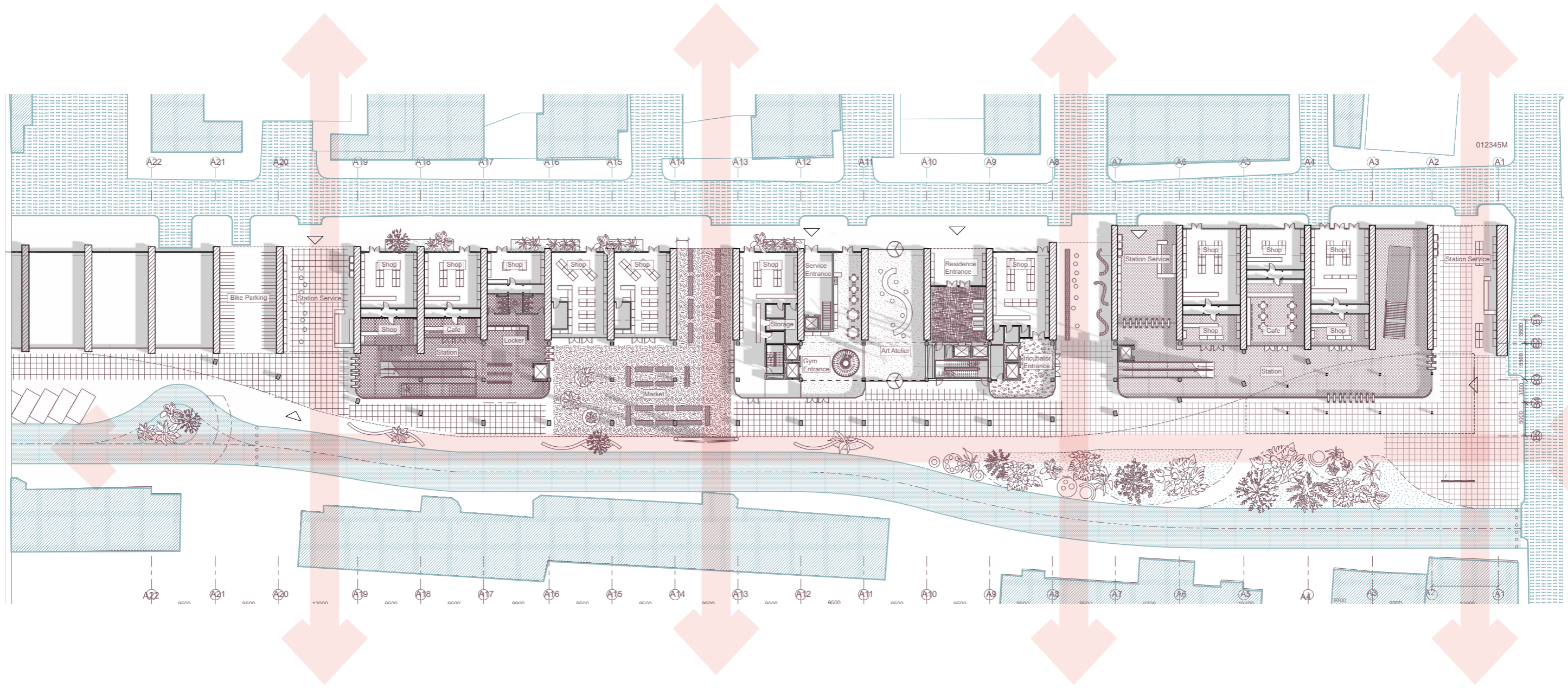

012345M



# Station

47

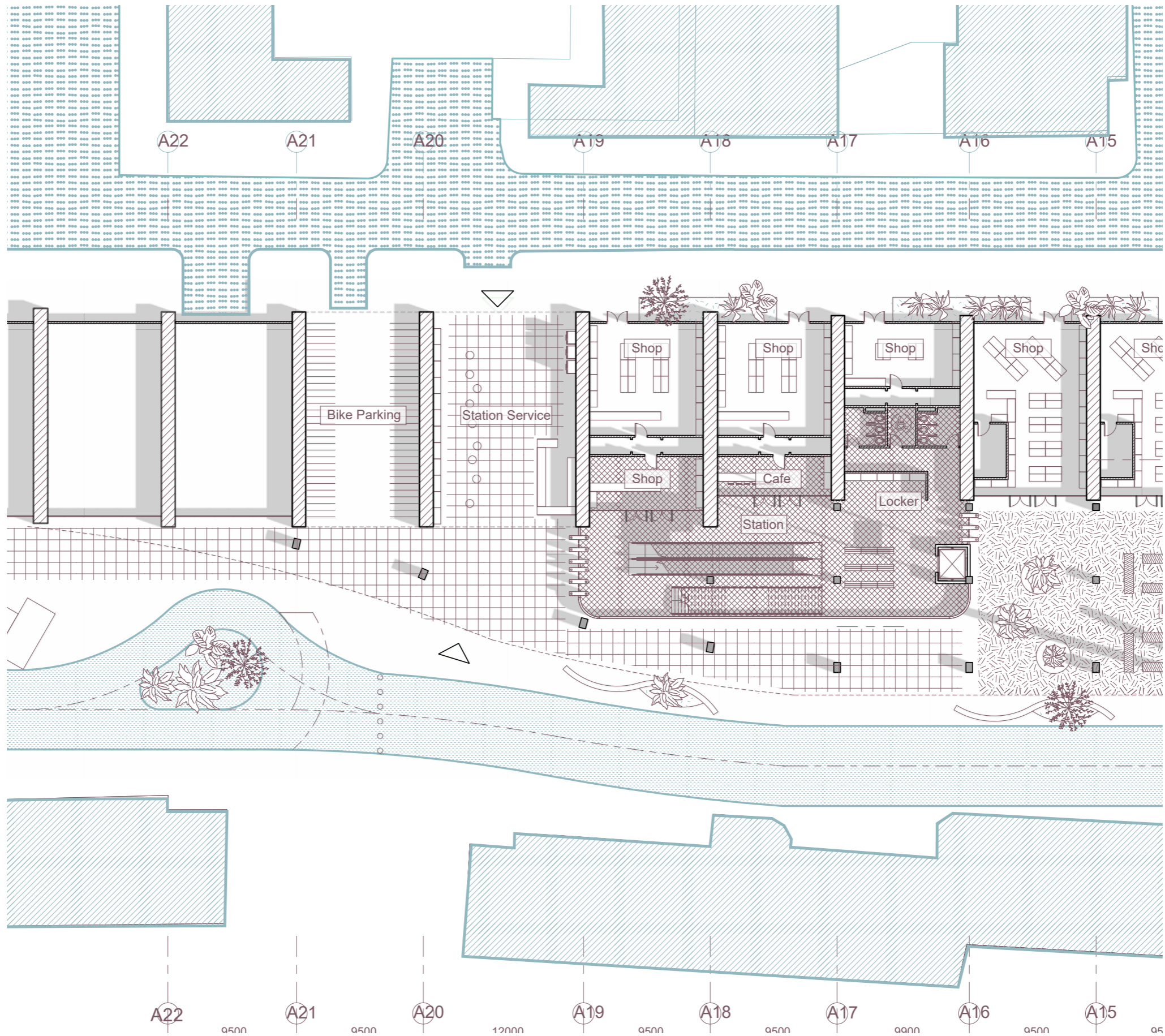

# Station

48

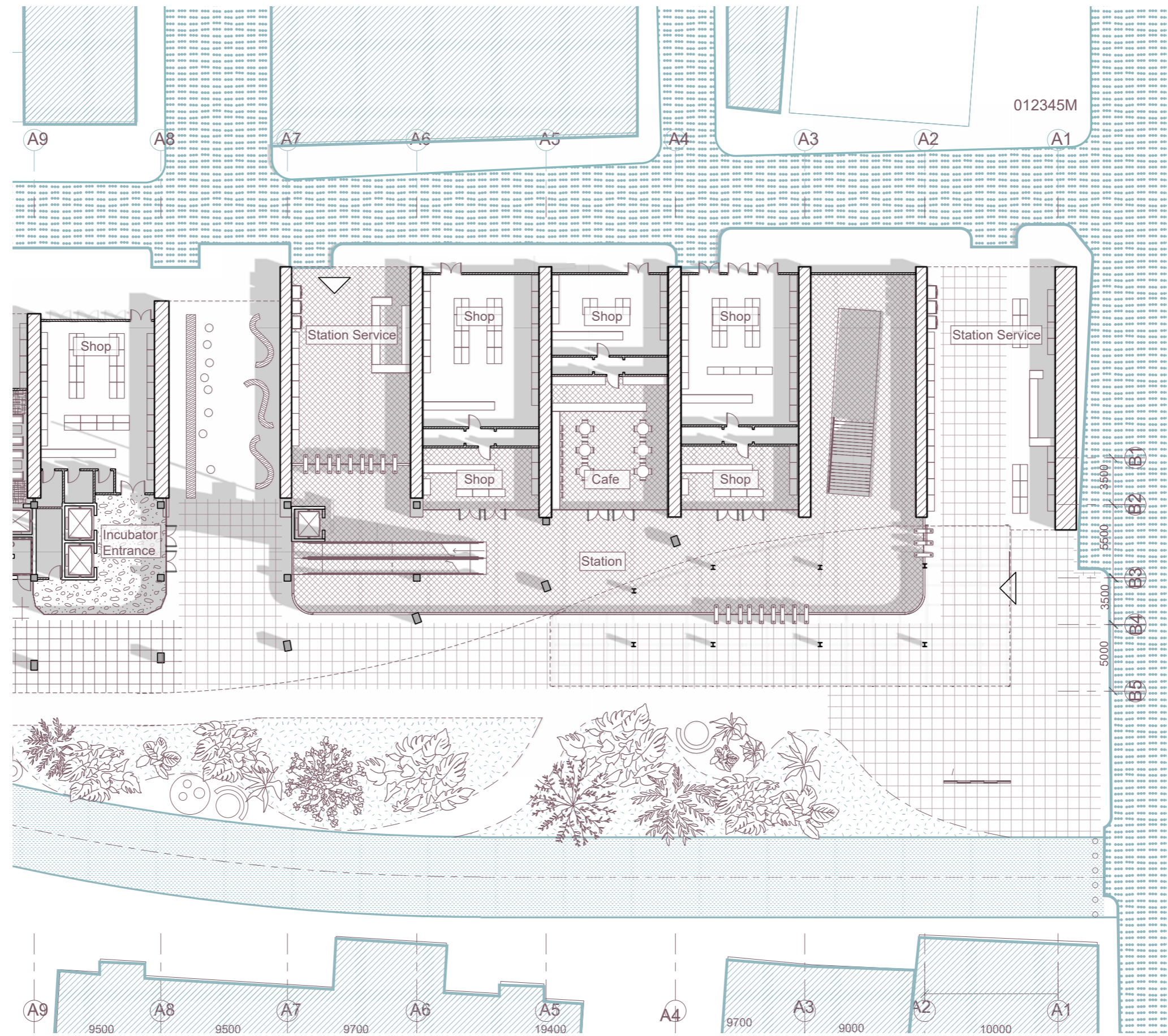



# Current Site photo





50





# Canopy Structure

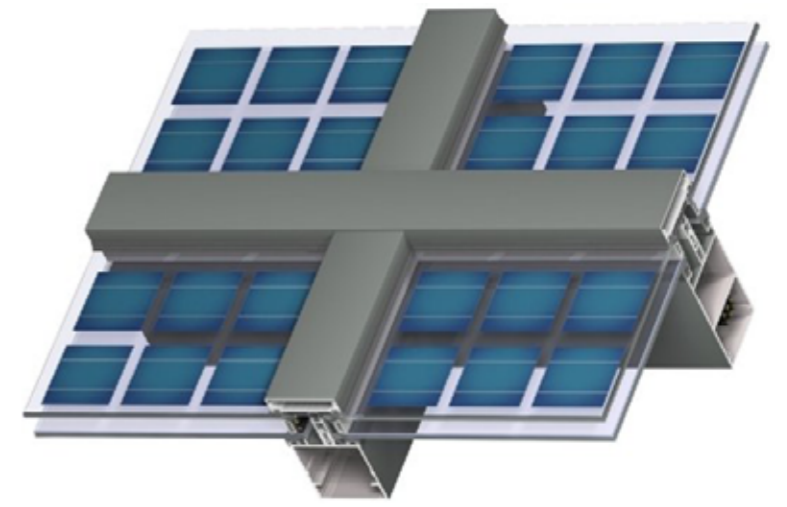
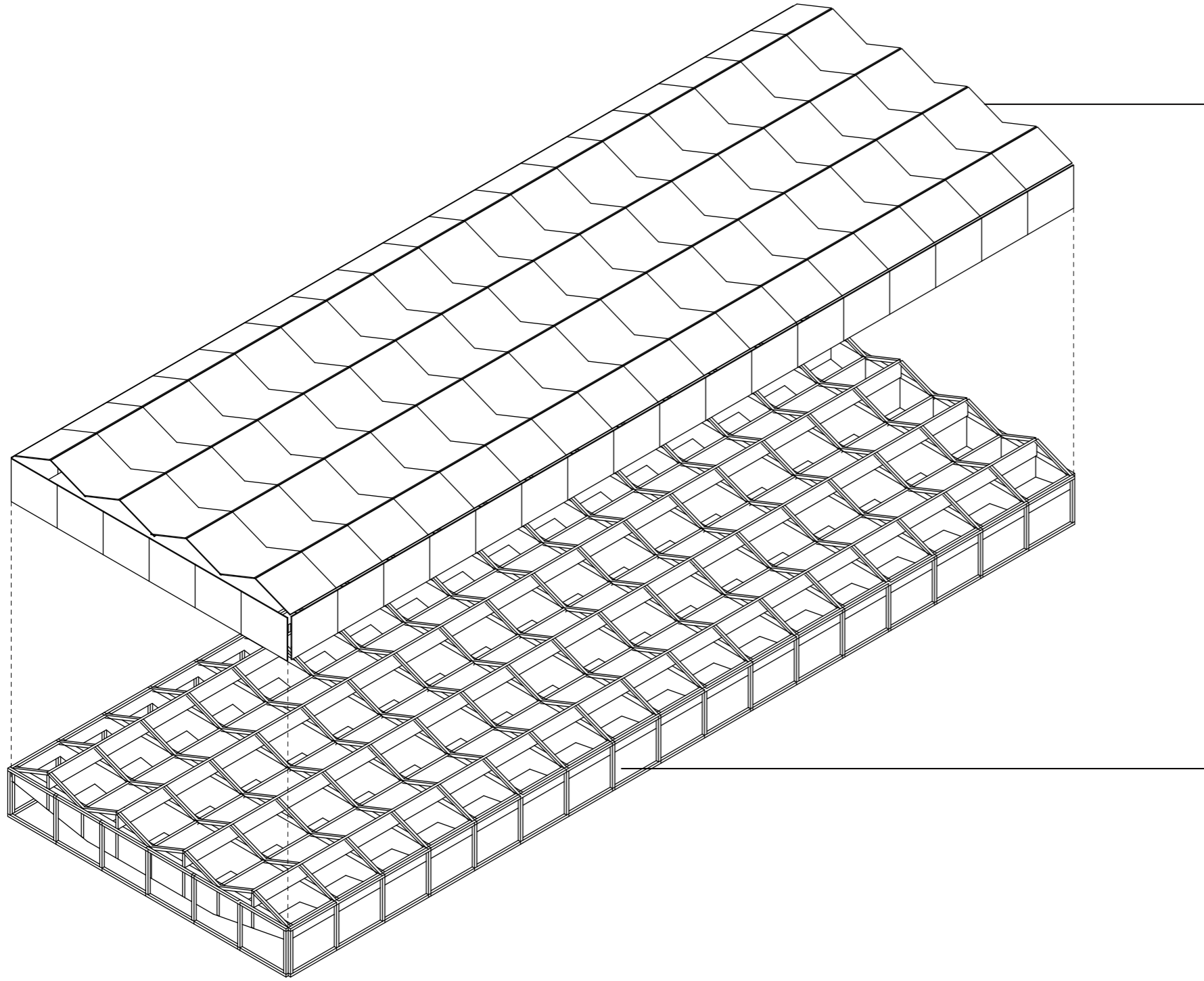

# Market and Entrances

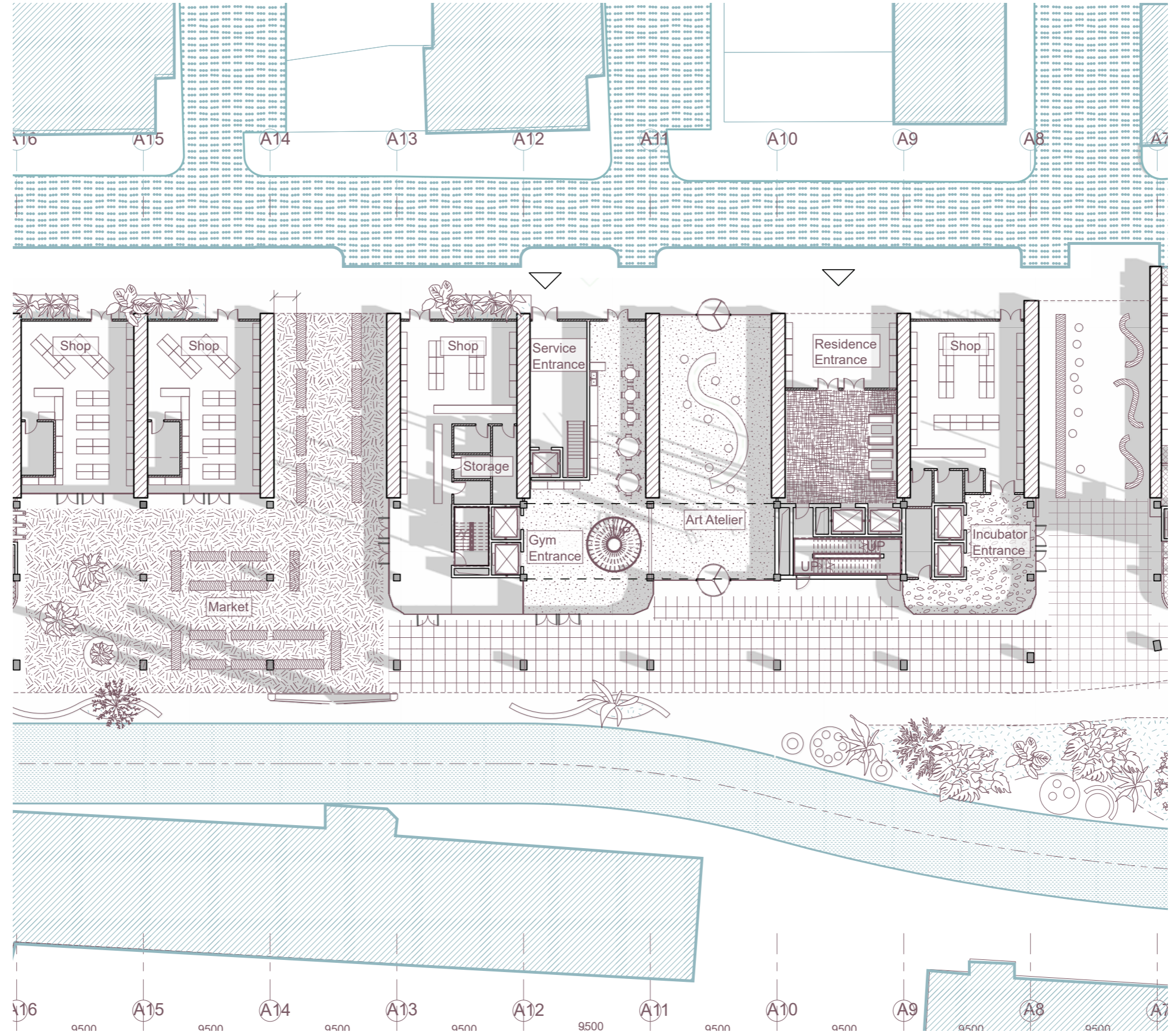







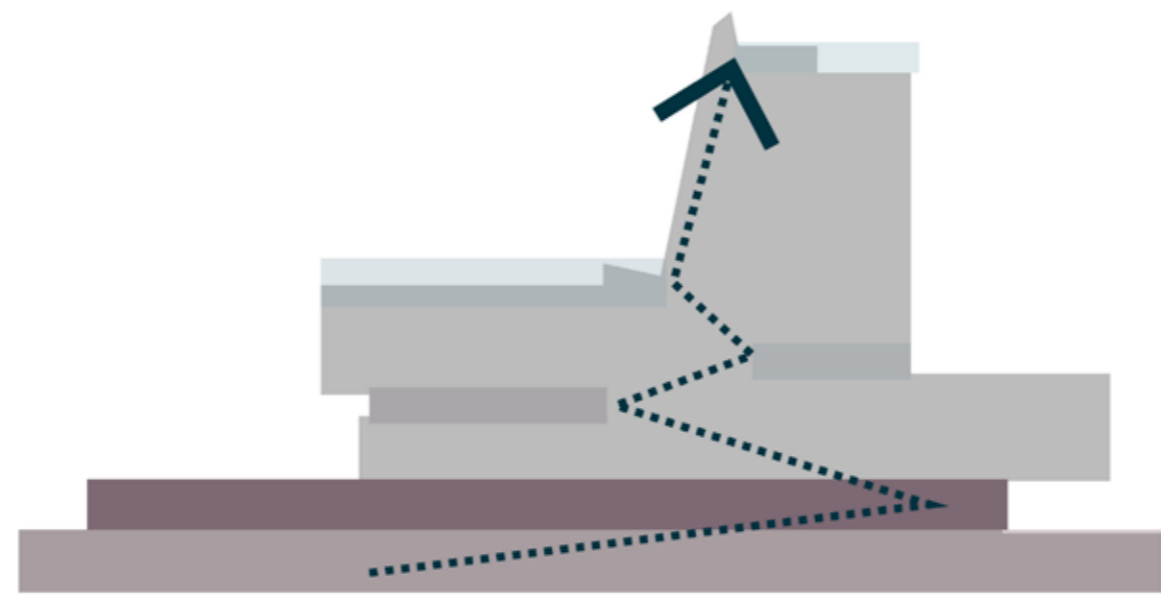

## 2. Platform



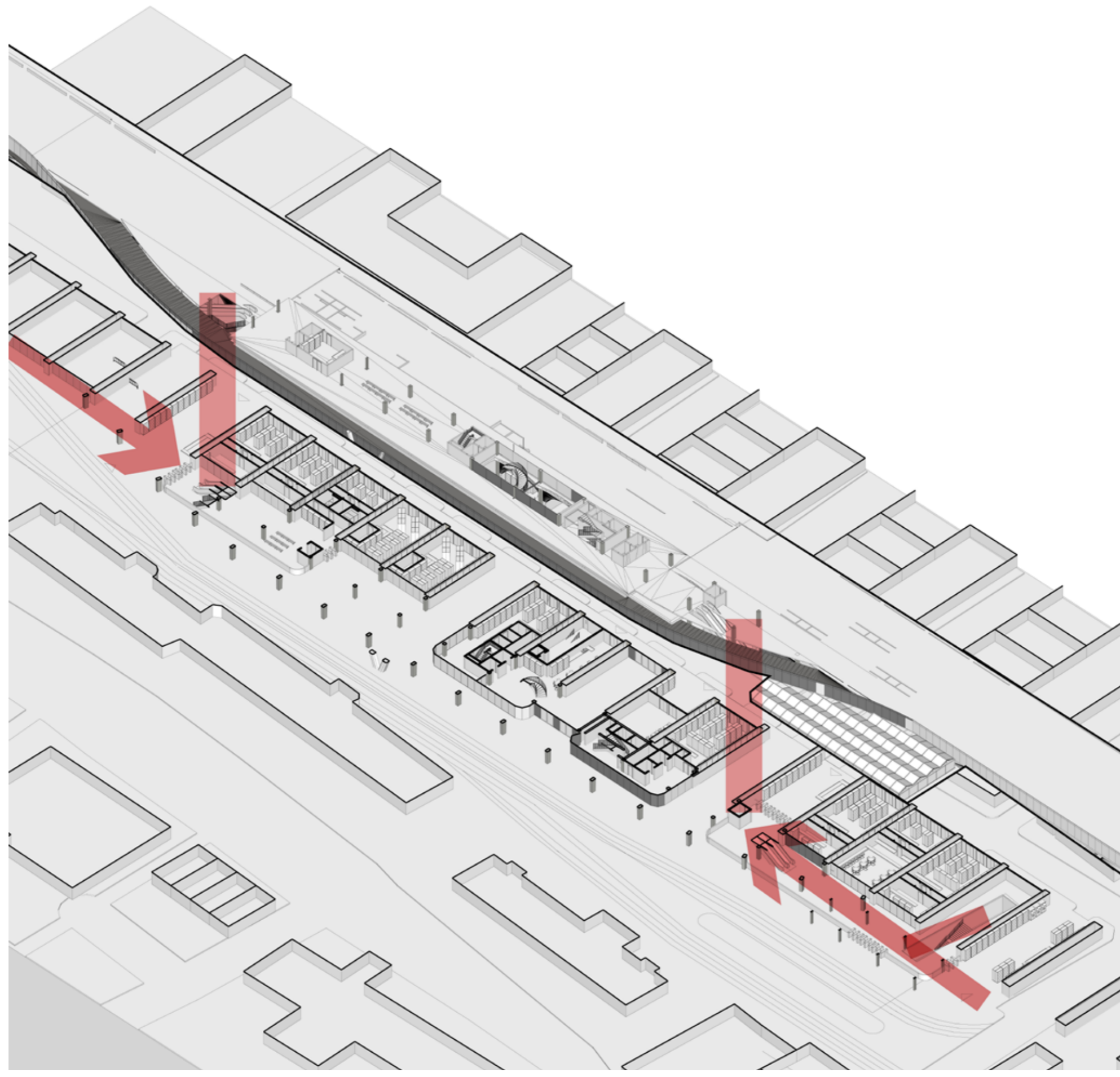

# Platform

Floor plan

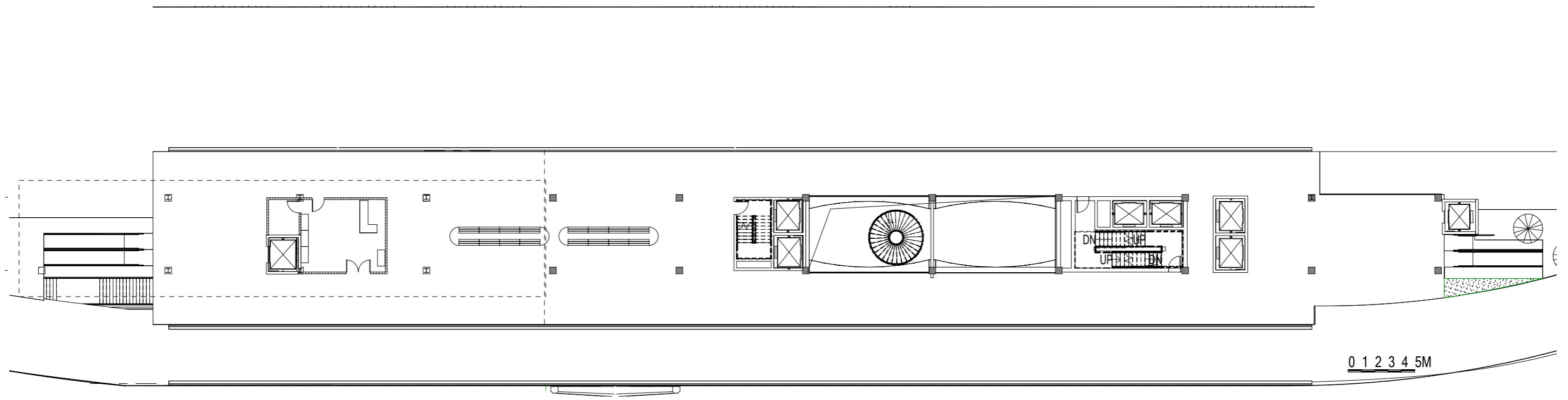











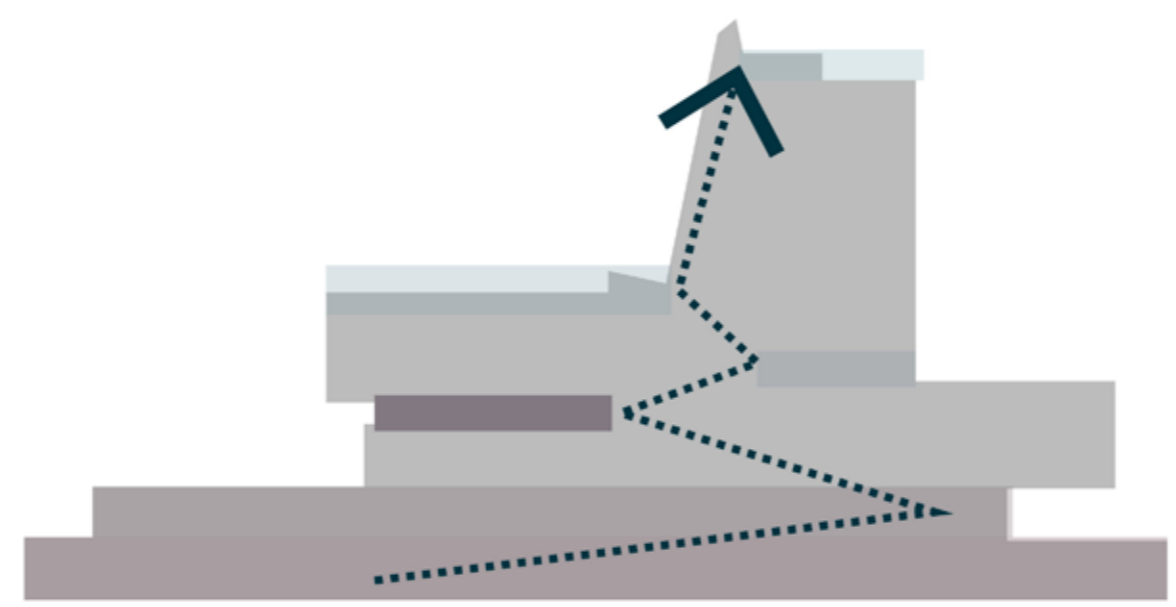

### 3. Bar/Cafe Terrace

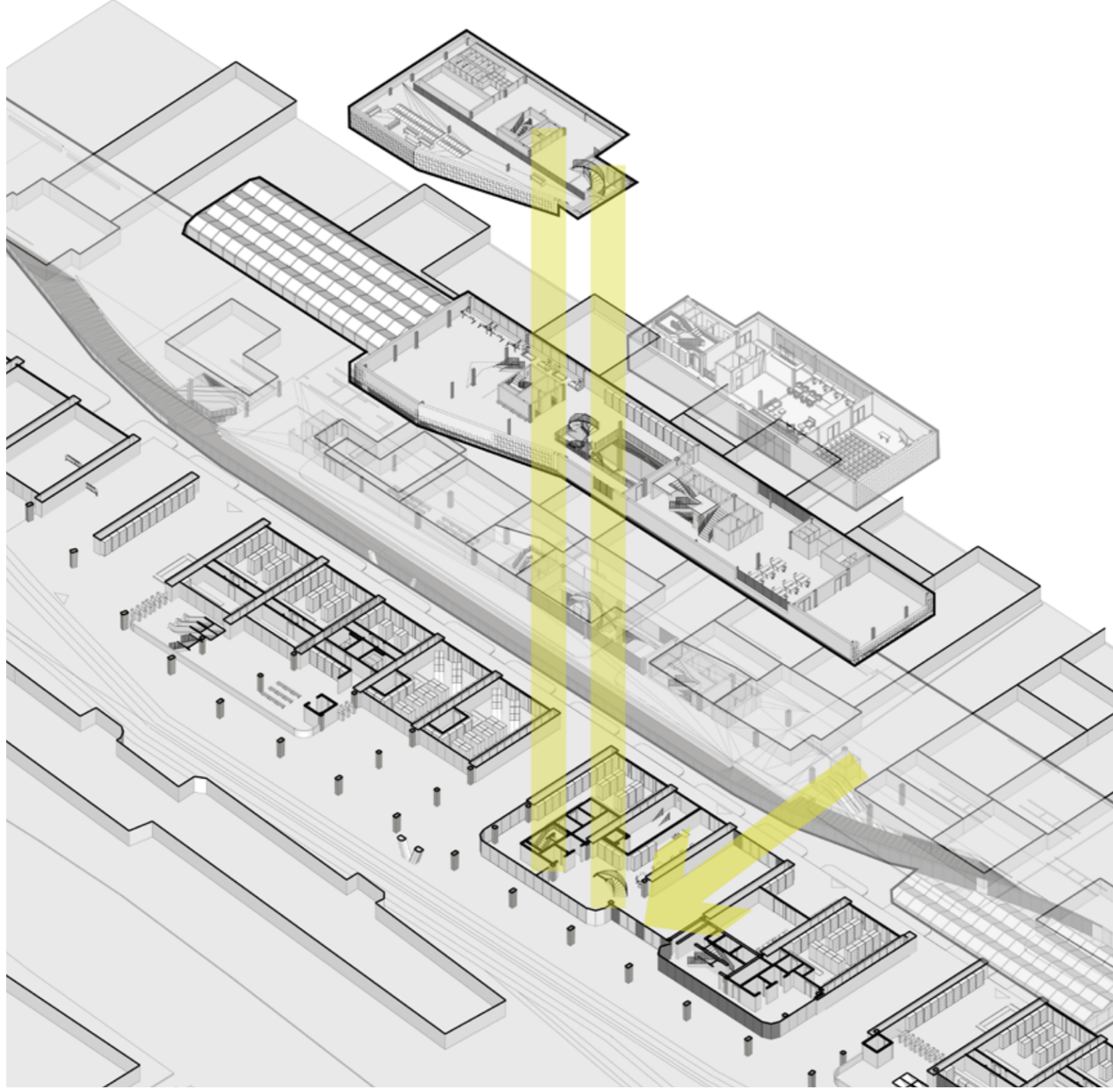



3rd Floor East  
Bar/ Cafe Terrace

61

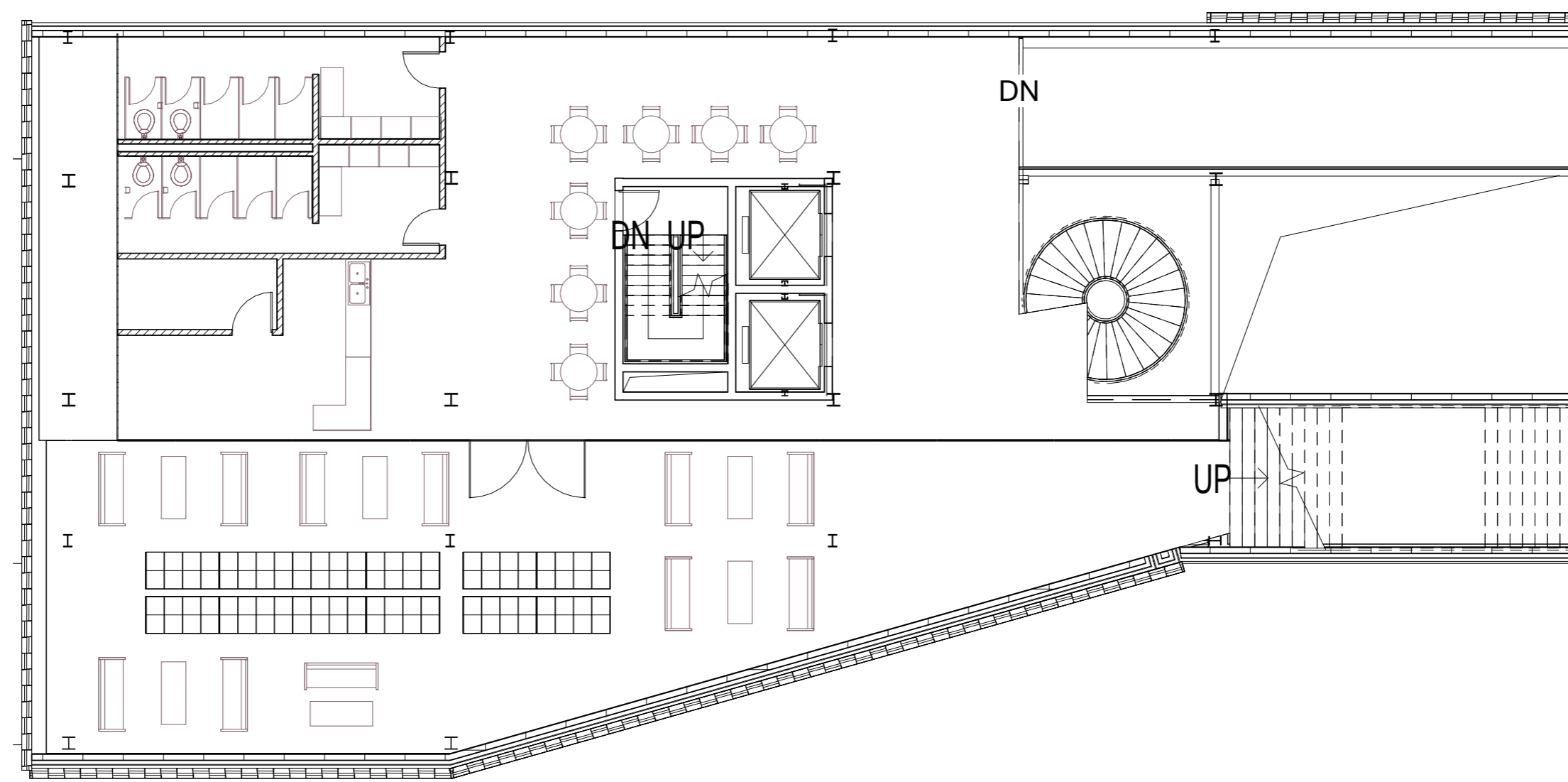









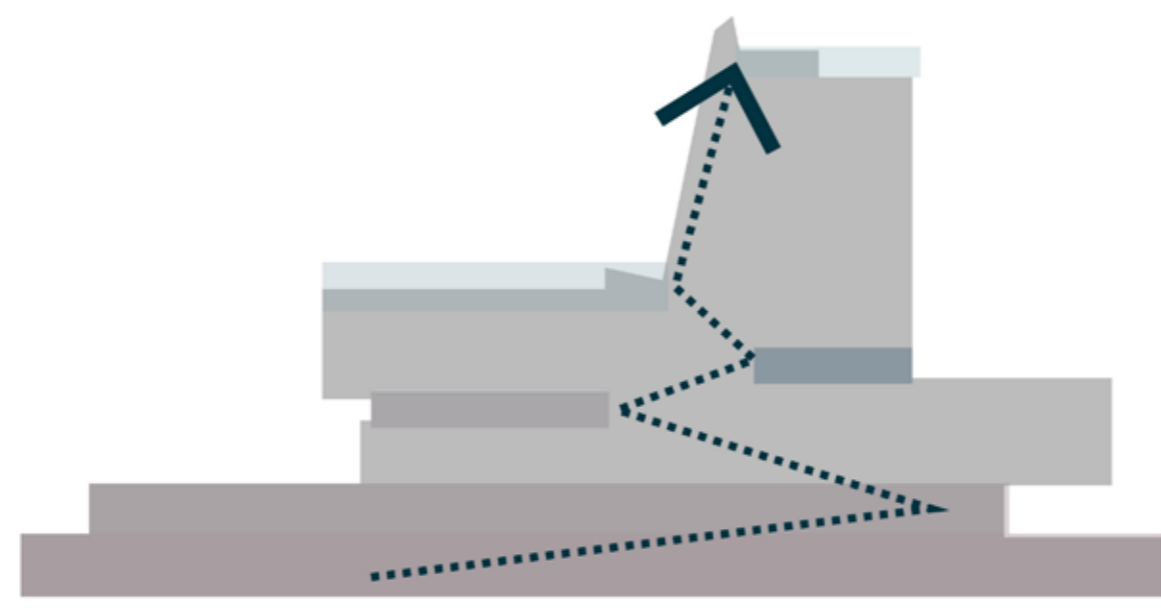

# 4. Frontyard



65

4th Floor  
Residential Level  
Amenities / Multifunctional Room / Living Units

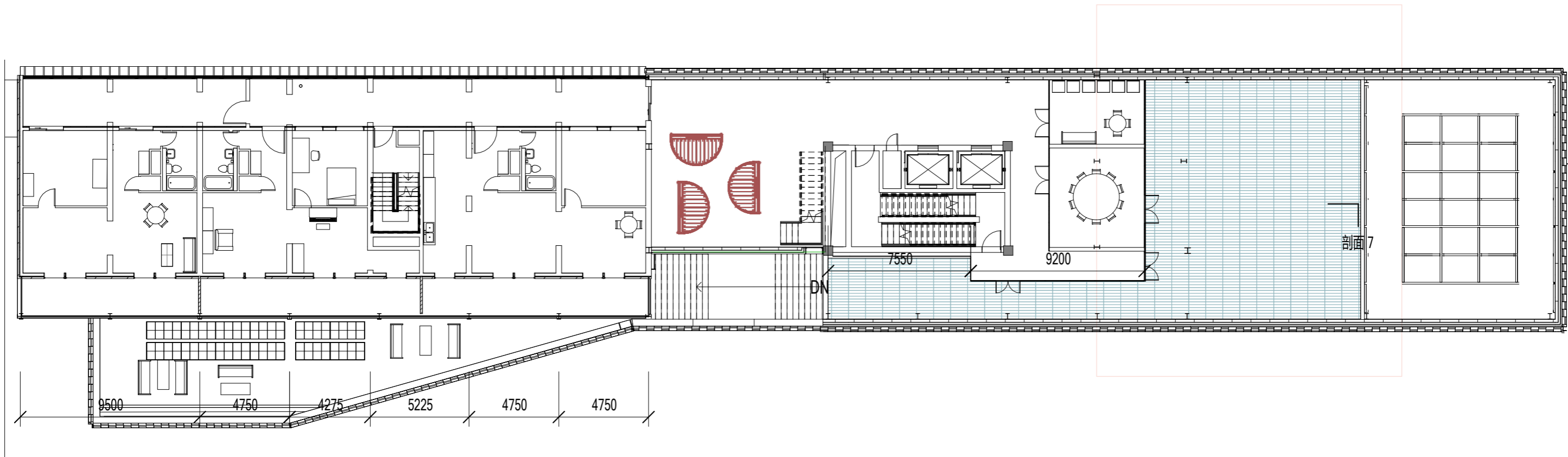







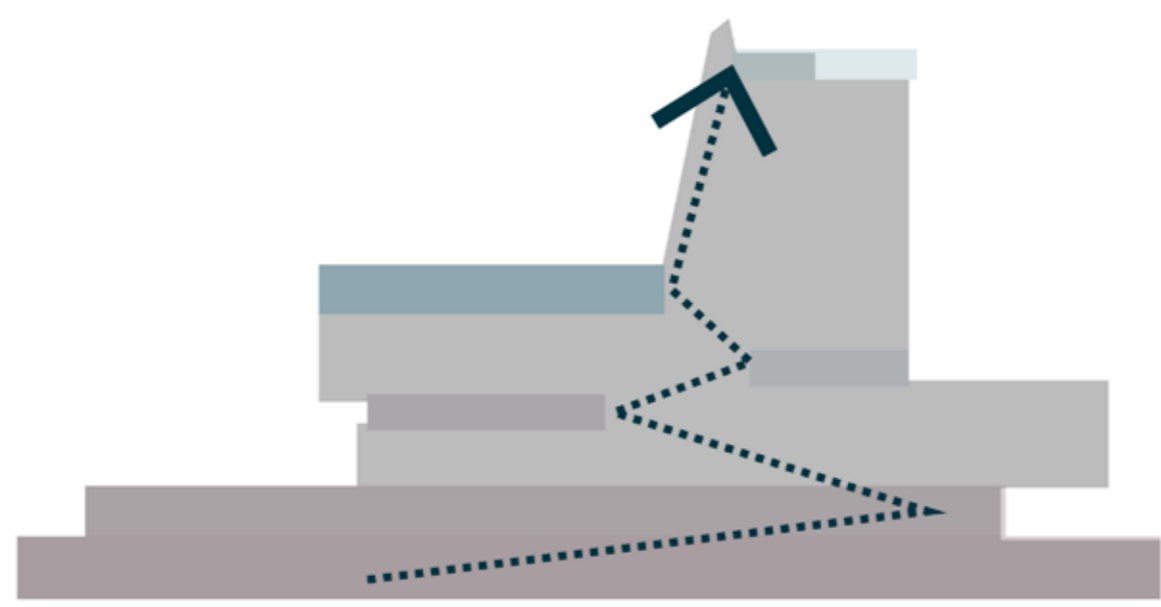

# 5. Vegetation Level

7th Floor  
vegetation Level  
Detail Section  
Community Garden, raised flower bed

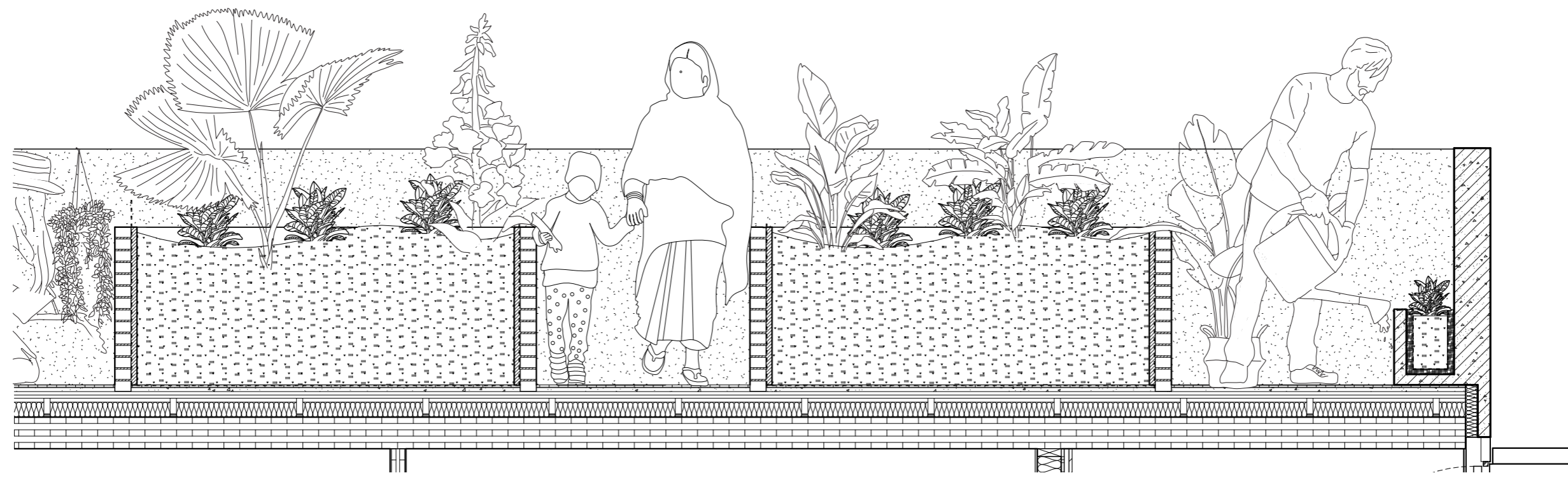



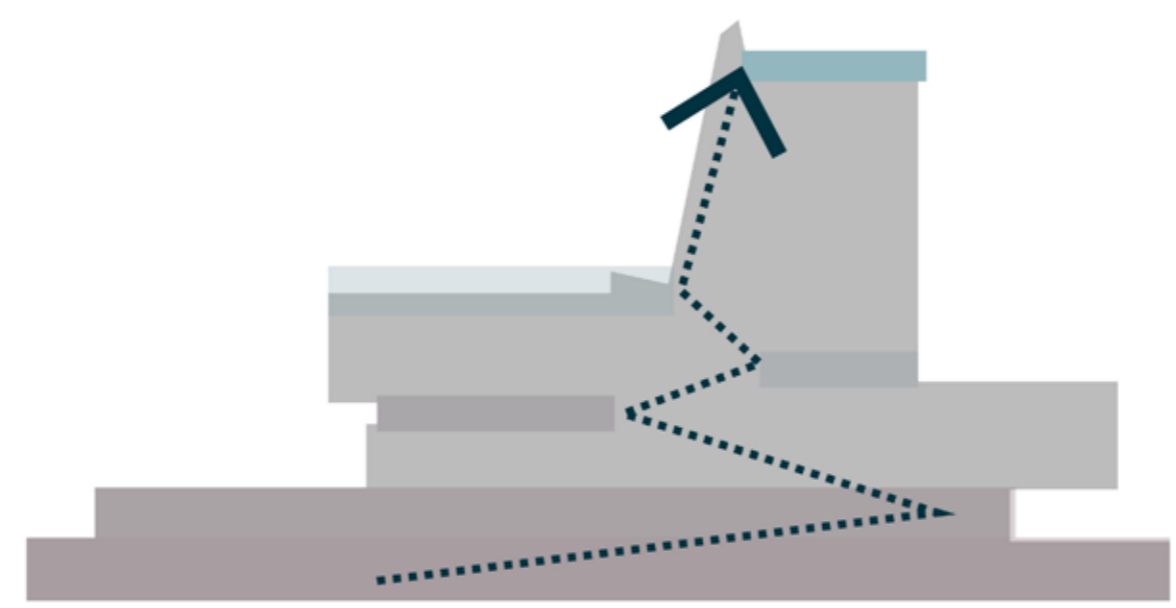

## 6. Roof

# Roof vision





# 2, Vertical Atrium

P5 PRESENTATION

ADC 2022/2023

71

June 30th, 2023

5504295

Deying Chen

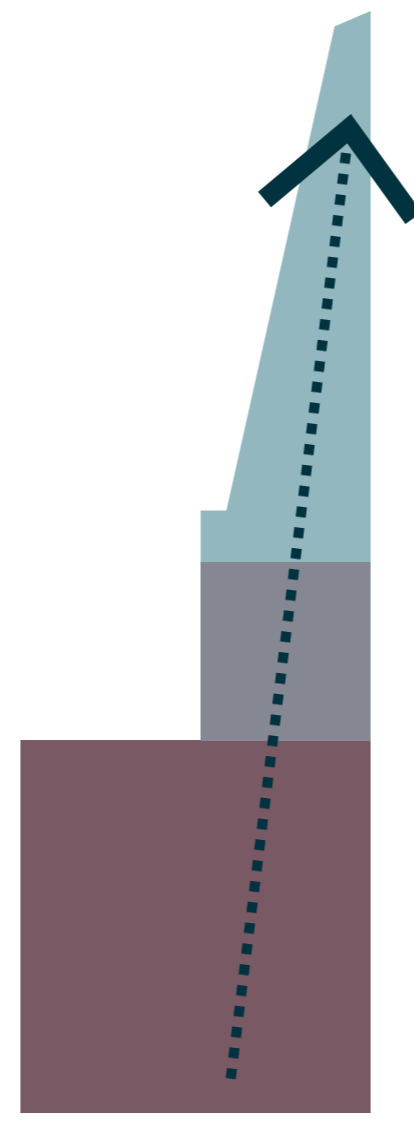

# Section Perspective

## Atrium

72

3. Climate Atrium

2. Communication

1. Art Atelier

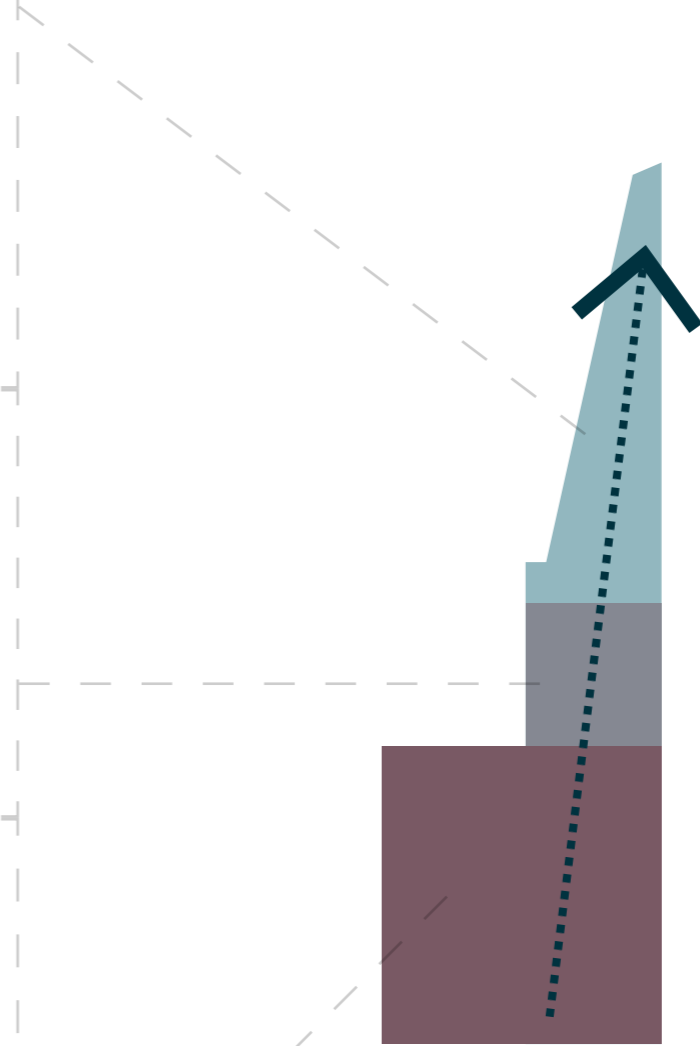
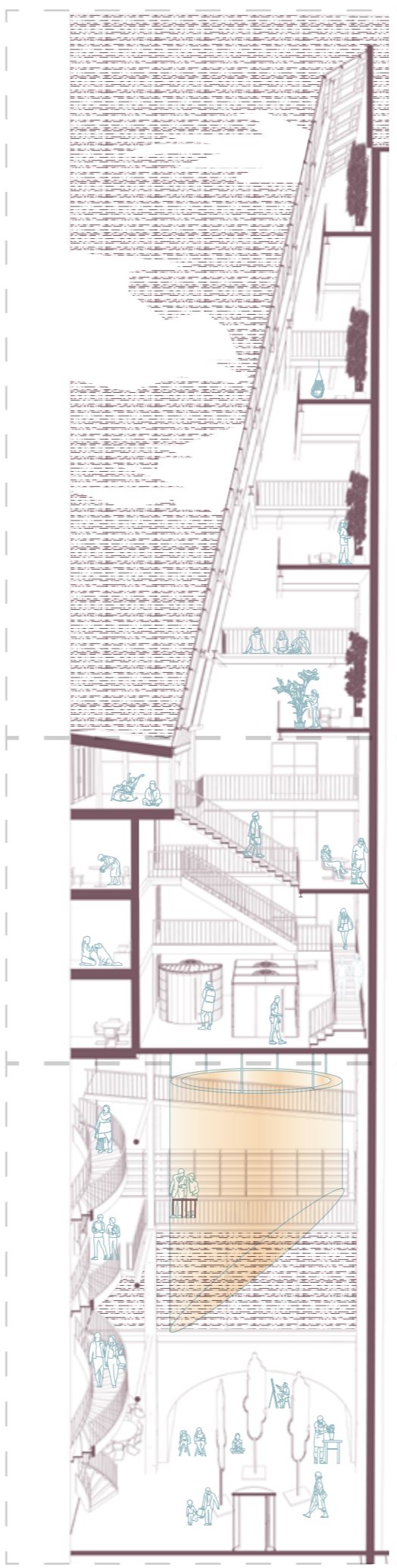



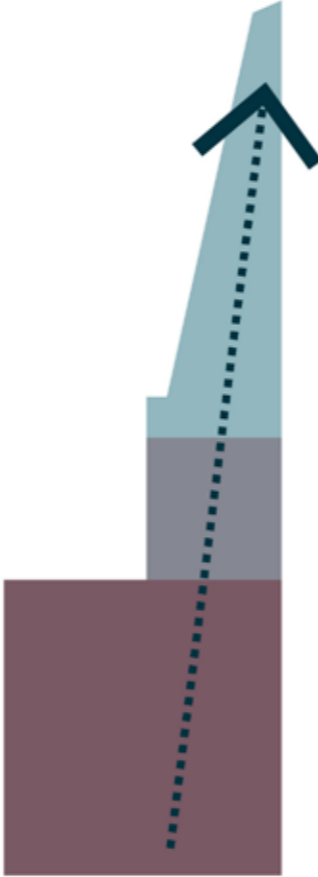

1. Art Atelier

# Art Atelier

Section Perspective

74

Gym Entrance

Showroom

Hanging Art Work

Glass to Platform

Art Atelier

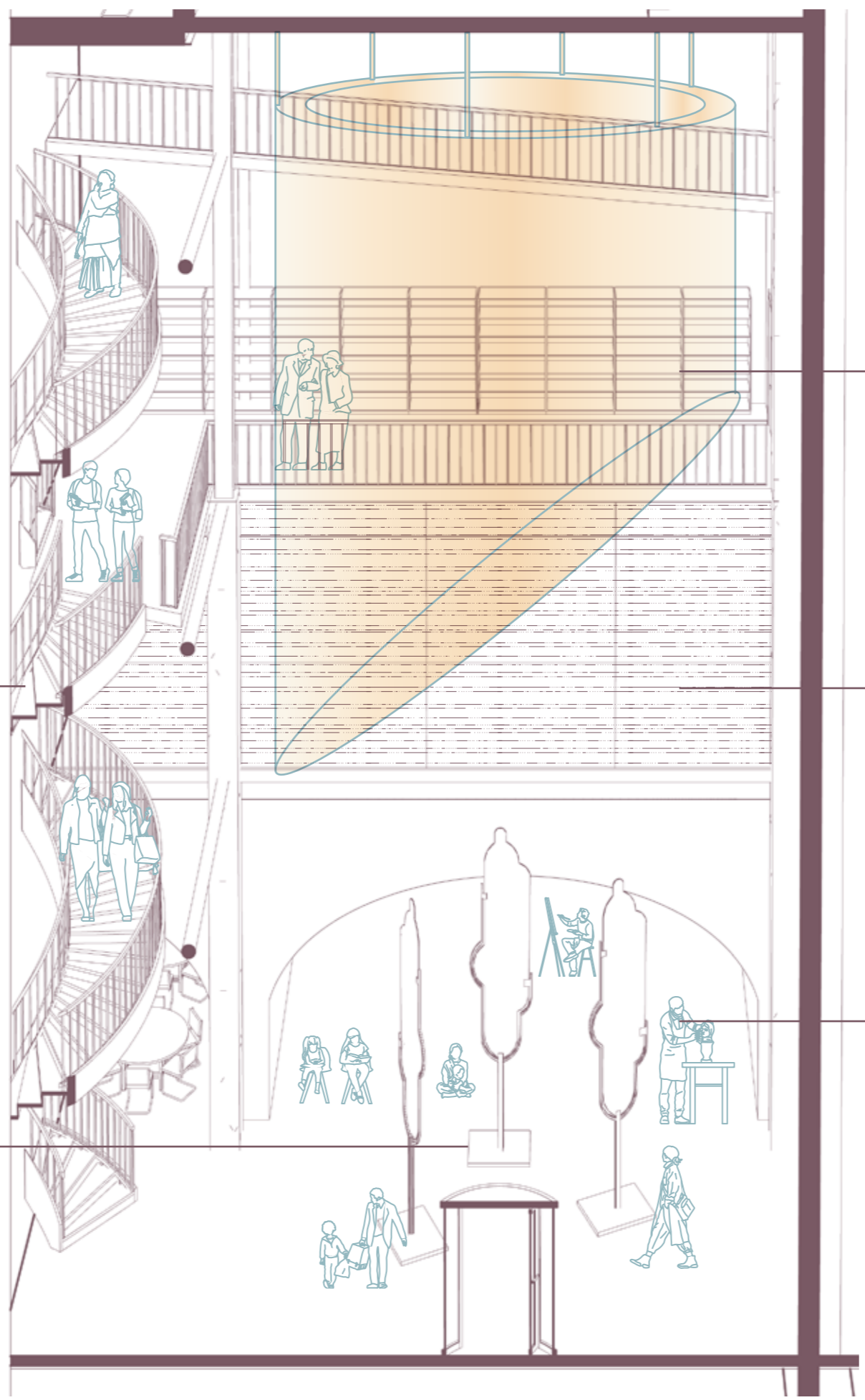







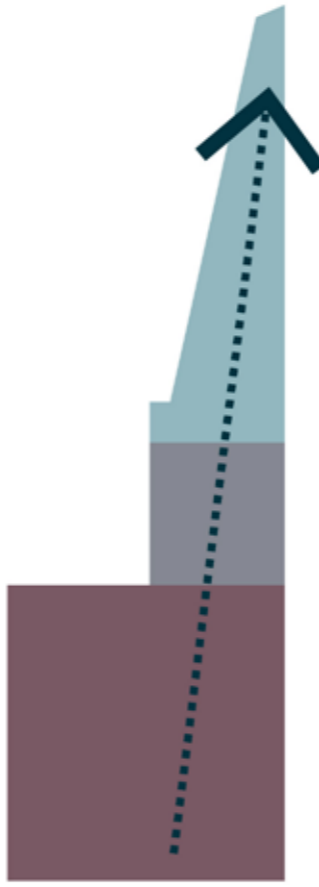

## 2. Communication



# Communication Space

Section Perspective

Towards vegetation Level

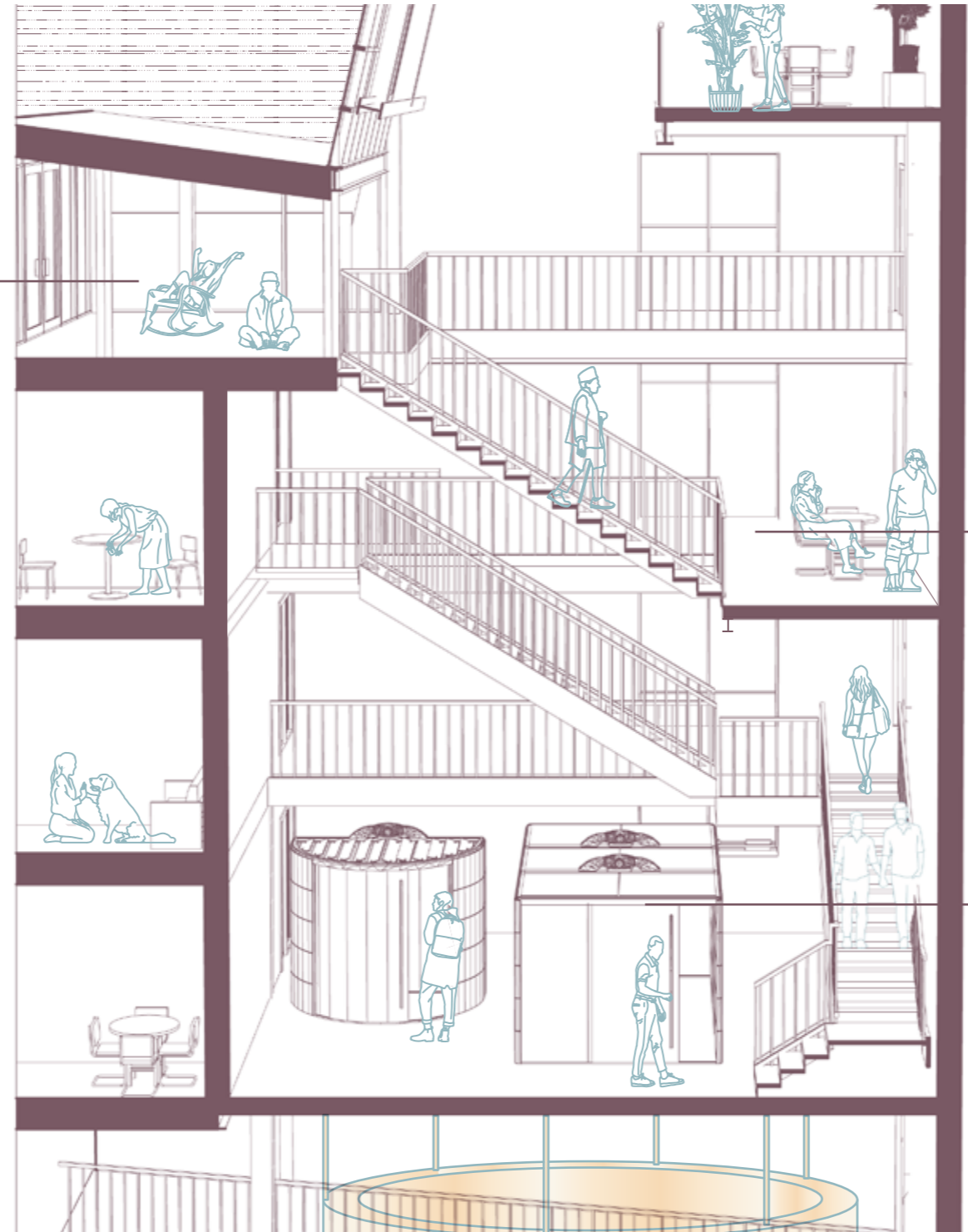

Shared Communication Space

Acoustic Box

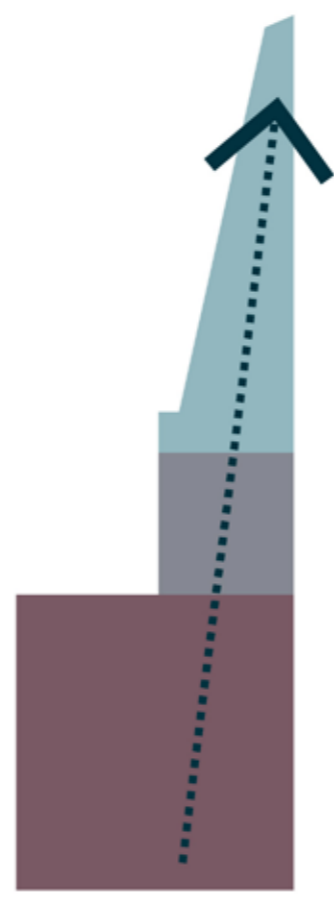

### 3. Climate Atrium



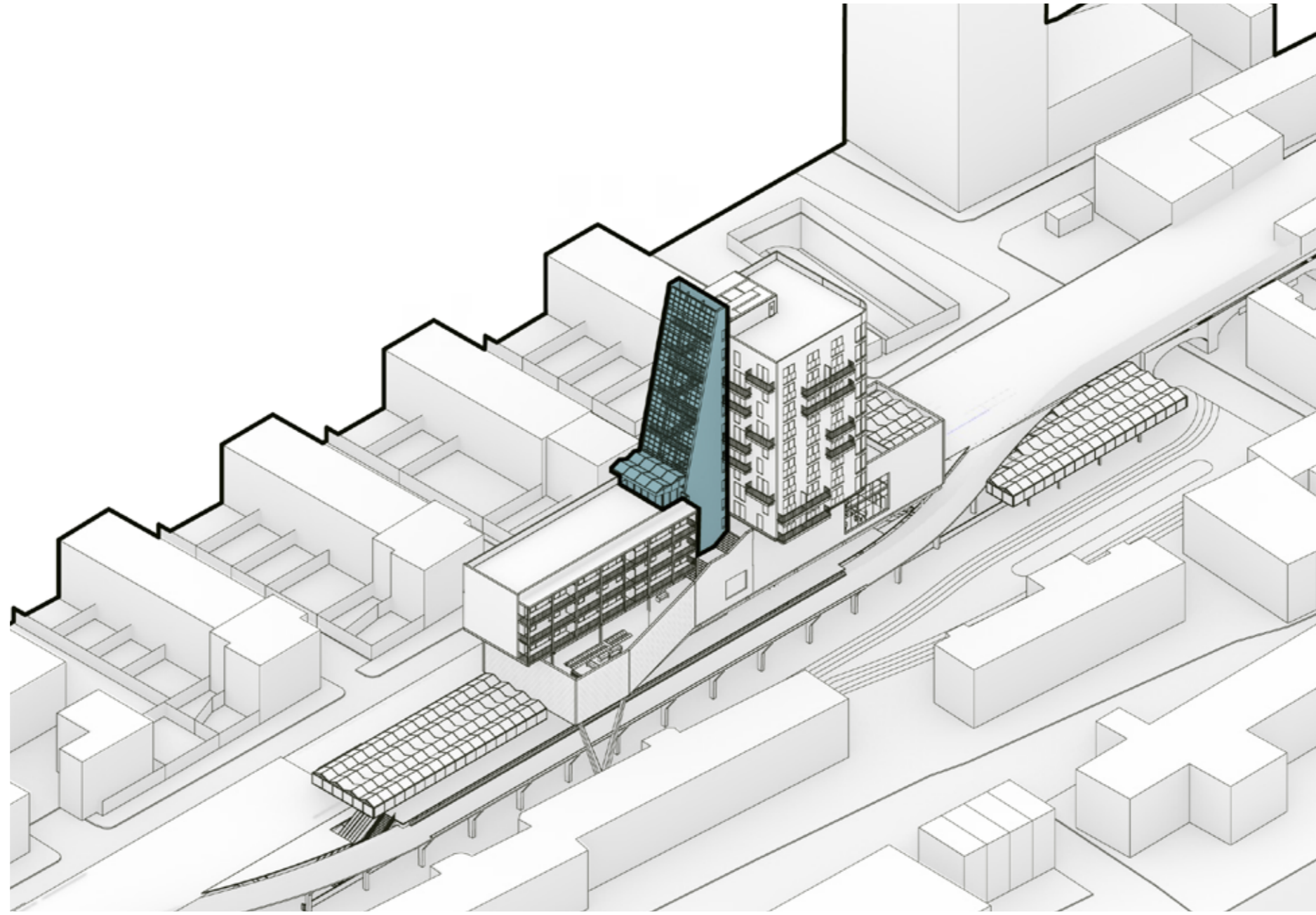

# Climate Atrium

Section Perspective

80

Glazing

Climate Atrium

Greenwall





# Climate Atrium

Section  
Ventilation  
Water Circulation

81

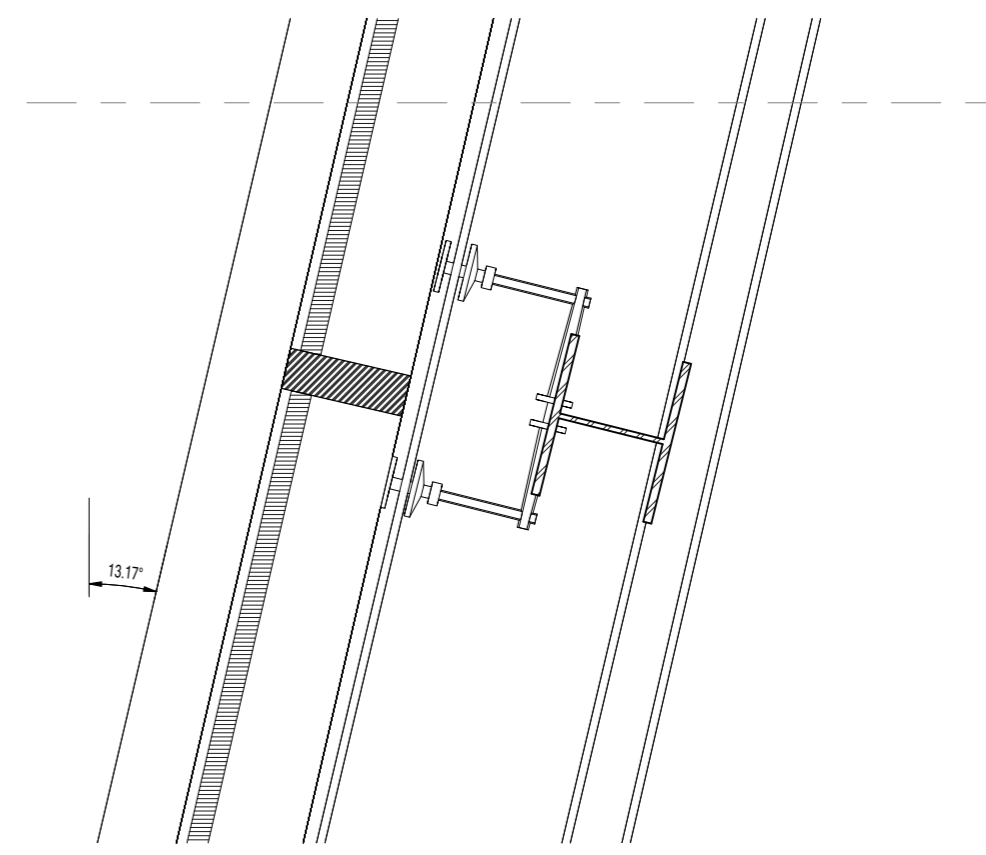
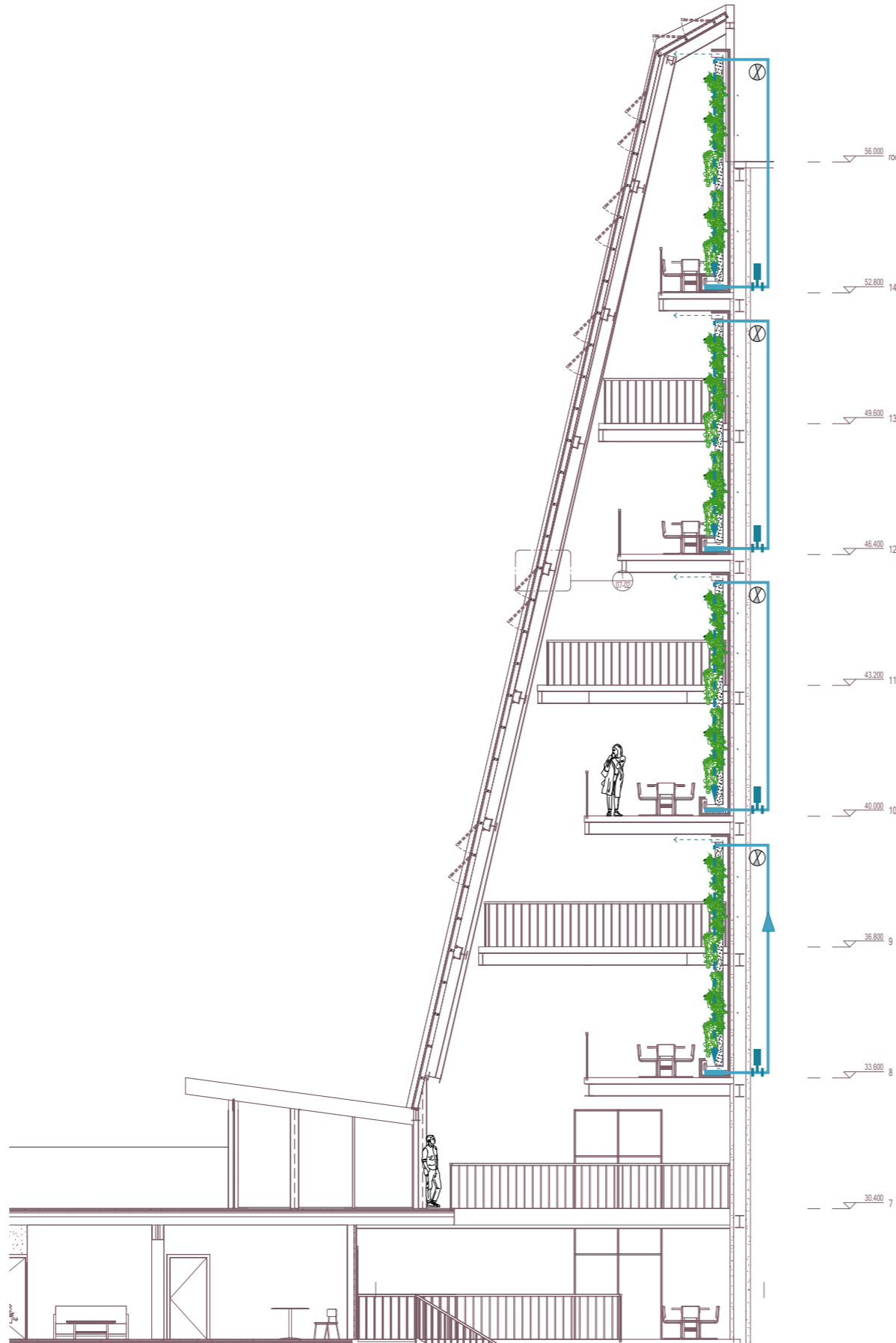

**Detail**  
Glazing connection with structure  
Support Elements

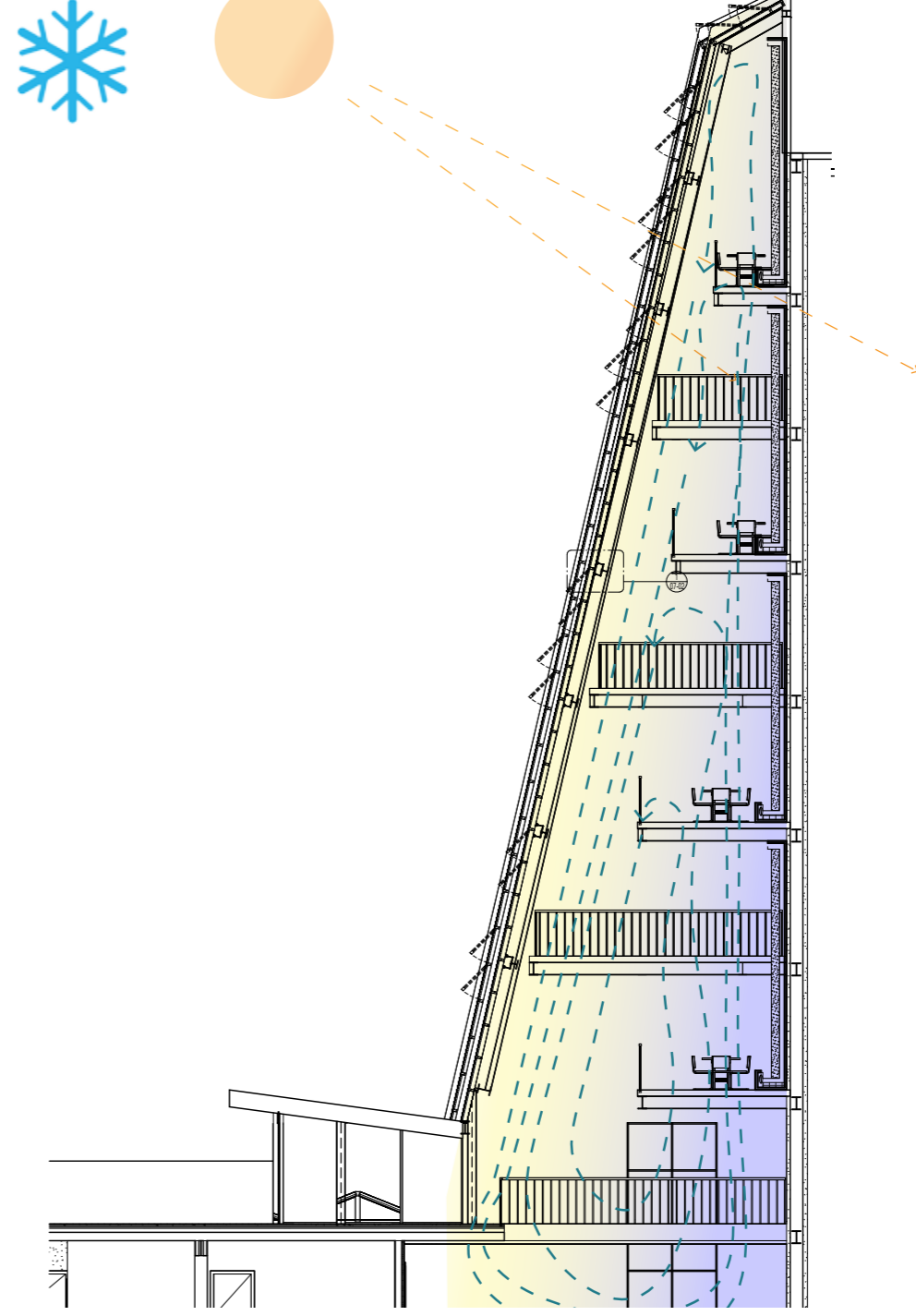
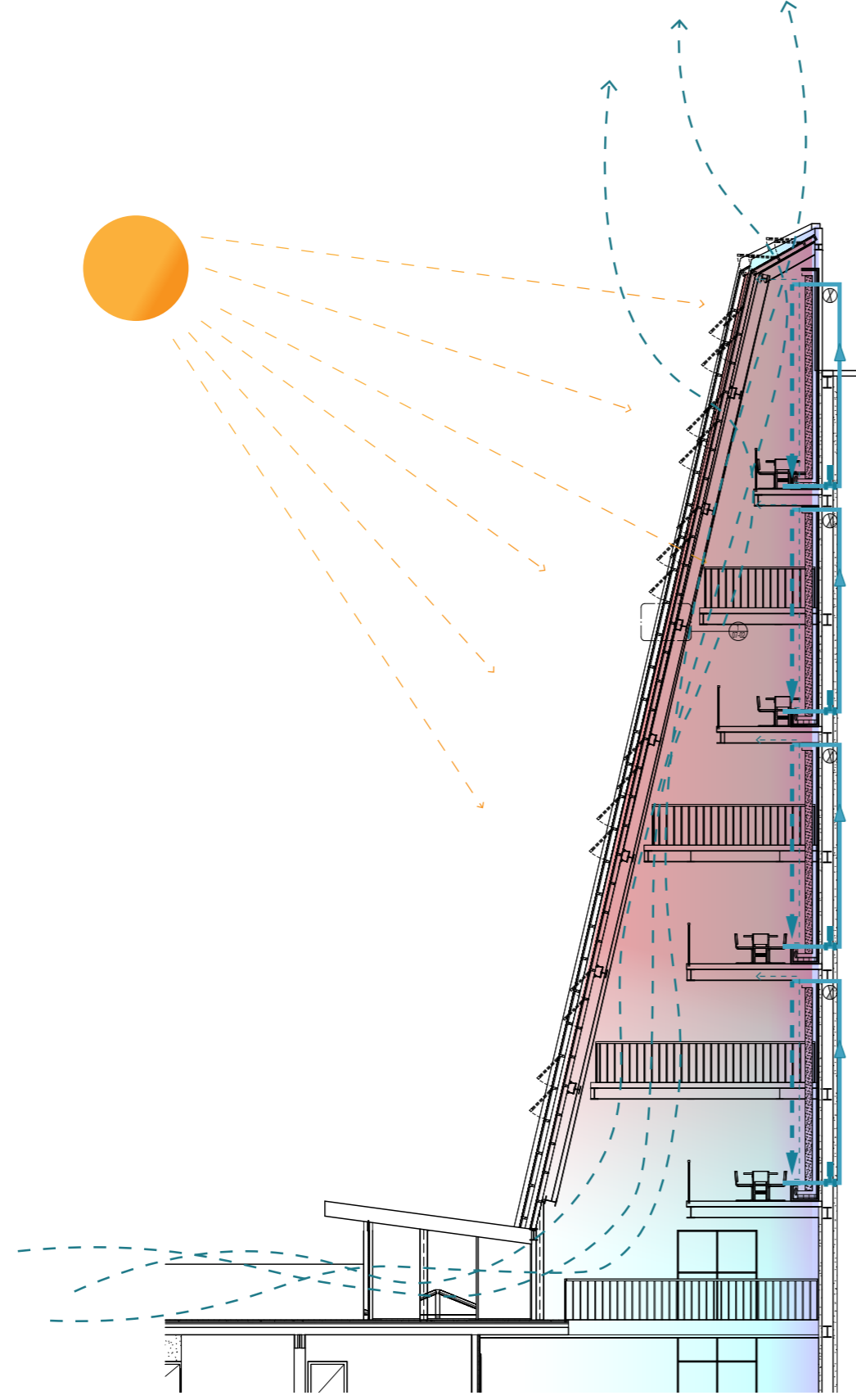



# Bouldering Gym

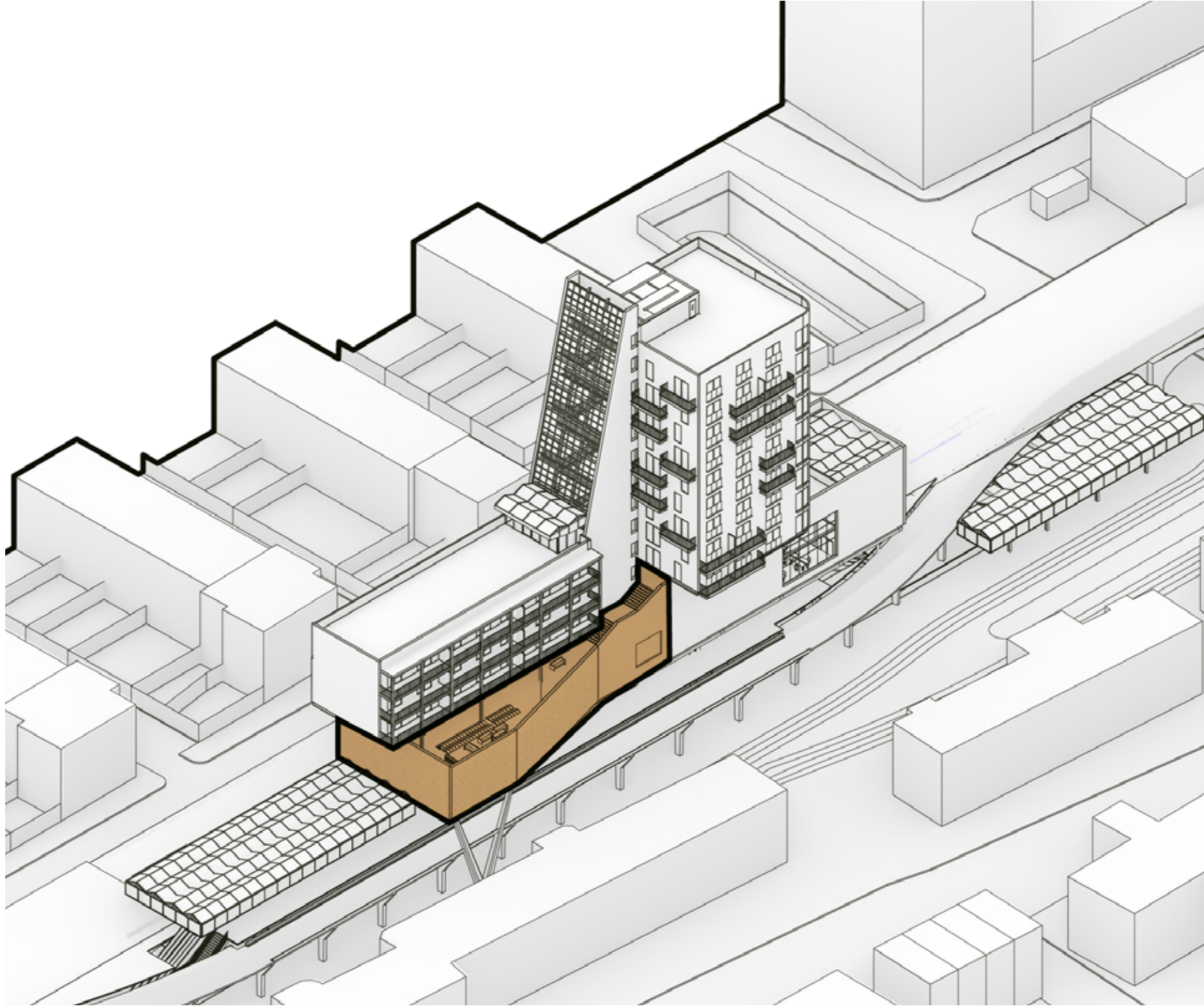

# Bouldering Gym

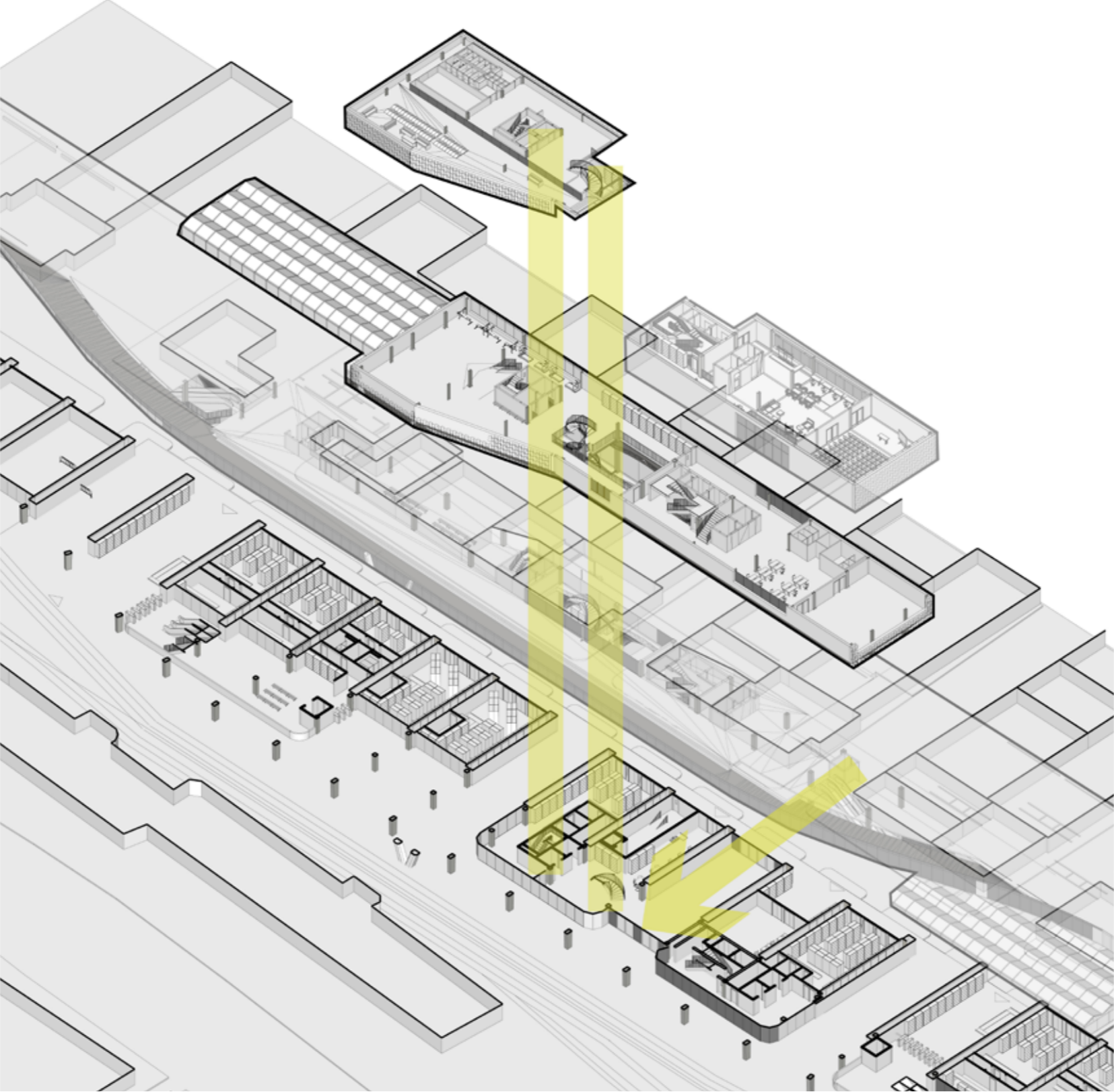



# Challenges

85



1, Spatial Requirements



2, Noise Pollution

# Floor Plans

3rd Floor East  
(Bouldering) Gym  
Bar / Changing Room/ Terrace

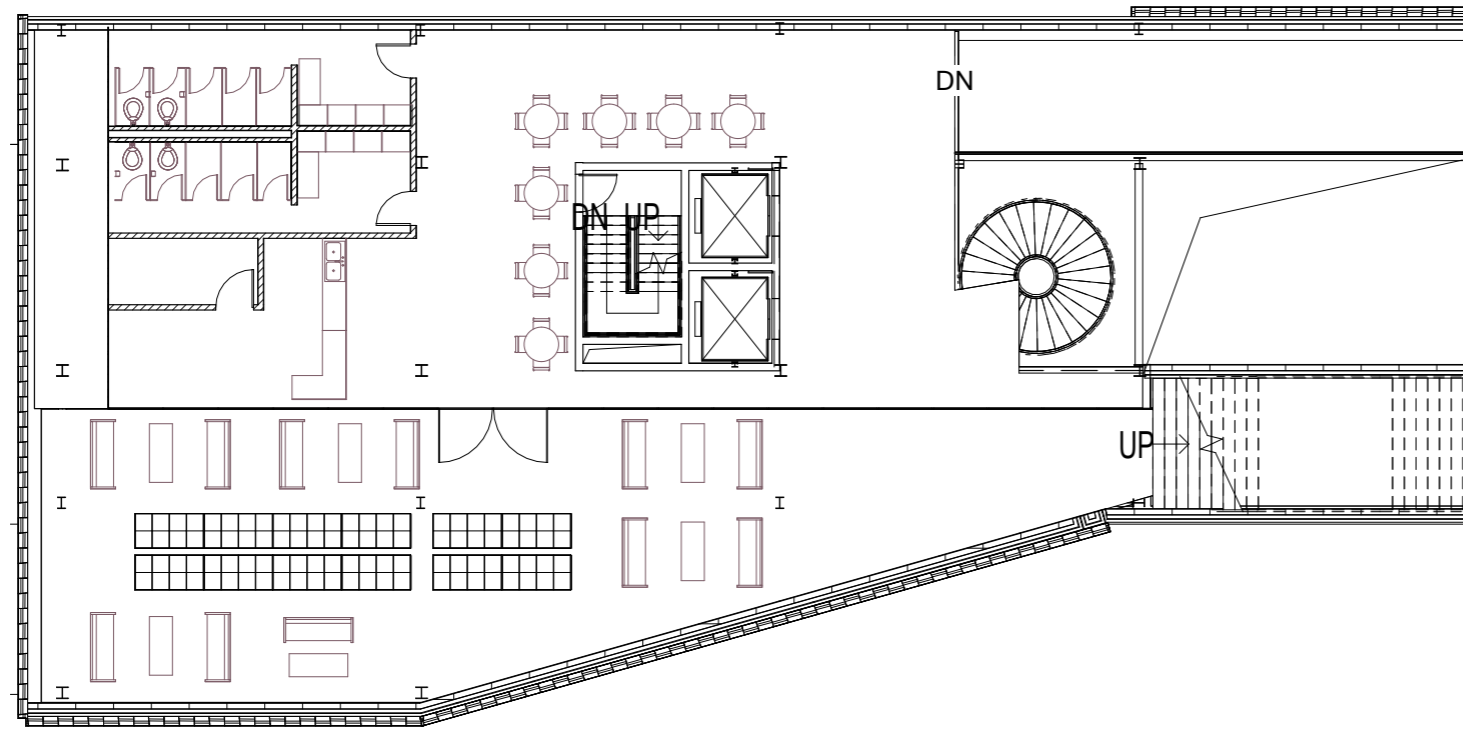

86

2nd Floor East  
(Bouldering) Gym  
Double Height Space

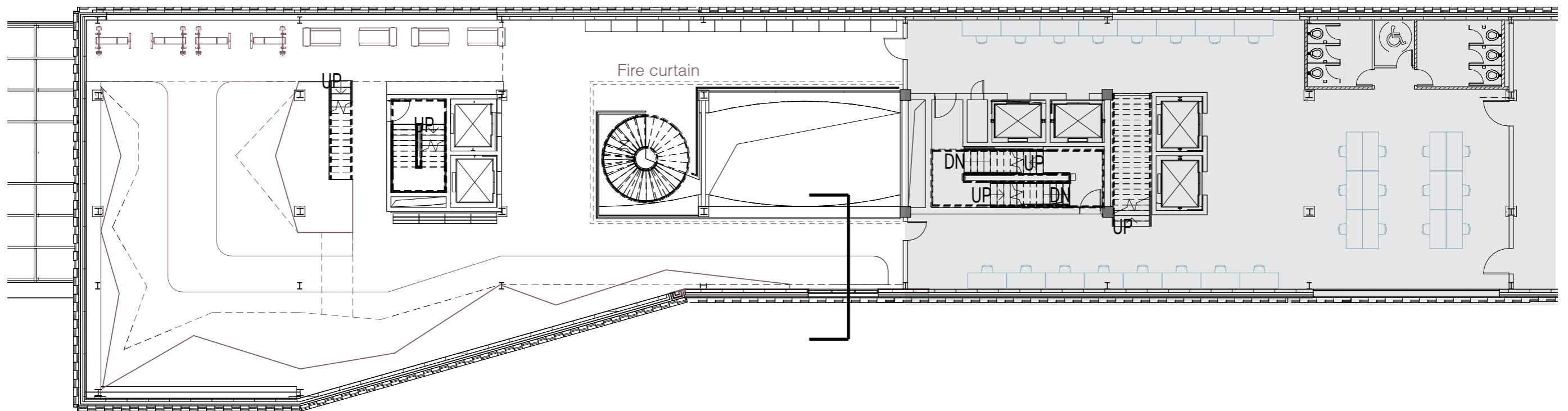



# Elevation

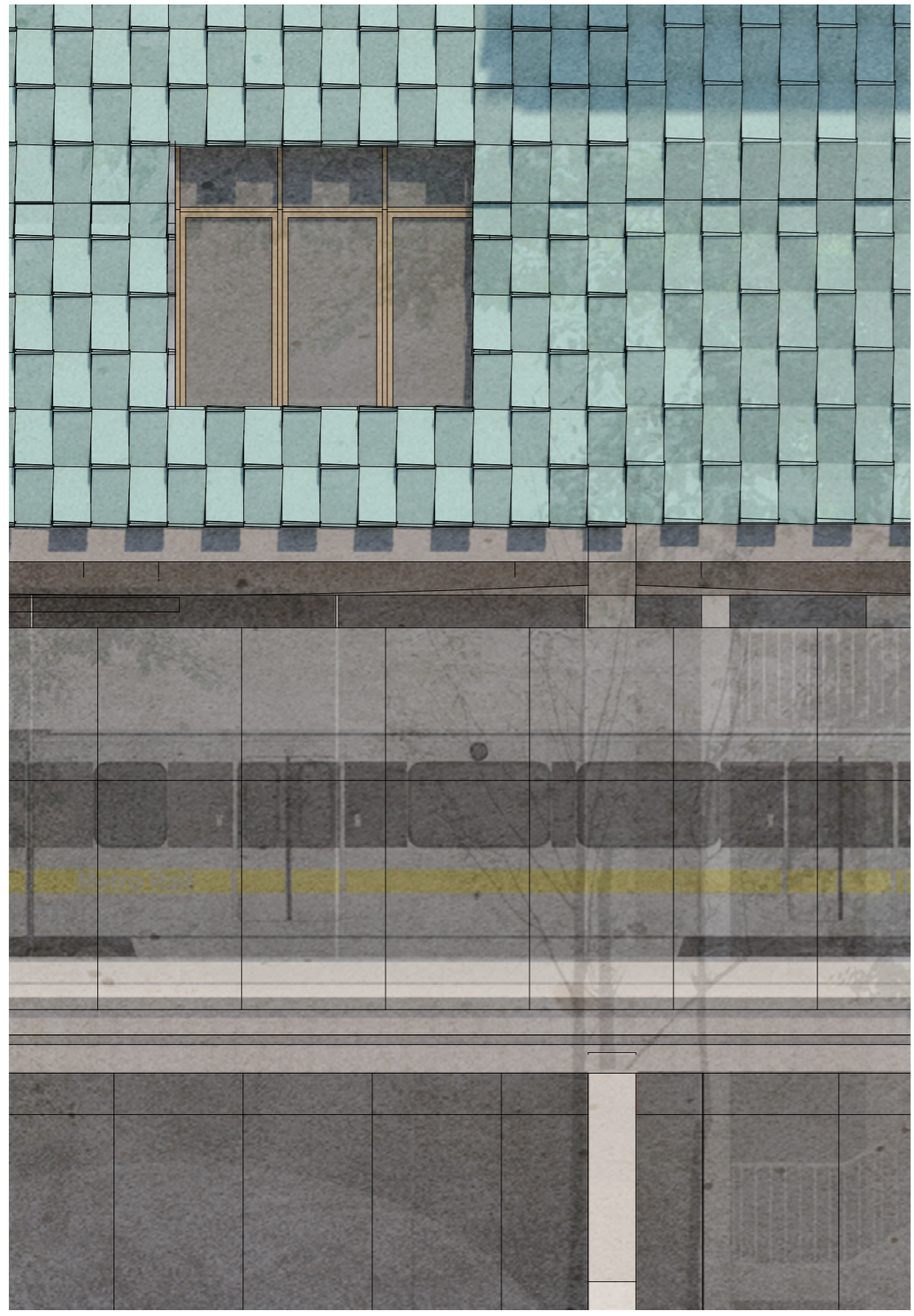

# Section

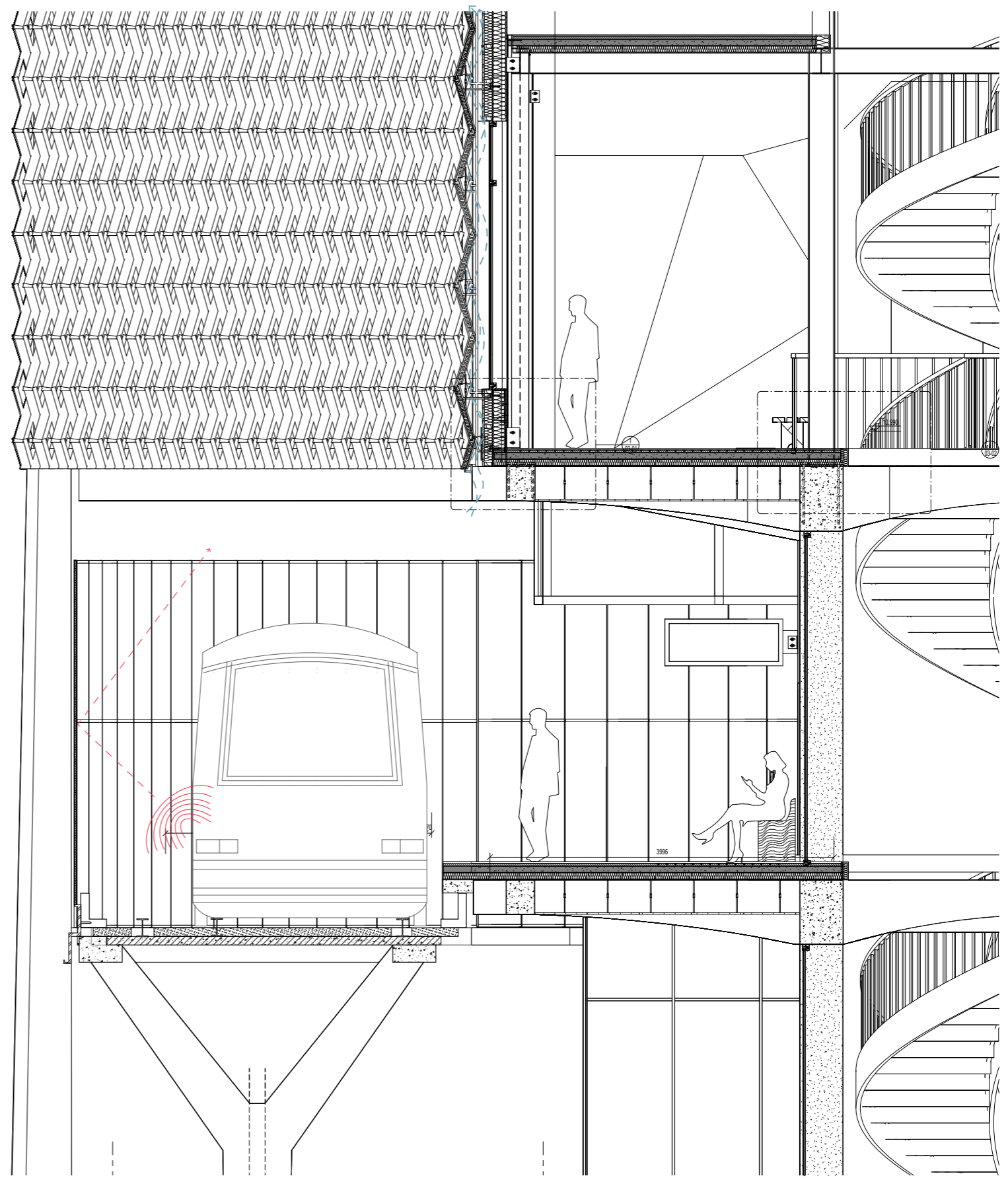

# Detail

Ventilated Facade  
Steel Support of the ceramic panels  
Double Insulated  
Connection of drywall to main Stucture

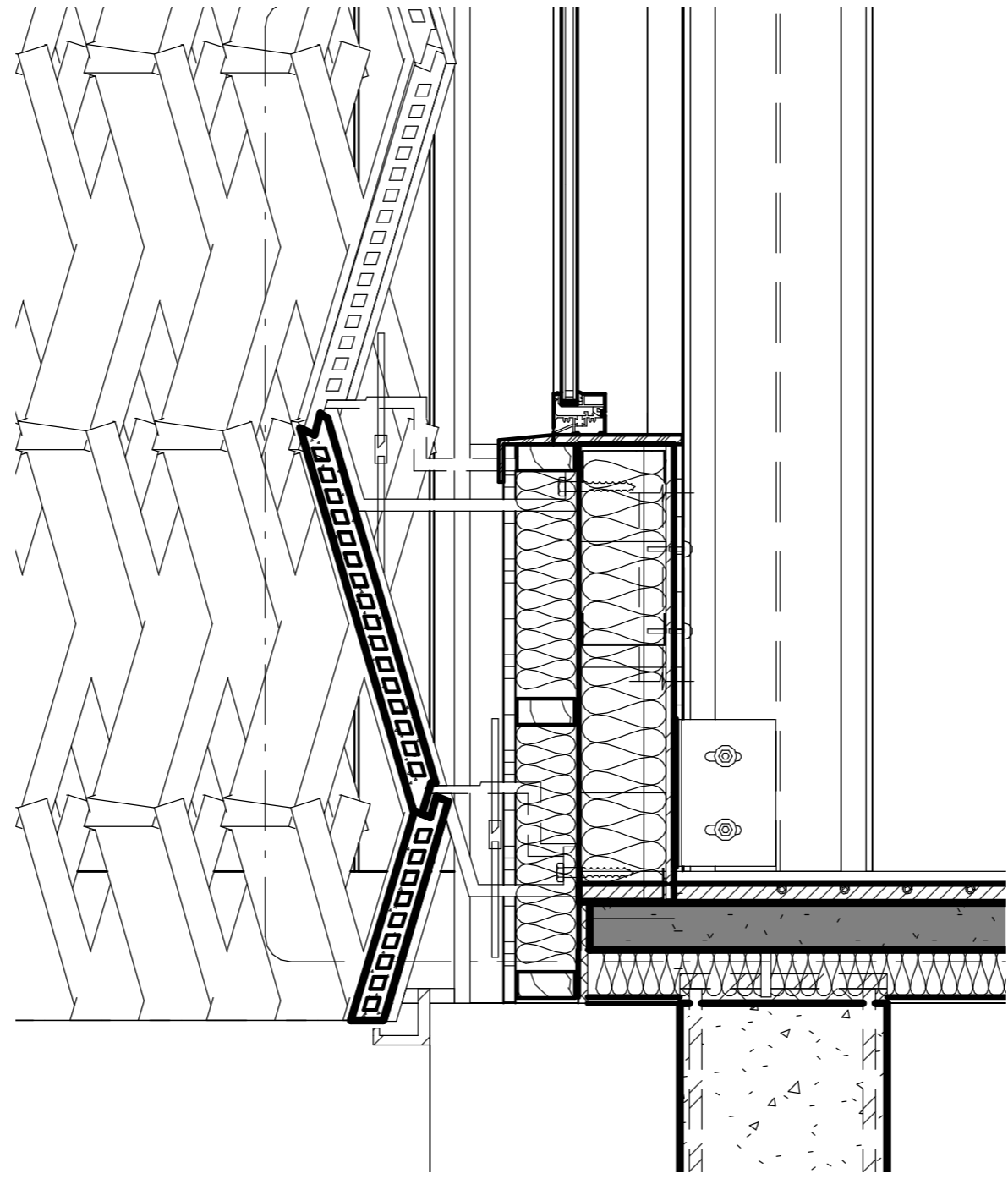



# Detail

Steel structure joint with concrete  
Prefabricated concrete Flooring with Floor heating

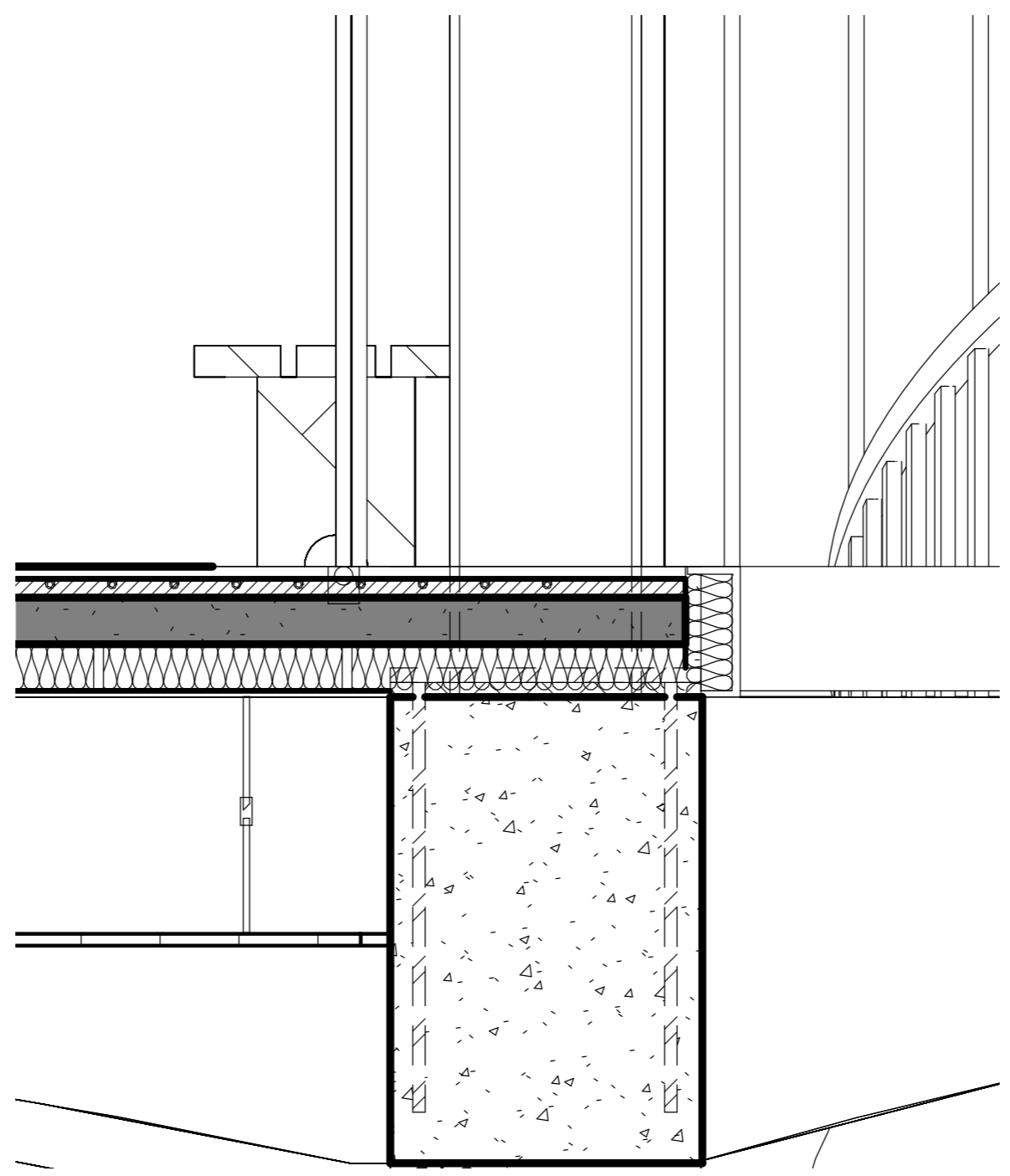

# Incubator

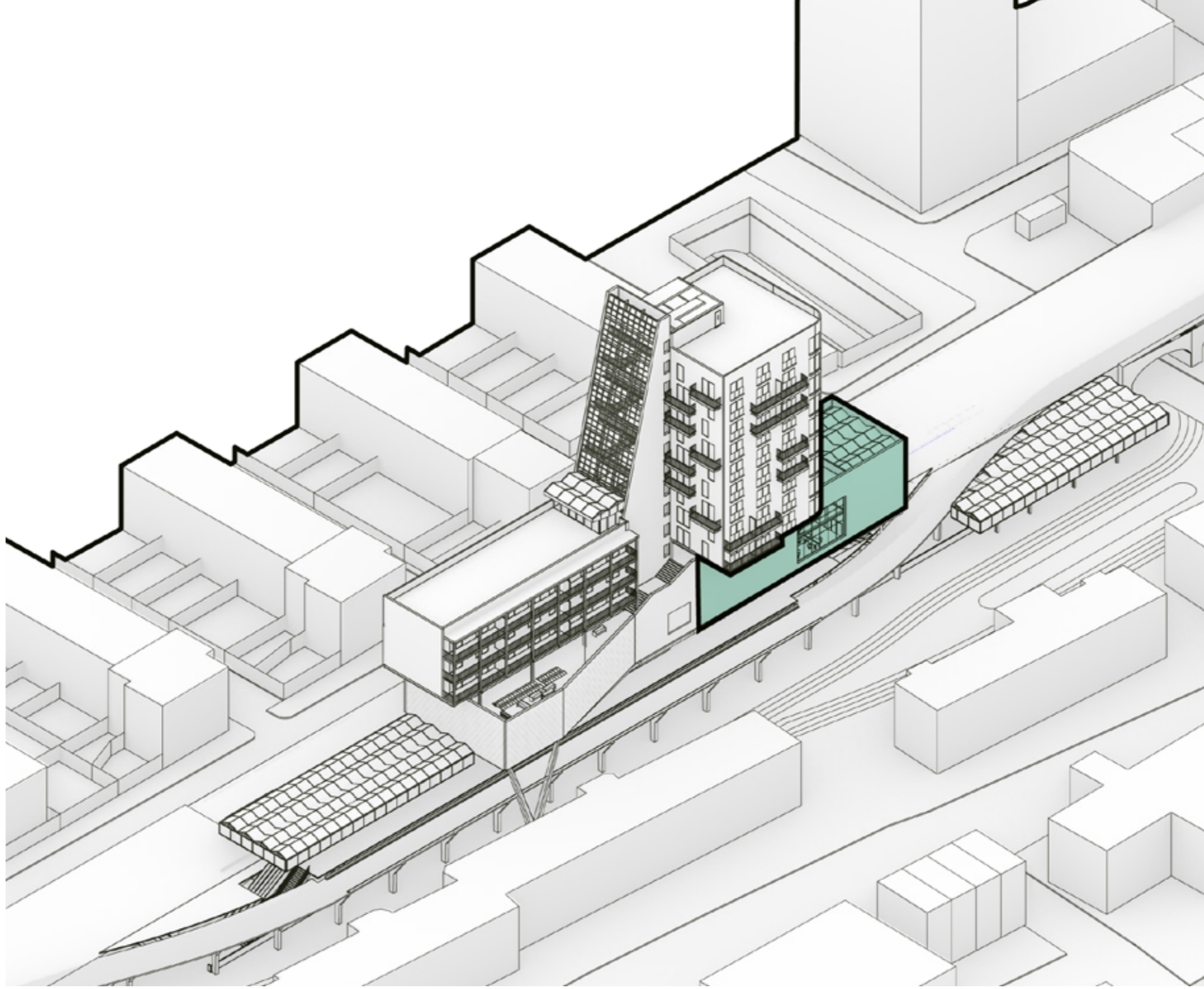



# Incubator

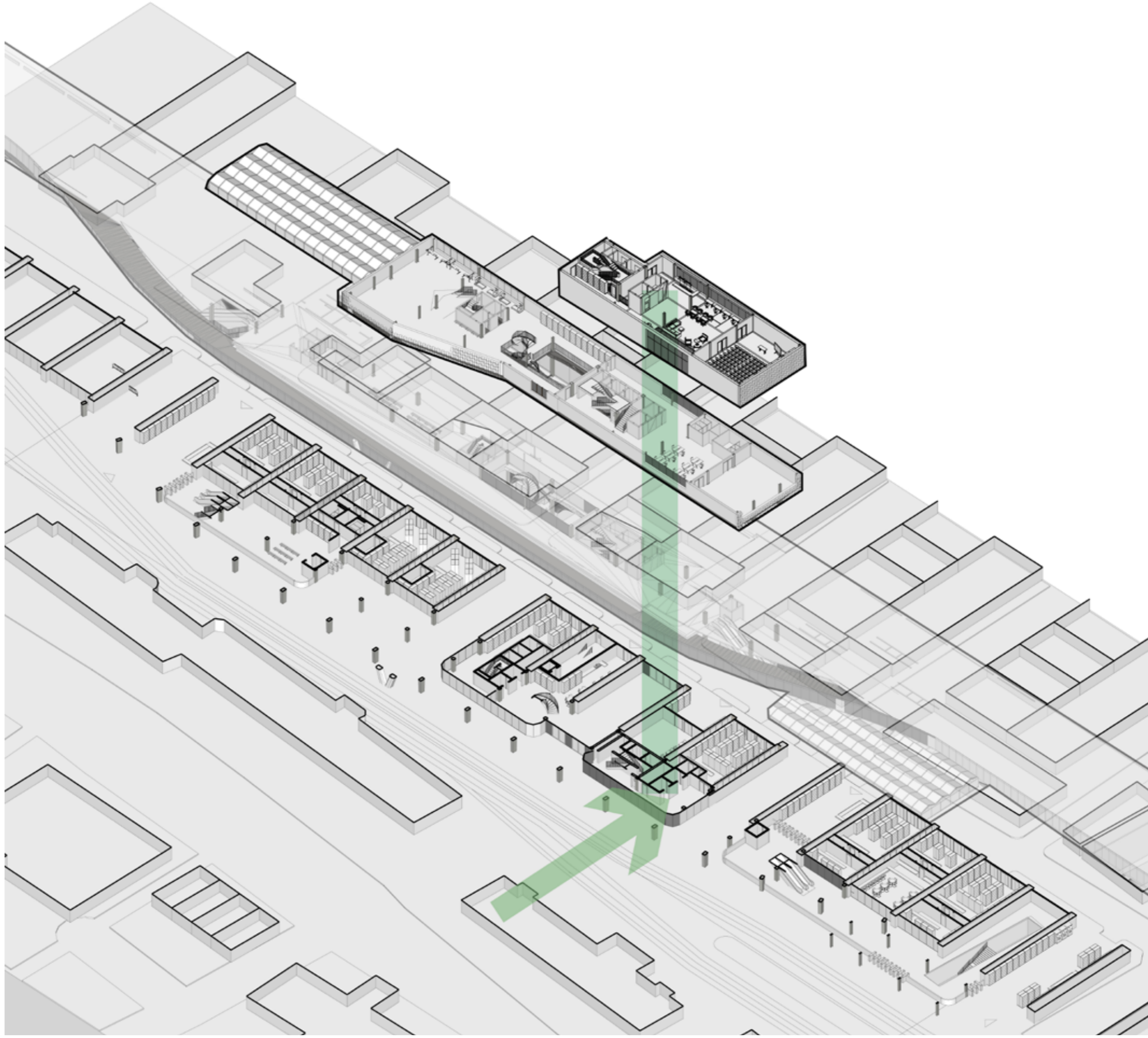

# Floor Plan

3rd Floor East  
Incubator  
Conference Space

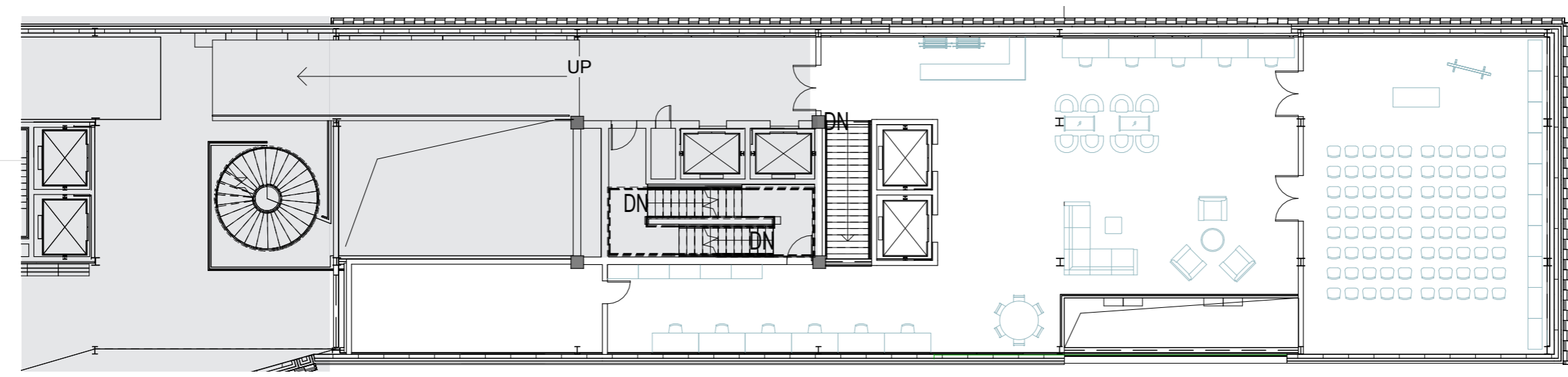

2nd Floor East  
Incubator  
Office Space and Labs

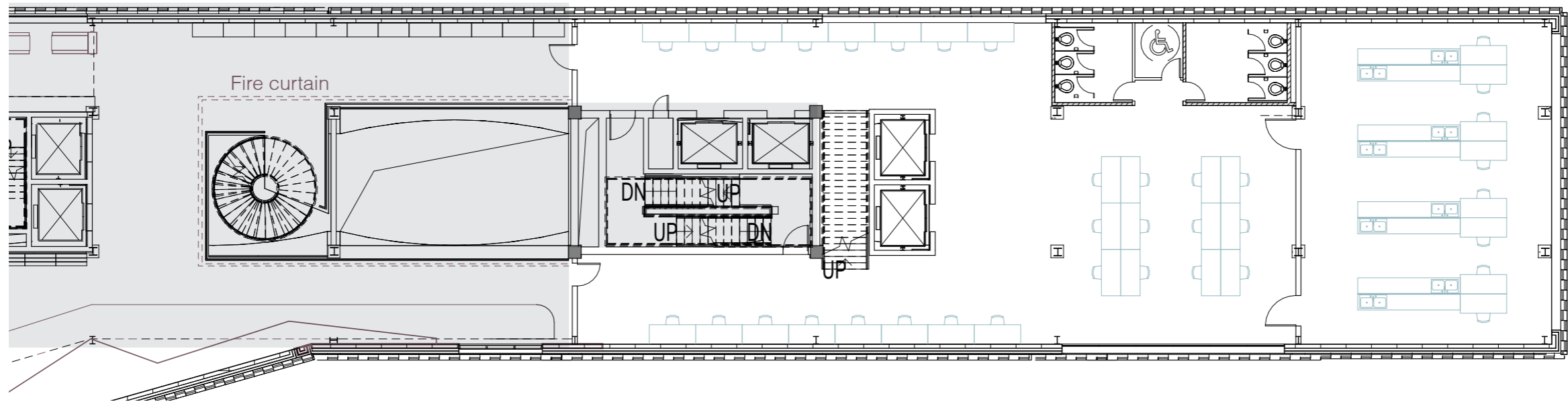

92



# Residential\_Tower Units

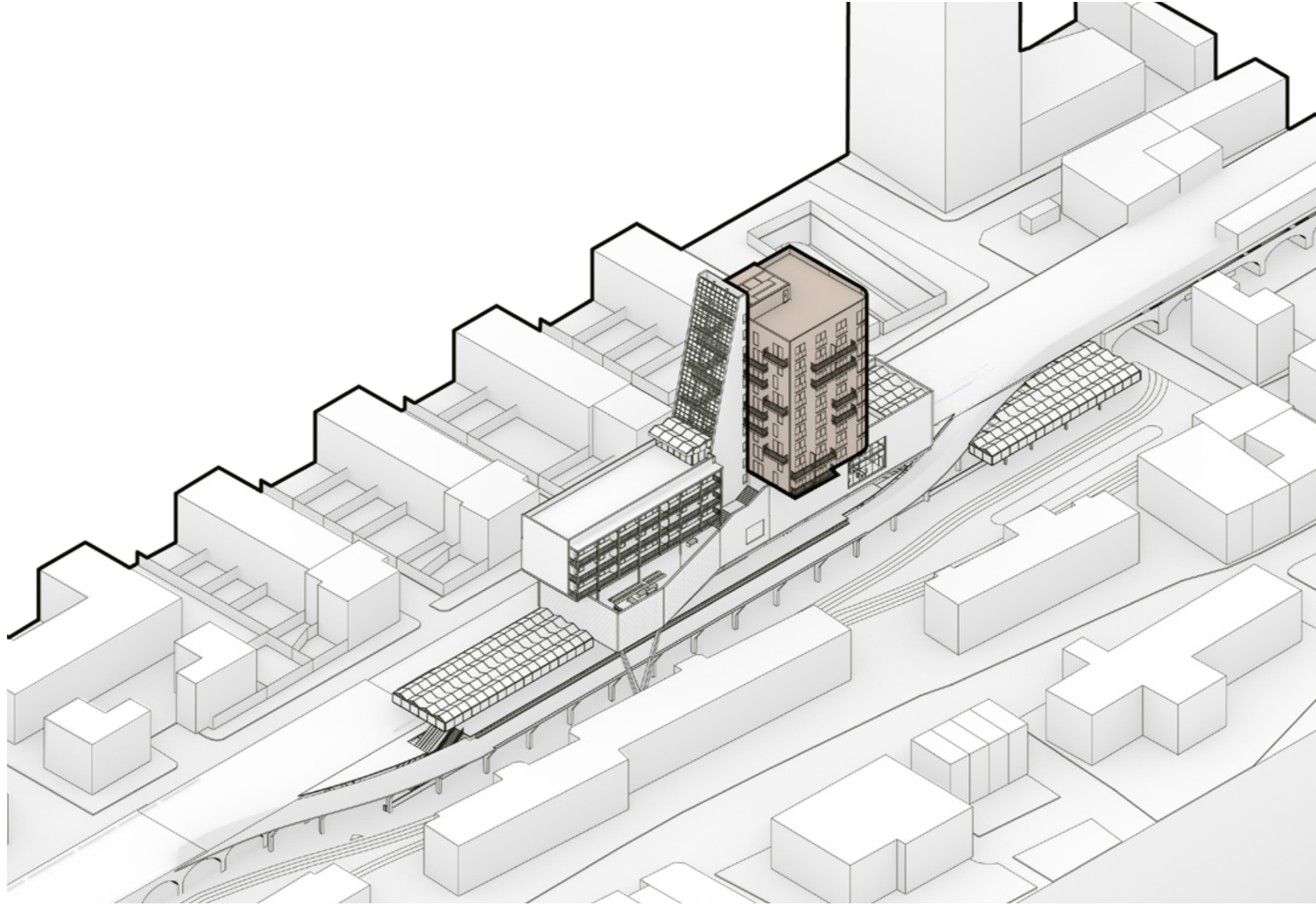

# Entrance

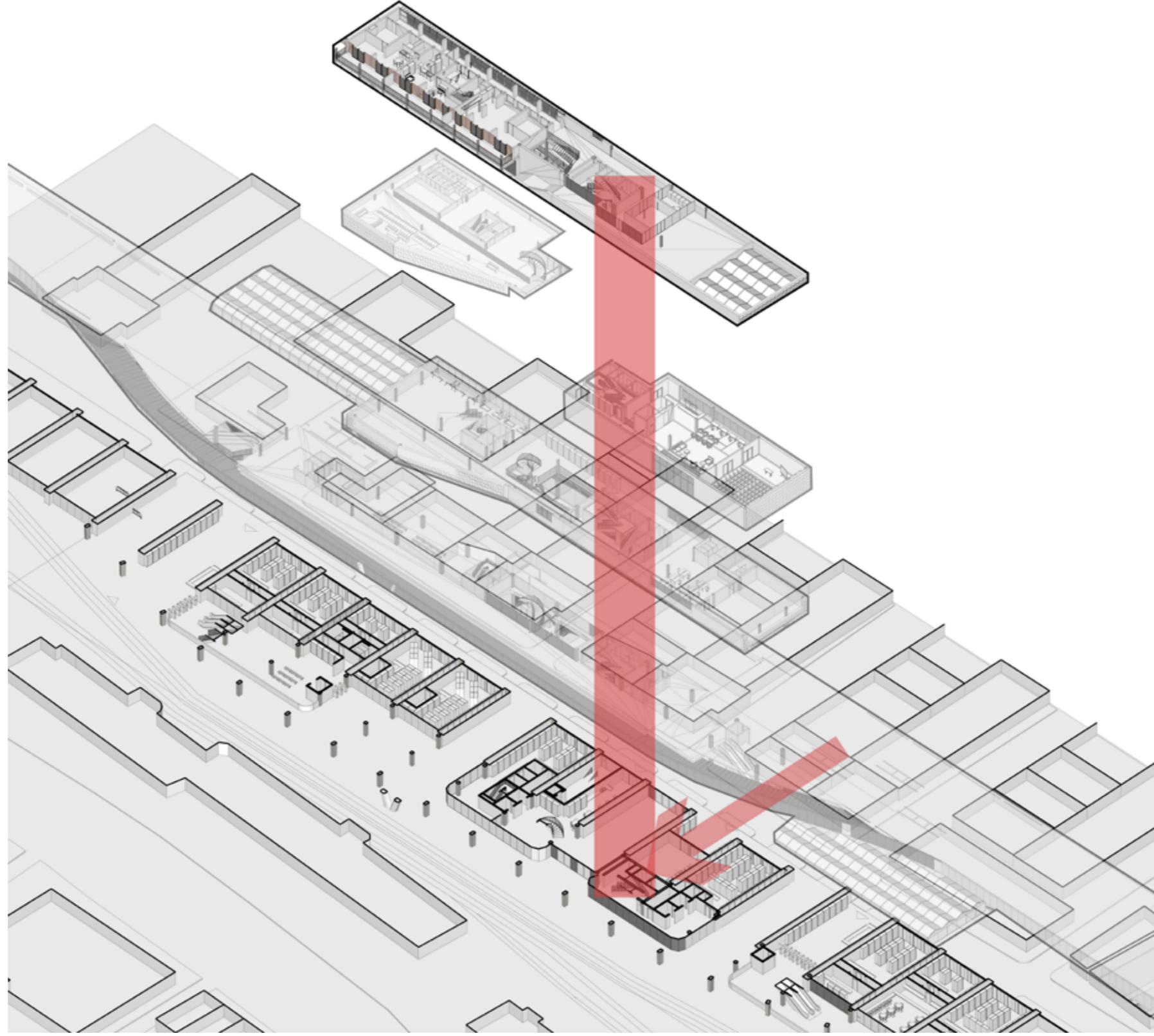



# Tower Standard Floor Plan

## Studio units

- Affordable housing
- Shared space on each floor
- Attached balcony

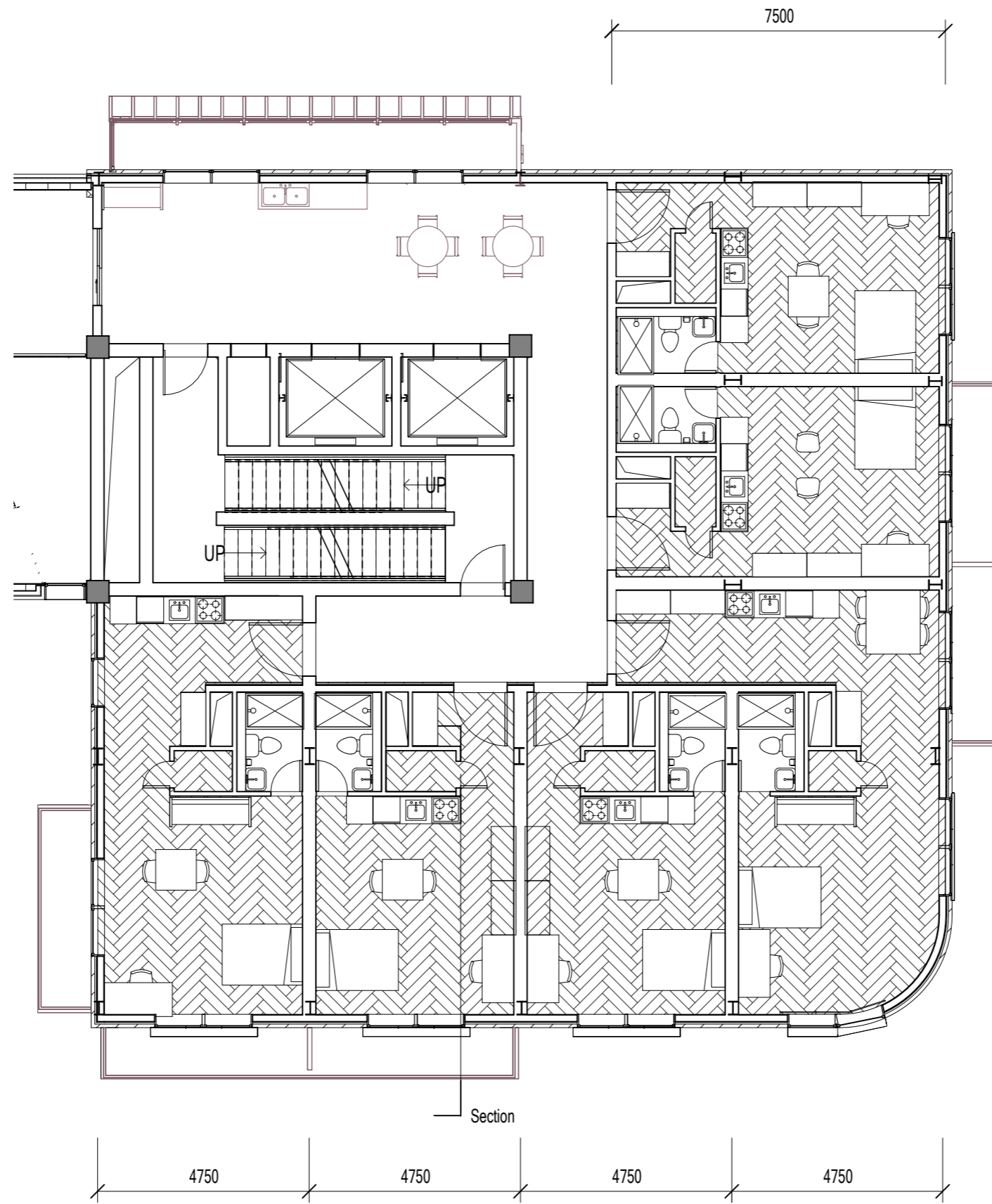

# Elevation



96

# Section

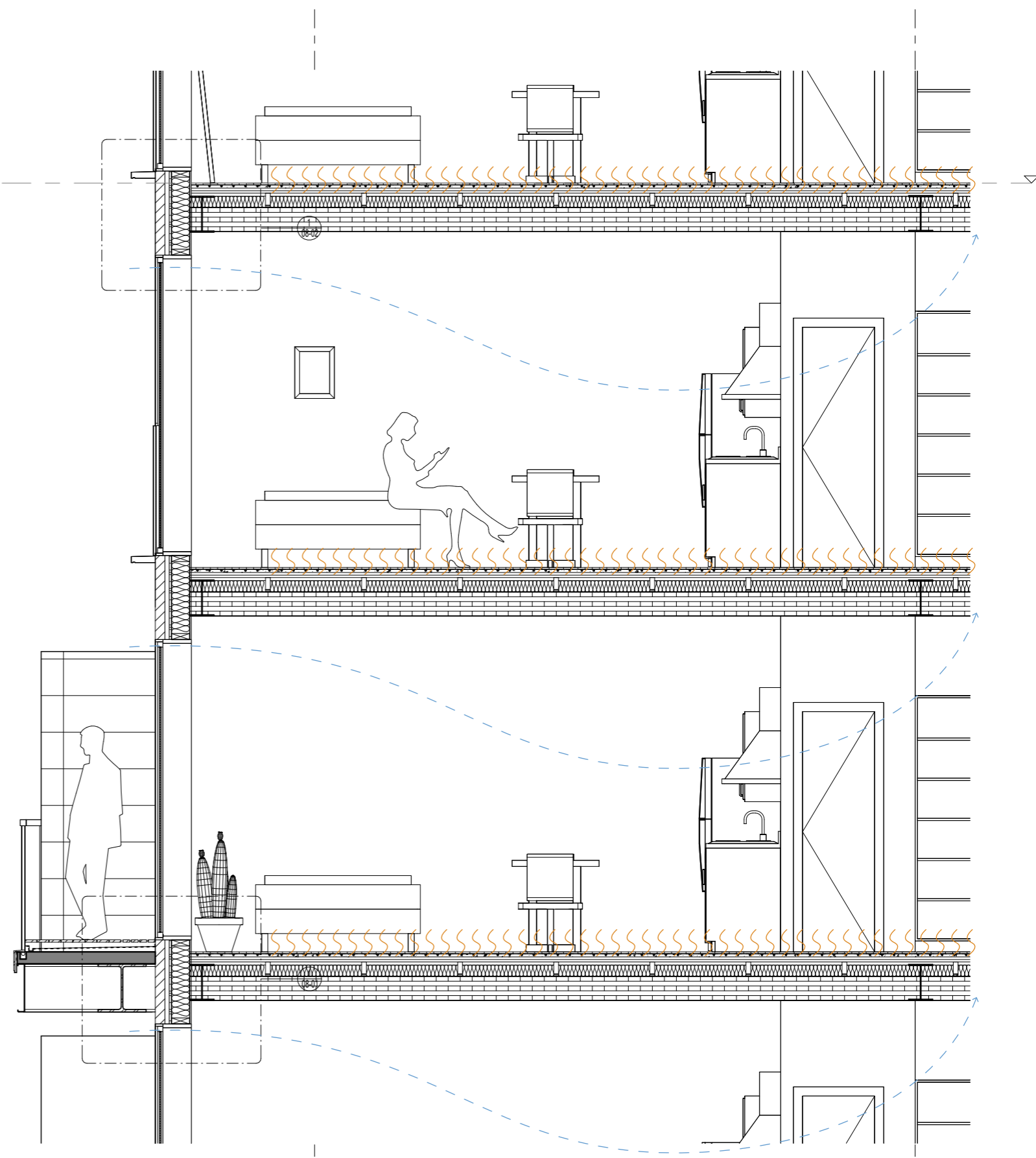



# Detail

## Floor and facade Joint

Ventilated Facade  
Floor heating  
Window seal

97

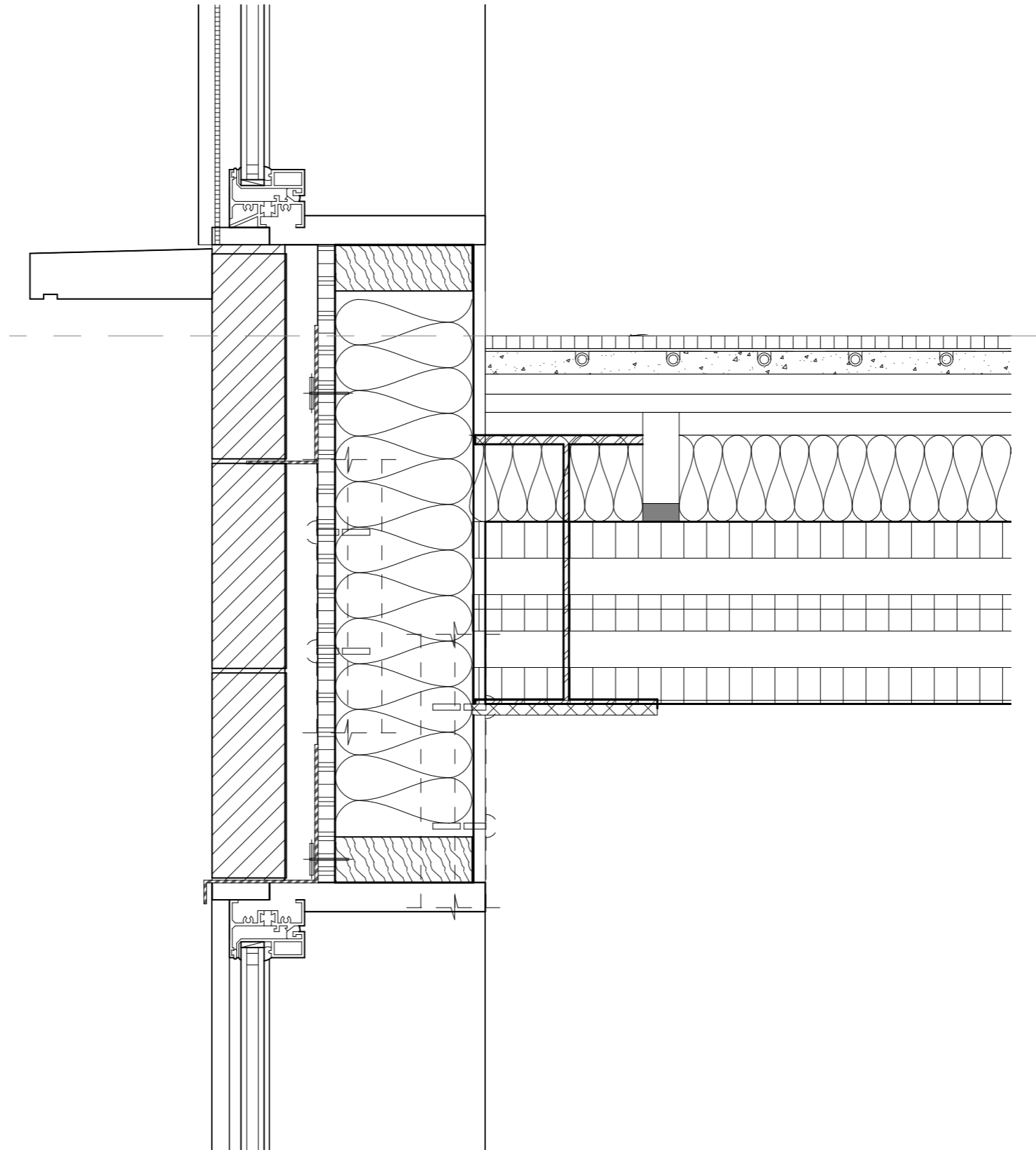

# Detail Balcony Joint

Balcony joint with main structure  
Attached directly

98

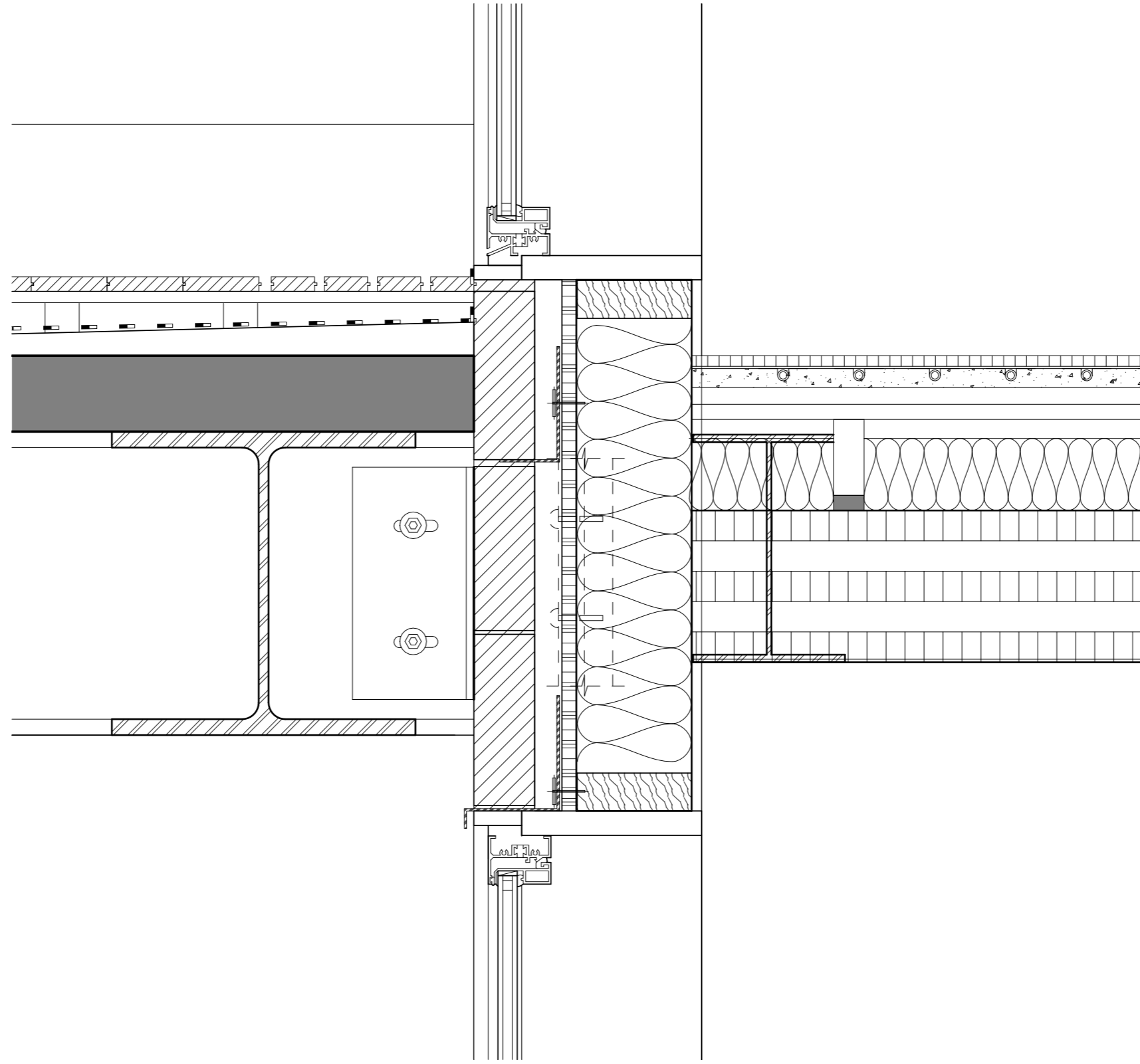



# Residential\_Gallery Units

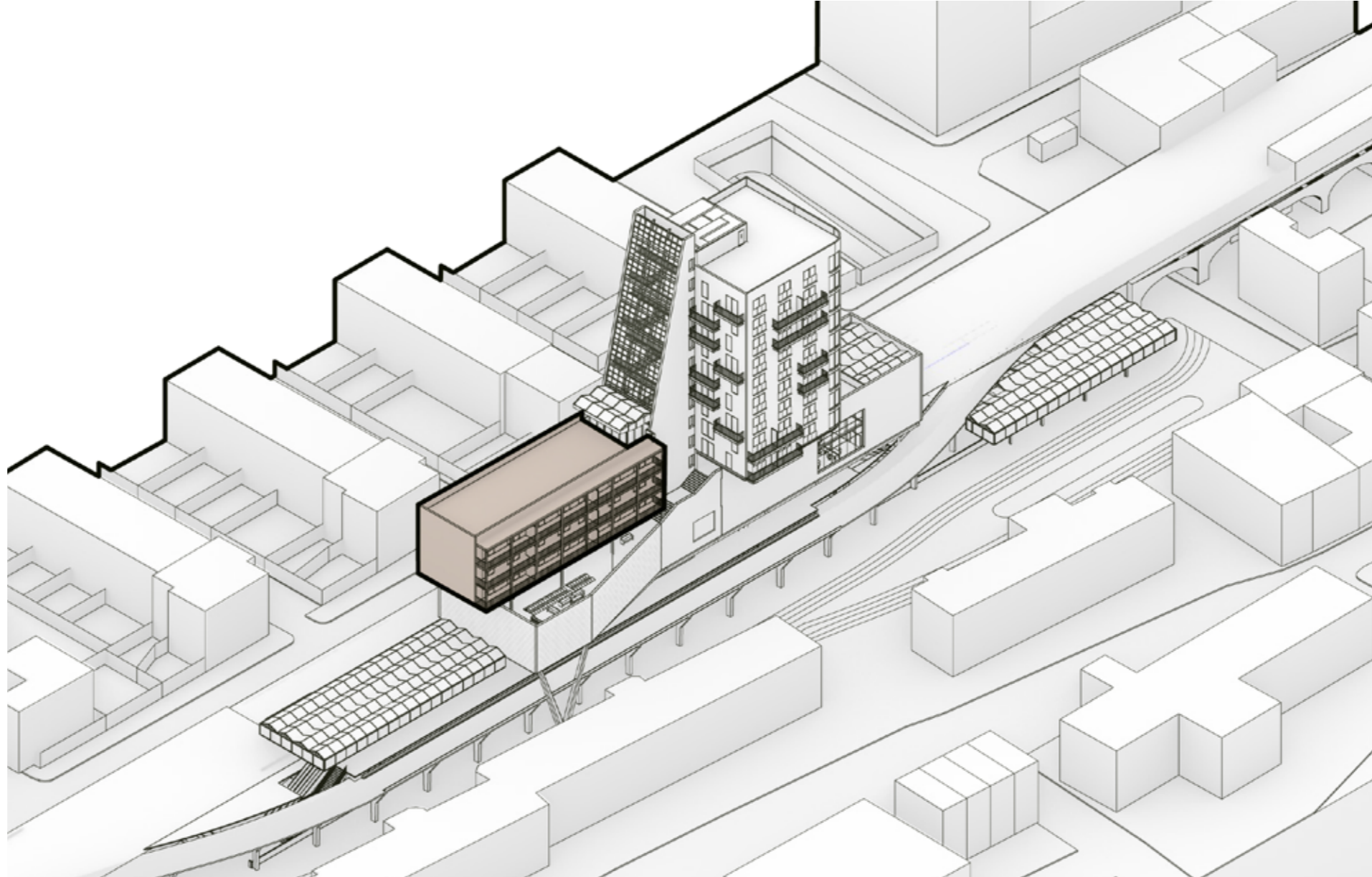

# Challenges



1, Flexibility



2, Privacy



3, Noise Pollution



Balcony

Interior

Double Facade

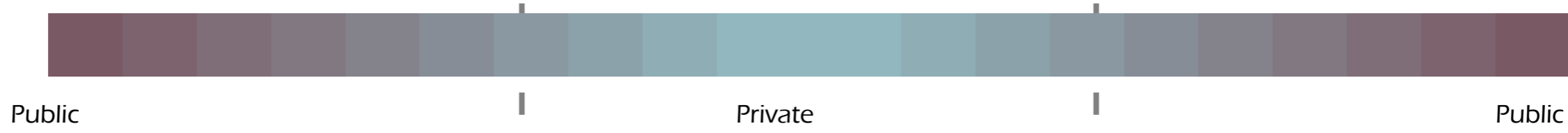

# Living

Gallery units standard floorplan  
one bedroom apartments

102

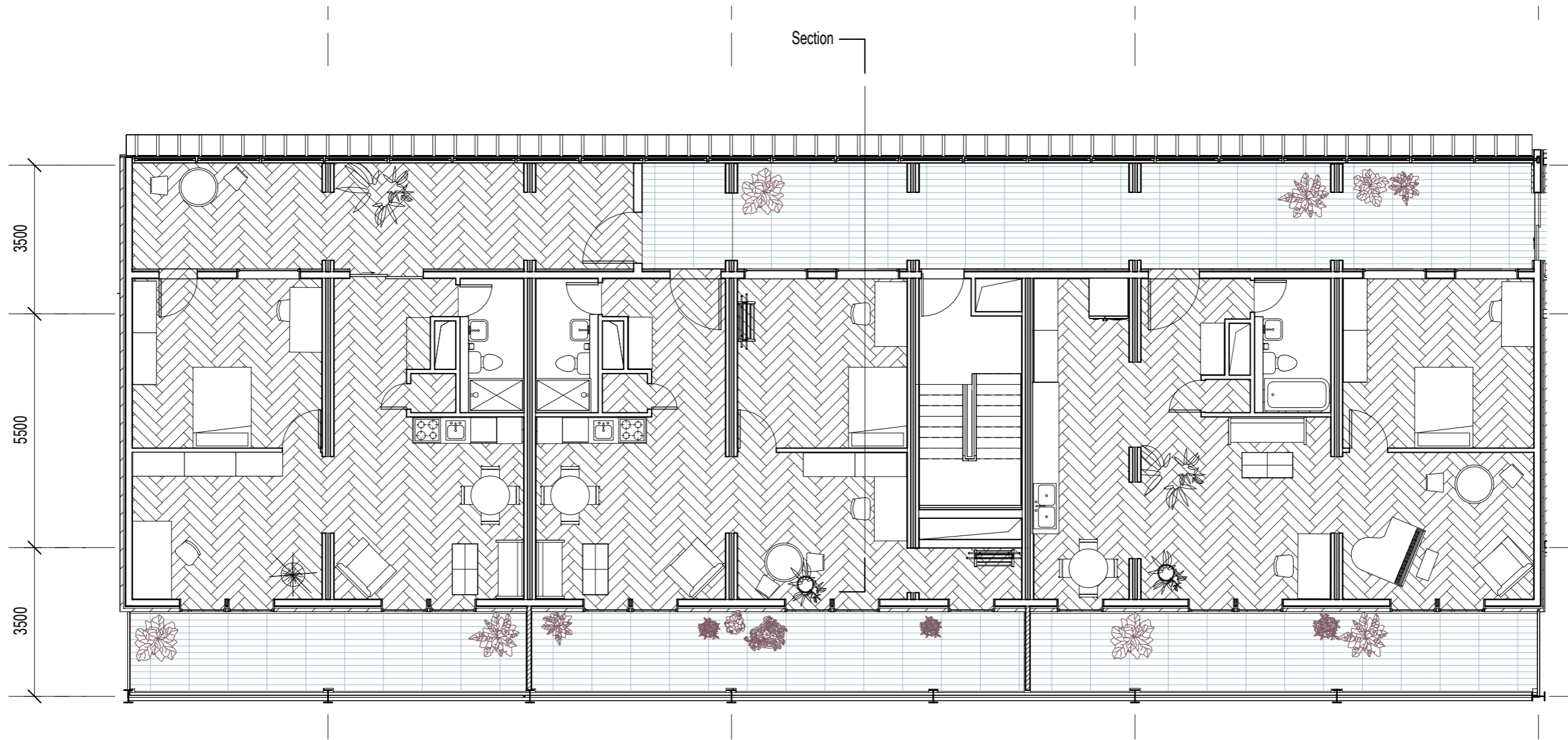



# Living

Gallery units converted floorplan  
two bedroom apartments

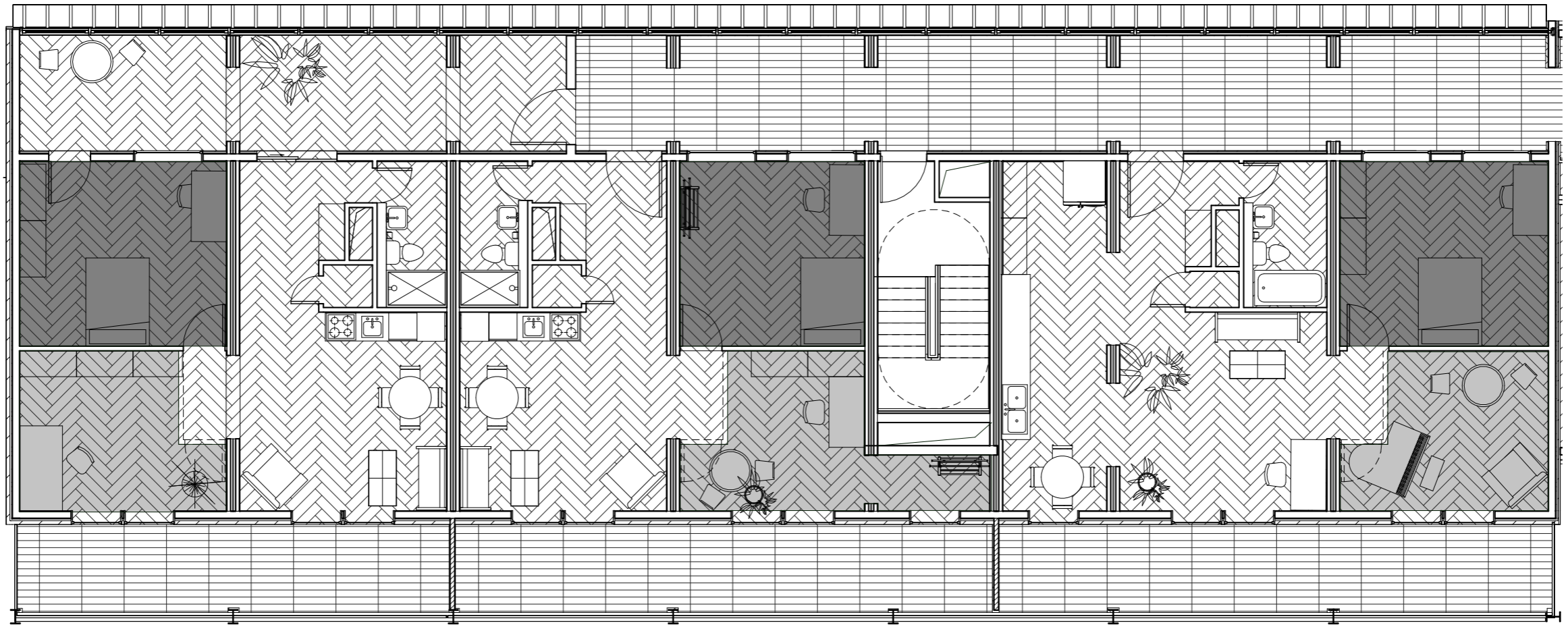

# Living

Double Facade detail plan

104

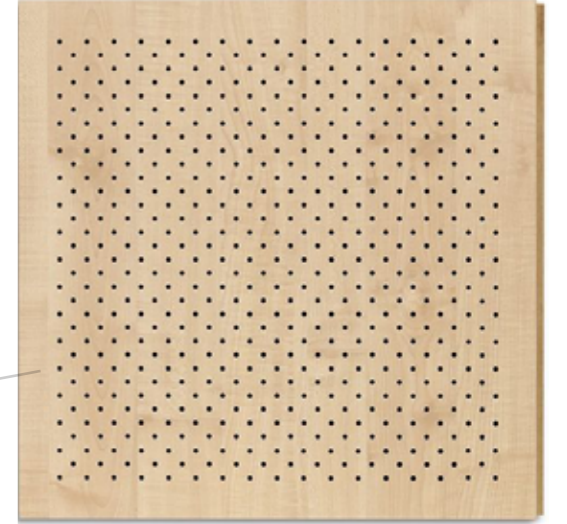
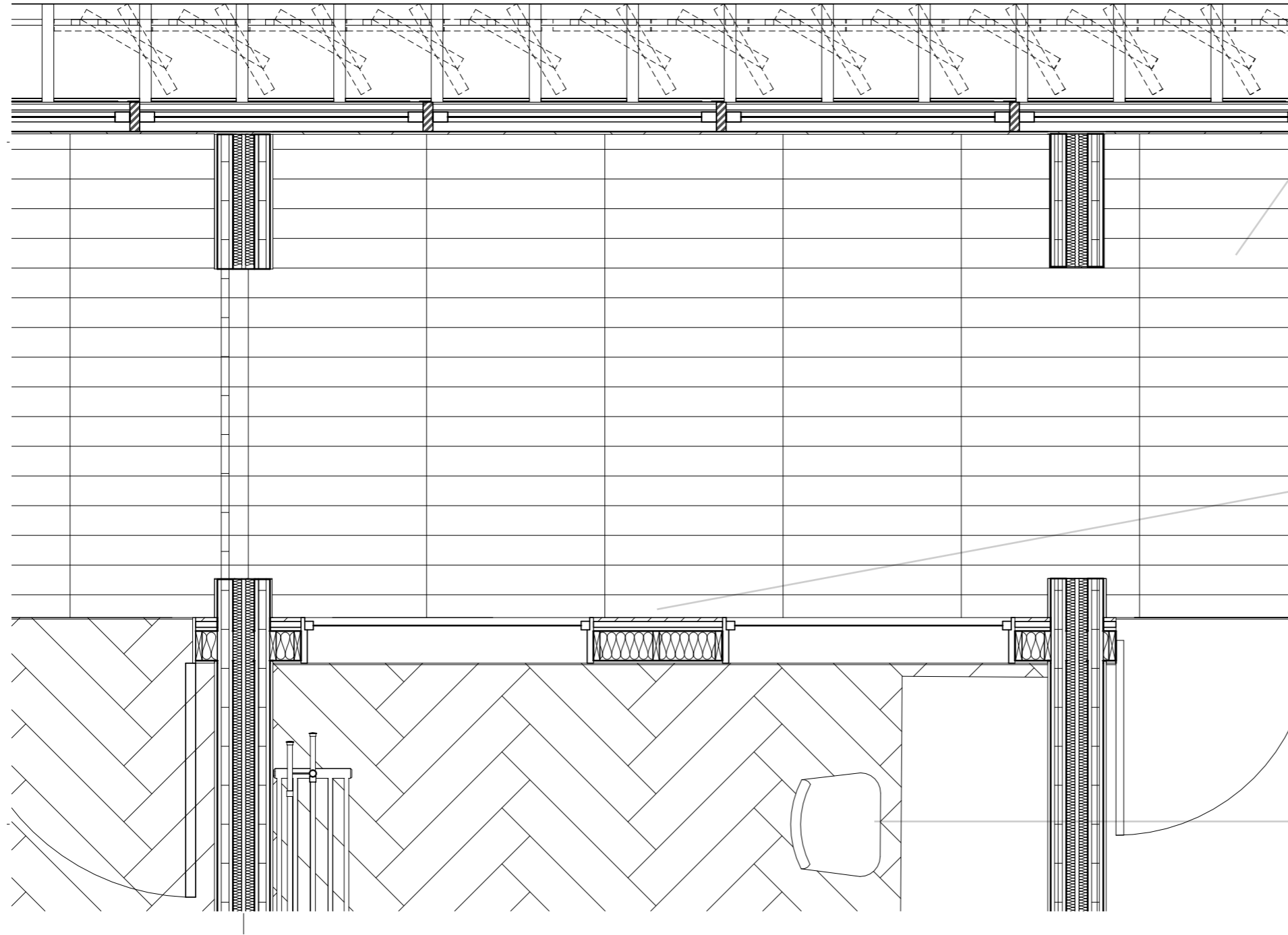



# Materiality

105

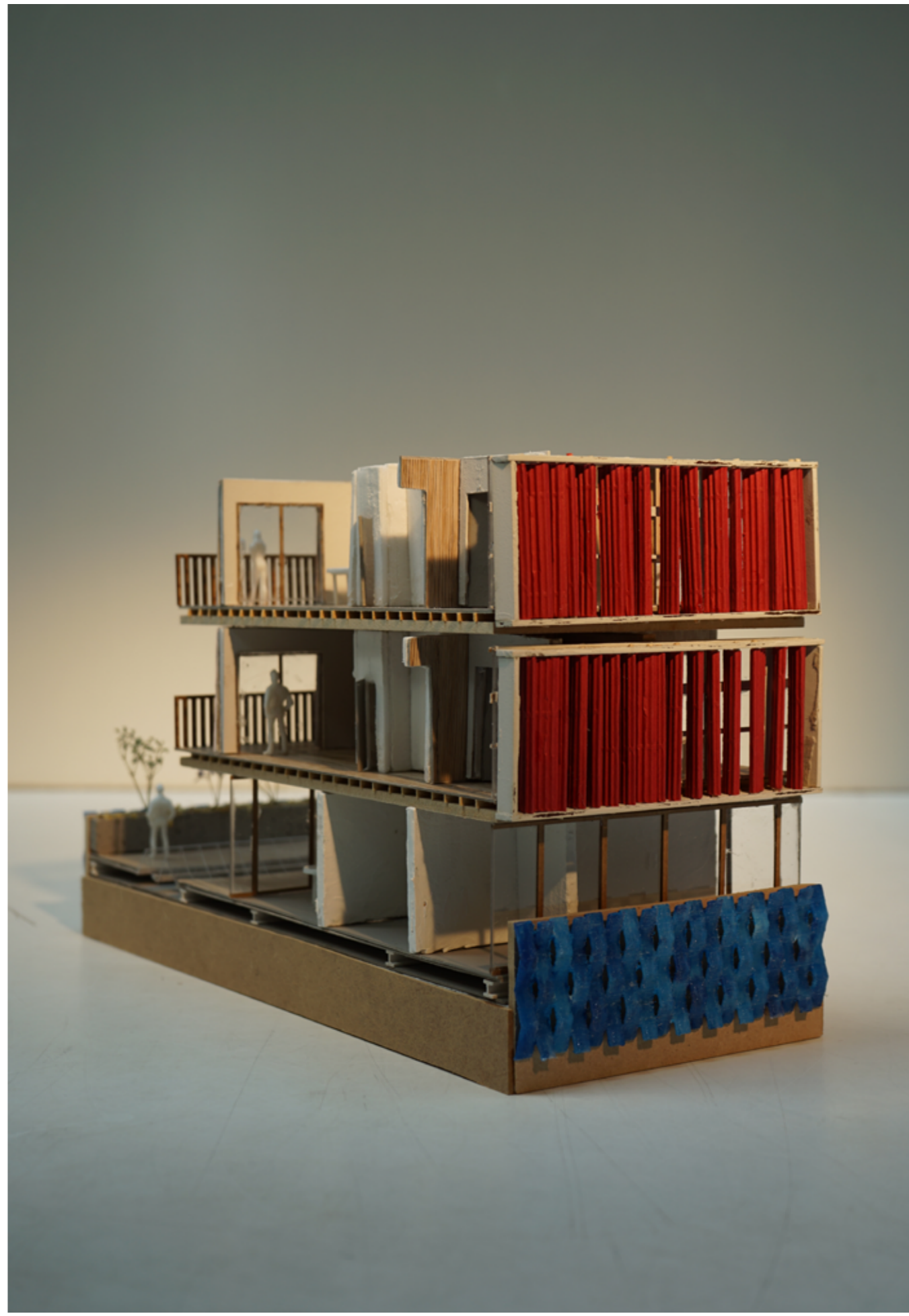



# Section

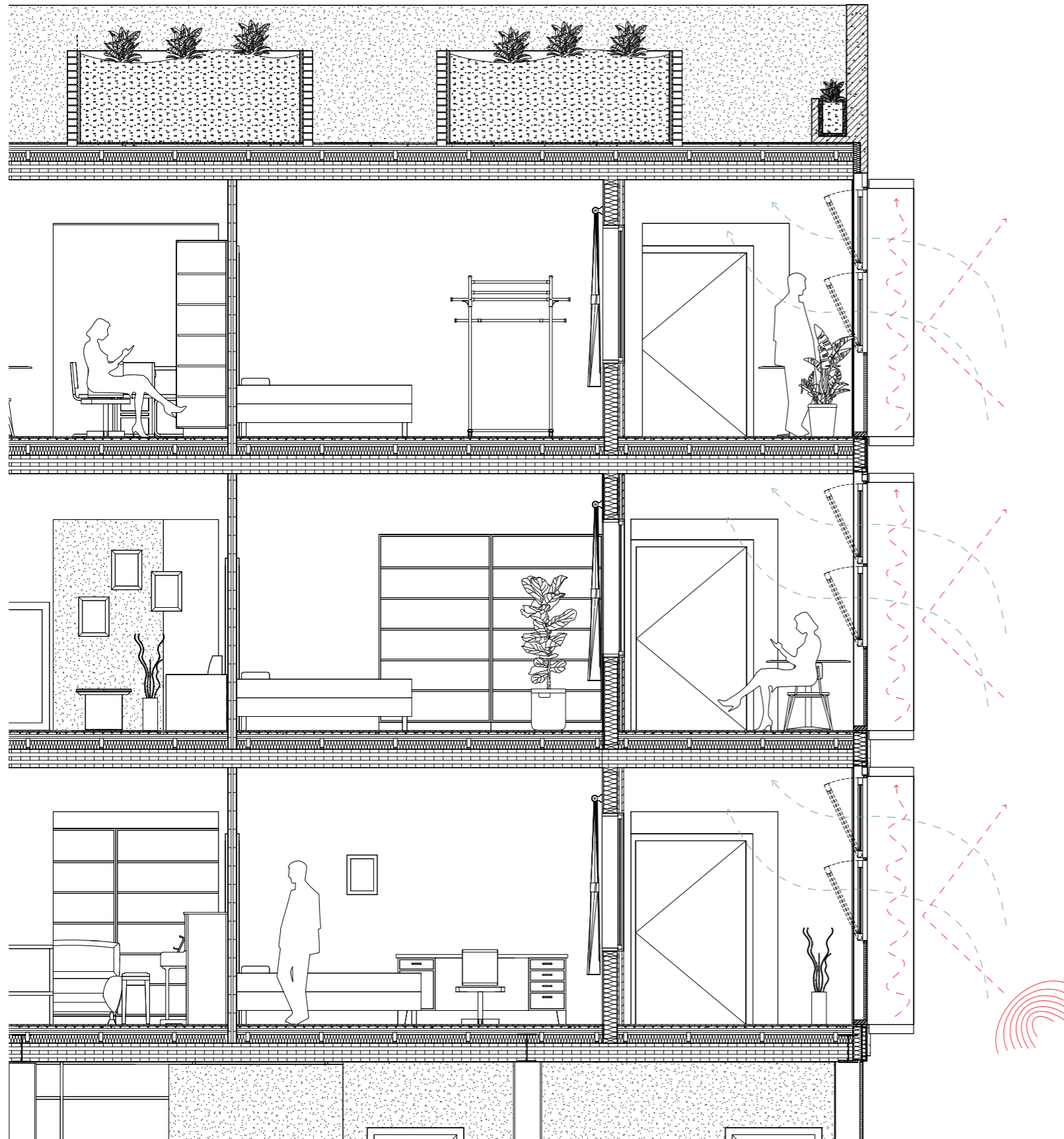

# Elevation

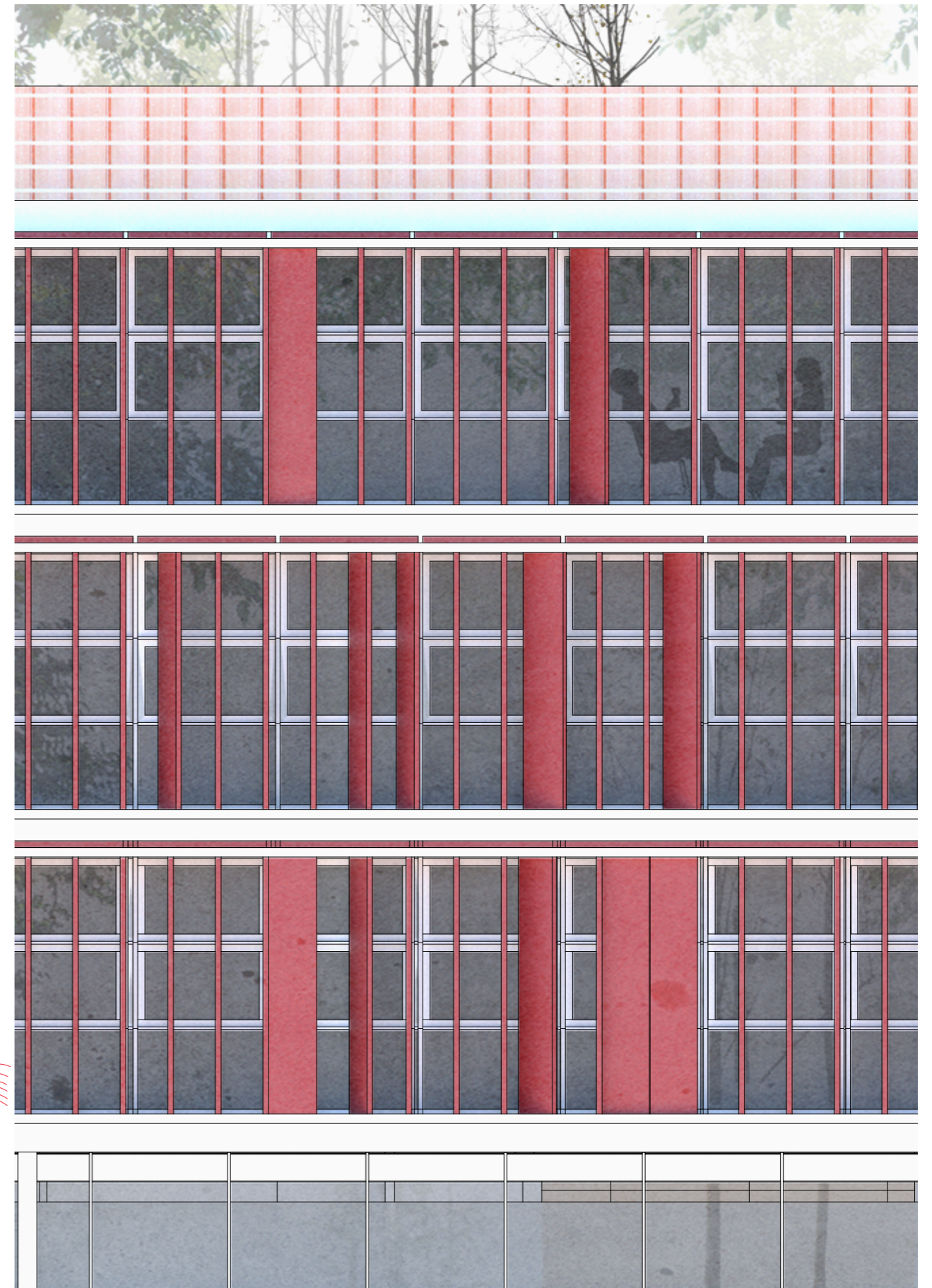



# Detail

## Hybird Stucture

Facade Panel Joint

Hybird steel and timber structure

Attached directly

107

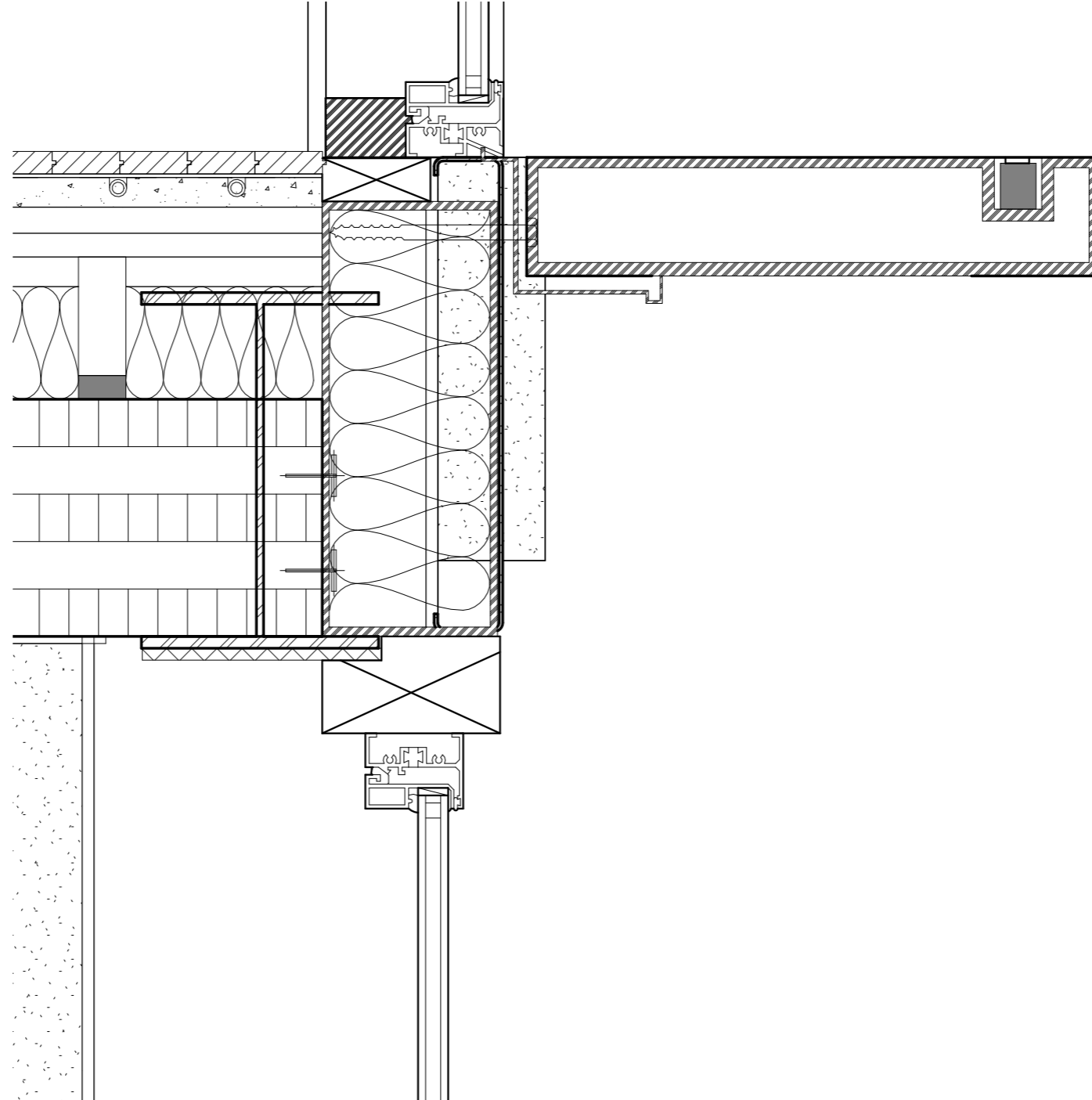

108

# Detail Section North Facade

Facade Panel joint  
CLT Flooring  
1:5

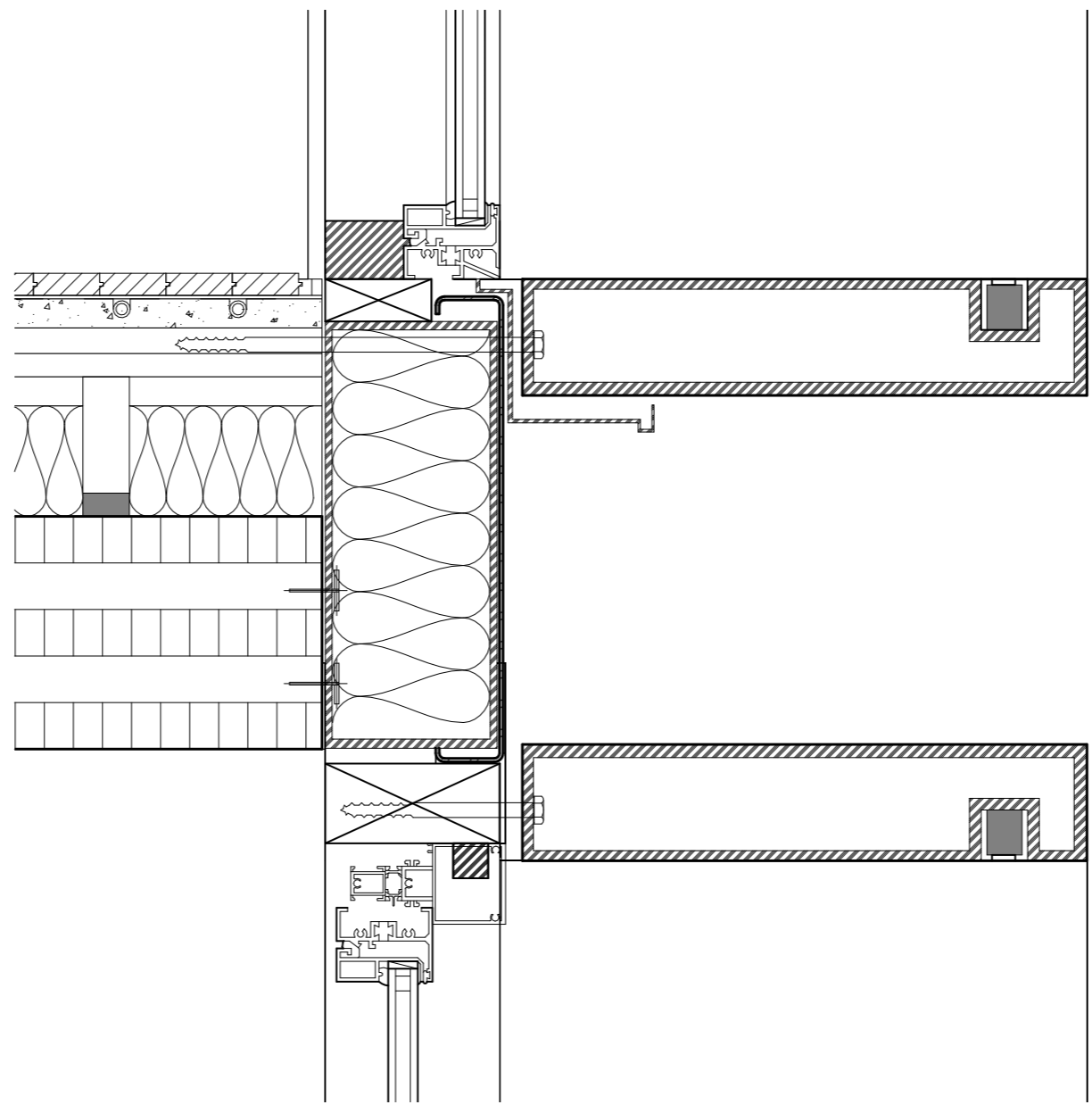



# Structure

109

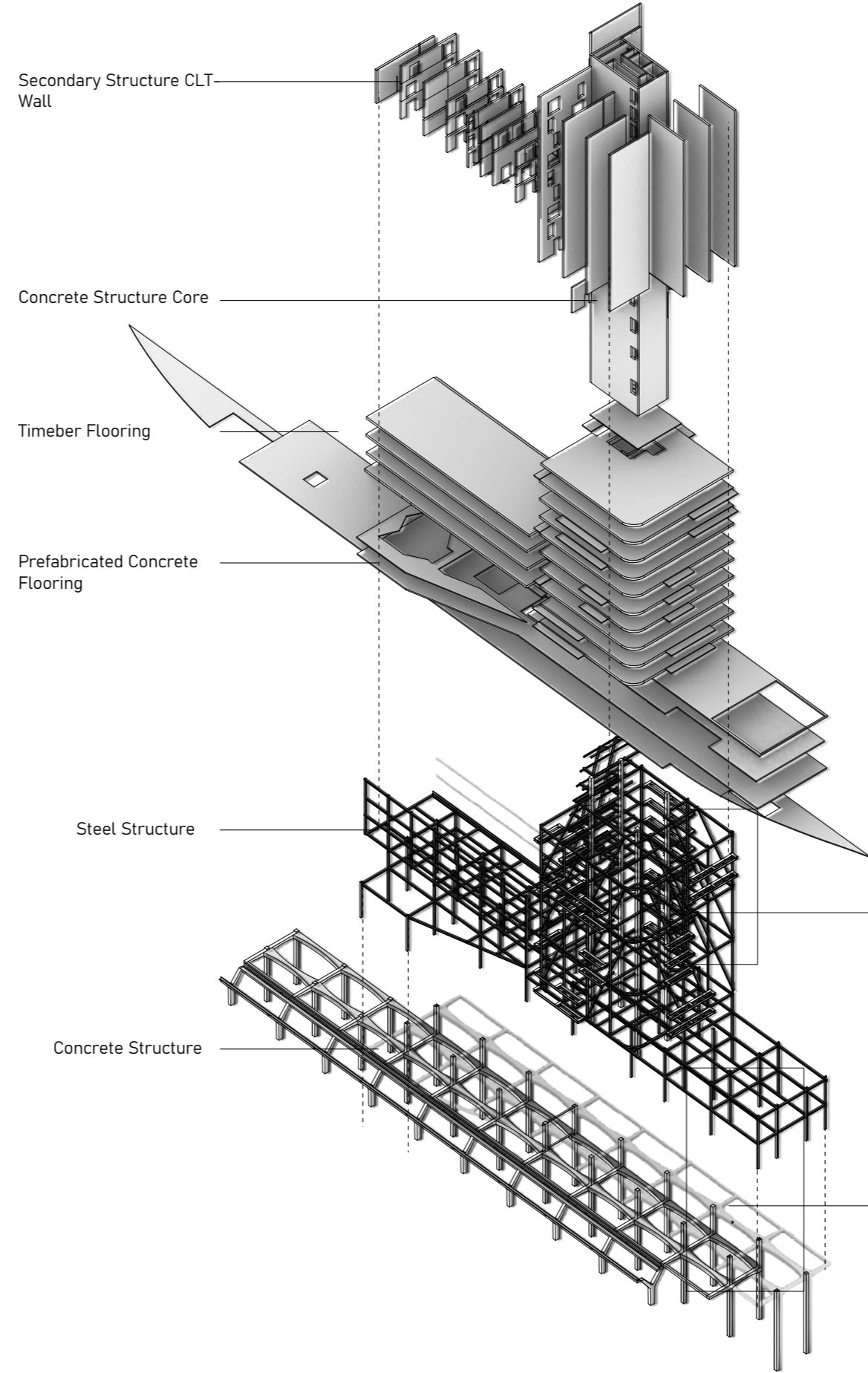

# Base Structure System

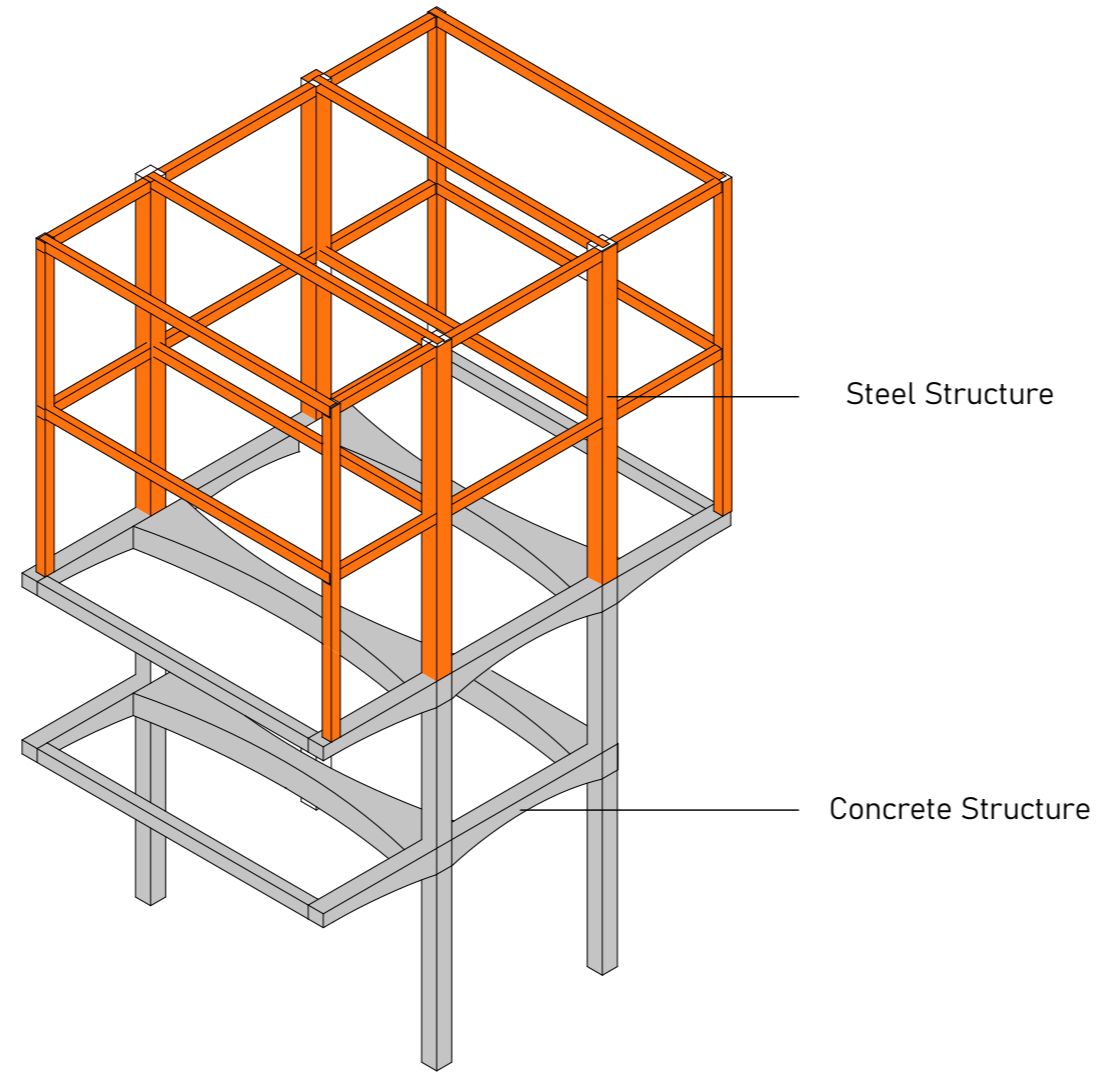



# Tower Structure System

111

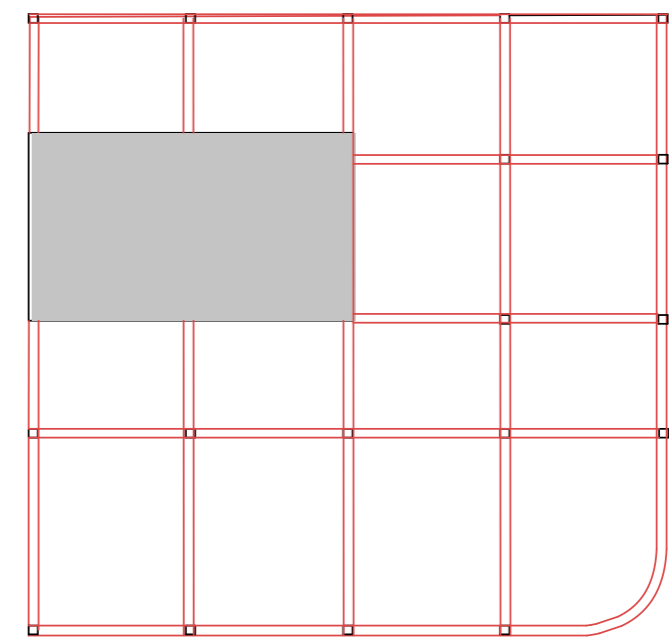
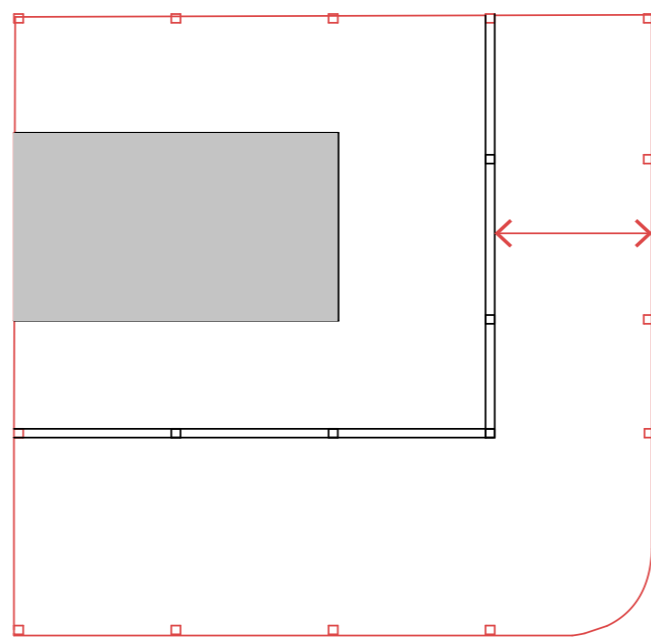
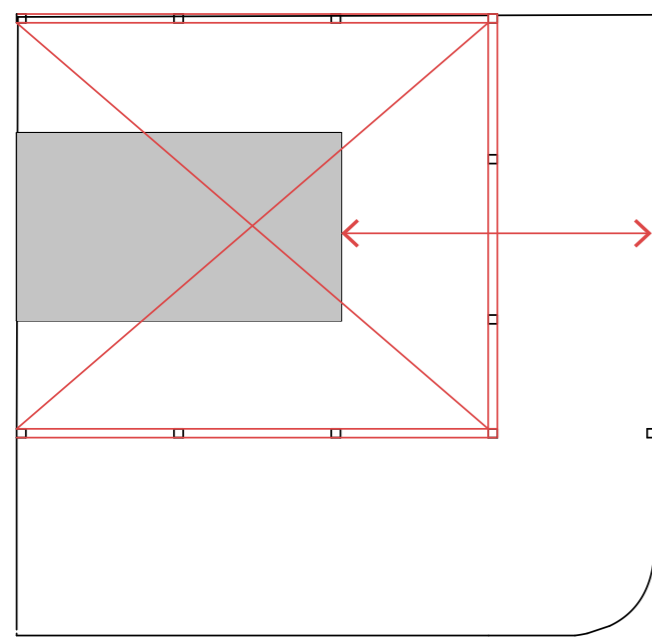

112

