

FORUM FOR THE BUILT ENVIRONMENT

FILIPA VAN DER LAAN
28 JUNE 2024
P5

TUTORS:
JORGE MEJÍA HERNÁNDEZ
FREEK SPEKSNIJDER
WILLIE VOGEL

TWO PARTS

i Background



ii Design



i Background



ii Design





CITY OF TALLINN OCTOBER 2023

PHOTOGRAPHED BY AUTHOR



E-ESTONIA

Picture taken by author



E-ESTONIA

Picture taken by author



E-ESTONIA

e-Estonia. "e-Democracy" and "Data Embassy."
e-Governance. <https://e-estonia.com/solutions/e-governance/data-embassy/>.

e-Estonia MENU

← BACK

e-Governance

In Estonia, 99% of public services are available online 24 hours a day. E-services are only impossible for divorces — you still need to leave the house for this.

Thanks to a safe, convenient, and flexible digital ecosystem, Estonia has reached an unprecedented level of transparency in governance and built broad trust in its digital society. As a result, Estonia saves over 1400 years of working time annually and has become a hassle-free environment for business and entrepreneurship.



Government Cloud

- Data Embassy
- e-Democracy & open data**
- Justice & public safety
- e-Services & registries

e-Democracy & open data

Internet voting (i-Voting) is a unique solution that conveniently engages citizens in the governance process. This system allows voters to cast their ballots from any internet-connected computer anywhere in the world. During a designated pre-voting period, the voter logs into the system using their government-issued e-ID and casts a ballot. The voter's identity is removed from the ballot before it reaches the National Electoral Commission for counting, thereby ensuring anonymity.

Since 2017, 16- and 17-year-old citizens have been eligible to vote in local elections. And historically, no less than 36% — and sometimes nearly 64% — of eligible voters participate in the i-Voting system.

e-Democracy supports and enhances democratic processes and institutions through this technology. It offers citizens the opportunity to participate in the political process as a vital part of the development of e-Governance.

46,7%
Estonians use i-Voting

since 2005
Estonia uses i-Voting

#5
The Open Data Maturity Report

Government Cloud

- Data Embassy**
- e-Democracy & open data
- Justice & public safety
- e-Services & registries

Data Embassy

Data Embassy is an extension in the cloud of the Estonian government, which means the state owns server resources outside its territorial boundaries. This is an innovative concept for handling state information, since states usually store their information within their physical boundaries. Data Embassy resources are under Estonian state control, secured against cyberattacks or crisis situations with KSI Blockchain technology, and are capable not only providing data backups, but also operating the most critical services.

When we say "data embassy", we mean a data centre. It is located in Luxembourg under a Tier 4 level of security — the highest level for data facilities. It is not an embassy in the traditional diplomatic sense and while the founding agreement does take into account the Vienna Convention on Diplomatic Relations, it is something completely new under international law. It is fully under the control of Estonia, but has the same rights as physical embassies such as immunity.

Luxembourg is the first data embassy location because of the high quality technical capacity, but also because of their openness to work with this new concept. In this collaboration, Luxembourg and Estonia are pathfinders in creating a unique and innovative way to ensure digital continuity in the world.

The Data Embassy kick-off took place in 2015 and the finalised agreement between Estonia and Luxembourg was signed in 2017. The development of the Estonian Government Cloud is a collaboration between the Estonian Government and private sector companies, including Cybernetica, Dell EMC, Ericsson, OpenNode, and Tella.

#1
data embassy in Luxembourg

E-ESTONIA

e-Estonia. "e-Democracy" and "Data Embassy."
e-Governance. <https://e-estonia.com/solutions/e-governance/data-embassy/>.

e-Estonia MENU

← BACK

e-Governance

In Estonia, 99% of public services are available online 24 hours a day. E-services are only impossible for divorces — you still need to leave the house for this.

Thanks to a safe, convenient, and flexible digital ecosystem, Estonia has achieved an unprecedented level of transparency in governance and a result, Estonia saves over 1400 years of working time annually, creating a more favorable environment for business and entrepreneurship.

e-Governance

In Estonia, 99% of public services are available online 24 hours a day. E-services are only impossible for divorces — you still need to leave the house for this.



- Government Cloud
- Data Embassy
- e-Democracy & open data**
- Justice & public safety
- e-Services & registries

e-Democracy & open data

Internet voting (i-Voting) is a unique solution that conveniently engages citizens in the governance process. This system allows voters to cast their ballots from any internet-connected computer anywhere in the world. During a designated pre-voting period, the voter logs into the system using their government-issued e-ID and casts a ballot. The voter's identity is removed from the ballot before it reaches the National Electoral Commission for counting, thereby ensuring anonymity.

Since 2017, 16- and 17-year-old citizens have been eligible to vote in local elections. And historically, no less than 36% — and sometimes nearly 64% — of eligible voters participate in the i-Voting system.

e-Democracy supports and enhances democratic processes and institutions through this technology. It offers citizens the opportunity to participate in the political process as a vital part of the development of e-Governance.

46,7%
Estonians use i-Voting

since 2005
Estonia uses i-Voting

#5
The Open Data Maturity Report

- Government Cloud
- Data Embassy**
- e-Democracy & open data
- Justice & public safety
- e-Services & registries

Data Embassy

Data Embassy is an extension in the cloud of the Estonian government, which means the state owns server resources outside its territorial boundaries. This is an innovative concept for handling state information, since states usually store their information within their physical boundaries. Data Embassy resources are under Estonian state control, secured against cyberattacks or crisis situations with KSI Blockchain technology, and are capable not only providing data backups, but also operating the most critical services.

When we say "data embassy", we mean a data centre. It is located in Luxembourg under a Tier 4 level of security — the highest level for data facilities. It is not an embassy in the traditional diplomatic sense and while the founding agreement does take into account the Vienna Convention on Diplomatic Relations, it is something completely new under international law. It is fully under the control of Estonia, but has the same rights as physical embassies such as immunity.

Luxembourg is the first data embassy location because of the high quality technical capacity, but also because of their openness to work with this new concept. In this collaboration, Luxembourg and Estonia are pathfinders in creating a unique and innovative way to ensure digital continuity in the world.

The Data Embassy kick-off took place in 2015 and the finalised agreement between Estonia and Luxembourg was signed in 2017. The development of the Estonian Government Cloud is a collaboration between the Estonian Government and private sector companies, including Cybernetica, Dell EMC, Ericsson, OpenNode, and Tella.

#1
data embassy in Luxembourg

INDEPENDENCE 1991

PHOTOGRAPHER UNKNOWN



HUNDREDS OF THOUSANDS DEMANDED FREEDOM AND INDEPENDENCE FOR ESTONIA. EVENT LATER CALLED THE SINGING REVOLUTION, LOCATED ON THE TALLINN SONG FESTIVAL GROUNDS. 11 SEPTEMBER 1988.

E-ESTONIA

ILLUSTRATION BY EIKO OJALA



FASCINATION

esti Riigiarhiivi Filiaali (Parteiarhiivi)
fotokolleksioon (AIS). 1980s. Retrieved from
AIS, "ERAF.2.2.3762.1 (AIS)"



SERVICE HALL IN MUSTAMÄE, TALLINN IN THE 1980S

FASCINATION

esti Riigiarhiivi Filiaali (Parteiarhiivi)
fotokolleksioon (AIS). 1980s. Retrieved from
AIS, "ERAF.2.2.3762.1 (AIS)"



SERVICE HALL IN MUSTAMÄE, TALLINN IN THE 1980S

WHAT HAS HAPPENED WITH THE PHYSICAL PUBLIC SERVICE IN ESTONIA?

FASCINATION

Former Tallinn Town Hall, 13th century



FASCINATION

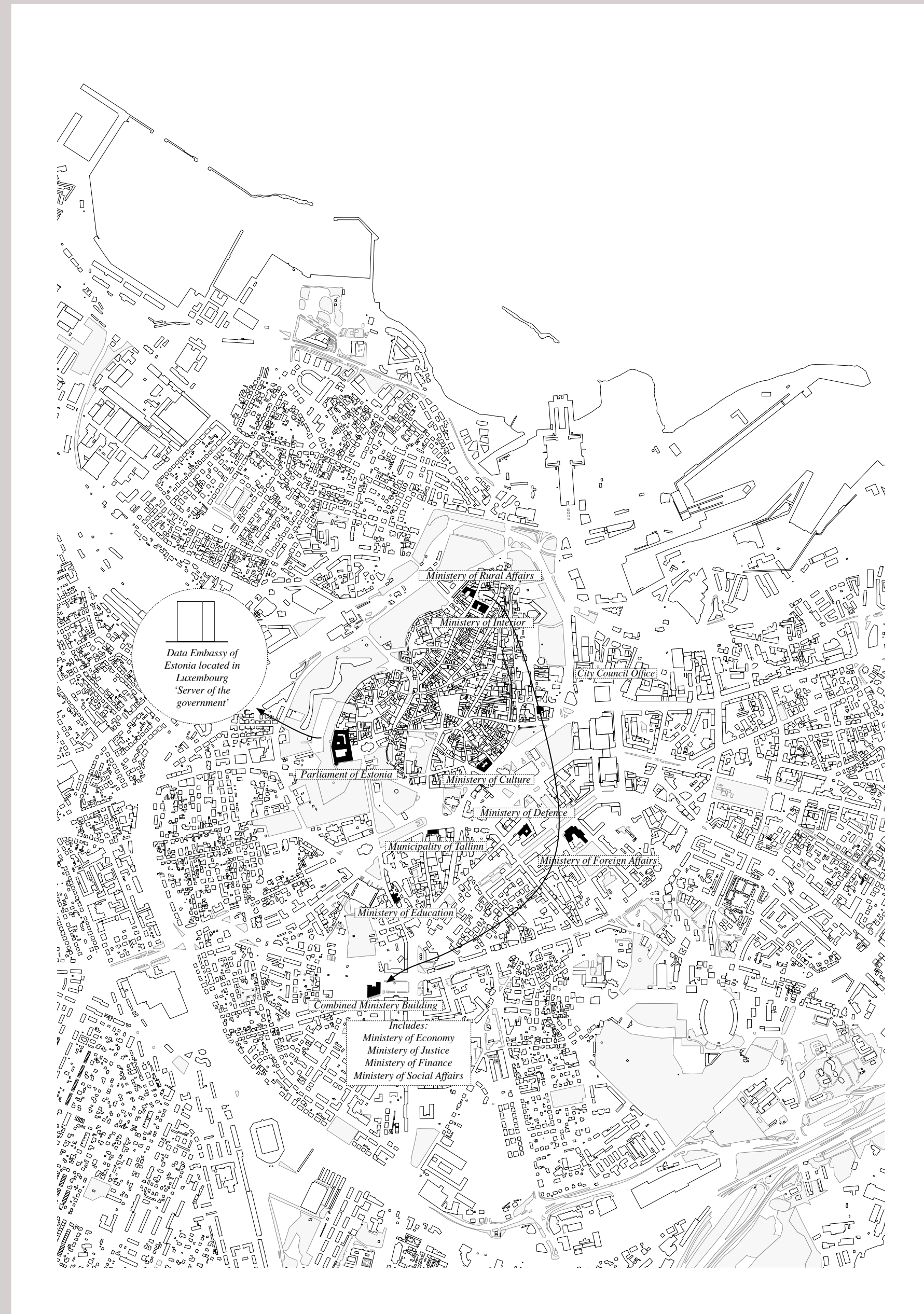

E-DEMOCRACY

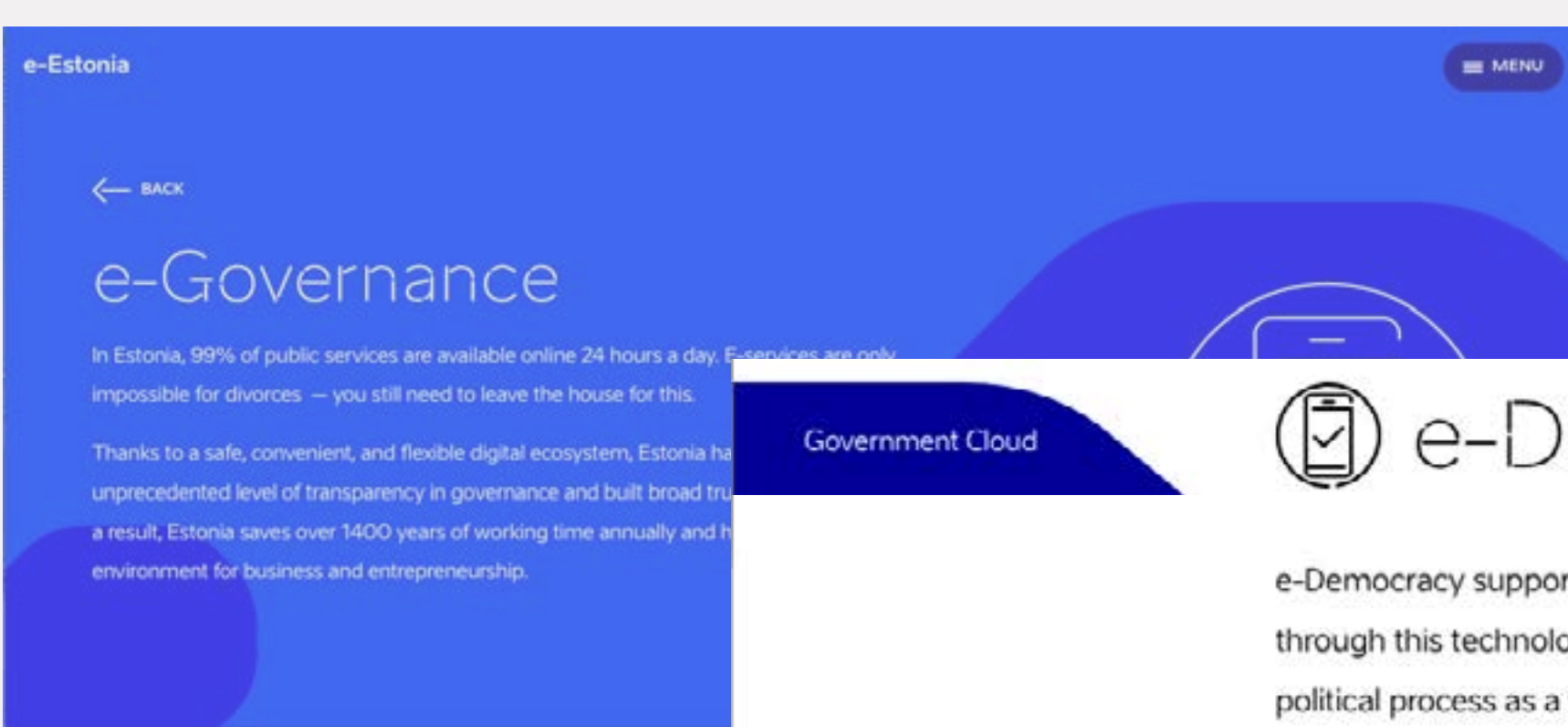

Government Cloud

e-Democracy & open data

e-Democracy supports and enhances democratic processes and institutions through this technology. It offers citizens the opportunity to participate in the political process as a vital part of the development of e-Governance.

#5
The Open Data Maturity Report

- Government Cloud
- Data Embassy
- e-Democracy & open data**
- Justice & public safety
- e-Services & registries

e-Democracy & open data

Internet voting (i-Voting) is a unique solution that conveniently engages citizens in the governance process. This system allows voters to cast their ballots from any internet-connected computer anywhere in the world. During a designated pre-voting period, the voter logs into the system using their government-issued e-ID and casts a ballot. The voter's identity is removed from the ballot before it reaches the National Electoral Commission for counting, thereby ensuring anonymity.

Since 2017, 16- and 17-year-old citizens have been eligible to vote in local elections. And historically, no less than 36% — and sometimes nearly 64% — of eligible voters participate in the i-Voting system.

e-Democracy supports and enhances democratic processes and institutions through this technology. It offers citizens the opportunity to participate in the political process as a vital part of the development of e-Governance.

46,7%
Estonians use i-Voting

since 2005
Estonia uses i-Voting

#5
The Open Data Maturity Report

- Government Cloud
- Data Embassy**
- e-Democracy & open data
- Justice & public safety
- e-Services & registries

Data Embassy

Data Embassy is an extension in the cloud of the Estonian government, which means the state owns server resources outside its territorial boundaries. This is an innovative concept for handling state information, since states usually store their information within their physical boundaries. Data Embassy resources are under Estonian state control, secured against cyberattacks or crisis situations with KSI Blockchain technology, and are capable not only providing data backups, but also operating the most critical services.

When we say "data embassy", we mean a data centre. It is located in Luxembourg under a Tier 4 level of security — the highest level for data facilities. It is not an embassy in the traditional diplomatic sense and while the founding agreement does take into account the Vienna Convention on Diplomatic Relations, it is something completely new under international law. It is fully under the control of Estonia, but has the same rights as physical embassies such as immunity.

Luxembourg is the first data embassy location because of the high quality technical capacity, but also because of their openness to work with this new concept. In this collaboration, Luxembourg and Estonia are pathfinders in creating a unique and innovative way to ensure digital continuity in the world.

The Data Embassy kick-off took place in 2015 and the finalised agreement between Estonia and Luxembourg was signed in 2017. The development of the Estonian Government Cloud is a collaboration between the Estonian Government and private sector companies, including Cybernetica, Dell EMC, Ericsson, OpenNode, and Tella.

#1
data embassy in Luxembourg

DEMOCRACY

Democracy Index 2006-22															
Estonia	7.96	7.84	7.84	7.90	7.97	7.79	7.85	7.85	7.74	7.61	7.61	7.61	7.68	7.68	7.74

Table 1: Democracy progress of Estonia from 2006 until 2022 by The Economist. Scoring higher than an 8.0 makes it a full democracy, under a 8.0 it is considered a 'flawed democracy'.

Democracy Index 2022								
	Overall score	Rank	Change in rank from previous year	I Electoral process and pluralism	II Functioning of government	III Political participation	IV Political culture	V Civil liberties
Estonia	7.96	27	0	9.58	7.86	6.67	6.88	8.82

Table 2: Democracy Index of Estonia in 2022 by The Economist. Scoring higher than an 8.0 makes it a full democracy, under a 8.0 it is considered a 'flawed democracy'.

CITY ARCHITECT

Kuus, Indrek. "Tallinna peaarhitekt Endrik Mänd otsustas ametist lahkuda." EER. June 18, 2019. <https://www.err.ee/953507/tallinna-peaarhitekt-endrik-mand-otsustas-ametist-lahkuda>.

ERR.ee NEWS TV RADIO FOR KIDS JUPITER

news ESTONIA OPINION ECONOMY FOREIGN COUNTRY CULTURE SPORTS MENU

The chief architect of Tallinn, Endrik Mänd, decided to resign

ESTONIA
18.06.2019 14:04



City architect Endrik Mänd Author/source: Siim Lövi /ERR

The city's chief architect Endrik Mänd, who worked in Tallinn's city planning office, decided to resign on his own accord, according to the city government's draft order, he will receive 20,000 euros in compensation.

Mänd has worked in the city planning office for 21 years, he will leave the office on July 8. The amount of compensation for Mänd is six months' salary, and this money is allocated from the Tallinna reserve fund.

Editor: Indrek Kuus

FASCINATION

HOW TO CREATE SPACE FOR PUBLIC DISCUSSION?

SPECIFICALLY TO TALLINN, HOW WOULD THAT SPACE RELATE TO THE LACK OF INVOLVEMENT BETWEEN CITIZENS AND MUNICIPALITY IN THE BUILT ENVIRONMENT?

HOW SHOULD IT BE POSITIONED IN THE CITY OF TALLINN?

DEFINITION OF THE WORD FORUM

Giovanni Paolo Panini (ca. 1692-1765). View of the Roman Forum, 1747.

**ACCORDING TO COLLINS DICTIONARY,
THE DEFINITION OF THE WORD
FORUM IS:**

**1. A PLACE, SITUATION, OR GROUP
IN WHICH PEOPLE EXCHANGE IDEAS
AND DISCUSS ISSUES, ESPECIALLY
IMPORTANT PUBLIC ISSUES.**

**2. AN AREA OF A WEBSITE WHERE
USERS CAN POST COMMENTS AND
HAVE DISCUSSIONS.**

**3. IN ANCIENT ROMAN TOWNS, THE
FORUM WAS A SQUARE WHERE
PEOPLE MET TO DISCUSS BUSINESS
AND POLITICAL MATTERS.**



i Background



ii Design

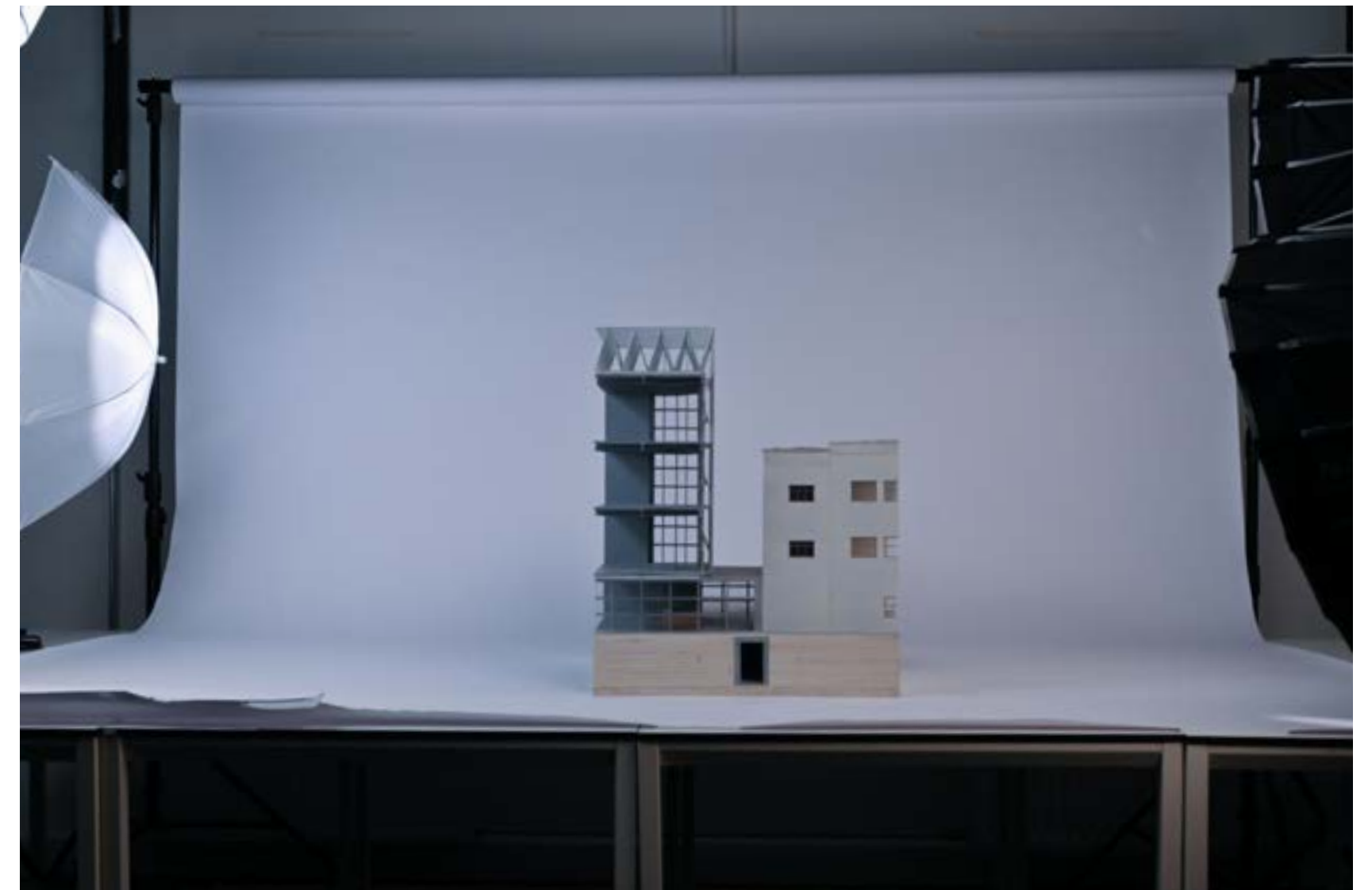

LOCATION



LOCATION



LOCATION



North-South connection

East-West connection



LOCATION

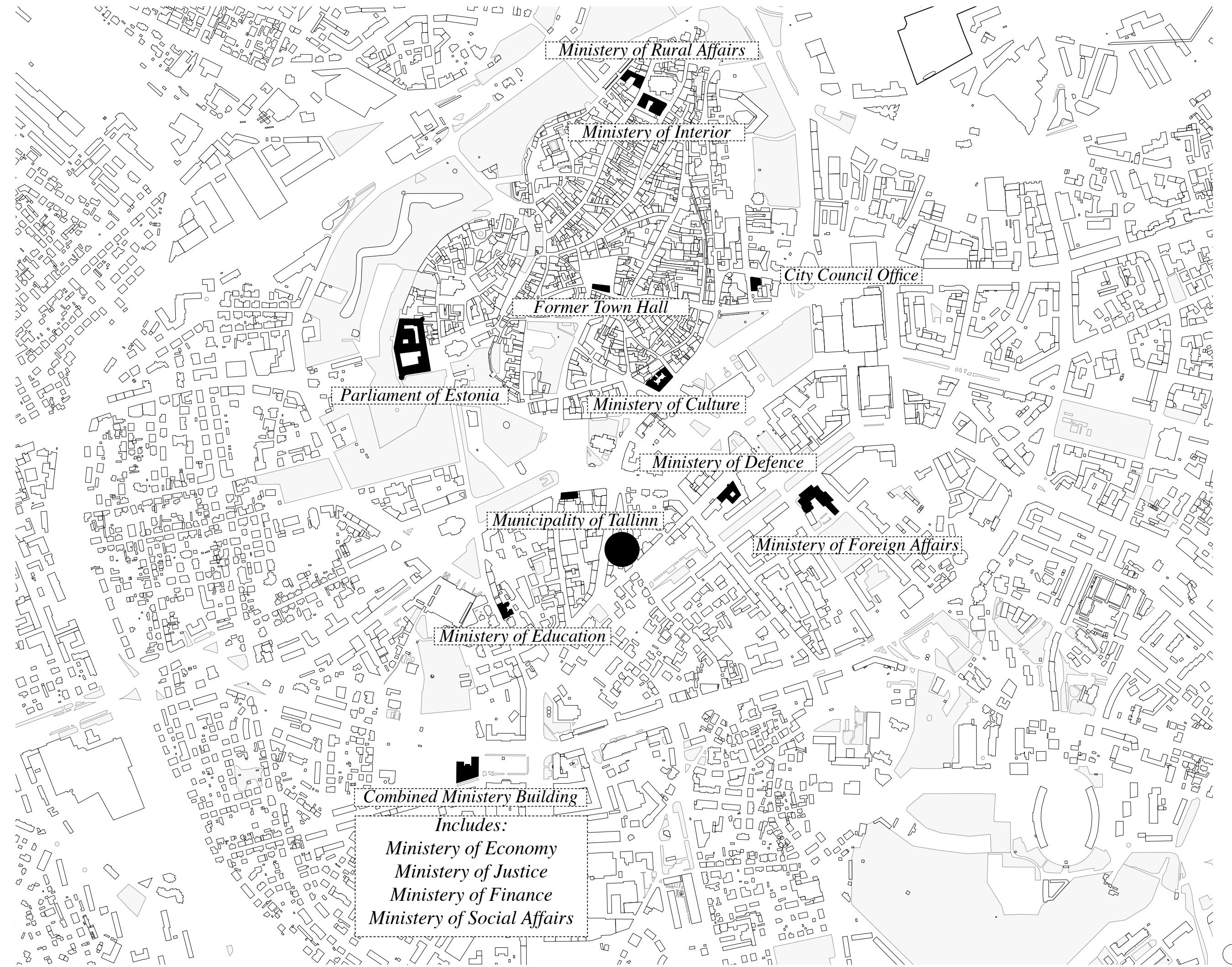

LOCATION



ROUTE

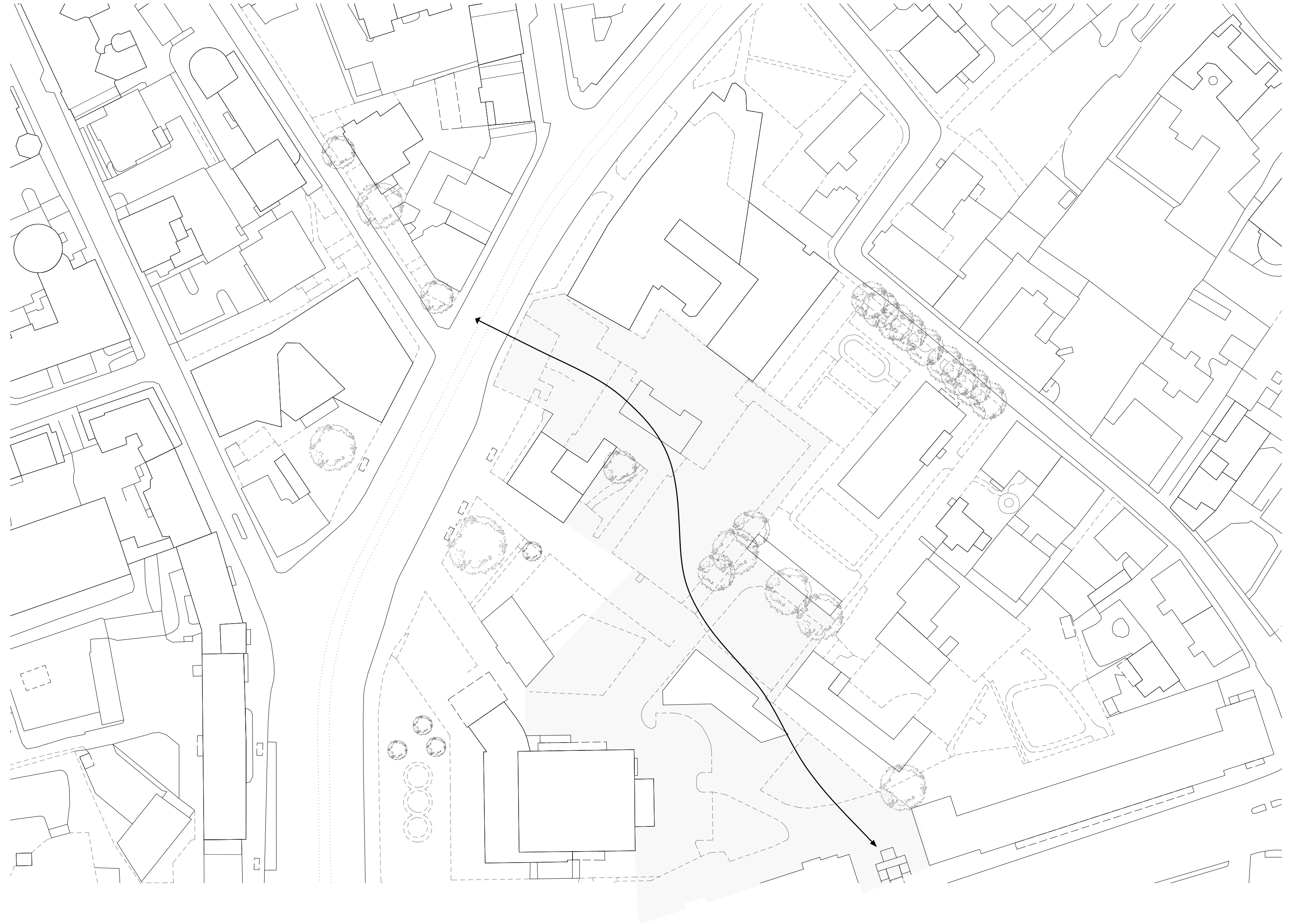

LOCATION



LOCATION



LOCATION



LOCATION



LOCATION



LOCATION



PROPOSAL

THE PROPOSAL, “FORUM FOR THE BUILT ENVIRONMENT,” SURGED IN RESPONSE TO THE OBSERVED DEFICIENCY OF PHYSICAL SPACES CONDUCTIVE TO REFLECTION, GATHERINGS, AND CITIZEN PARTICIPATION IN THE CITY.

PROPOSAL

THE PROPOSAL, “FORUM FOR THE BUILT ENVIRONMENT,” SURGED IN RESPONSE TO THE OBSERVED DEFICIENCY OF PHYSICAL SPACES CONDUCTIVE TO REFLECTION, GATHERINGS, AND CITIZEN PARTICIPATION IN THE CITY. **ITS PRIMARY AIM IS TO FUNCTION AS A PLATFORM FOR DEMOCRATIC DIALOGUE AMONG TALLINN’S CITIZENS ON MATTERS OF PUBLIC INTEREST WITHIN THE DOMAIN OF THE BUILT ENVIRONMENT.**

PROPOSAL

CONSISTING OF FOUR DISTINCT BUILDINGS, THE PROJECT ENCAPSULATES THE MULTIFACETED ESSENCE OF TALLINN. IT SYMBOLIZES THE DIVERSITY OF PERSPECTIVES AND IDENTITIES, EMBODYING THE PRINCIPLES OF DEMOCRACY.

FUNCTIONS

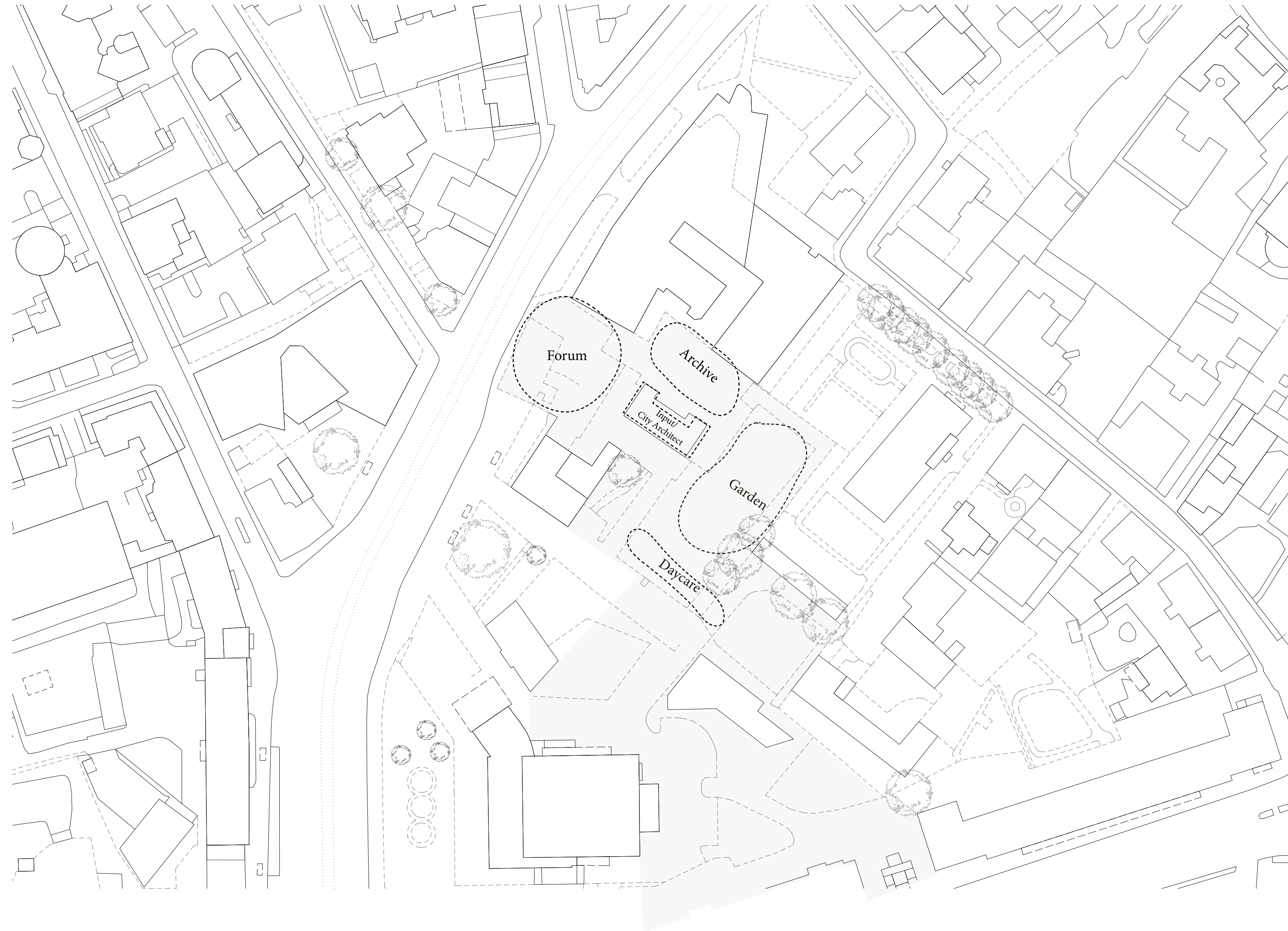

LOCATION

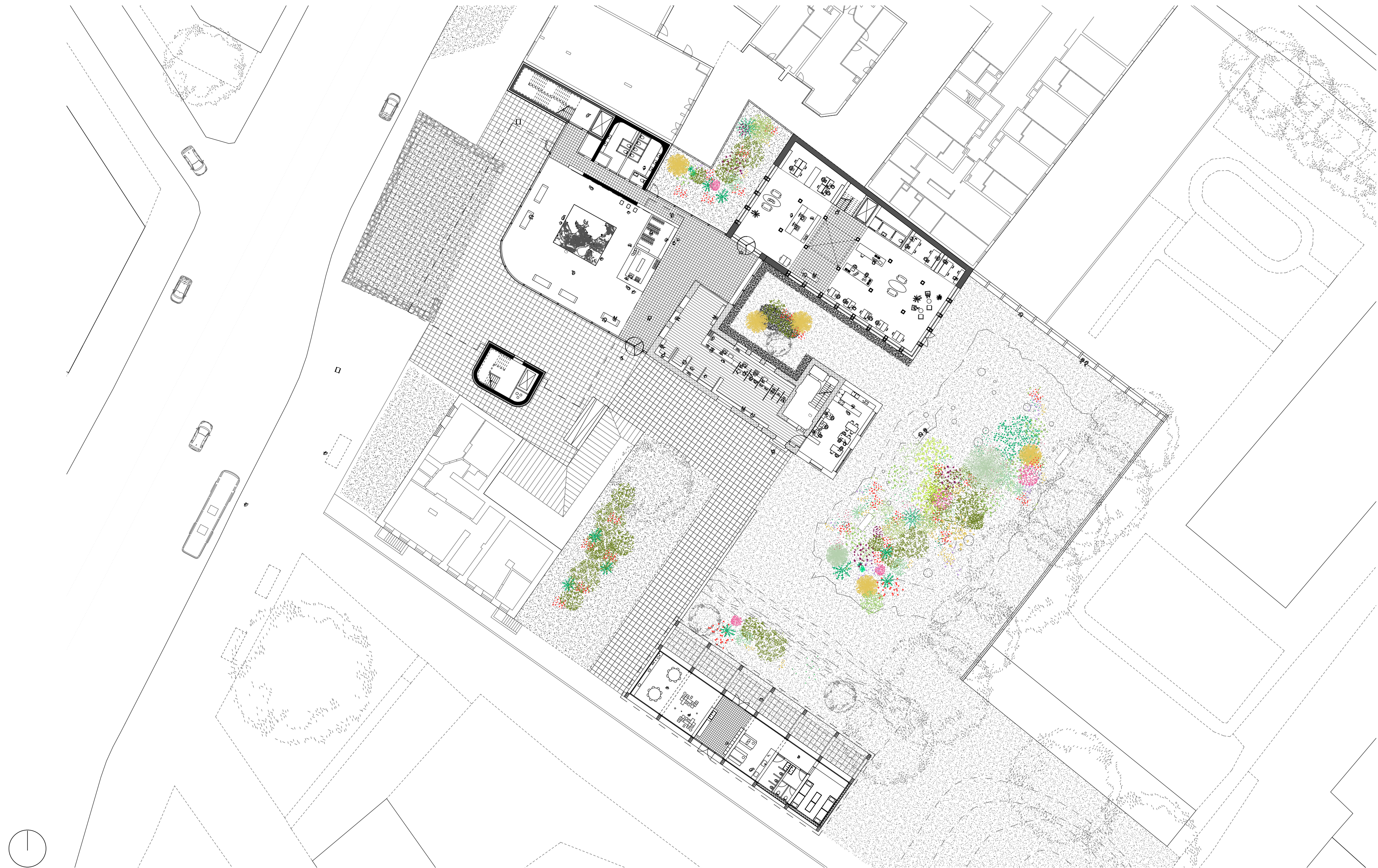

PROPOSAL



PROPOSAL

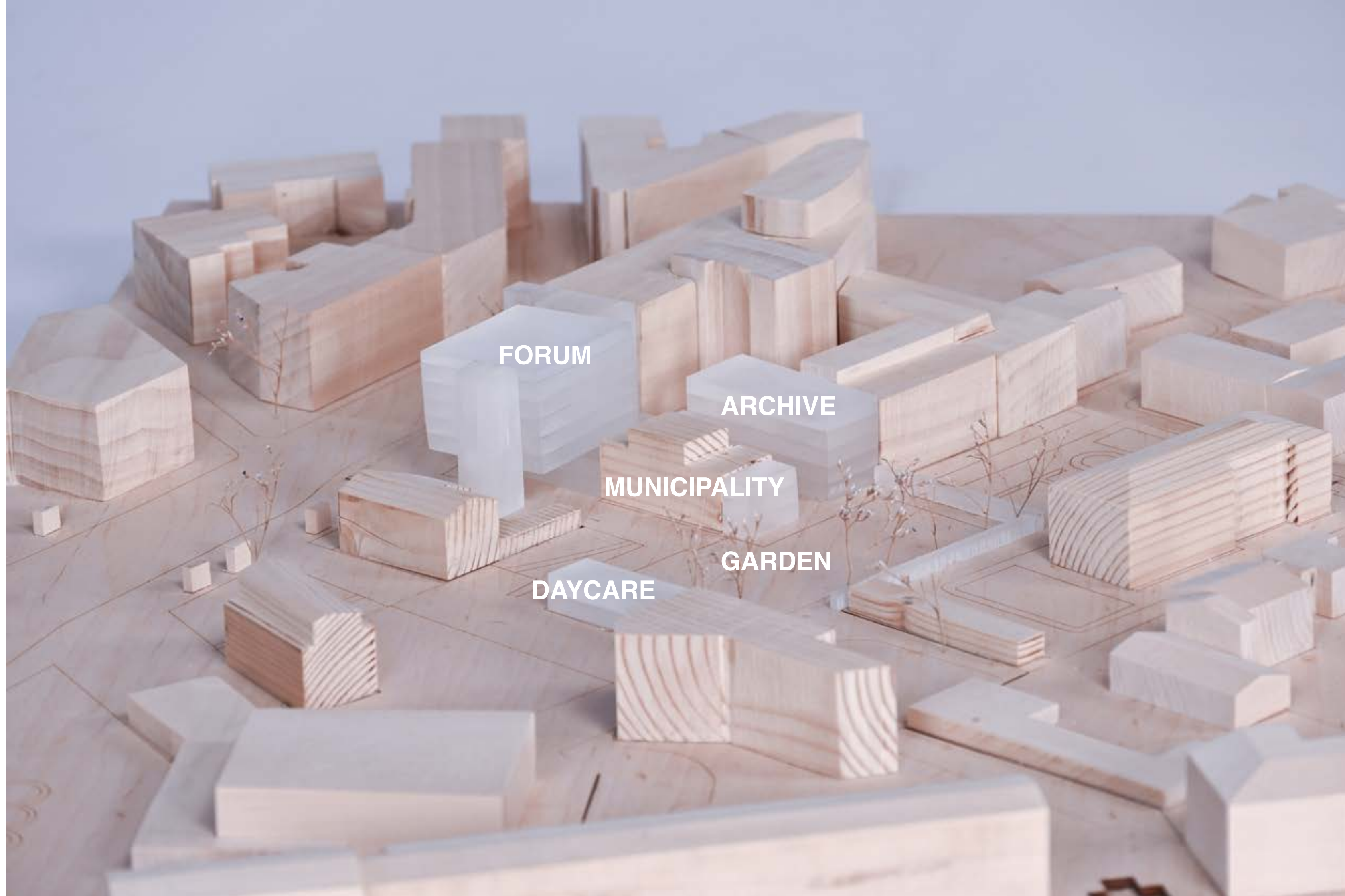

PROPOSAL

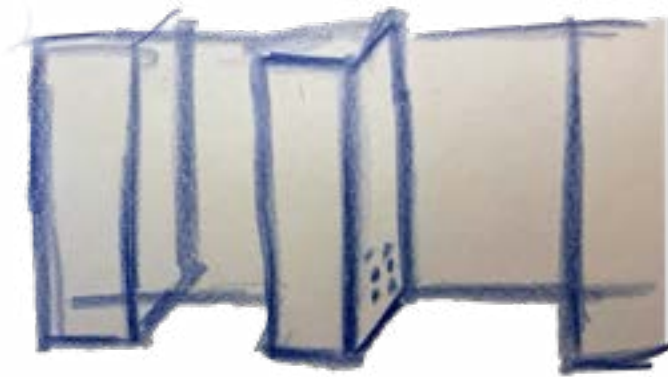
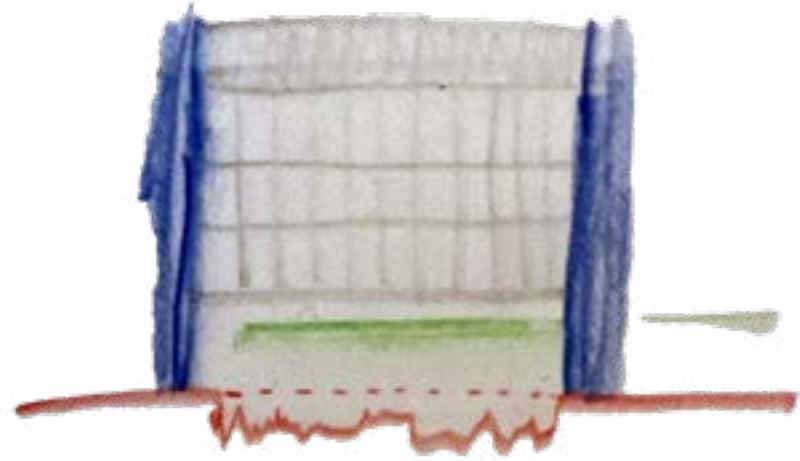

PROPOSAL

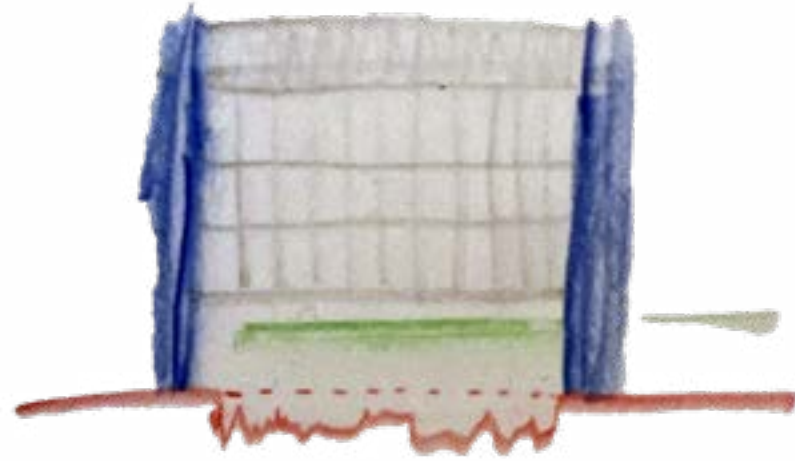

1. FORUM



2. MUNICIPALITY



3. ARCHIVE



4. KINDERGARTEN



5. GARDEN

PROPOSAL THROUGH SECTIONS



FORUM



DEMOLITION



DEMOLITION



DEMOLITION



PROPOSAL



LOCATION

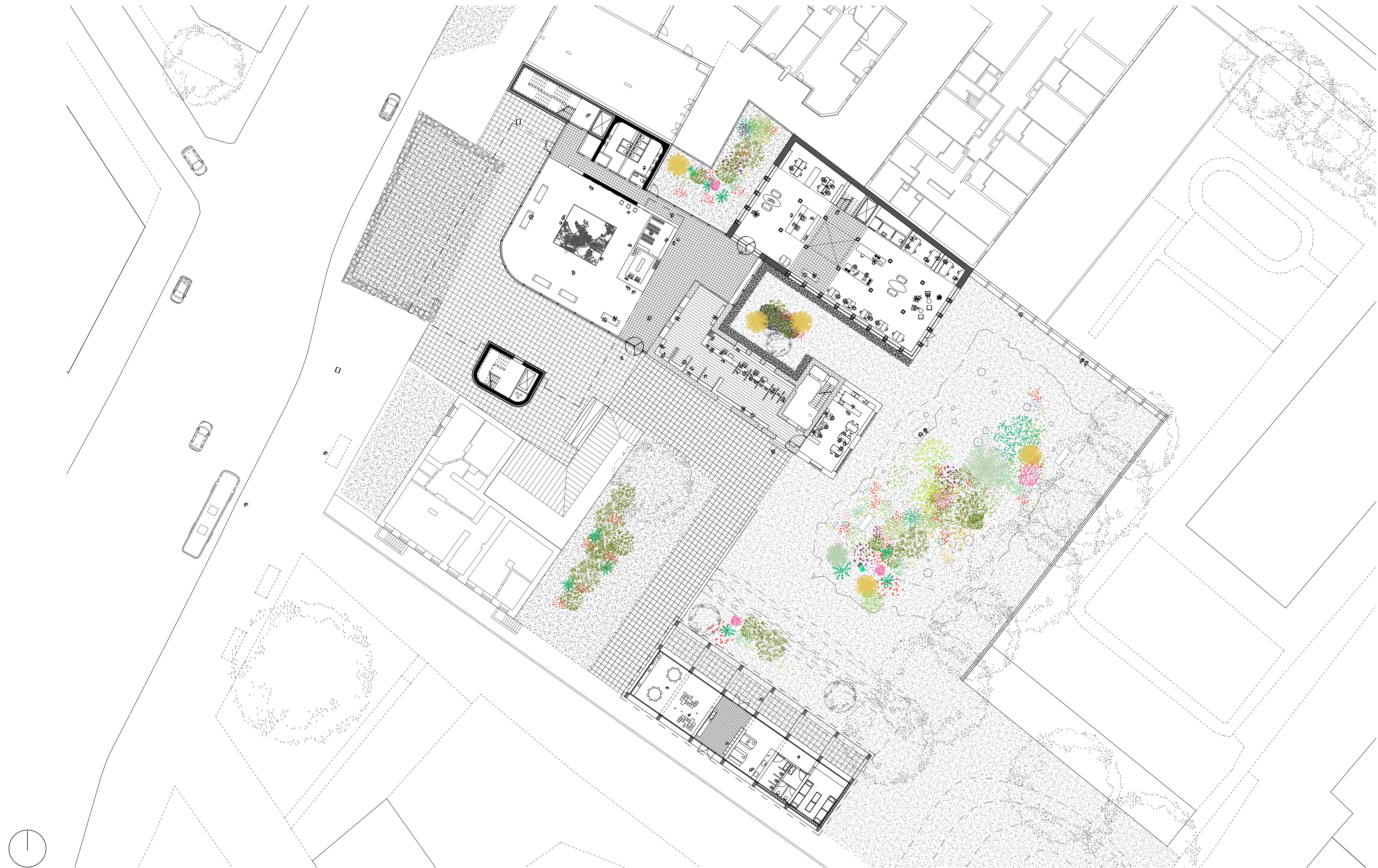

FORUM

1:100

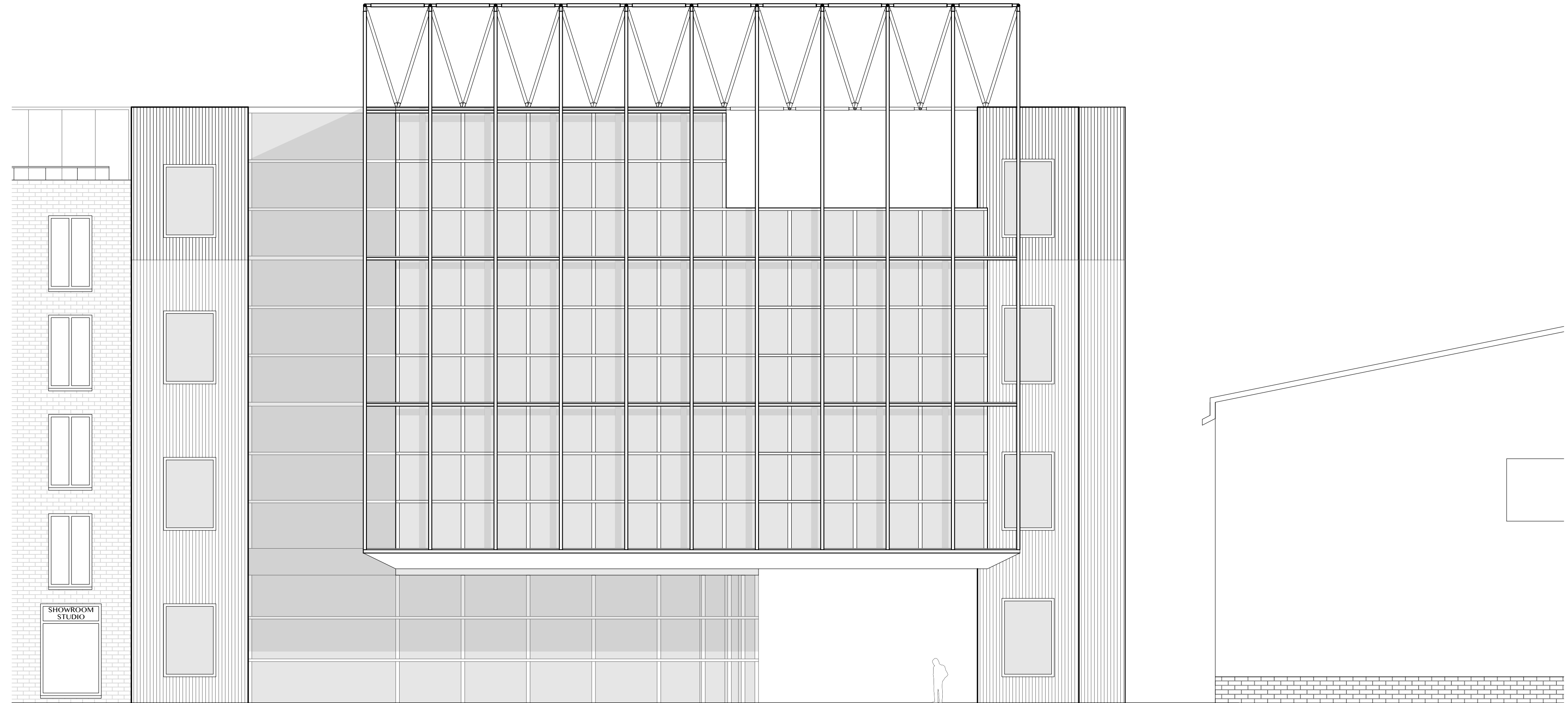

STRUCTURE

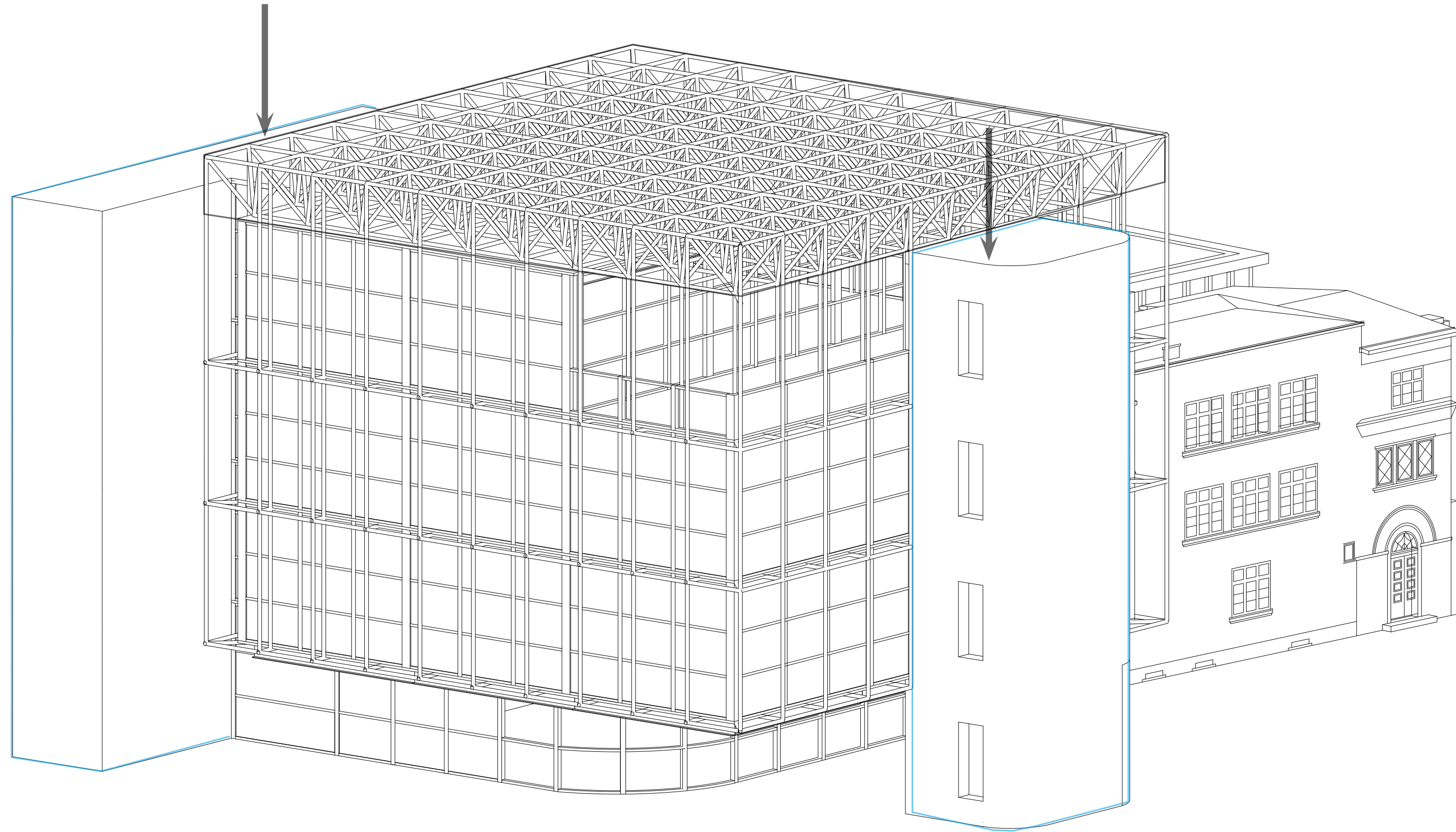

FORUM

1:200

Entrance

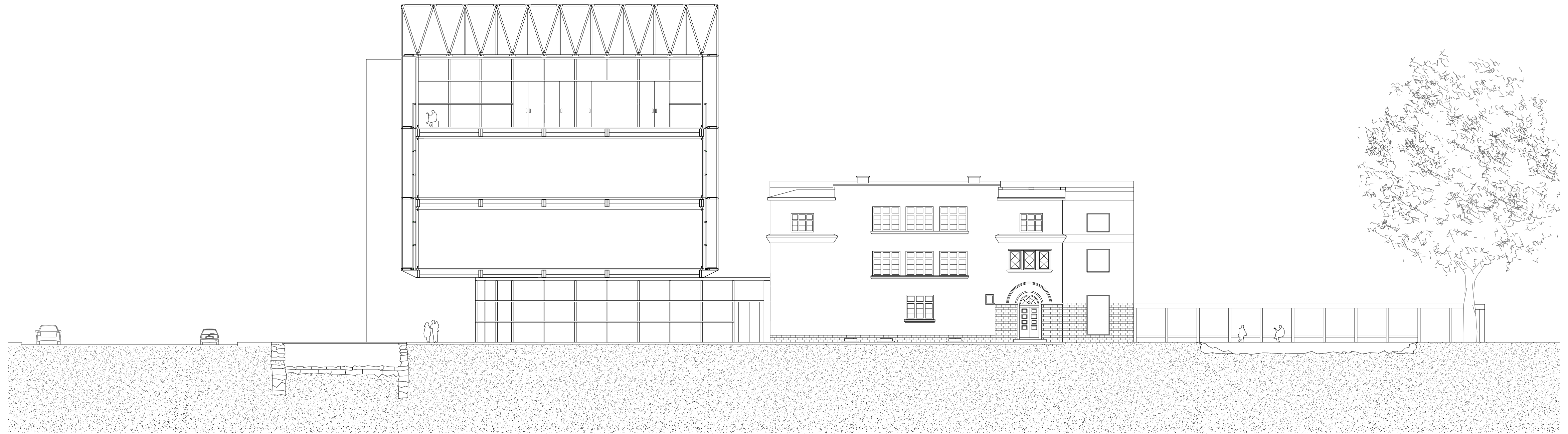

FORUM

1:200

Entrance

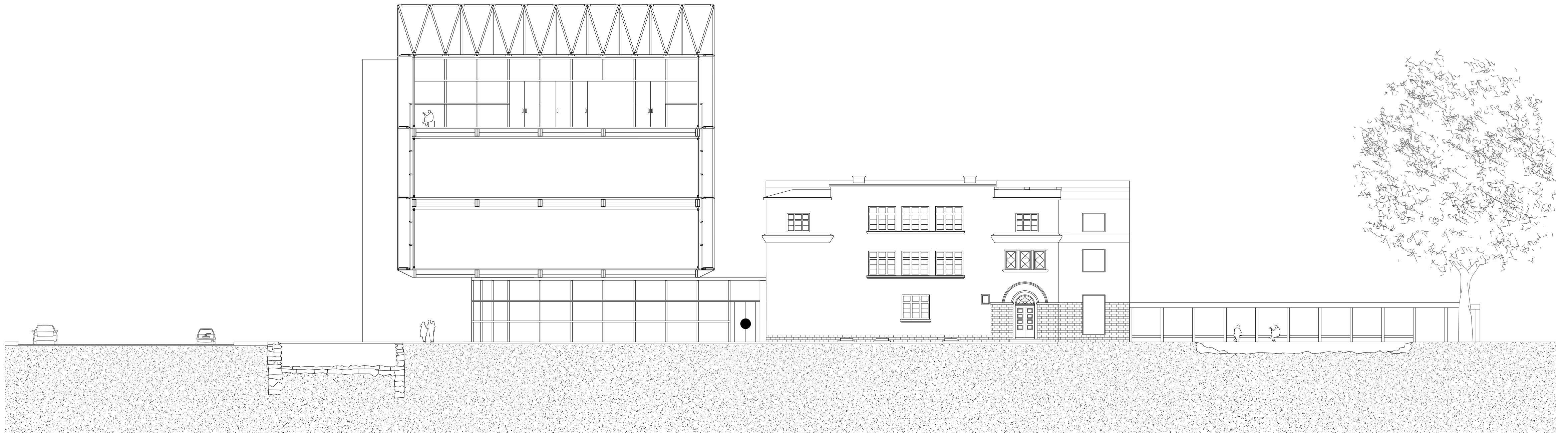

FORUM

Entrance



FORUM

1:100
Ground Floor

- 1 Entrance
- 2 Exhibition city development
- 3 Front desk
- 4 Cloak room
- 5 Toilets
- 6 Technical Space
- 7 Circulation

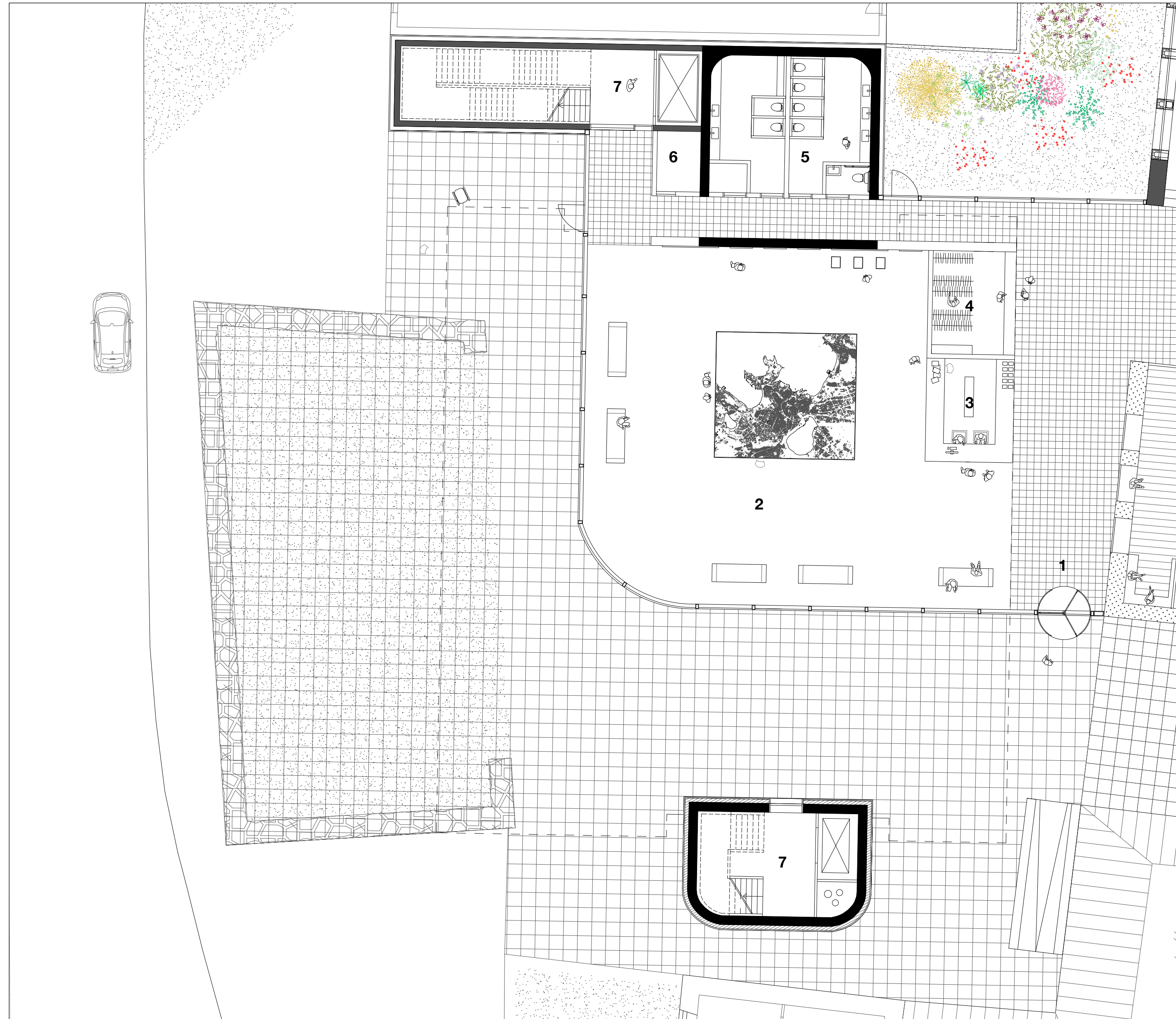

FORUM

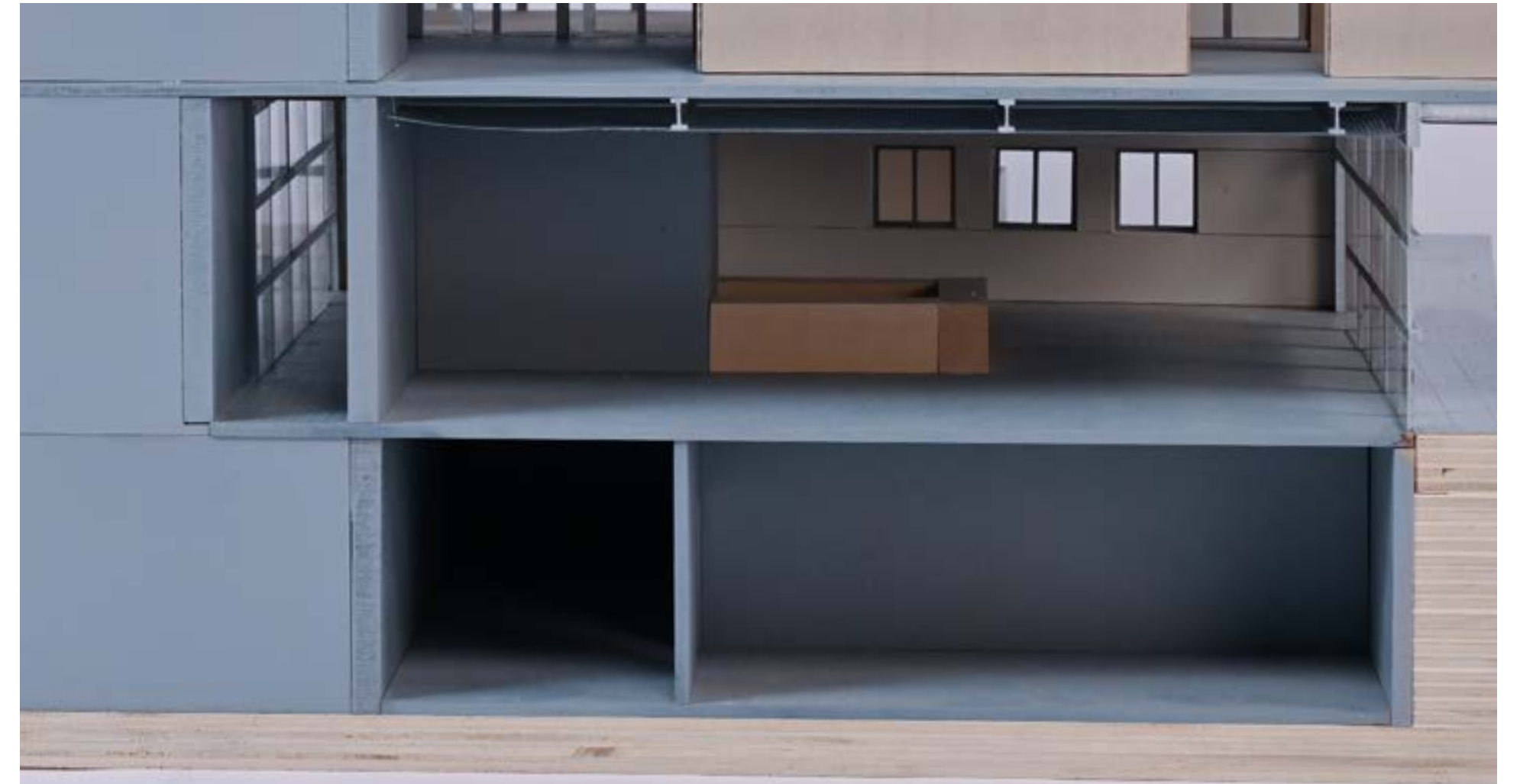

FORUM

1:20

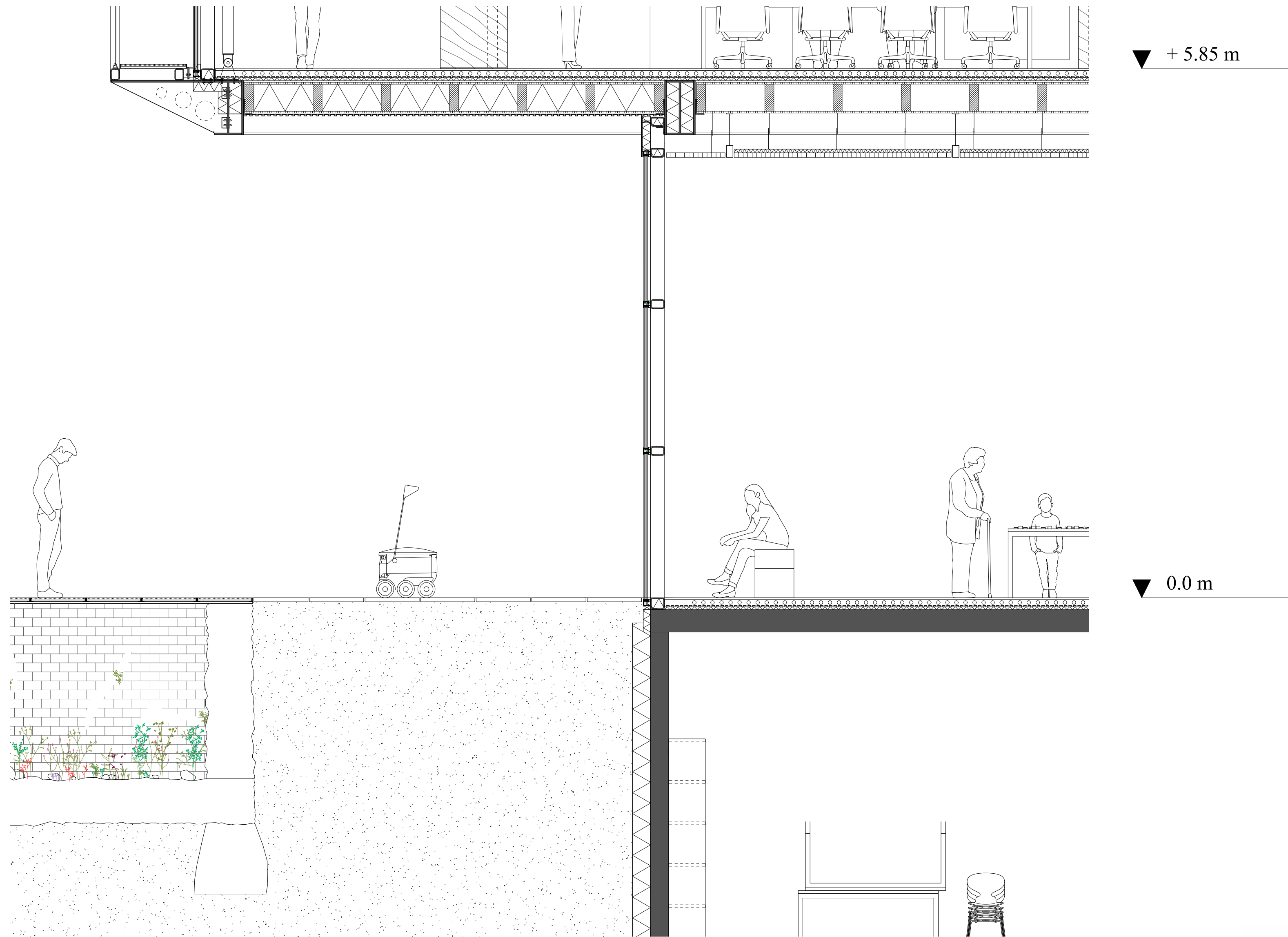

FORUM

1:100
Basement

- 1 Technical Space
- 2 Storage
- 3 Garbage
- 4 Circulation

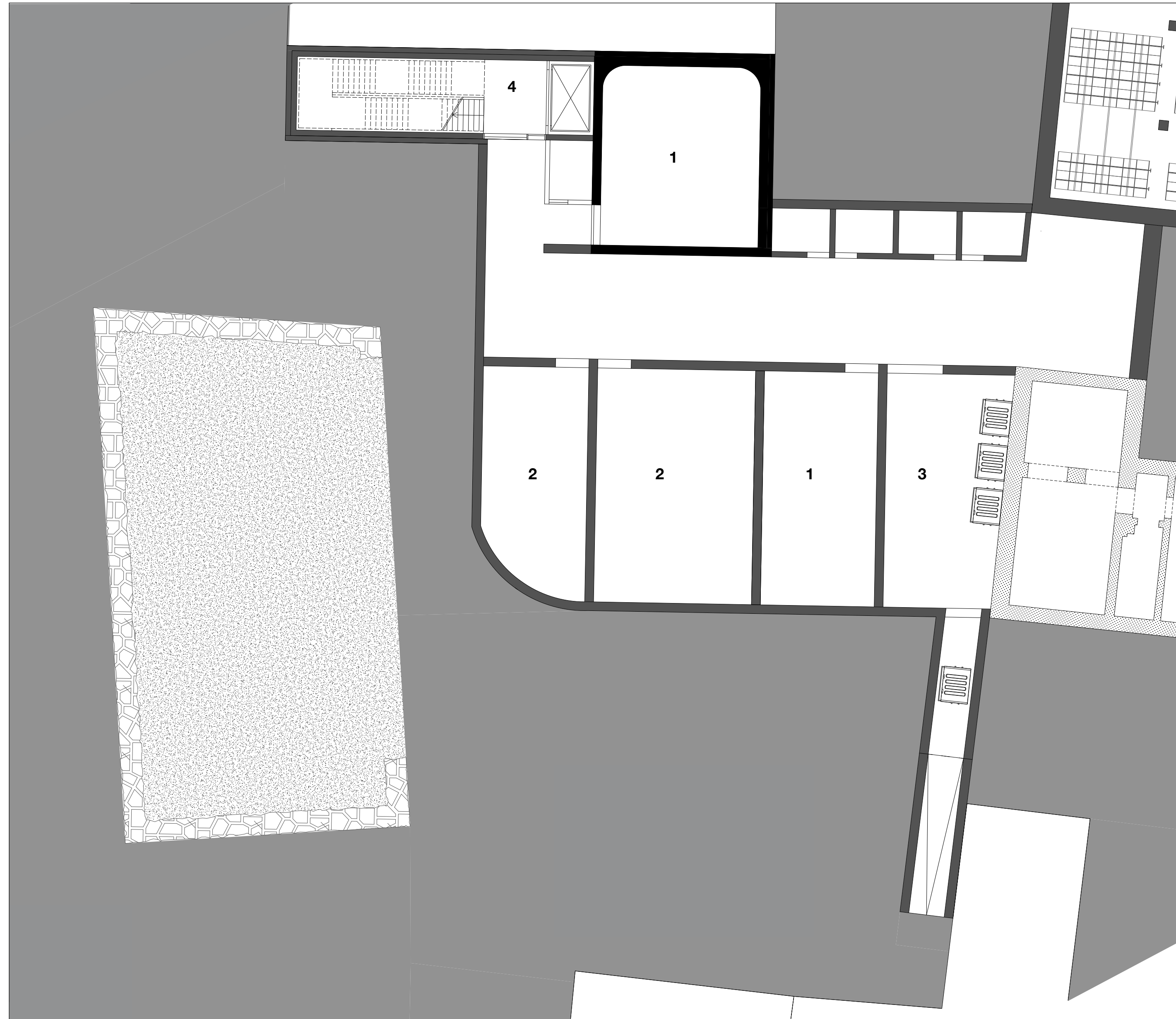

FORUM



FORUM

1:20

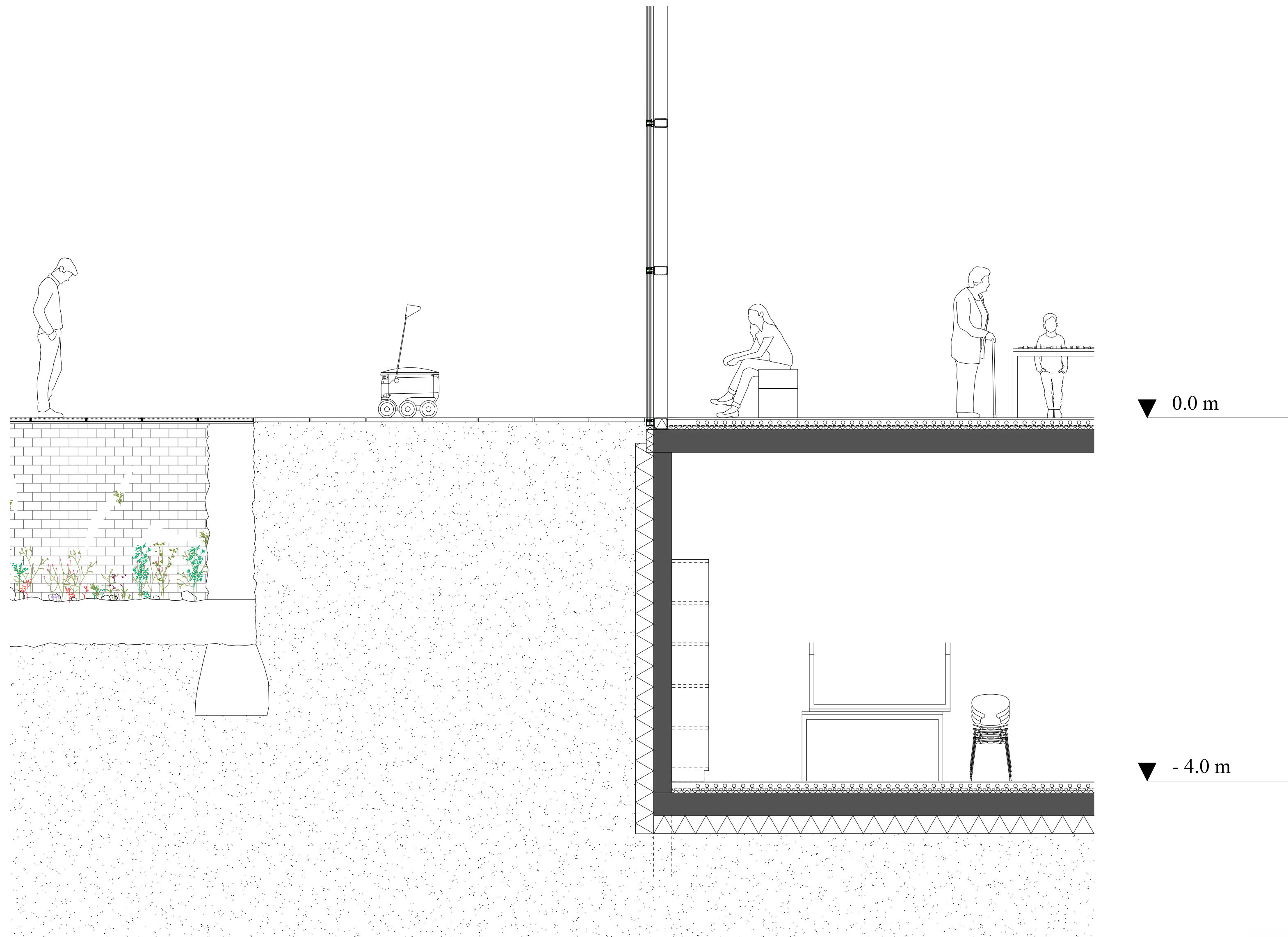

FORUM

1:100
First floor / Set-up Auditorium

- 1 Discussion space
- 2 Movable walls
- 3 Kitchenette
- 4 Toilets
- 5 Technical Space
- 6 Circulation

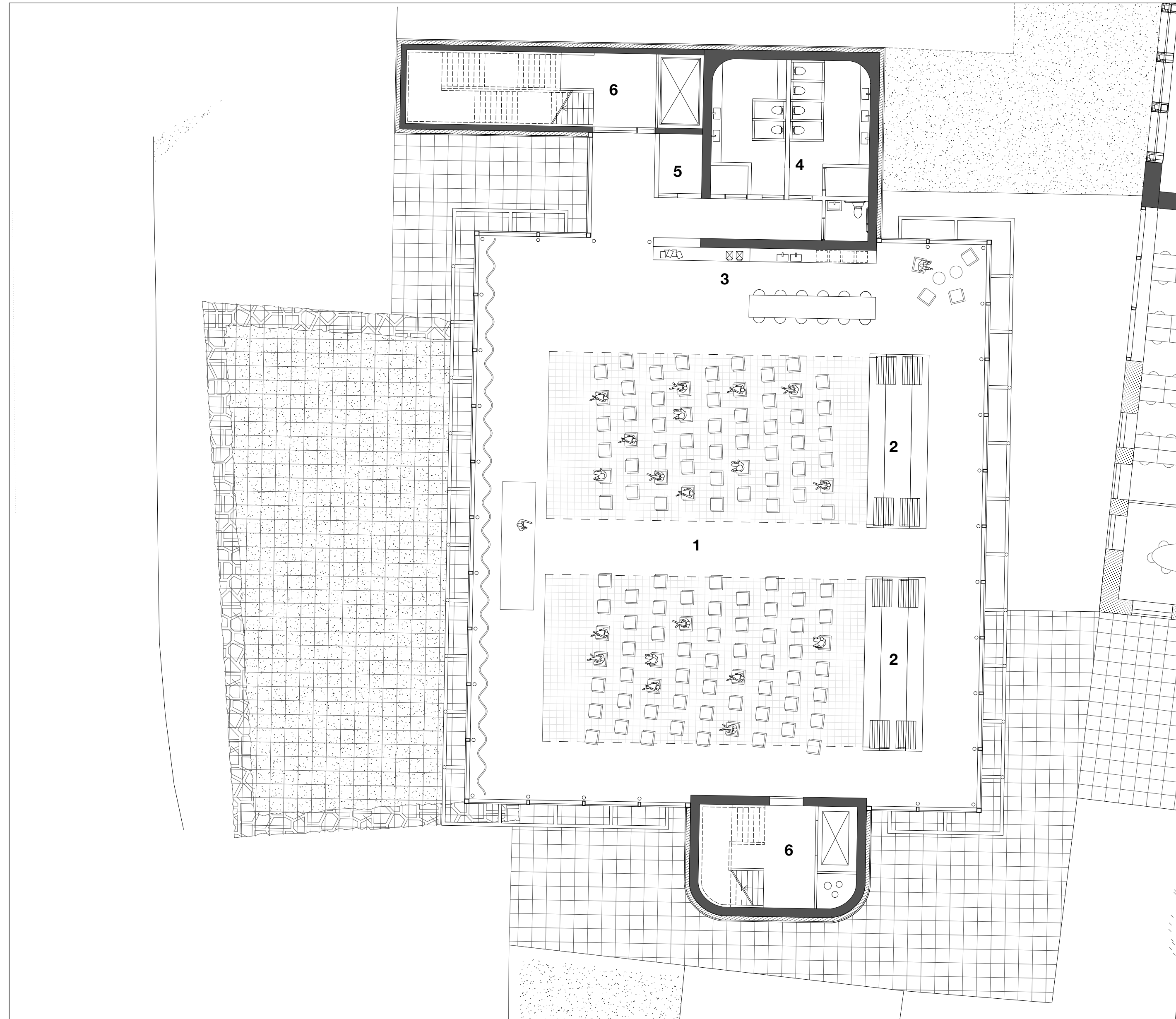

FORUM

1:100
First floor // four rooms

- 1 Discussion space
- 2 Movable walls
- 3 Kitchenette
- 4 Toilets
- 5 Technical Space
- 6 Circulation

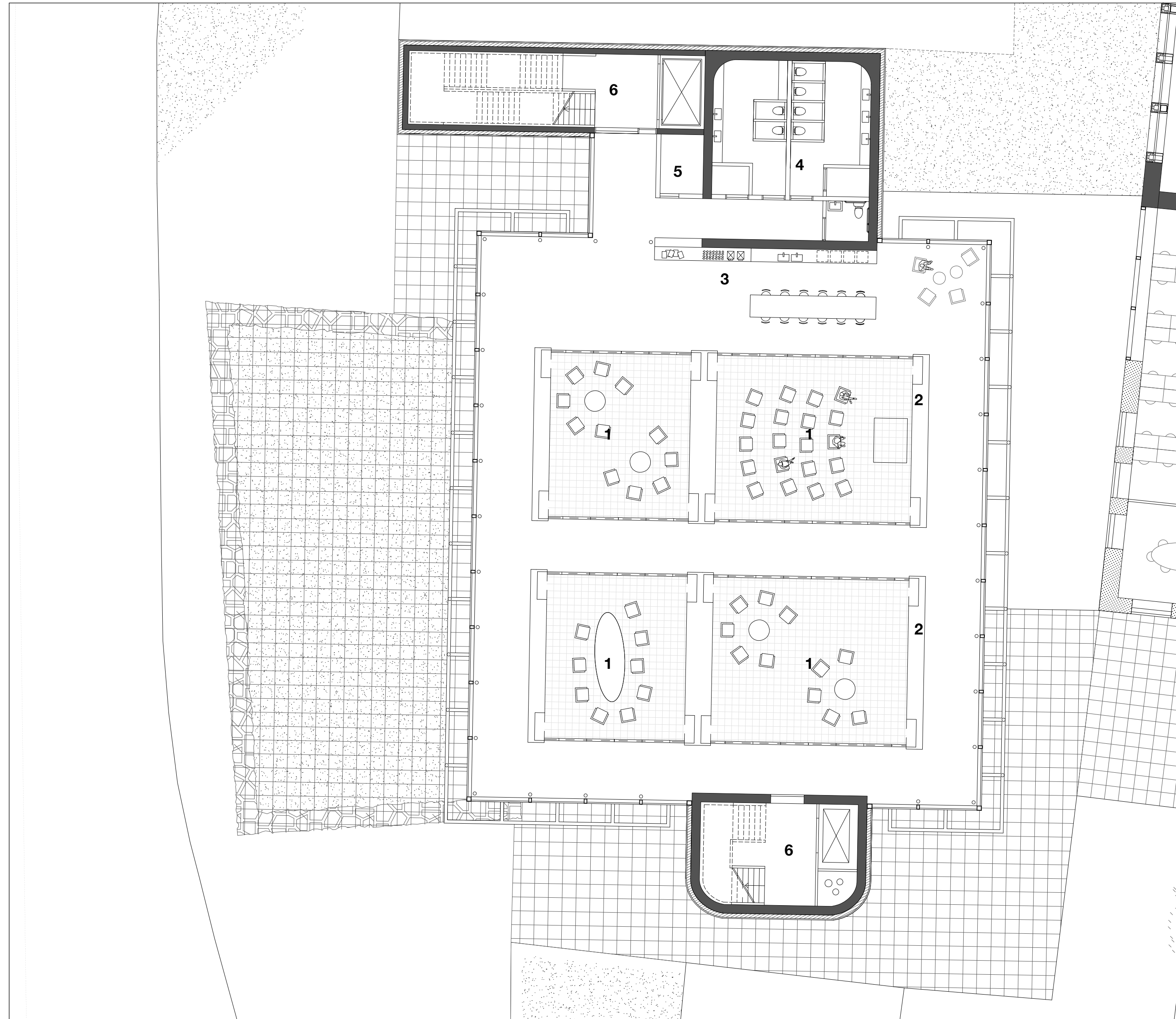

FORUM



FORUM



FORUM

1:100
Second floor

- 1 Meeting rooms
- 2 Movable walls
- 3 Kitchenette
- 4 Office space teams
- 5 Office space deep concentration
- 4 Toilets
- 5 Technical Space
- 6 Circulation

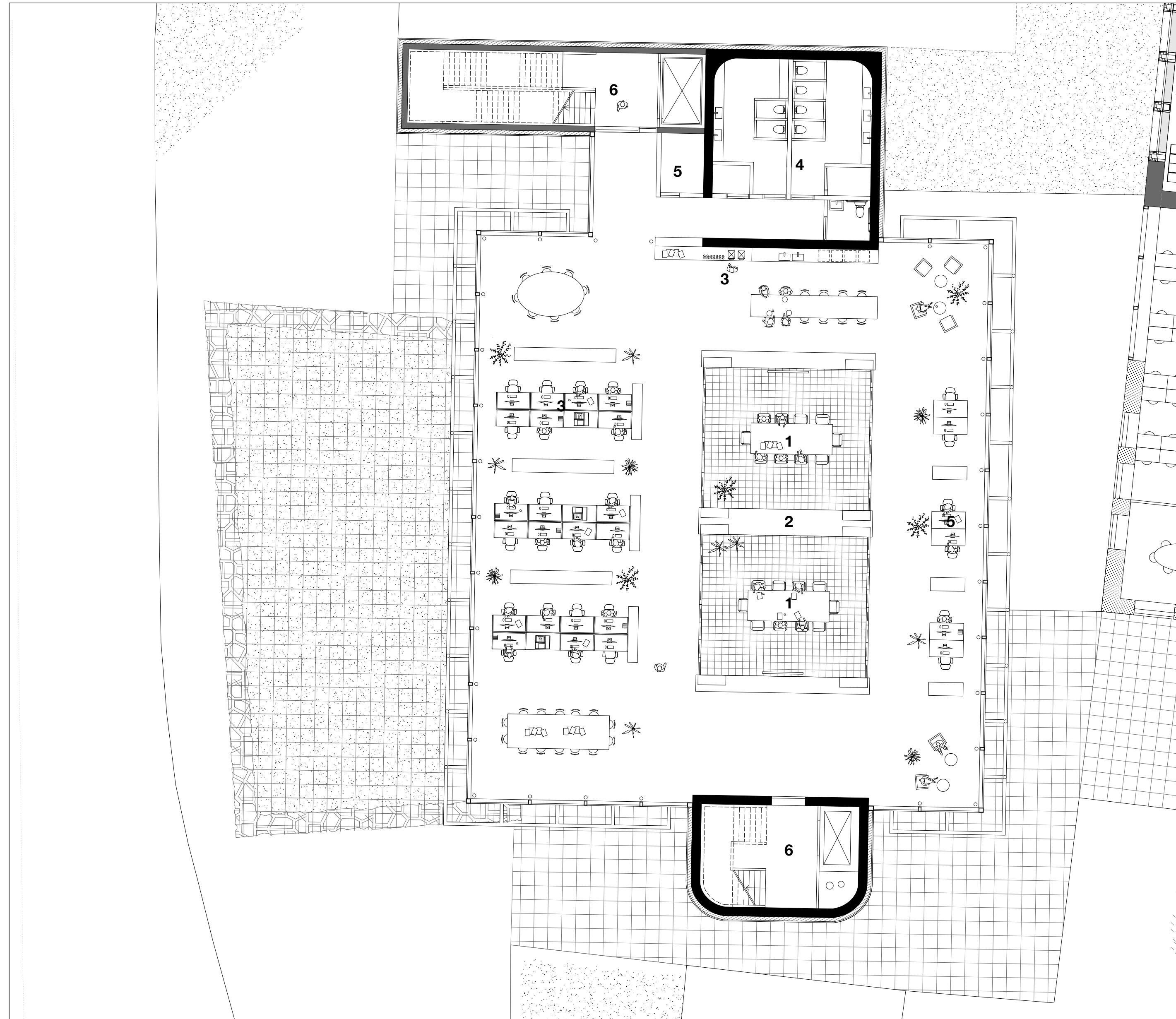

FORUM



FORUM

1:20
Second floor

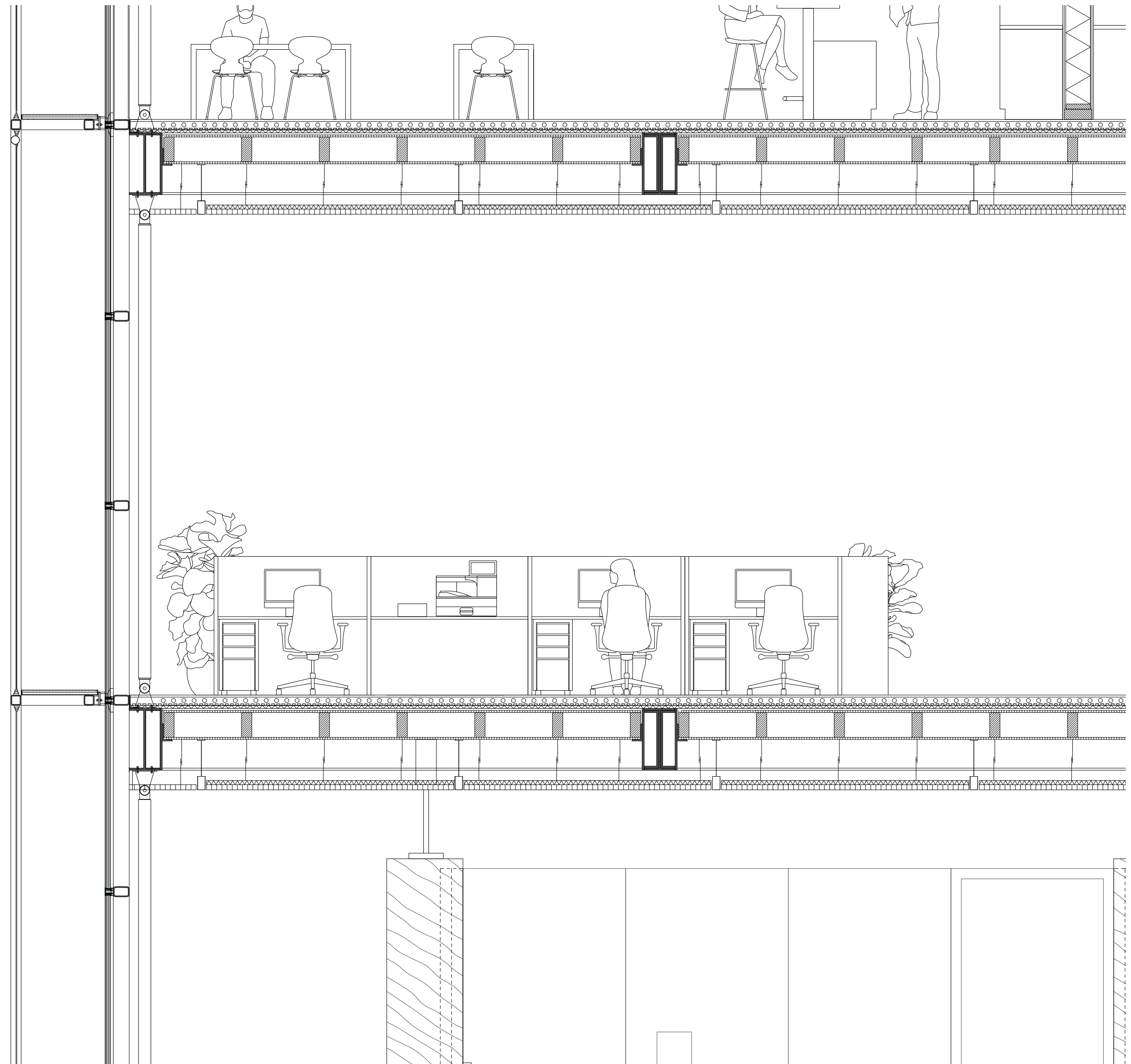

▼ + 17.05 m

▼ + 11.45 m



FORUM

1:20
Third floor

- 1 Restaurant
- 2 Kitchen
- 3 Workshop space
- 4 Roof terrace
- 5 Toilets
- 6 Technical Space
- 7 Circulation

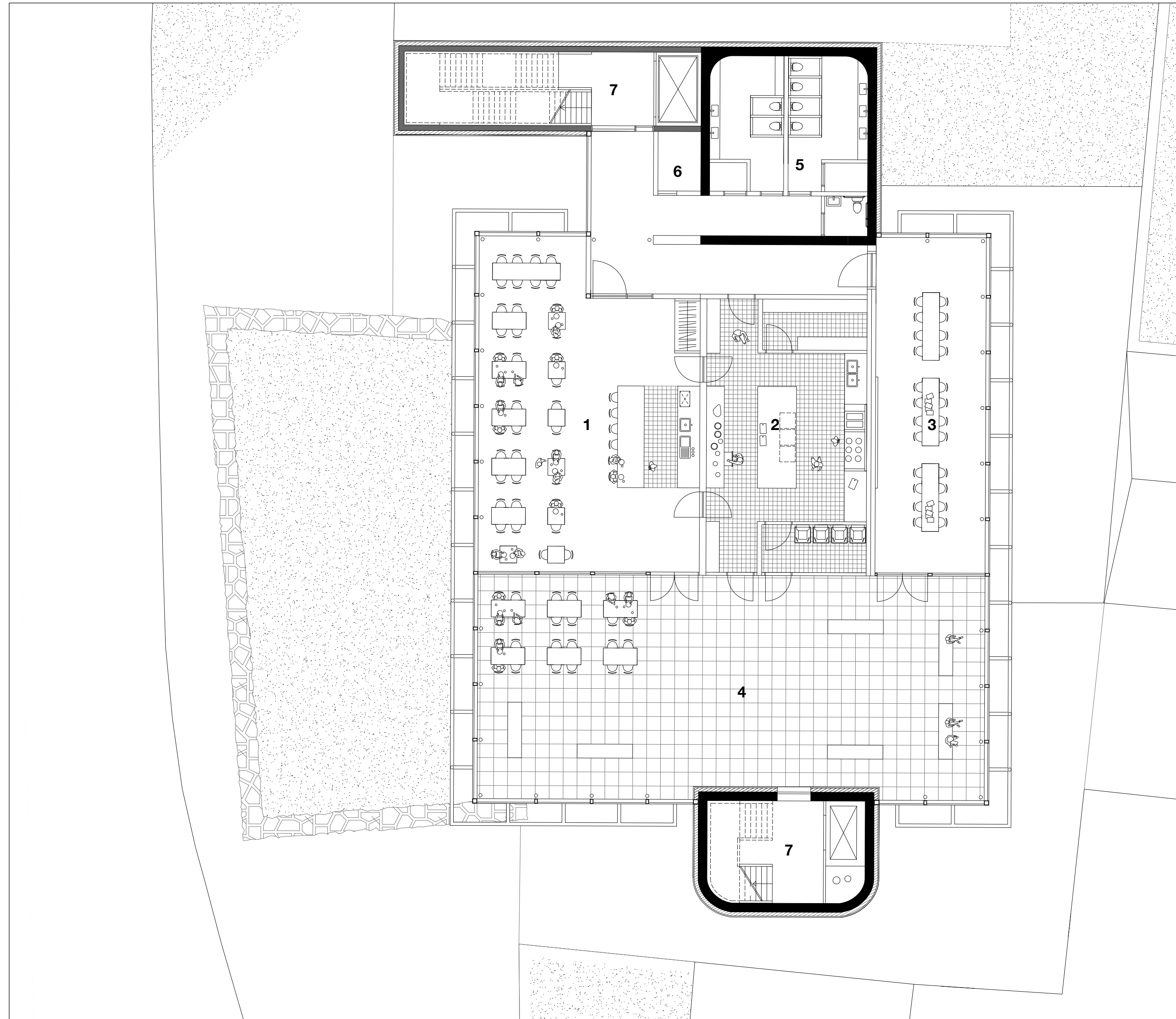

FORUM

1:20
Third floor

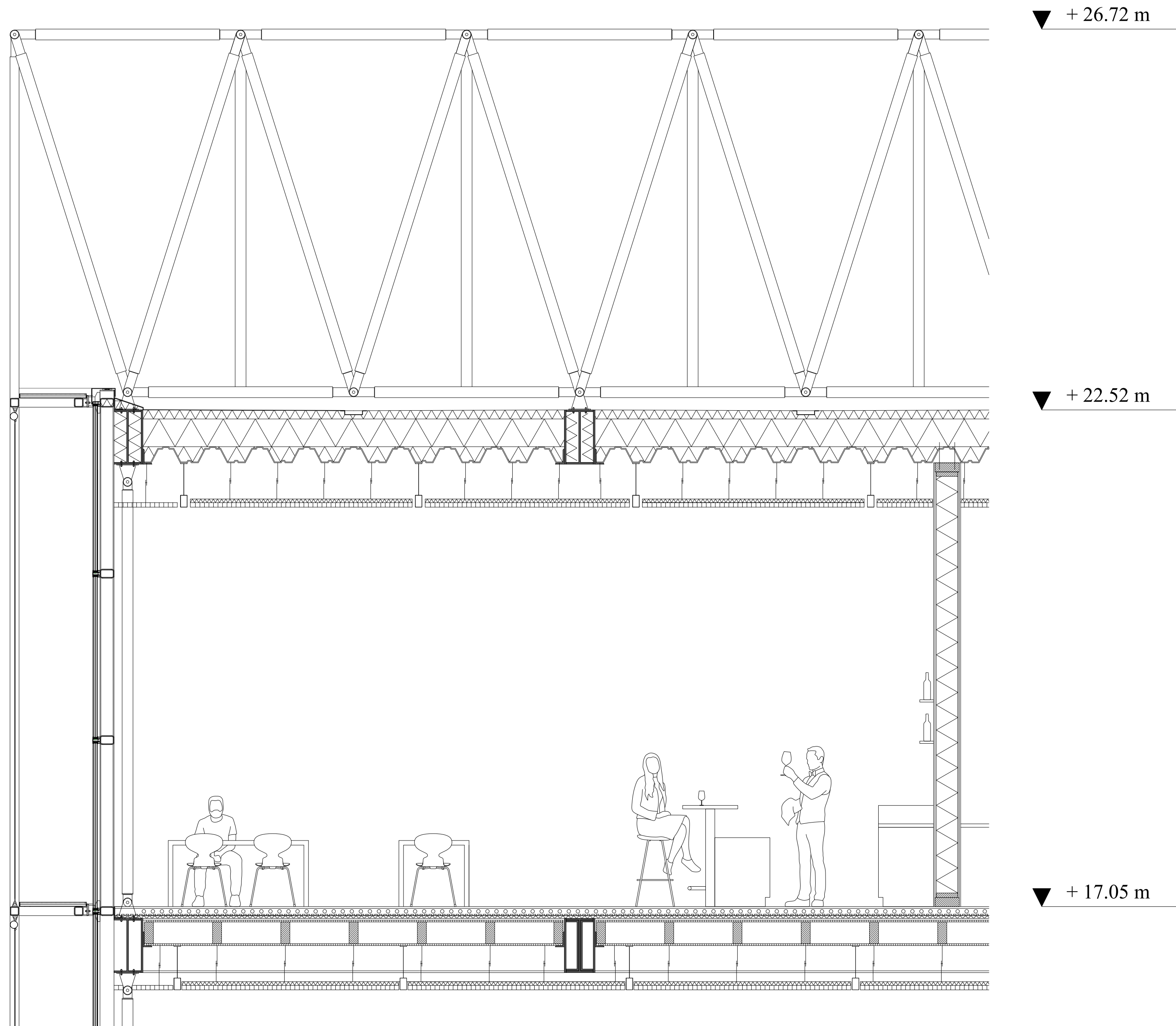

FORUM



FORUM

1:50

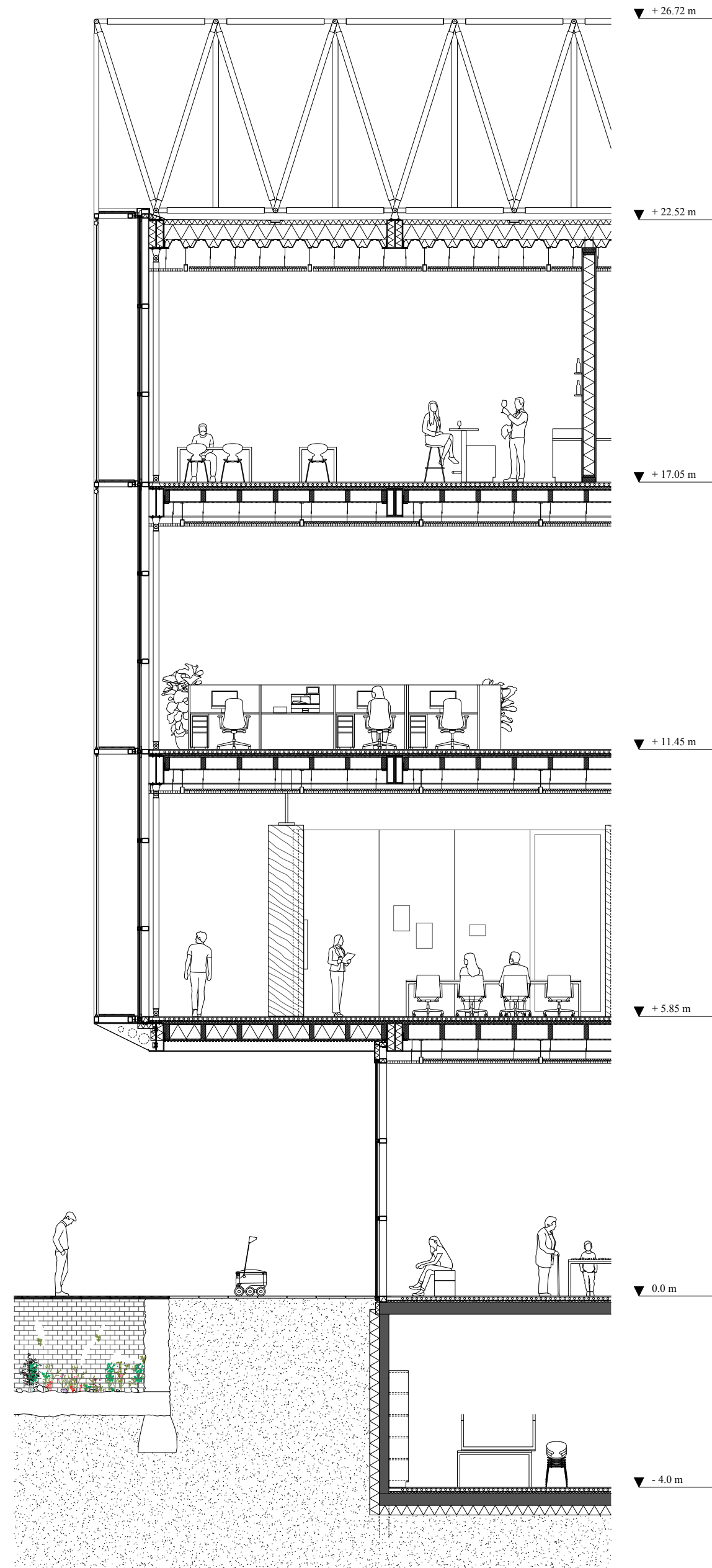
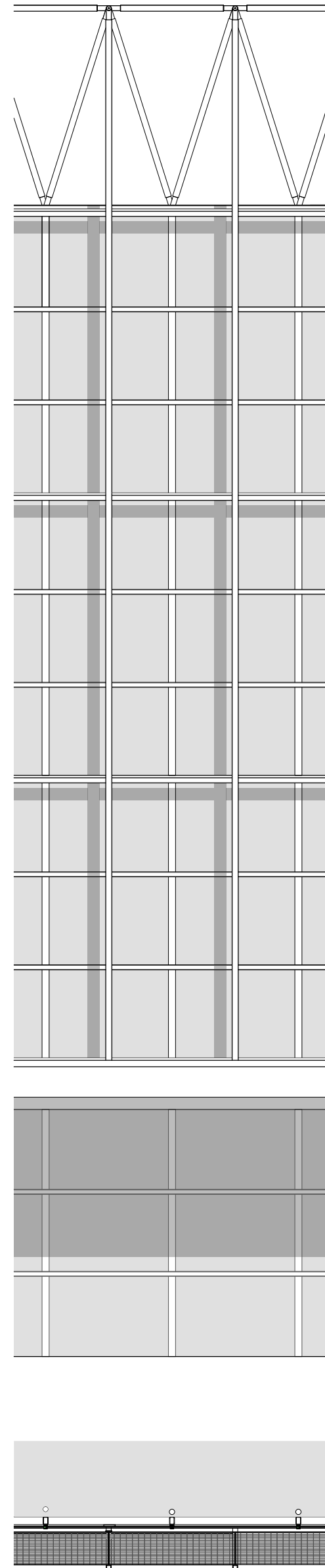

FORUM

1:50

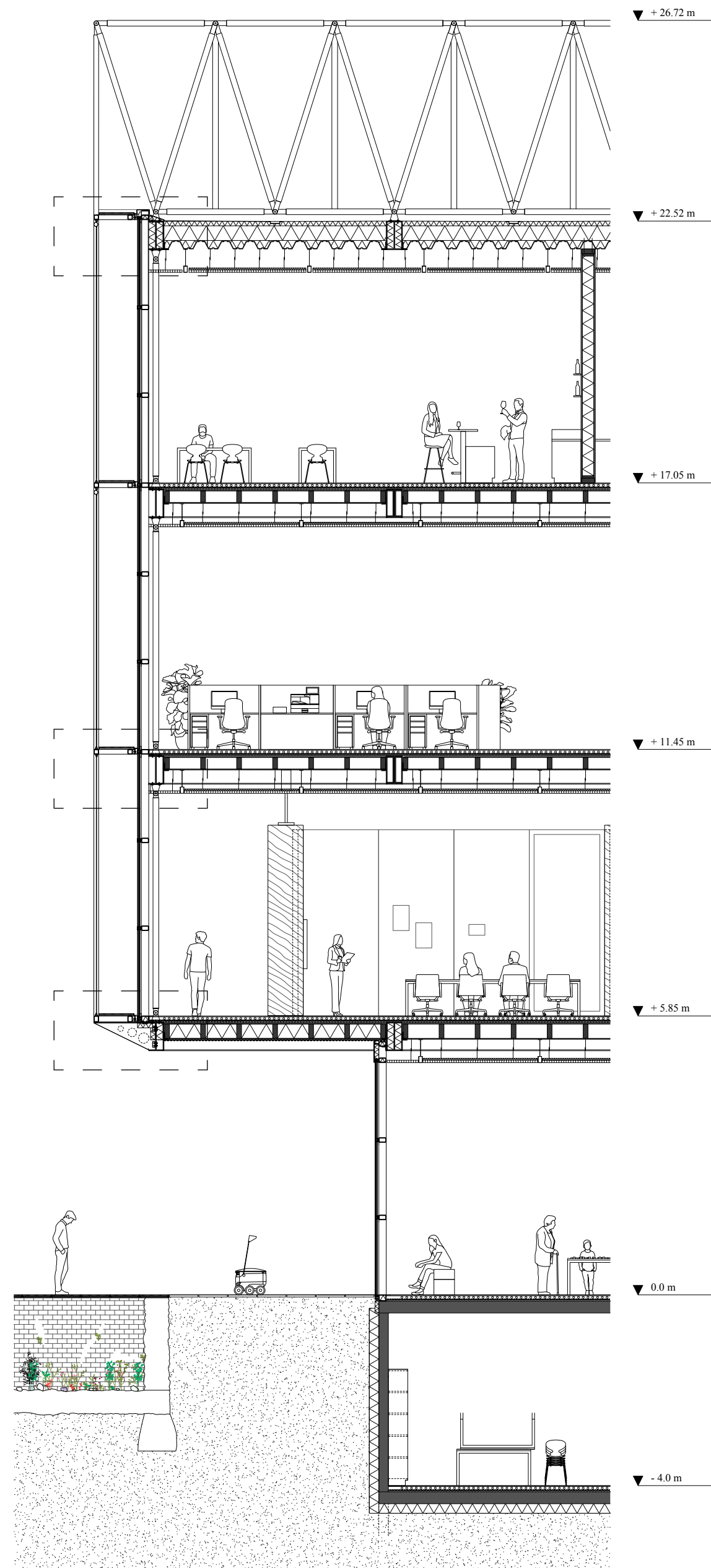
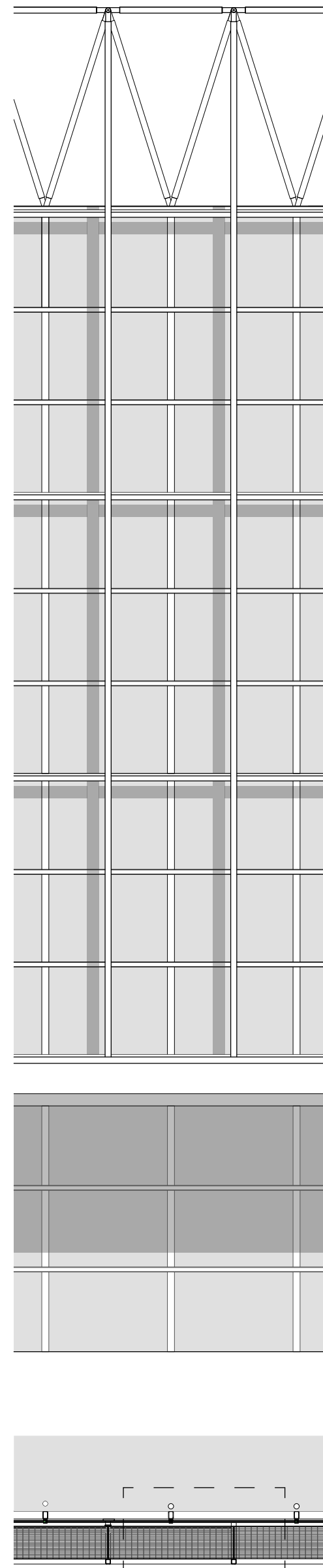

FORUM

1:5

First floor

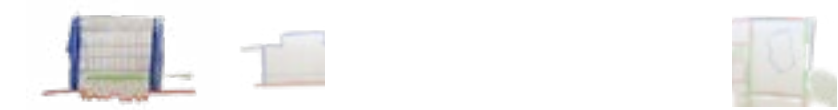
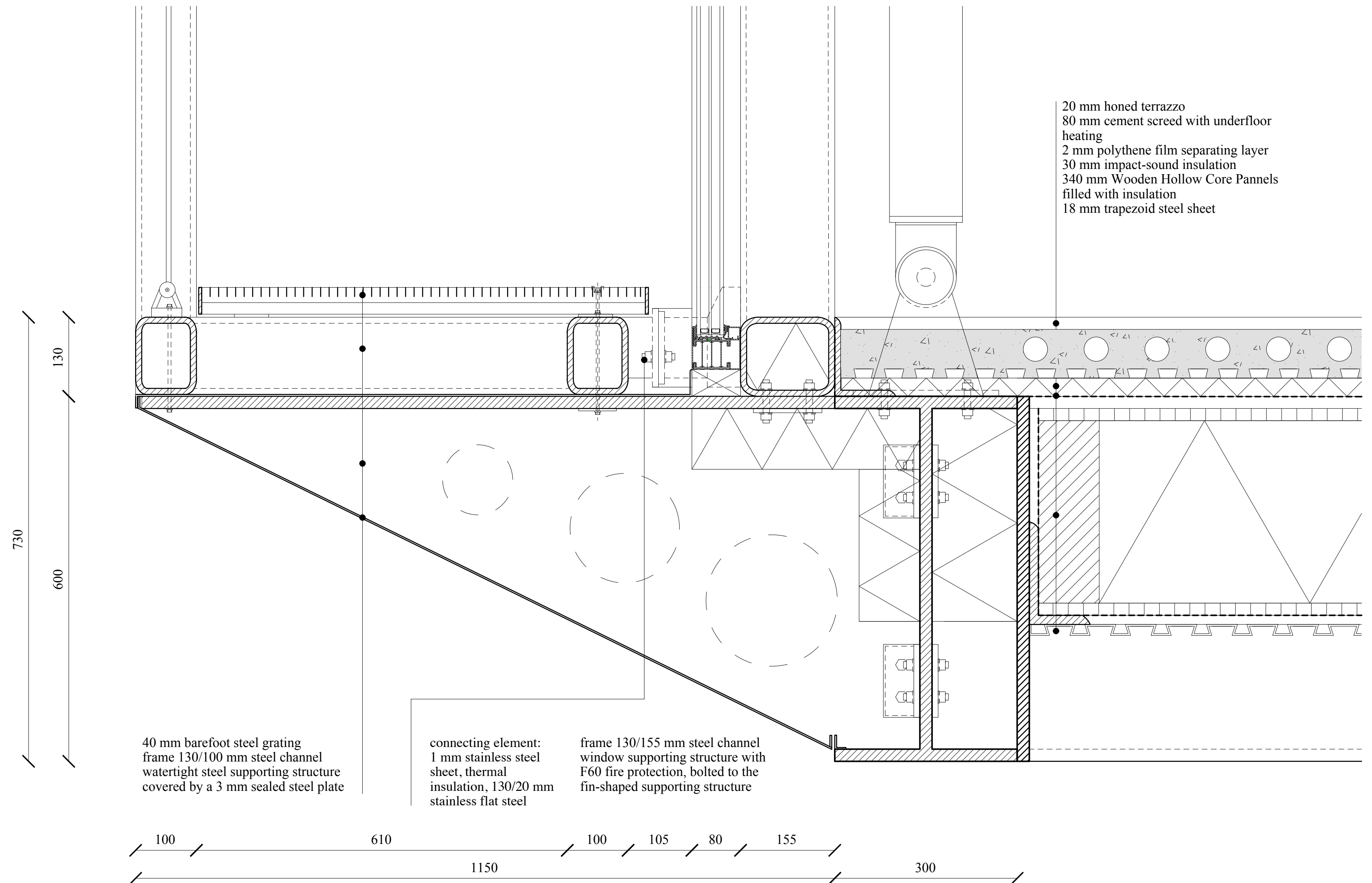

FORUM

1:5

First floor

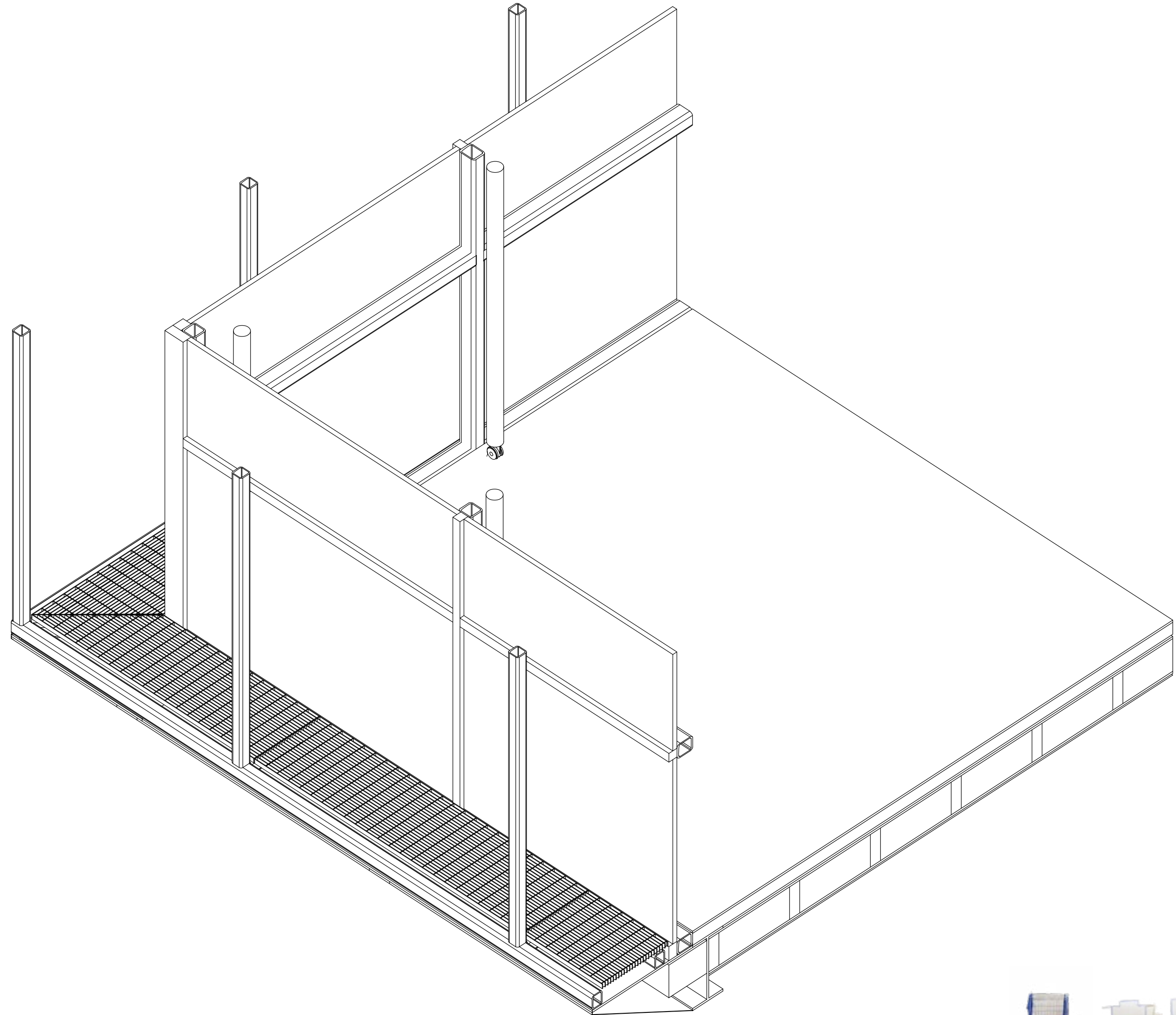

FORUM

1:5

First floor

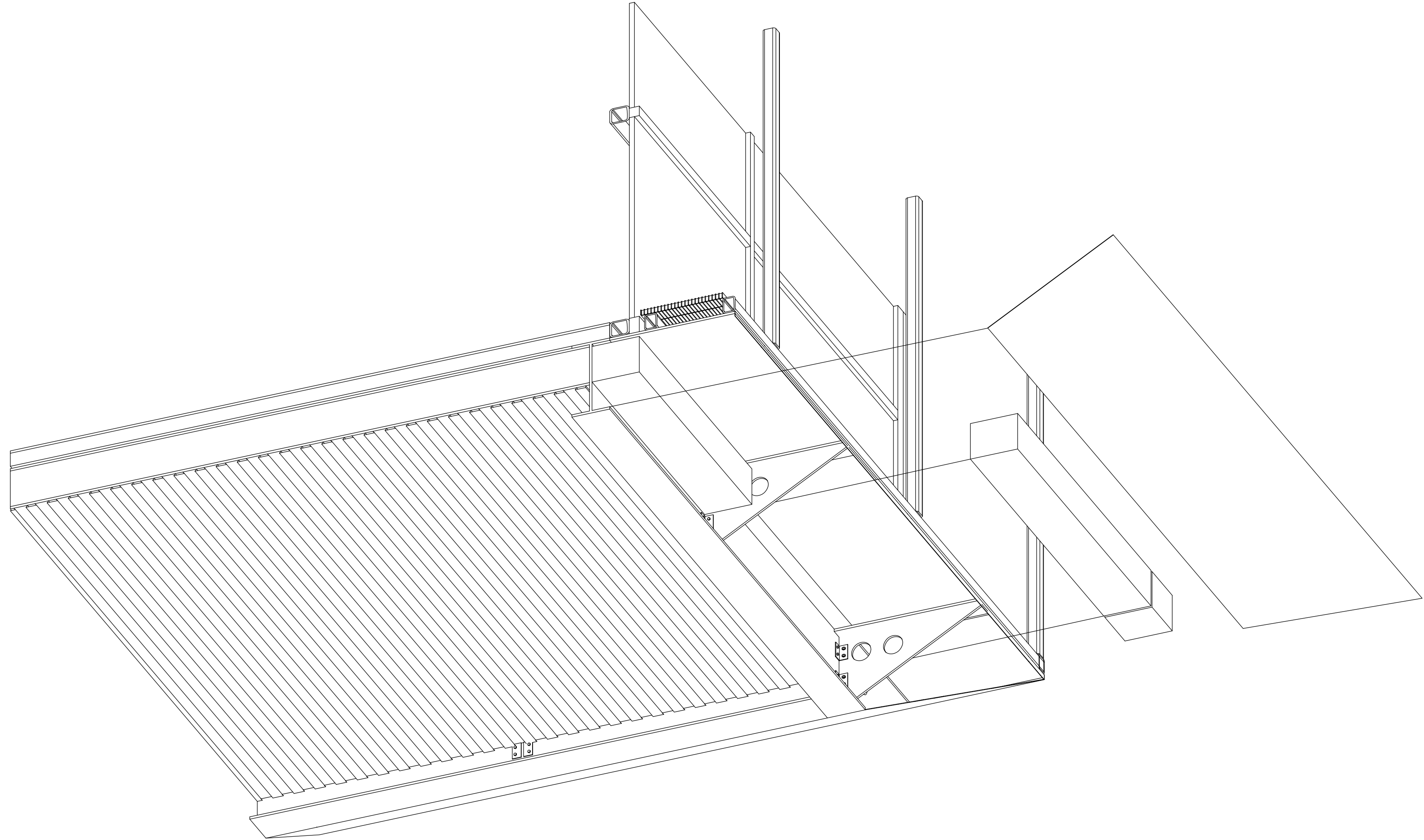

FORUM

1:5

Horizontal

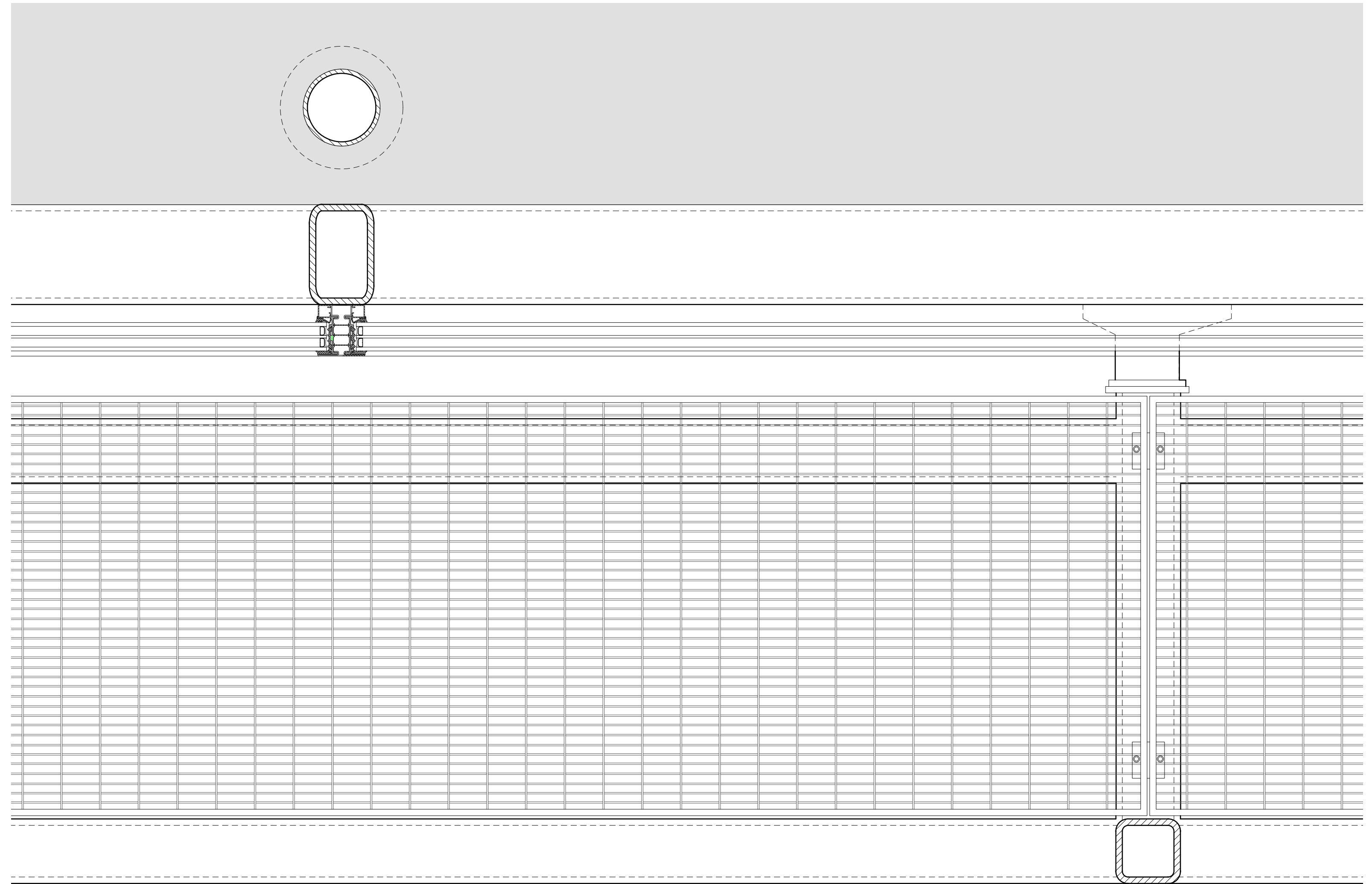

FORUM

1:5

Second and third floor

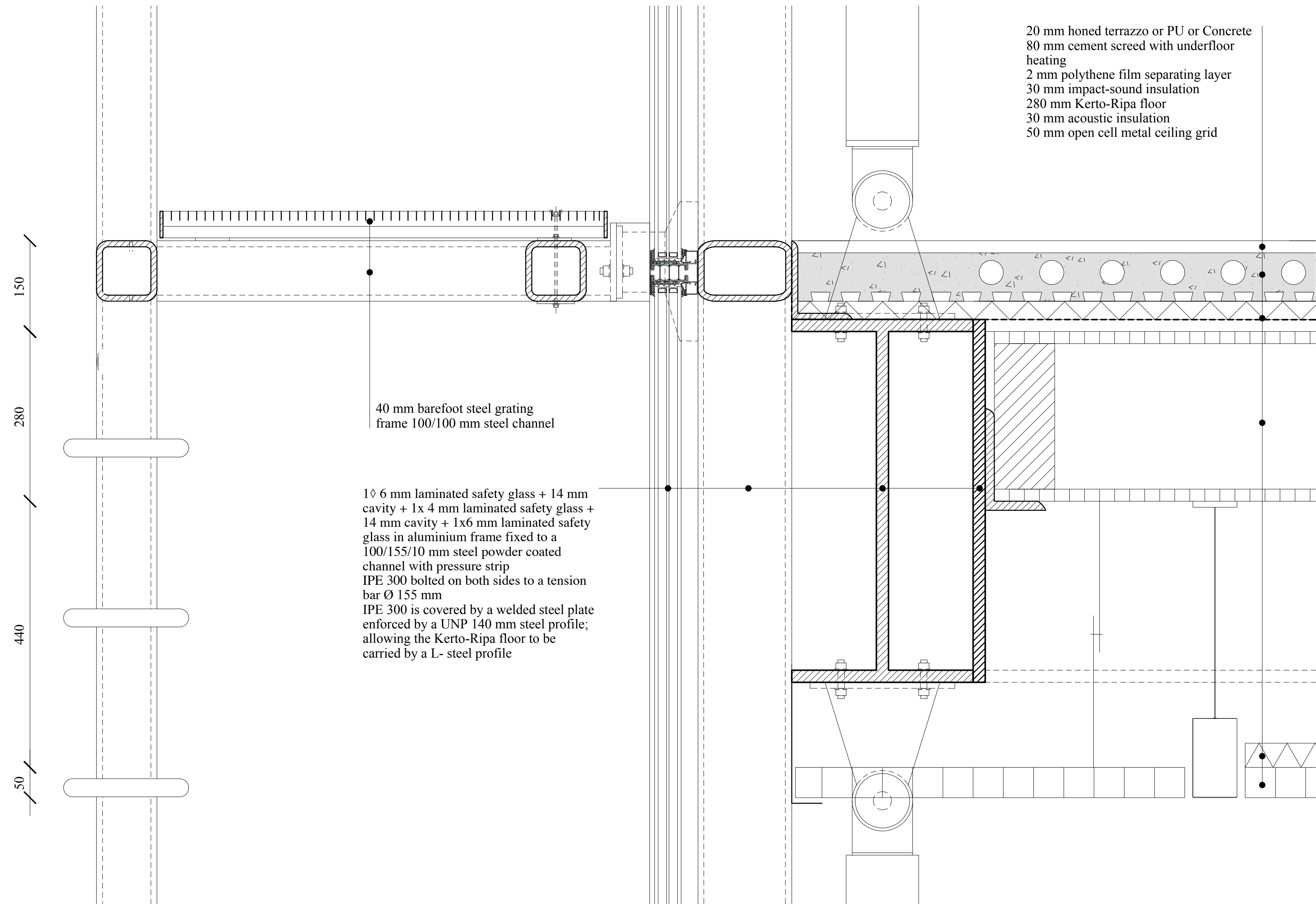

20 mm honed terrazzo or PU or Concrete
80 mm cement screed with underfloor heating
2 mm polythene film separating layer
30 mm impact-sound insulation
280 mm Kerto-Ripa floor
30 mm acoustic insulation
50 mm open cell metal ceiling grid

40 mm barefoot steel grating
frame 100/100 mm steel channel

1 diamond 6 mm laminated safety glass + 14 mm
cavity + 1 x 4 mm laminated safety glass +
14 mm cavity + 1 x 6 mm laminated safety
glass in aluminium frame fixed to a
100/155/10 mm steel powder coated
channel with pressure strip
IPE 300 bolted on both sides to a tension
bar Ø 155 mm
IPE 300 is covered by a welded steel plate
enforced by a UNP 140 mm steel profile;
allowing the Kerto-Ripa floor to be
carried by a L- steel profile



FORUM

1:5

Second and third floor

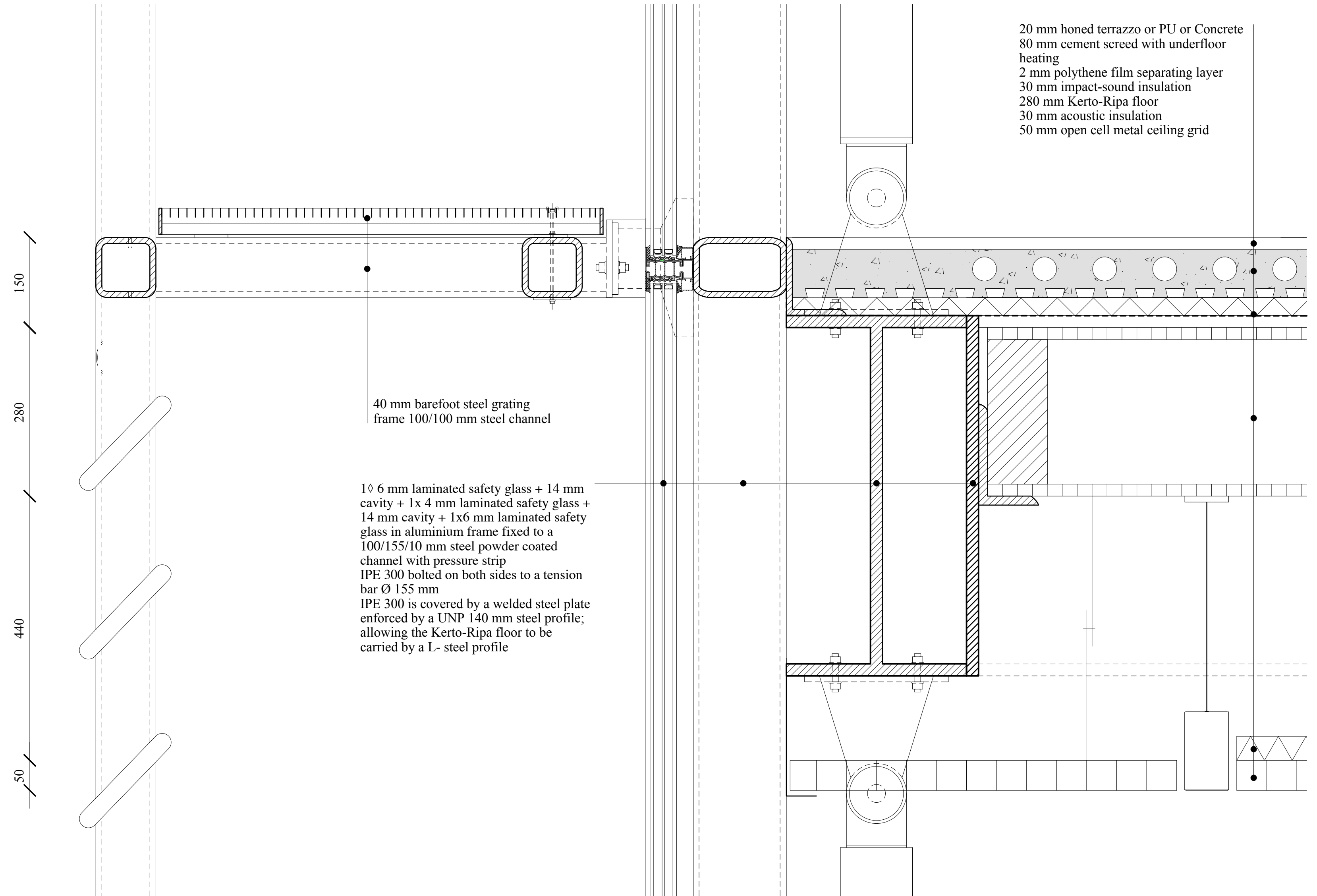

FORUM



FORUM

1:5

Roof

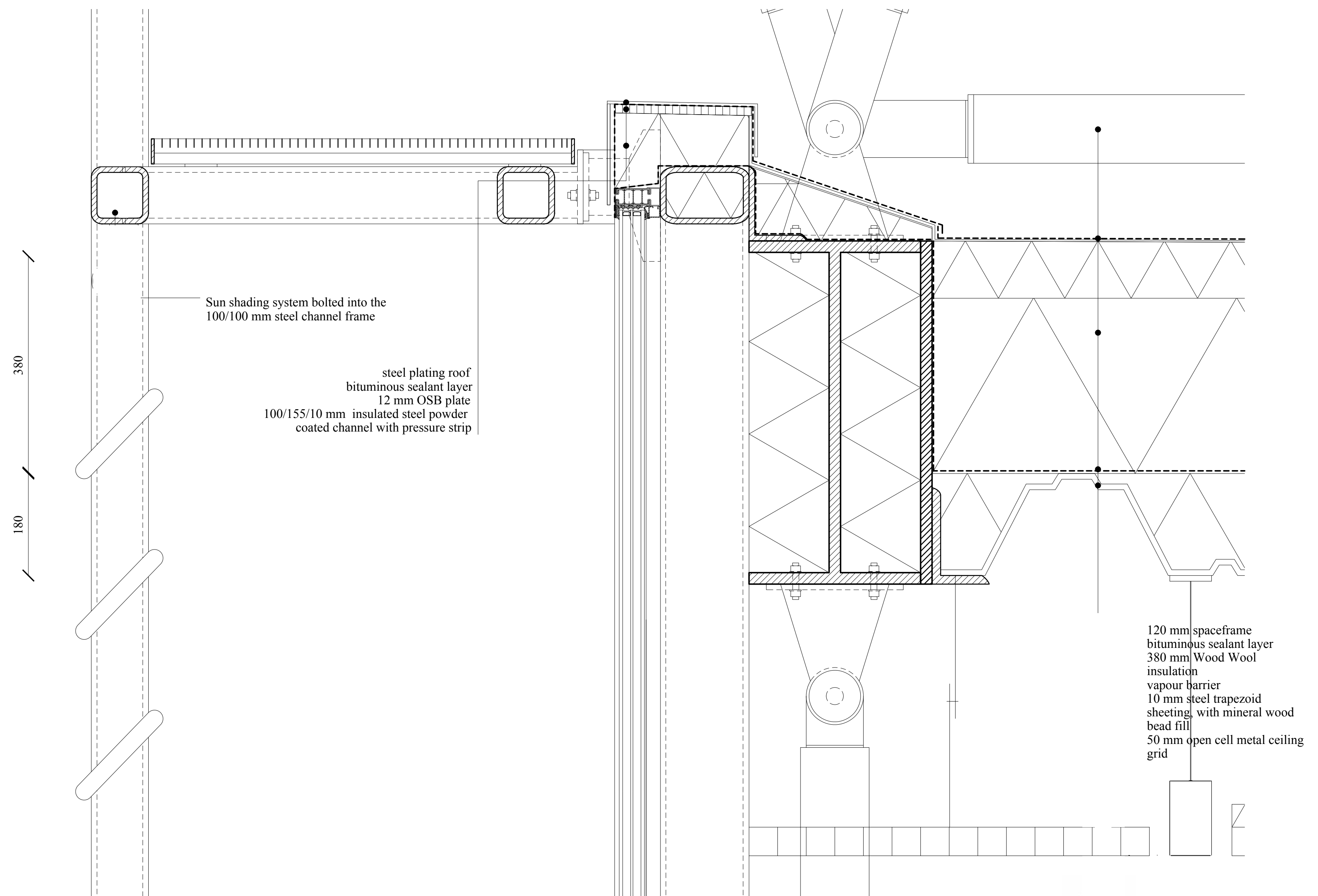

Sun shading system bolted into the 100/100 mm steel channel frame

steel plating roof
bituminous sealant layer
12 mm OSB plate
100/155/10 mm insulated steel powder coated channel with pressure strip

120 mm spaceframe
bituminous sealant layer
380 mm Wood Wool insulation
vapour barrier
10 mm steel trapezoid sheeting, with mineral wood bead fill
50 mm open cell metal ceiling grid



MUNICIPALITY



MUNICIPALITY



MUNICIPALITY

1:50



SPORTSFACILITY



SPORTSFACILITY

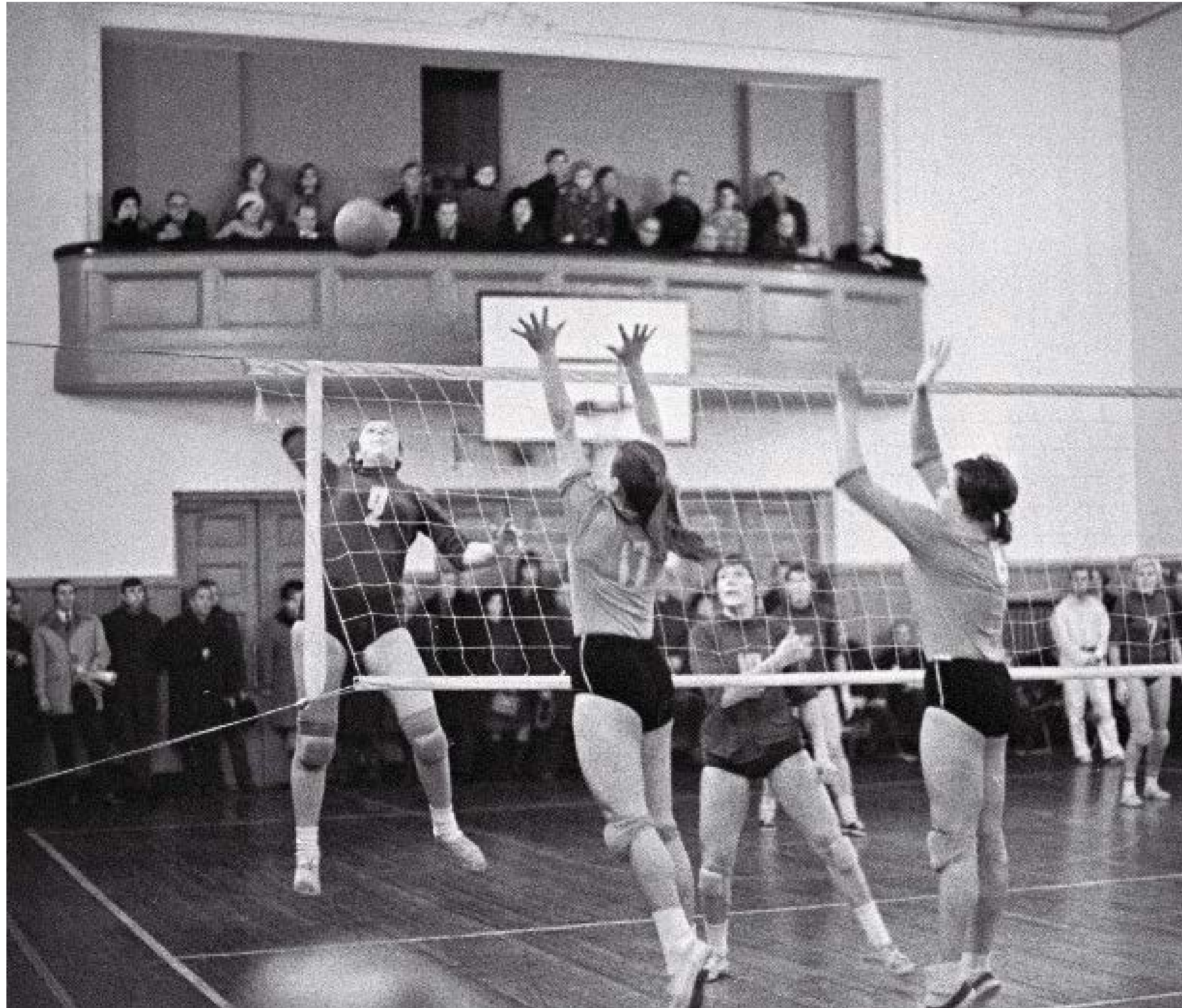

Volleyball competition between Tallinn and Riga in 1971

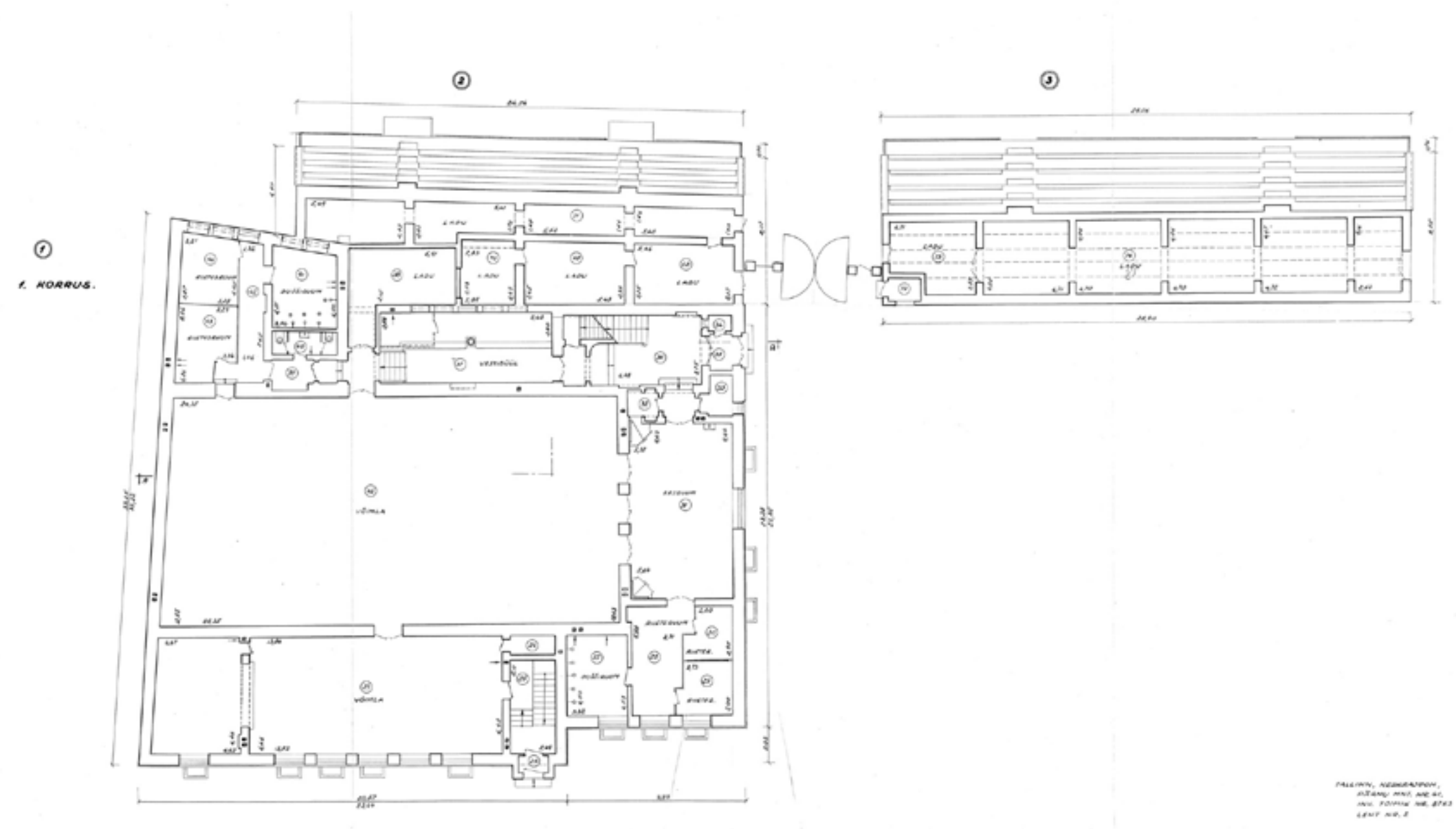

Ground floor

DEMOLITION

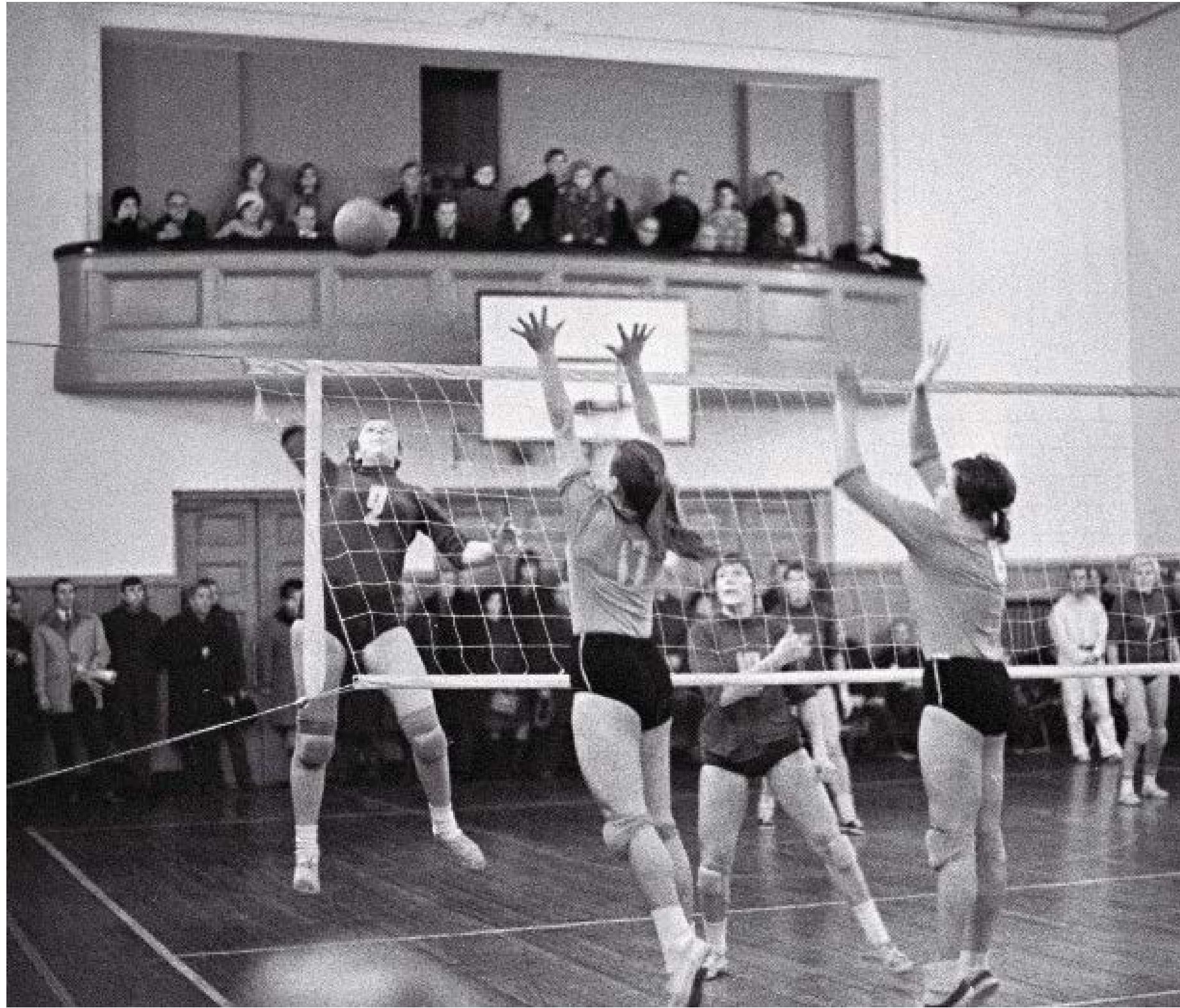

Volleyball competition between Tallinn and Riga in 1971

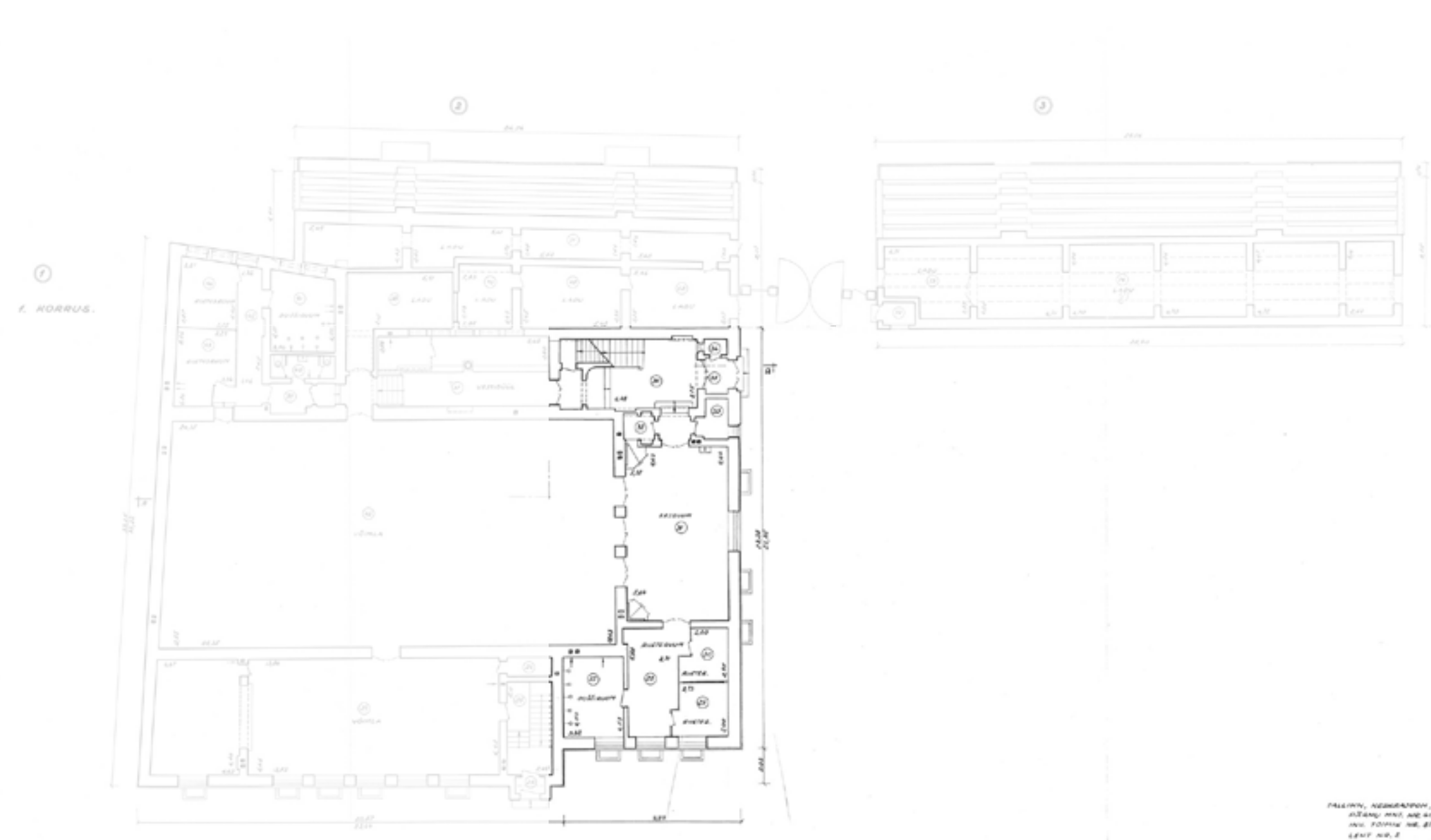

Ground floor

MUNICIPALITY



MUNICIPALITY

1:50
Ground Floor

- 1 Entrance visitors
- 2 Front desk //retrieving information
- 3 Employee desk
- 4 Opinion booth
- 5 Waiting area
- 6 Municipality announcements
- 7 Entrance employees / cafe
- 8 Cafe

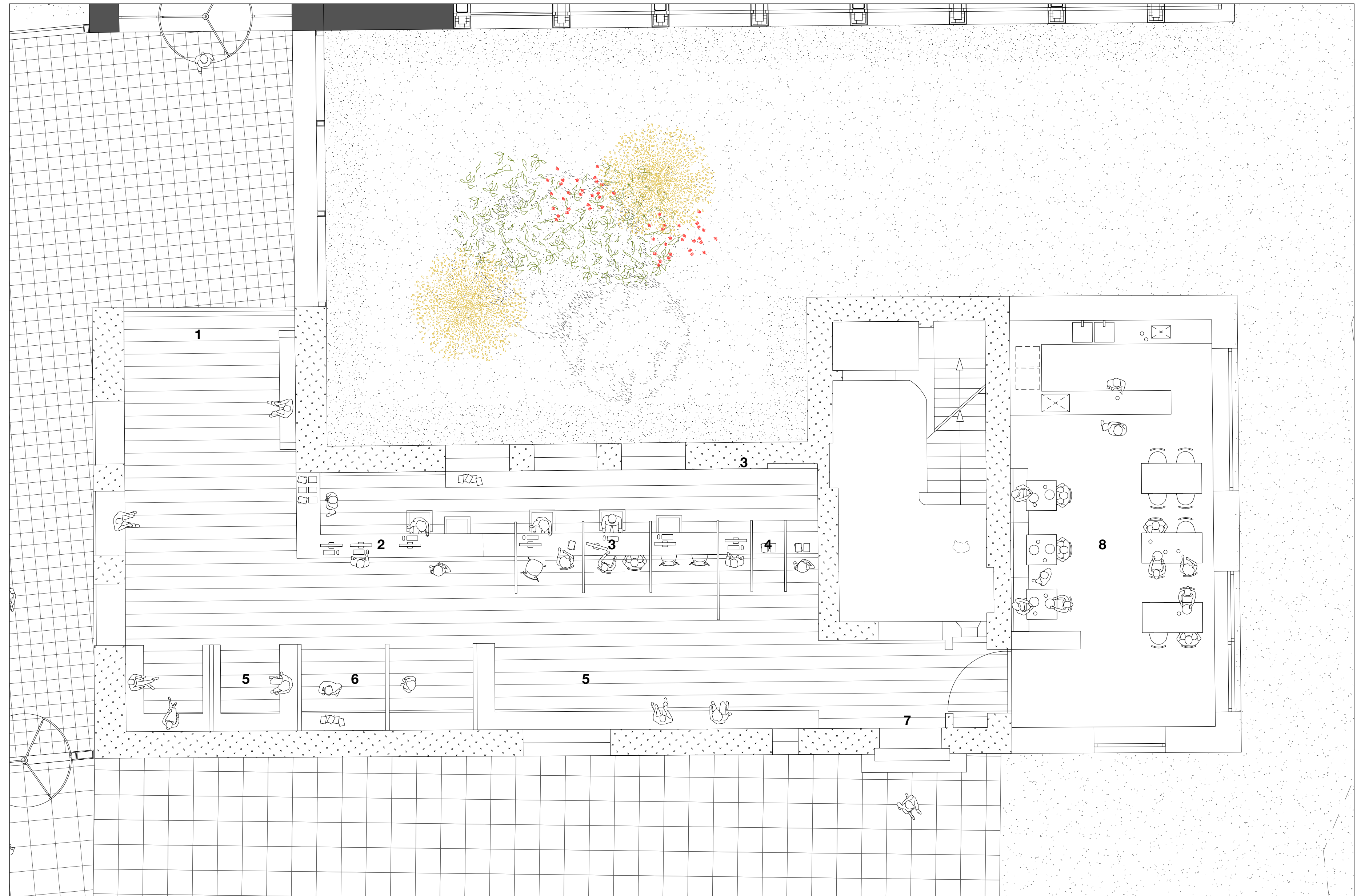



MUNICIPALITY

1:50

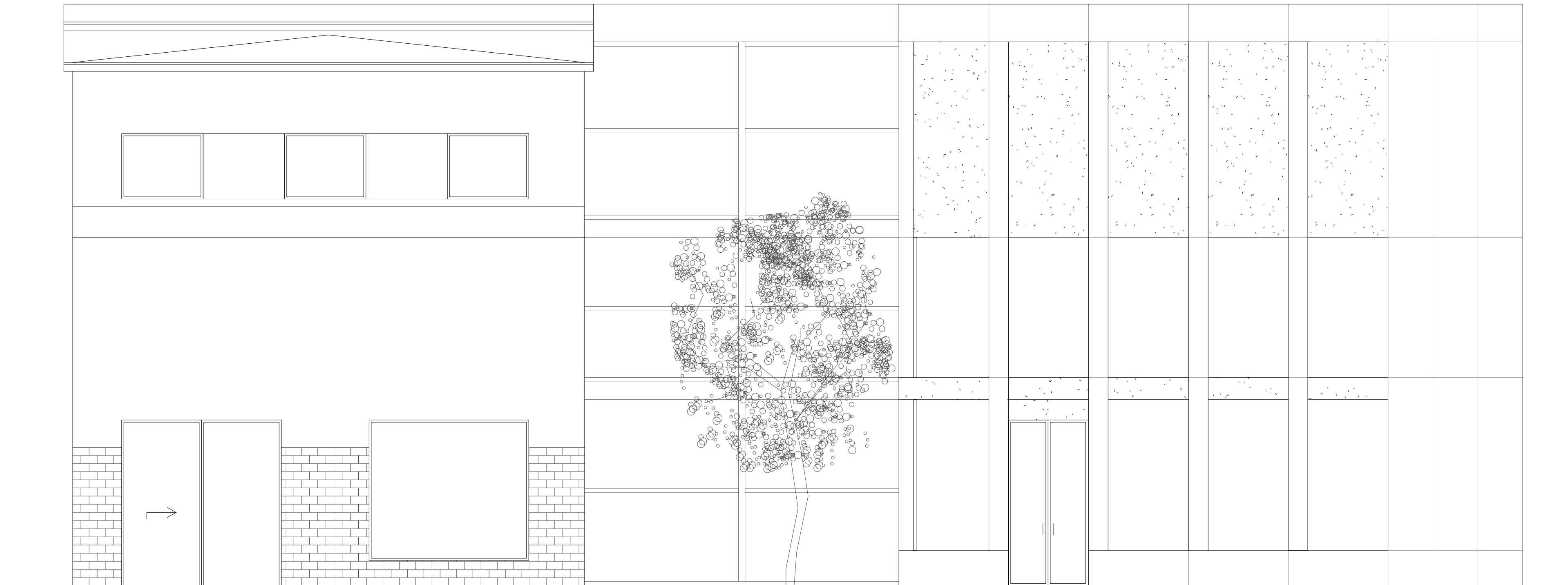

MUNICIPALITY

1:50
First Floor

- 1 Entrance visitors
- 2 Toilet
- 3 Cantine
- 4 Meeting room
- 5 Offices
- 6 Cafe

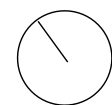
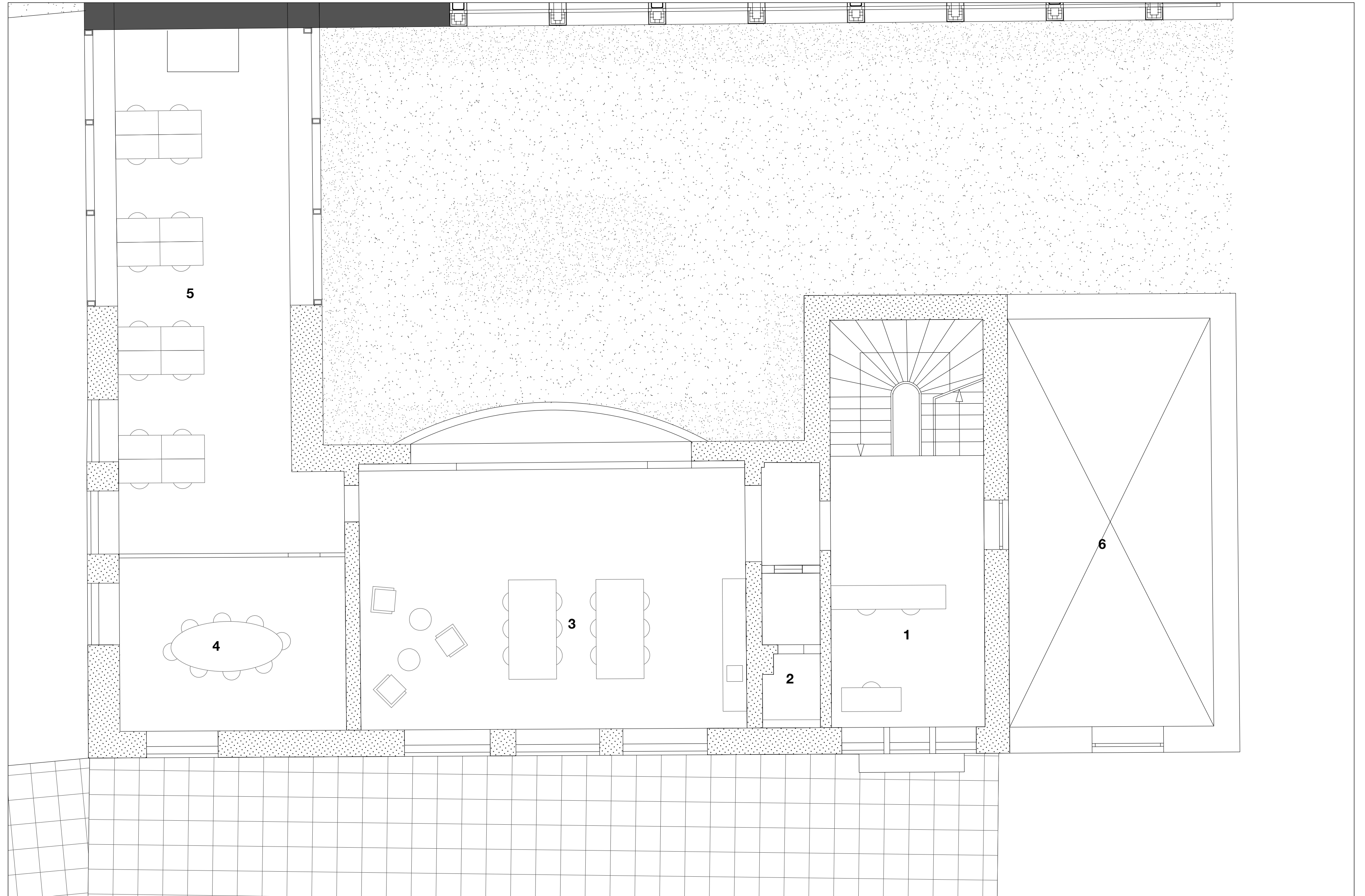

MUNICIPALITY

1:50
Second Floor

- 1 Seating area
- 2 Toilet
- 3 Offices
- 4 Meeting room
- 6 Small auditorium

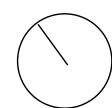
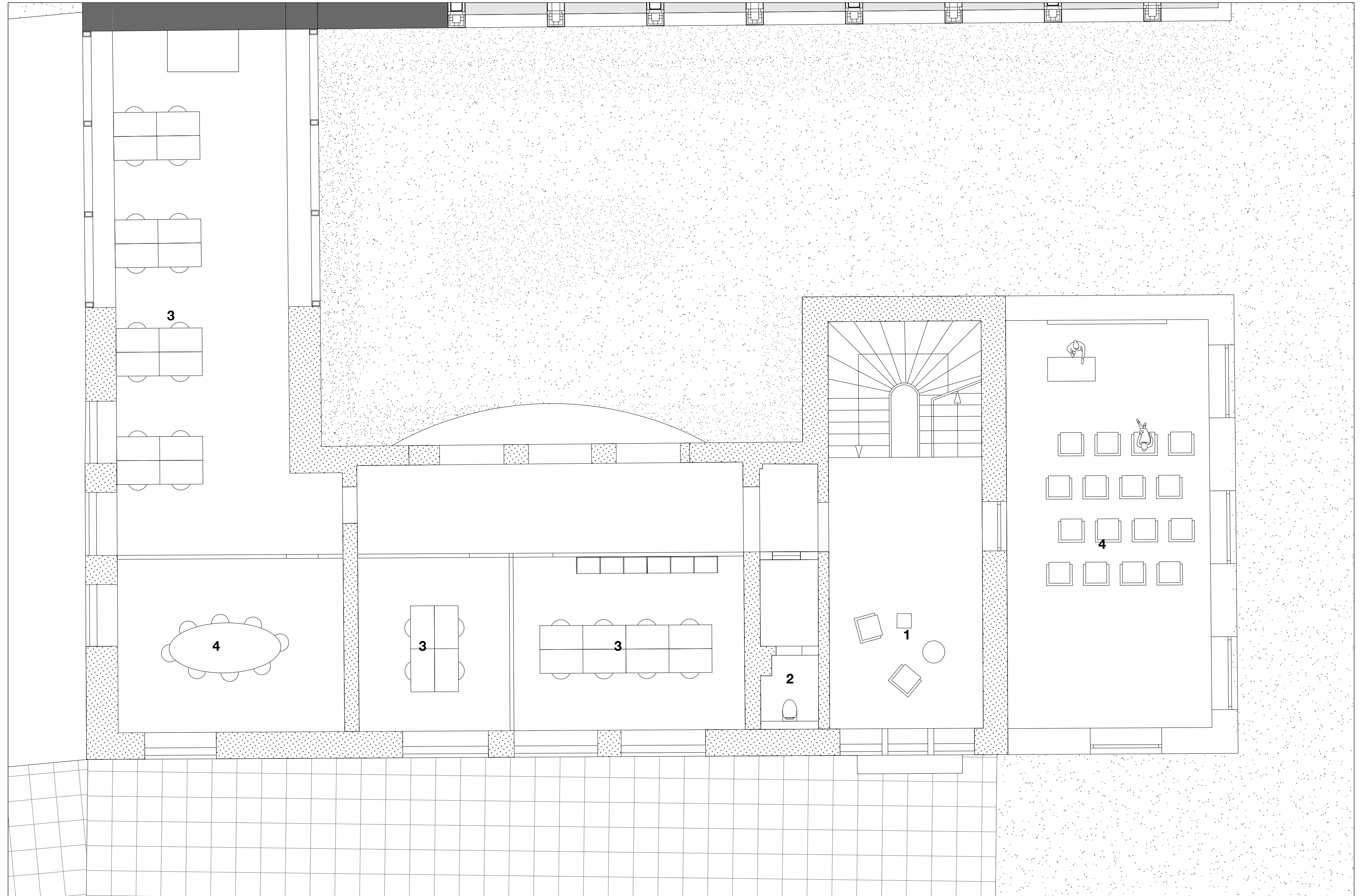

ARCHIVE





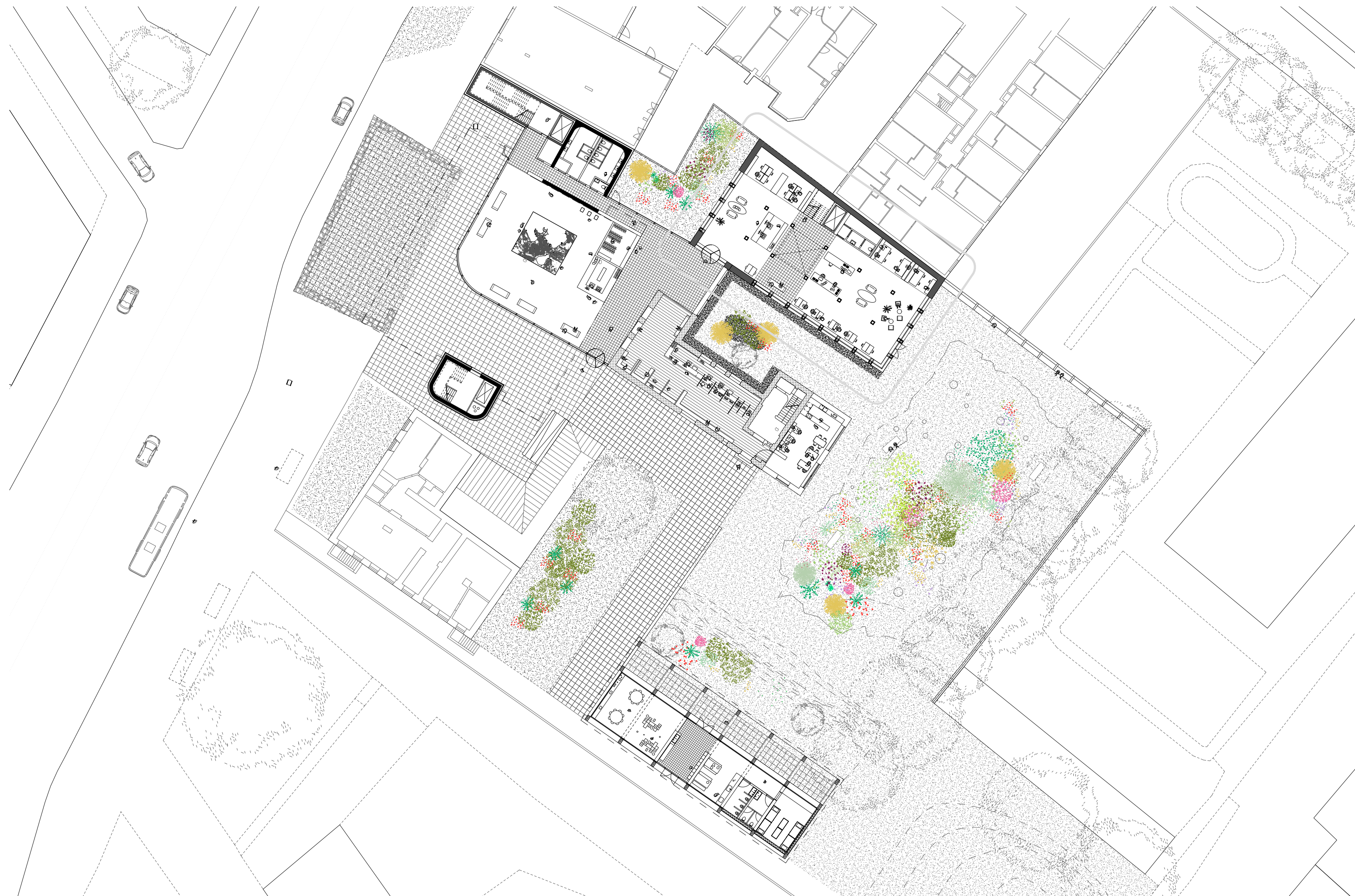

ARCHIVE

1:50

Facade

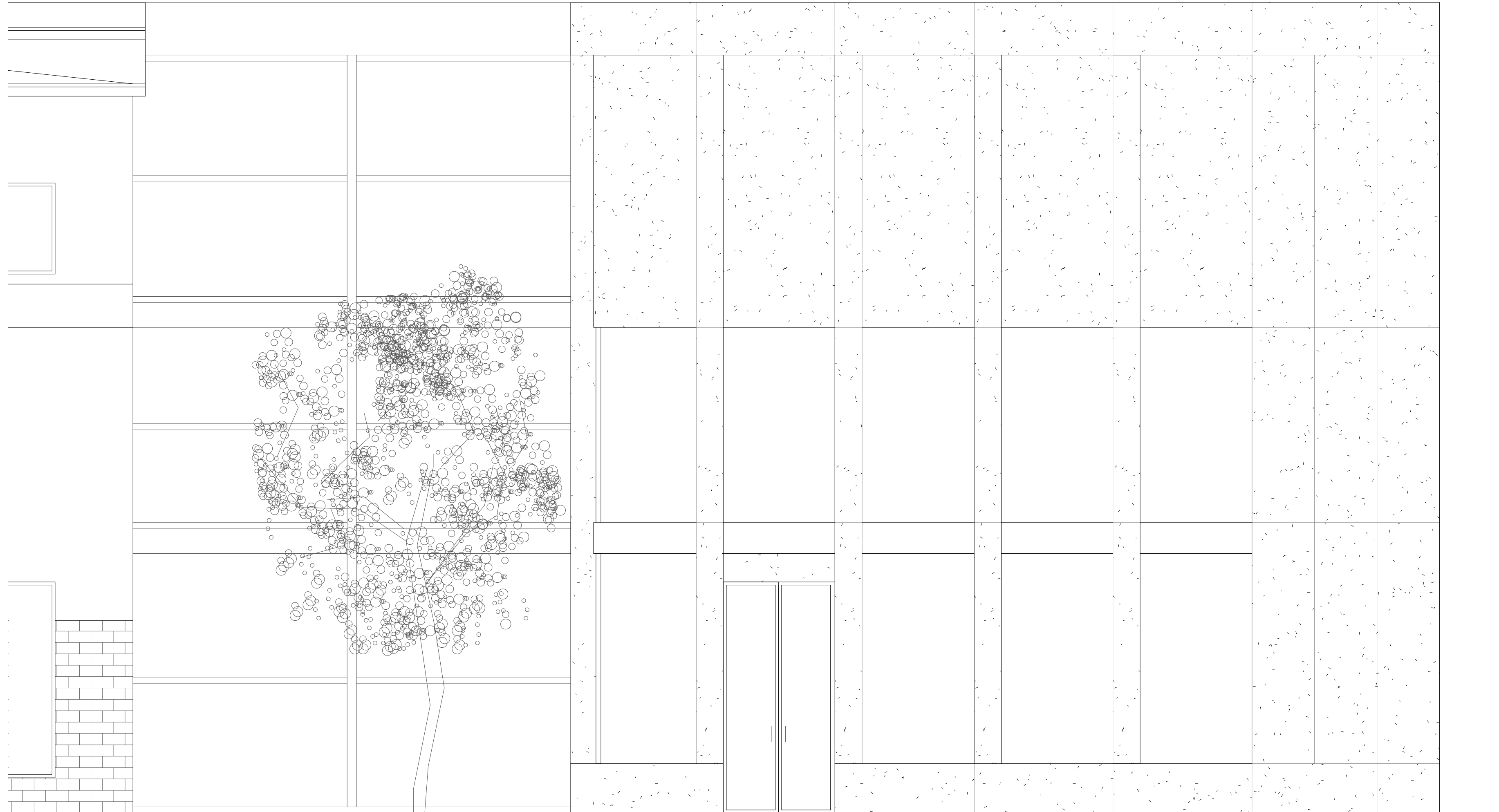

ARCHIVE

1:50

Section

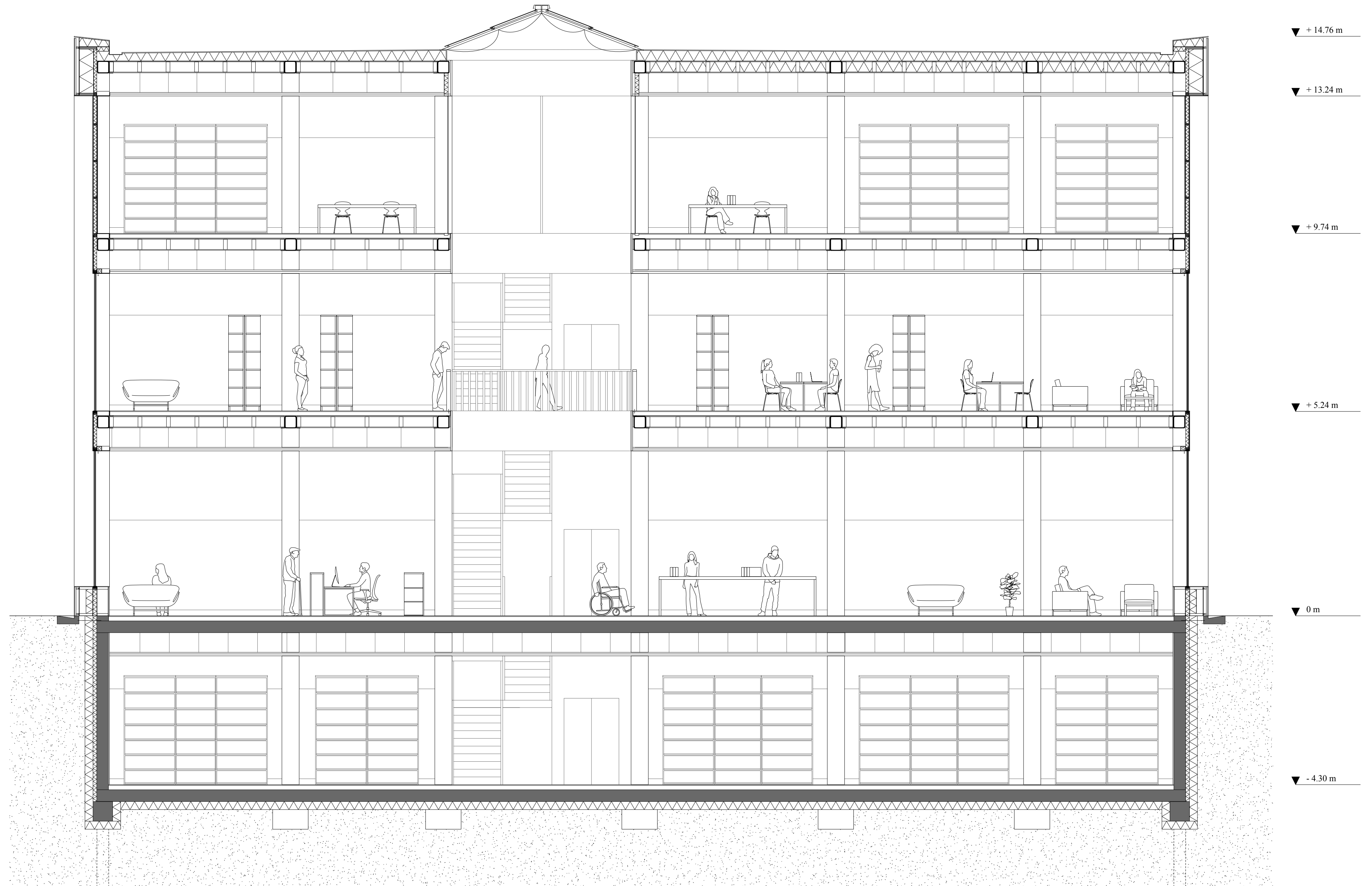

ARCHIVE

1:50
Ground Floor

- 1 Entrance
- 2 Front desk
- 3 Archival viewing table
- 4 Study zone 'talking allowed'
- 5 Lounge area
- 6 Deep concentration
- 7 Toilet
- 8 Technical space

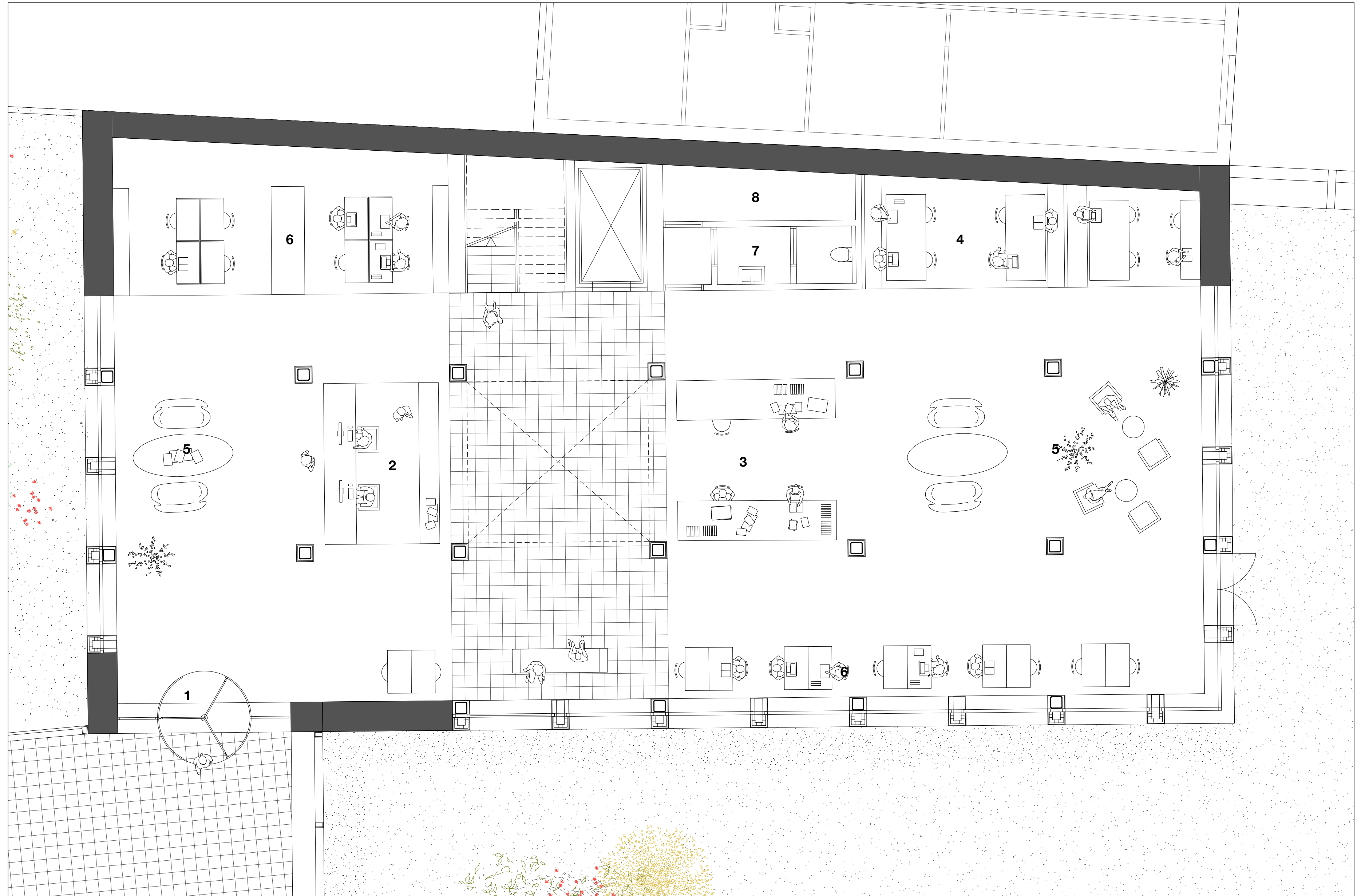

ARCHIVE

1:50
Basement

- 1 Archival material
- 2 Archival viewing table
- 3 Technical space

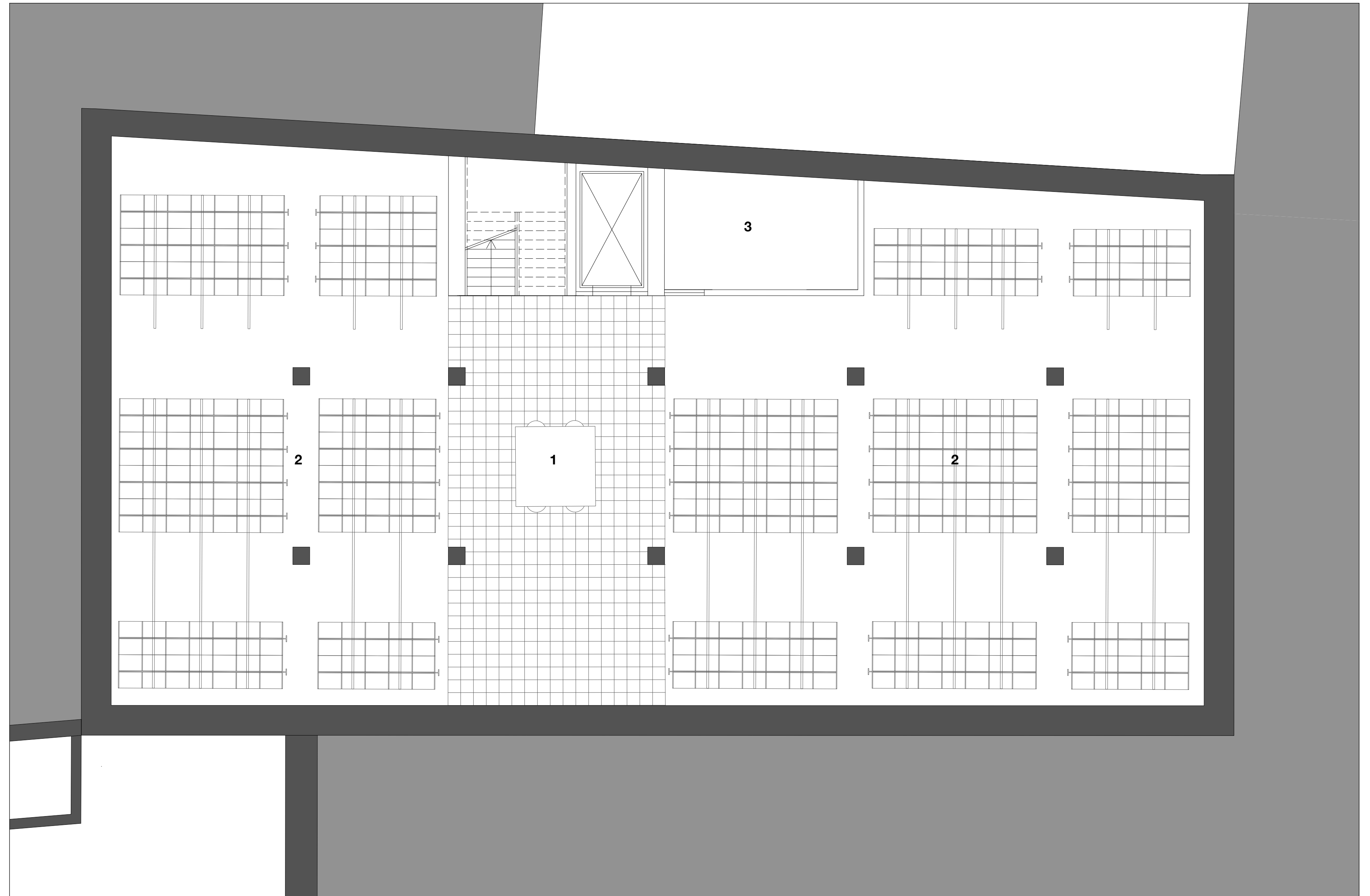

ARCHIVE

1:50
First Floor

- 1 Study zone 'talking allowed'
- 2 Lounge area
- 3 Deep concentration
- 4 Toilet
- 5 Technical space

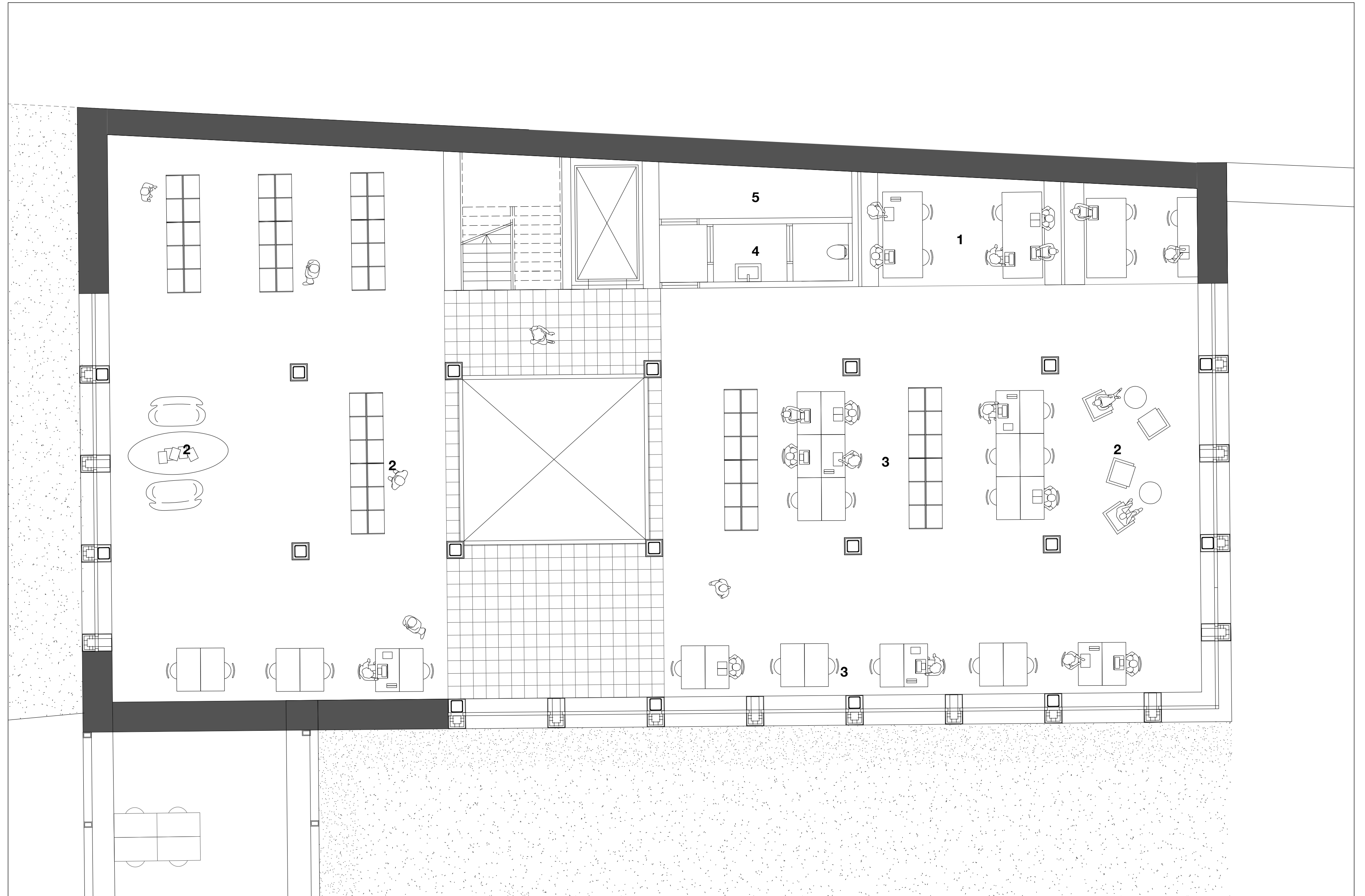

ARCHIVE

1:50
Second Floor

- 1 Archival viewing table
- 2 Archival material
- 3 Technical space

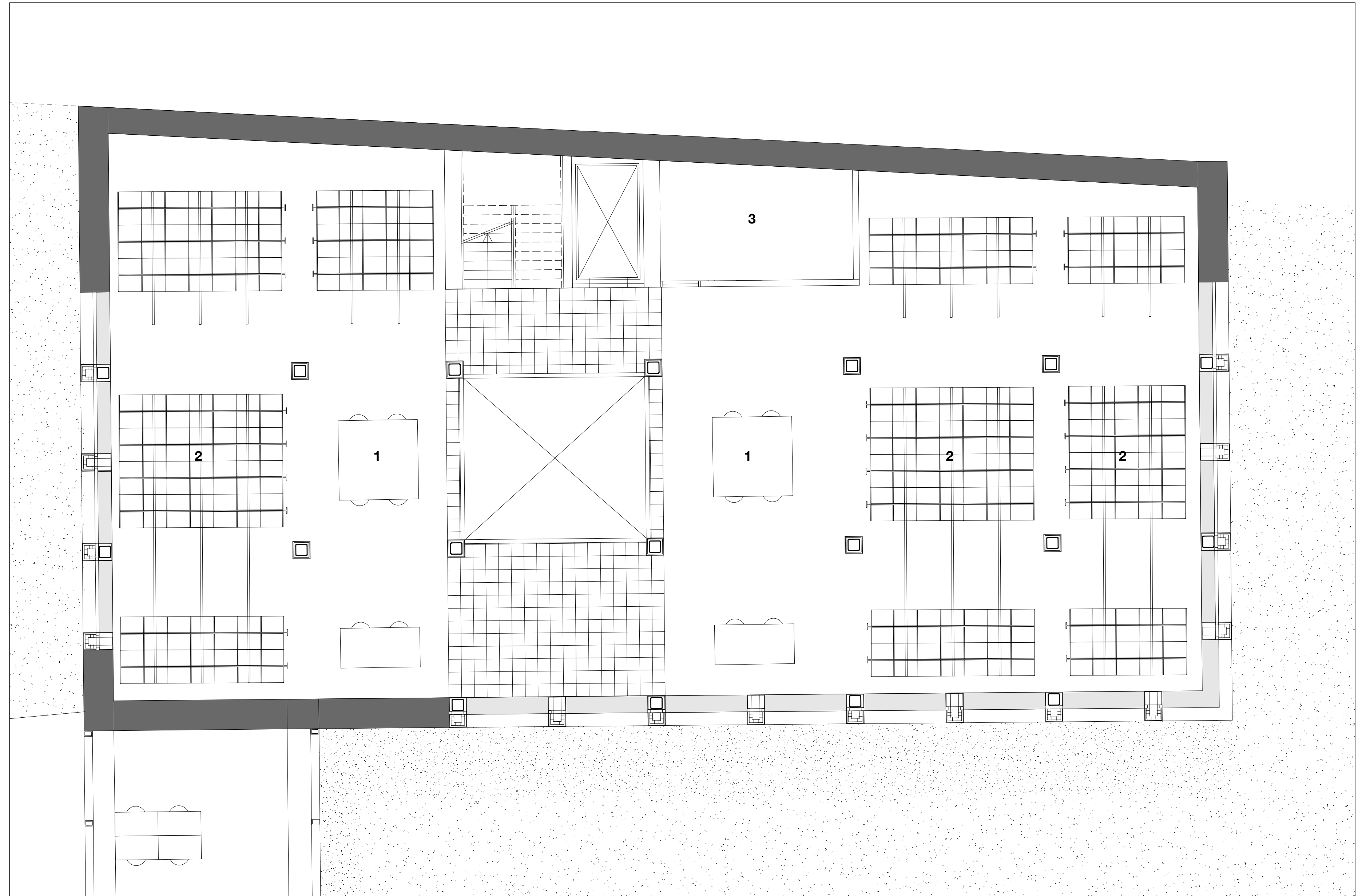

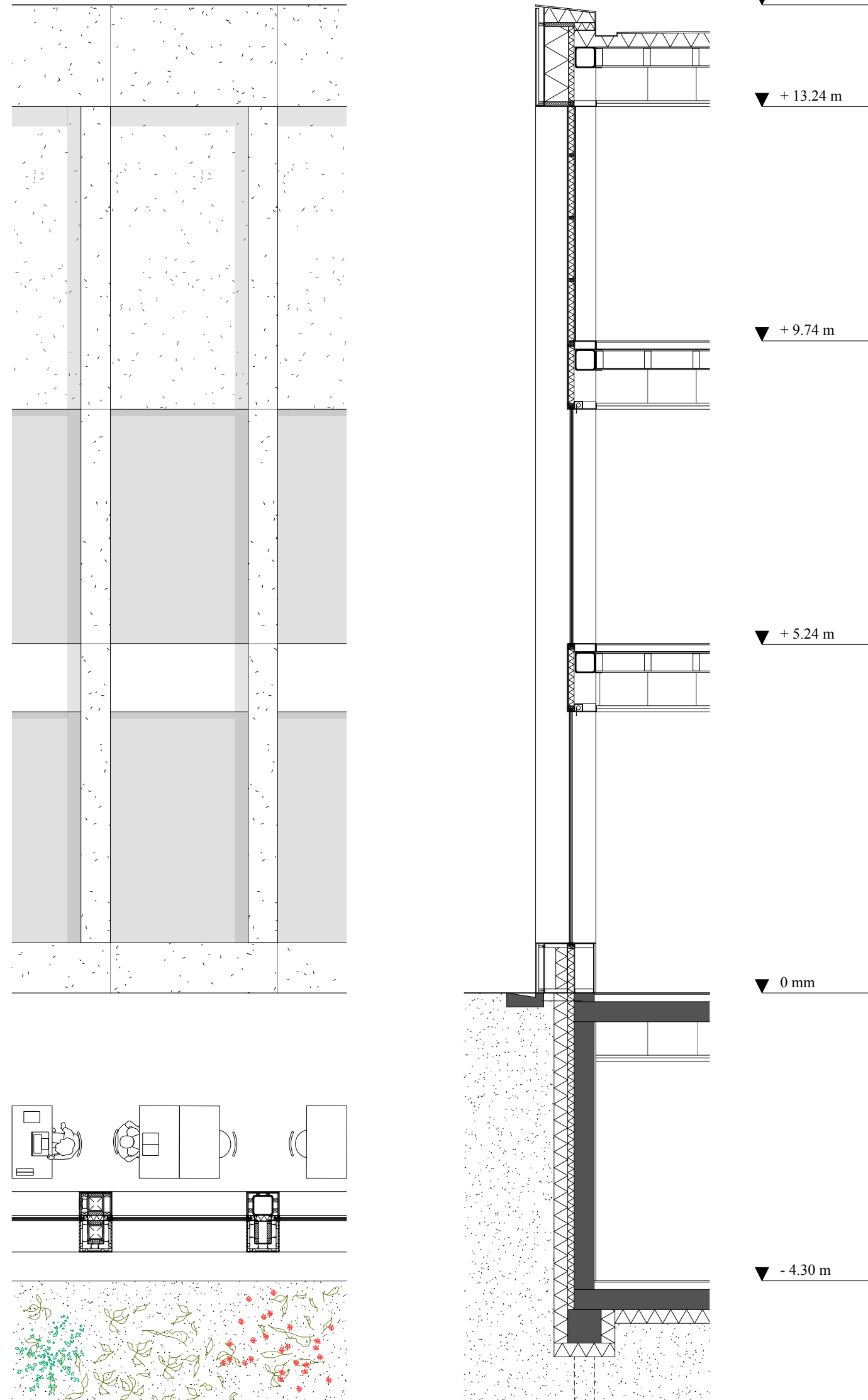

ARCHIVE

1:5

Connection ground

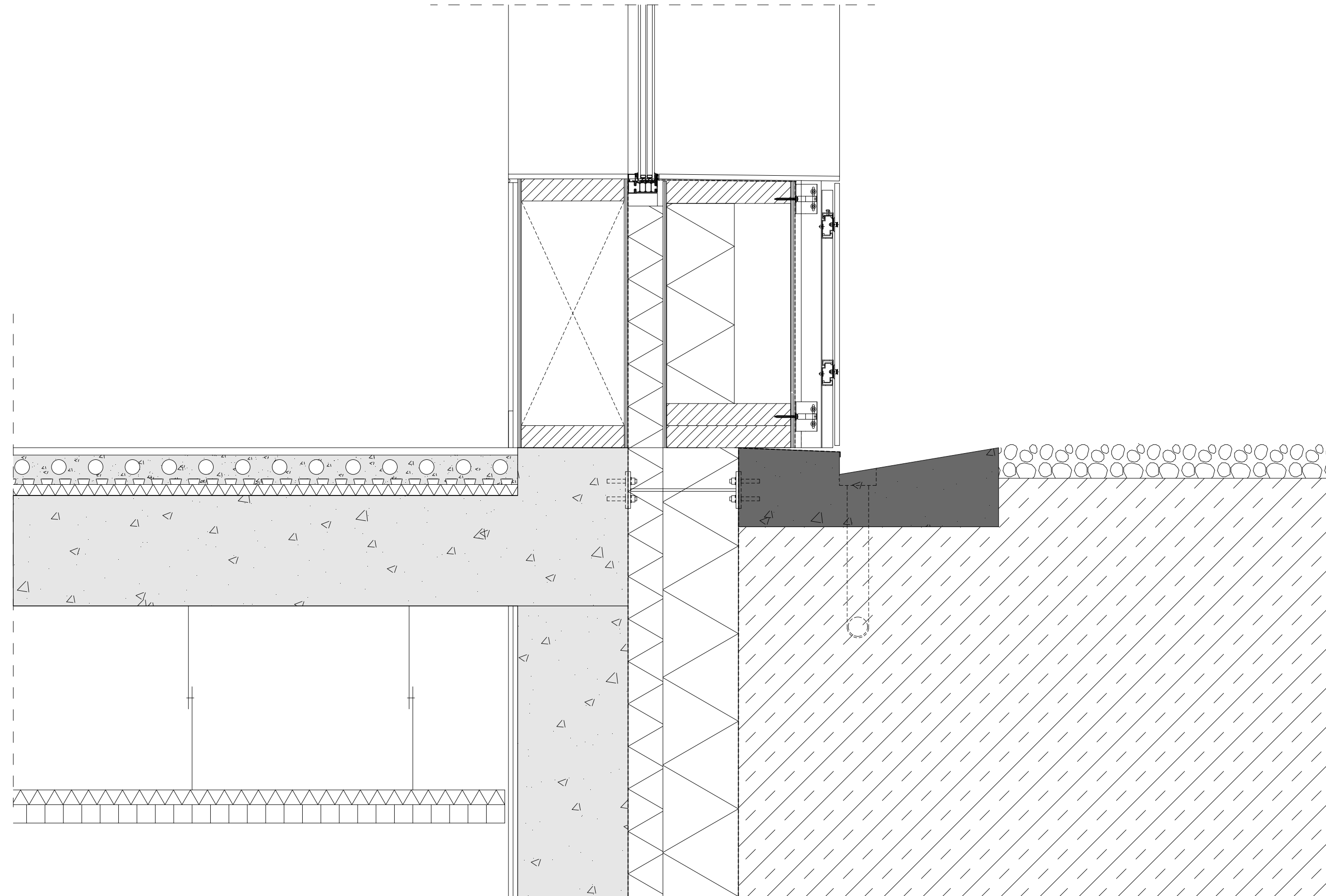

ARCHIVE

1:5

Ventilation principle

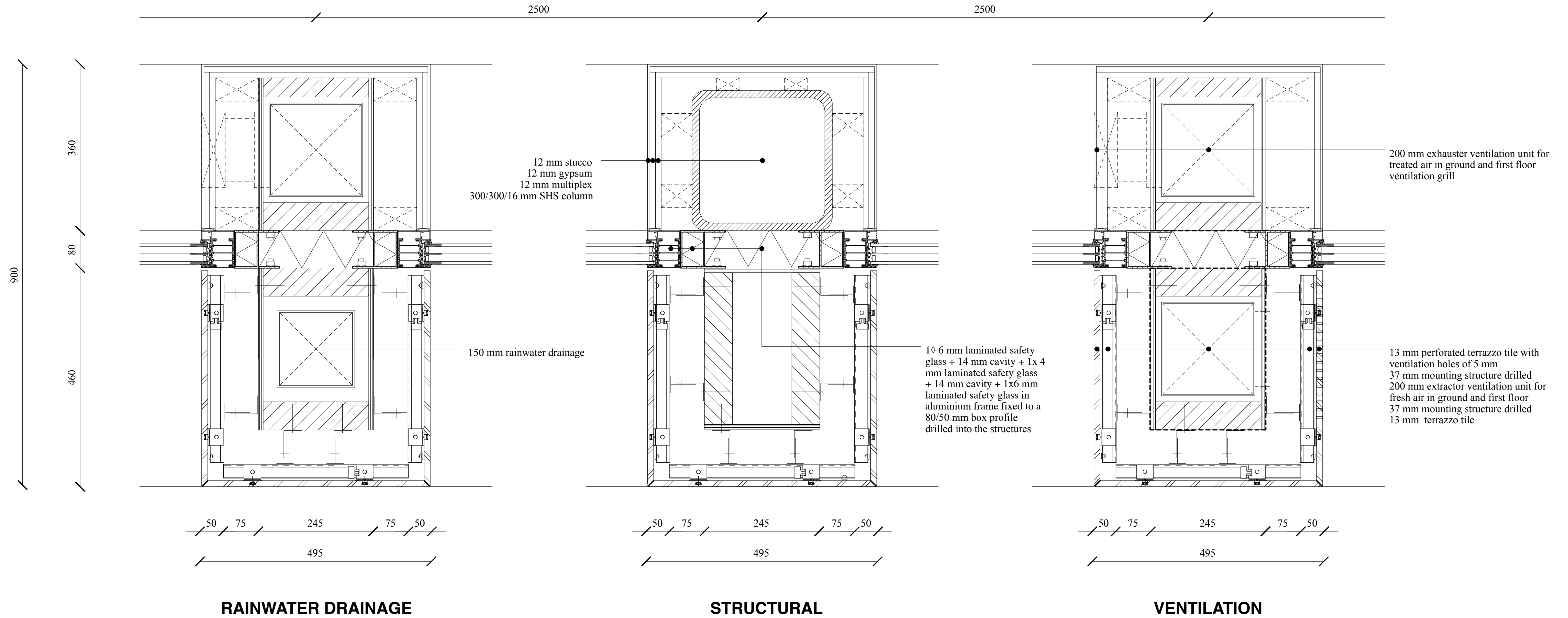

ARCHIVE

1:50
Ground floor

Ventilation principle

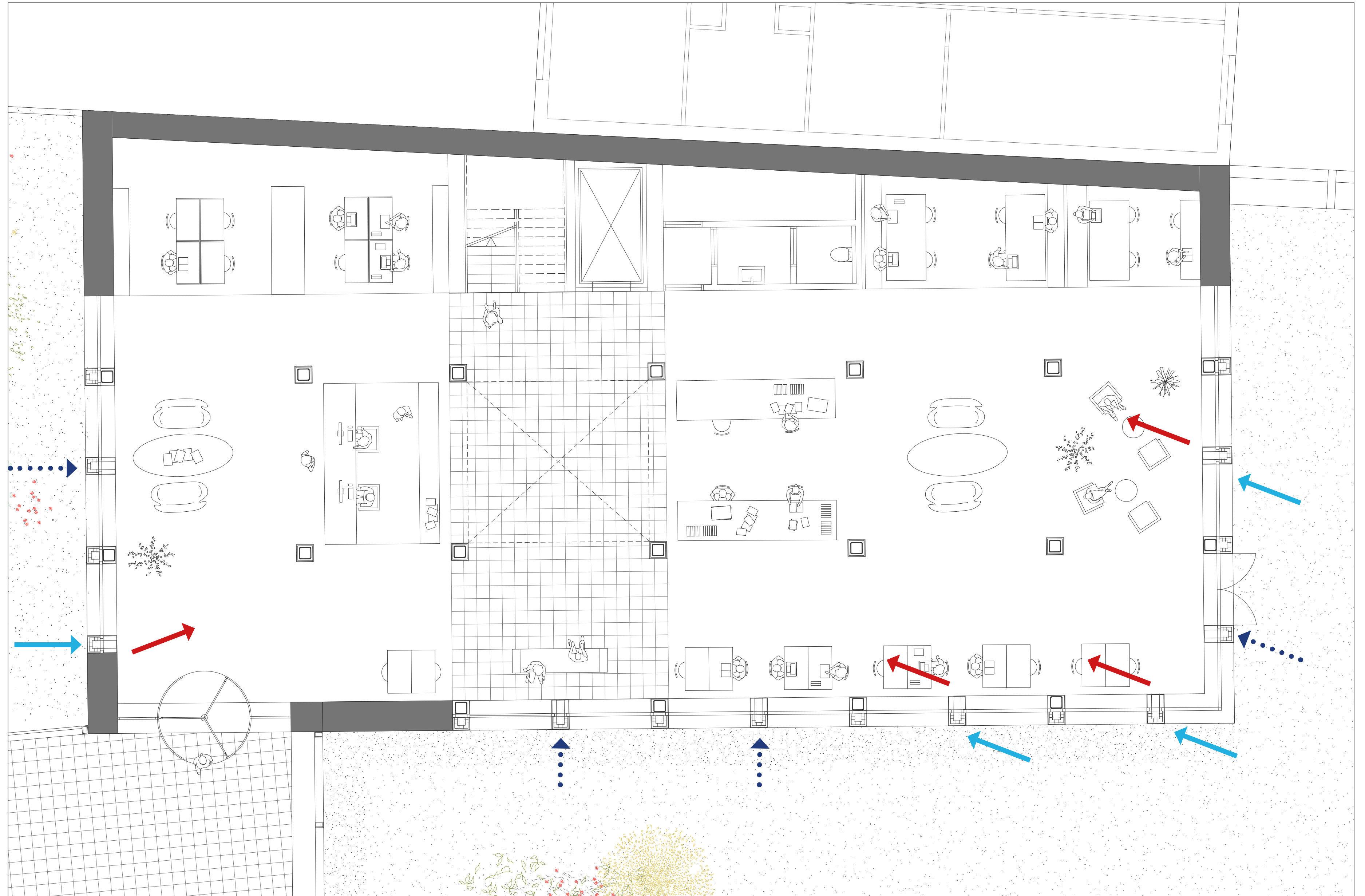
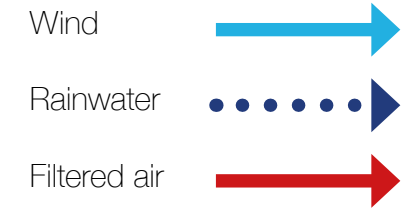

ARCHIVE

1:50
Second floor

Ventilation principle archival spaces

Treated air from WTW



Extraction 'dirty air' ventilation unit



**WTW: RETRIEVING FRESH AIR
FROM ROOF**

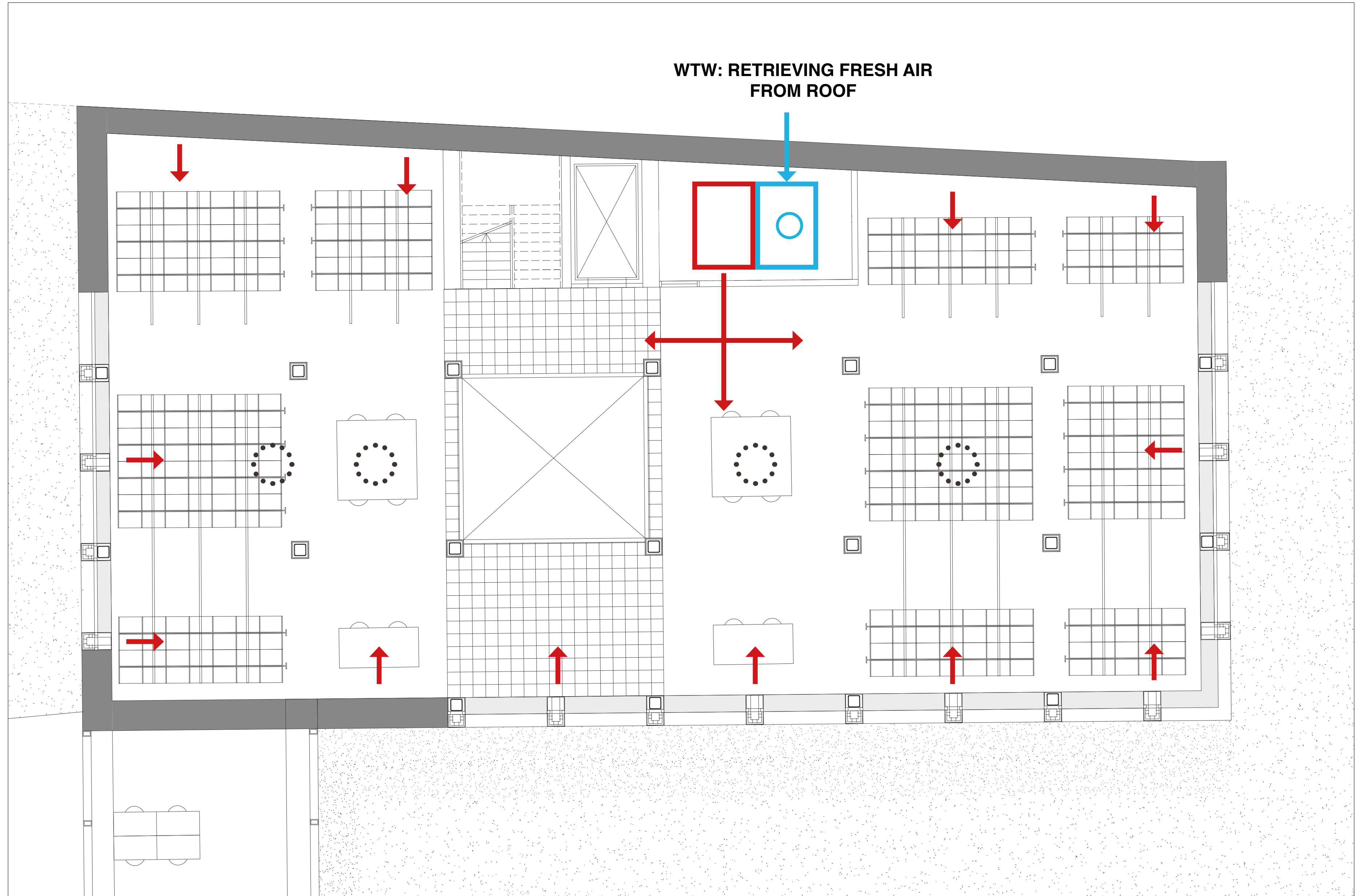

ARCHIVE

1:5

Ventilation principle

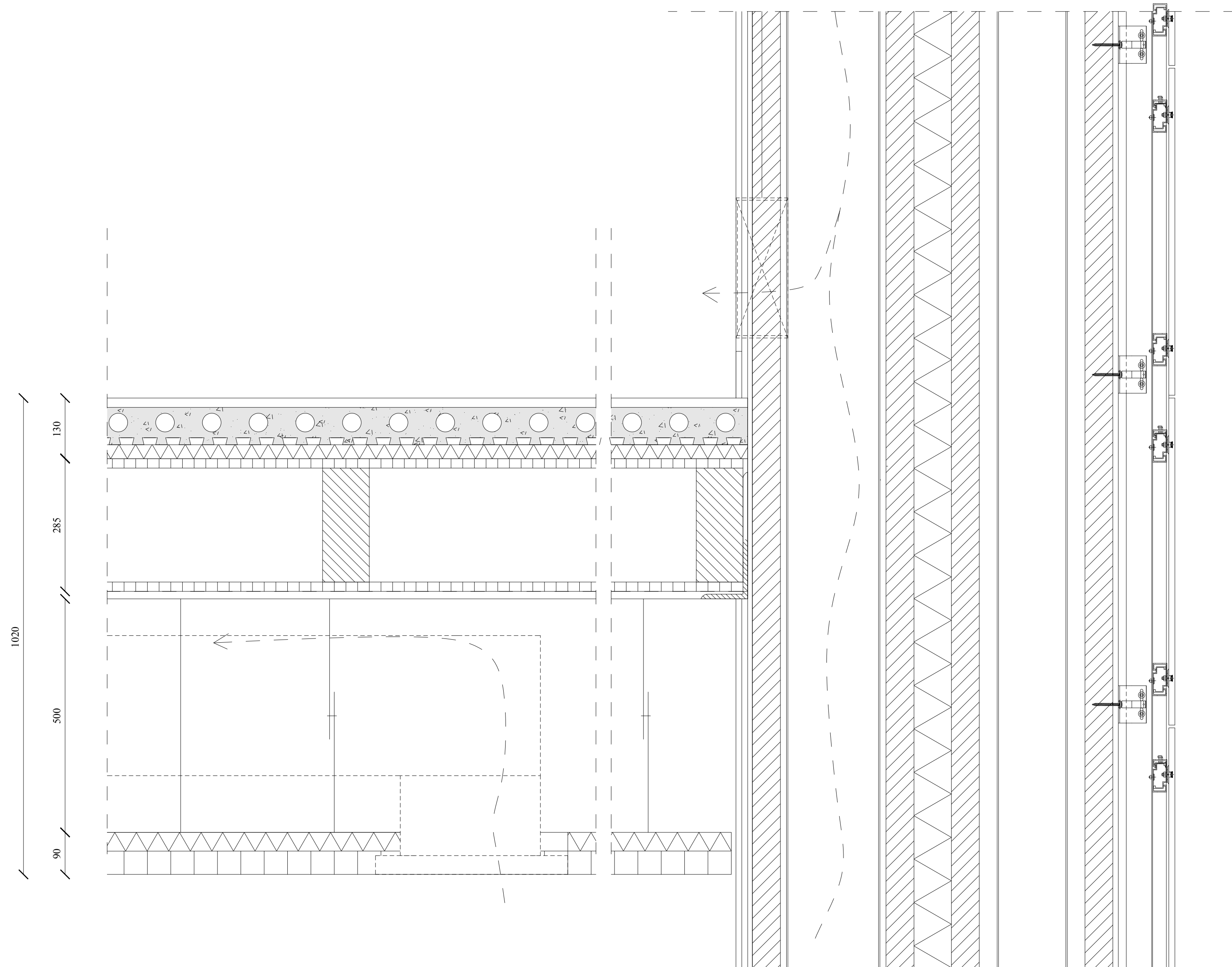

KINDERGARTEN

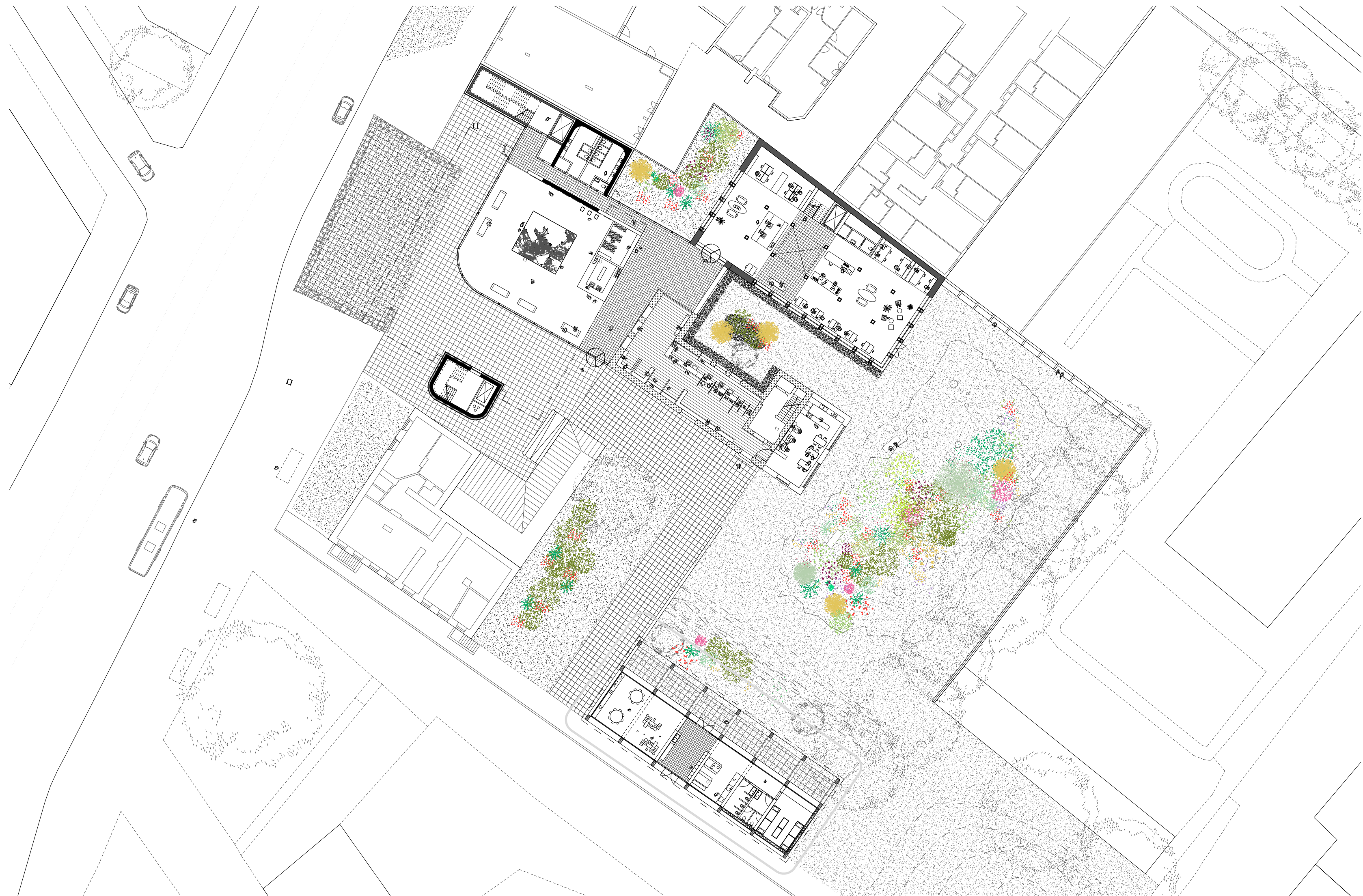

KINDERGARTEN

1:50
Ground floor

- 1 Entrance
- 2 Door to garden
- 3 Children's area
- 4 Kitchen
- 5 Toilets
- 6 Sleeping room
- 7 Garden

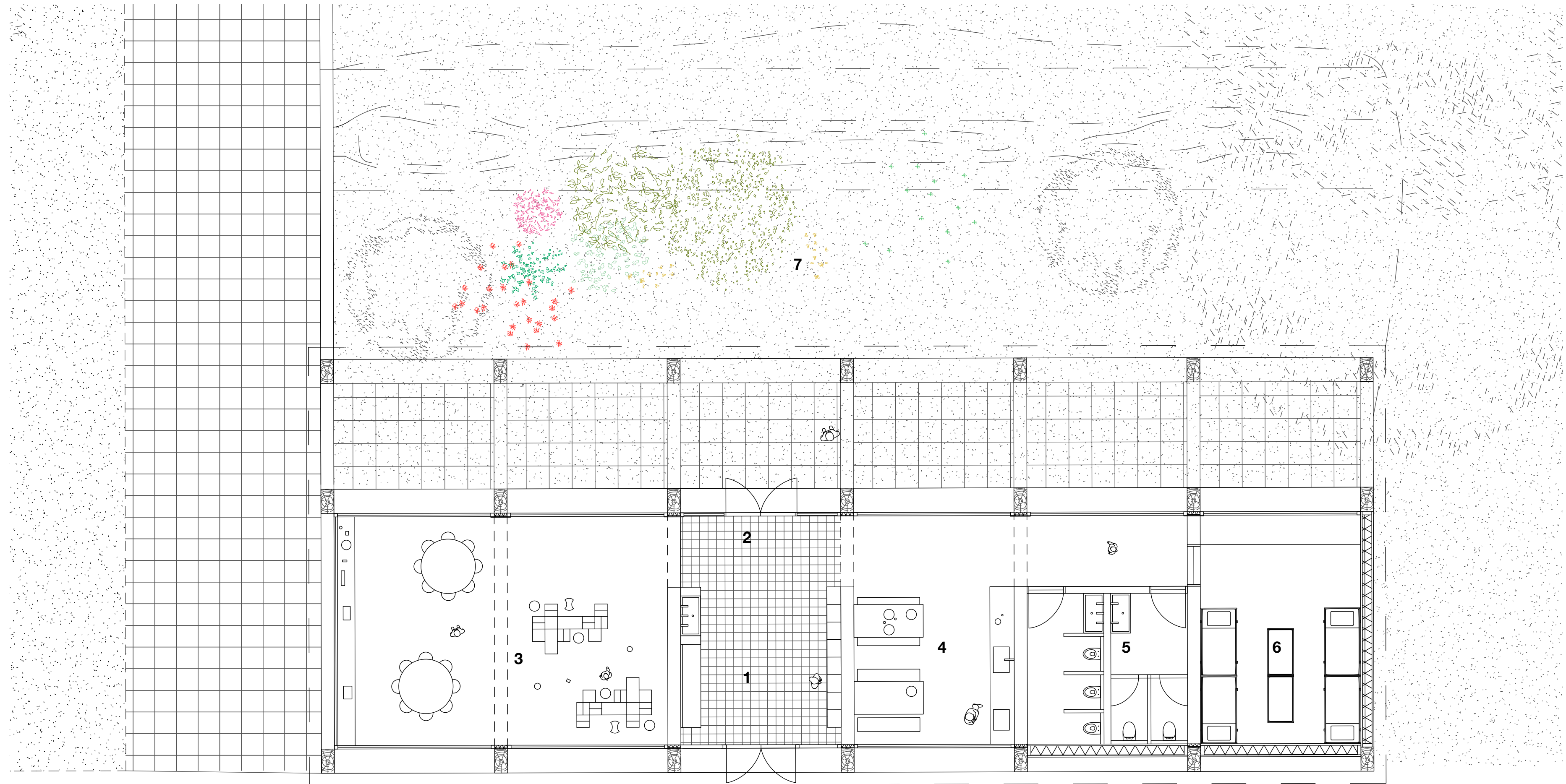

KINDERGARTEN



KINDERGARTEN

1:50
Elevation



KINDERGARTEN

1:50
Section

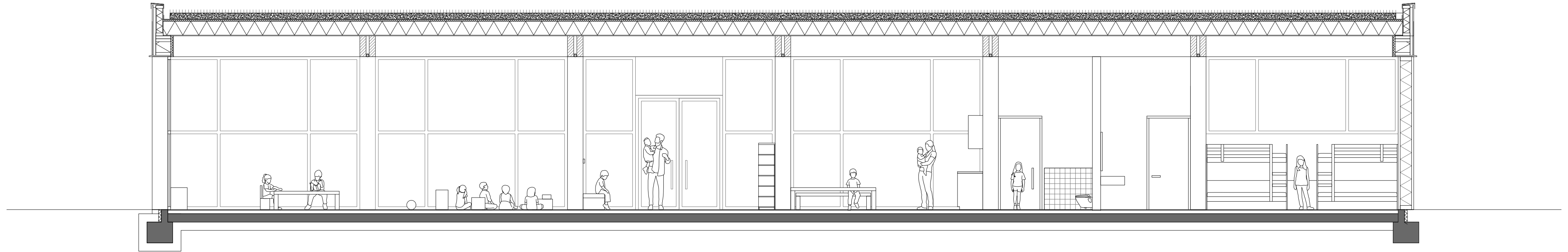

KINDERGARTEN

1:20
Section

Top-bottom

Extensive greening
150 mm substrate
40 mm drainage layer
Sealant layer
Insulation
Fiber panel
Secondary wooden beam structure

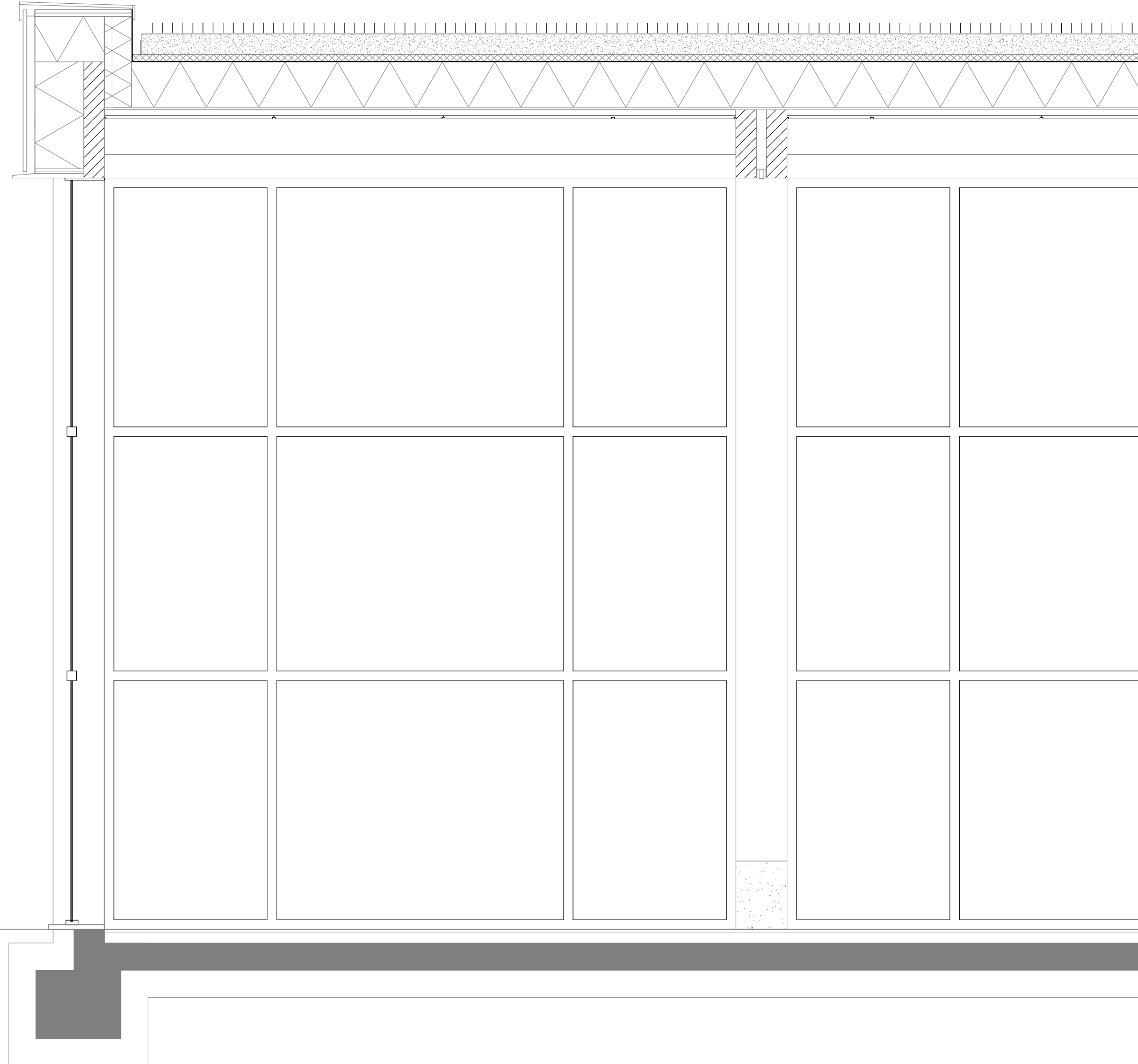



GARDEN

1:50
Ground Floor

- 1 Ruinous garden
- 2 Bench
- 3 Seating integrated in a wall

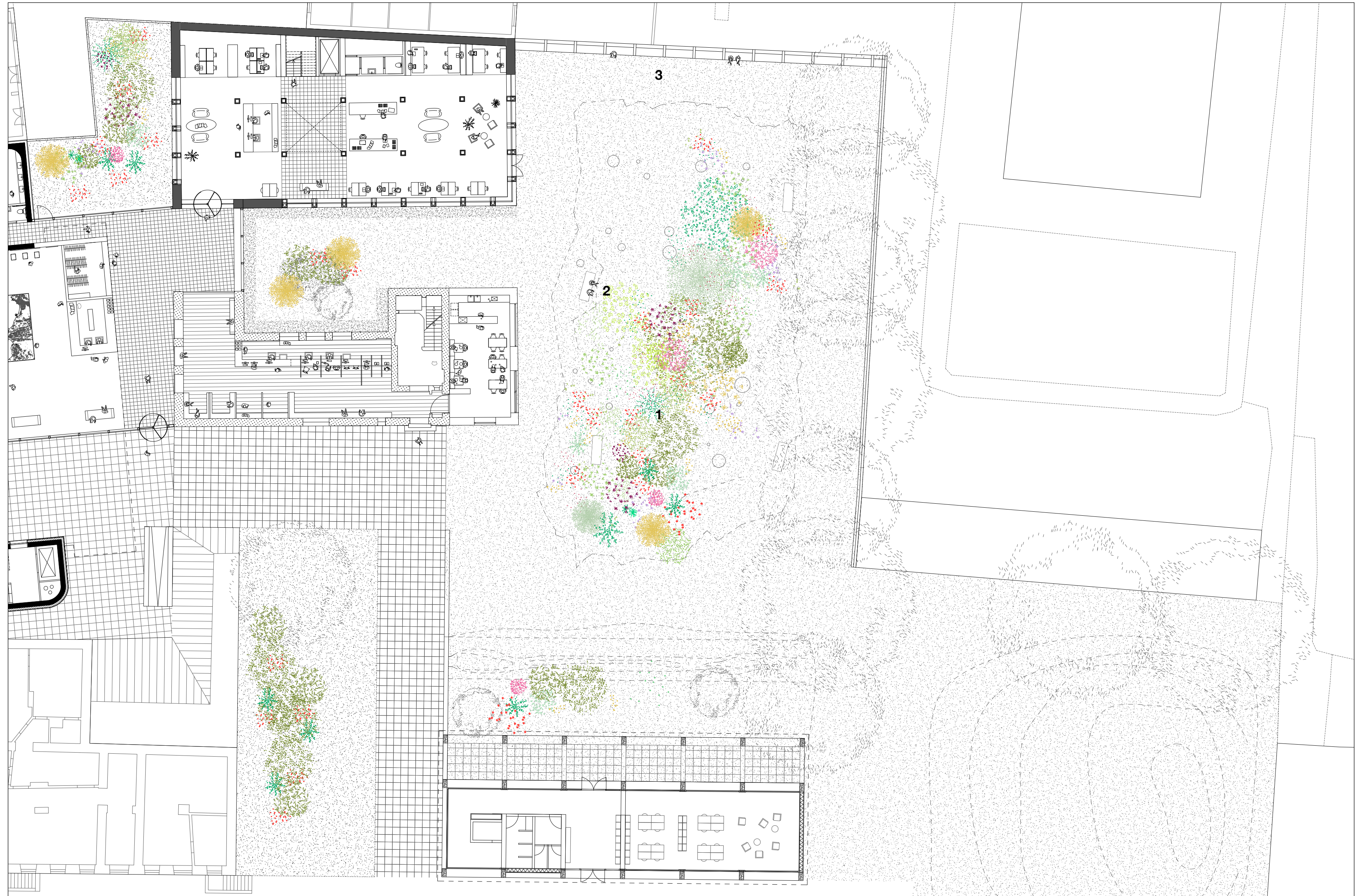

SECTION

1:200

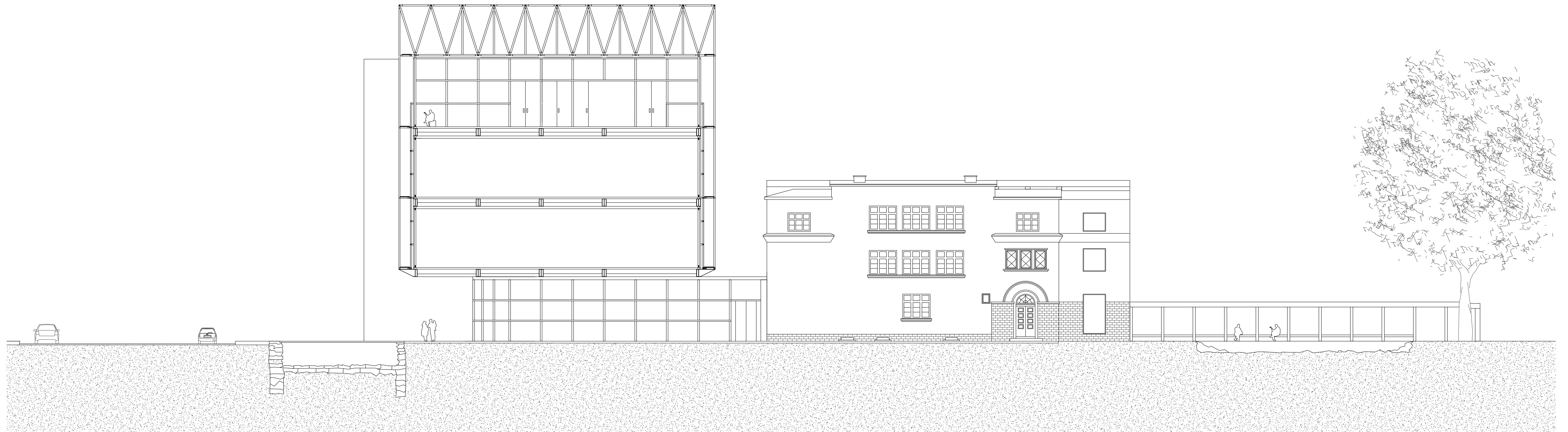





1953



2023



proposal

REFLECTION

THE FORUM FOR THE BUILT ENVIRONMENT IS A NEW ADDITION TO THE CITY OF TALLINN WHILE OFFERING A RECOGNISABLE PROGRAMMATIC IDENTITY.

REFLECTION

THE FORUM FOR THE BUILT ENVIRONMENT IS A NEW ADDITION TO THE CITY OF TALLINN WHILE OFFERING A RECOGNISABLE PROGRAMMATIC IDENTITY. THE PROJECT ACTIVATES DISCUSSION THROUGH OFFERING IT SPACIALLY, BUT ALSO IN ITS PROGRAM. THE ARCHIVE BEHOLDS THE MEMORY OF THE CITY, AND POSITIONING IT IN THE FORUM GIVES IT THE OPPORTUNITY TO RETHINK ABOUT THE PAST AND THE FUTURE. THE OTHER PROGRAMS SUPPORT THE FOUNDATIONS FOR DISCUSSION.

THANK YOU!

AND SPECIAL THANKS TO

JORGE MEJÍA HERNÁNDEZ
FREEK SPEKSNIJDER
WILLIE VOGEL

DAAN KOK
ELENA PRADO
HARRY VAN DER LAAN
ANTON VAN DER LAAN

SANETTE SCHEURS
RENS HOOFS
ALMIRA TANRIKULU
TIM VAN HAREN
ISABEL OFFENBERG
PELLE RADEMAKERS
STEFAN SINNIGE
JULIA VAN DER PLOEG

YIYING DAI
XIANG YUN
LENORE LIU
BALINT KEREKES
HADASSAH FIDDER
LUISA ZEILINGER
KATHLEEN PANARITI