

Experiencing Social Transition

High Streets and Community Kitchens as thresholds of social progress

Name Mats Ruppert

Student number 4589548

Studio Name / Theme AR3DC100 / Architectural Design Crossovers /

Heterogeneous City: London

Fascination



London Lines





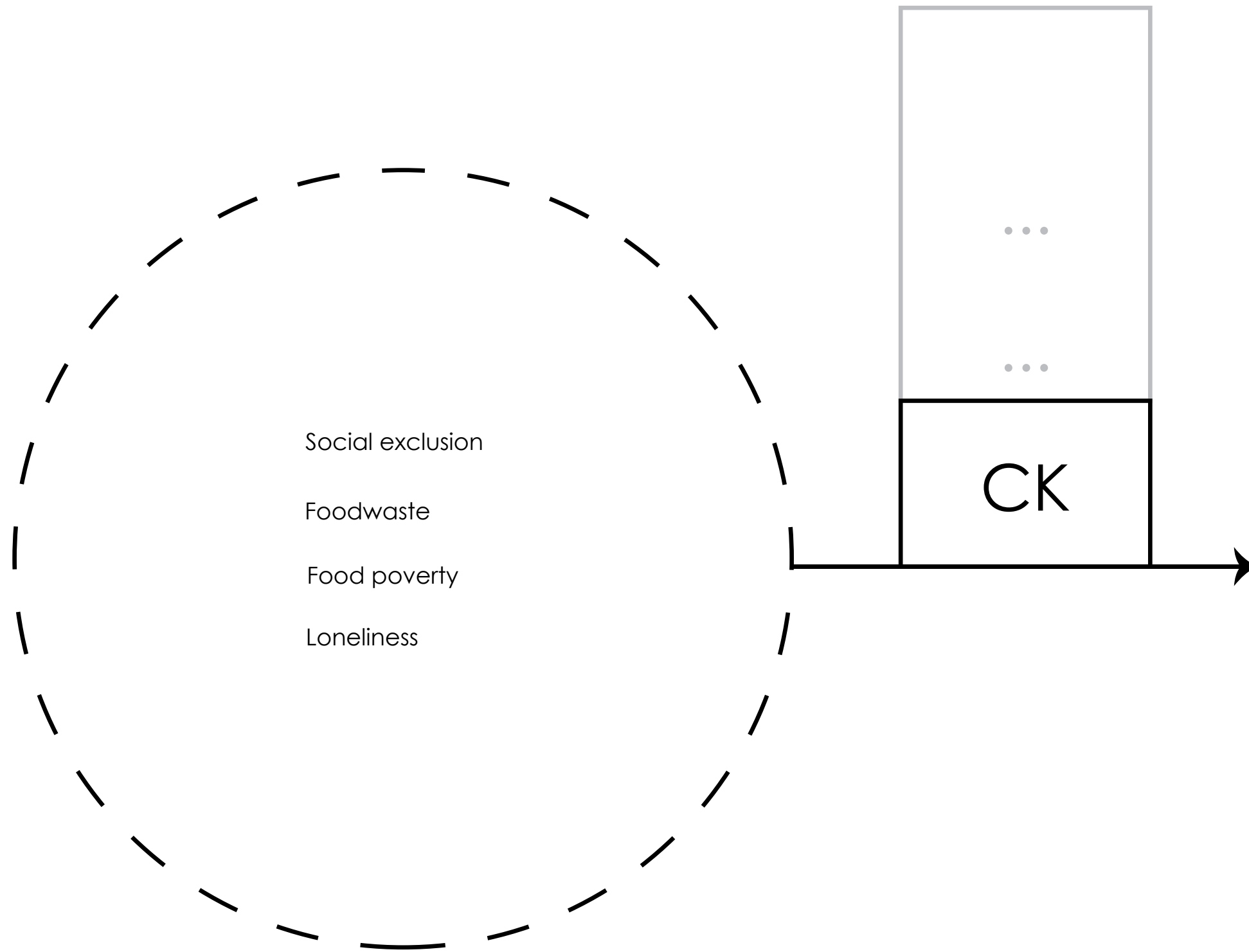

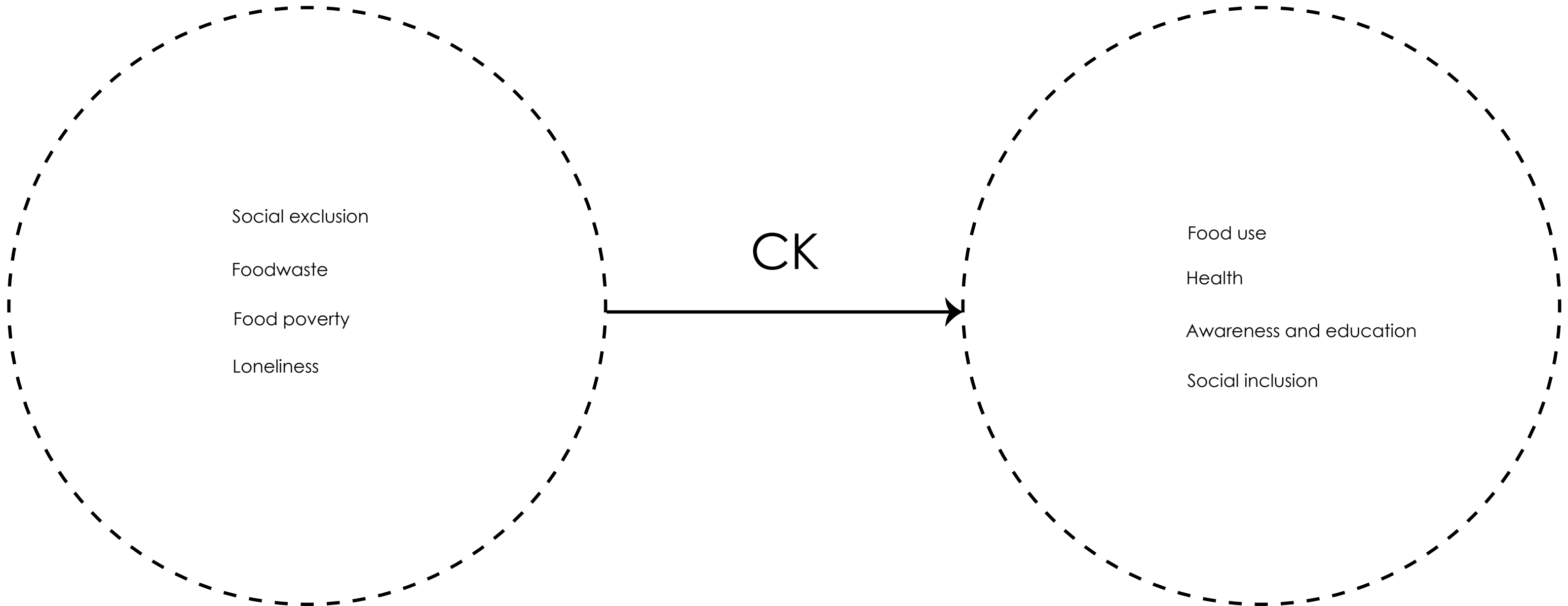

“Visiting the food bank is a shameful experience for food bank users, because the visit at the food bank makes them aware that they are partly socially excluded.”

HS

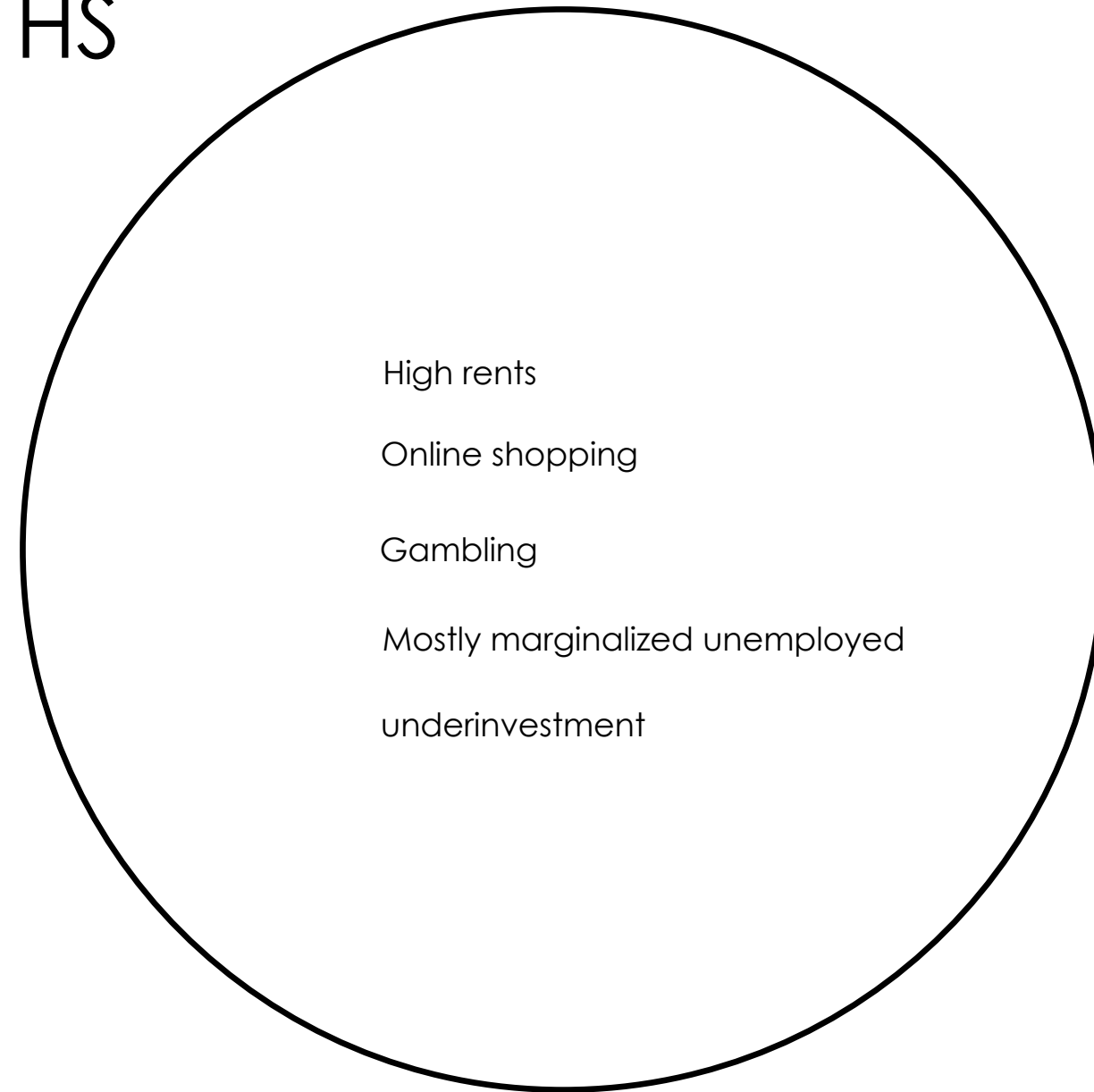

HS

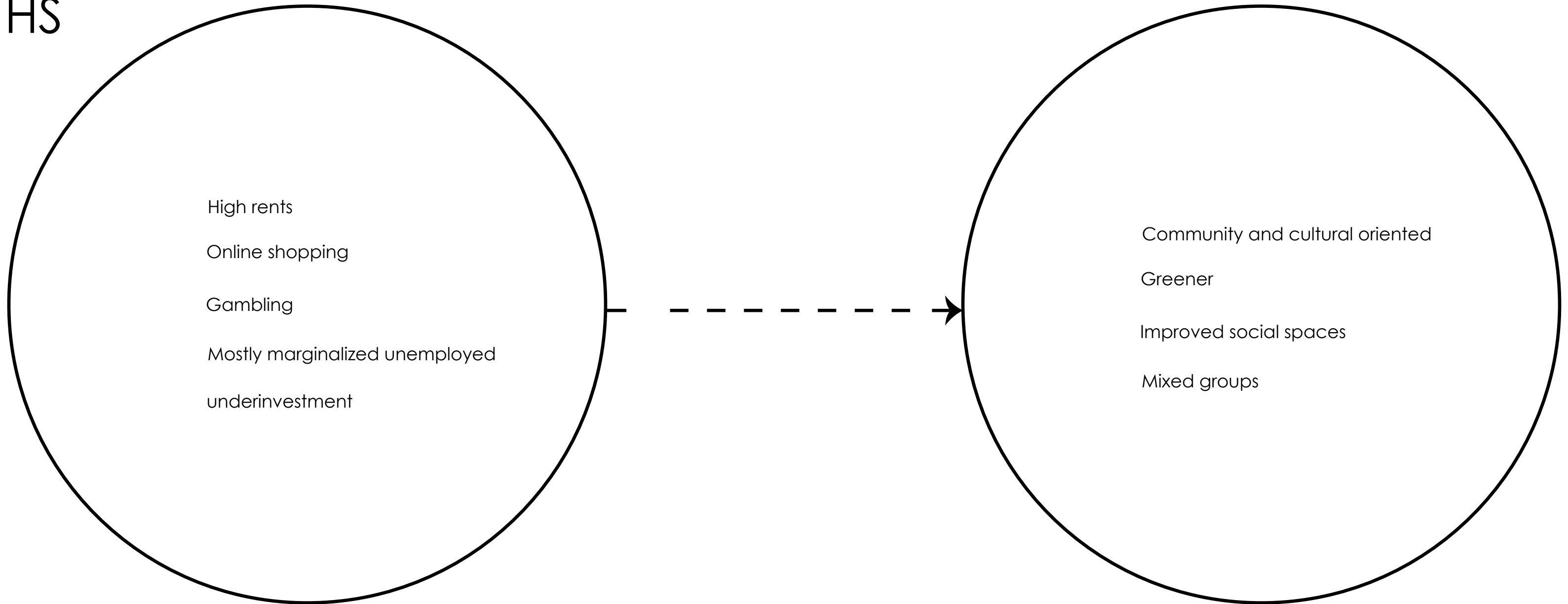

How can a ethnically diverse and commercial high street contribute to a transition towards the social inclusion of community kitchens?

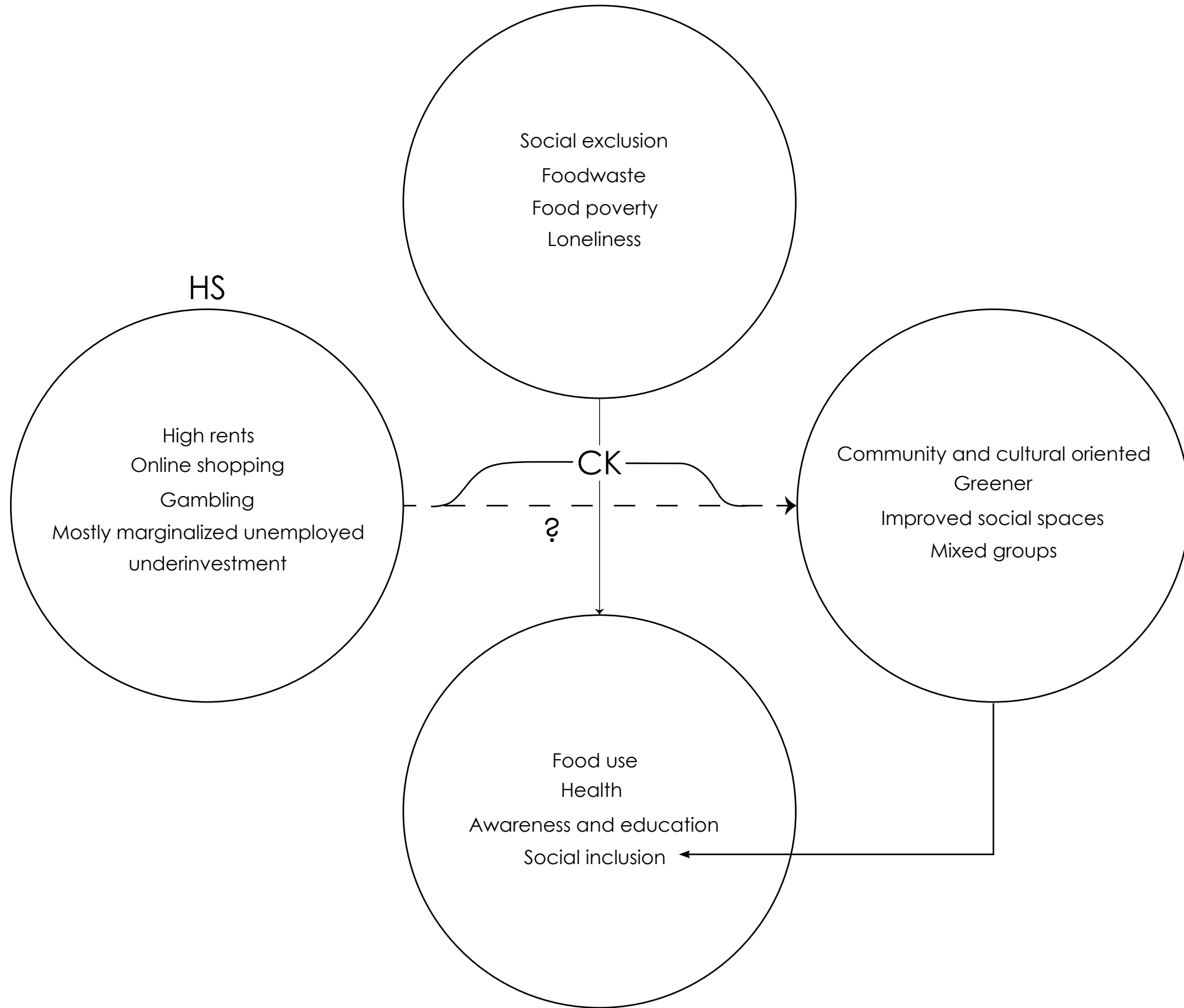



Social Experience

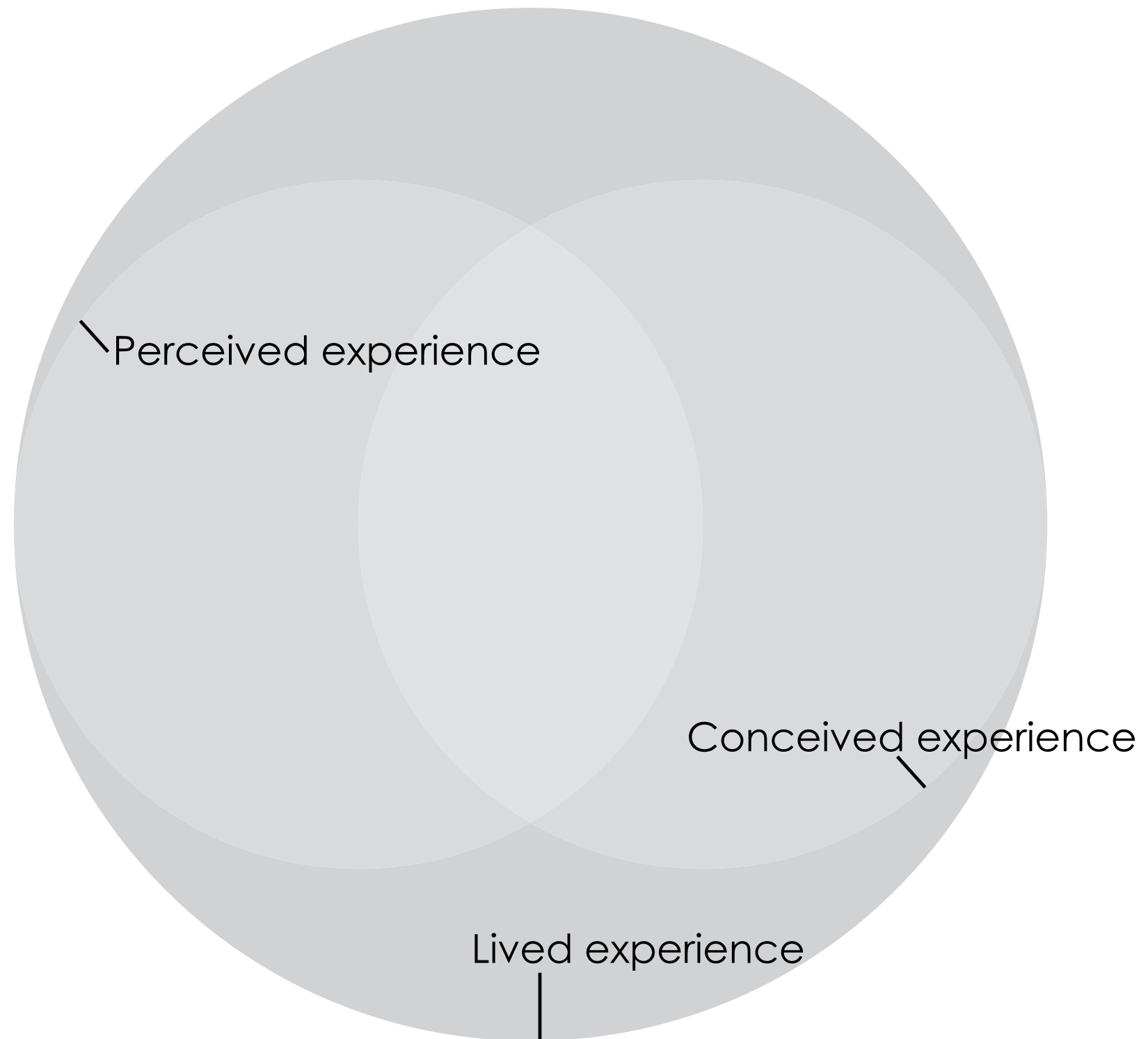

The Proces or Moment of Lived Experience

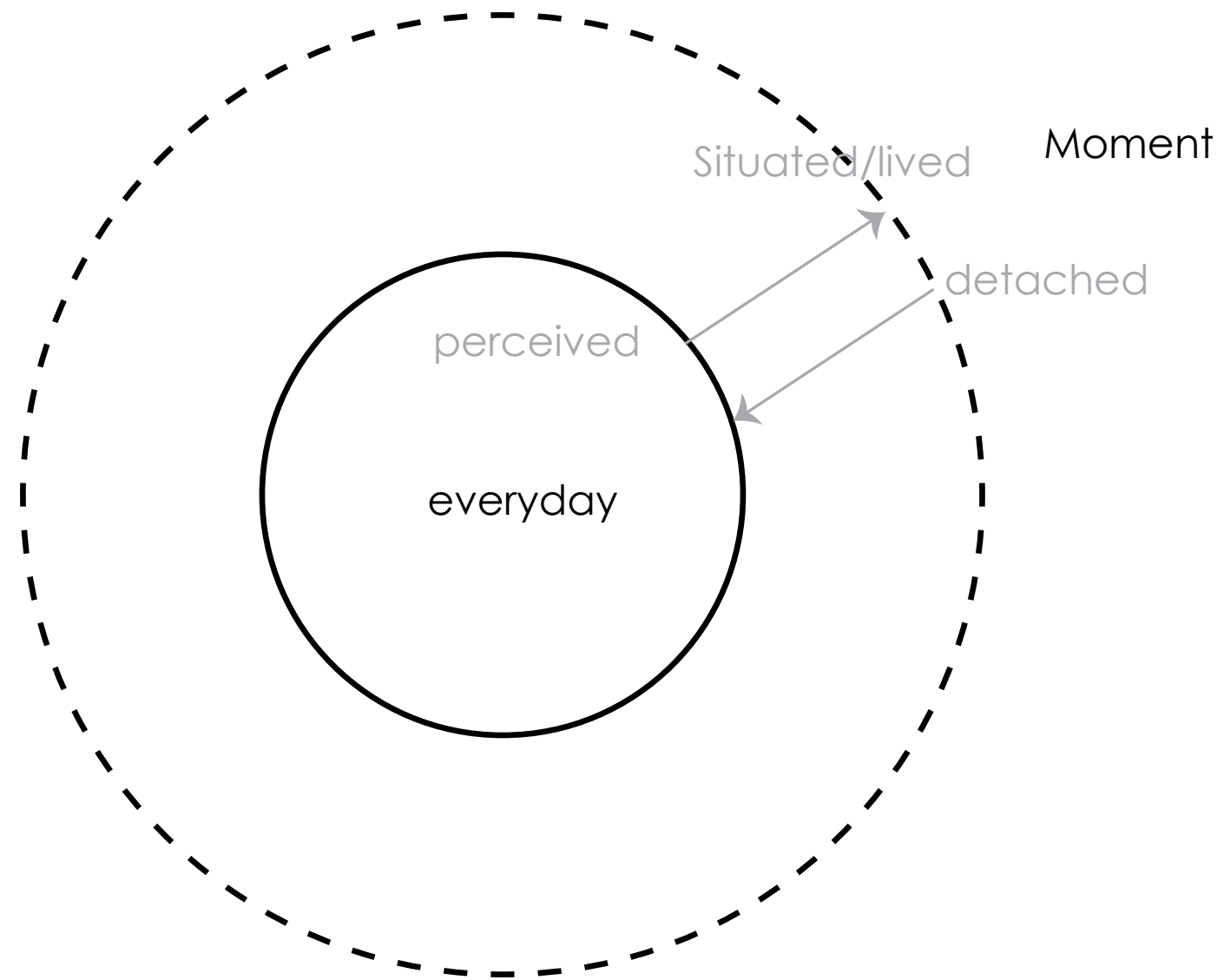

the moment is the lived experience of a individual triggered by a possibility and taken by choice

possibility

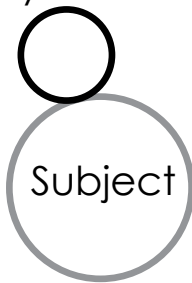

possibility perceived

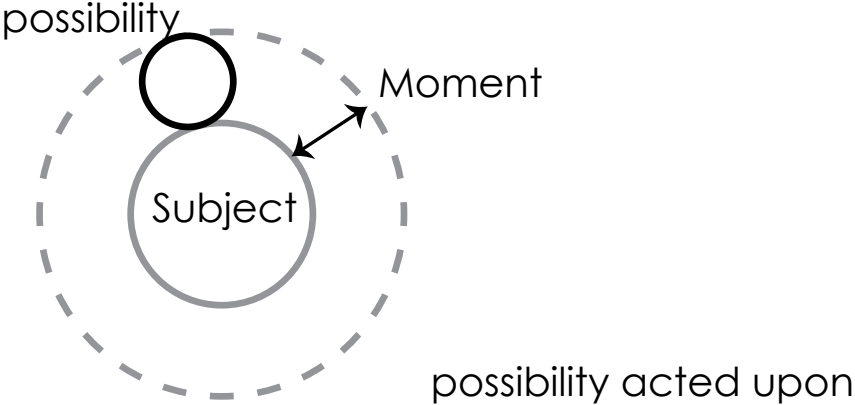

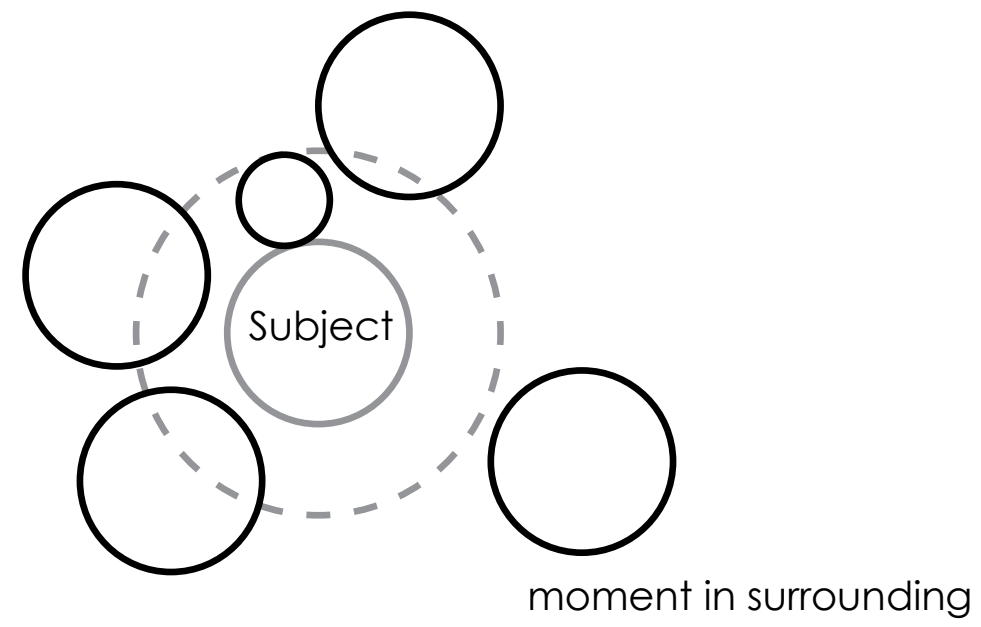

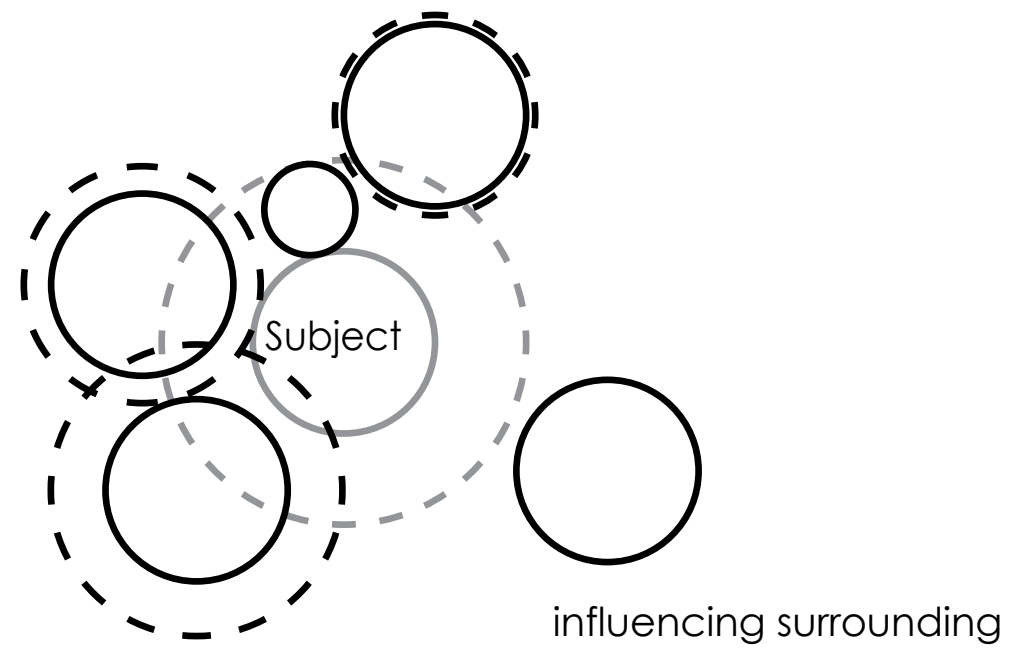

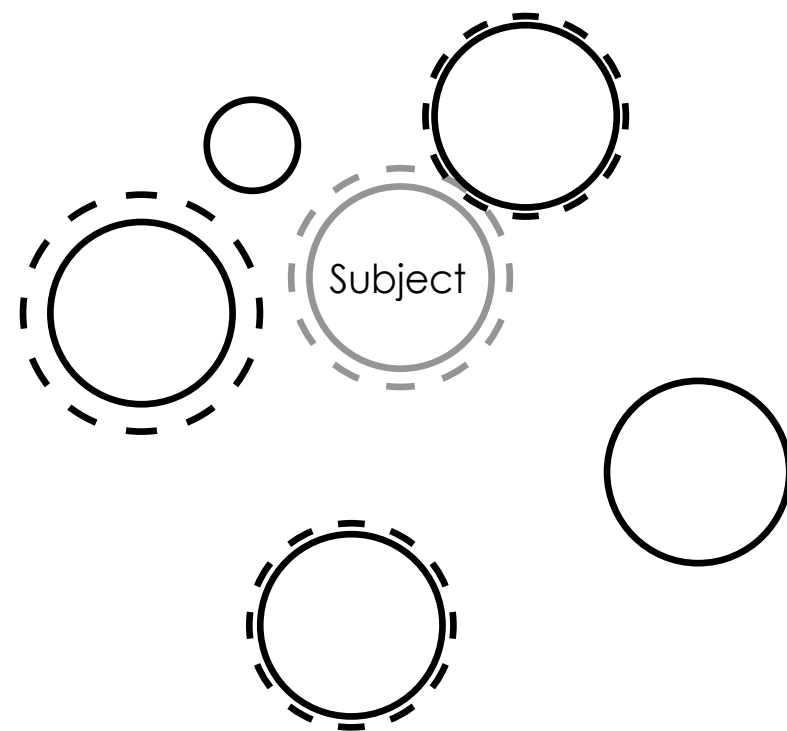

surrounding reorganized

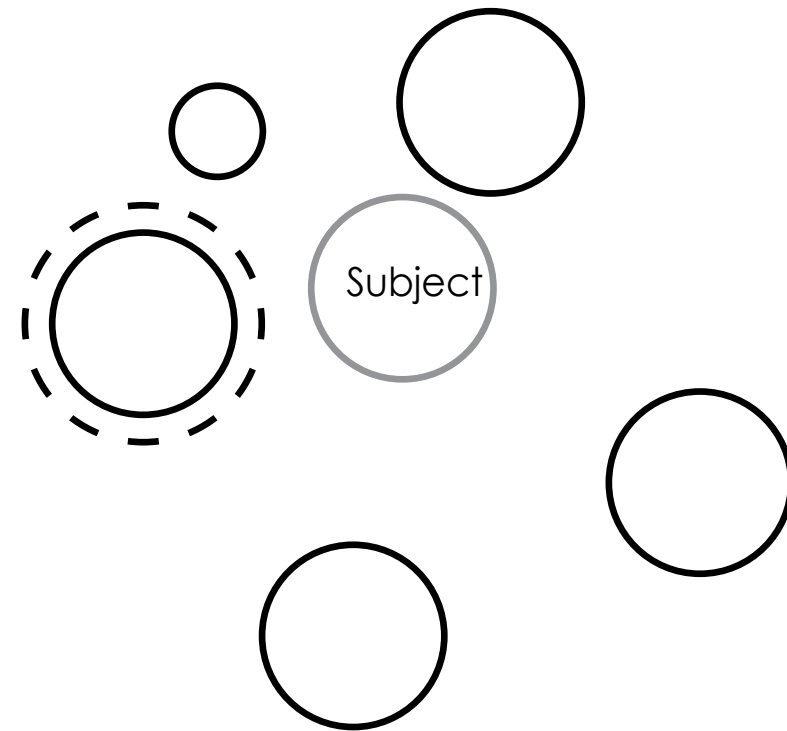

Moment over, but maybe
lives on in another

How?

Conviviality

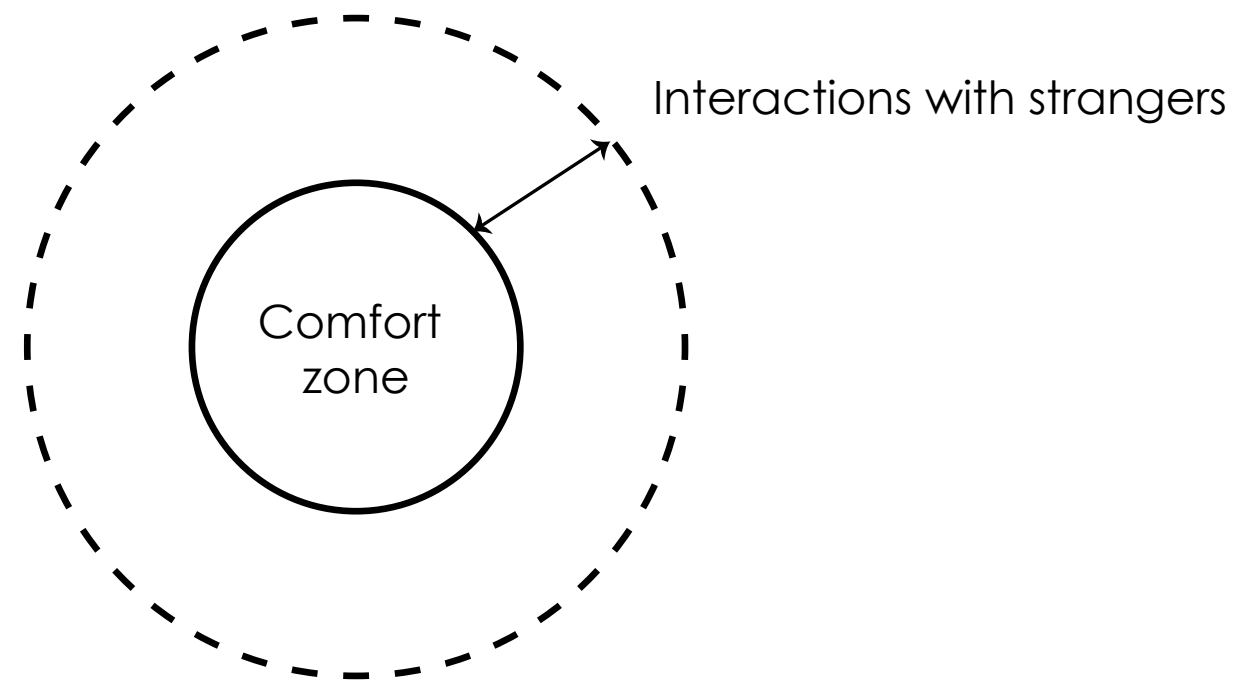

affectively at ease relations of coexistence

Play

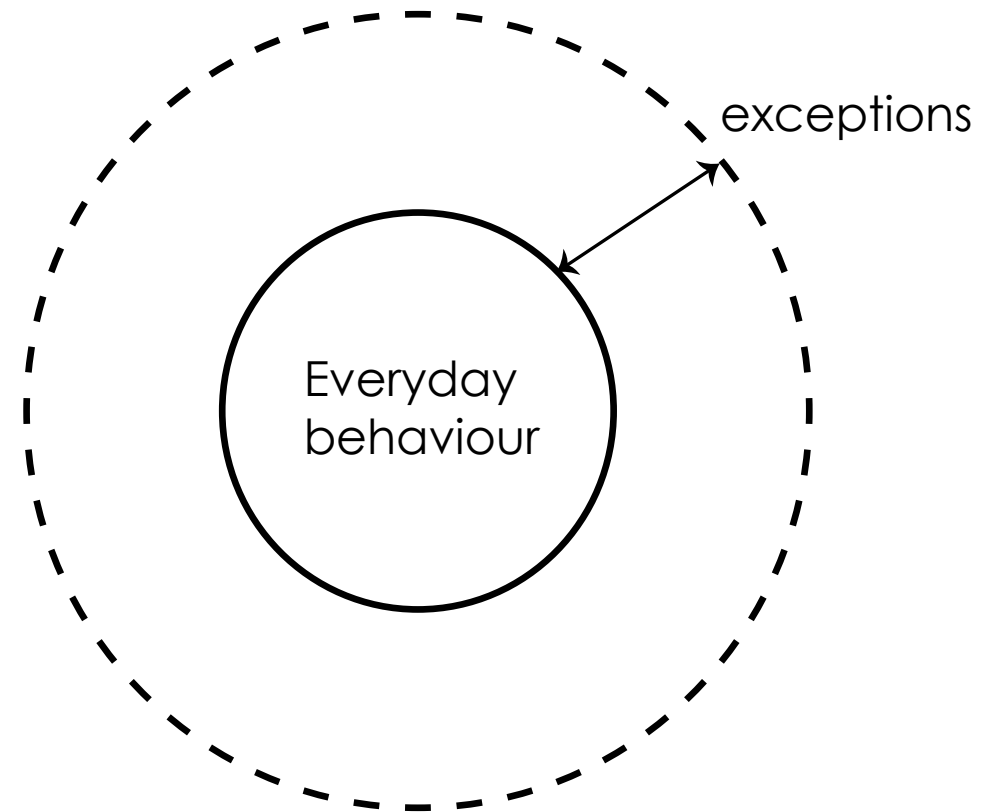

a contrast to our normal, everyday behavior

Where?

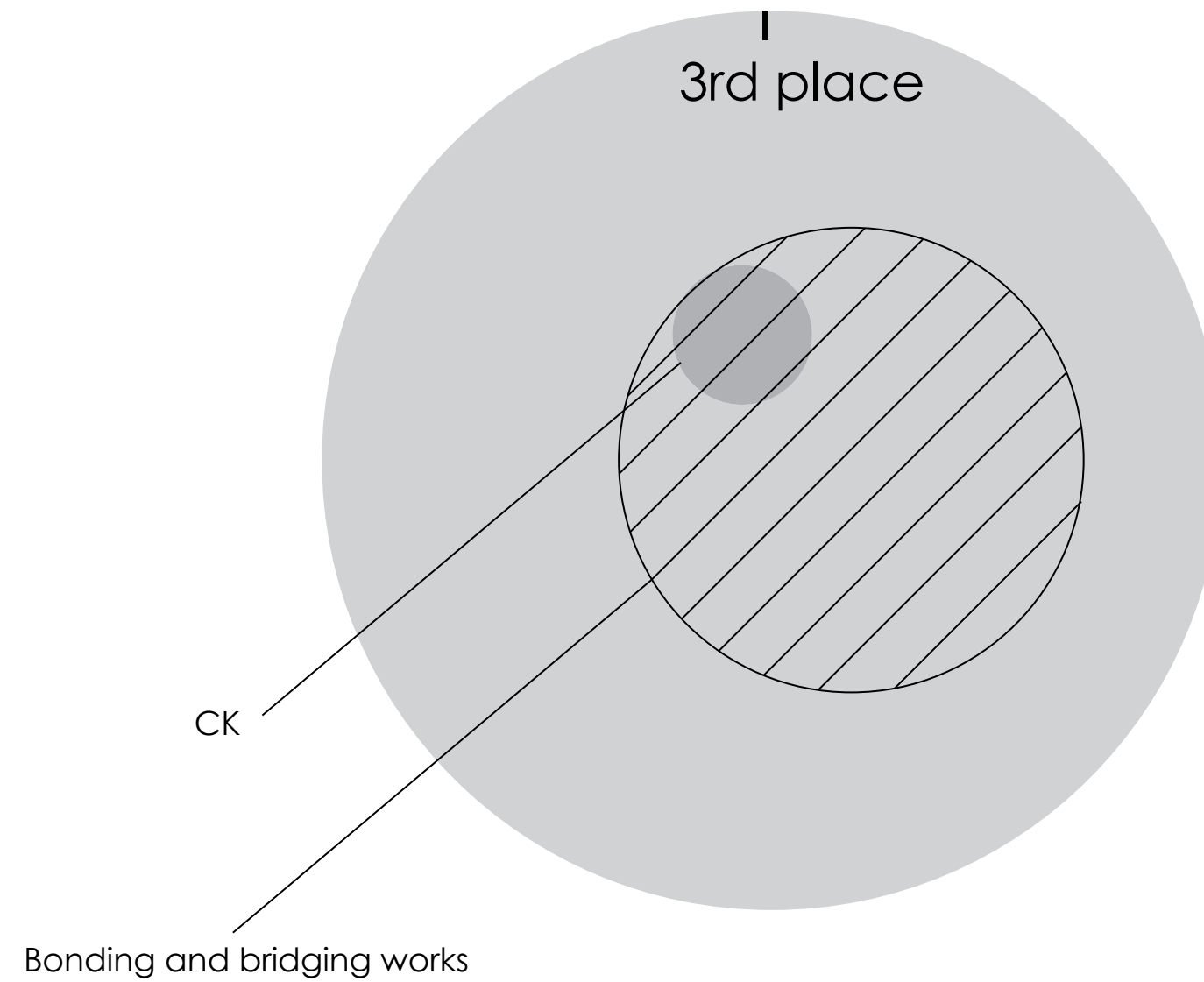

Third places are in succession to the first place (home) and second place (work), the destination locations where people come together



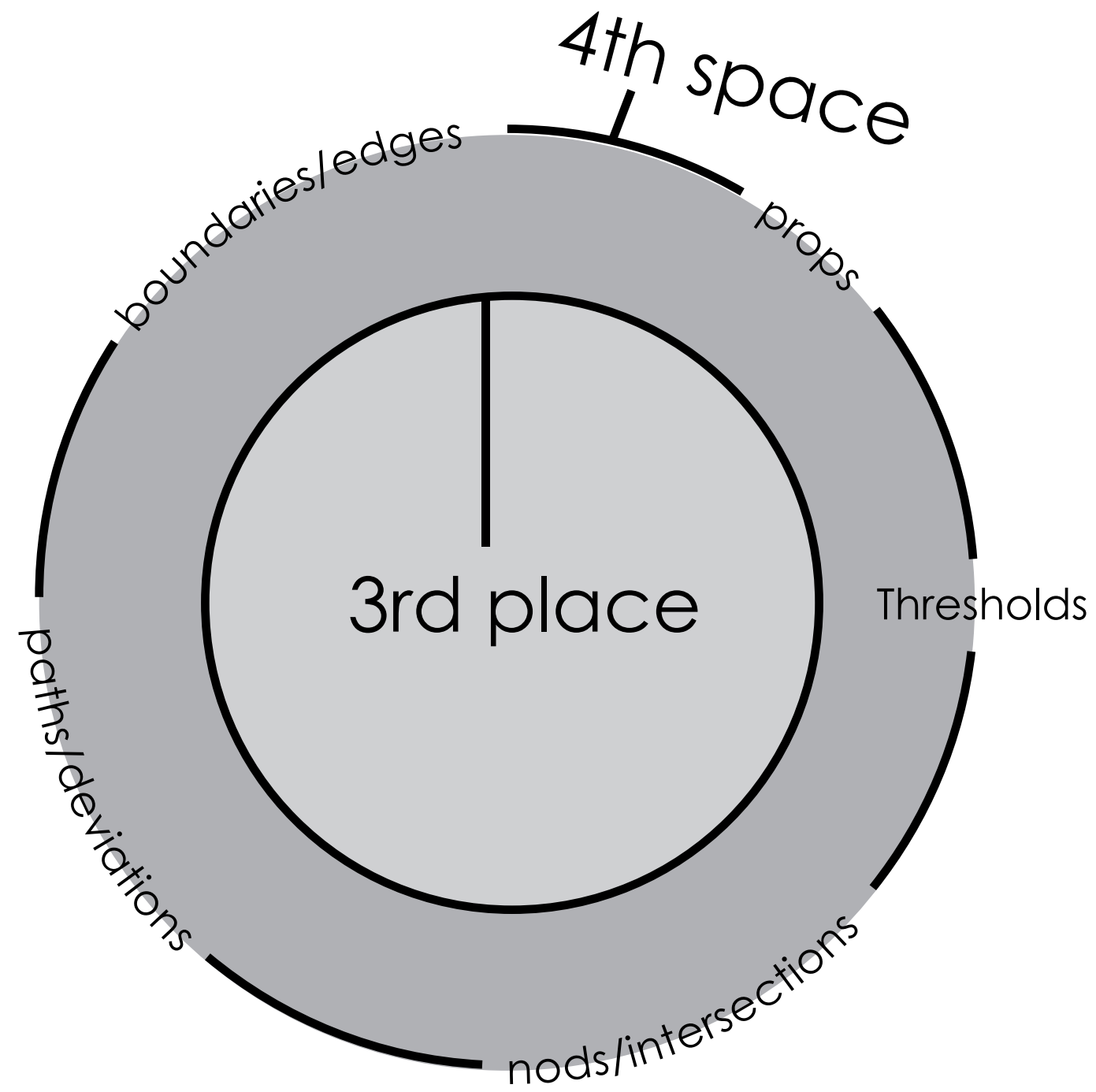

informal social settings closely related to and around "third places"



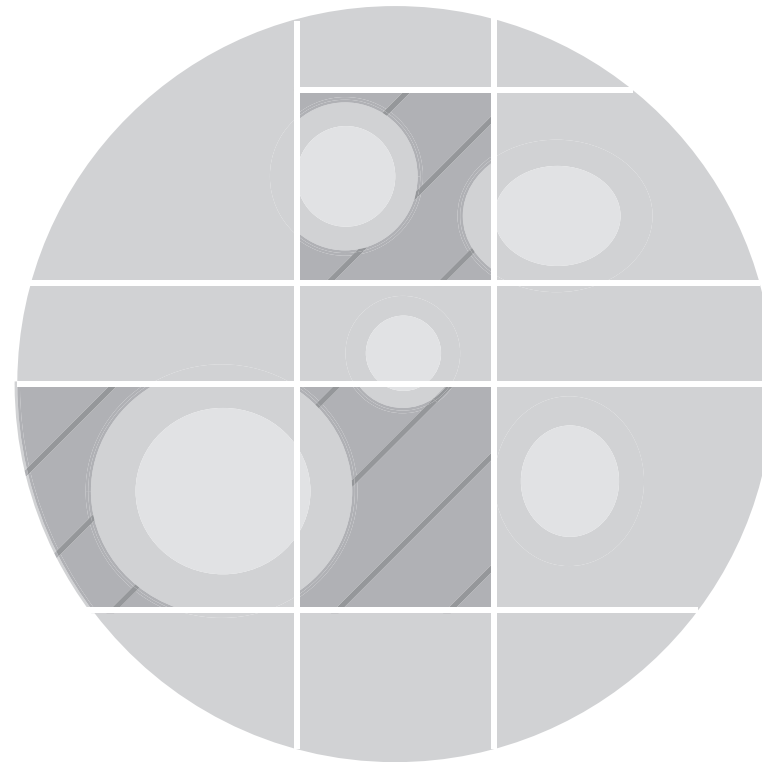

Loose space



characterized by citizen appropriation, where individuals engage in activities that are not predetermined by a set program

Transitional Space

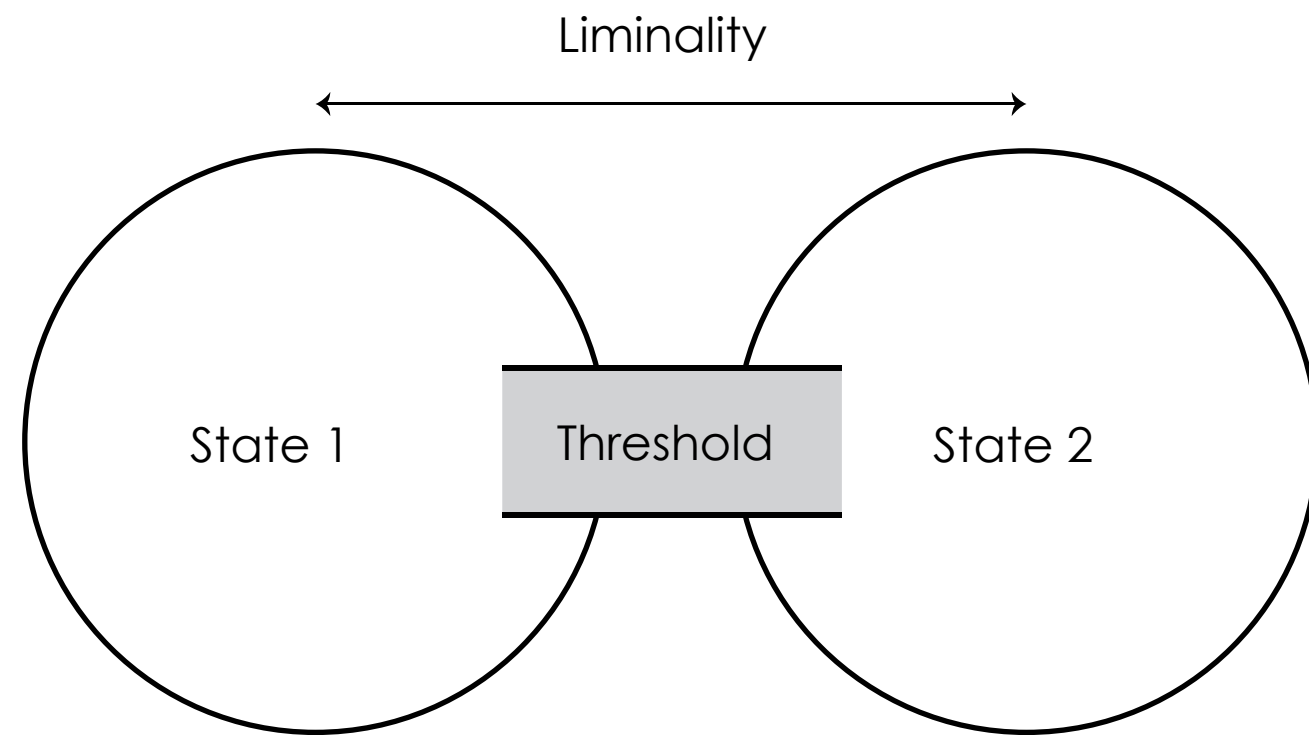

private, public semi scheme

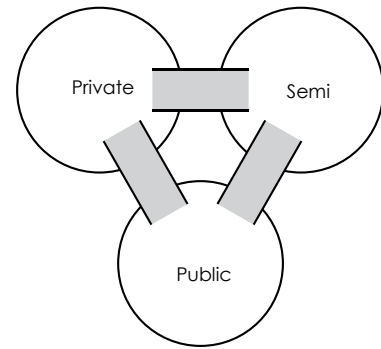

visual connection

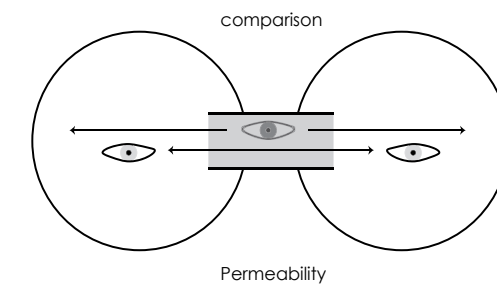

different scales

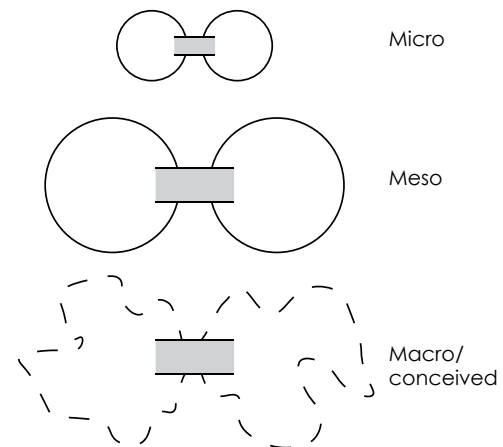

movement, crossing

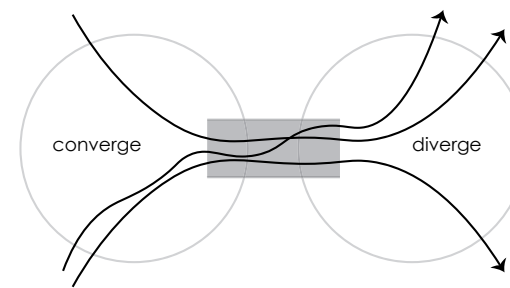

overlap, layering, blurring

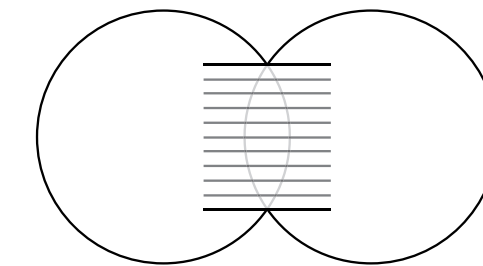

dont overlook, it is a space on its own

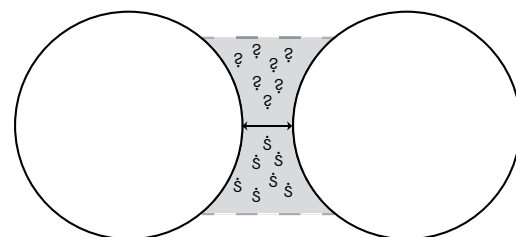

dissolving of the old and appearing of the new

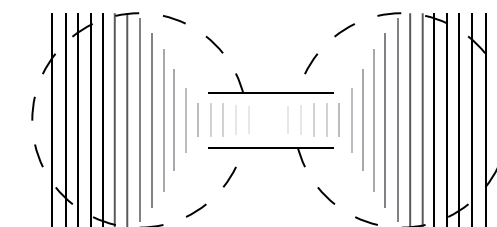

Détournement

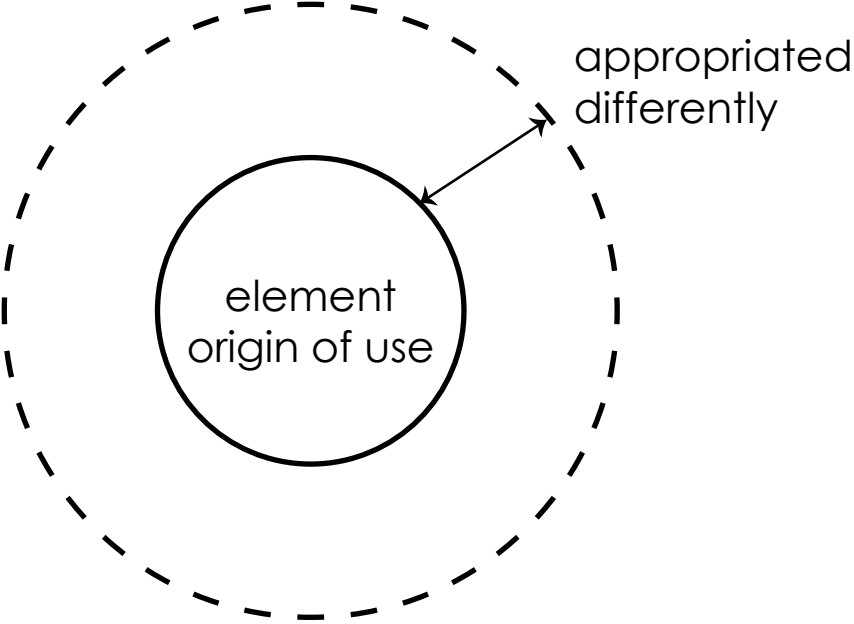

Thresholds of everyday moments

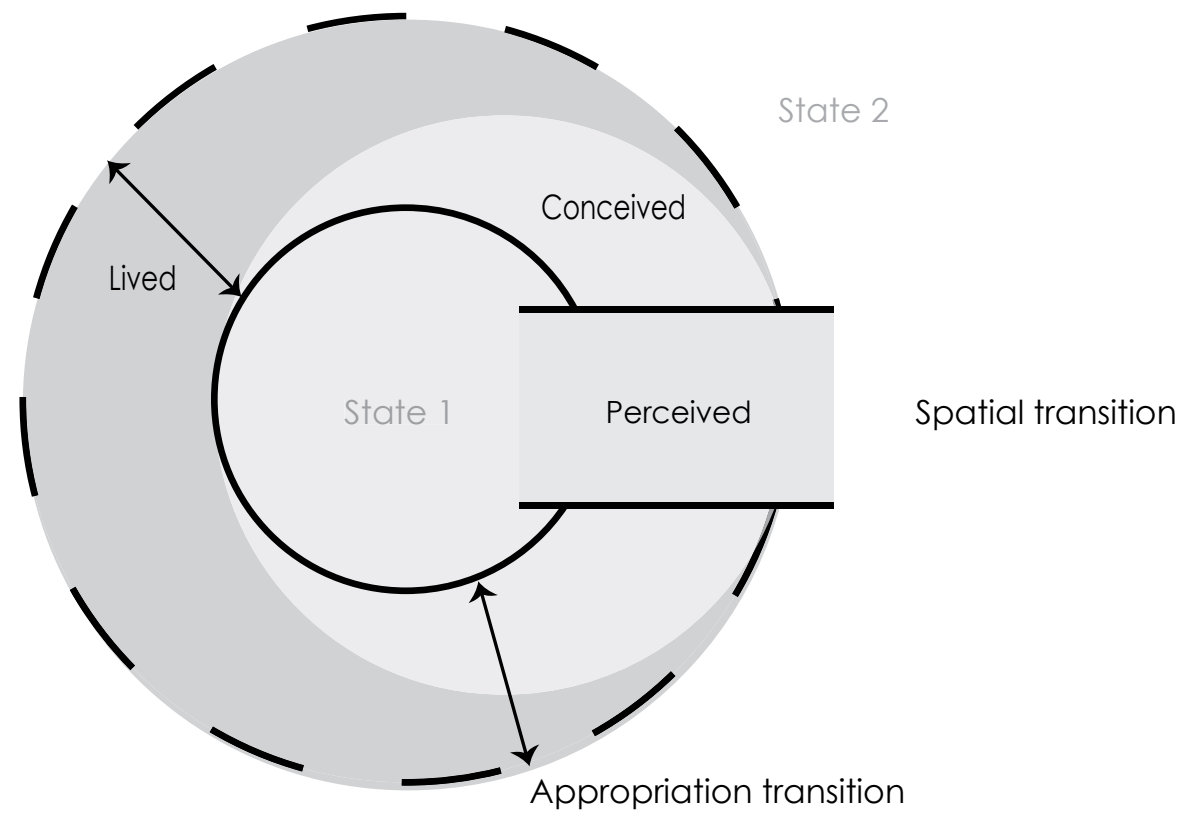

Theory in the context

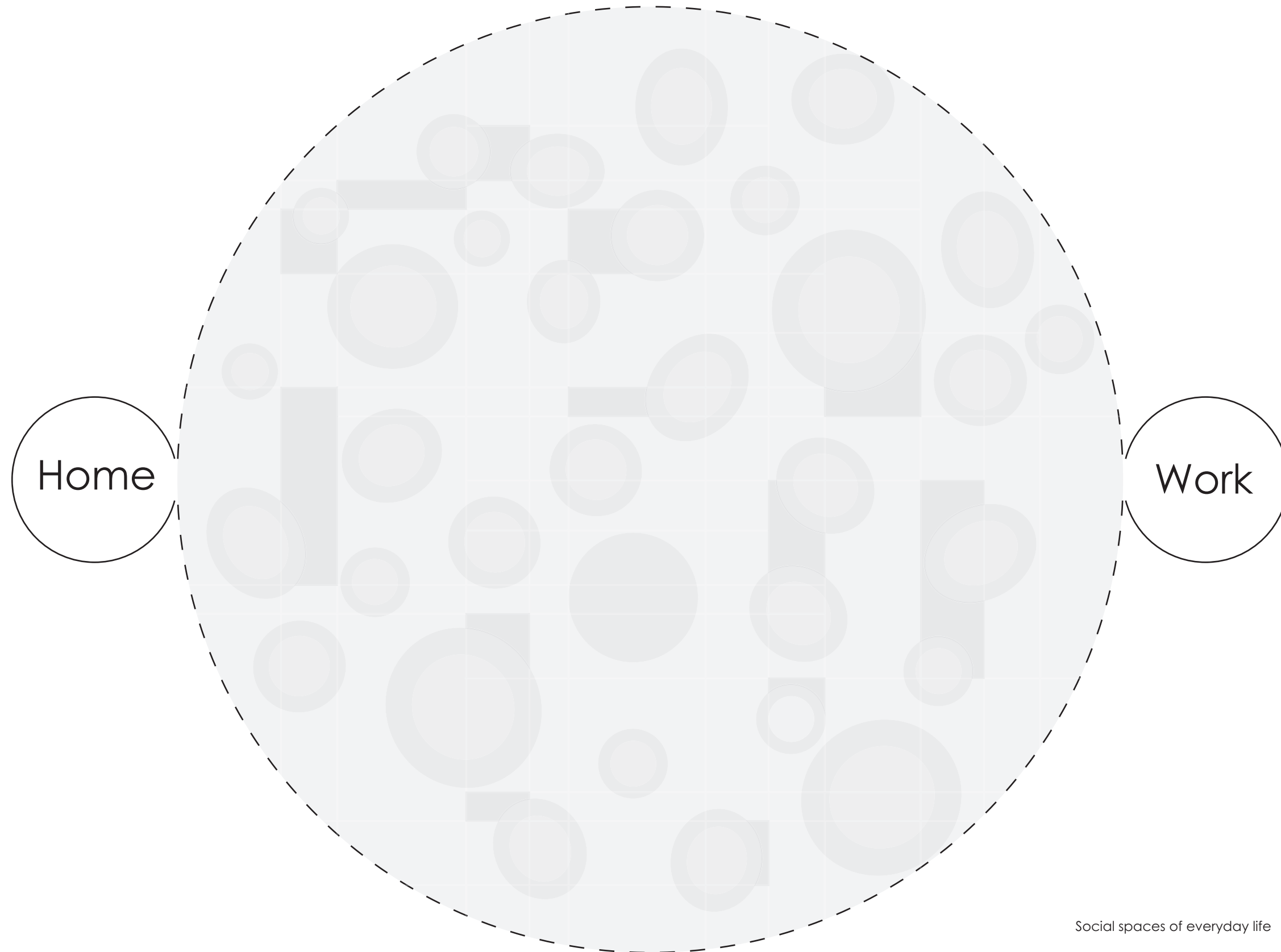

Social spaces of everyday life

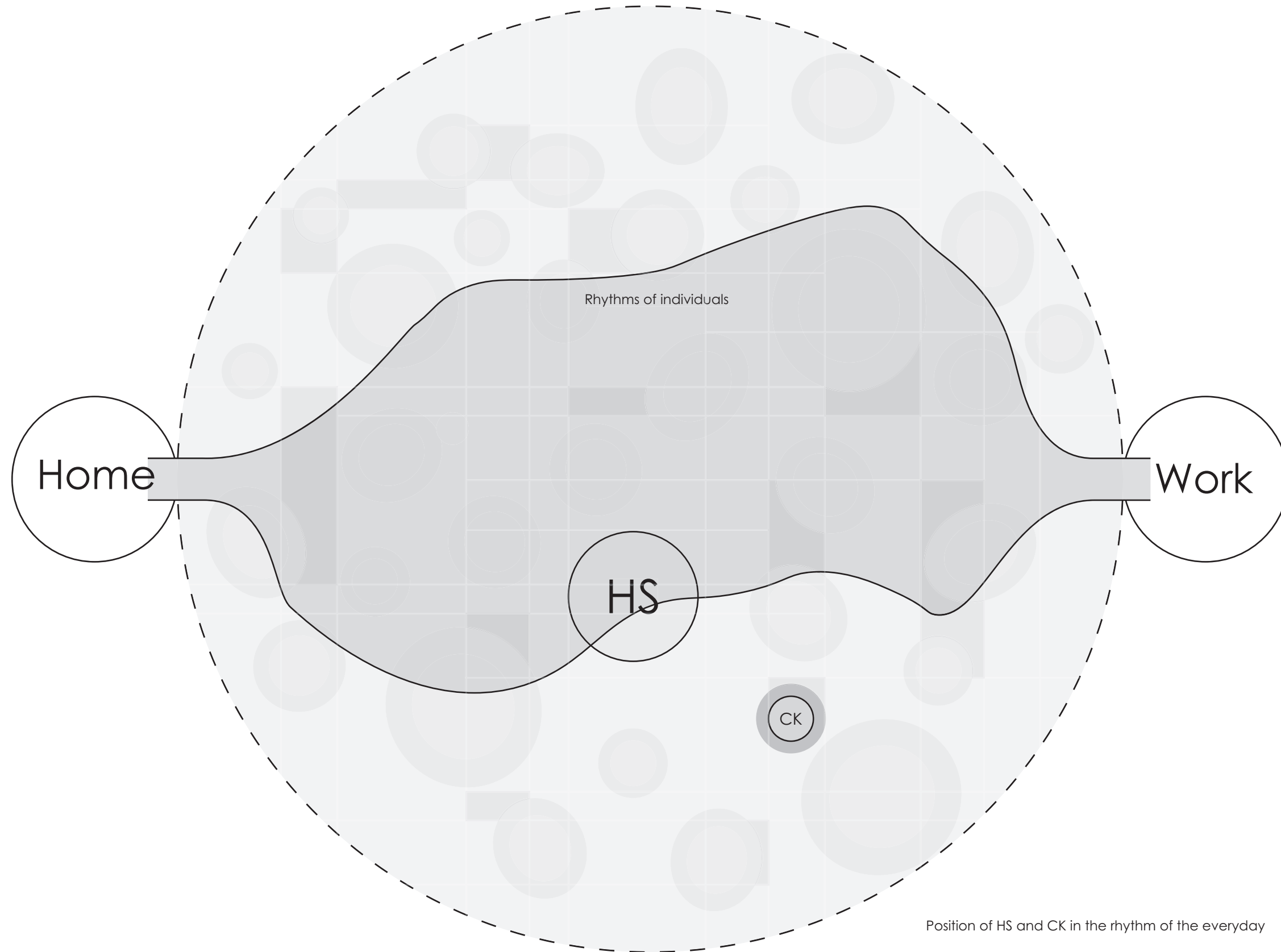

Rhythms of individuals

Home

Work

HS

CK

Position of HS and CK in the rhythm of the everyday

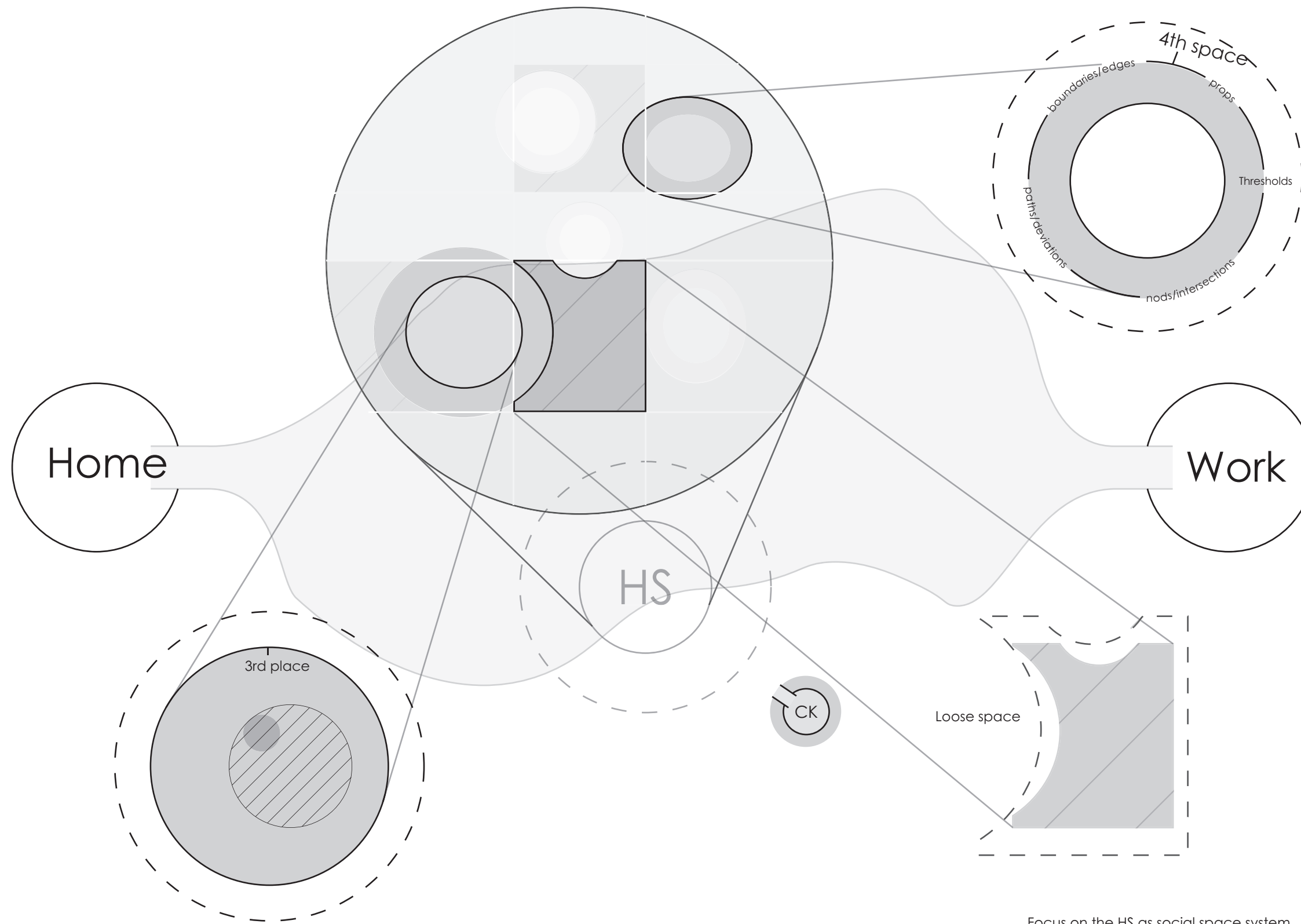

Focus on the HS as social space system

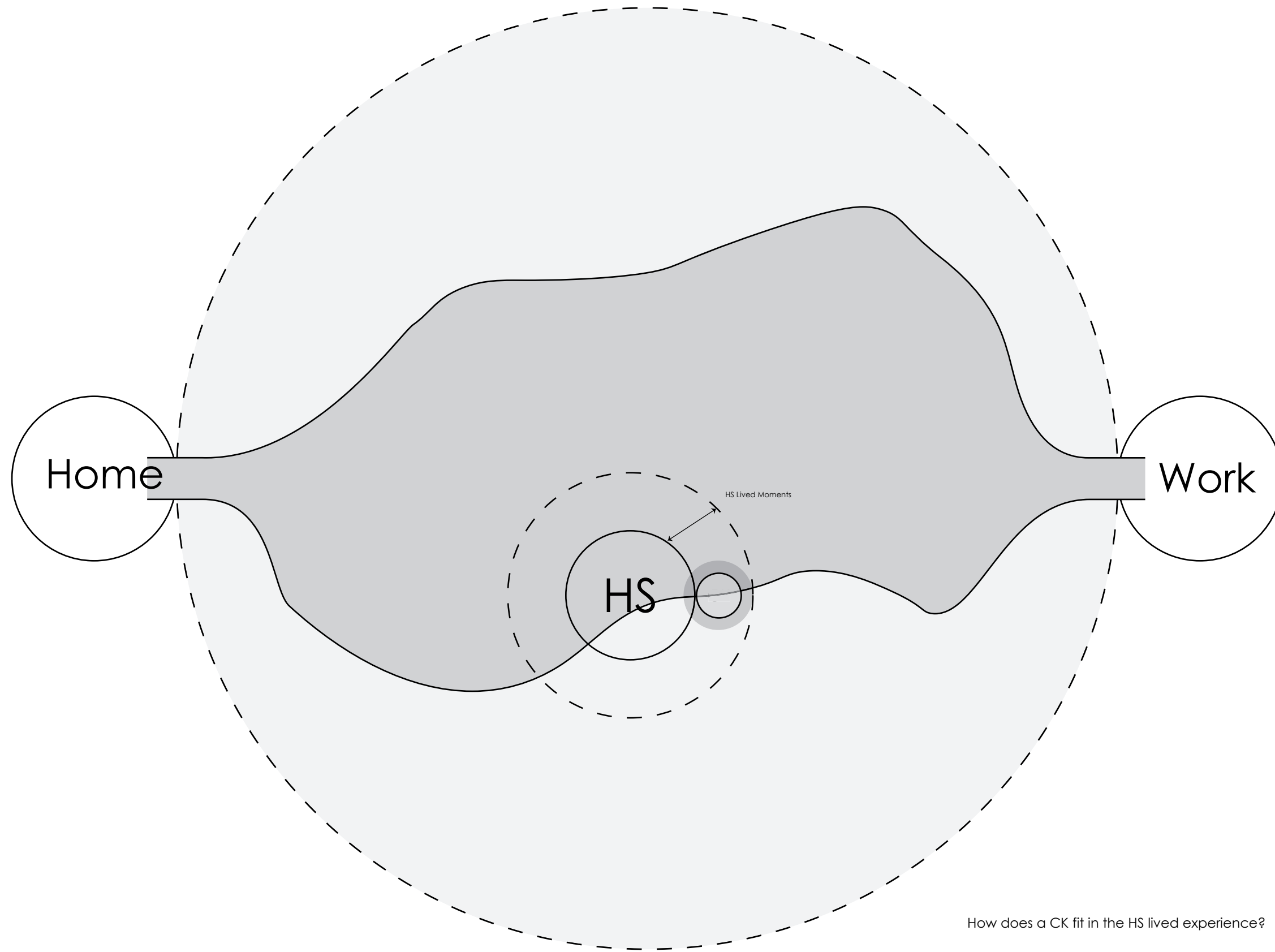

Social space becomes apparent after a transition, a possibility

Threshold is transition spatialized

Variation
intimacy and intensity
movement
control/domination
freedom of choice
complexity/curiosity
everyday rhythms

Social space becomes apparent after a transition, a possibility

Threshold is transition spatialized

Variation
intimacy and intensity
movement
control/domination
freedom of choice
complexity/curiosity
everyday rhythms

Social space becomes apparent after a transition, a possibility

Threshold is transition spatialized

Variation
intimacy and intensity
movement
control/domination
freedom of choice
complexity/curiosity
everyday rhythms

Rhythm of possibilities

Urban analysis

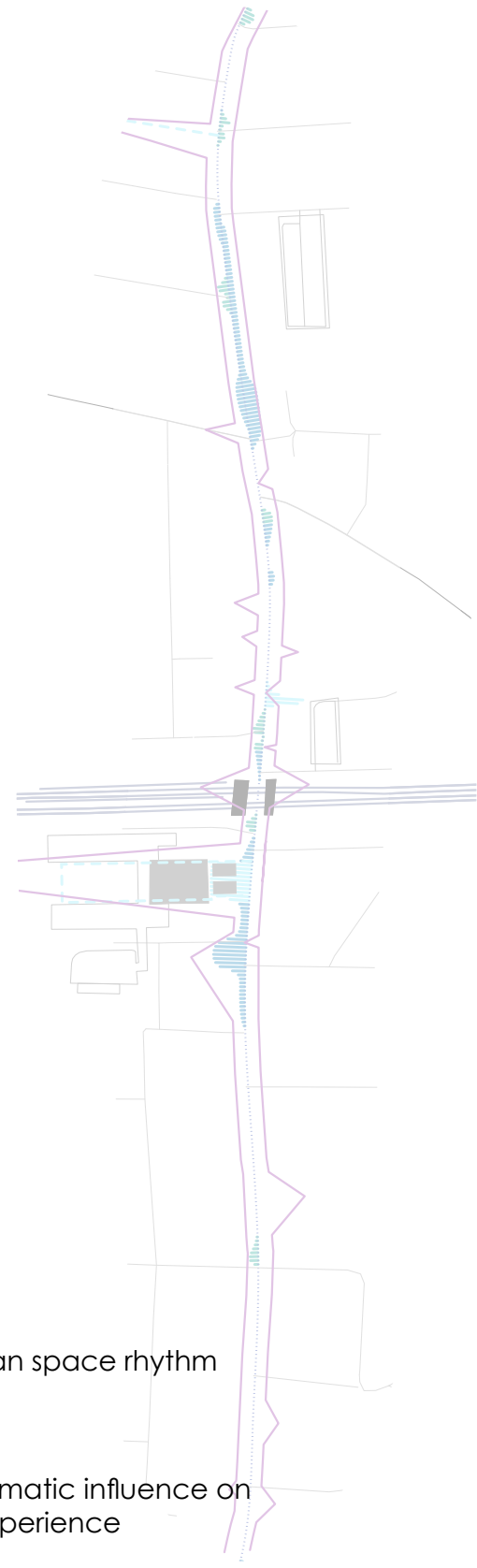

Green Street



Walworth Rd.

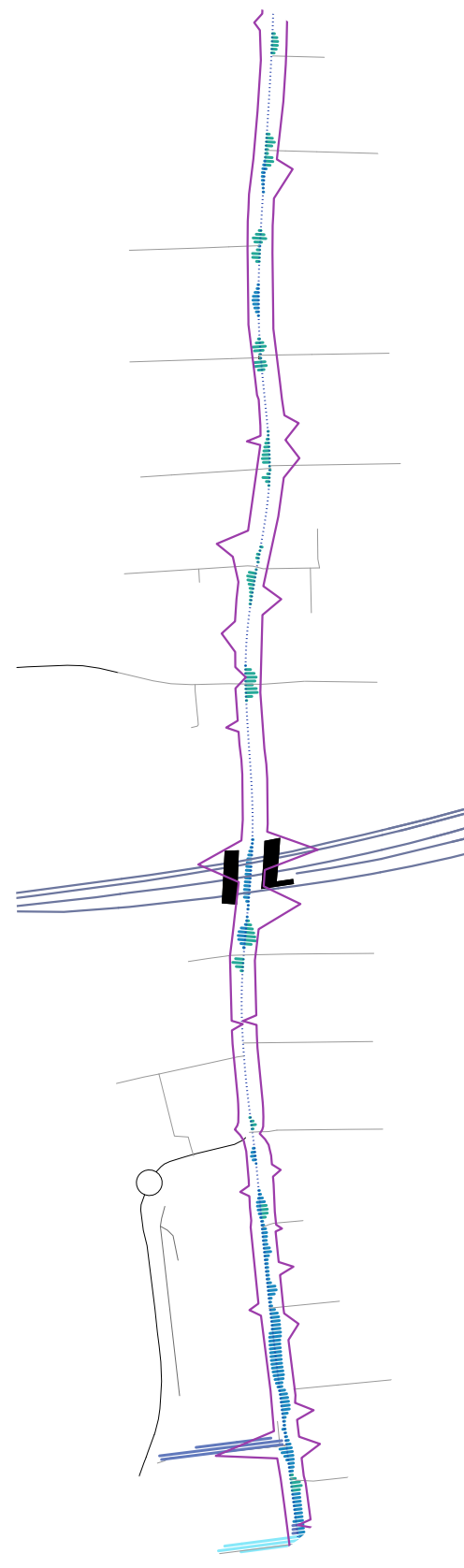

High Street

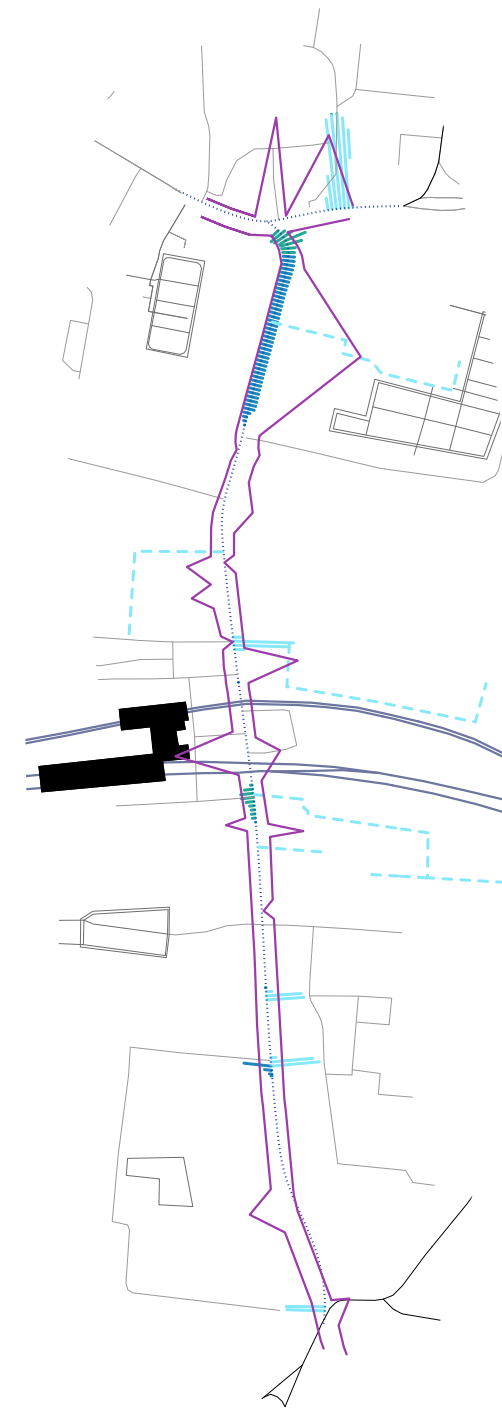

Rye Lane

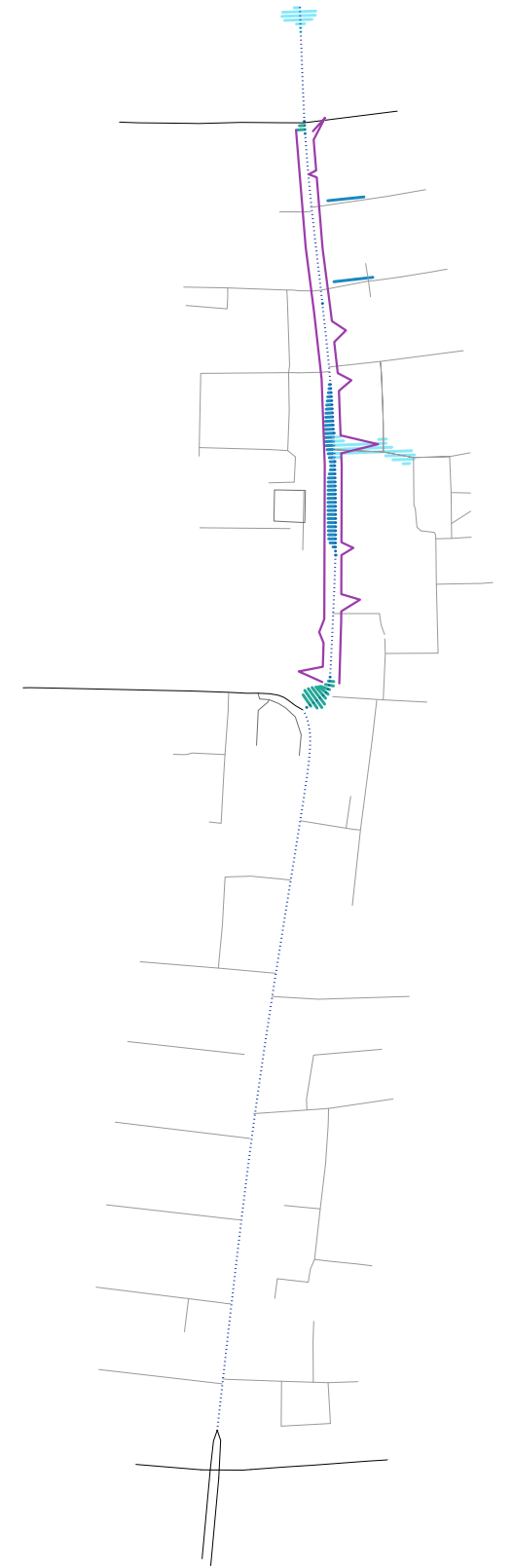

Roman Rd.

 Pedestrian space rhythm
 Programmatic influence on social experience

Routes

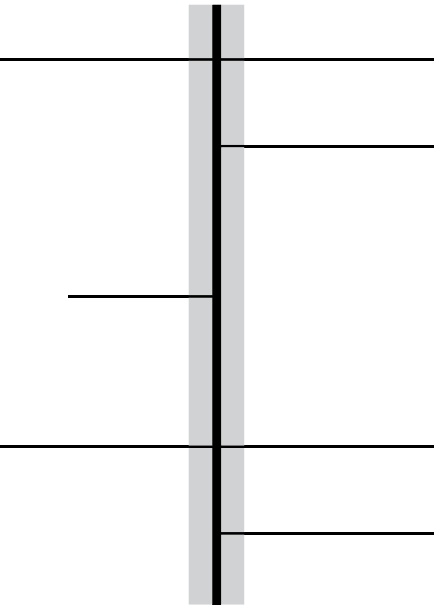

straight

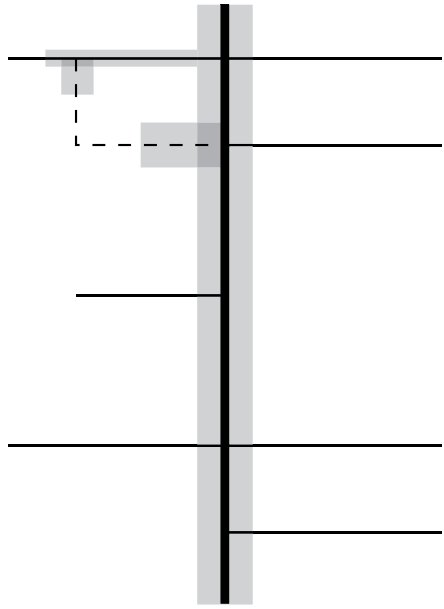

connector

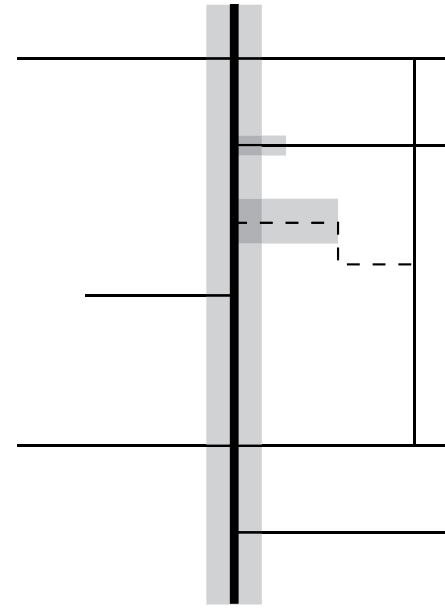

Deviator

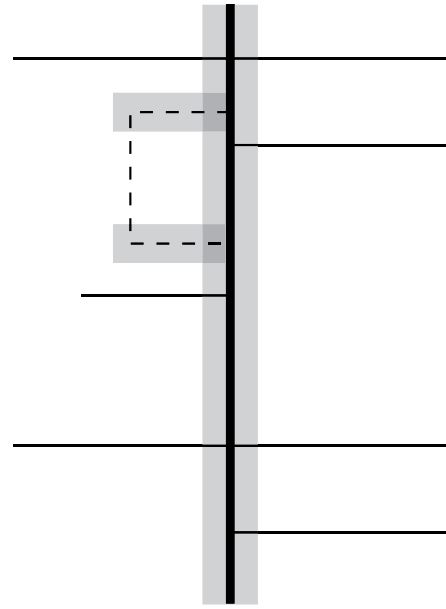

Circulator

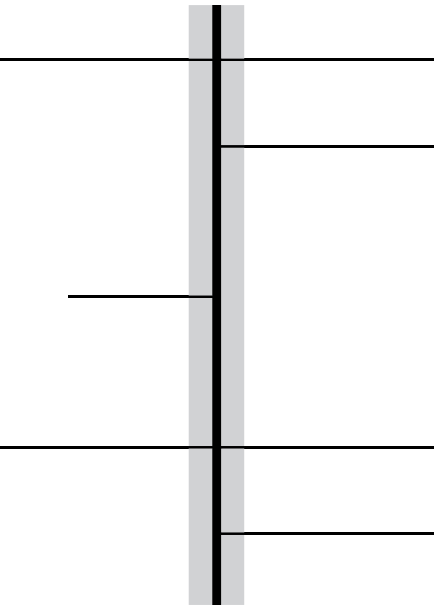

straight

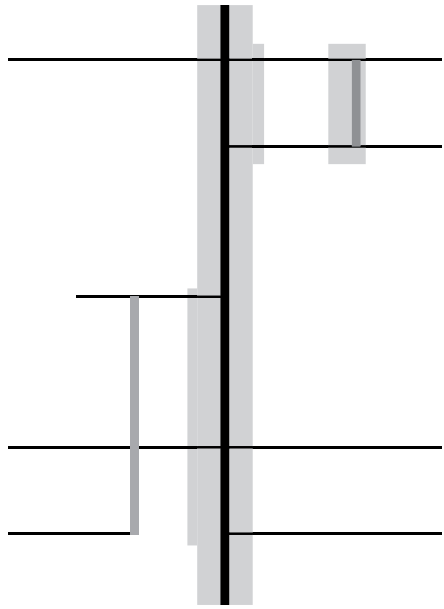

zig zag

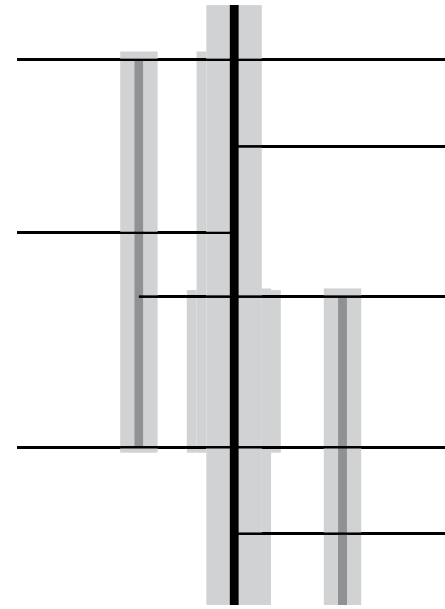

Choice

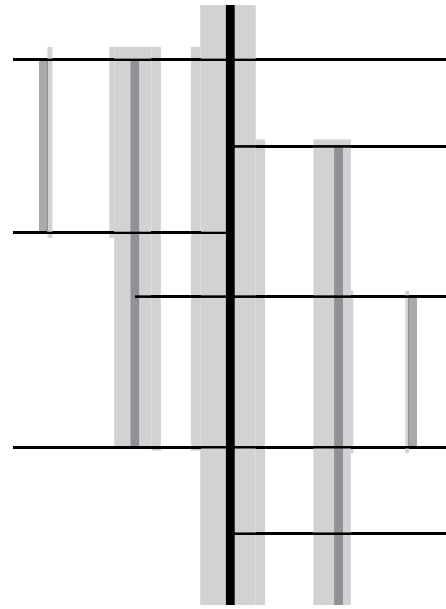

Gradient

Rhythm of operations

Rhythm of pedestrian types

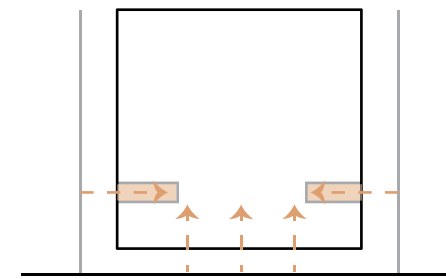

Sidestreet and front Organisational space

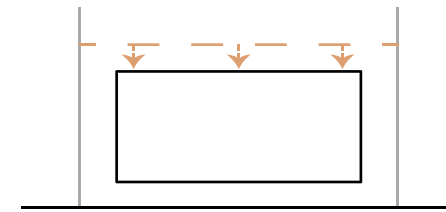

Backstreet organisational space

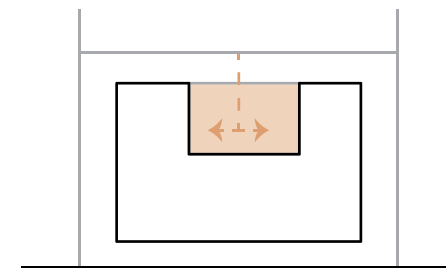

Redirected organisational space

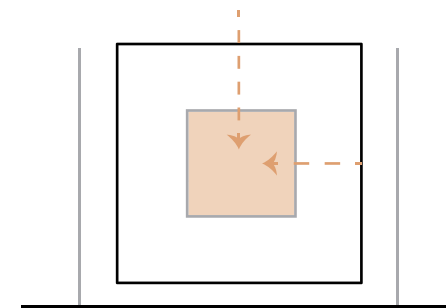

Hidden courtyard organisational space

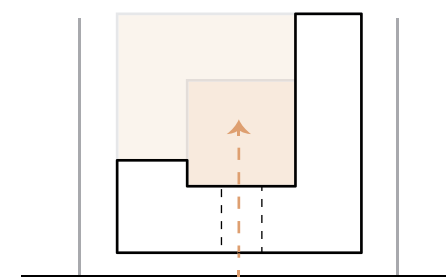

High street accessible organisational space

side street

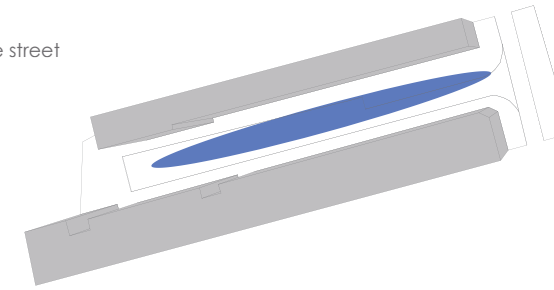

corners

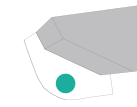

sidewalk

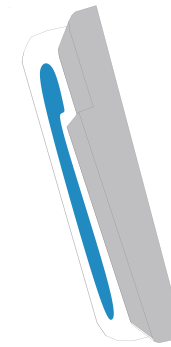

Deviated

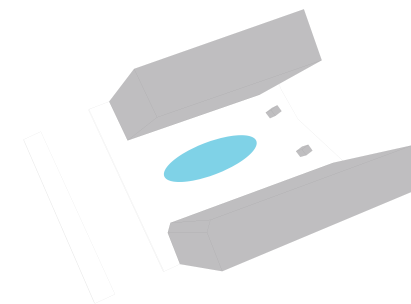

What is the lived value of these rhythms?

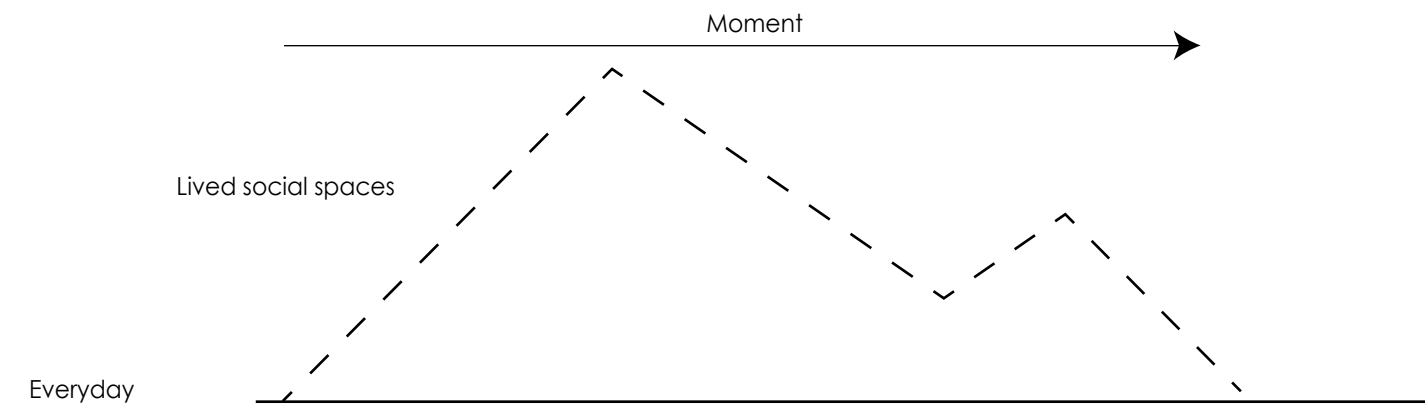
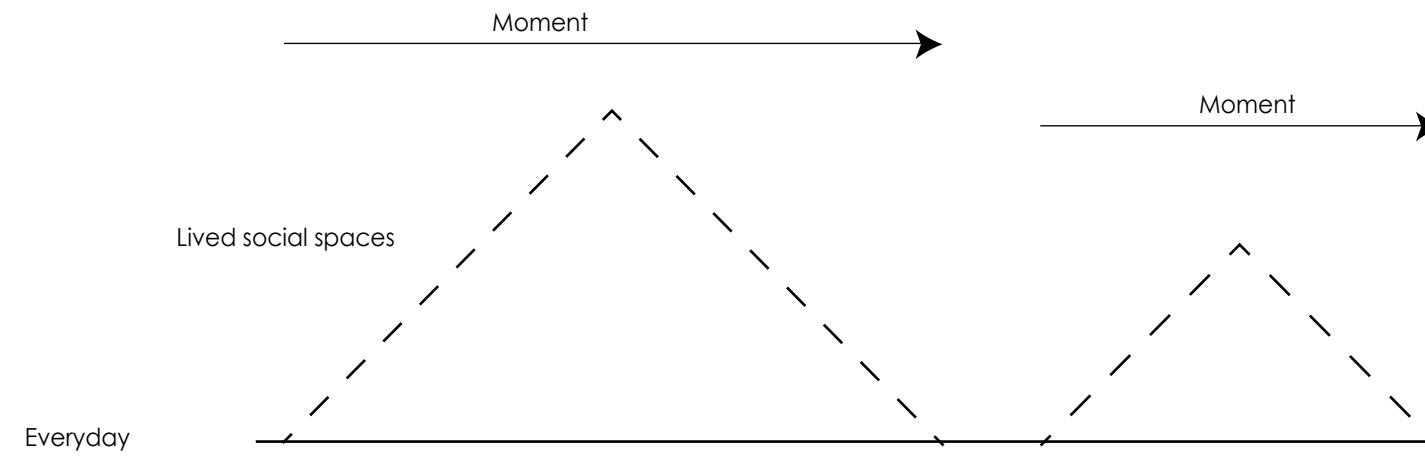

Which rhythms occur additionally?

CK perspective

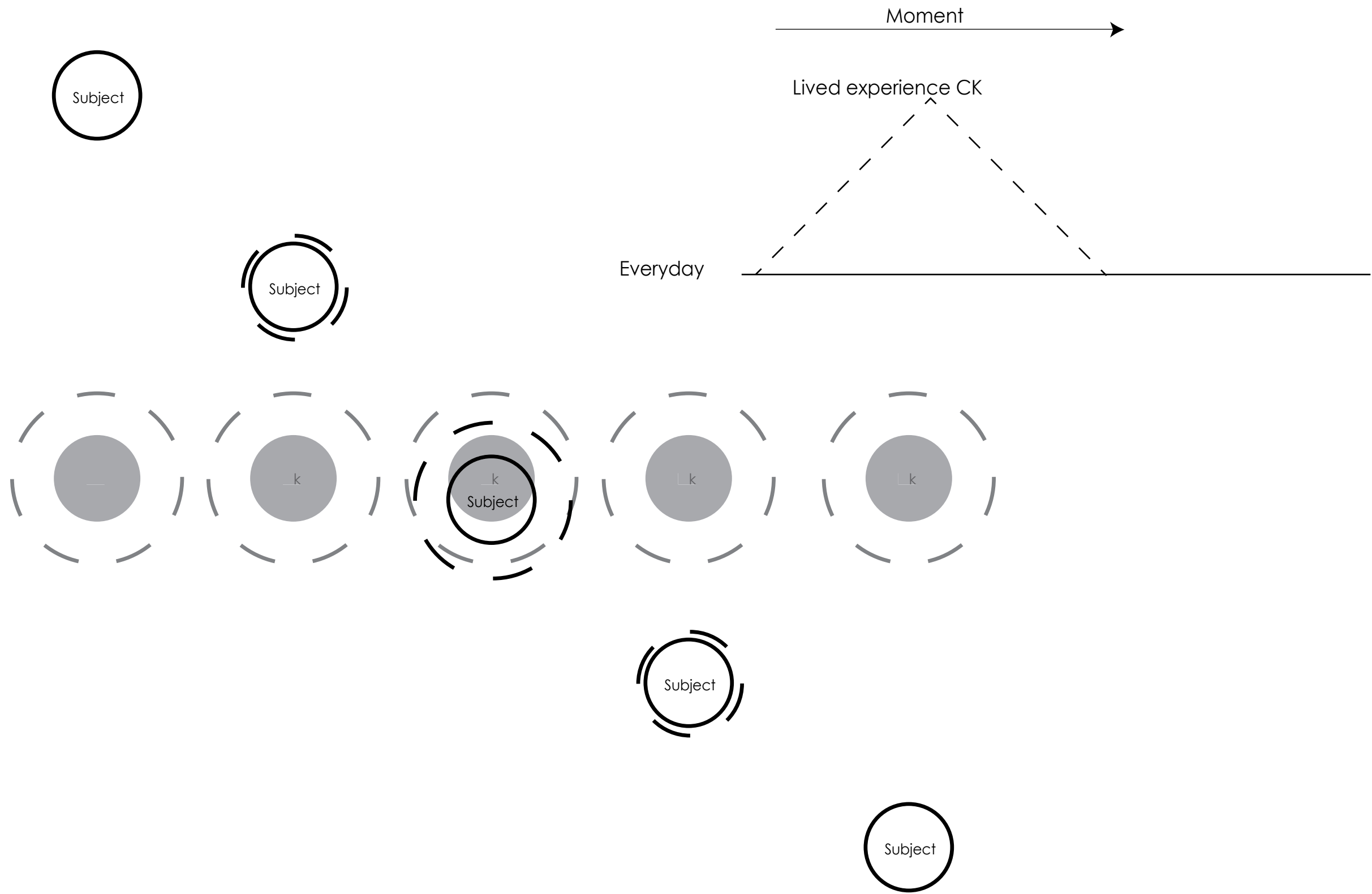

Privacy

Freedom of choice

Accessibility

Reasons of participation

The varying rhythms of participants and volunteers

the rhythm of the ritual

The interior position of the kitchen

Micro Transitions

inside - outside transition

Building

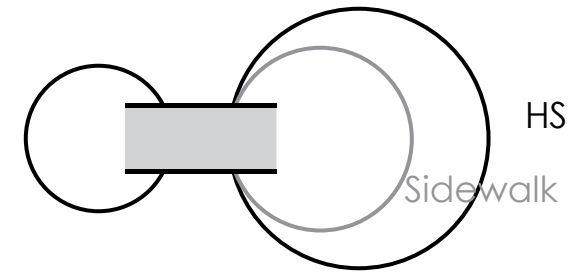

On high street transition

Sidewalk

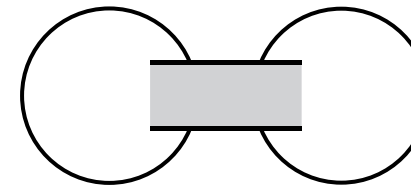

Sidewalk

Temporarily off - on transition

HS

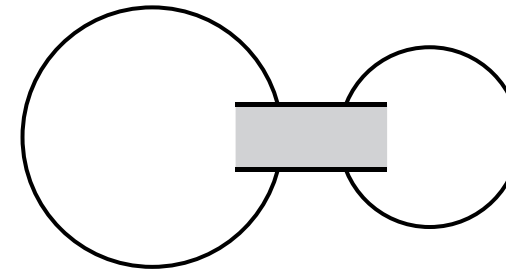

Deviated spaces

On - off high street transition

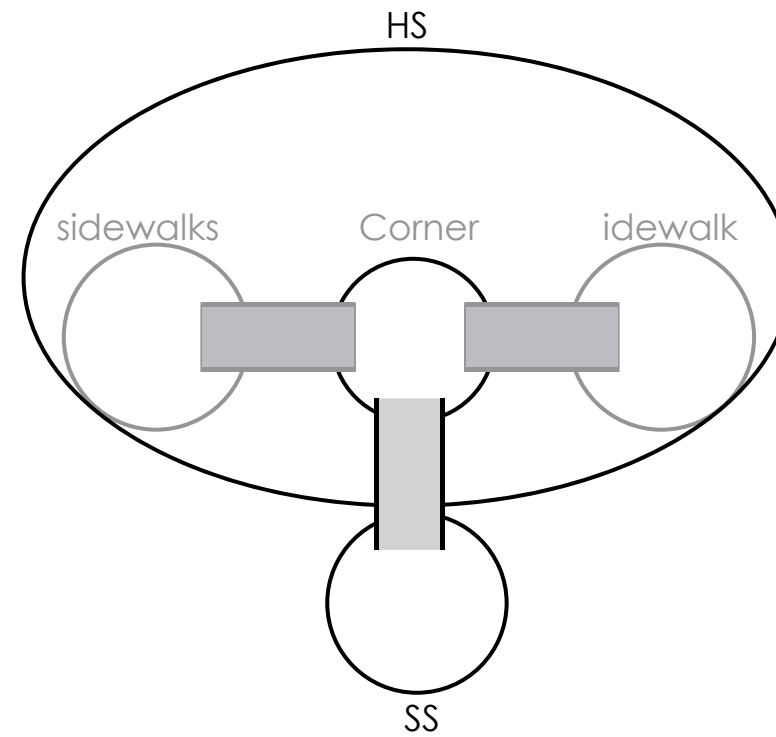

Anonymity



Anonimity among the many

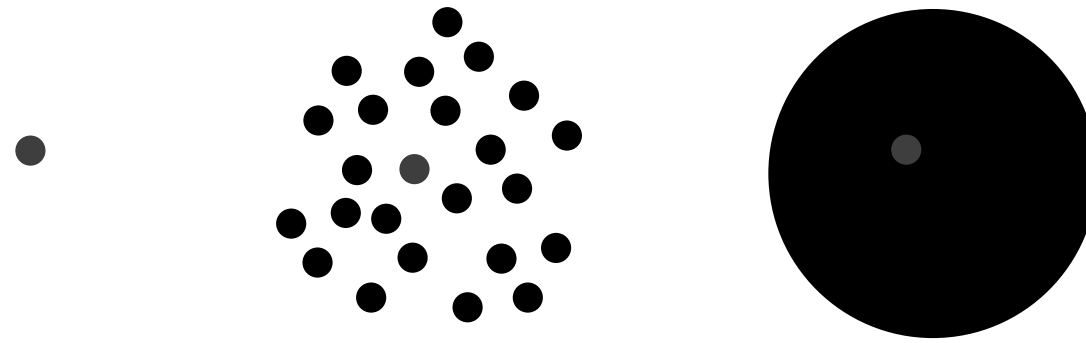

moment nullified

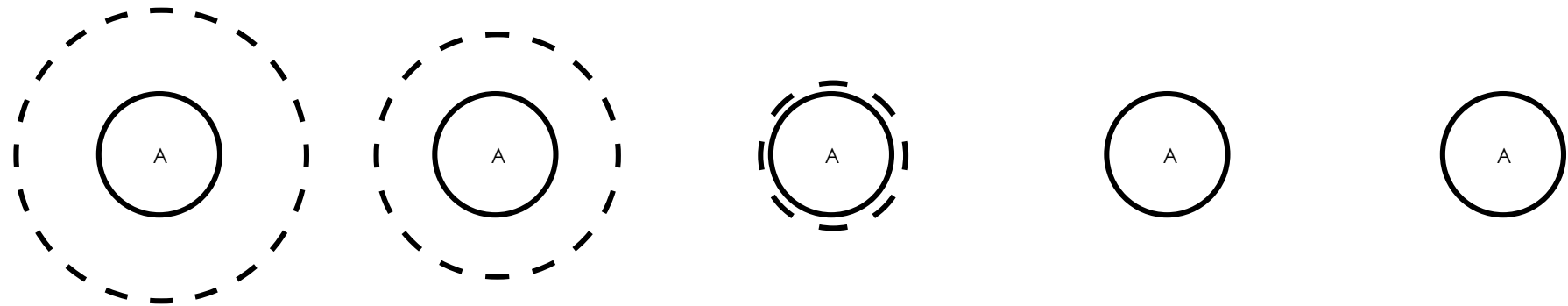

Variation



closed facade
social space

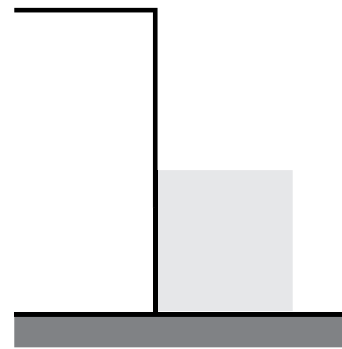

the exception among the many

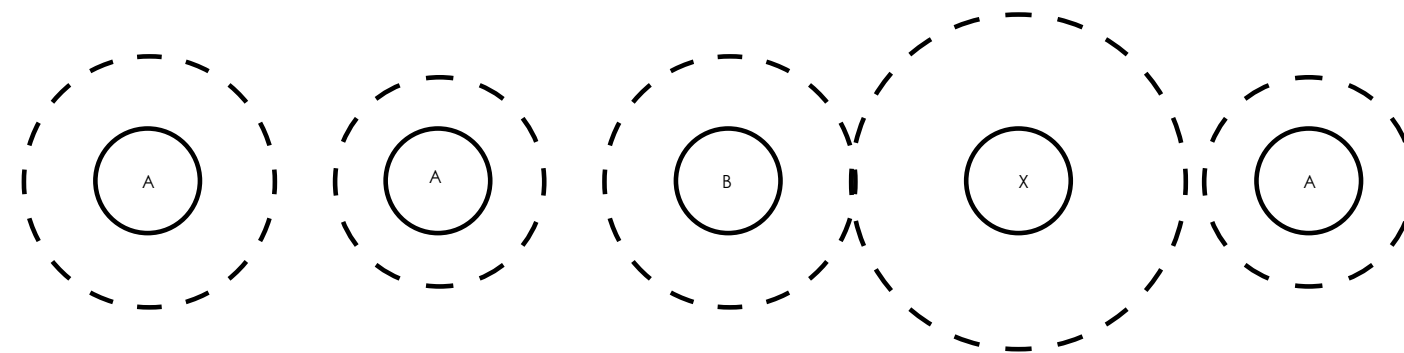
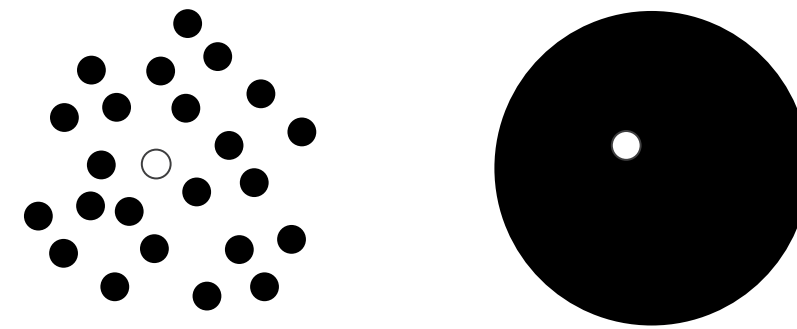

unique/maintaining

Direction



Opening up,
gradually intimate

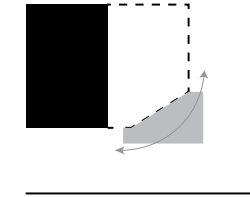
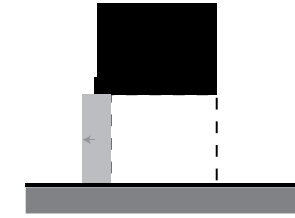

Encloser,
quickly intimate,
vertical divider

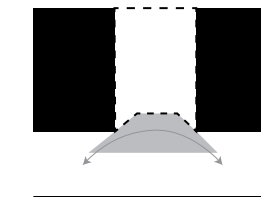

Room

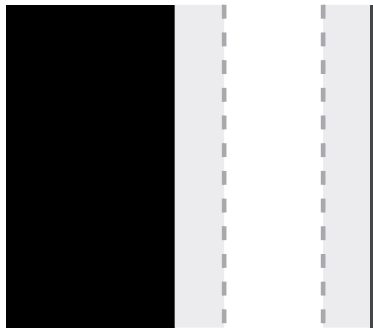

Pedestrian traffic



Street appropriation



Building appropriation



Sidewalk to be interpreted

?

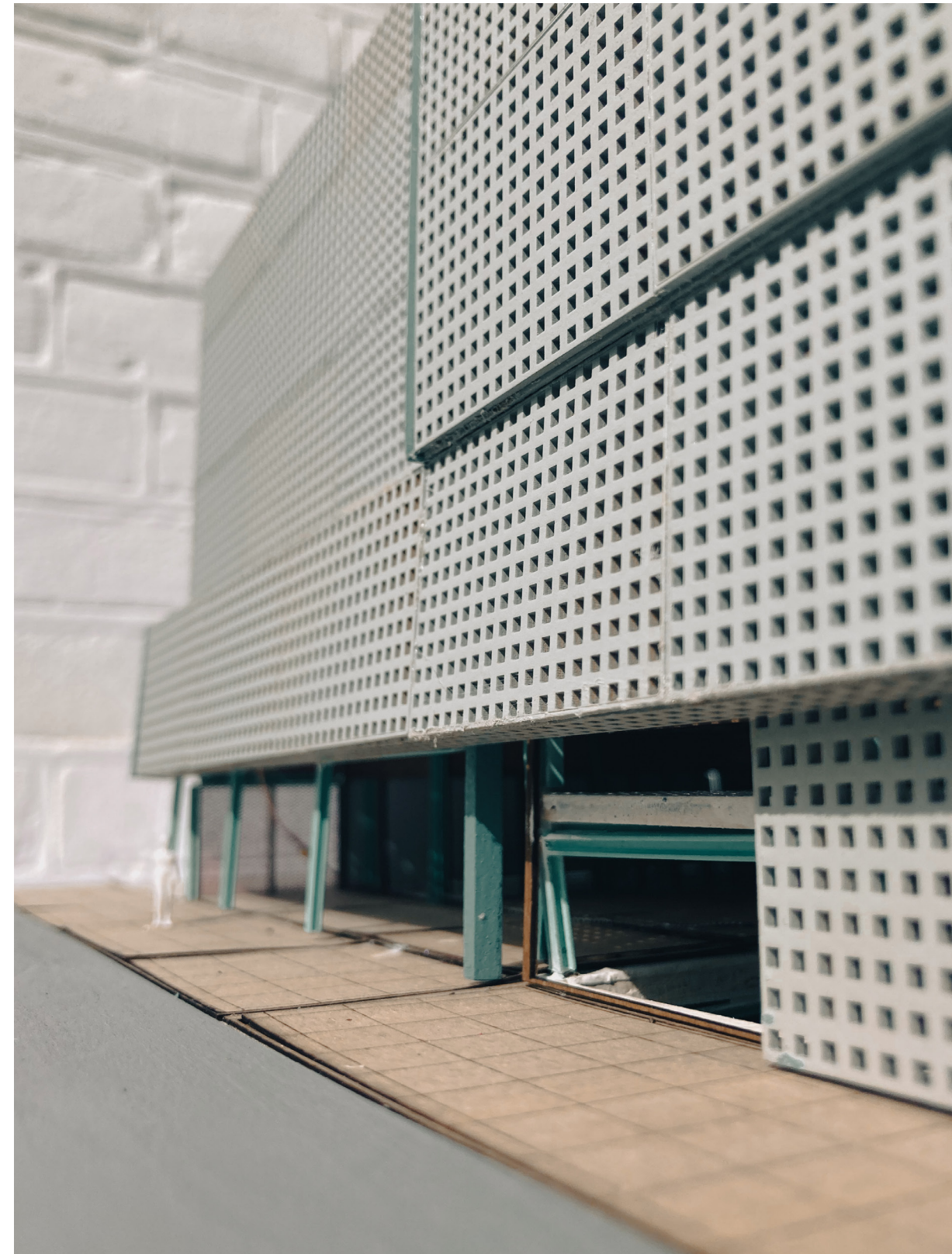

Reciprocity

Awning détournement, a reciprocative process

s

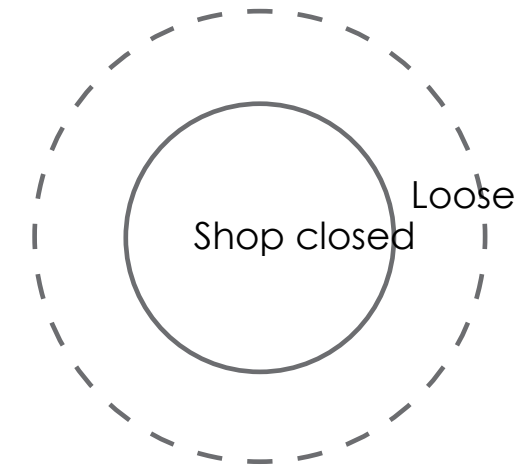
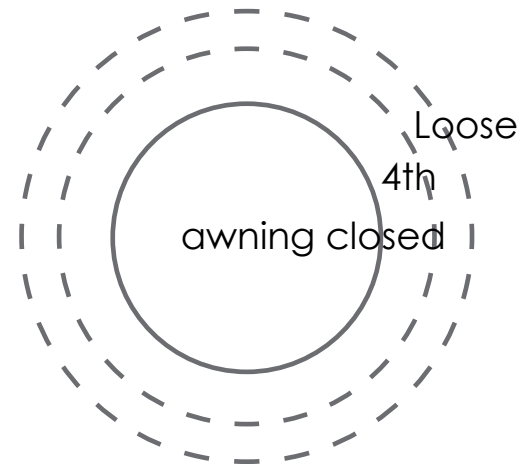
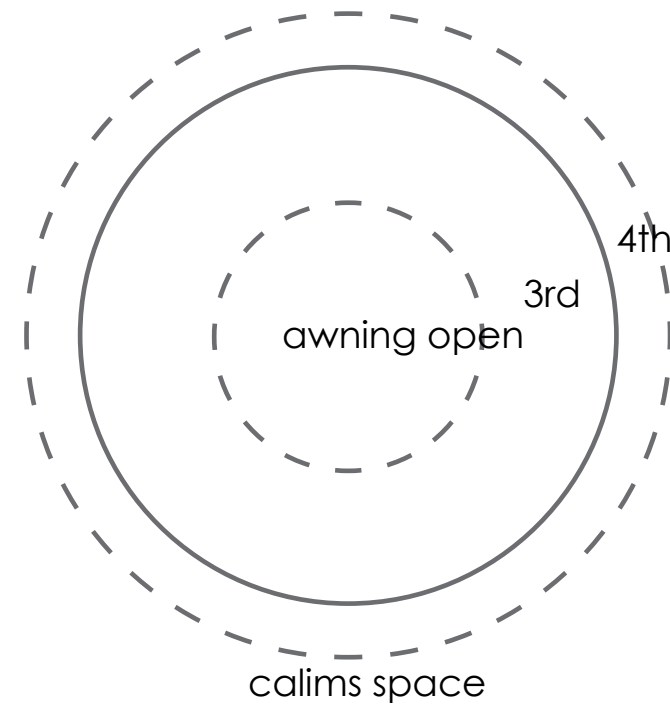

space given back



Unity of facades

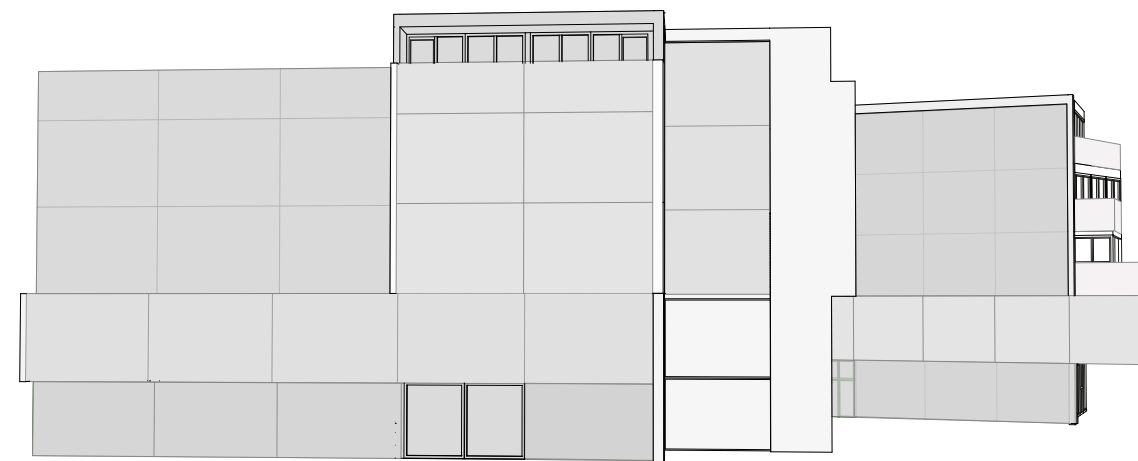

Turn on the light



dominance lessend because of light



seating centered around low threshold
public programs



border of light

Change of activity

light and activity emphasis

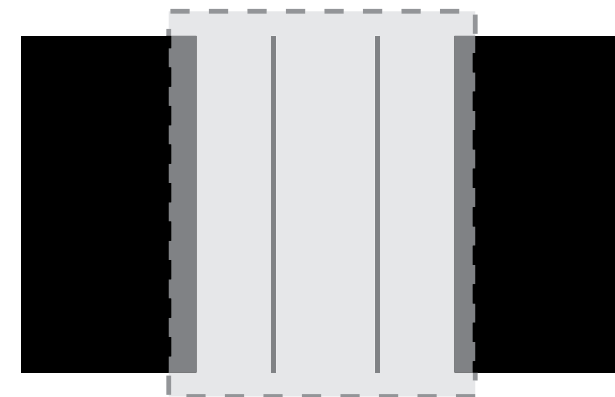

Day

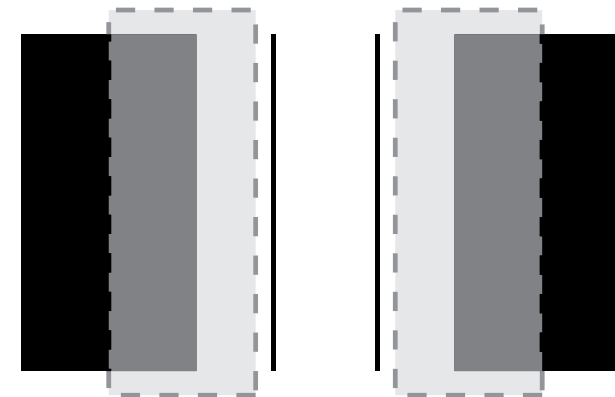

evening





To provide transition is to consider transitions

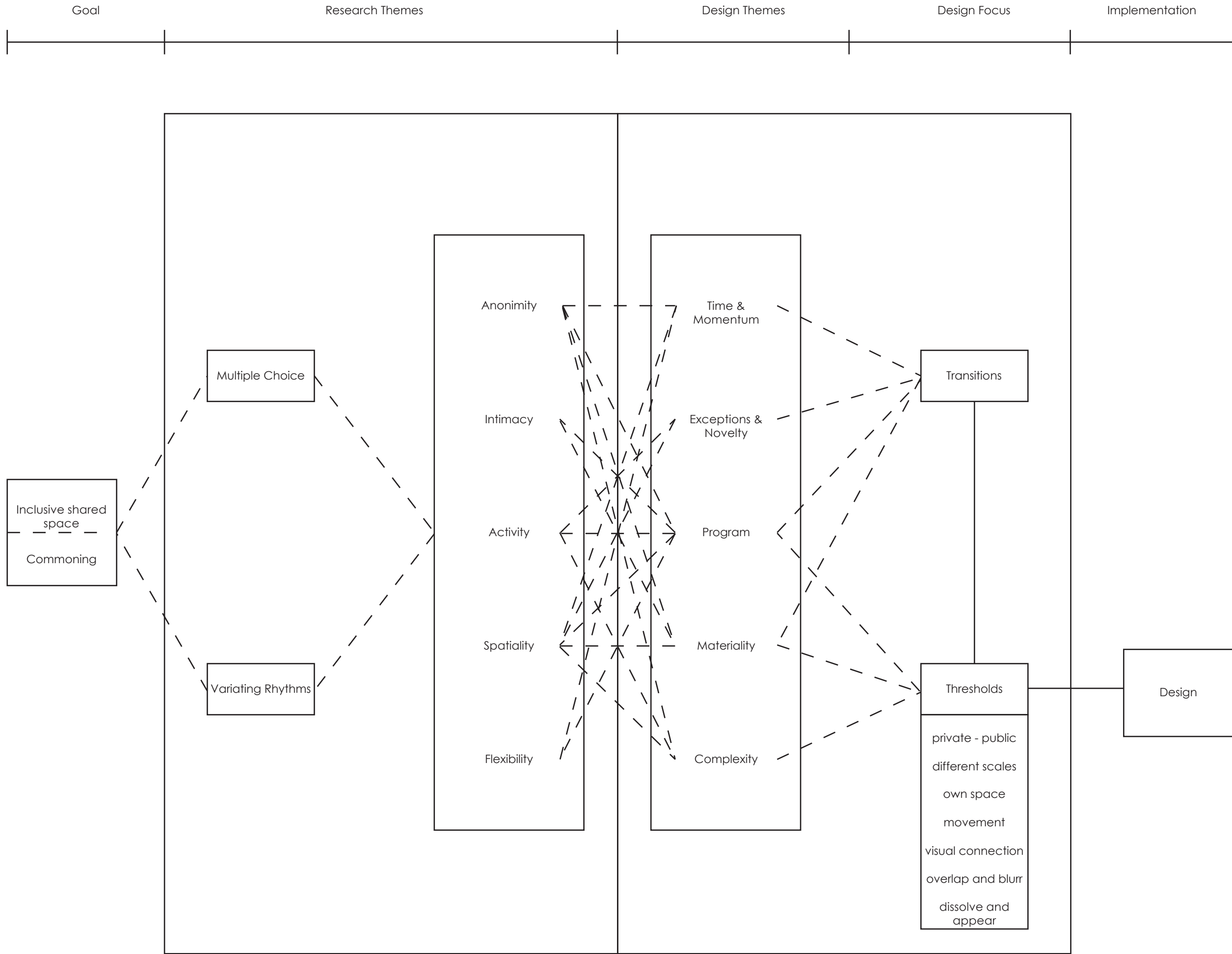

Design Goal

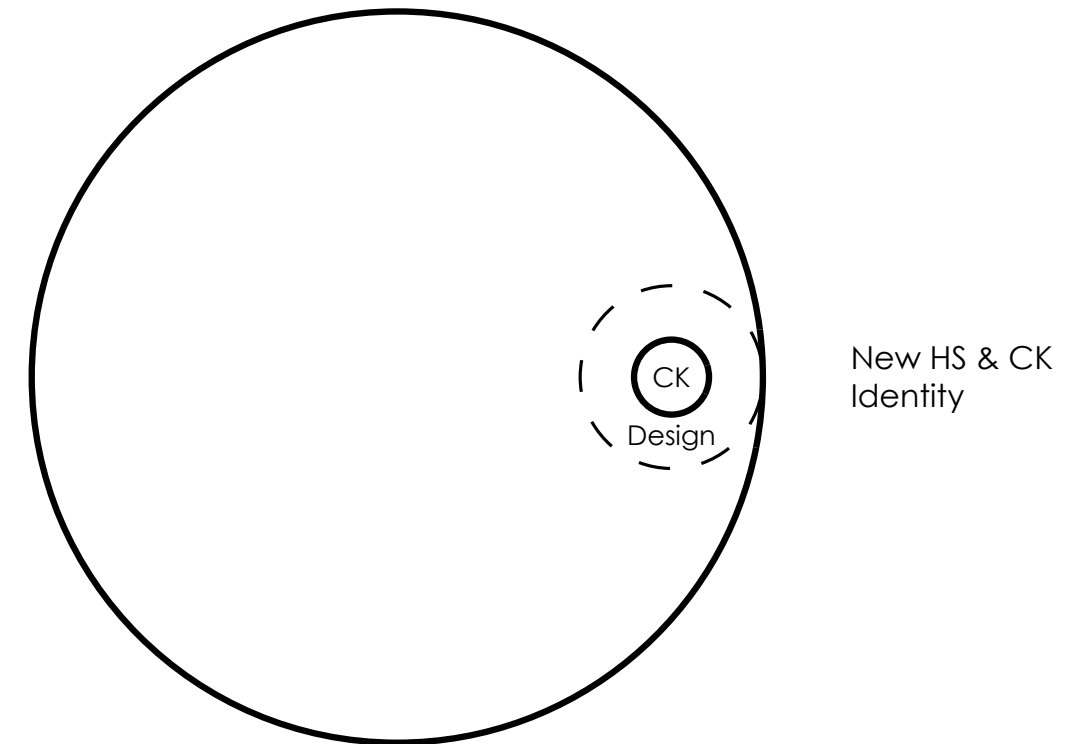
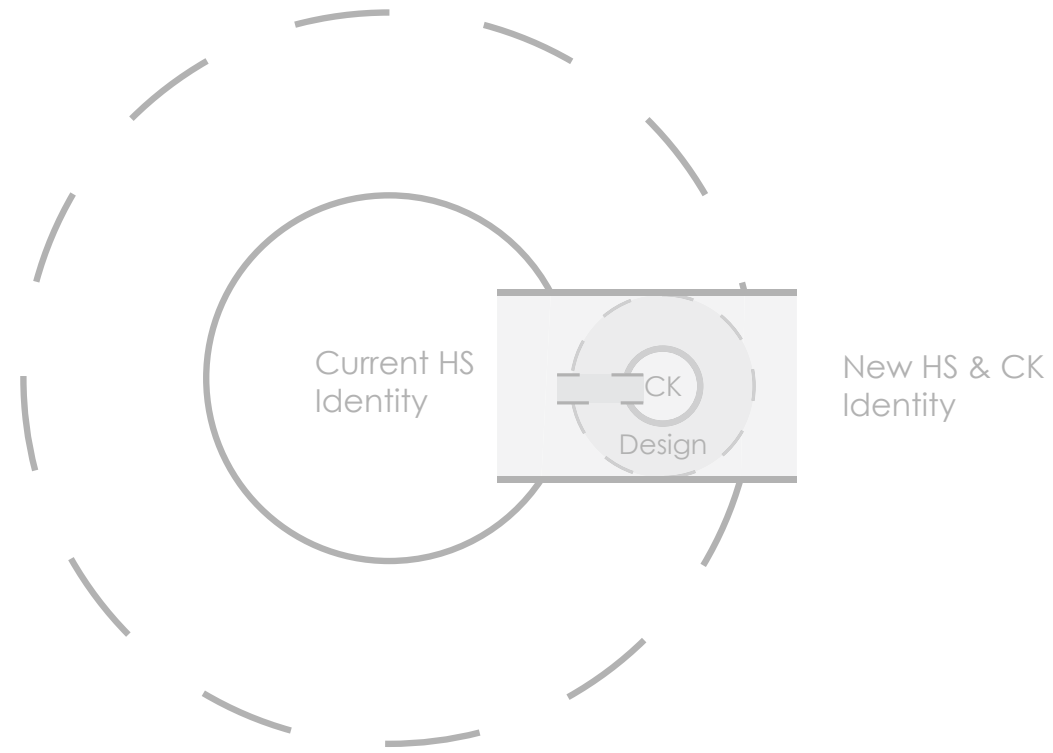
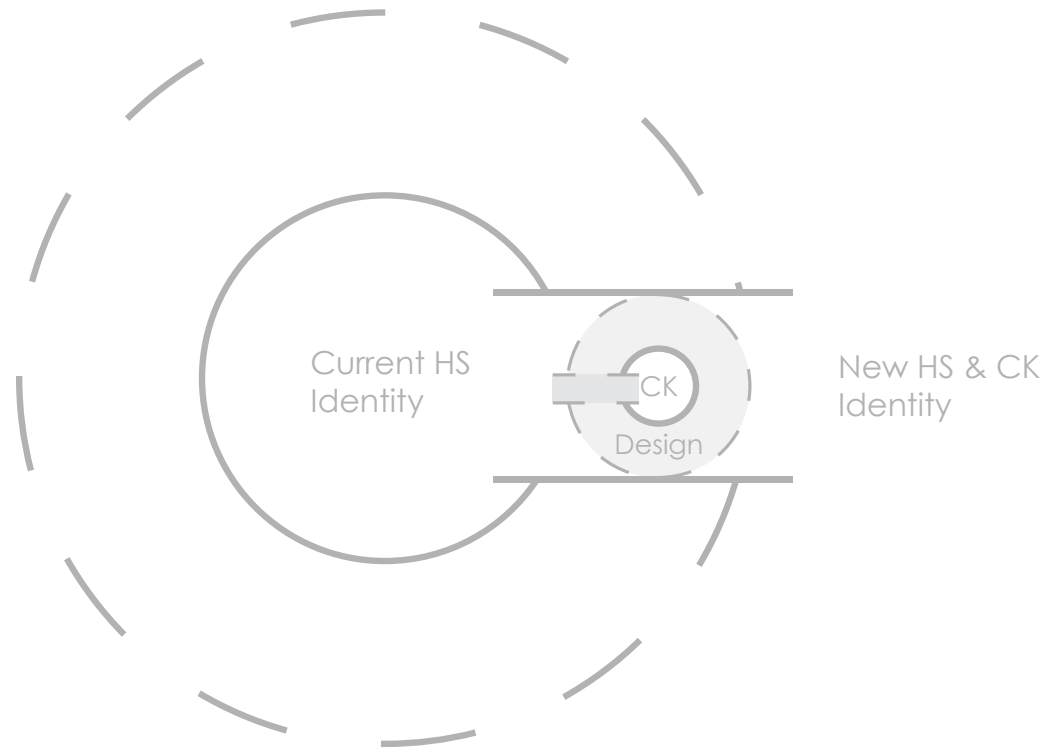
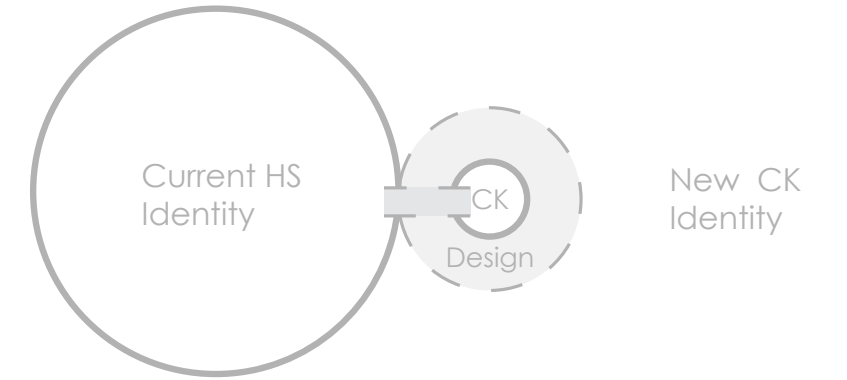
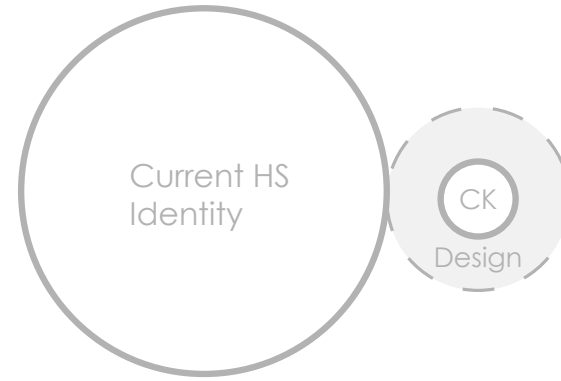
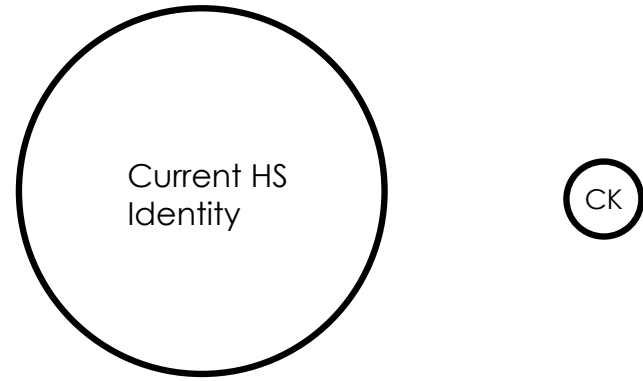

The Chosen Context





Programs

- regular shops
- indoor markets and supermarkets
- Religious programs
- Leisure
- Gambling
- Community programs





Programmatic influence on social experience



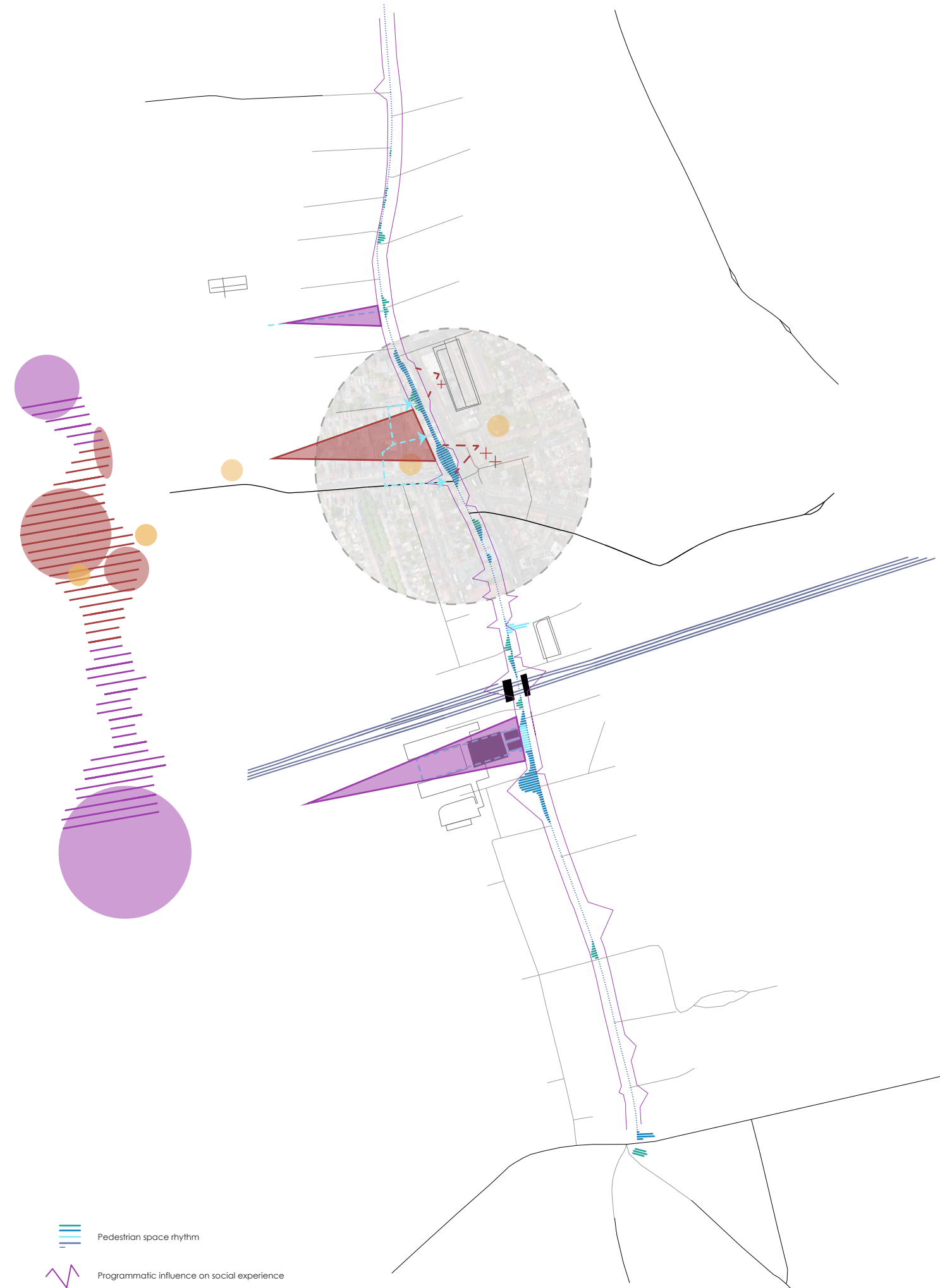

 Pedestrian space rhythm
 Programmatic influence on social experience

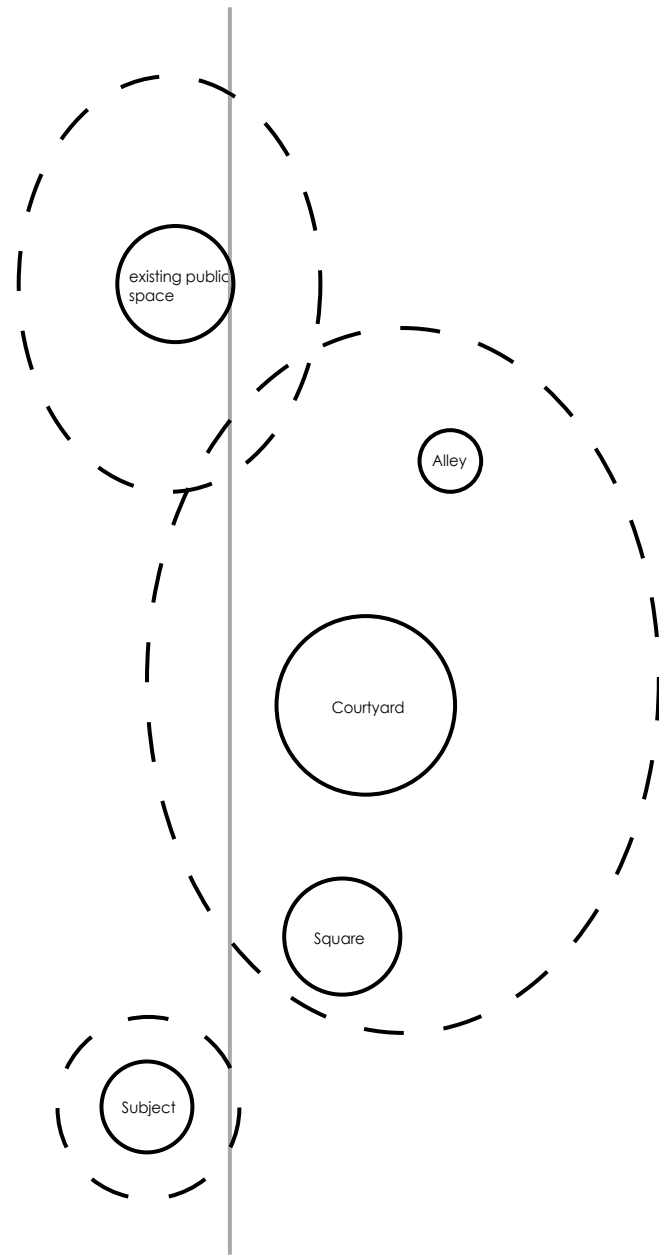

 Pedestrian space rhythm
 Programmatic influence on social experience

Part of the Urban Rhythm



 Pedestrian space rhythm
 Programmatic influence on social experience

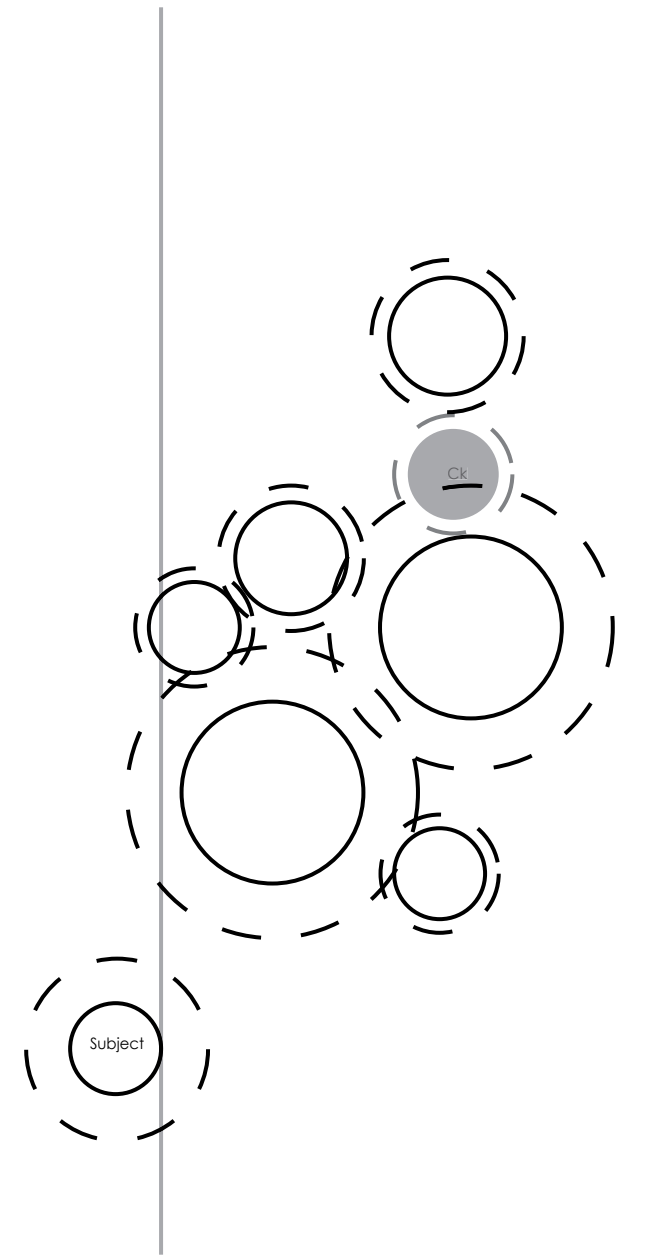

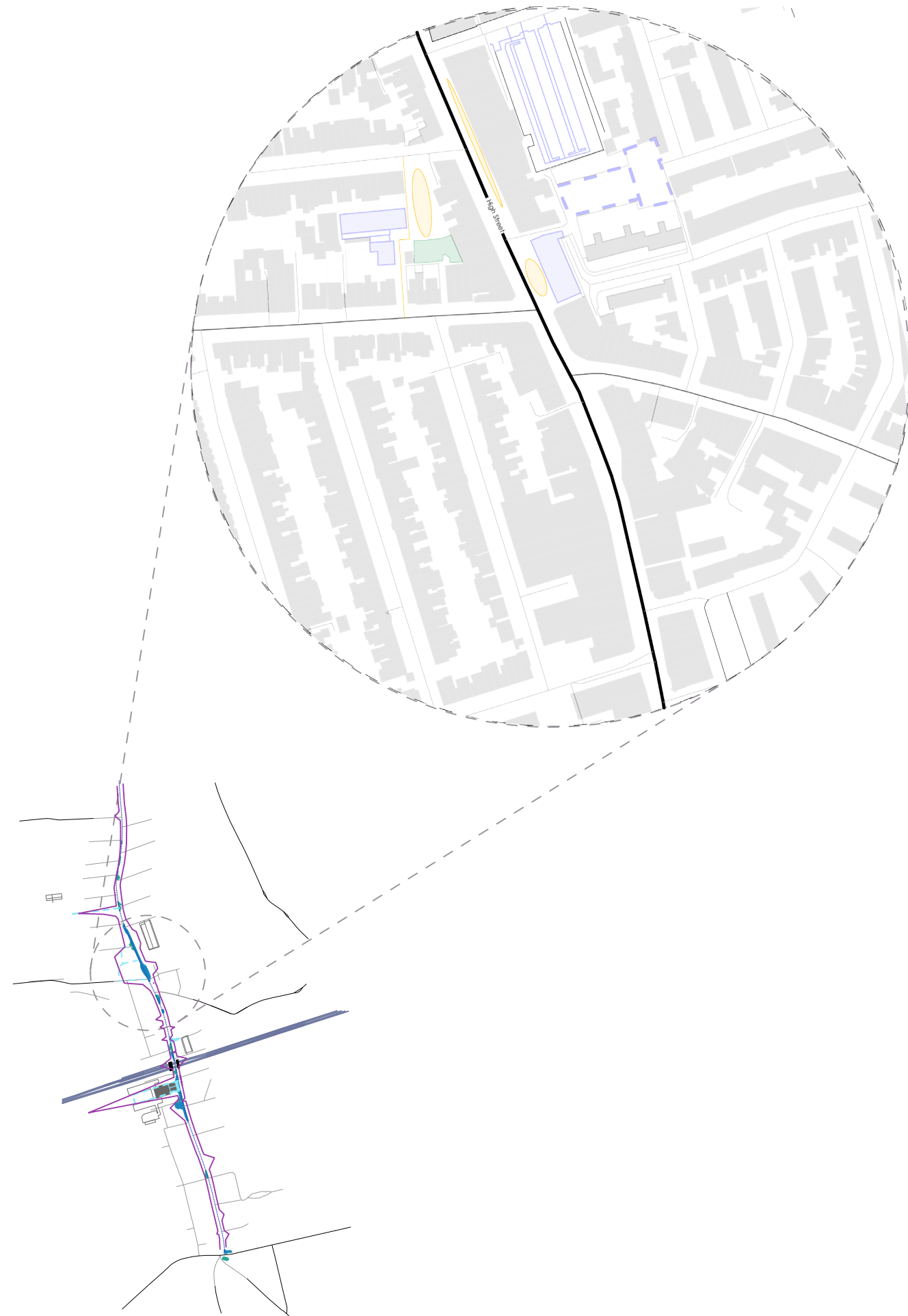



community garden

Oppurtunity buildings

Oppurtunity space

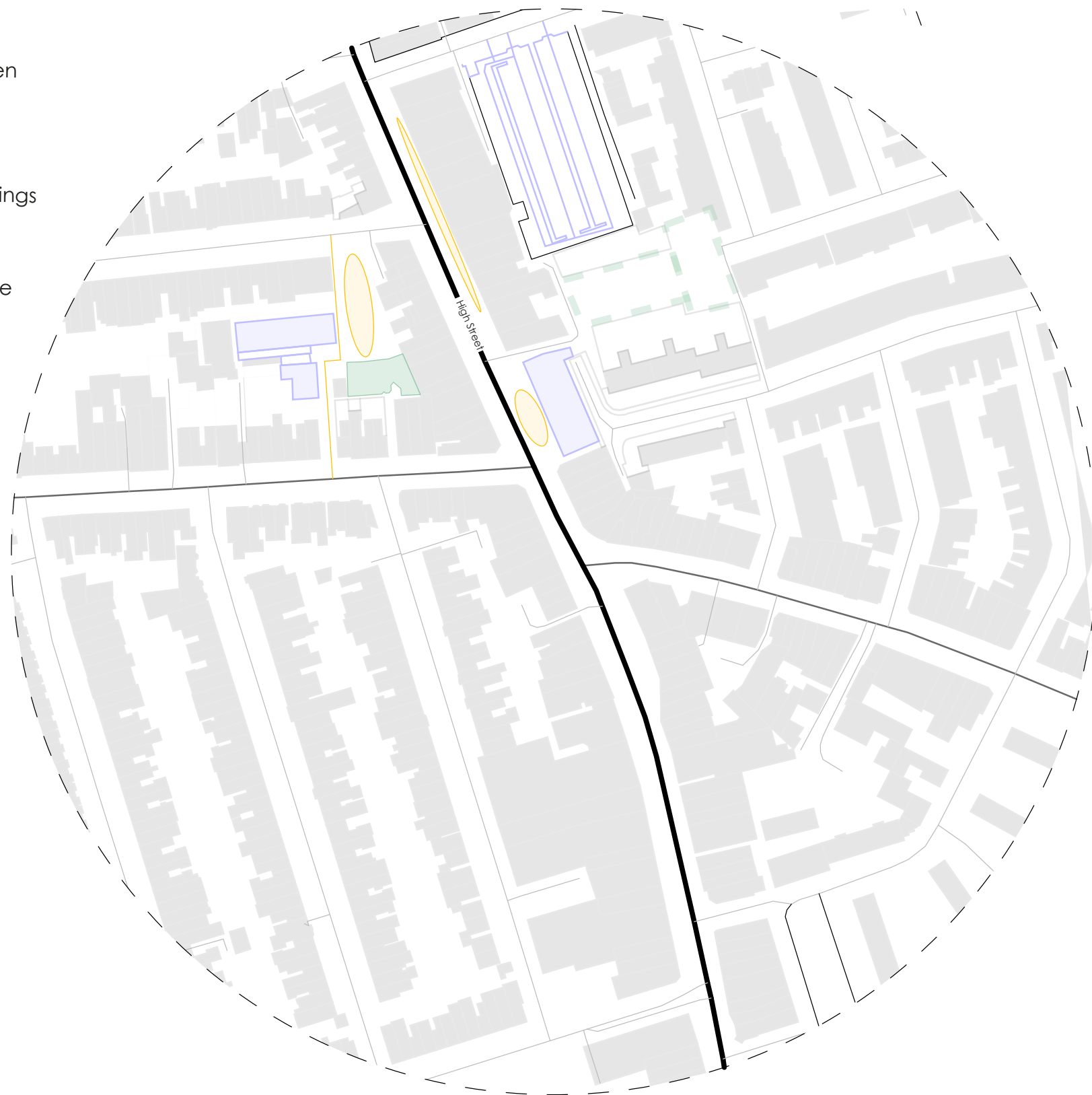
Mosque



 Pedestrian space rhythm



Remove



Re-use









Plot

Thresholds to consider

Project as threshold

High Street

CK

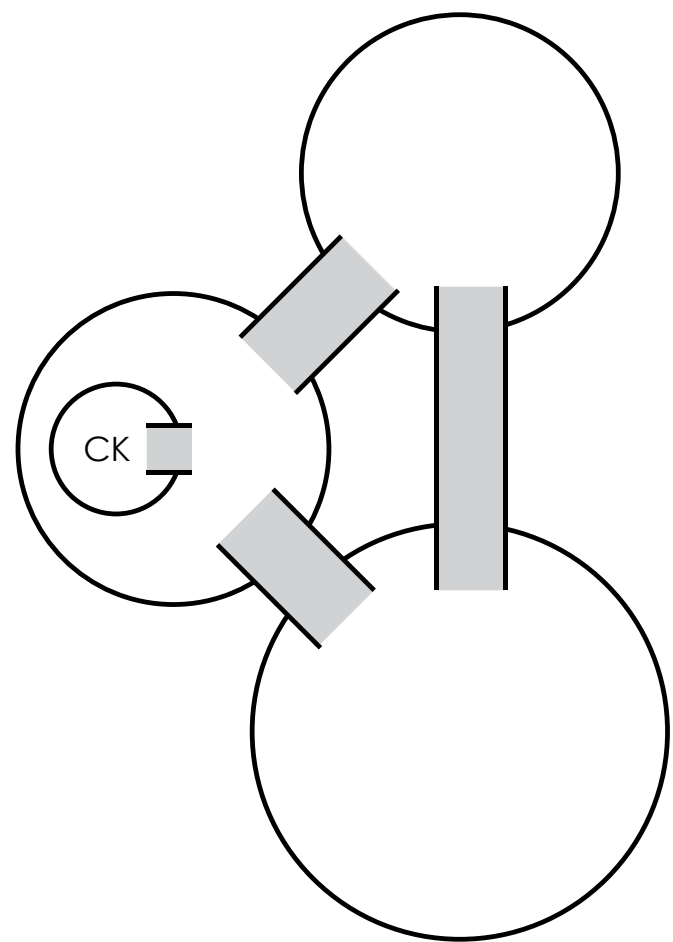

Neighbourhood/
communitiy

HS

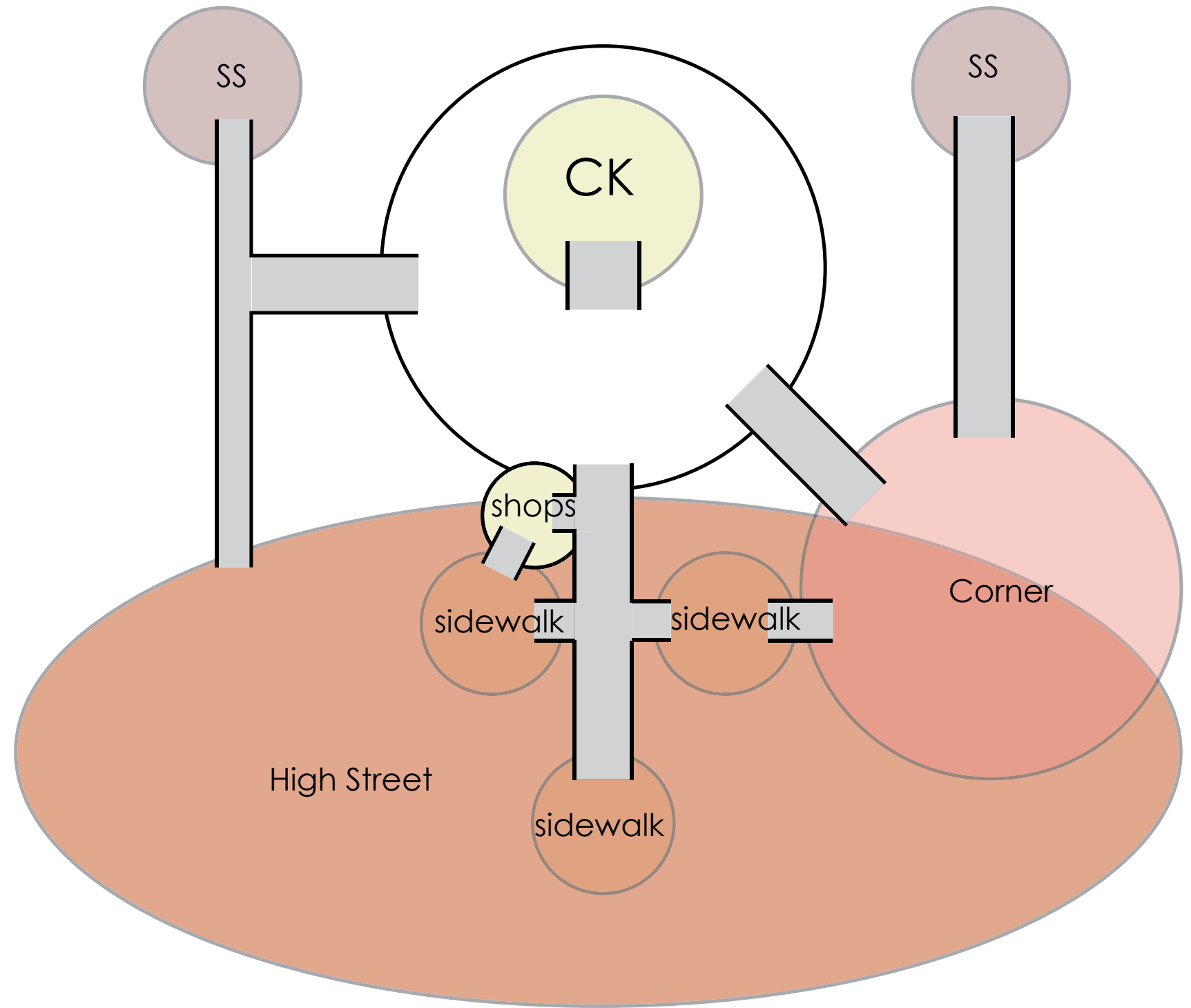

High Street

shops

sidewalk

sidewalk

sidewalk

Corner

SS

SS

CK



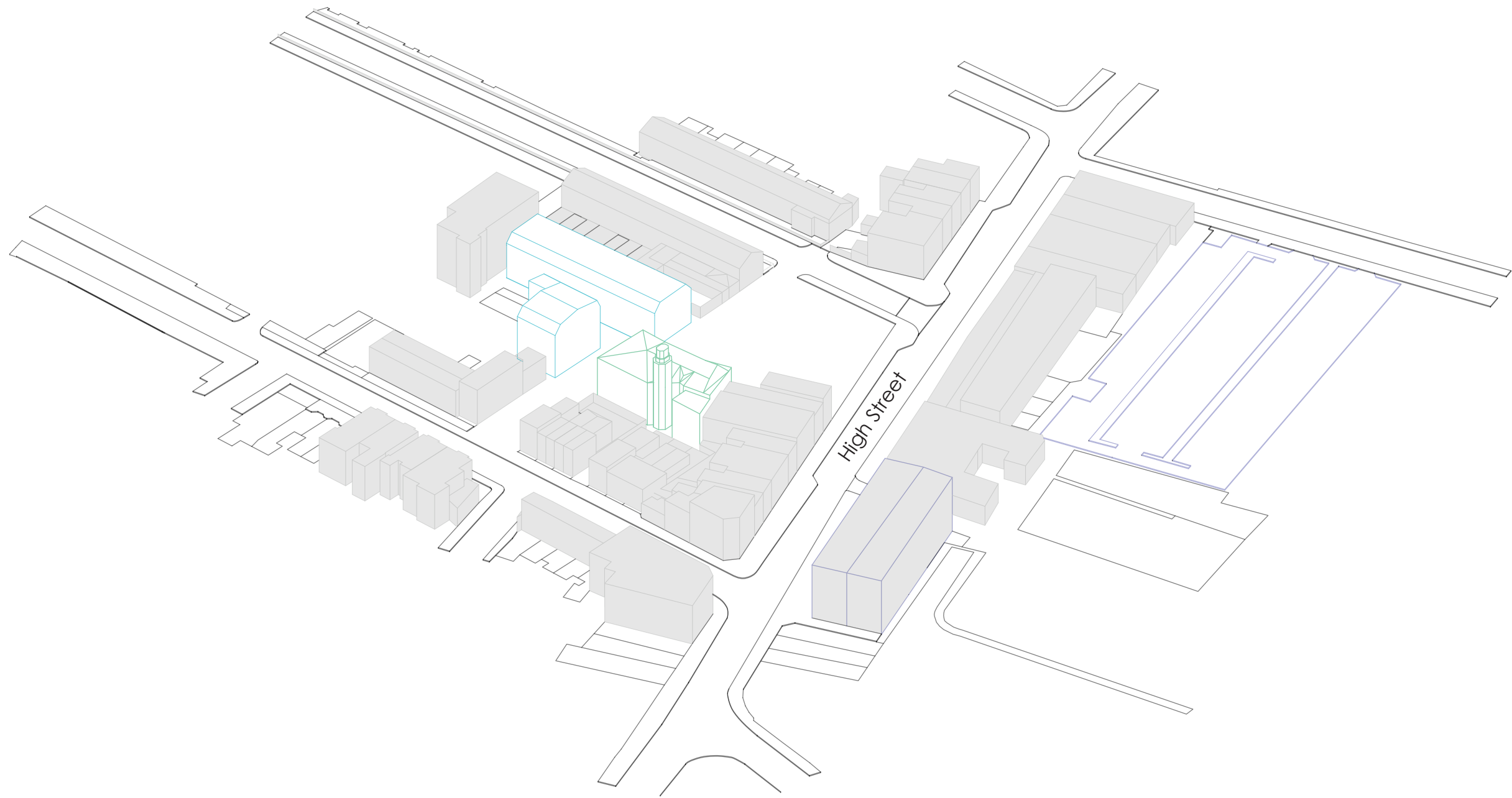

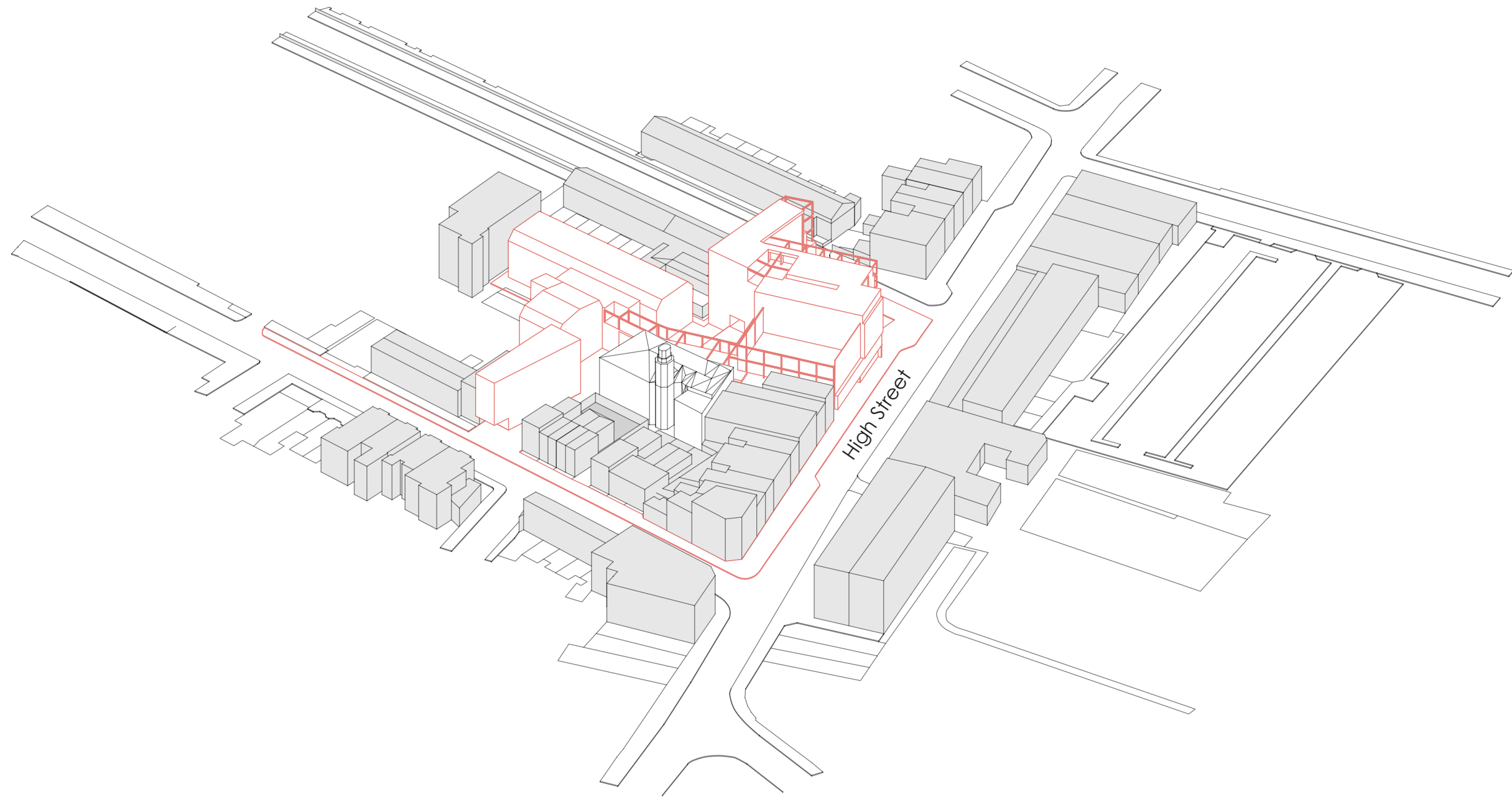

Articulation of spaces

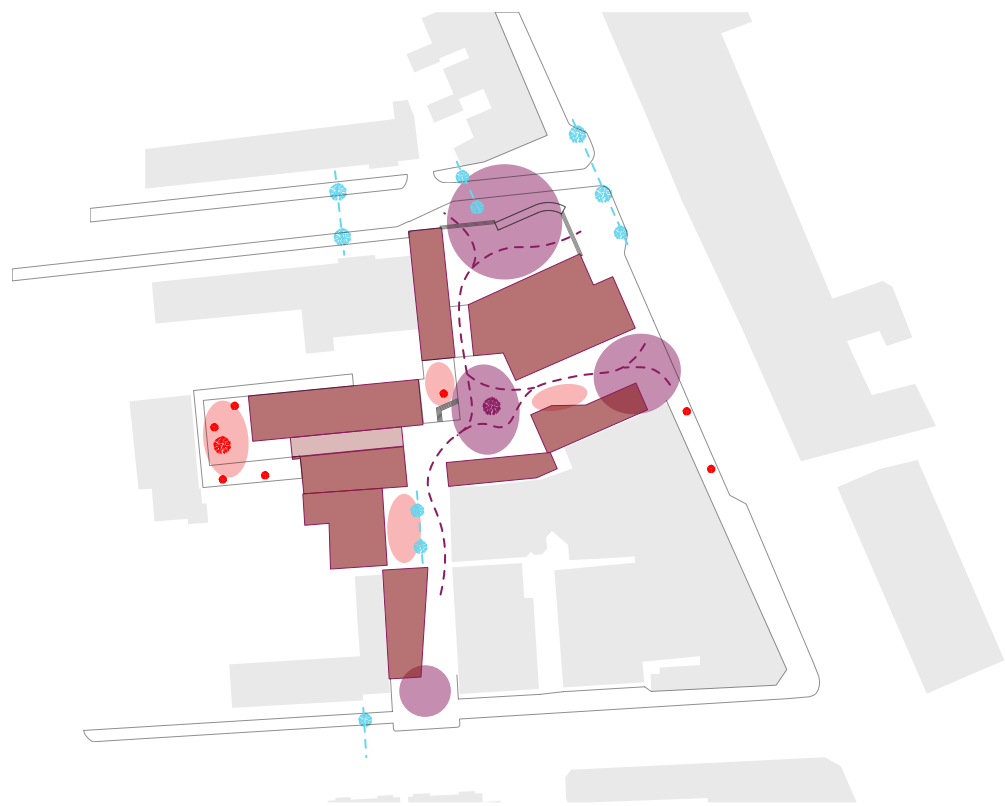

Degrees of intimacy

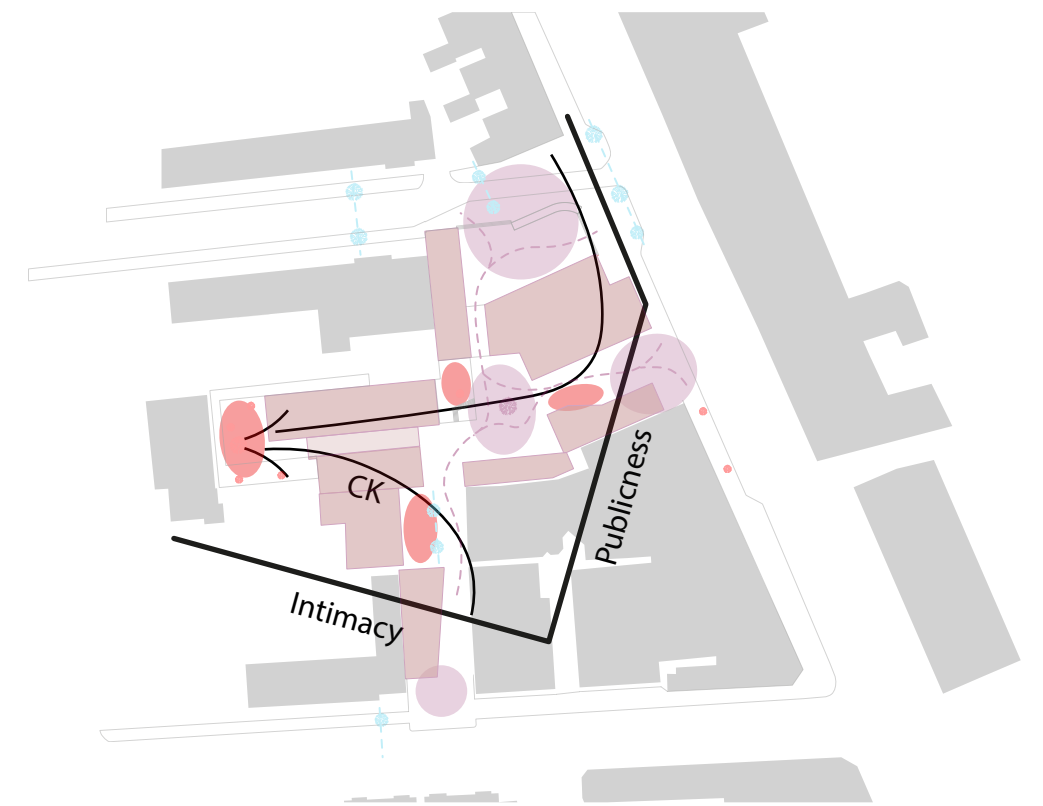



Complex edges

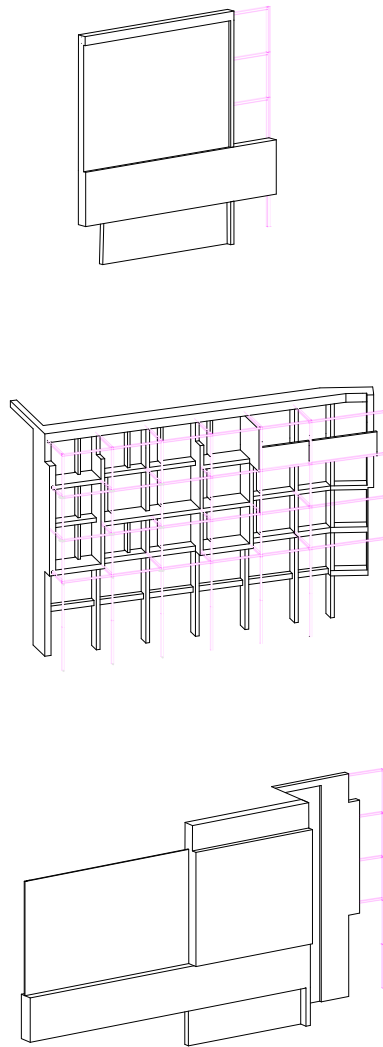

Opening up,
gradually intimate



Encloser,
quickly intimate,
vertical divider

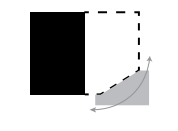



CK change of experience

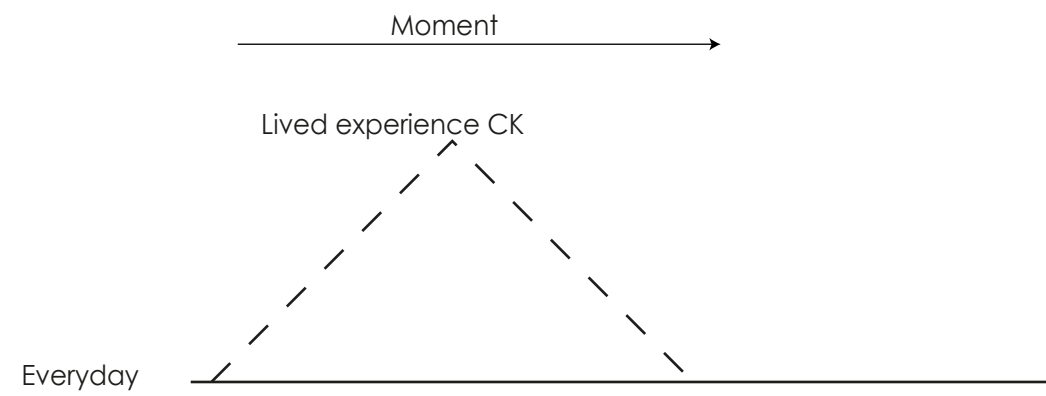

Person point of view

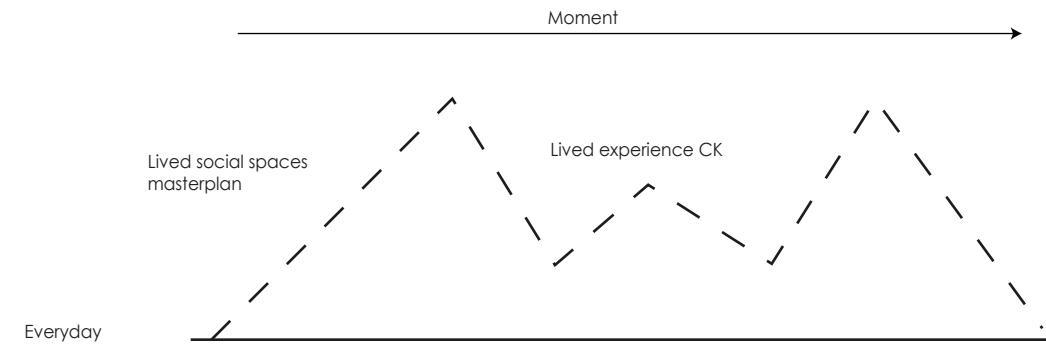

Lessing the backdrop

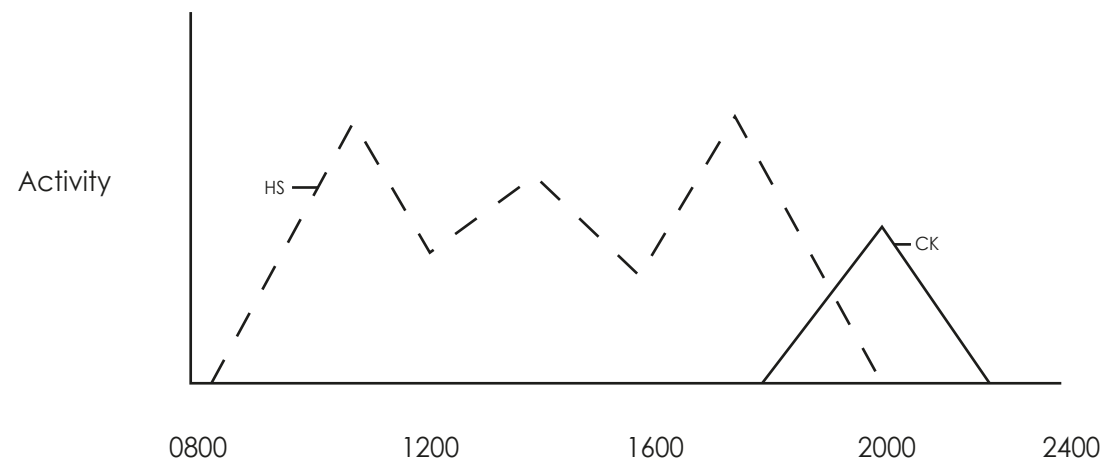

High street point of view

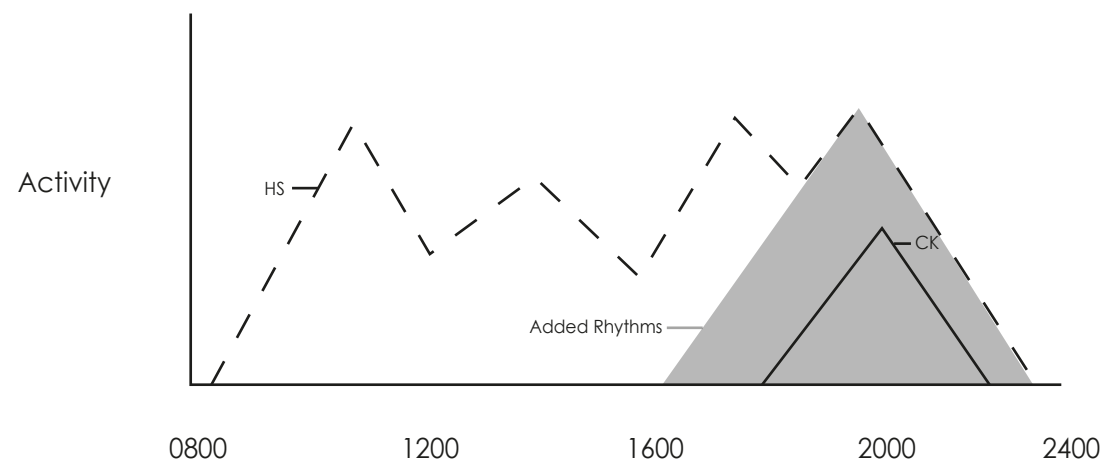

Vertical possibility

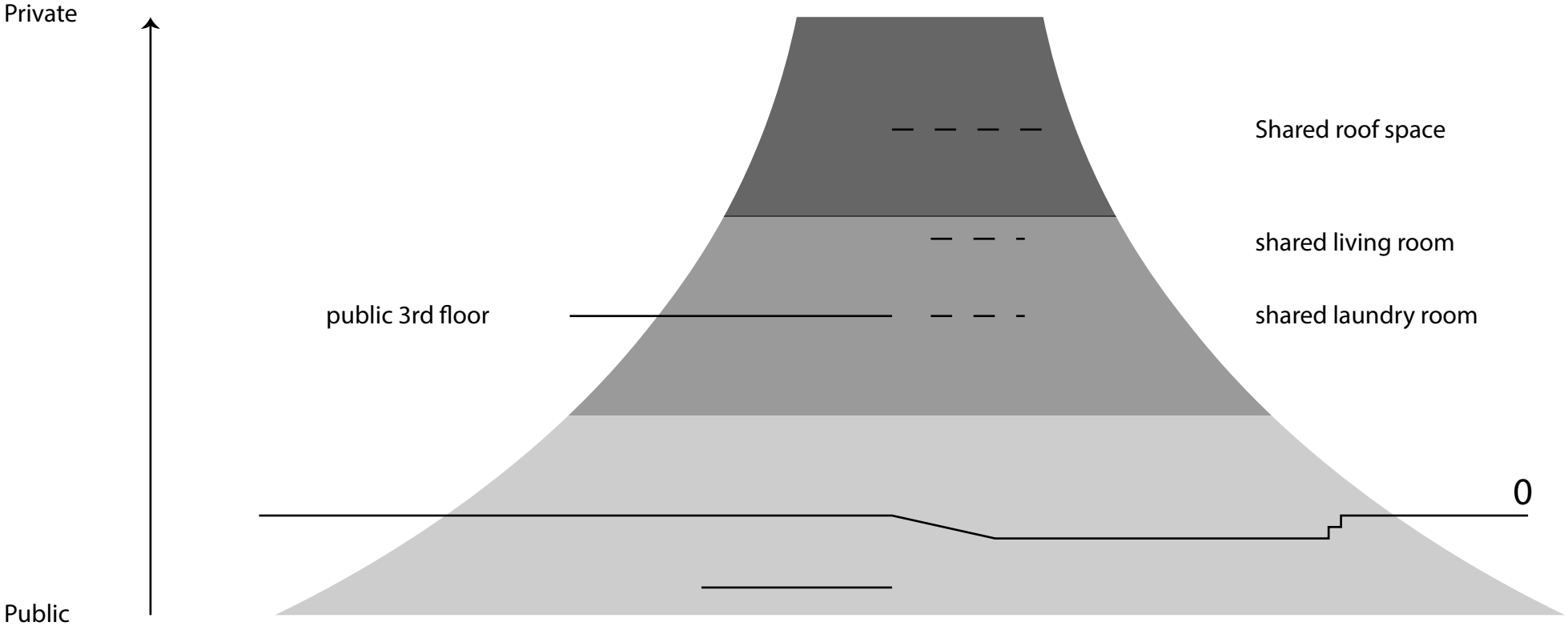

Common spaces on different lvl's

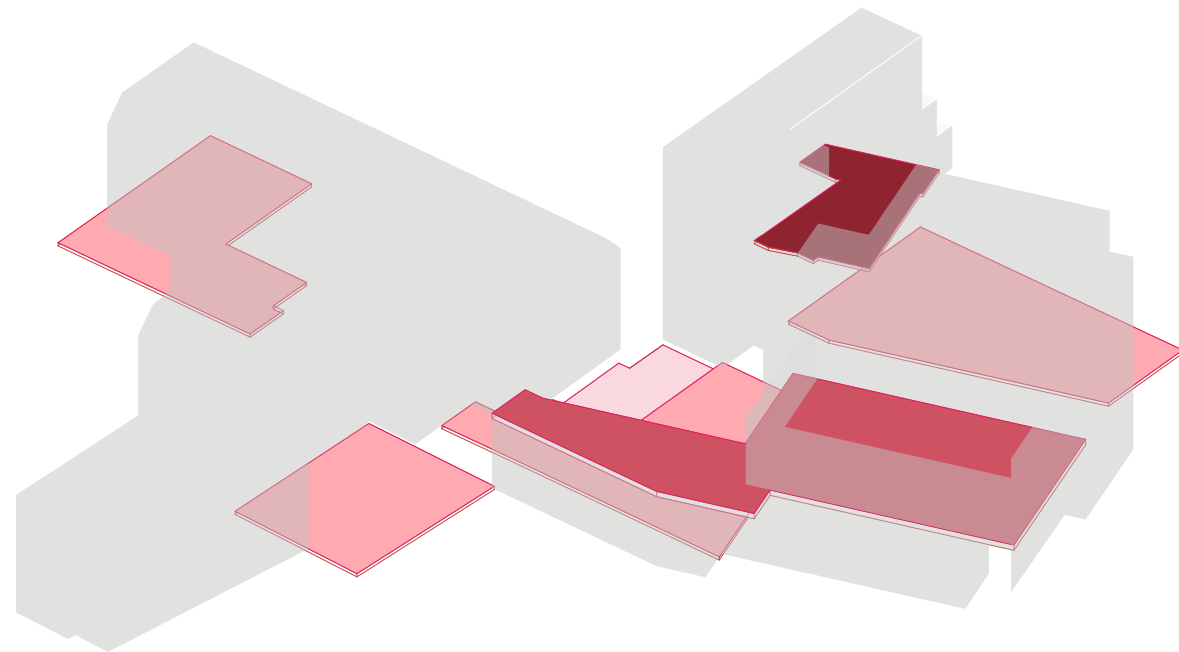

Construction articulates

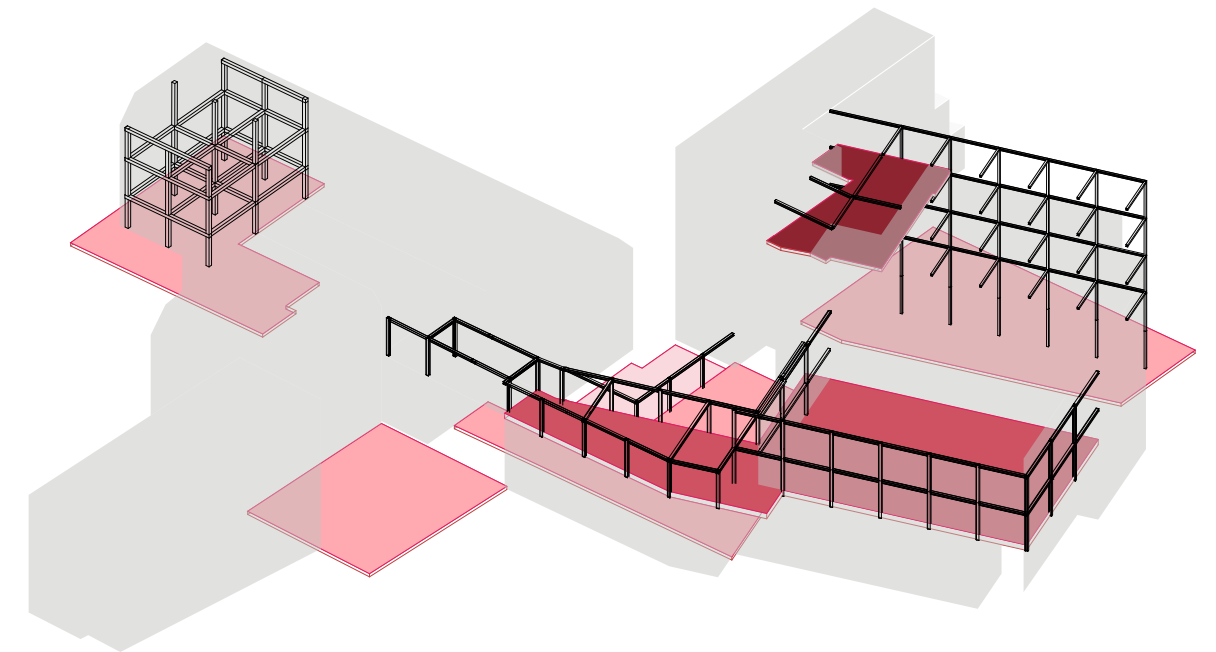



E0

C



Residential floors

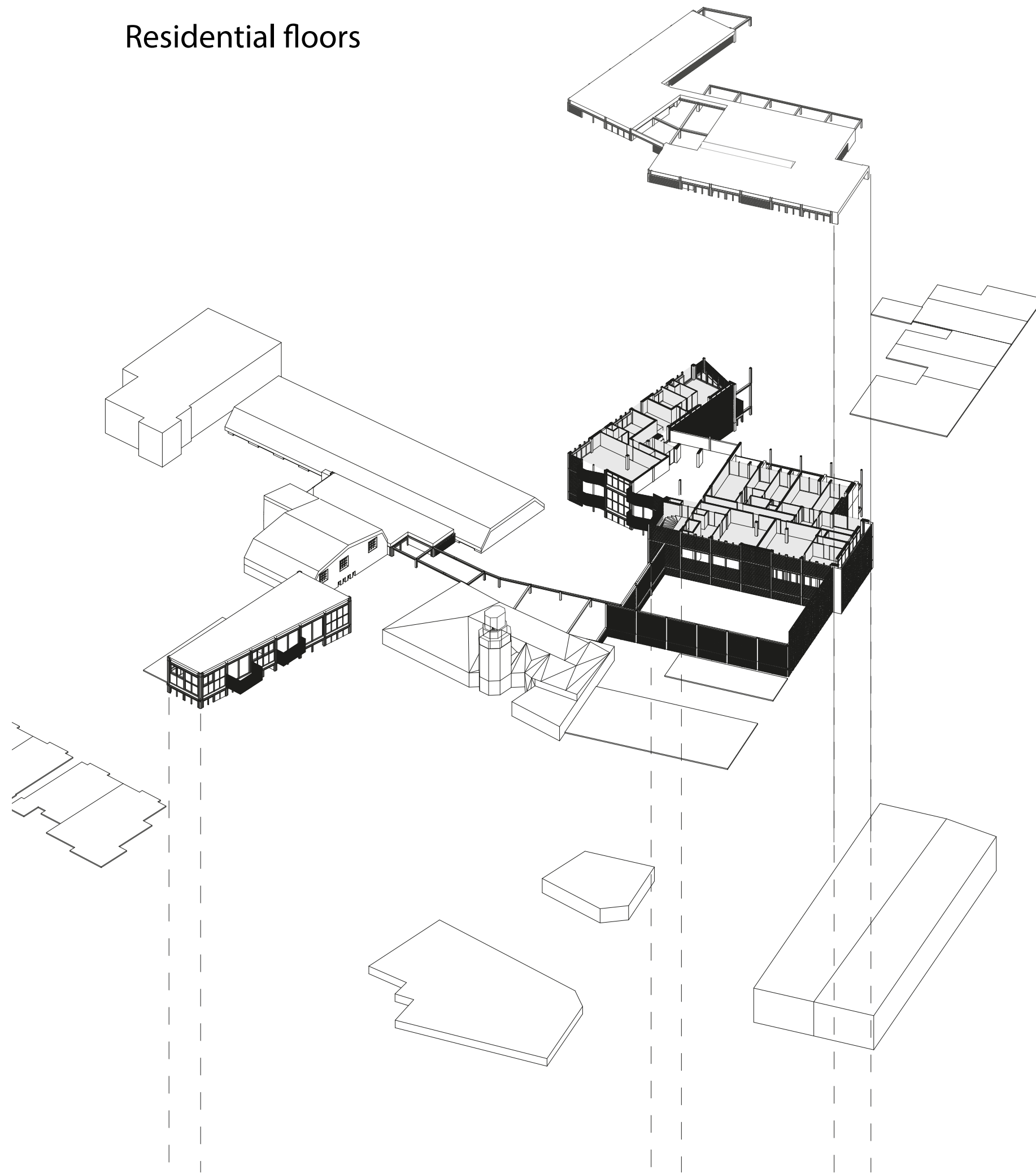

E4

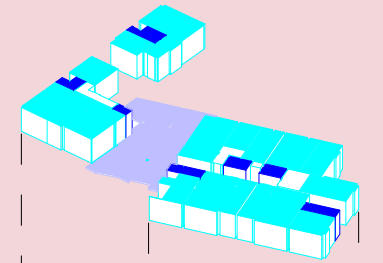

E5

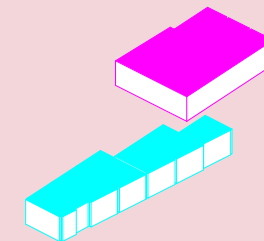
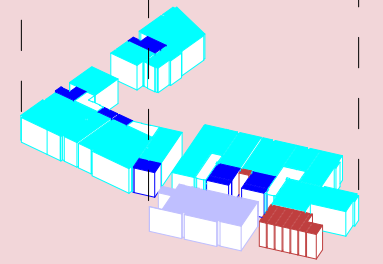

- Office space
- Storage
- Shared Laundry

- Housing
- Rest rooms

Transitional floors

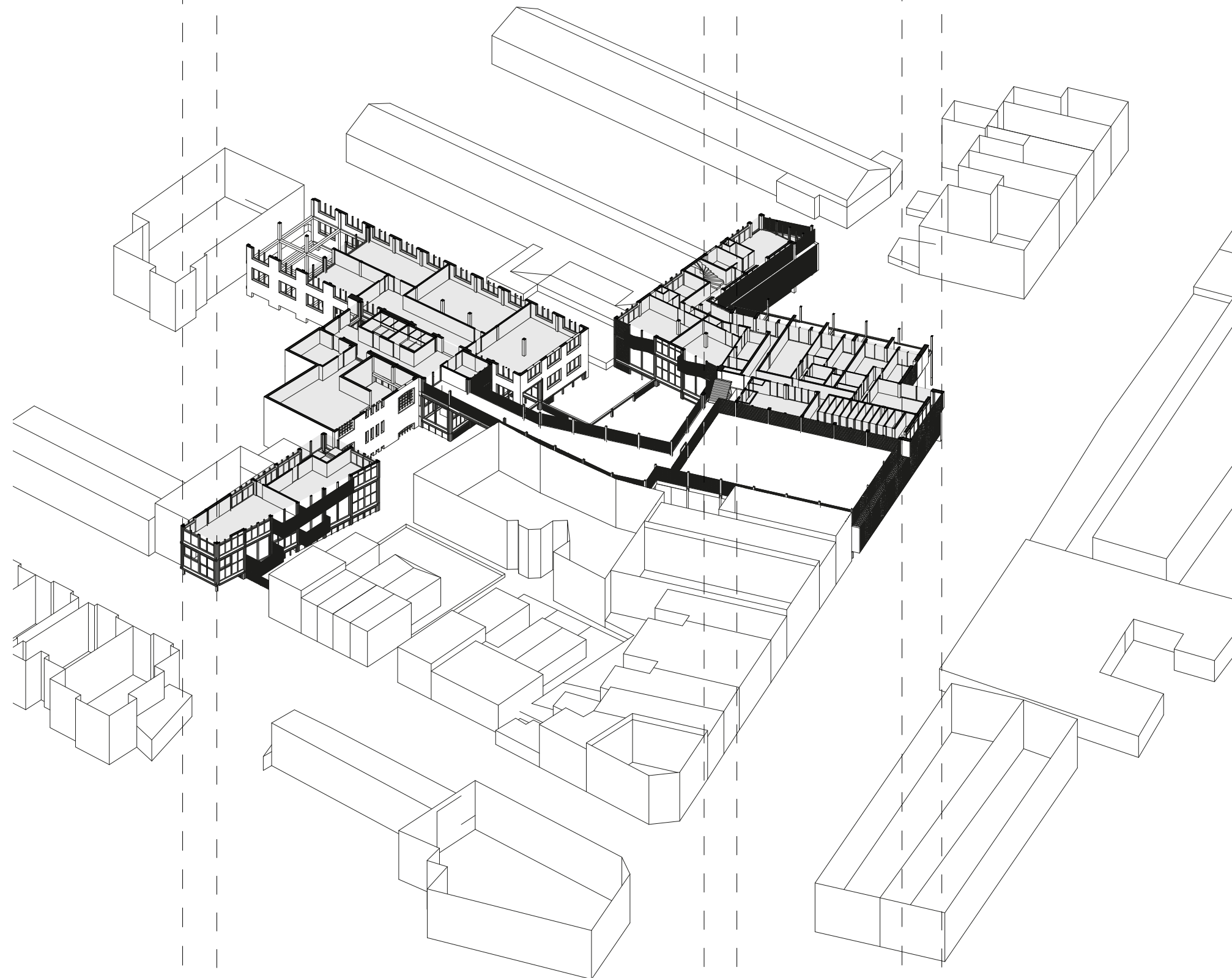



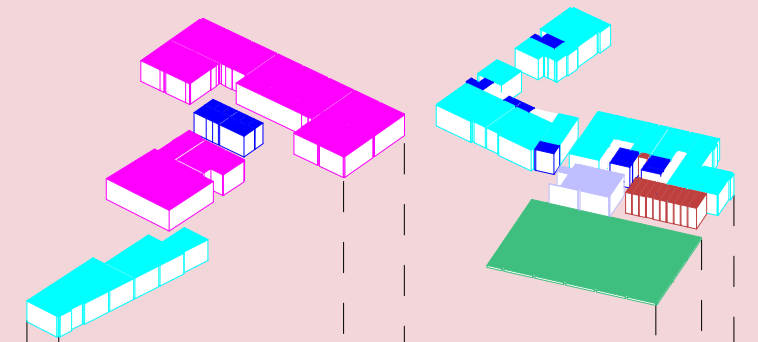



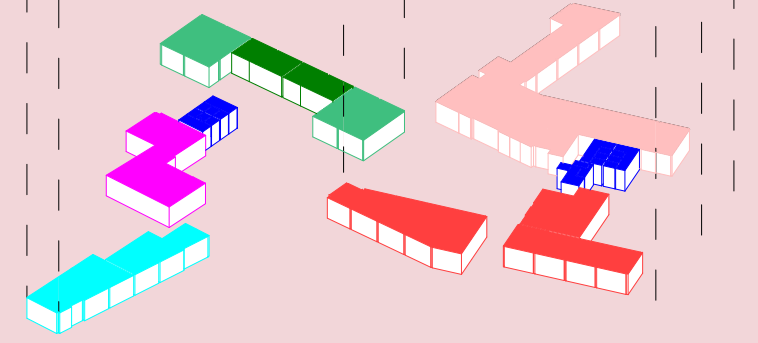

E2



E1



- | | |
|--|---|
|  Community Kitchen dining space |  Rest rooms |
|  Dance studio |  Kitchens and café's |
|  Library |  Shared Laundry |
|  Utility |  Storage |
|  Culture Centre common space | |

Ground floor

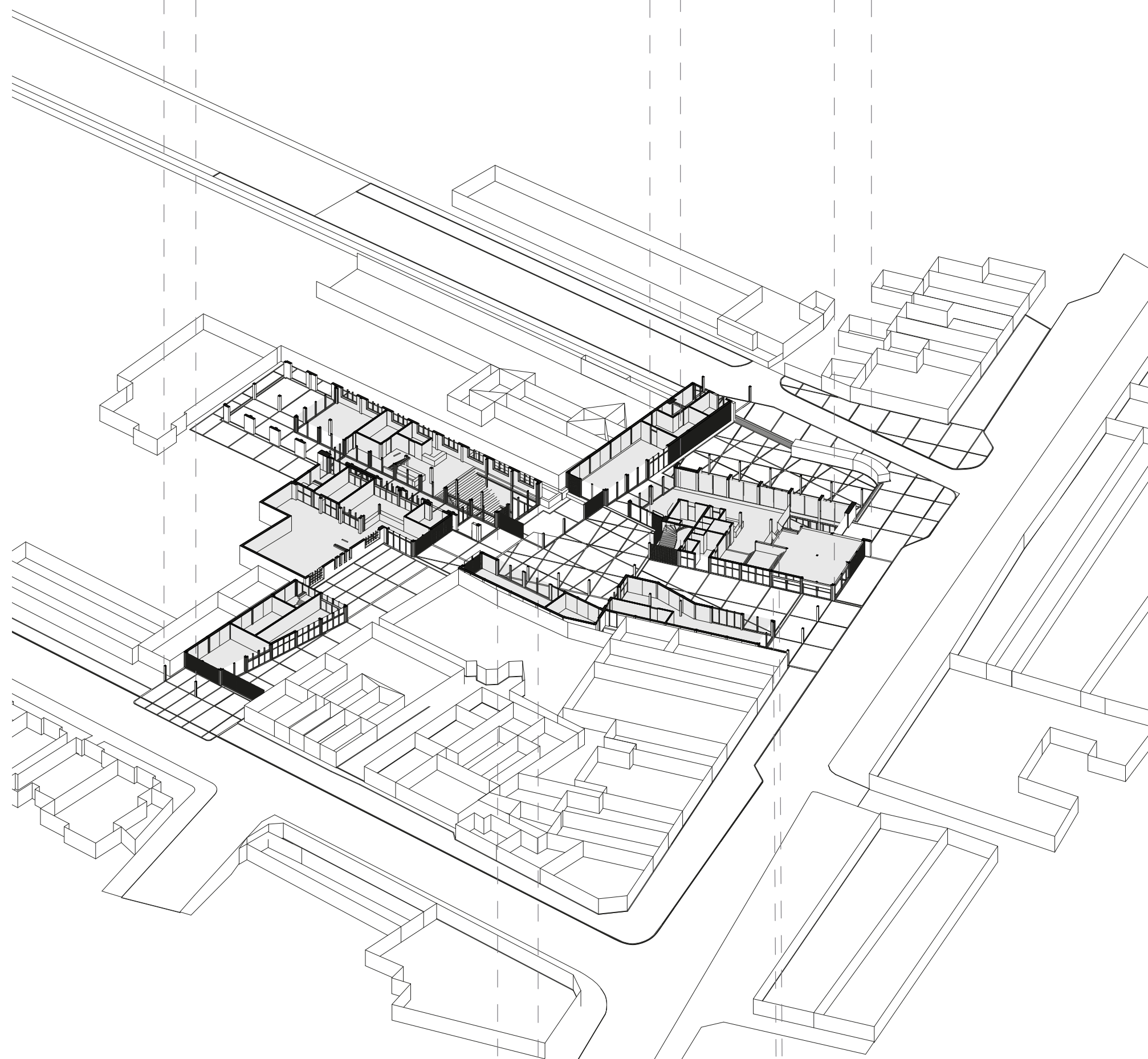

E0

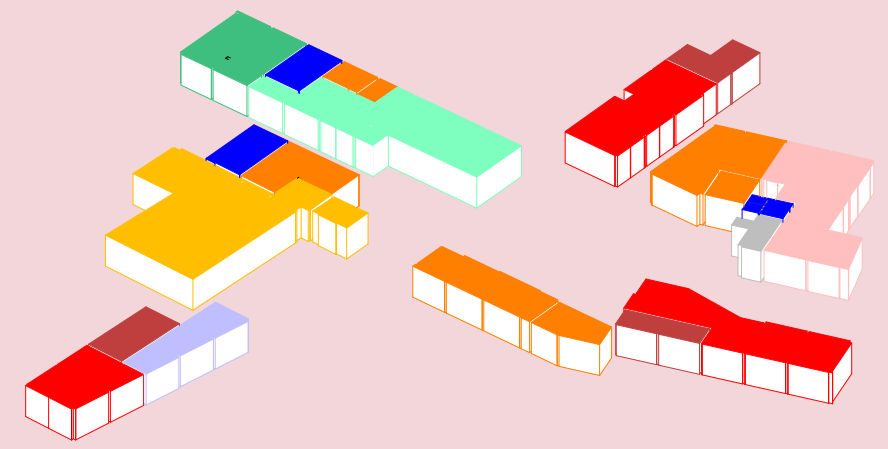

- Community Kitchen dining space
- Dance studio
- Library
- Utility
- Storage
- Culture Centre common space
- Rest rooms
- Kitchens and cafés
- Shared Laundry

Underground

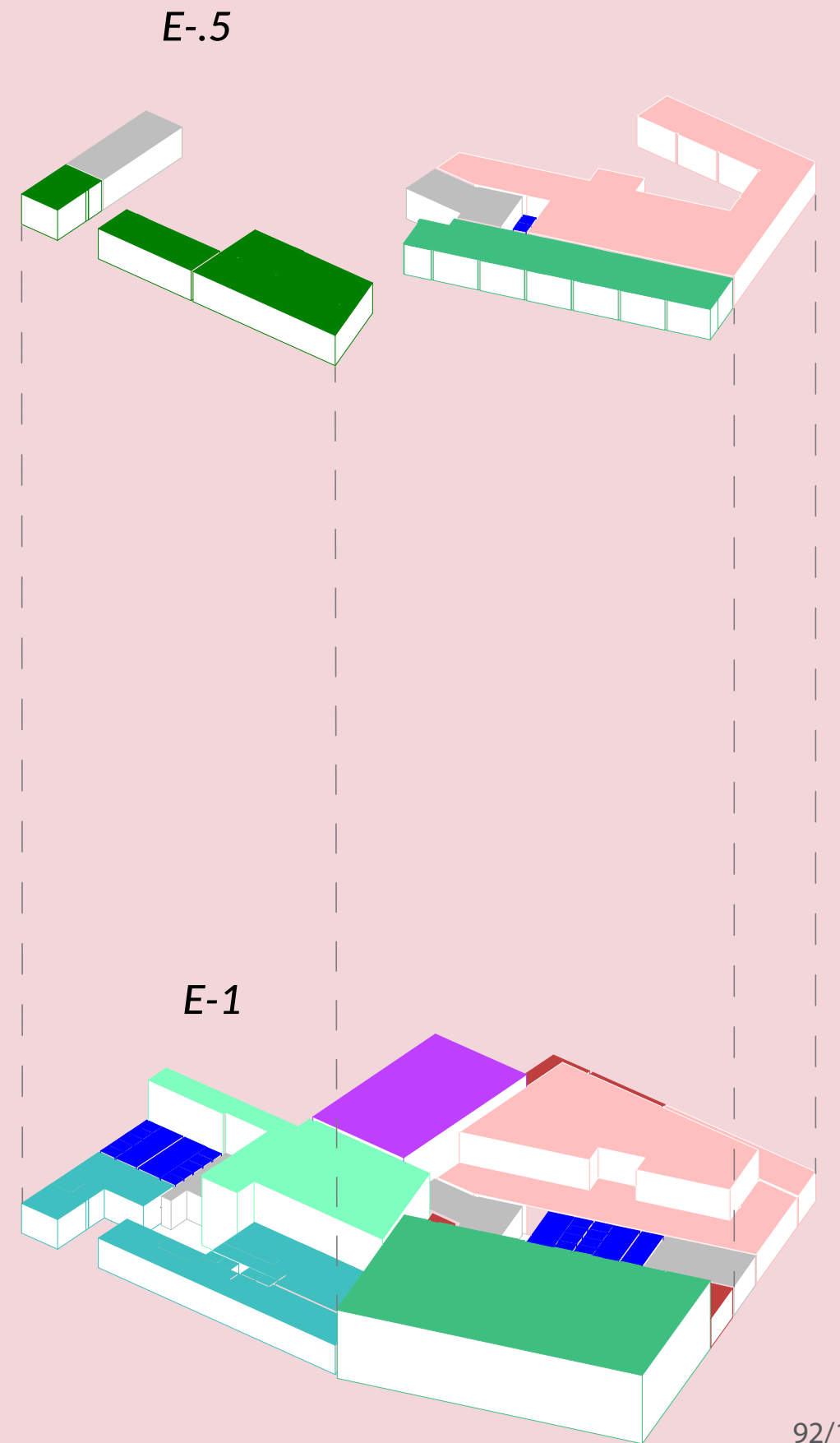
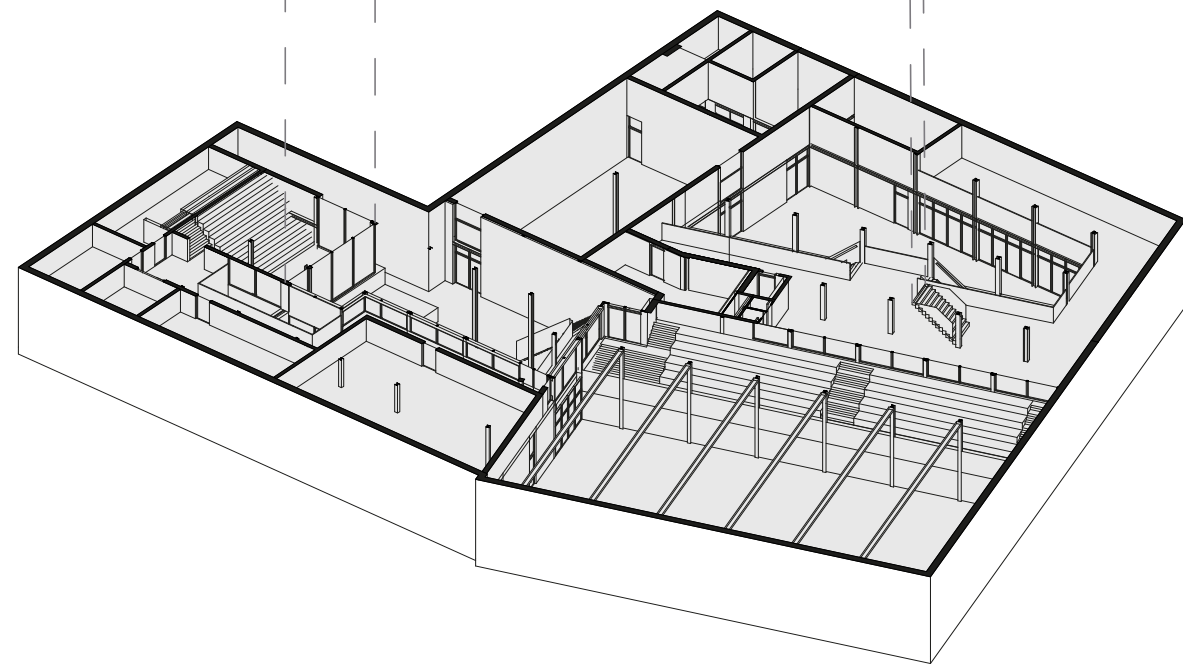

Section A



E-5





Interior intensity transition

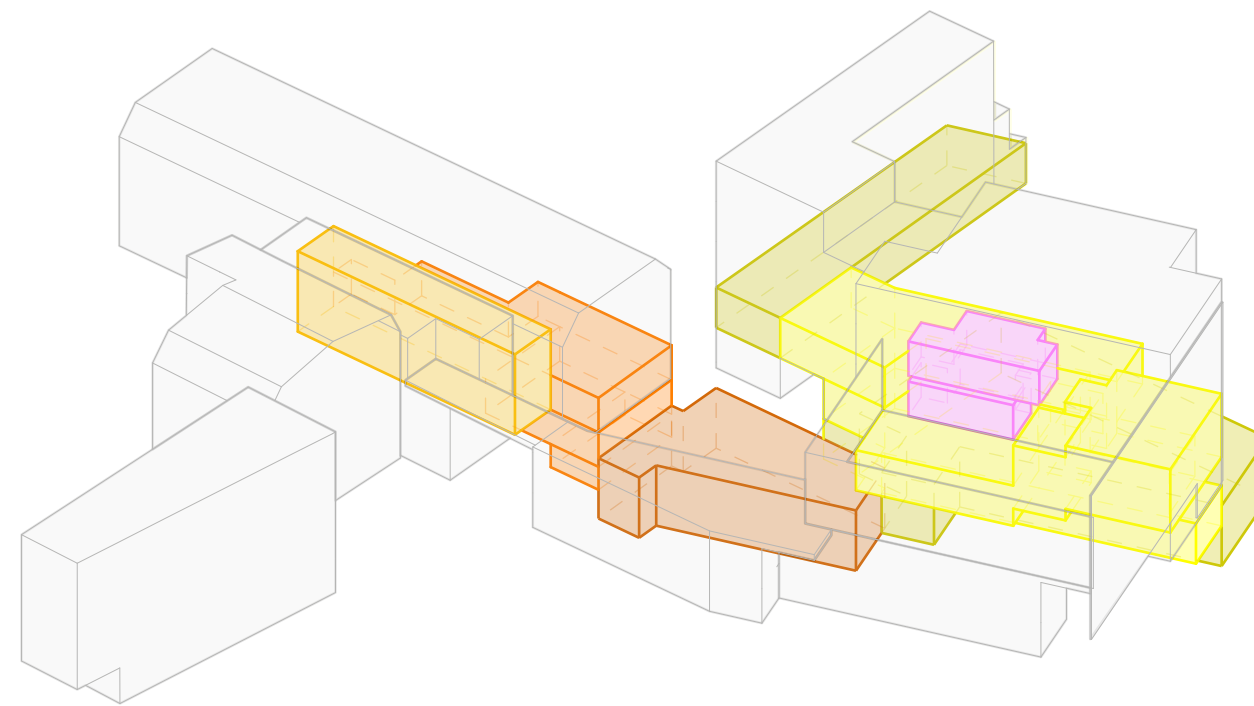

E3



Routes

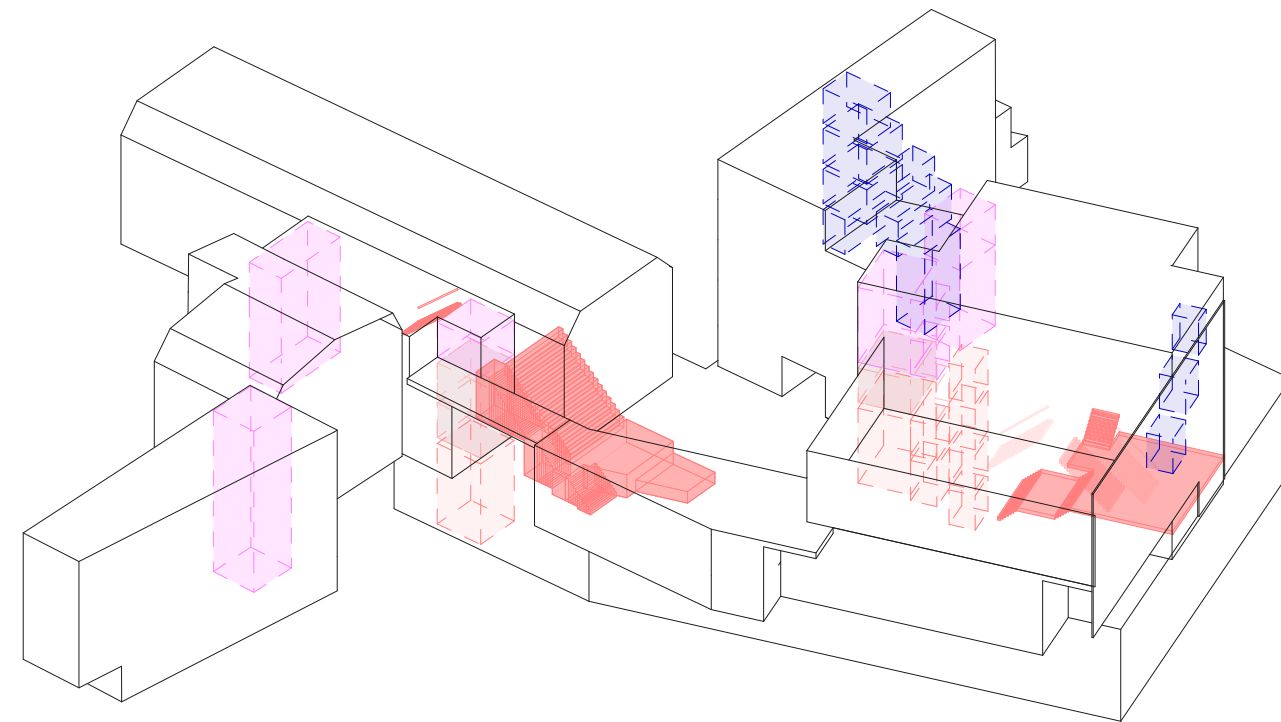







Types of thresholds

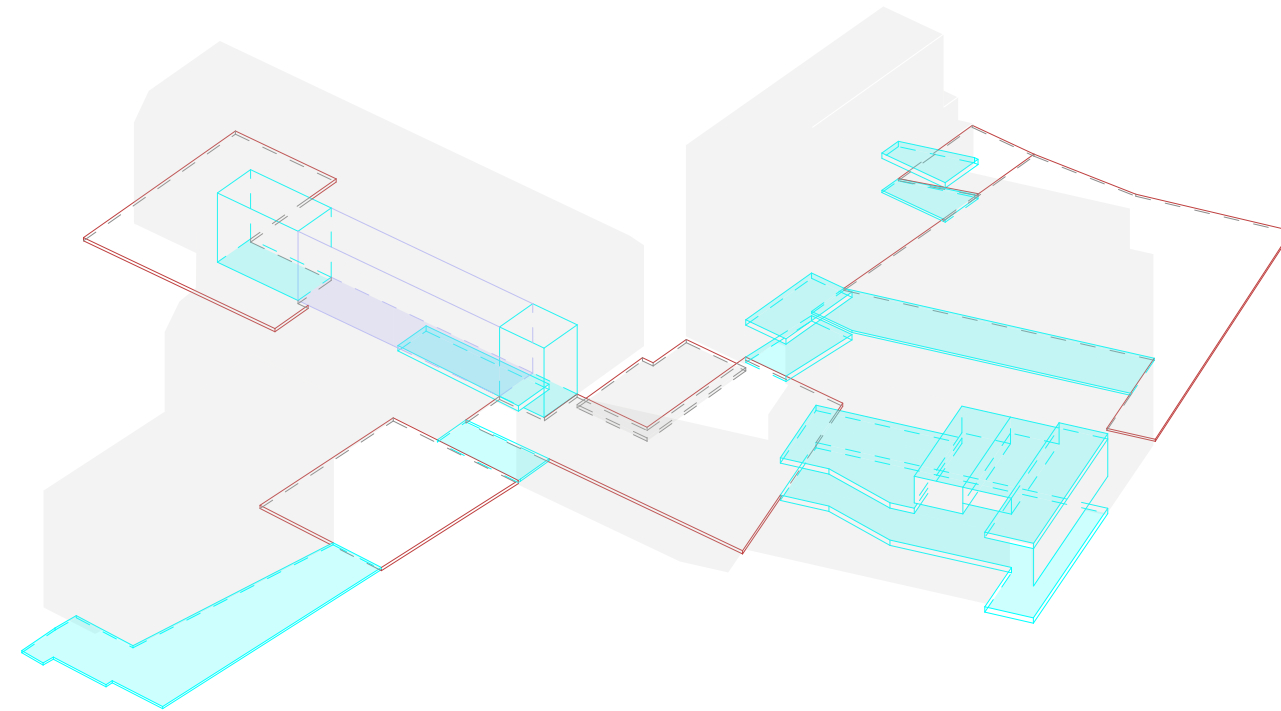

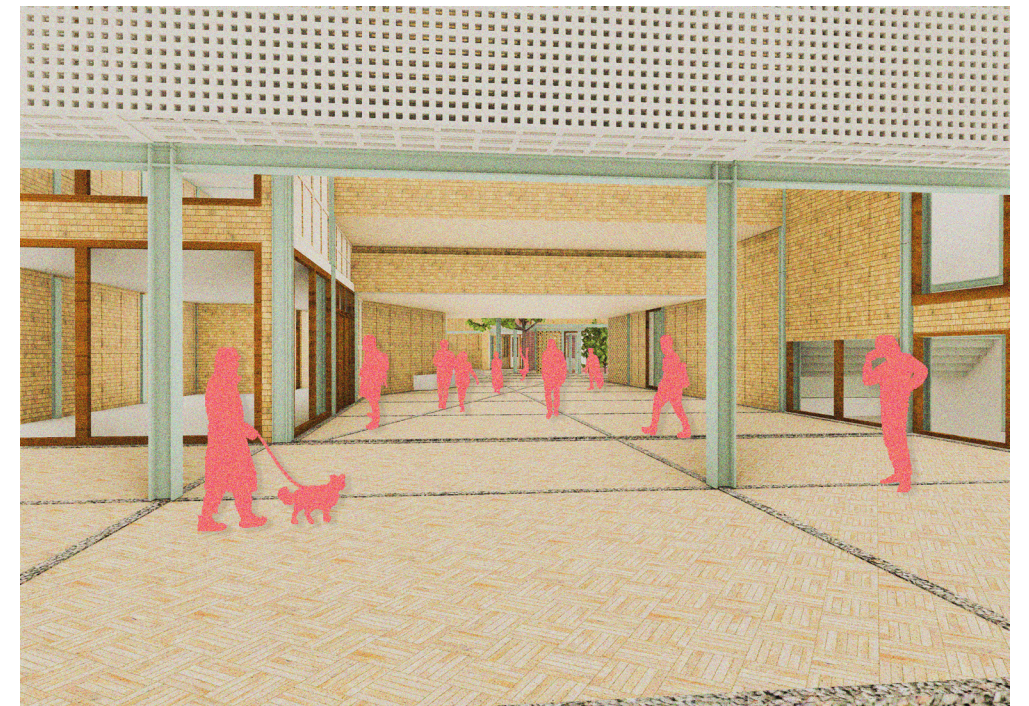
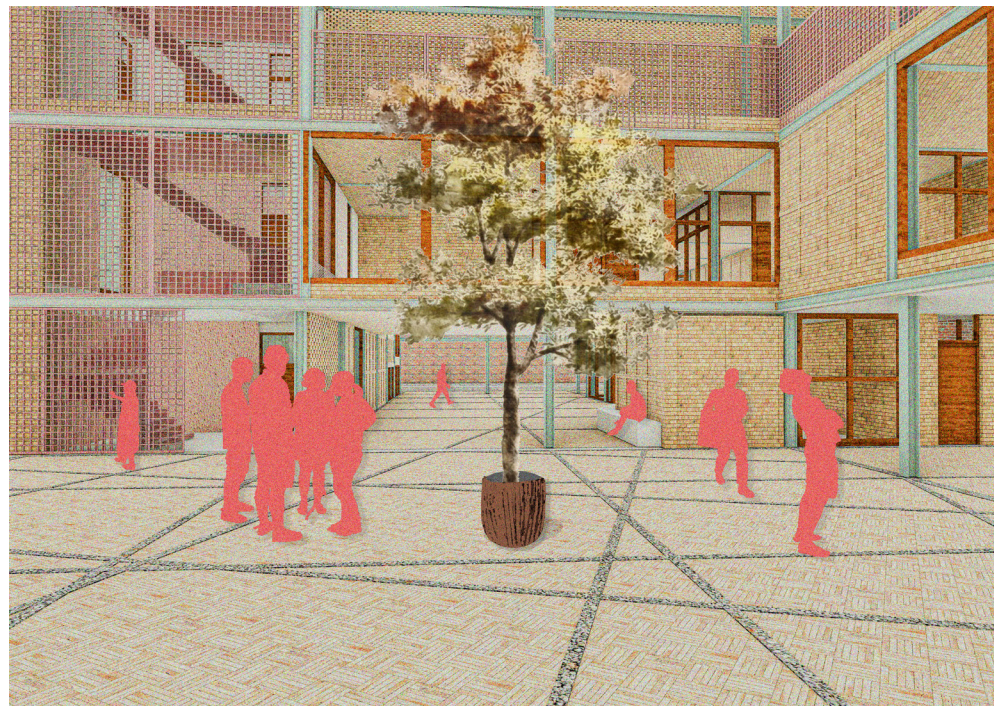

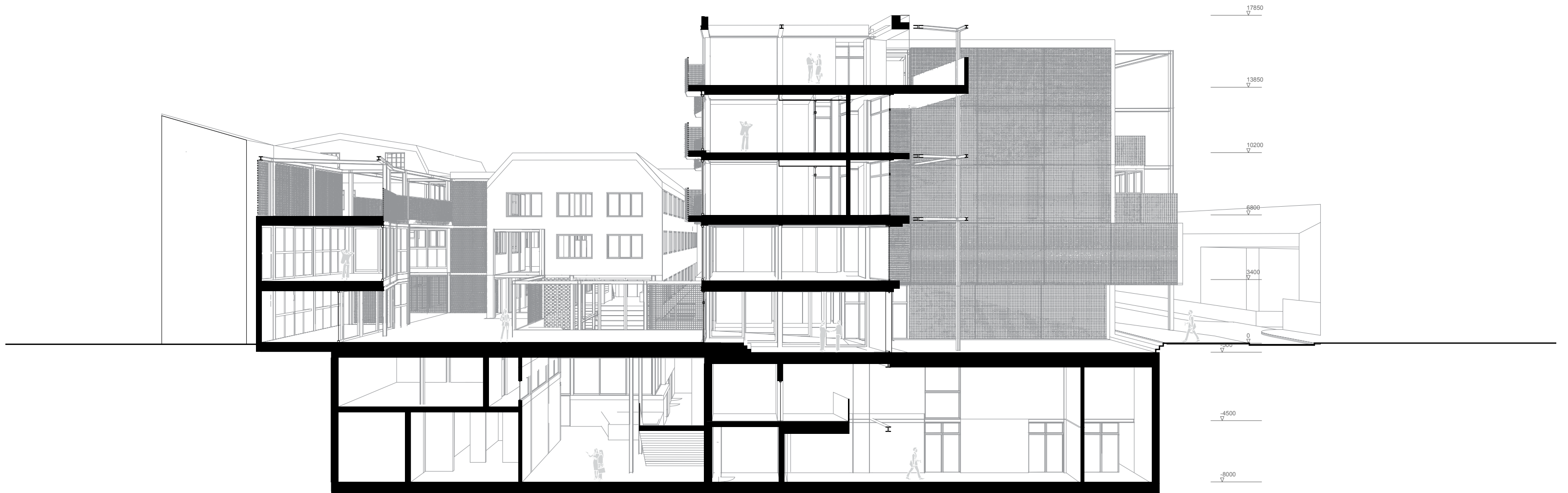



Food and the threshold

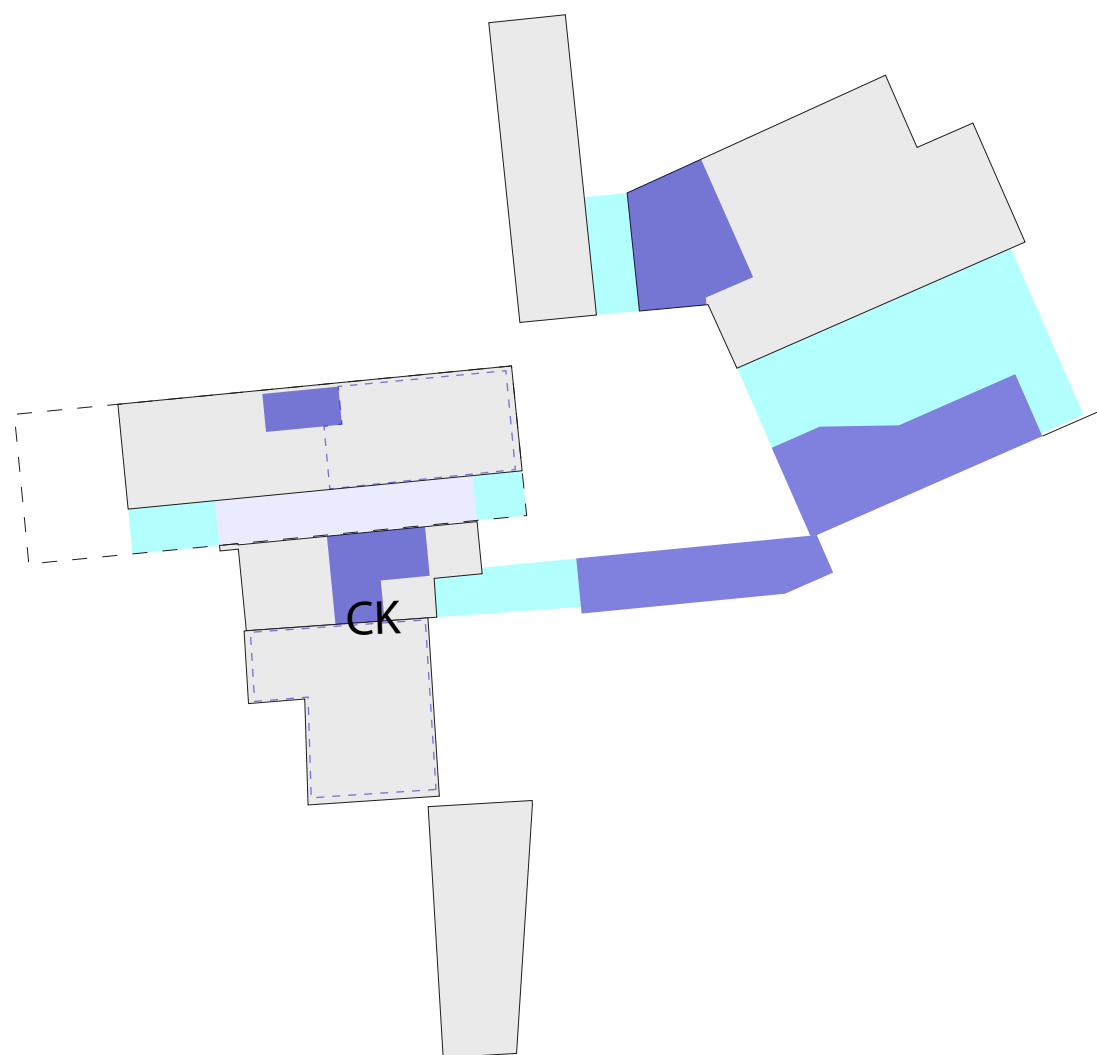



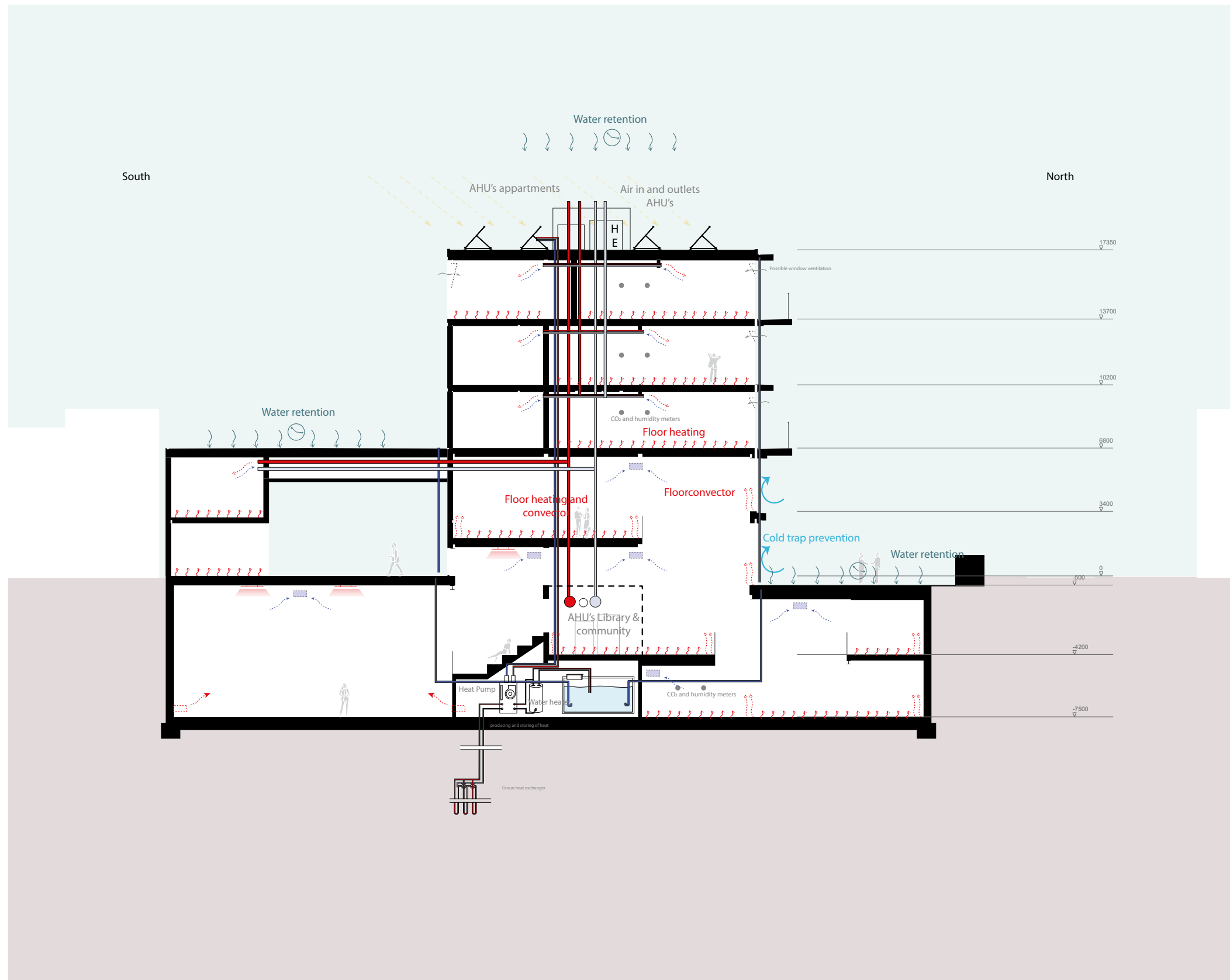

Detail 1

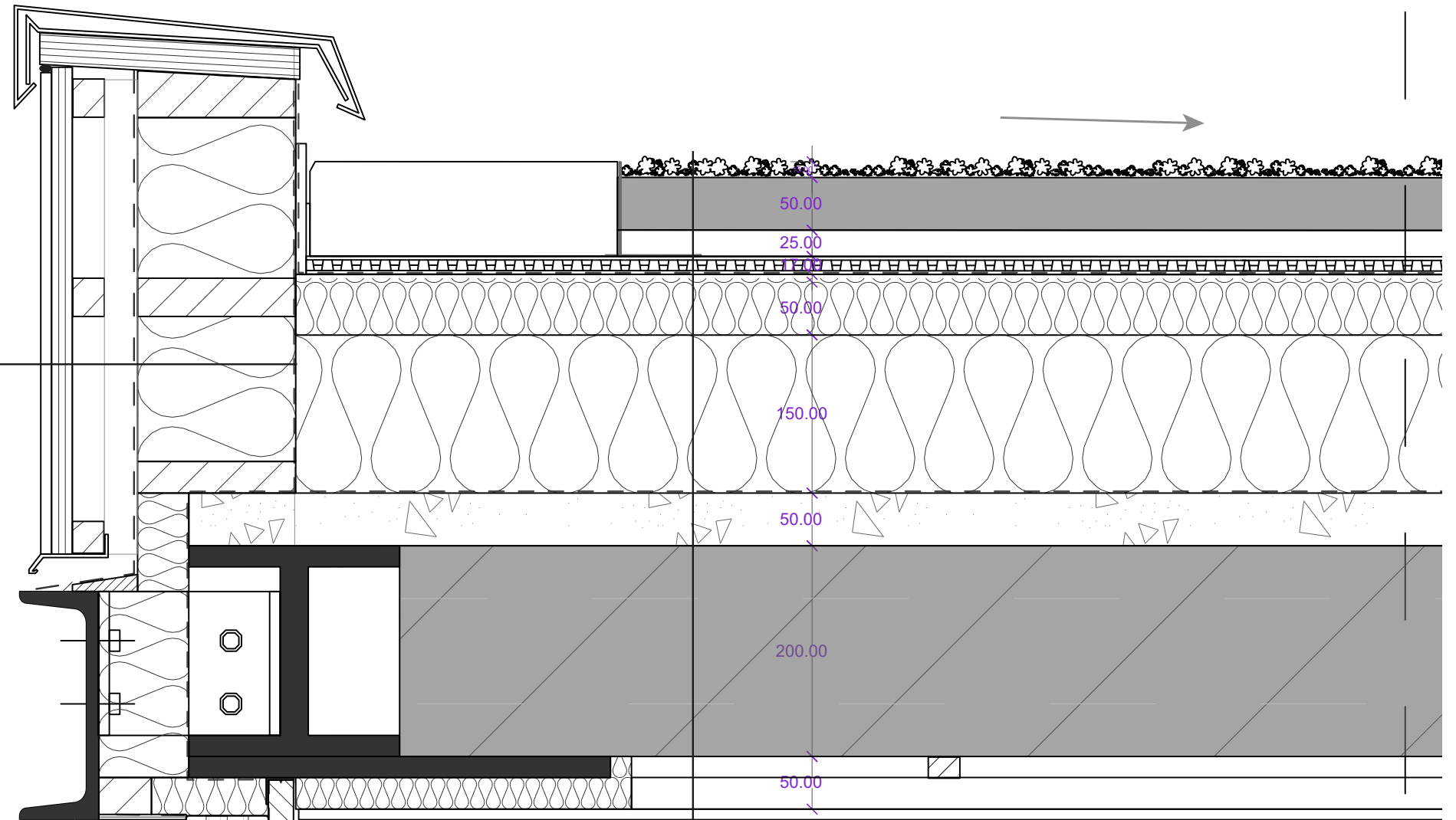

- Vapor barrier
- insulated OSB element
- Water repellent EPDM foil
- cavity
- wooden studs
- multiplex
- waterrepellent plaster

- Nophadrain Vegetation mat - sedum
- ND DGS-E substrate
- ND WSM-25 water reservoir
- hard insulation
- insulation
- pressure layer
- hollow-core concrete flooring
- wooden ceiling studs
- ceiling panels

Detail 2

- Neuffer wooden tilt and slide doors
- vapor barrier
- thermal insulation
- aluminium drainage profile
- cavity
- brick facade element with fall prevention safeguard

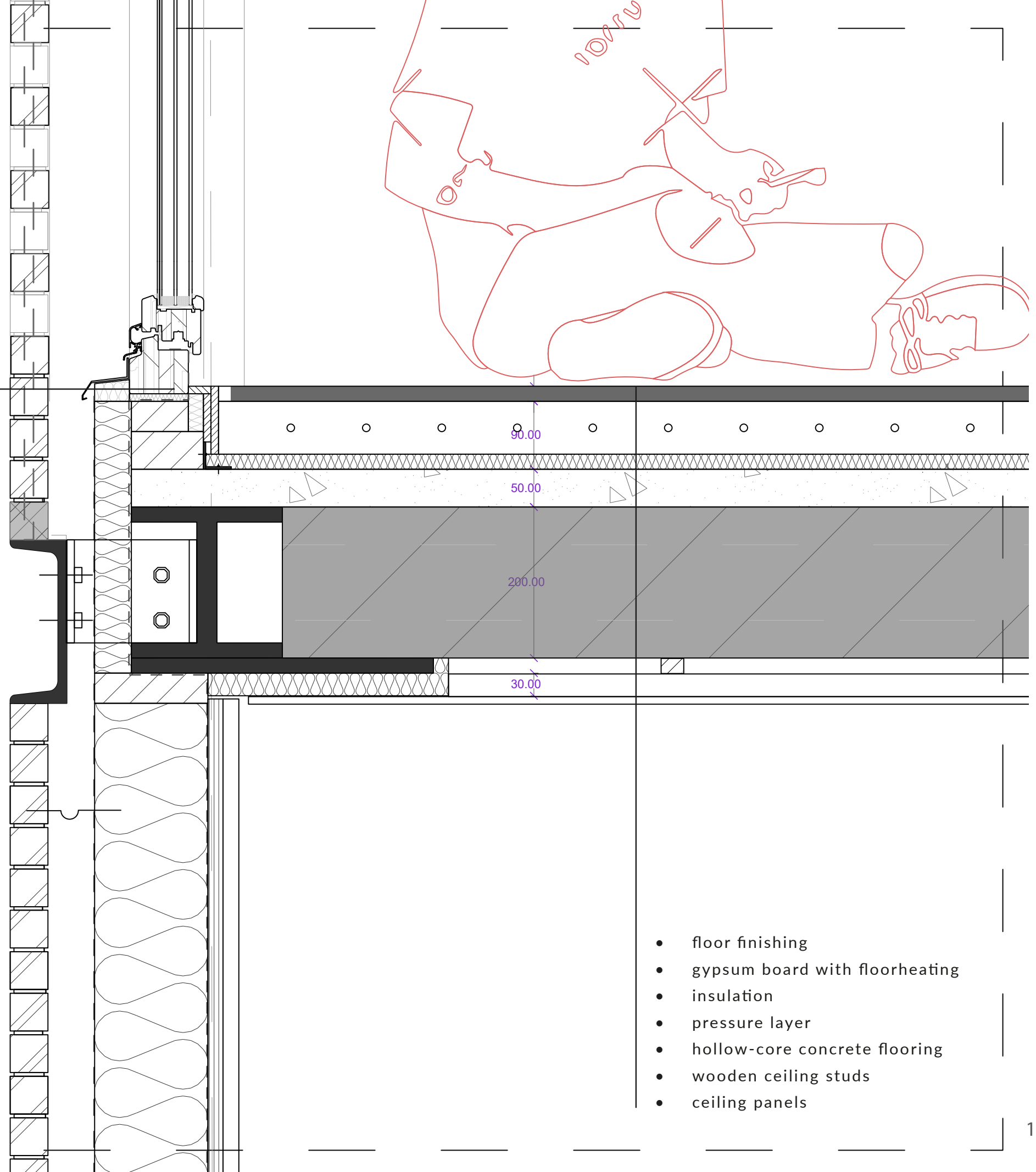

- floor finishing
- gypsum board with floorheating
- insulation
- pressure layer
- hollow-core concrete flooring
- wooden ceiling studs
- ceiling panels

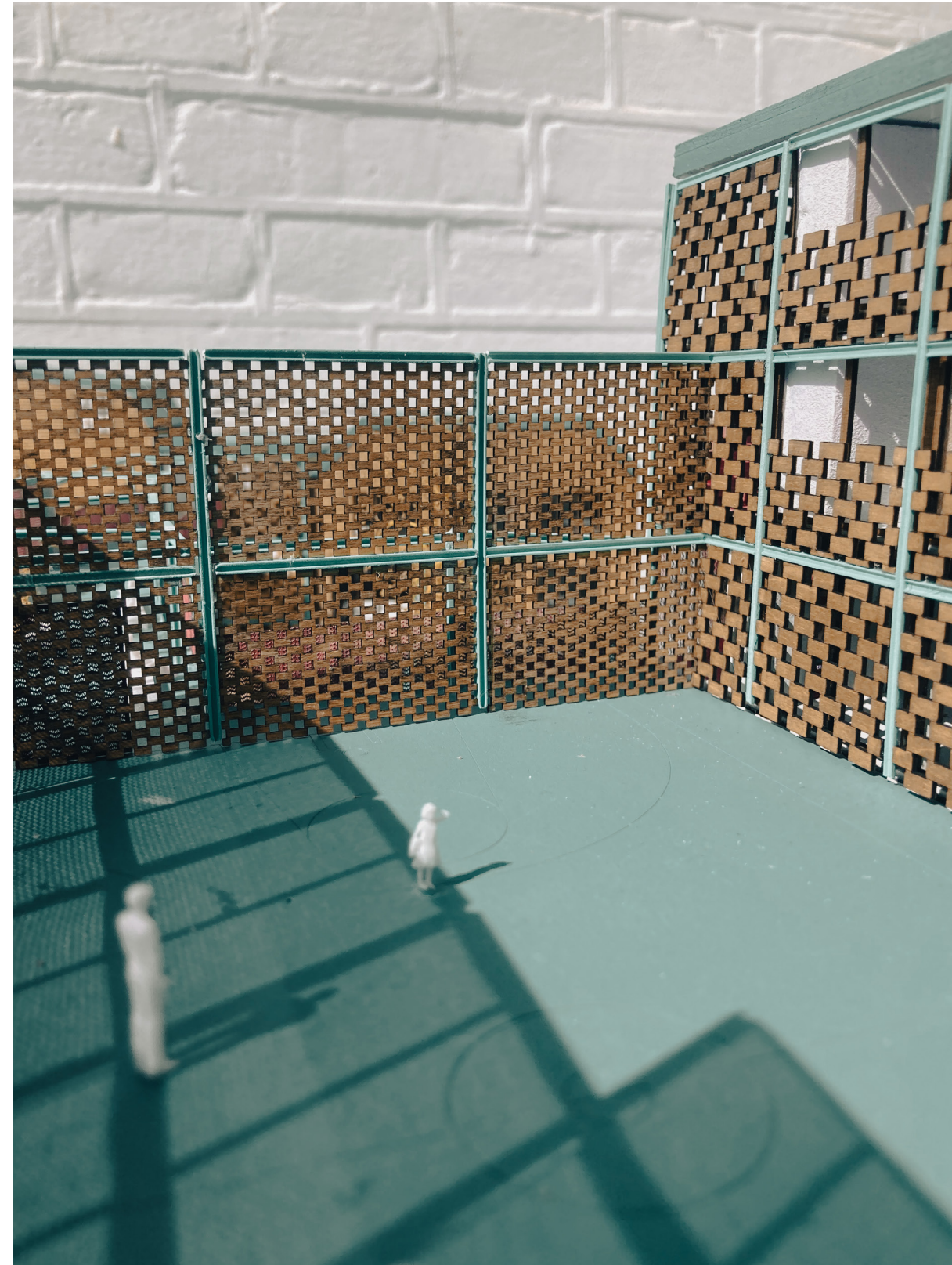

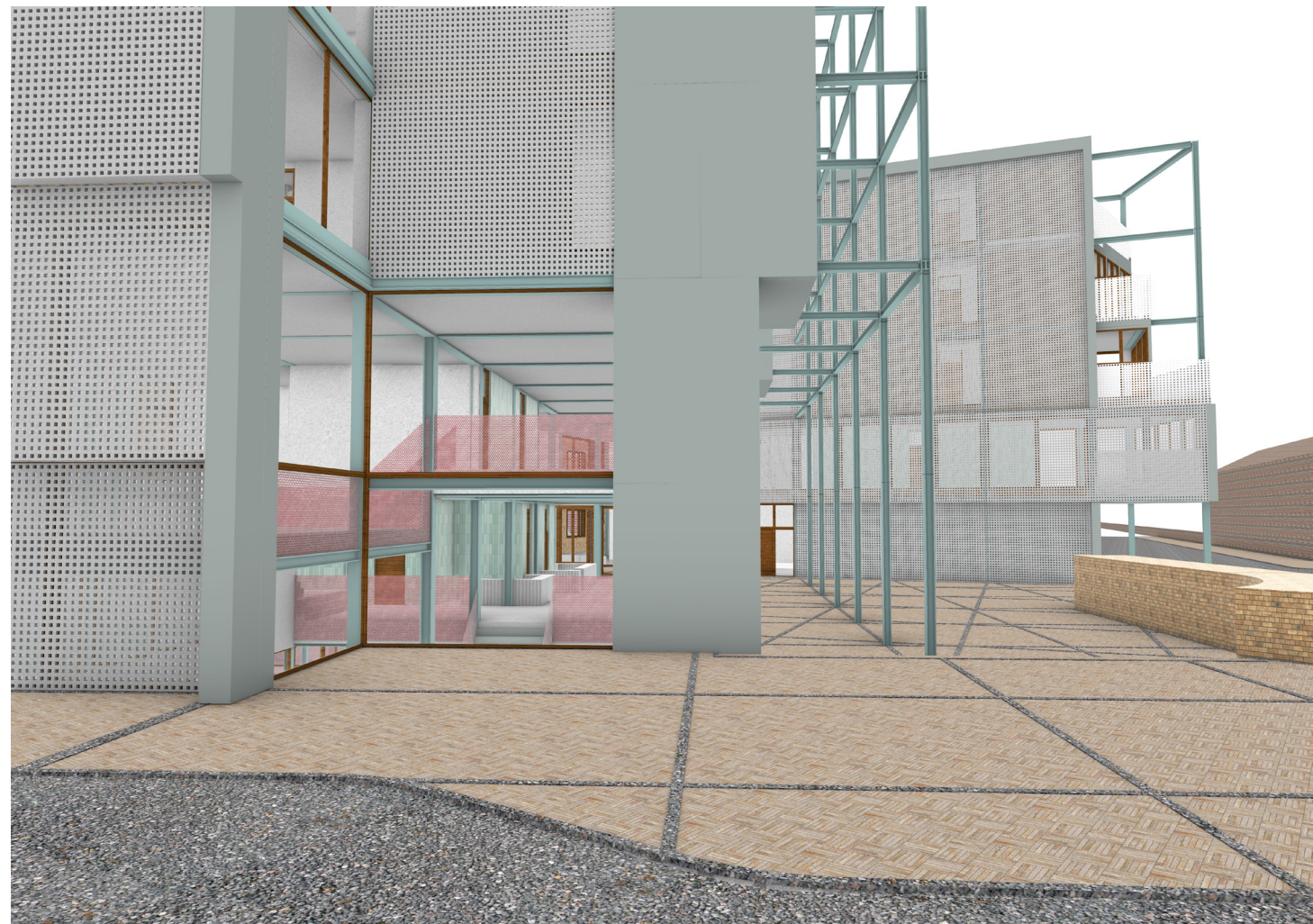

Detail 3

- vegetation free zone, concrete tiling
- drainage
- water repellent epdm foil
- wooden eaves system with metal top element
- multiplex
- water repellent plaster

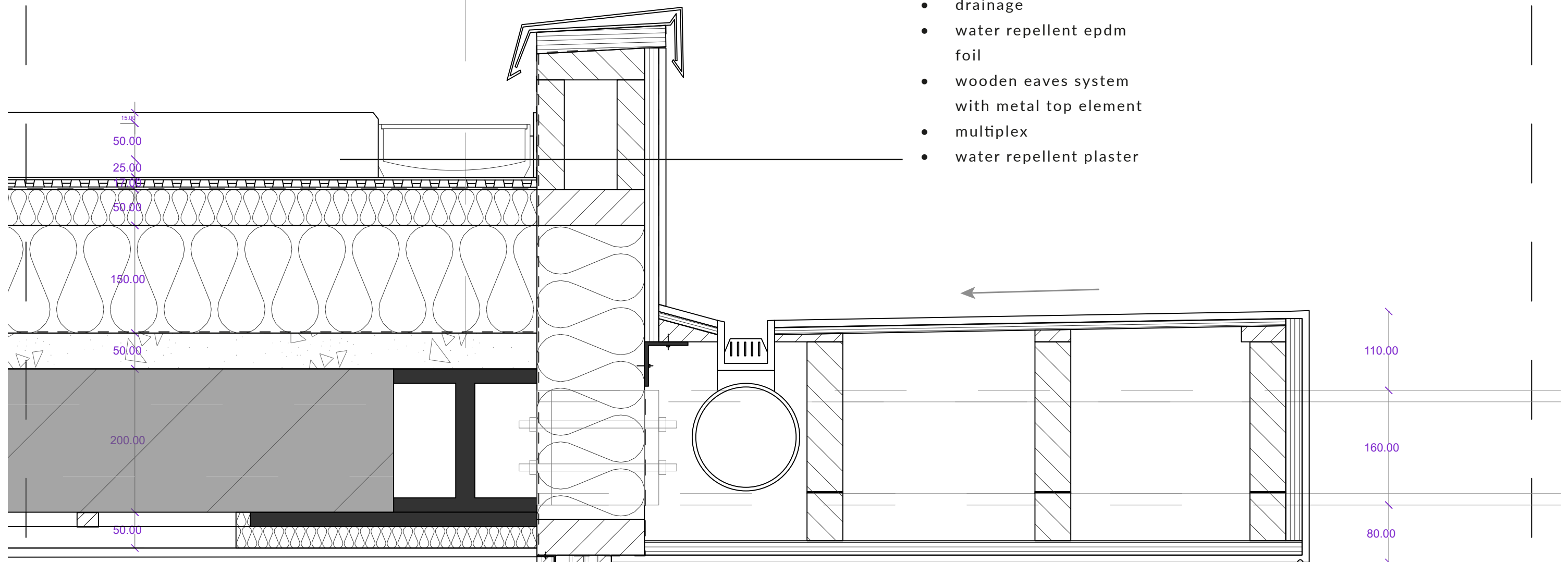

Detail 4

1:5

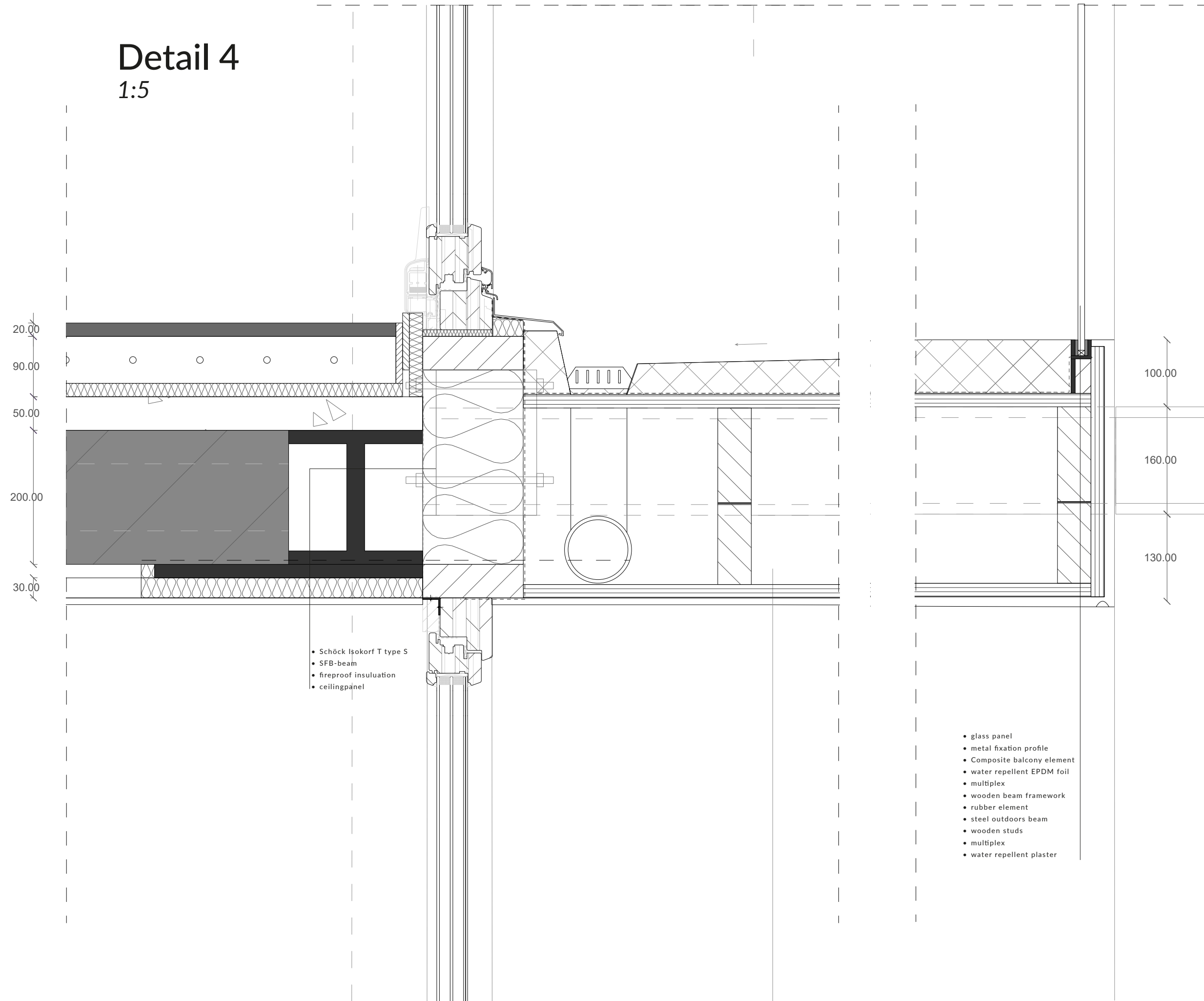

- Schöck Isokorf T type S
- SFB-beam
- fireproof insulation
- ceilingpanel

- glass panel
- metal fixation profile
- Composite balcony element
- water repellent EPDM foil
- multiplex
- wooden beam framework
- rubber element
- steel outdoors beam
- wooden studs
- multiplex
- water repellent plaster

Detail 5

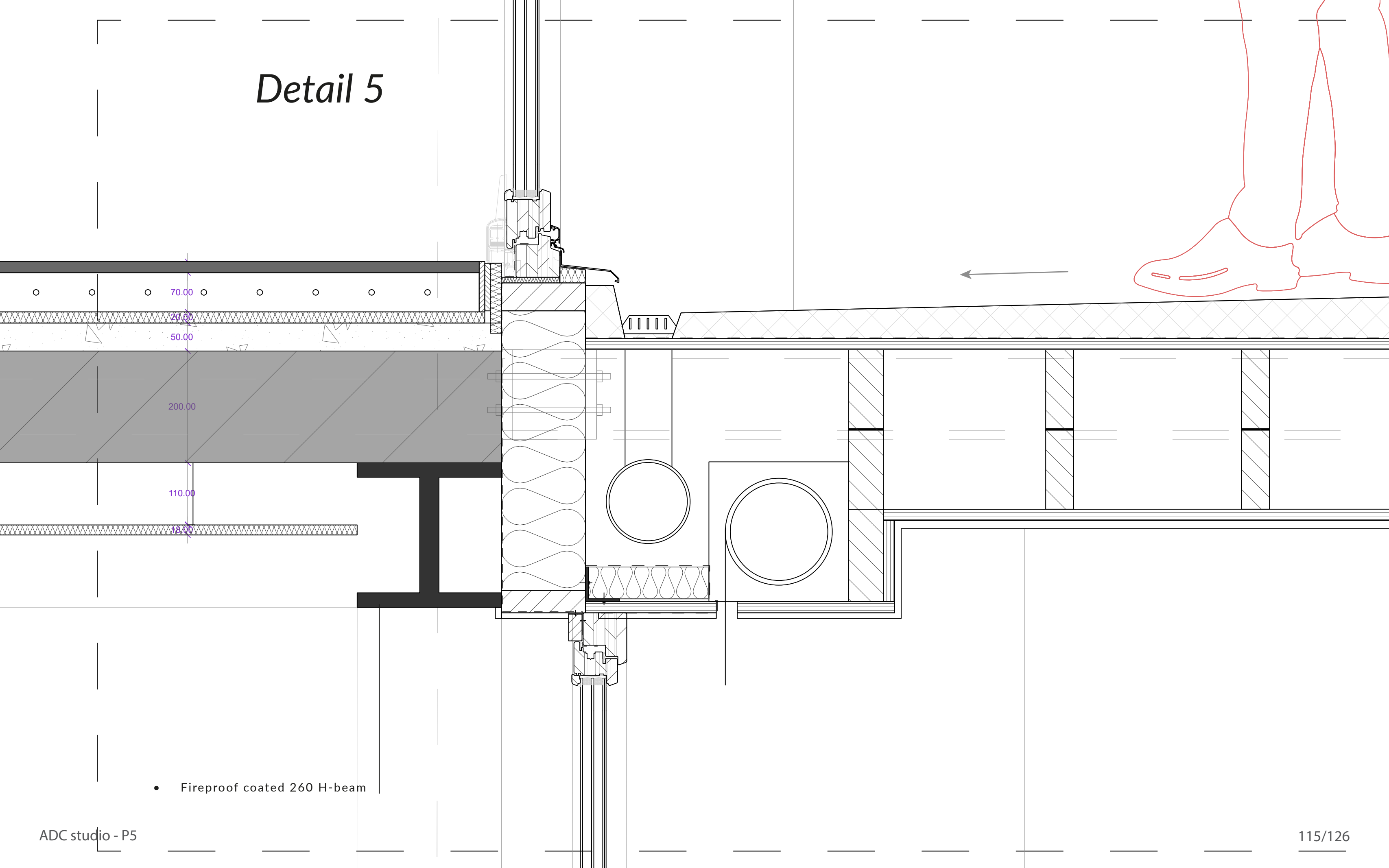

- Fireproof coated 260 H-beam

Detail 6

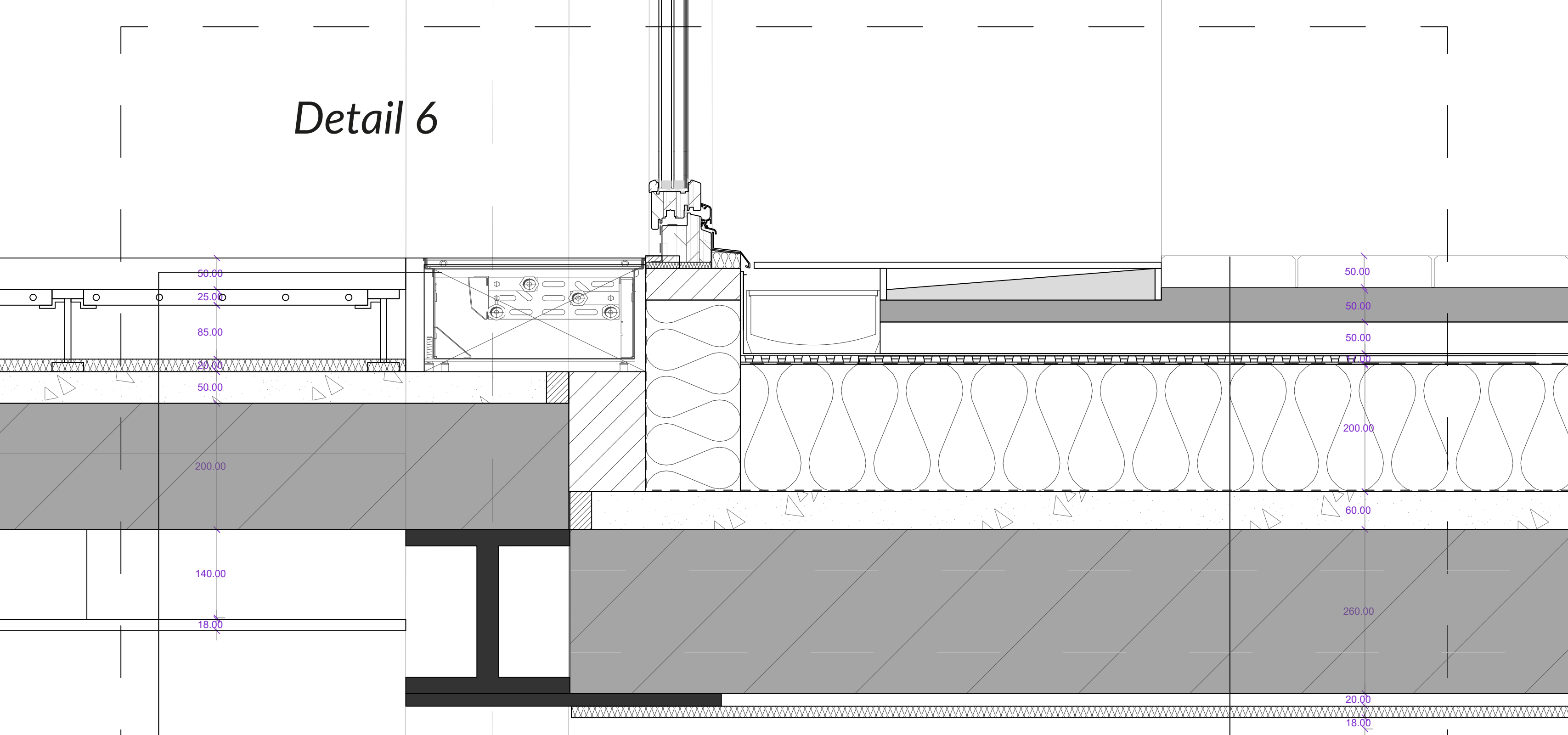

- Katherm ID induction ventilation unit
- raised floor heating system
- insulation
- pressure layer
- hollow-core concrete flooring
- Topakustik Perfo T acoustic panels

- brick pavement
- sand substrate
- ND WSM-50 water reservoir
- ND 220 drainagesystem
- hard insulation
- insulation
- pressure layer
- hollow-core concrete flooring
- Topakustik Perfo T acoustic panels

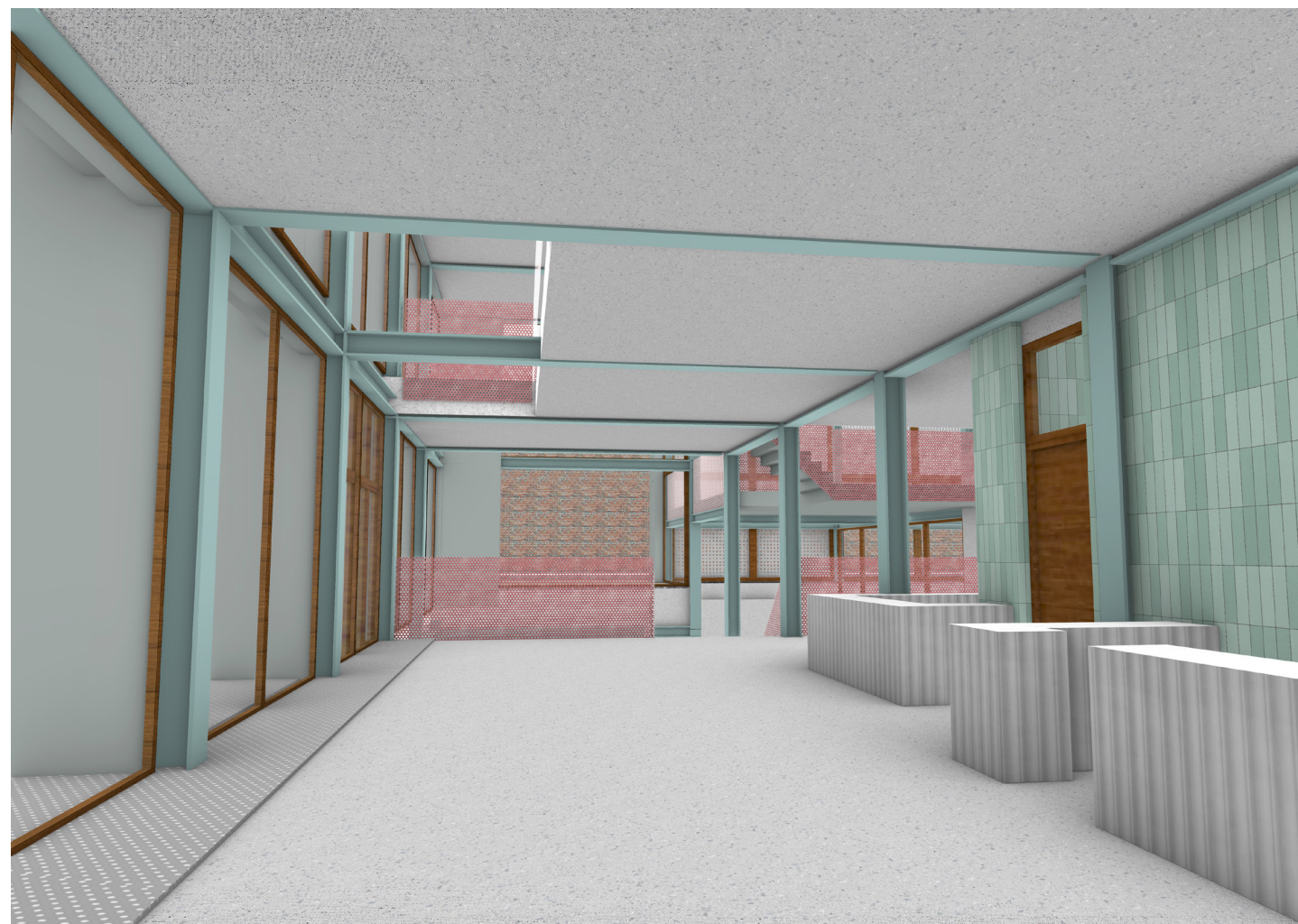



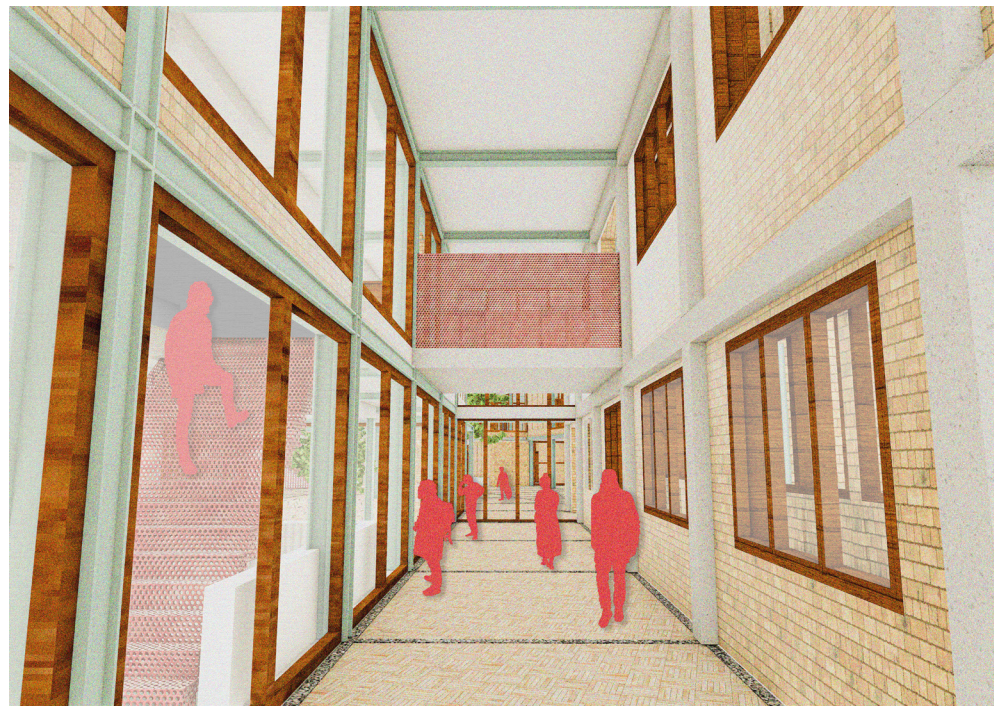











Thank you!

