

STRUCTURALISM EXCURSION GUIDE



MSC 3 Graduation studio:
Heritage and Architecture







1. Blaakse bos (Cube houses) (1978)

Architect: Piet Blom

Location: Overlaak 70, Rotterdam

Group members: Joris Hartmans, Jelle Hettema, Lydia de Vries



2. Raadhuis Ter Aar (1970)

Architect: Joop van Stigt

Location: Aardamseweg 4, Ter Aar

Group members: Marjan Sadeghi



3. Amsterdam Burgerweeshuis (1960)

Architect: Aldo van Eyck

Location: IJsbaanpad 3, Amsterdam

Group members: Jelmer Dankers, Valery Eshuis, Jonathan Verhoef



4. 't Karregat (1973)

Architect: Frank van Klingeren

Location: Urkhovenseweg 16, Eindhoven

Group members: Michelle Bettman, Anne Ebbenhorst, Morsal Habib



5. Muziekcentrum Vredenburg (1978)

Architect: Herman Hertzberger

Location: Utrecht

Group members: Jeroen Bogaard, Jeroen Moerman, Josephine Uitenbogert

Structuralism

Structuralism cannot be seen without the influence of post-war modernity in architecture as advocated by CIAM and later Team 10. As an important player in these platforms Aldo van Eyck is an early instigator of the values and structural, social approach to architecture that would define the later movement, his Burgerweeshuis being the most visible example. His students - Blom, Hertzberger, Van Stigt - would together with Van Eyck join in an intellectual architectural discussion searching for a reaction to the brutalist and inhumane tendencies of the modern movement. In articles and magazines like FORUM they assembled an ideology covering the social, human aspect of what new contemporary architecture should incorporate, focusing on buildings that facilitated equality and livability through a strong sense of human scale, humble materials and intended space for social interaction. One way of materialising these concepts that can be seen with all of these architects, would be a set-

up of repeating elements, spaces and parts of buildings in a structure to shape the whole of their buildings. These structural approaches theoretically allowed for flexibility, the ability to expand buildings in a continued pattern and the idea of a living building that was shaped by its users. The structure meant more to the individual architects than merely a gridded means of construction. However, while these aspects can be recognised in the work of these architects, to everyone it supported different ideals and possibilities, resulting in a great variety of material execution, though always maintaining the social aspect as the ultimate motive for designs. In the end this diversity results in buildings expressing very much the individual characteristics of the different architects, though all sorted in the same style through their shared structural grid and humane focus.

Blaakse Bos - Piet Blom

Structuralism in the work of Piet Blom is visible through three main aspects:

1. System

Multiple units contribute to one entity. Each unit or house is autonomous, in this he differs from other structuralist architects. This autonomy facilitated the multiplication of elements. Removing or adding one unit does not interrupt the design. The supercubes are exceptions, while still following this system.

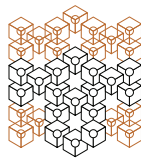

2. Social

Most importantly, the cube houses act as a framework in which social interaction can take place. Blom uses sightlines from the houses to street level, raised communal spaces and sequencing of open and narrow spaces to encourage people to interact and to occupy the spaces to make them their own.



3. Human Scale

Bloms vision of 'The city can be lived as a village' is materialised by the smaller spaces and multiplication of elements. Thereby creating a liveable space in contrast to the post-war redevelopment.



The transformation by Personal Architecture for one of the supercubes into an ex-detainees dwelling is a big incision to the original building. Are their interventions in line with structuralism?

1. Social interaction

The new central void replaces the central core and adds a visible connection between levels, thereby increasing interaction. Also, the new element in the void with its lounge gives line of sight to the surroundings. However, this intervention is not according to the original structural system due to the square plan.

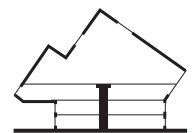

2. Exterior

The exterior of the supercube is not touched so the image of the building is not affected



3. Whitewashing

All interior surfaces are painted white. This repeals the original colour scheme. In addition the floors are replaced.



Burgerweeshuis - Aldo van Eijck

The structure of the Burgerweeshuis is defined by a system of living units that are structured in a diagonal, non-hierarchical way. The living units can function autonomously, but are connected by an 'inner street' and courtyards to create a whole. This allows for contact between the users and relations between the units.

The repetitive use of smaller construction elements such as the columns, architraves and cupola's gives the building uniformity and clarity as it creates a sense of human scale.

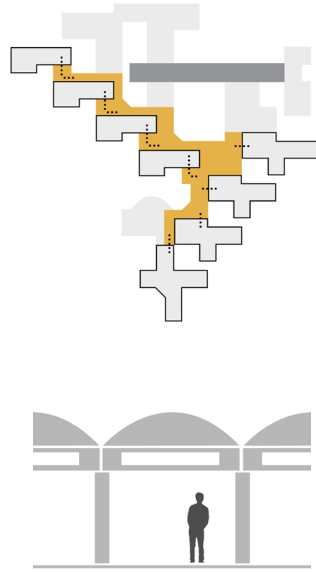

The main aim of the transformation was to revitalise the building. Subtle interventions are used to transform the building to modern standards while keeping the building's original principles intact. The former living units are now used as office departments that are able to function autonomously, but are connected to the 'inner-street' where the different employees are able to meet in an unforced manner.

Technical interventions are hidden away in the cover on the cupola's, also improving the acoustics of the building. The green facade color is removed to show the original material, creating uniformity.

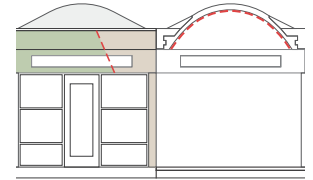

't Karregat - Frank van Klingeren

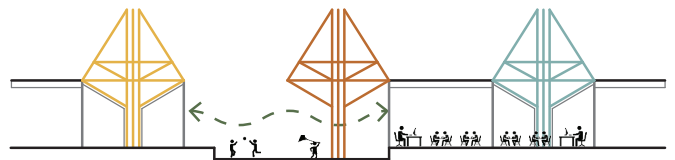
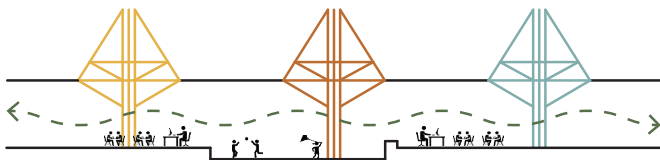

The essence of 't Karregat consists of a repetition of umbrella-like steel columns.

Repetitive system: The umbrella-like steel column and roof construction is made in modular components. The architect envisioned that this structure could later be expanded throughout the neighbourhood.

Social interaction: The ideas of declotting and hinder to create a better community.

The users own interpretation of the space: The fact that all the installations were placed in the roof zone meant that the floor space plan was flexible for change.

Transition between inside and outside spaces: multiple entrances were created from different sides and the use of a glass facade.

Experimental design solution: how to create a portion of the Dutch city.

Structuralism in the transformed building:

The building still has a social meeting function but it has been executed slightly differently and in a less extreme manner. The meeting places in the living room areas between the classrooms allow for social interactions.

Flexible walls allowing for multiple interpretations of the space.

Successful reuse of the existing structure is an interpretation of the flexible structure.

Vredenburg - Herman Hertzberger

Structural Gradient

As a function-specific building Vredenburg is shaped around the geometrically centred concert hall that sets the symmetry for the surrounding column structure. Designed from this central point outward the spaces and structural elements form a gradient from strict geometric repetition to environment-abiding lobbed facade compositions.

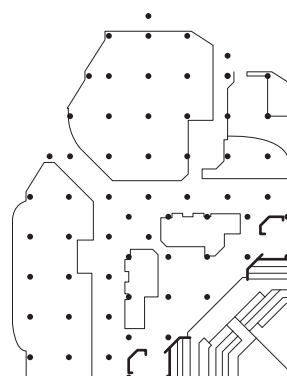

Transformation disconnection

With a new structure only connected by passageways in former outer facades and standing as a contrasting modern neolith beside the small-scaled old building the new addition of the transformation is in style, structure and interior almost completely disconnected from the existing concert hall, visibly showing the difference between old and new.

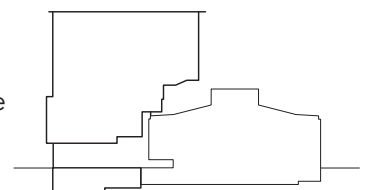



1. Blaakse bos (Cube houses) (1978)

Architect: Piet Blom

Location: Overblaak 70, Rotterdam

Group members: Joris Hartmans, Jelle Hetteema, Lydia de Vries

Piet Blom Blaakse os

Piet Blom was a Dutch architect, known for a number of notable projects, mostly built between the 1970's till 1990's. One of his most famous projects is the dwelling complex Blaakse Bos in Rotterdam, due to the extraordinary cube houses. Piet Blom was generally listed as one of the structuralist architects, together with Aldo van Eyck and Herman Hertzberger. His work has a strong focus on the social consequences of architecture, and is recognizable by the small elements contributing to a larger whole. However, the spacial expression of his work was in his words not important. He believed in the social effect that architecture can have on society, leading to his stubborn attitude. Due to his stubbornness not many of his projects are actually realised.

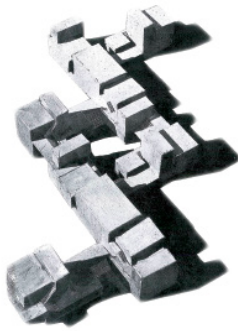

1934: Birth Piet Blom
Blom was born in the Amsterdam neighbourhood de Jordaan, at the time a dense and lively district. This atmosphere inspired his housing design during his career.

1959: Graduation project under supervision of Aldo van Eyck: "Cities will be lived like villages." This project aims to create a complex and compact form of urban architecture, comparable to his hometown Amsterdam and North African kasbahs. Interwoven functionality should give the neighbourhood a social and vibrant living conditions. Aldo van Eyck is impressed and uses this project at a CIAM congress as an answer to his own architectural questions.

1960: FORUM article stating the project is undoubtedly creating a humane living condition.

1900

1950

Oude Haven 1930
Busy cultural centre of Rotterdam, with the highest building in Europe: het Witte Huis.

1940: Rotterdam bombed
leaving the Blaak area destroyed.



By studying the Blaakse Bos dwelling project, we are researching the social and spatial characteristics of structuralism. Furthermore, this research aims to extract the values of structuralist design, and how they can be used in to accommodate contemporary needs.

How is structuralism represented in Bloms' design for the Blaakse Bos, and how does the recent transformations by Personal Architecture take into account the design decisions of Blom?

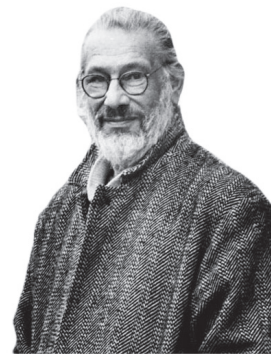

1973: Realisation *Kasbah* in Hengelo
This dwelling project is the first physical expression of Bloms' vision. Elevated houses make room for traffic and urban life including shops and playing areas underneath. It consists of 4 different types of dwelling, combining in a 184 houses neighbourhood. However, this project is built on the outskirts of Hengelo, not in an urban setting. Therefore the neighbourhood does not create the livelihood that was planned.

1975 - 76: Construction of first cube houses in Helmond. As a trial three houses are realised first. This test results in the theatre Speelhuis, composed of a large central cube containing the theatre, surrounded by 18 cube houses. The plan for the construction of 118 cube houses was put aside. This project is more conform to Bloms' theory, because the complex mixes several functions in a high density setting for the city centre of Helmond. In 2011 the theatre burnt down, the cube houses were damaged, but could me resqued.

1999: Death of Piet Blom while on holiday in Denmark.

2000

1984: Realisation of the Blaakse Bos in Rotterdam
For this project 78 cube houses were planned, but due to an economic crisis only 38 houses are realised together with two super cubes containing social functions. To finance the cube houses, two apartment buildings are constructed, namely the Blaaktoren and Spaanse Kade. The cube houses spanning the Blaak are based on the cube houses and are the culmination of Bloms' idea of living on the cities roof. Right in the centre of Rotterdam these cubes should resemble an urban forest. Between the 'trunks' are shops and other social functions. Furthermore the Spaanse Kade brings back the livelihood on the Oude Haven, combining dwelling and small-scale cafe's.

1993: Opening of *Willemspoortunnel*, lowering the railway.

2009: Stay okay hostel located in one of two supercubes.

1998: Replacement of asphalt roofing in favour of Zinc plating.

2013: One of the supercubes is transformed by the office *Personal Architecture*, turning the building into a dwelling for young exdetainees. The design has a significant impact on the original design, by creating a large open space the connection between floors is enlarged.

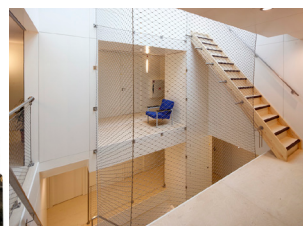

fig 1: Timeline collage

Process

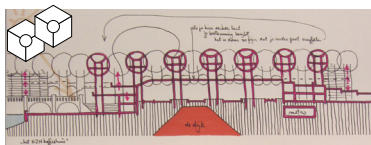

fig 2: first draft of Overblaak

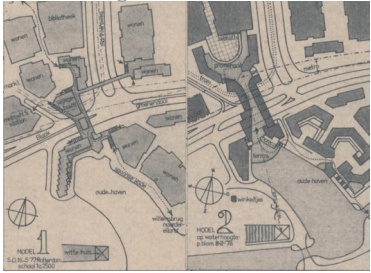
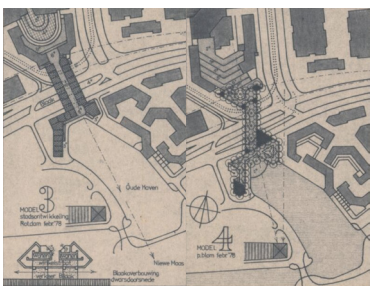

fig 3: Different models



'The promenade of Rotterdam only makes sense if it really becomes fairy-tale like and you can not stay away from it' is a statement Piet Blom made. In a first draft the cube houses were spherical. Blom made 4 models ('77-'78) for the passageway from Blaak to the Oude Haven, including a submerged underpass (model 2) and a bridge enclosed by shops and dwelling (model 3). The fourth model is more like a fabric within the urban environment. This proved to be most sufficient to the situation, combining dwelling, commercial space and an overpass over the busy road.

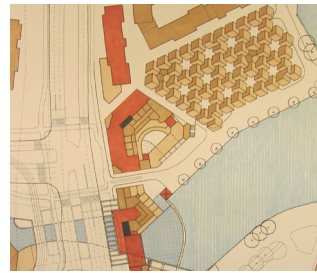

fig 4: alternative location

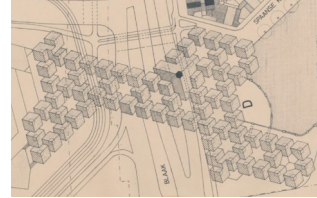

fig 5: first definitive design

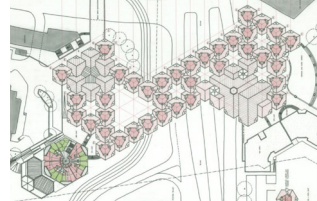
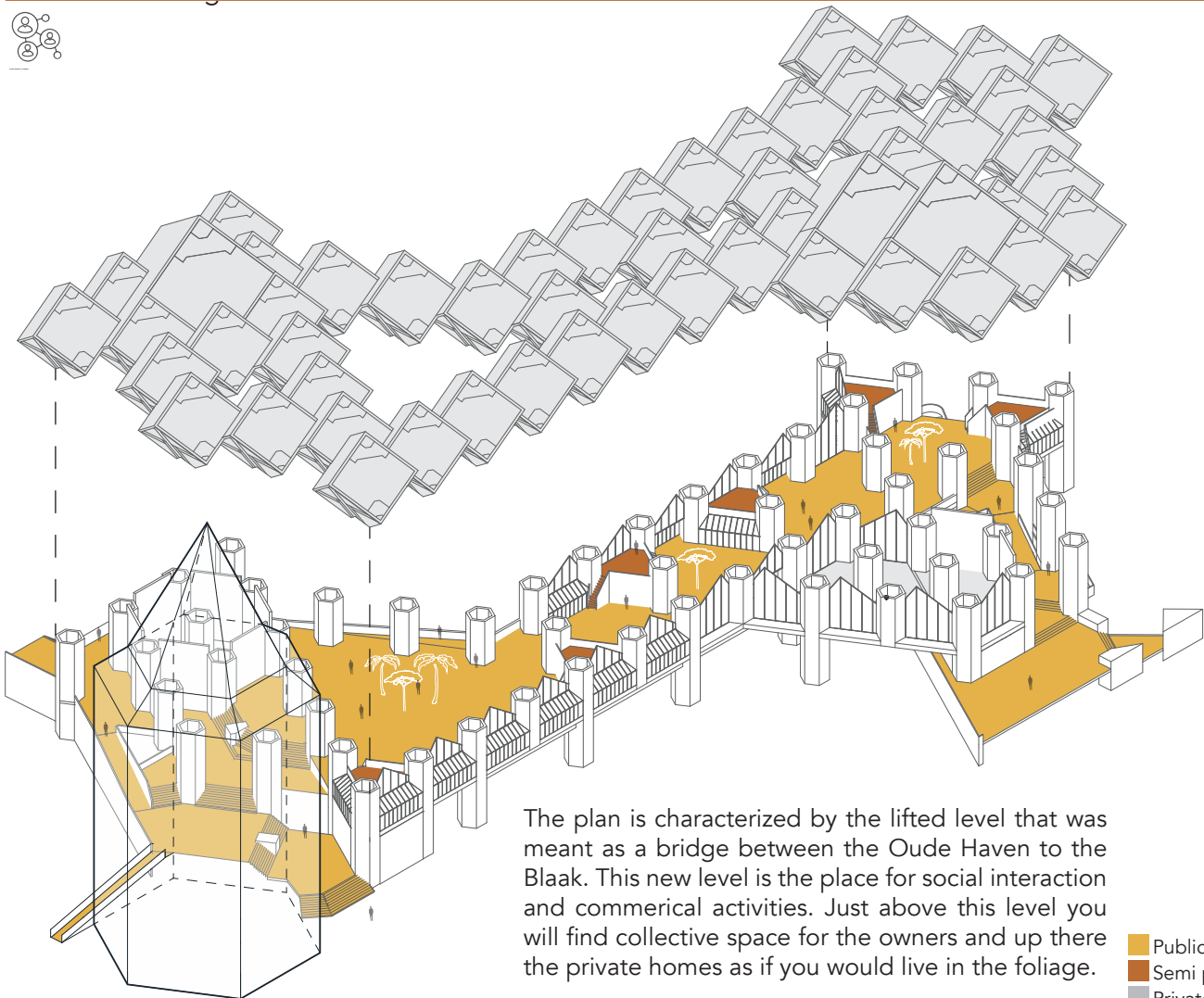

fig 6: final design

On 10 Jan. '78 Blom also proposed a different location for his cube houses, next to the Oude Haven. This in combination with the aforementioned underpass.

The first 'final' design (15 jun. '78) had cube houses along the Gelderse Kade, and featured a more gradual ascent via multiple staircases. In the end, this design was changed due to exceeding costs. Therefore, the number of cubic houses was reduced and the Blaaktoren and Zuidflat were added to provide sufficient dwelling.

Isometric drawing



The plan is characterized by the lifted level that was meant as a bridge between the Oude Haven to the Blaak. This new level is the place for social interaction and commercial activities. Just above this level you will find collective space for the owners and up there the private homes as if you would live in the foliage.

Public
Semi public
Private

fig 7: Axonometric drawing

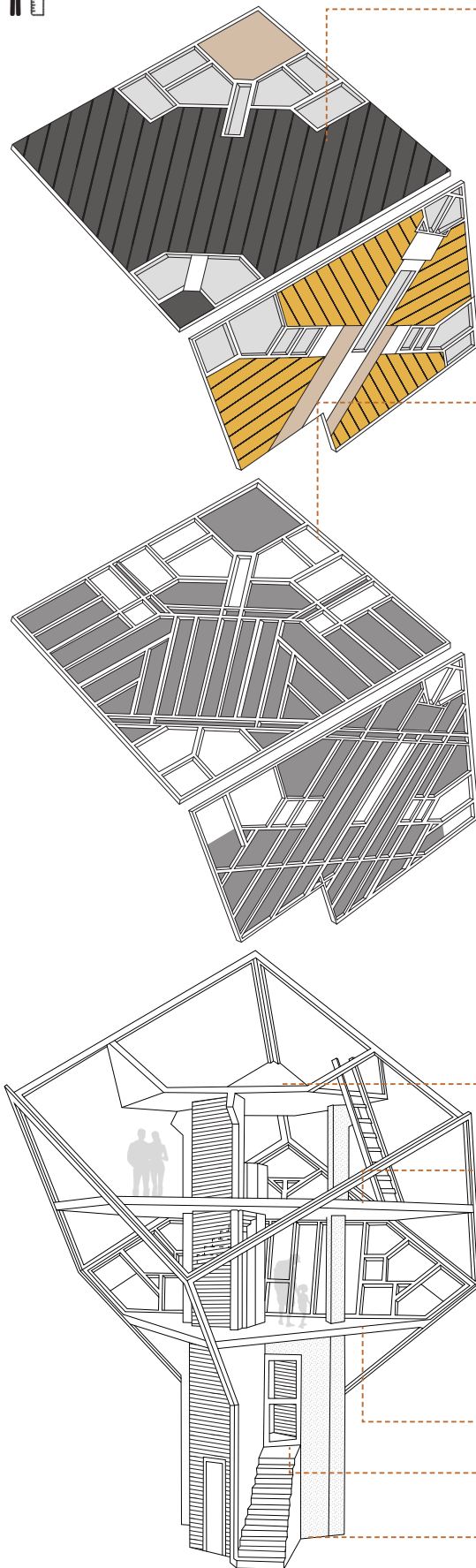

Roofing
Water drainage is integrated

1998: Replacing of asphalt roofing in favor of Zinc plating.

2015: Renovation by J.P. van Eesteren.

- New painting is applied (the well known yellow)
- The gable roofs are cleaned with impressive scaffolding
- Glass is replaced

Construction
Skeleton of wood, with isolation material in between the inner and outer facade. We assume Blom used wood for the construction because previously he was a carpenter, so he had knowledge about this material. If it was up to Blom himself he would have helped during the construction of the Cube houses.

The base/ trunk of the house is constructed out of concrete Hexagon, with a brick outer layer. In the floorplans three columns at the corners of the hexagon are visible. These columns are part of the load bearing structure and go up to the highest floor. The other floors are hung on to this floor.

"Loofhutje" +1040

Floor: Egaline leveling layer on 100mm concrete floor

"Hemelhuis" +780

- Bedrooms
- Floor: 50 mm cement finish layer
 - Ceiling: Spraying
 - Walls: Clean masonry
- Bathroom
- Floor: tiles 100x100
- Elevation
- Floor: plywood 22mm
 - Stairs: Iroko wood

"Straathuis" +500

Entrance +240

"Pothuis" 0

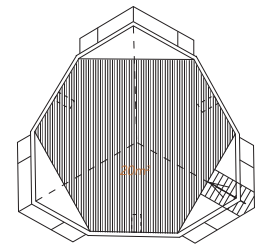

Loofhutje/ Plantenkas 20 m²

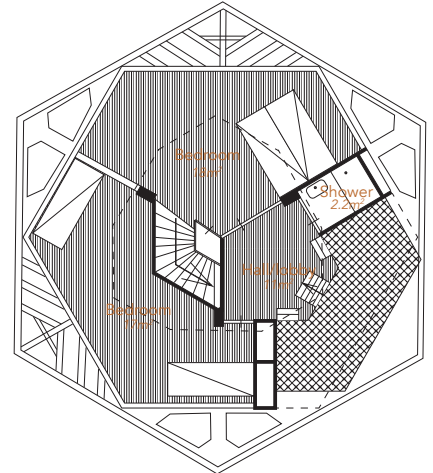

Bedroom floor 48,2 m²

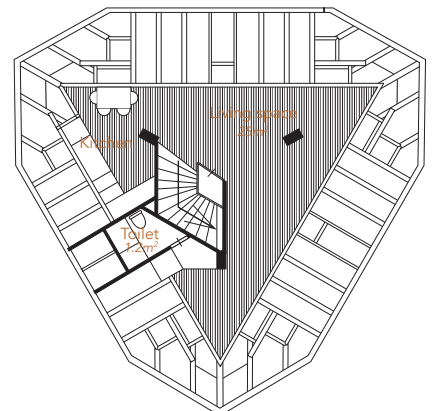

Living floor 26,2 m²

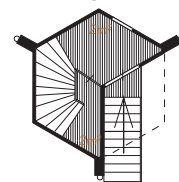

Entrance 4 m²

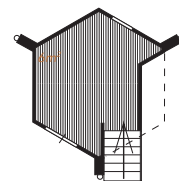

Pothuis 6 m²



fig 8: Cube house perspective

fig 9: Plan cube houses

Section

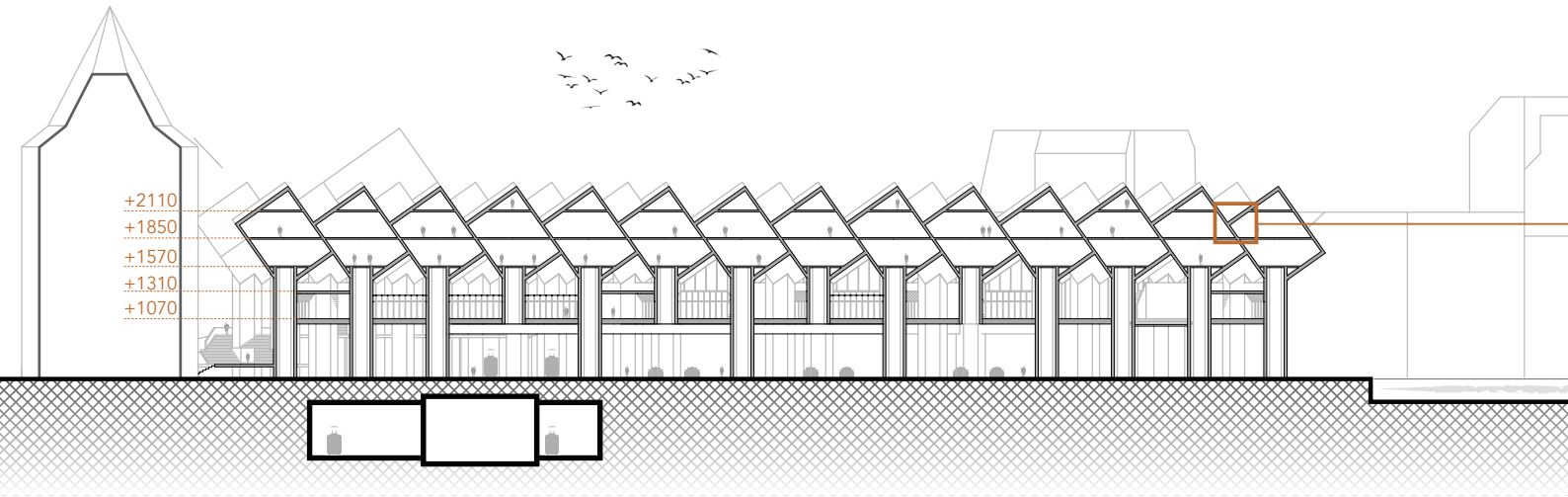

fig 10: section Overblaak

Plan | Route

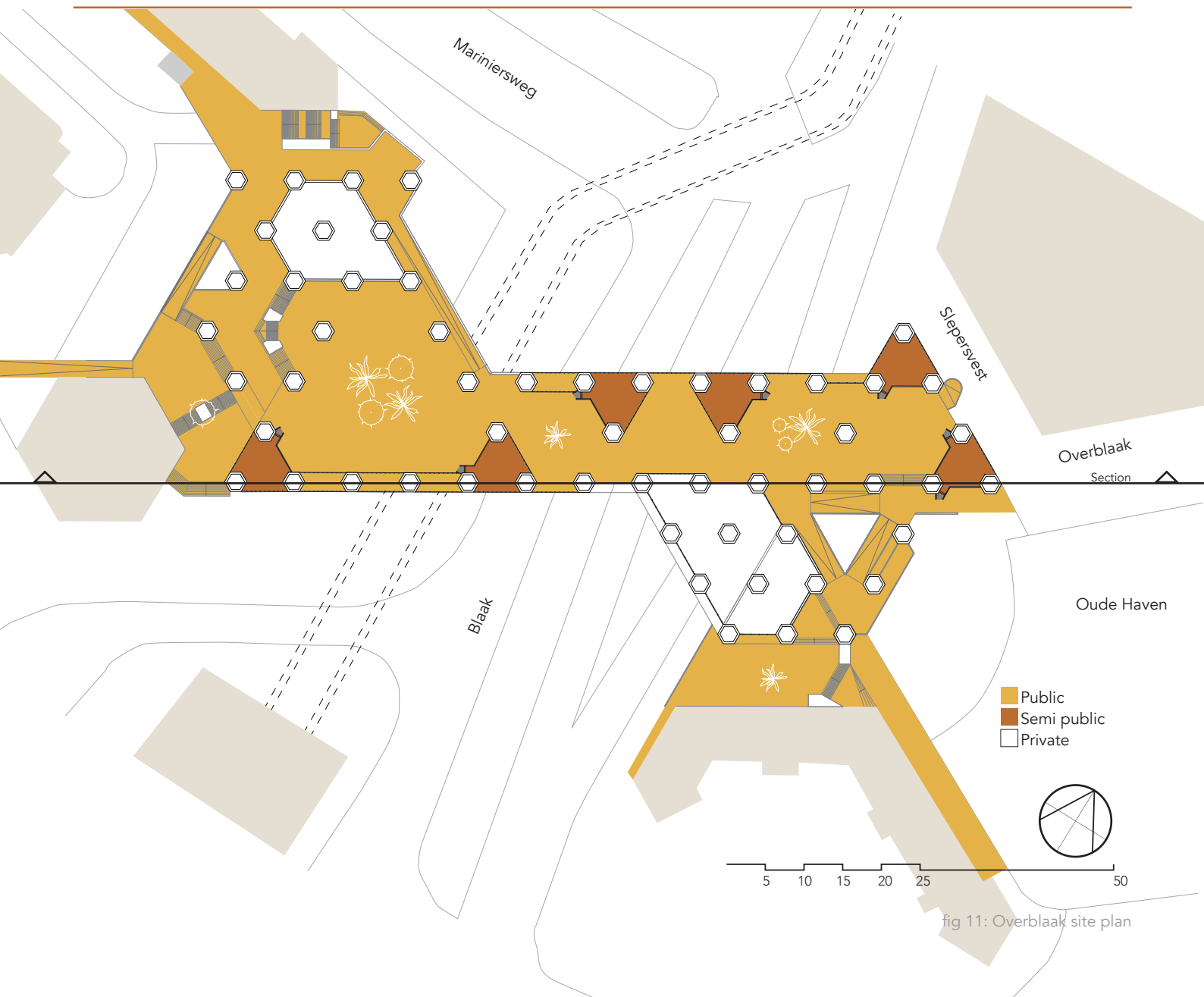

fig 11: Overblaak site plan

Detail

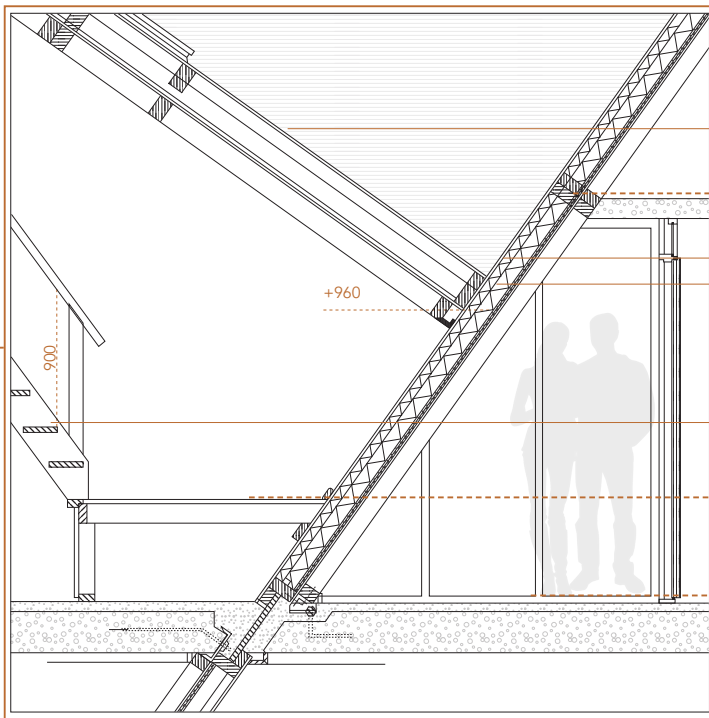

fig 12: Cube house detail

Plane construction from inside - outside

- Internal rules 67x90 mm
- Multiplex 15 mm
- Vapor barrier layer
- 9.5 mm plasterboard
- 9.5 mm plasterboard
- 70 mm of unpacked mineral wool isolation
- 50 mm wood cement plate isolation
- Outdoor alignment 67x90 mm / 67x139mm
- Plywood 20 mm
- Bottom plane:
 - 3mm duraform or cross strips of 3x80 mm duraform
- Top surface:
 - 5 mm promabest H + shingles

While the cube houses appear to have a separate construction, they are connected on the second floor through the construction. This floorslab is concrete 'en situ' giving the ensemble stability and rigidity.

Transformation

1998: Replacement of Asphalt roofing in favour of Zinc plating

2009: Stay Okay Hostel located in one of the supercubes.

The Hostel is located in 2 supercubes and 6 regular cubes. From the exterior you won't distinguish the hostel from the Masterplan. When you enter, you'll experience a big and open space. You won't experience the Cubes inside the hostel, an extra "fake" cube is therefore added.

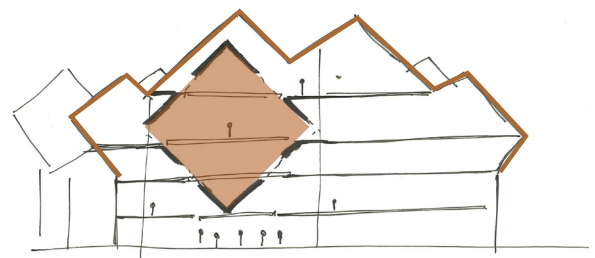

fig ? section sketch Stay Okay Hostel

2013: Transformation of one of the Super cubes by the office *Personal Architecture*.



fig ??: Photo's of the interior.

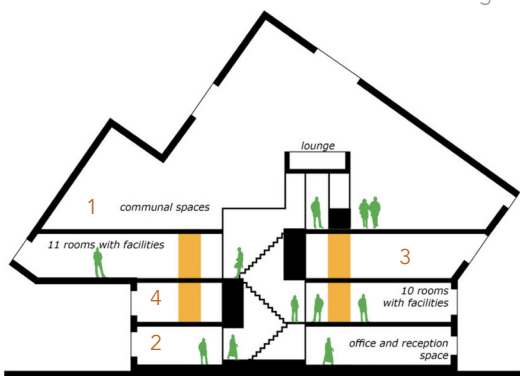

fig ??: Plan and section of Supercube



Again the exterior is un-harmed and stays equal to the houses. One Supercube is used as the center of the foundation and deployed for vertical movement. Spatiality and daylight is strengthened by a void through the core of this cube. Around this core the rooms of the ex-prisoners is situated. Colors and material are very neutral to create a clean and bright space.

2015: Renovation by J.P. van Eestereren, New painting of the well known yellow is applied, the gable roofs are cleaned and the glass is replaced.

Experience

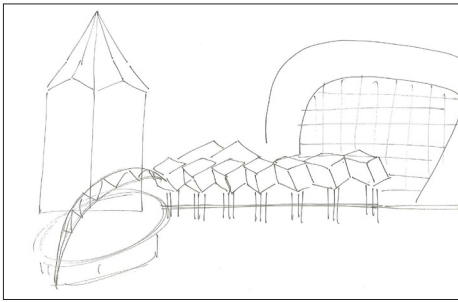

Icons on site

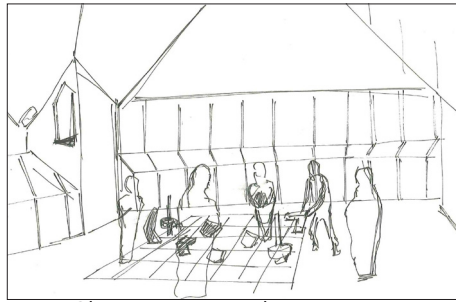

Chess as a social interaction

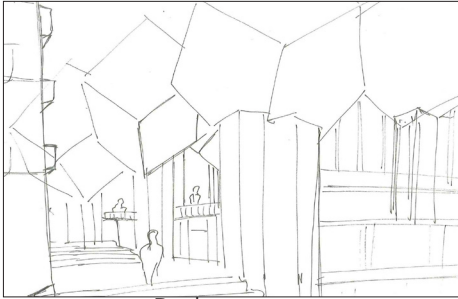

Bad entrance

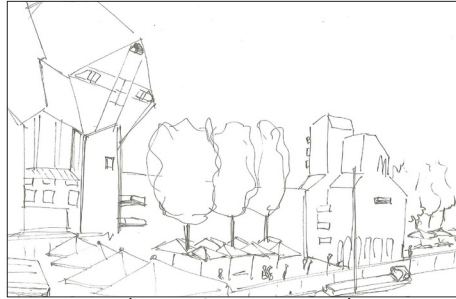

Vibrant Spaanse Kade

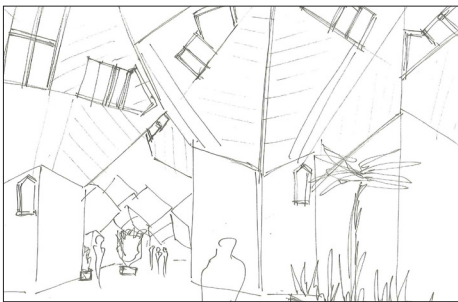

View Blaakse Bos

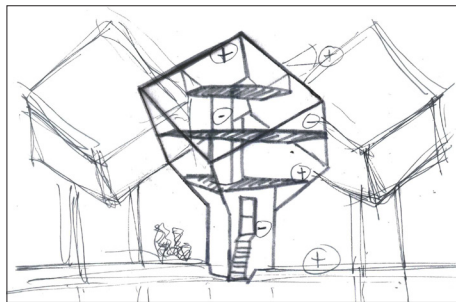

Interior Cube house

Standing in front of the project you notice the variety of architecture. Many tourists are interested in the cube houses and climb up the stairs to the "kijkkubus" and Hostel. The inhabitants of the city prefer to cross the road instead of using the overpass due to the bad entrance, the stairs are experienced as a threshold. Once arrived in the public space of the "Blaakse Bos" you feel in a different world. A smaller scale and the feeling of social control is very strong. In this space there are multiple elements placed to stimulate the social interaction, for example the plants and the game of chess on the floor.

On the east side of the Blaak you will find the vibrant Spaanse Kade. The atmosphere has much character because of the old boats, the water and "het witte huis". Many bars and restaurants are located in this Oude Haven and creates a busy city life.

The cube itself has a narrow entrance, but an open living space with a lot of light and view on the public space. The sleeping level is darker and the walls are moving towards you. In the top it is very light again and you will have a view on the roofs and skyline of Rotterdam.

Many colors are used besides the grey colors of stone and concrete. These colors are used to bring back the happiness into the project.

Colour Scheme



Structuralism

In the Blaakse Bos structuralism is visible through three aspects: *System, Social and Human scale*. In combination with our own experience of the Blaakse Bos we can draw a conclusion with positive and negative points of Piet Blom's design.

+ Although it wasn't Blom's plan, the Cube houses became an Icon of the Blaak area. Together with other icons, Blaak is a very attractive area for tourists.

+ Blom wanted to create a liveliness area inside the city of Rotterdam; A town inside a city. The Spaanse kade is part of the design with this lively atmosphere.

- The structure is flexible during the design process, were it is possible to add or delete certain elements/cubes to the design. After the realization it is more difficult to change the structure since the floors, on one level, form a plane. The framework itself doesn't leave much room for new interpretation by the people, unless the object or the frame is upscaled, like in the supercubes.

- The plan was to construct a connection between the market side and the harbour side with a bridge design. The design forms no 'good' urban connection in the context since it is faster to cross the road on the ground floor.

+/- Through the tilted planes with windows the inhabitants of the cube houses have a view on the public areas in between. When you access these public areas you experience little privacy because of this 'social control' of the inhabitants.

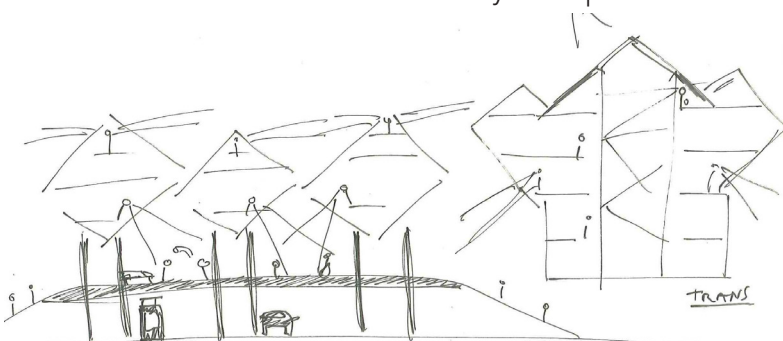



2. Raadhuis Ter Aar (1970)

Architect: Joop van Stigt
Location: Aardamseweg 4, Ter Aar
Group members: Marjan Sadeghi



Fig 1 :Joop Van Stigt , 1965-1970/1990-1992

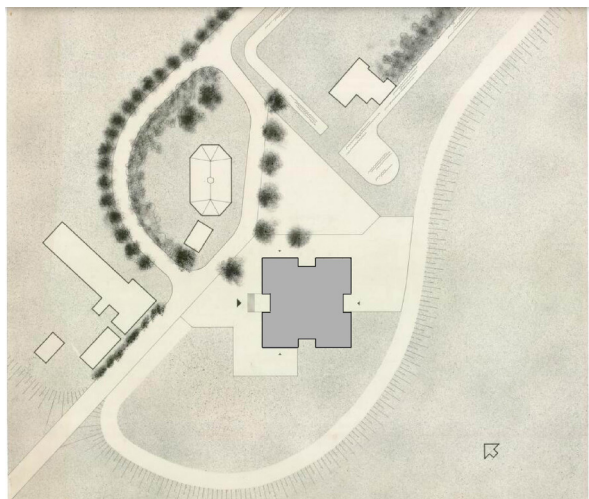

Fig 2: Site plan of church and old raadhuis



Fig 3 :Raadhuis,1970 with church on the left

Structuralisme

Dutch Structuralism, as an architectural movement, was founded by the so called FORUM-group. According to the FORUM-group, modern architecture resulted in too uniform, too large-scaled and anonymous buildings that are unable to react on future developments. They believed Modernism killed creativity and forgot the humanity. So they seeking for design with larger social impact.

According to van Heuvel there are several characteristics of Structuralism. Firstly, the construction structures space and creates flexibility. It allows growth and cohesion and is part of the architecture in both the interior exterior. Secondly, the human being and its relations is the starting point for every design. The buildings were designed in order for people to meet and interact. Thirdly, the building can be seen as a configuration that consists of smaller units that are subject to individual interpretation but still form a coherent whole in which collectivity can enter. Finally, instead of dividing the different monovalent functions. Structuralism strives for a mixture of functions and spaces that can be used in multiple ways.

Dutch Structuralism represents one of the most important moments in the development of twentieth century architecture in the Netherlands, and left rich architectural and cultural values.

This booklet mainly focus on the analysis of six iconic projects of Dutch Structuralism. By analyzing these projects and their architects, we could have a better understanding on the development of Dutch Structuralism.

Joop Van Stigt , 1965-1970/1990-1992

Joop van Stigt was the architect of Raadhuis Ter Aar. His motivation to become an architect was rather unusual. He was born in Amsterdam in a large family of fourteen children. His older brother would become a missionary and Joop van Stigt decided that if his brother became a priest then he would need to build churches. His brother didn't become a missionary but he did become an architect. In the ten years which it took for him to complete his study, he worked full time at a construction company (GevellRaad, 1999). As a result he understood the fundamentals of construction well. Later he gained practical experience working at Bodon, Van der Linden, Aldo van Eyck and Boon and finally started his own practice.

What makes Raadhuis Ter Aar a structuralist building and what values does this offer?

The municipality wanted a building which would be situated in the polder landscape of Ter Aar and to make the interaction between the geographic place, the historical context, between the municipal workers and the local citizens (Steenhuis, 2014). The vision of the client together with the methodology used by the architect a unique structuralist building was created in on the outskirts of Ter Aar.

Several characteristics appear more frequently in the buildings designed from a structuralist mentality. These characteristics are to be highlighted in the next few pages. The findings from the analysis highlight the values that this structuralist building provides.

Configurative design using a modular unit

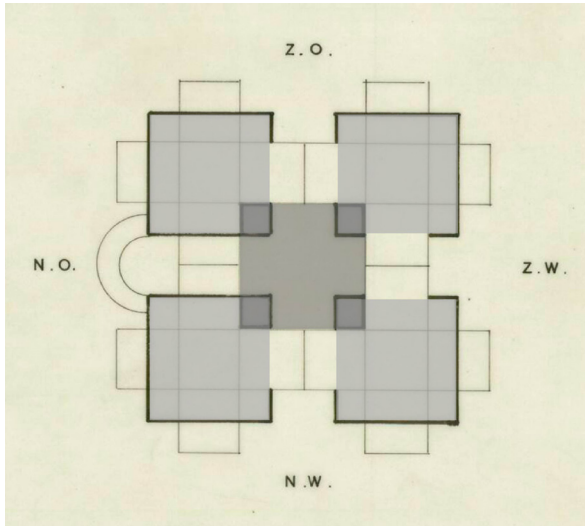

The module of 11m x11m is arranged in an interlocking pattern in plan to create the following form. The plan of Raadhuis Ter Aar by Joop van Stigt has a strong geometrical character. It's centralized and symmetrical composition with grand steps shows clear relation to the work of Renaissance architect Palladio (Villa Rotonda). At the same time, the geometrical shape (use of squares) and the division between the "serving" and "served" space using structural vacant columns was clearly influenced by the works of Louis Kahn (Tremble Bath House). As one of the best students of Aldo van Eyck, Joop also redeveloped the social and spatial ideas of van Eyck. By creating the public atrium and the open office space using what can be call configuration design (interlocking squares), Joop meant to stimulate social interaction between the public and the civil servants in the town hall.

Fig 4 : Abstraction plan of the building, scanned from Het Nieuwe Instituut archive. 1965

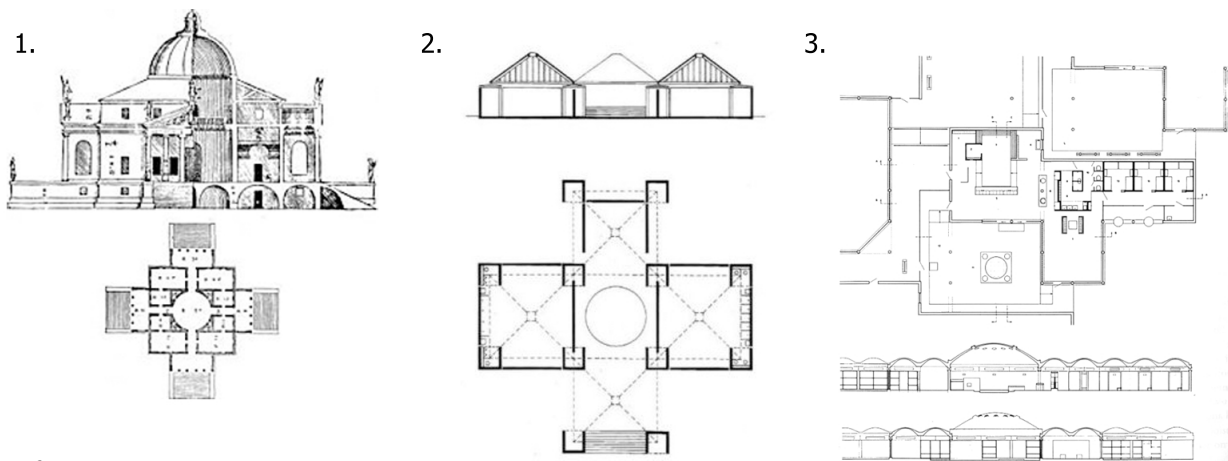
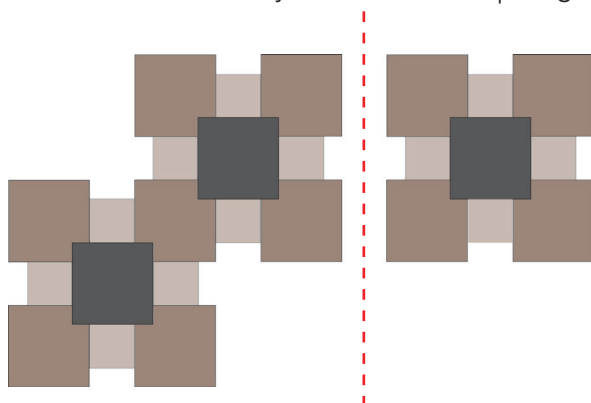

Fig 5 : References

References which could have had an influence on joop van stigt design process

1. 1571 palladio villa Rotonde.
2. 1955 Louis Kahn Bath House.
3. 1060 Aldo van Eyck Amsterdam Orphanage.



Configurative design using a modular unit

Later an additional three modules were added for the municipality extension. In 1991 the extension to the Raadhuis was made using the similar concept of the interlocking square block. The extension was needed to provide a canteen space and storage rooms for the municipality. The new extension is reached by people through the new main entrance on the ground floor.

Fig 6 : Concept diagram on right and 1992 addition on left

Program

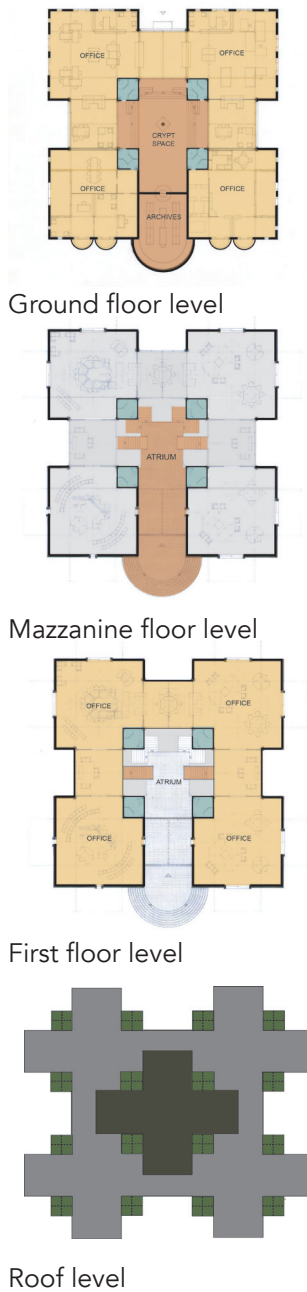

Fig 7

The roof is extended 2,5m out over the façade in order to express the structure of the roof to the viewer on the ground. The cross structure of the roof is dominant in determining the hierarchy of public and private space in the interior. The edges are more private and the centre walk ways are more public. Spatial connections.

The atrium is the interlocking space and it was conceived as the most public space in the town hall. The three zones of the atrium are the darker crypt-like area, the public platform and the lifted roof with windows bringing light into the atrium and onto the structure.

Open plan offices look onto the atrium from four sides.

The double height hall is 1,5m higher than the ground level of the polder landscape and it forms a connection with these service/help desk spaces on the ground floor and the managers on the first floor. The crypt like space below the double height hall is supported by a central column with exposed concrete aggregate concrete finishes. This space then leads to the door of the archive store.

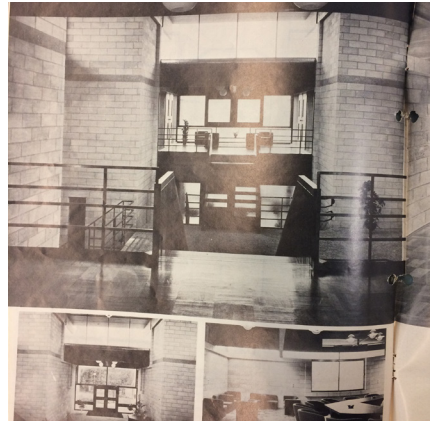

Fig 8: Mazzanine floor level

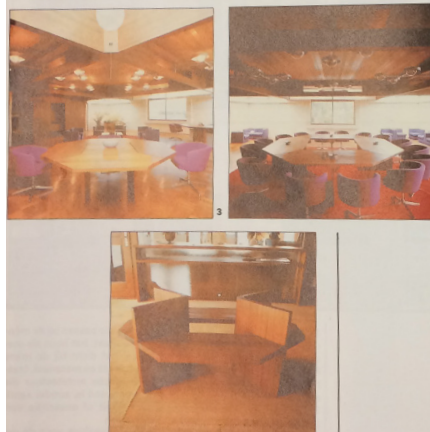
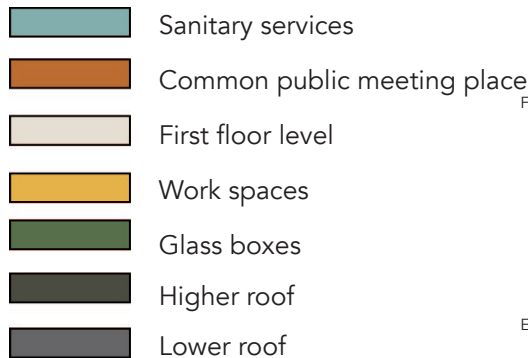
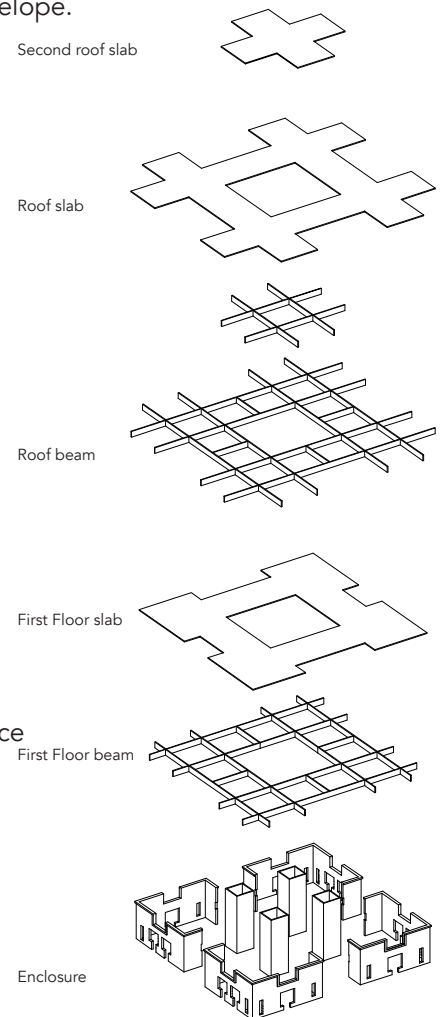

Fig 9: Offices



Building structure and materials

Everything in prefabricated elements to be put together in a similar manner as a furniture set. The basic scheme is an interwoven grid of wooden crosses, overlapping square that interlock. The form language that is associated with structuralism was not to have a certain purpose. The craftsmanship in the buildings of van Stigt were more important than the envelope.



Interlocking space

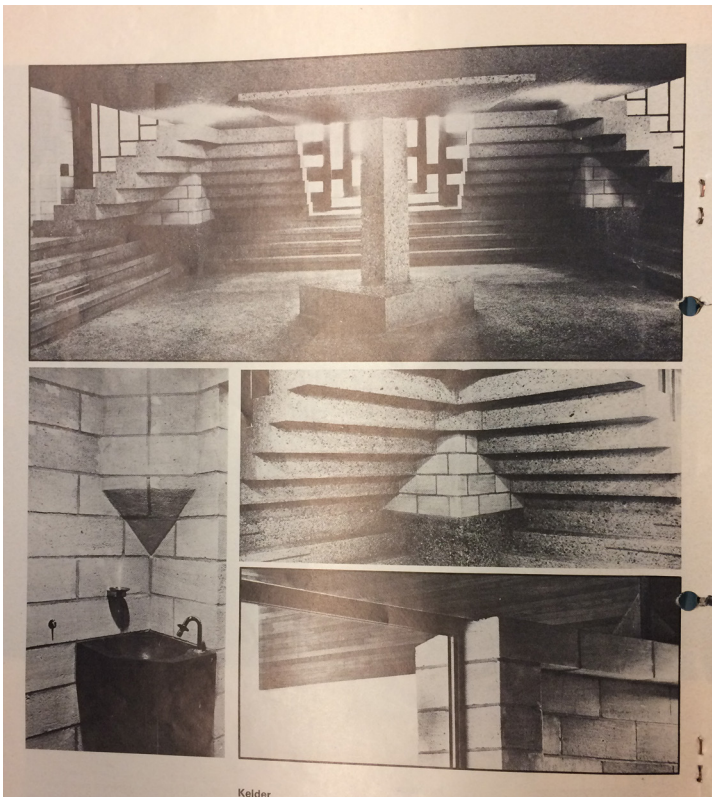

Fig 10: Spatial connections

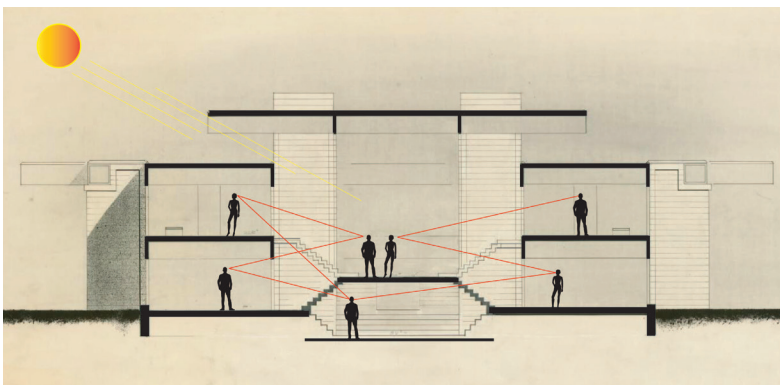

Fig 11: Interaction

The atrium is the interlocking space and it was conceived as the most public space in the town hall. The three zones of the atrium are the darker crypt-like area, the public platform and the lifted roof with windows bring light into the atrium and onto the structure.

Open plan offices look onto the atrium from four sides. The double height hall is 1,5m higher than the ground level of the polder landscape and it forms a connection with the service/help desk spaces on the ground floor and the managers on the first floor. The crypt like space below the double height hall is supported by a central column with exposed concrete aggregate concrete finishes. This space then leads to the door of the archive store.

Installations

Due to largely updated facility systems, change of building regulations and increased sustainable requirements during the past 50 years. Large amount of equipment ducts and pipes were placed on top of the rooftop, through the slabs and along side the timber beams. They appear to be located in a unorganized way and are unavoidably interrupting the original spatial experiences and taking up space inefficiently.



Fig 12: Photo of installations

Materiality

Apart from the aging of lime stone both in interior space and on facade, most of the materials and details are conserved as their initial design. The combination of stone, red wood, bronze frames and washed concrete are not in good quality both technologically and aesthetically. They still shape a welcome atmosphere of the atrium as it was in 1960s.

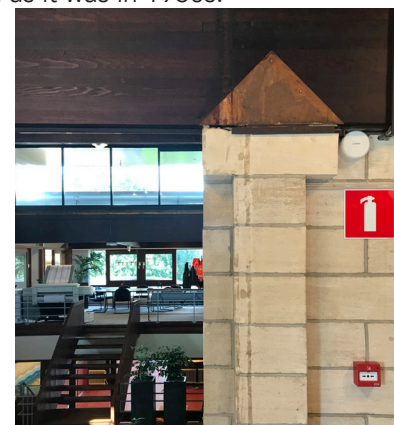

Fig 13: Photo of lime stone and red wood

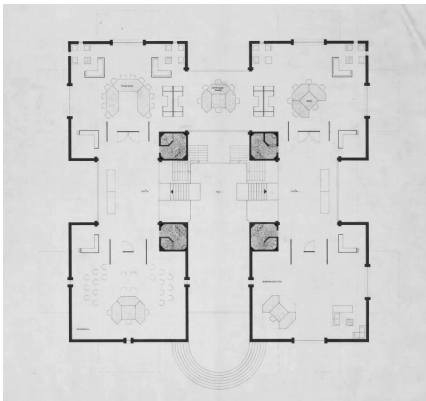

Fig 14: Original first floor plan

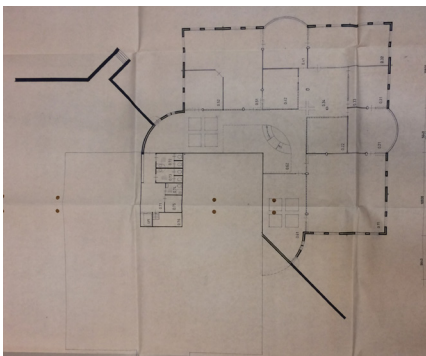

Fig 15: Sketches for addition

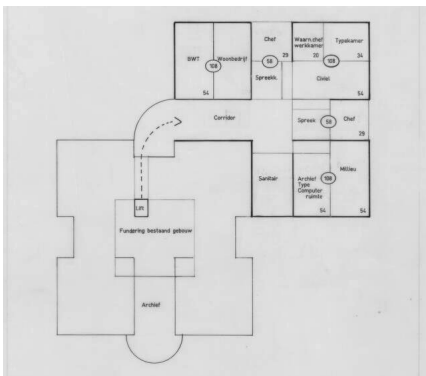

Fig 16: 1992 ground floor addition

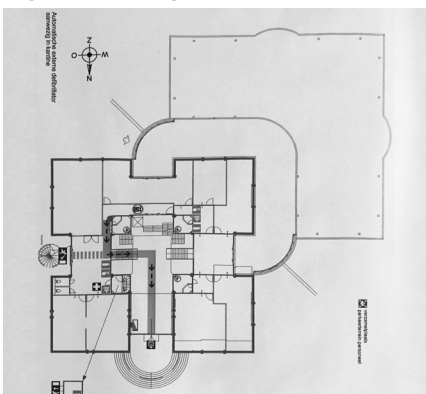

Fig 17: New space planning and entrance

1965

1991

2006

The complexities of current building can be regarded as a result of social, economical and functional changes through almost 50 years of time. In 1965, the whole planning appeared to be a huge "room" shared by both the municipal workers and visitors. With no solid separations or enclosed space which are usually considered as rooms, structures elements, spatial compositions and even furnitures were all designed in order to shape a plural, flexible and public space.

An extension was conducted with the same logic of interlock squares in planning in 1991 and offered more serving space for functional considerations.

Situations of the building by the time of our visit is a result of the renovation in 2006 when the building was transformed into a private office for a company. The formal entrance using big stairs was abandoned signifying the disappearance of publicity. With all the fundamental structural elements kept as initial, additional walls were added for separating private office areas and reorganizing the circulation. Two more toilet rooms were disturbingly placed in what used to be a bright corner with skylight in the original design. A glass elevator was added in the corner of the atrium for more friendly usage and all original furnitures which offered possibilities for flexibility were removed.

Even though to some extent, later occupations and separations did prove the potential for adaptability and exposed the functional problems during its usage, the renovations on site have largely damaged the original spatial order and the correspondence between spatial experience and functional, social ideas.



Fig 18: External collage render of 1992 additions

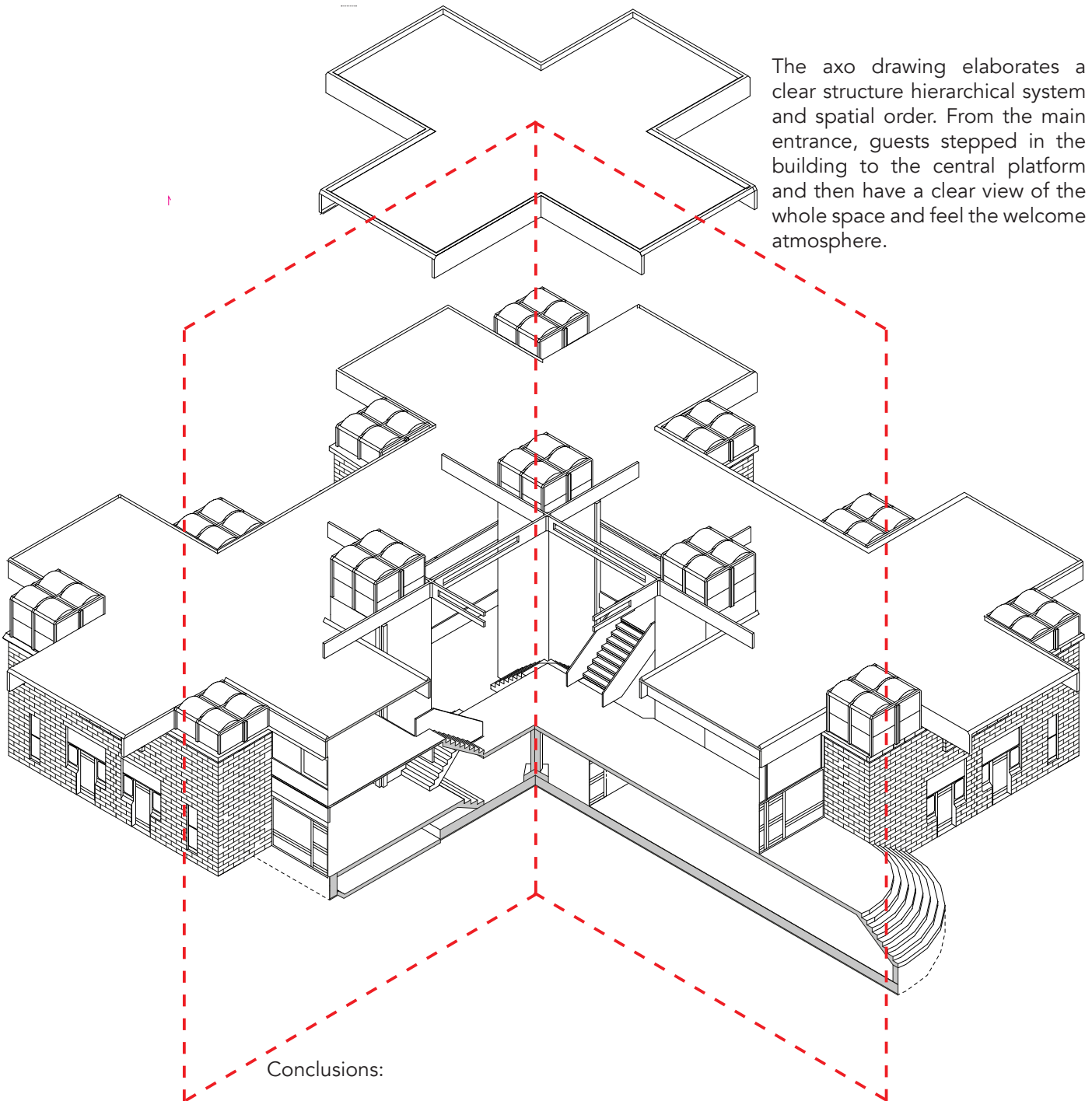

The axo drawing elaborates a clear structure hierarchical system and spatial order. From the main entrance, guests stepped in the building to the central platform and then have a clear view of the whole space and feel the welcome atmosphere.

Conclusions:

The analysis of Joop van Stigt for Raadhuis Ter Aar from the drawing and documents in the archives, lecture from Francis Strauven, and tour of the site with the municipality's maintenance manager has brought the following points to our attention:

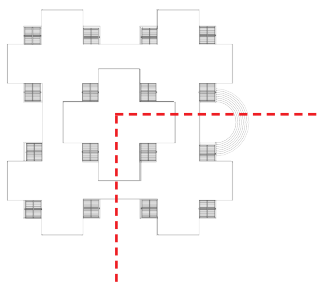

1. Flexibility. Structure which can be rigid to hold a flexible and variety of activities. Express the structure as a building finish. Clear to see the logic of the structure
2. Social interactions. Rethinking how people meet and interact with one another as a result of the built form.
3. Use of materials. Most relevant technological systems eg. glass roof structures.
4. Structurally sound. Calculation of the structure all done by the architect himself. No need for a structural engineer.
6. Connection to nature. The design for the new town hall for Ter Aar is part of the evolution of our work environments and ways of working. The own plan town hall is situated out of the city centre and surrounded by grass and green. This is an indication of the decentralisation of the city's public buildings as a result to be in connection to nature.



3. Amsterdam Burgerweeshuis (1960)

Architect: Aldo van Eyck

Location: IJsbaanpad 3, Amsterdam

Group members: Jelmer Dankers, Valery Eshuis, Jonathan Verhoef

Amsterdam Burgerweeshuis (1960)

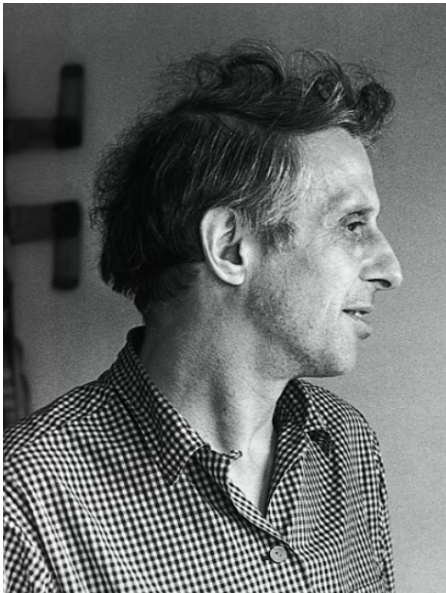

fig 1: Aldo van Eyck

Aldo van Eyck

Aldo van Eyck, born in 1918 in Driebergen, the Netherlands, was a Dutch architect. He grew up in London and graduated in Zürich. After being a member of CIAM, Aldo van Eyck was in 1956 one of the founding members of Team 10, a group of young architects that discuss and criticize architecture and each others work. One of their collective ideas was found in criticism on post-war modernism, mainly for a lack of human element.

The first building of this new generation of architects that was realized was the Burgerweeshuis, a building that was a first step towards architecture that would later be defined as structuralism.

Playgrounds



fig 2: playground Zaanhof Amsterdam by Aldo van Eyck

Before building his first building Van Eyck designed hundreds of playgrounds for the city of Amsterdam.

These playgrounds can be seen as exercises in relativity and non-hierarchical compositions, as the mutual relationship of elements was essential and they are all equal. The modularity of the playgrounds was also essential for the designs, as in different cases the same playing elements were used, yet arranged differently to fit the specific surroundings.

The principles used for designing the playgrounds can later be found in the architecture of Aldo van Eyck.



fig 4: Birds-eye view of the building in its (lack of) context

Burgerweeshuis

The reason the former director of the Amsterdam Orphanage, Frans van Meurs, chose for Van Eyck as the architect for the new Orphanage was because of the way Van Eyck's ideas matched the desires that Van Meurs had for his orphans.

He wanted to create a friendly building and an orphanage that would really be a home for the children.

He wanted to create a place where children of all age groups had to grow up with a certain level of independence, but would be in contact with one another in an unforced manner.



fig 3: A child playing in the orphanage

Location

The Orphanage was built on the periphery of city of Amsterdam. It was located on the edge of the city close to the olympic stadium and surrounded by polders. It was built there because Frans van Meurs had a "desire to move his orphans away from the bustle of the inner city to a small, ideal world bathed in healthy air, sunshine and greenery."

Later though the surroundings of the Orphanage got built and it was no longer located in green surroundings. In the early 90's the Tripolis towers were built (to a design of Van Eyck and his wife) right next to the site, but the Burgerweeshuis was at the time no longer in use as an orphanage.

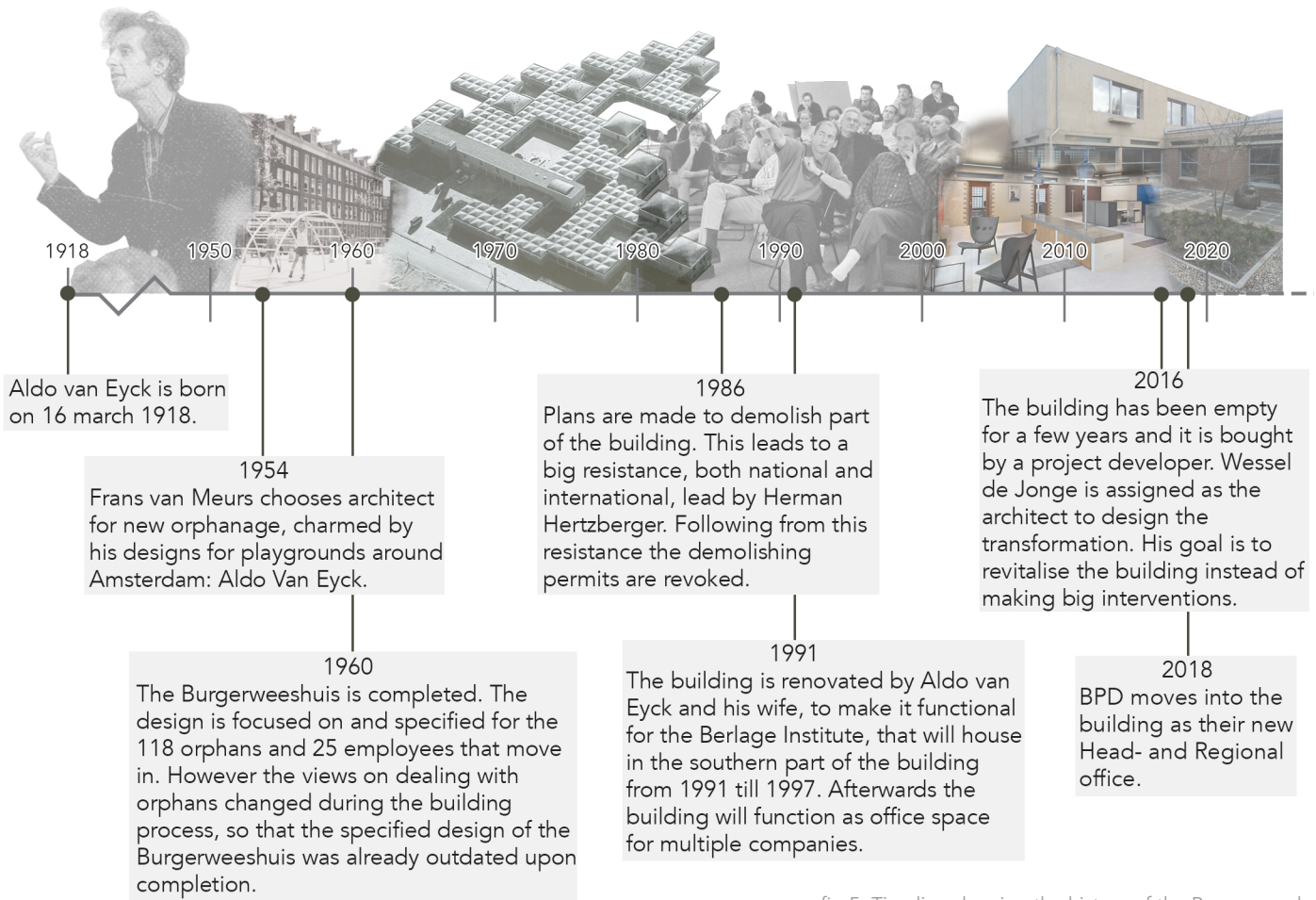

fig 5: Timeline showing the history of the Burgerweeshuis

Transformation

In 2016 Wessel de Jonge got assigned as the architect to transform the Burgerweeshuis to make it more functional as office space and make it more efficient and sustainable by creating a modern-day level of thermal and acoustic performance inside. The approach to this design by Wessel de Jonge was to revitalise the building and use the principles and ideas implemented by Aldo van Eyck, rather than making big interventions.

The building as it was designed has the qualities to function as an office space. The building units can function as autonomous elements allowing them to house different departments. The inner street connects the units and allows for unforced interaction, creating a workspace that is informal and gives the employees a feeling of freedom. The places where children used to play football and run around playing are now places where employees of different departments meet, which improves the company as an organisation.

The biggest interventions made during the transformation are on a technical level, where for example the installations and wiring have been hidden in the new ceiling covering.

In 2018 BPD moved into the building as their head- and regional office. Next to office they also offer a public exposition in the building to expose their private collection of art. The interior for BPD has been designed by Odette Ex of Ex Interiors.



fig 6: Addition from 1991 as meeting room



fig 7: Interior design, using existing elements

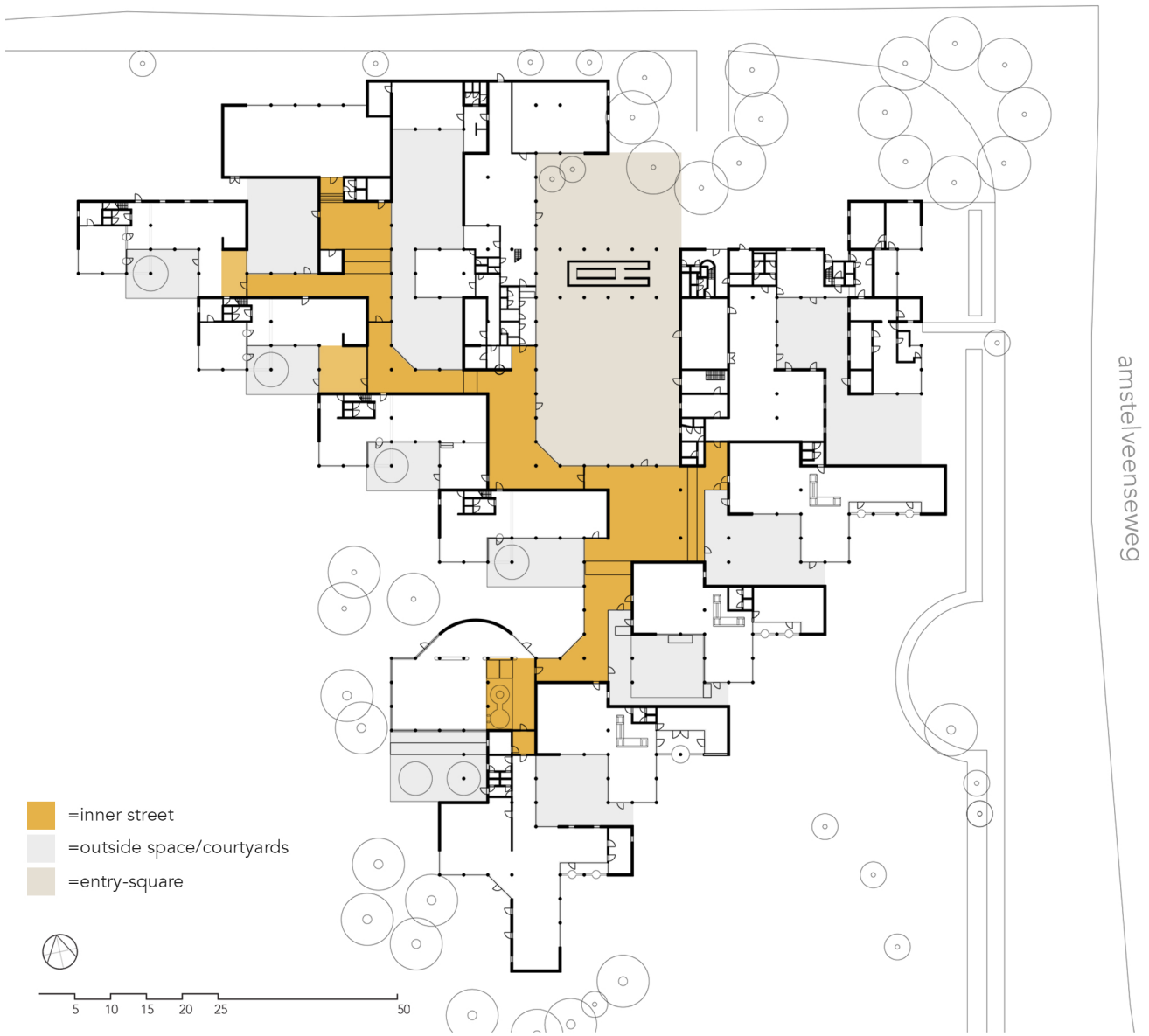

fig 8: Groundfloorplan with the 'inner street' and outside space highlighted

Coherence through interstitial spaces

Inbetween the elements is interstitial space that functions as a connection that creates coherence and connection between them. This is space where the users of the autonomous units meet in an unforced manner.

This has been implemented in the building in multiple ways. The interior connection between the elements is created by a diagonal 'inner street' that creates a non-hierarchical connection. Also a big courtyard is created in the middle of the building that allows for the user to enter the building through multiple entries. The space created

in the courtyard has been defined in multiple sizes by using architectural elements.

The connection between the living units is created through physically shared outside space and visual connections.

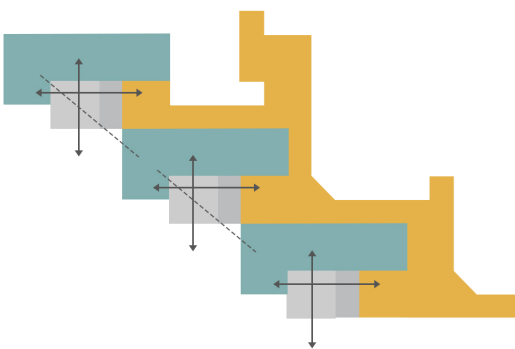

fig 9: Courtyards as connections scheme



fig 10: Photograph of the entry-square

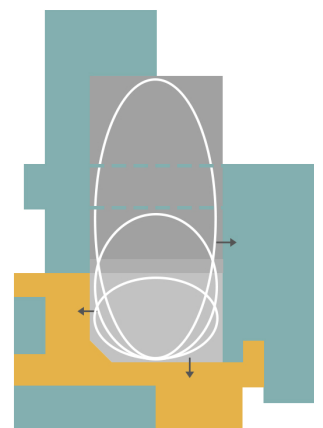

fig 11: Entry-square scheme

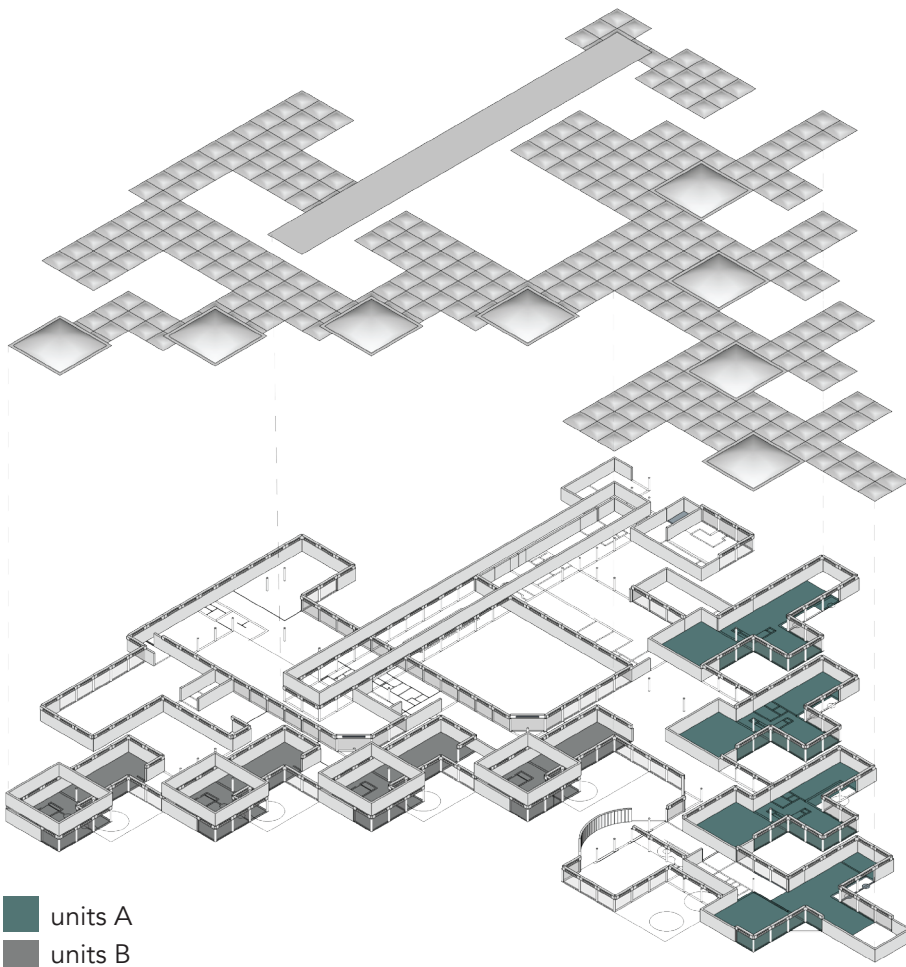

fig 15: Axonometric drawing of the Burgerweeshuis, showing the repetition of building units.

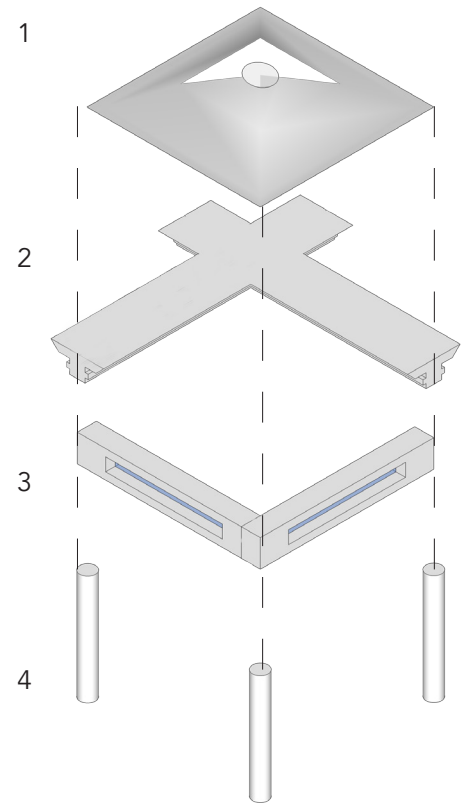

Fig 16: Elements used to build up the Burgerweeshuis

Genericity

The axonometric drawing shows the repetitive elements of the building that make up the primary structure. The building is made from prefab columns, architraves, and domes.

However some parts, like the floors, are cast concrete. From above the structure looks very ordered and generic.

Repeating elements:

- 1 Roof domes: 2 types, big and small. And some have rooflights and others don't.
- 2 Beam details.
- 3 Architraves with window frame.
- 4 Columns.

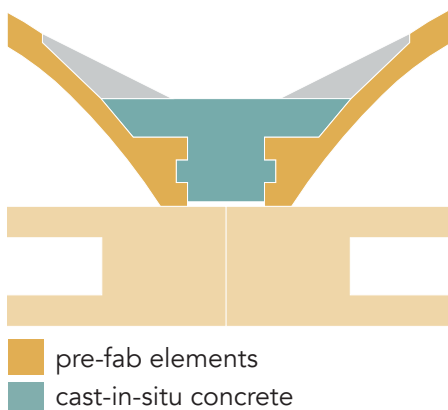

fig17: Diagram showing repetitive units.

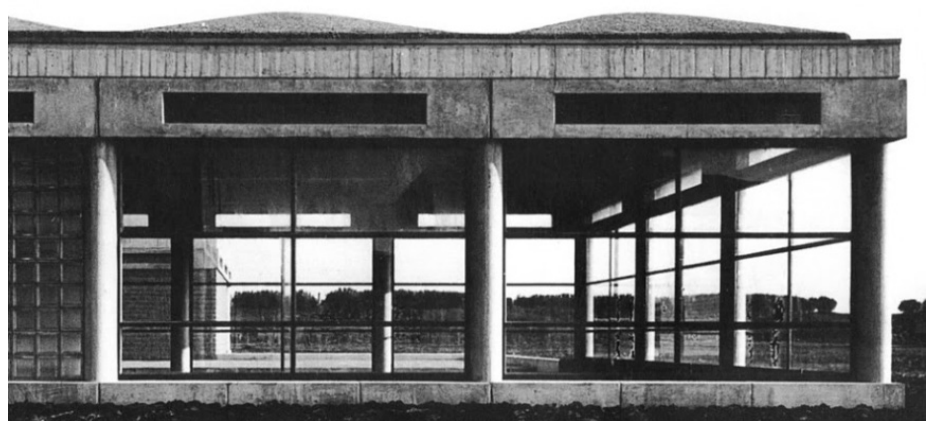
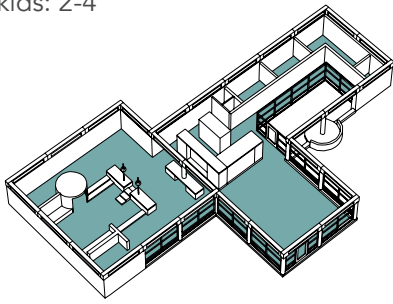
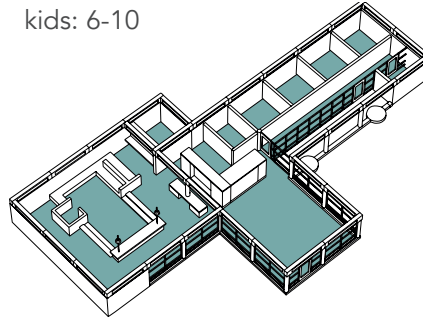

fig 18: Picture showing the elements combined, constructing the building

kids: 2-4



kids: 6-10



kids: 4-6

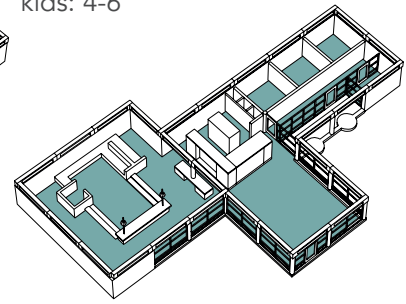
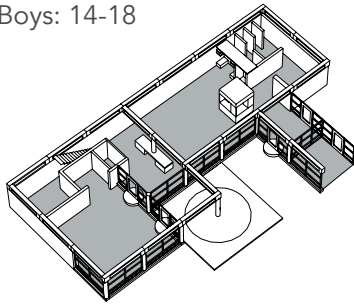
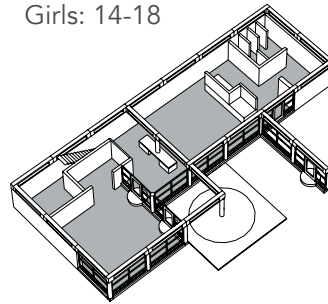

fig 19: Interior plan of units A

Boys: 14-18



Girls: 14-18



Boys: 10-14

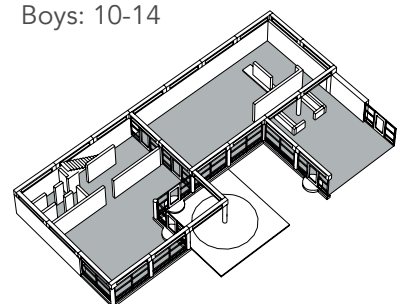

fig 20: Interior plan of units B

Specificity

Contrasting the repetitive application of the structural elements, the interior spaces are much more specifically designed. This can be seen in the original setup of the building units. These units were meant to be dwellings for specific groups of age and gender. And even the objects designed inside the dwelling were accustomed to the specific needs of the expected users (fig. 20).

The differences in height of the floors between different parts of the building is done deliberately to accommodate the older and younger children of the orphanage.

These height differences are seen in the hallway and the dwellings of the younger children.

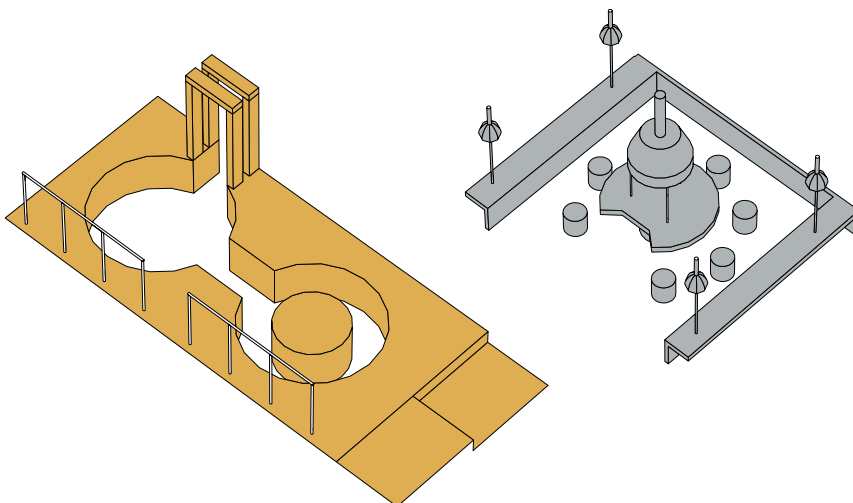

fig 21: Specific interior elements

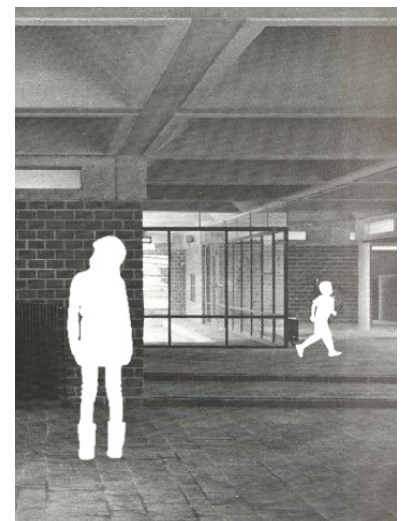

fig 22: Different floor heights accommodate different age categories.

Is the Burgerweeshuis an icon of structuralism?

The Burgerweeshuis is mentioned in literature as an example of structuralism. But when exploring the features of the building there are only a few aspects that can be referred to as structuralism and certainly not everything is structuralist about it.

The assessment of the observations

1. grid (pro)



fig 23: Diagram showing the modules of the Burgerweeshuis.

The buildings strictly follows a 3,36 x 3,36 m grid structure for the load bearing elements (columns and walls).

2. structural elements (pro)



fig 24: The recurring structural elements of the building.

The columns, architraves and domes are repeated single elements that together construct the building and create a uniform character throughout the building.

Conclusion

In structuralism the use of spaces and objects is left to be determined by the user. But in the orphanage the meaning seems to be embedded in the design. And this particular notion would oppose the claim that

(Fig 23 to 28) is meant to clarify what we do (pro) or do not (con) consider to be structuralist about the building.

Because structuralism is not understood uniformly by everyone we narrowed our research down to the description of the term as described by Herman Herzberger in the book 'Architectuur en

3. hallway and entrance square (pro)



fig 25: Entrance square and connecting hallway.

The hallway serves as a place where people moving from unit to unit can meet in an unforced manner. The hallway and entrance square have a rather egalitarian character.

4. variety in layout (con)



fig 26: Different facade execution of the same type of dwelling unit.

Some spaces were designed to accommodate specific groups. The changes in exterior walls show these distinctions in otherwise identical units.

the building is indeed a structuralist building, seeing that objects/spaces are not 'multi-interpretable' or flexibly usable. Still, the adherence to the grid, repetition of elements and influence of units to the connecting

Structuralisme: speelruimte en spelregels'.

To concretize our approach even further we limit our scope to genericity and specificity. And the coherency of the whole: mutual influence between the units and the connecting fabric.

5. floor height (con)



fig 27: Different floor heights.

Changes in floor height indicate the physical height of the child/user for whom the space was designed.

6. specific objects (con)



fig 28: Cooking unit.

Certain objects in the building were originally designed to accommodate a certain activity. To what extent they are prone to re-interpretation is debatable.

fabric and vice versa explains why a lot of features from this building inspired the structuralism movement. Or would lead people to identify this building as being an example of the structuralists movement.

Transformation and personal findings from the excursion

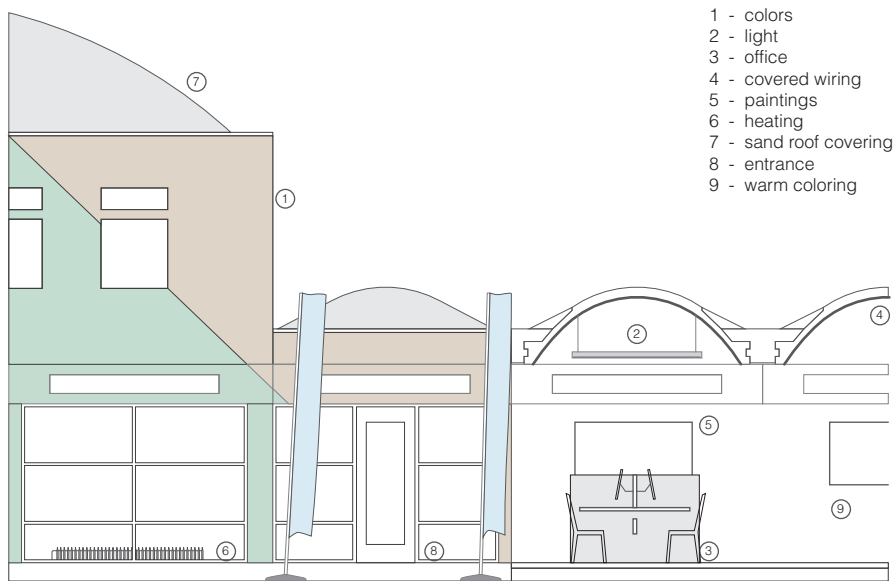

fig 29: Transformation diagram.

The transformation by Wessel de Jonge and Ex Interiors of the Burgerweeshuis resulted in a minimalist approach. The building qualities were mostly respected and restored. The green paint on the exterior walls was removed. Additional wiring was implemented underneath a paper glued layer on top of the concrete domes on the inside of the building. This helped the acoustics as well. The interior was mostly done by Ex-Interiors. She used color to create a very warm atmosphere and to specify the different rooms. Lighting in the building also accentuates the dwelling spaces and the aesthetics of the building structure.

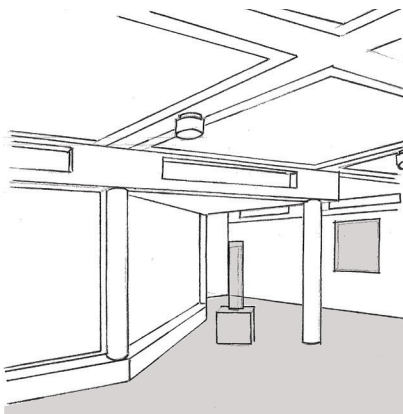

fig 30: Drawing of the hallway.

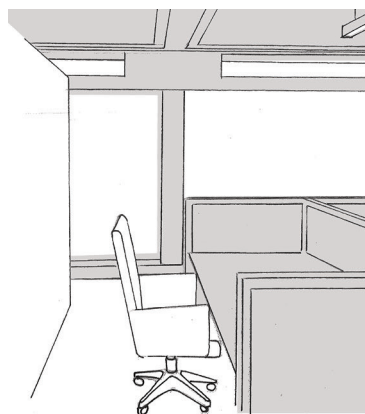

fig 31: Office relation to outside.

The hall causes initial disorientation because everything looks alike. The same elements are used everywhere throughout the building (columns, domes, architraves). Often it was uncertain in which area of the building we were.

The offices are stuffed with extra office furniture resulting in less openness. The view on the garden is obstructed by the elements used to define the office areas.

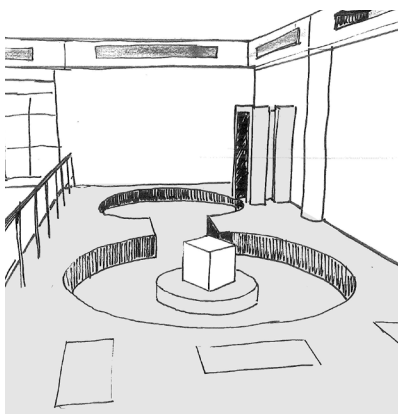

fig 32: Play quarters designed for the children.

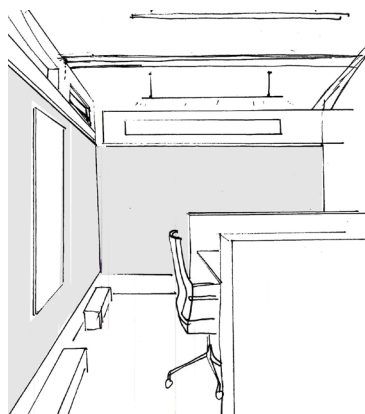

fig 33: Colors differentiate the office spaces.

The play areas that Aldo van Eyck had designed stayed exactly as they were. They are concrete molded to the floor. And thus hard to remove. There is no blockage to protect the play grounds, so it is possible to interact with them. The aim for the transformation architect was to use minimal intervention in the building in order to protect Aldo van Eyck's intended design. Furniture is used to enhance the spaces. Wall panels, art and a lot of statues are used to differentiate the office areas. This also helps with the wayfinding throughout the building.



4. 't Karregat (1973)

Architect: Frank van Klingeren

Location: Urkhovenseweg 16, Eindhoven

Group members: Michelle Betrman, Anne Ebbenhorst, Morsal Habib

The architect

Frank van Klingereren was born on February 4th 1919. He studied civil engineering and architecture, but never finished the later one. After working for several companies as a civil engineer, he started his own 'Studio for the Bouwtechniek' in 1948. Later he started doing more architectural projects, of which the Meerpaal in Dronten, the Agora Lelystad and 't Karregat in Eindhoven are his most well known works. These projects also express some of Van Klingereren's central themes:



fig 1. Frank van Klingereren

Declotting

In reaction to the modernists tendency to separate functions, a central theme in Van Klingereren's work was 'ontklontering' (declotting). By combining functions and removing boundaries new possibilities for meeting and public life arise.

Nuisance

Another theme in Van Klingereren's work is 'hinder' (nuisance). Declotting causes nuisance. This is usually considered as negative, but he turns it into something positive. Nuisance is contact and contact can lead to friendship or enmity or anything in between.

More with less and imperfection

More with less is not just about material in Van Klingereren's work. It is also about the program. By being less specific, more is possible. His engineering background was always subordinate to the architecture and social intentions. He also believed in imperfection and the unfinished. Comparably to the 'more with less', leaving things imperfect and unfinished creates possibilities for unexpected things to happen.

Art

Van Klingereren often collaborated with artist Pierre van Soest. Of all projects realized after 1953, Van Soest was involved with twothirds of them. The art gave the buildings a human touch, created more expressive buildings and was accesible to a large public.

TRIOLOGY

1965-67: de Meerpaal in Dronten
1966-72: Agora Lelystad

1970-73: 't Karregat in Eindhoven

fig 2. de Meerpaal in Dronten



fig 3. Agora Lelystad

1999: died at an age of 80 years old

1919: born

1928: CIAM founded

1939: working for Nederlandse
Dok Maatschappij (NDM)

1940: education concrete and steel

1944: living and working in houseboat
"de Witte Walvis"

1948: Studio voor Bouwtechniek

1953: Team 10 founded

1956: commision in Greece, contact with public life
in Greece inspiration for later 'agora' designs

1957: changed name to
'Architecten- eningenieursbureau Van Klingereren'
focus changed from engineering to architecture

1910

1920

1930

1940

1950

1960

1970

1980

1990

2000

- 1970: commission for shopping center
- 1971: first design inspired by Paul Klee
1971: start building Herzenbroeken
- 1973: 't Karregat in use
- 1974: first adjustments: parts of the school were walled off

- 1980
- 1981: renovation by Architektengroep Noord

- 1990
- 1989: second renovation by Passchier
"Most expensive living room in the Netherlands" (first 6 million, second 3,8 million)

- 2000
- 2010: Diederendirix and Architects En En win commission for renovation 't Karregat

- 2015: re-opening renovated Karregat

2020

Context

The neighborhood Herzenbroeken was built in the beginning of the 1970's in Eindhoven. The municipality wanted to create an alternative to the large-scale developments of the post war era. The new neighborhood should be experimental with new ideas about living and working with a strong social cohesion.

Herzenbroeken was situated in isolation from the center of Eindhoven and lay in between two railroads and a road. To accommodate the neighborhood, the municipality proposed a shopping center. Soon the idea arose to combine commercial and social functions in one building and in 1970 Frank van Klingeren was commissioned to make a design. The program of the building was extended to also include schools and a neighborhood center, but the budget was slim. The perfect commission for Van Klingeren and the beginning of 't Karregat.

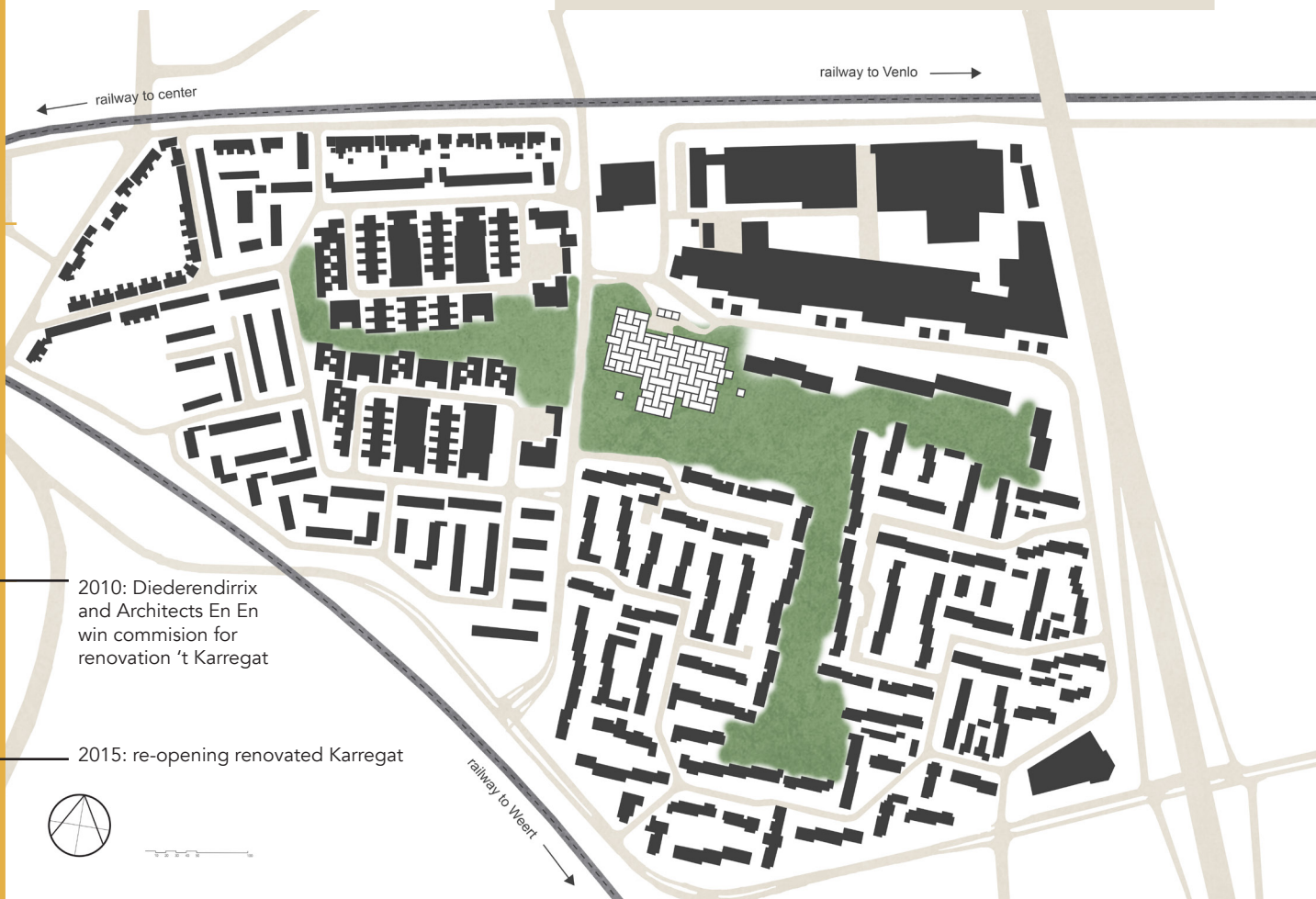

fig 4. 't Karregat and Herzenbroeken

Design Process

The project is commissioned by the municipality of Eindhoven and projectdevelopment agency AMRO-Westland/ Utrecht. The design started in 1970 and the constructed was finished in 1973.

When making the design of 't Karregat he got inspired by the painting of Paul Klee. He made almost an exact copy of this painting with his scale model which is depicted in the picture on the right. With this model in mind, he created the floorplan and added the functions.

The building takes its name from the area and its location. A Witkar was being used for the groceries. Due to the height differences in the building, the car would go to the lowest level. The children had to push the empty car back to the shop. This would also create a social interaction between the different age groups. Because of this idea, the building is called 't Karregat.

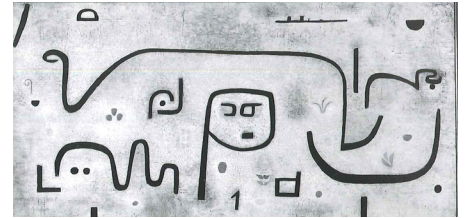

Fig 5. Frank van Klingereren got inspired by this painting of Paul Klee



Fig 6. Van Klingereren translated the painting of Paul Klee into a scale model

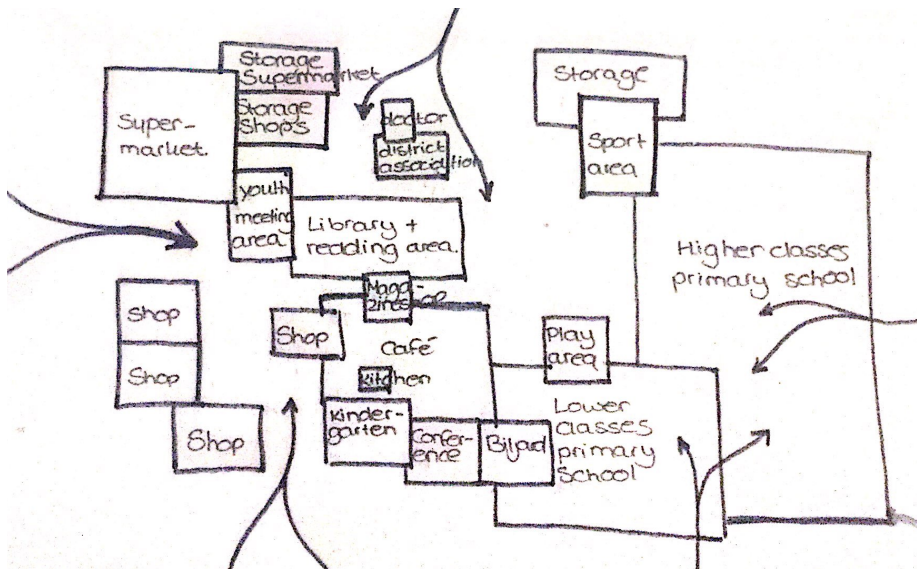

Fig 7. First scheme of functions

Startingpoints

His main startingpoint of this experimental project is to focus on the social events, or as he calls it: ontklontering.

Originally, the school wasn't in the program requirements but after adding this to the program of the building, Frank van Klingereren came up with the idea to accomodate education, culture and trade in one building. With this last addition the building started to function as the living room of the neighborhood.

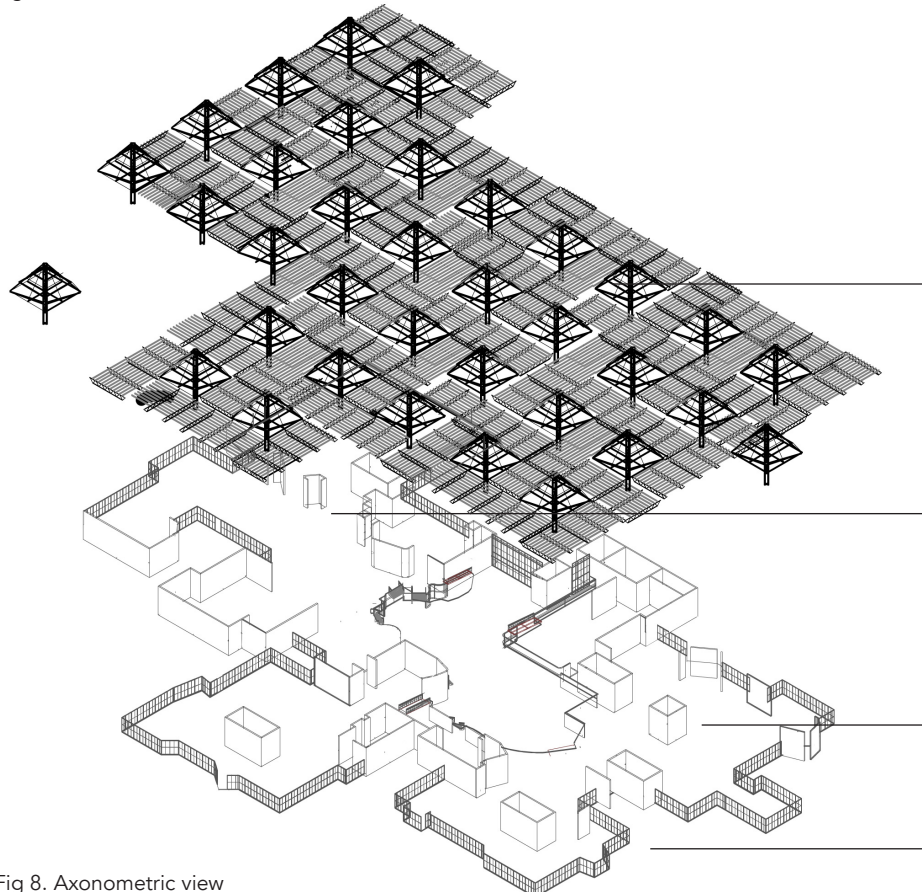

Fig 8. Axonometric view

Roof aesthetics were important because of the highrise building located next to it with people looking down on it.

Frank van Klingereren did not want walls to separate the different functions. He wanted the maximum openness of the space. This could let to a clash or confrontation.

Only the toilet units had their own fixed area.

Irregular shape of the façade.

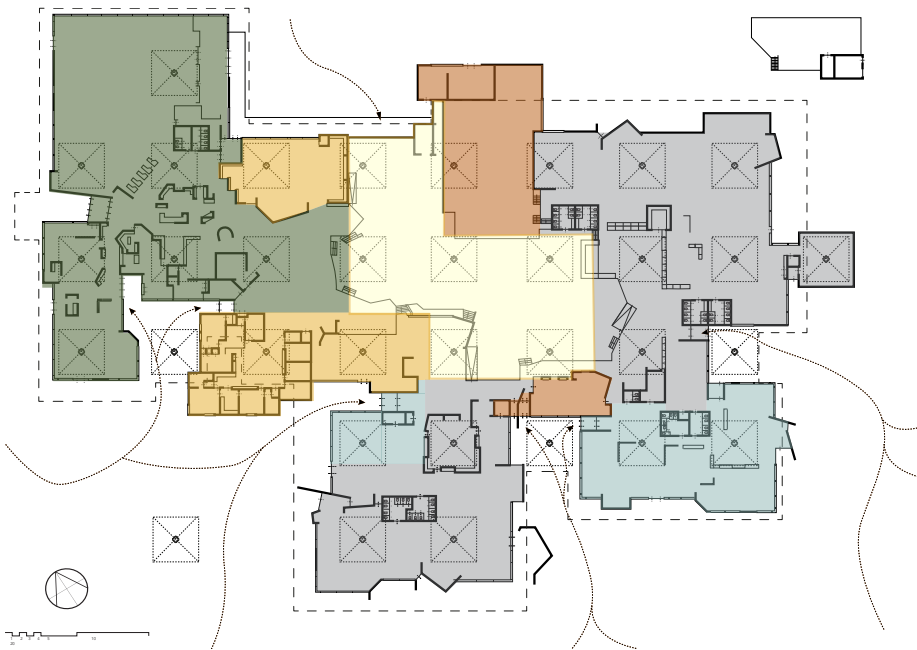

Fig 9. Floorplan 't Karregat (1973)

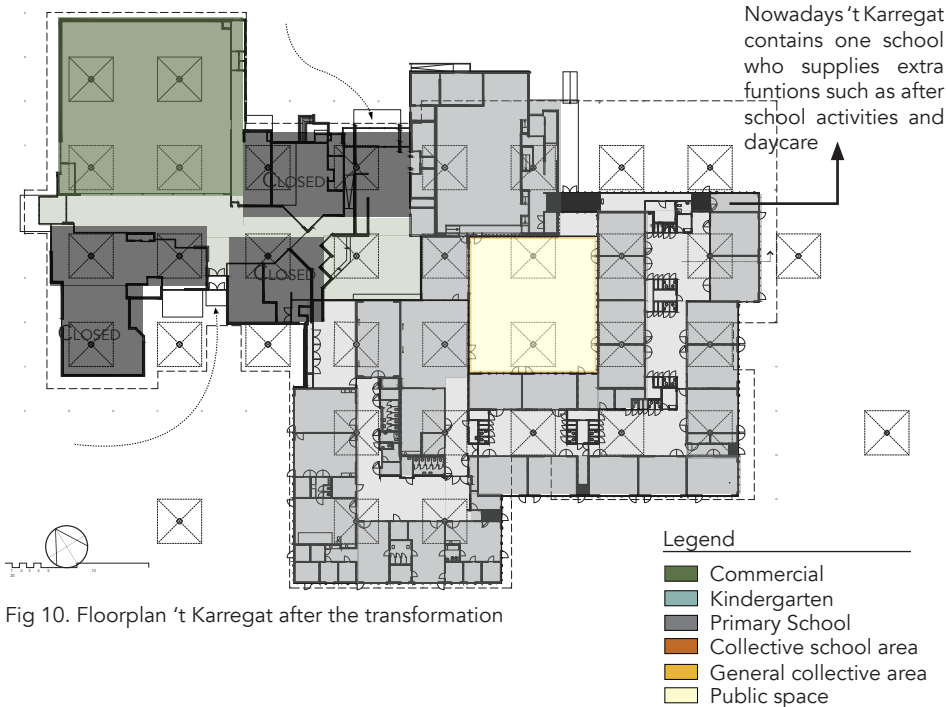

Fig 10. Floorplan 't Karregat after the transformation

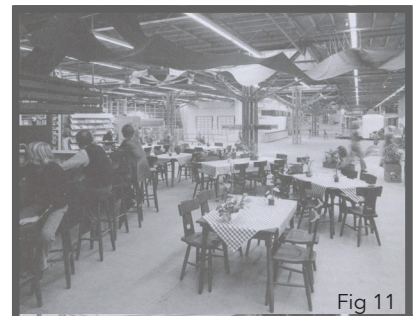

Fig 11



Fig 12



Fig 13



Fig 14



Fig 15



Fig 16



Fig 17

The transformation

The building is not a monument but is considered valuable by the municipality. This is partly due to the unique design by van Klingerer that responded to the demand for an experimental neighborhood center. It is considered as a design with an unique reflection of his time.

Diederendirix architecten (restoration background) and architecten en-en (school background) were the chosen architects to focus on this project. The first conclusion of their research was that the open space never worked and the needs of the neighborhood have changed. But the building is not made to divide it in seperate parts.

For the transformation they chose to restore the floor, roof and construction and make it sustainable. They brought back the original colour gradient of the collumns which was designed by Pierre van Soest. The new construction ensures decent spaces, corridors, transparency and still retains its spaciousness. By making the inner walls movable, the flexibility of the building is preserved, partly through the integration of sliding doors.

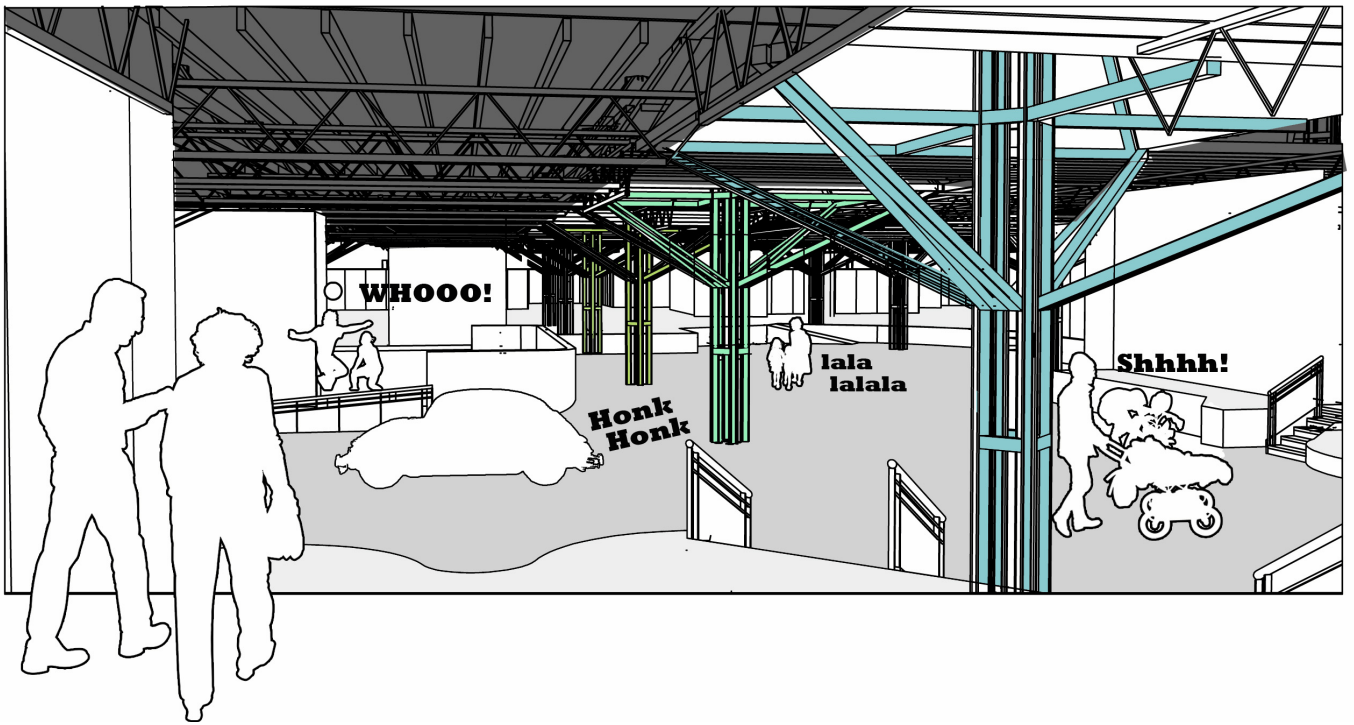

Fig 18. Perspective view of the interior

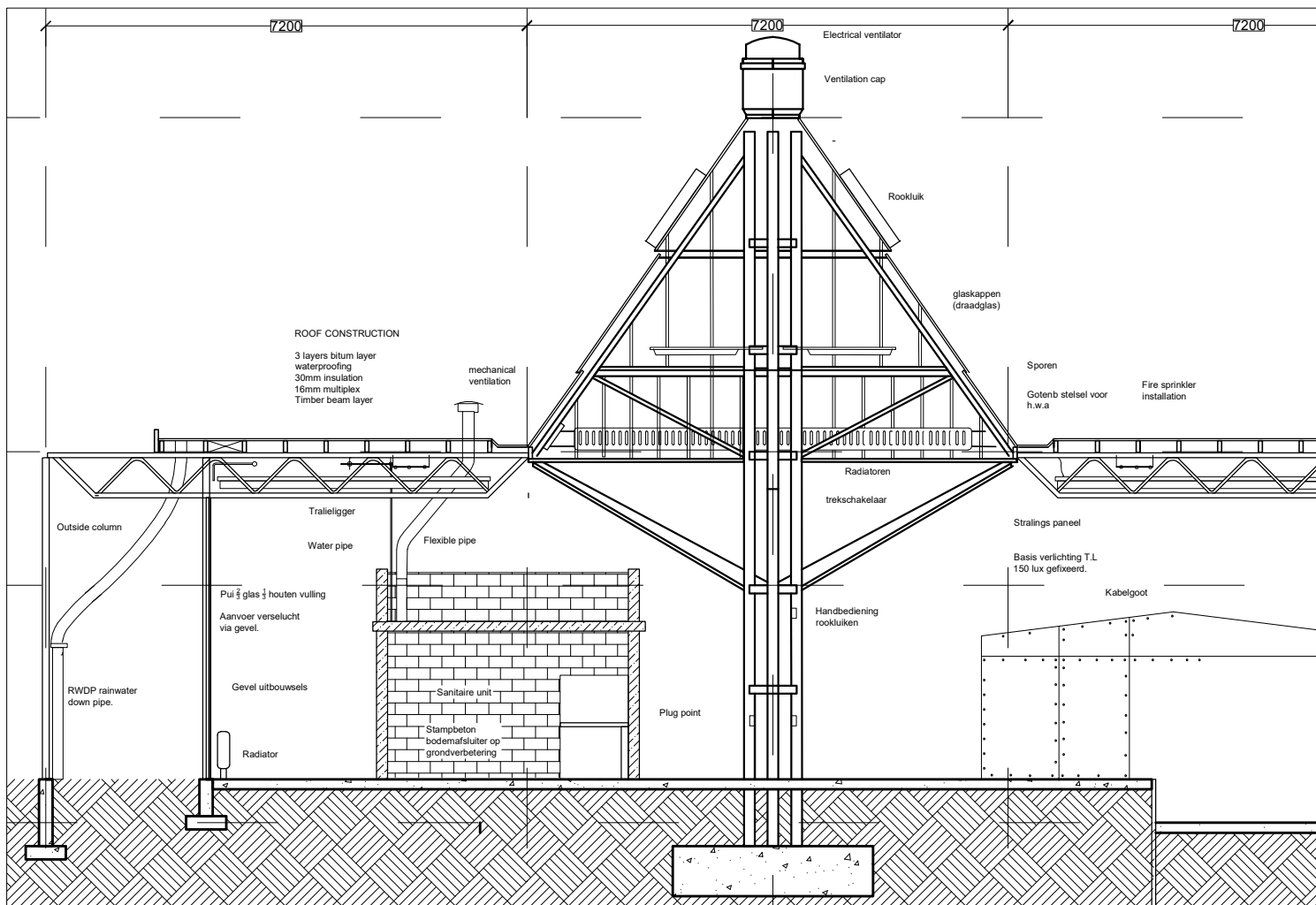

Fig 19. Scale 1:100 section.

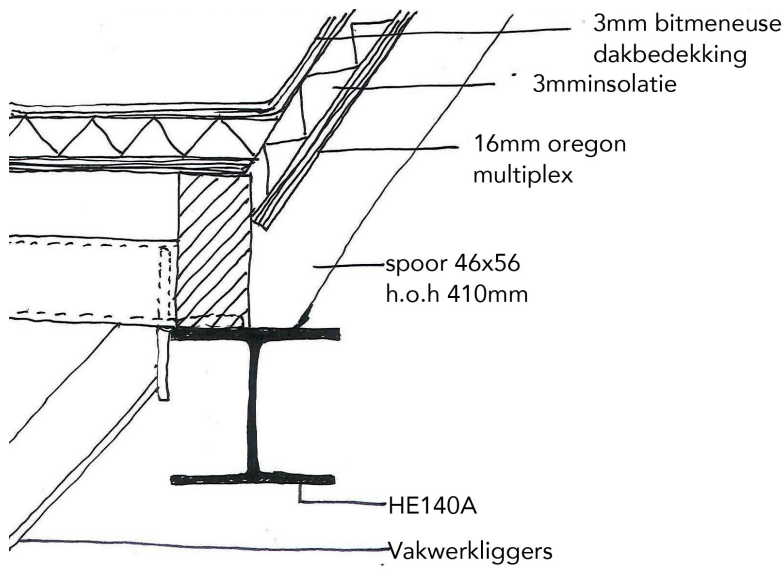

Fig 20. detail section

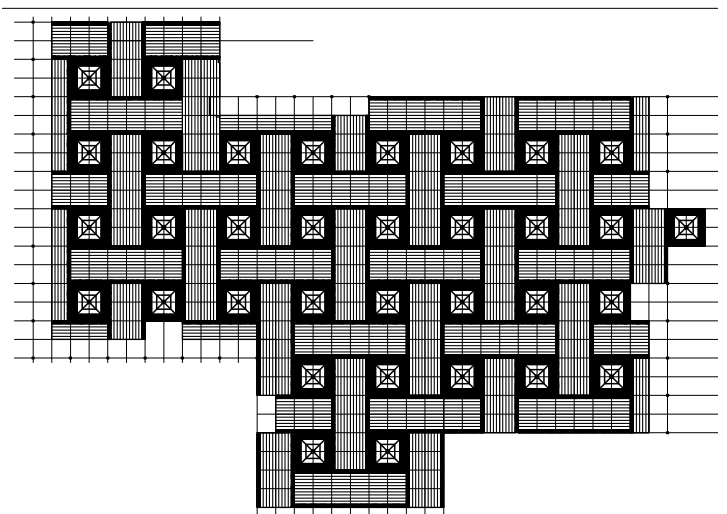
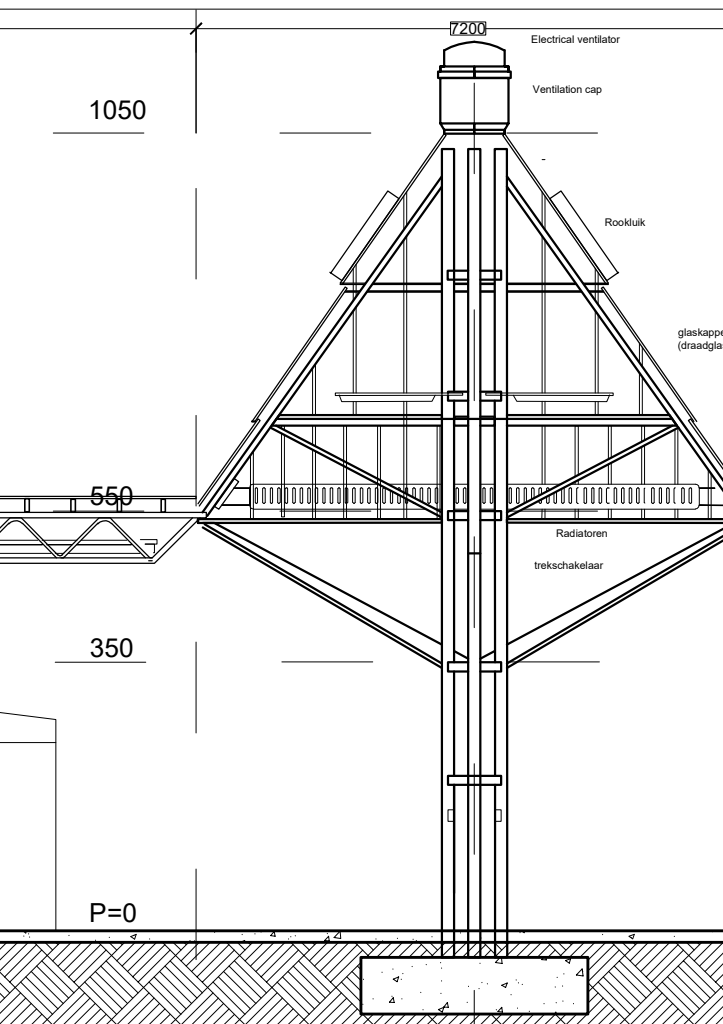

Fig 21. Roofplan drawing

Structure

Steel frame construction of umbrella like coumnes and steel joists inbetween. Structure is secured on a concrete pad foundations and timber joists carry the wooden waterproofed boarding for the roof. The infrustructure of the roof was seen as separate to the ground floor which is organic in form.

Services

The lightweight infrustructure of the roof houses all the services of the building which leaves the ground floor to have a max flexibility for layout changes.

REFLECTION What was the translation of the original design into the transformation?

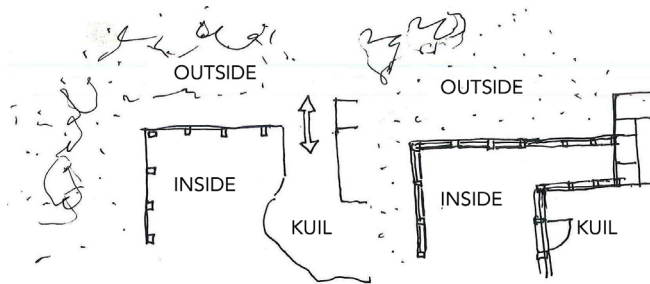

Original building

What aspects were successful:

1. large spans and high ceiling
2. daylight from above
3. the multifunctional building as living room of the new neighborhood created a strong sense of community
4. the use of art made the building more playful and it made the art available to a large public
5. good quality materials were used which have aged well

What aspects were problematic:

1. lack of climate control: ventilation, heating and cooling, dust
2. too open and not enough privacy for areas which need quiet, focused environments to function.
3. no acoustic insulation between different functional spaces for specific activities



fig. #. Living rooms inbetween classrooms as meeting space

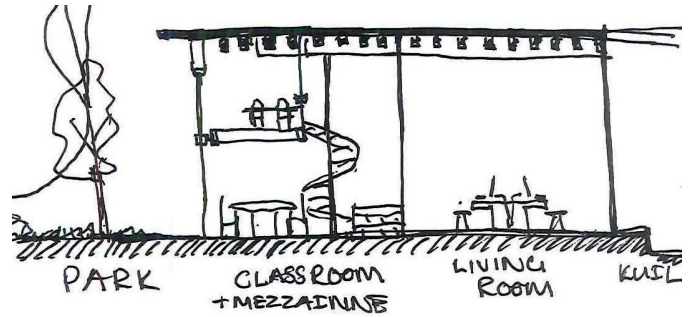

Transformed building

What aspects were successful:

1. use of a mezzanine level in certain classrooms to create more floorspace
2. the amount of daylight contributes to the users appreciation of the interior space
3. the living rooms in between the classrooms are a place for children, teachers and parents to meet
4. the original column color scheme was reintroduced
5. the "kuil" is well used by the school for celebrations

What aspects are not successful:

1. the relationship between inside and outside spaces is less emphasized
2. the "kuil" is no longer reachable by members in the neighbourhood
3. limited budget so cheaper materials were used which need to be replaced regularly

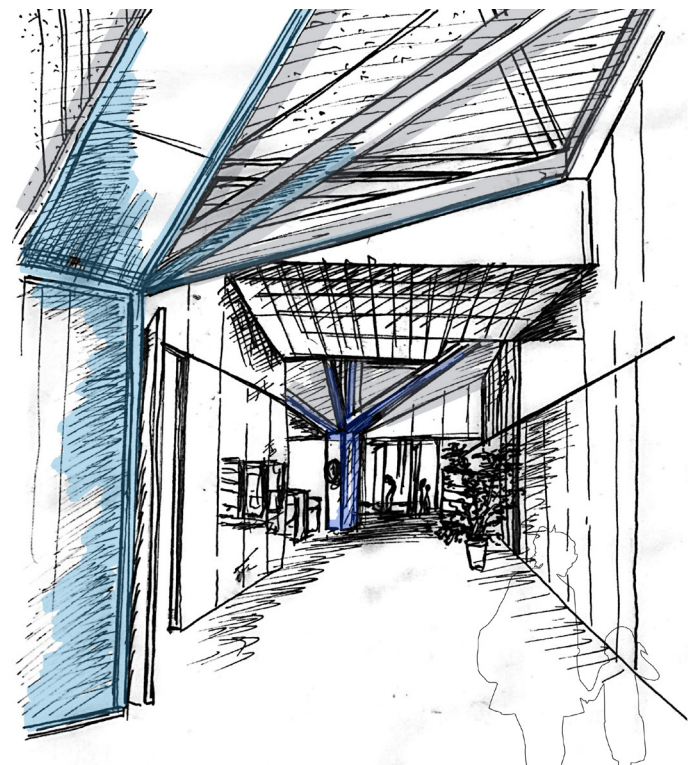

fig. #. Limited sightline along colored columns



5. Muziekcentrum Vredenburg (1978)

Architect: Herman Hertzberger

Location: Utrecht

Group members: Jeroen Bogaard, Jeroen Moerman, Josephine Uitrenbogert

Timeline Herman Hertzberger

What is structuralism for Hertzberger?

In his early years, after also attending lectures from Aldo van Eyck at the TU Delft, him and grand contemporary architects of the time like Le Corbusier formed a major inspiration for Hertzberger's first designs. He clearly uses the principles and building methods of the modern architecture movement, already aiming

for a more idealistic approach to architecture. In the age of congresses like CIAM Hertzberger, together with likeminded colleagues, joined magazine Forum less than a year after his studies, writing on his ideals and principles which he would later describe as the foundation for Structuralism as an architectural



1958:
Winning design for the student residence Weesperstraat. In this design everything came together: the influence of Le Corbusier and Aldo van Eyck. Examples are the accessible ground floor and the intergration from building in the city.

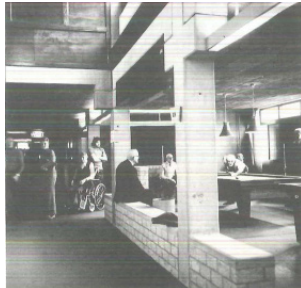

1964:
Drie hoven. A home for elderly where the social aspects of the project has been defining for the design. In his early design he used most of the time the same square construction.



1968:
Centraal Beheer. Workplace for 1000 people where everybody can order and decorate there own workplace. Away with the corridors! In this project the interaction between the different spaces are important.

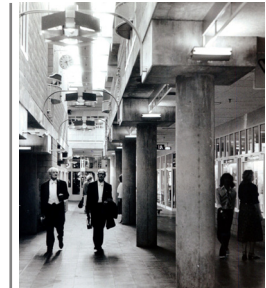

1973:
Music centre Vredenburg. Unlike the traditional form of a concert hall. No clear entrance but you will gradually come in. This is also the first project he used round columns.

MUSIC CENTER IS COMPLETED

BORN

Bouwkunde in Delft

FORUM - tijd

1932

1950

1958

1959

1963

1970

1979

Timeline development location and city

The castle was built under Spanish rule as oppression tool, but demolished quickly after independence.

CATTLE MARKET

In 1796 there was a private wooden theatre built on the location of Vredenburg. This building burned down in 1808 and had been rebuilt in 1821. In 1913 the theatre was no longer privately but became the city theatre.

1894:
Vredenburg get a trade function with the arrival of the Korenbeurs and the Fruithal.

The first trade fair was held at vredenburg in 1917, followed by the build of fixed buildings in 1921 called Jaarbeurs. In 1965 th trade fair moved tot the Croeselaan because the square of Vredenburg was to small. In 1970 the jaarbeurs buildings were demolished to make space for the shopping mall.

Jaarbeurs buildings

Catharijne convent

Castle Vredenburg

Theater

1100's

1528
1529

1577

1796

1921

1941

1970

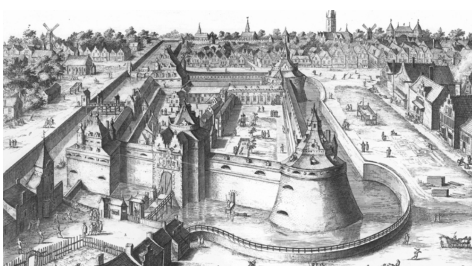

1954:
New plans for the center of Utrecht made by a traffic engineering. The big change was the coming of the Catharijnebaan on the place of the singel.

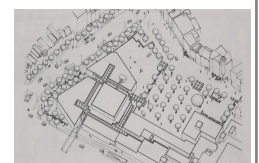

1973:
First plan of Vredenburg of Hertzberger. Here the large hall is straight.

movement. Hertzberger sees himself as an important instigator for this movement, being a driving force behind the social aspect of architecture so strongly implemented in its architecture. For Hertzberger this meant a focus on architecture designed from the interior, deprioritizing outer beauty of buildings, but also adapting to the contemporary thoughts and critiques on architecture. This change is important to him as later in his career he breaks with his old inspirators and tries to aim for an independent own architecture

bound to a more modern timeframe. In this he also criticizes his former professor Van Eyck when they jointly work on the transformation of his Burgerweeshuis and Eyck appears to be a stubborn conservative. Over his career Hertzberger sees his structuralistic buildings as transformable buildings that achieve a durability due to their adaptable nature, achieved with flexible column structures and humble designs. To him buildings are not a set object, but merely a set structure that facilitates an ever-changing group of users.



1979: Ministry of social affairs. Here you see a lot of similarity between Vredenburg. He used the same columns and steel railing.



1992: Chassé theater Breda. After Vredenburg Hertzberger started to design more theaters. In Breda you can see a transition phase from music centre Vredenburg to tivoli Vredenburg.

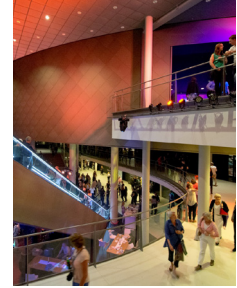

TRANSFORMATION VREDENBURG

Decane of berlage instituut

Write the books: Lessons in architecture about space

Independent: he gradully come loose of Le Corbusier and Aldo van Eyck

Teacher TU Delft

Own architectural firm

1985

1990

1995

1996

1999

2008

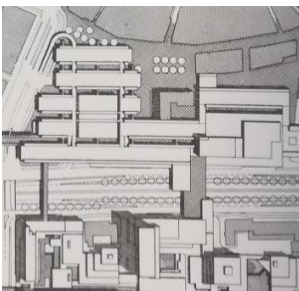

1969: First plan of the shopping mall Hoog Catherijne. In this plan the mall is also designed on the location of Vredenburg.

1993: Initial masterplan to better connect Utrecht city centre with the Jaarbeurs area with a broad approach to a homogenous large-scale project. It faced heavy opposition from the population.

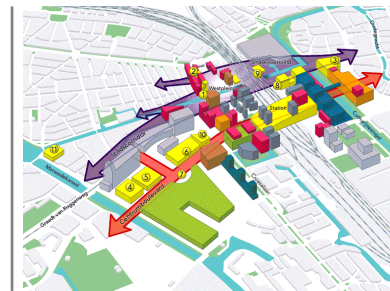

2002: Masterplan for the station area for 2030. The concept is to connect the old city to the jaarbeurs.

Winkelcentrum Hoge Catherijne



1979: The final design of the music center Vredenburg. Where the building and the square is one unit.

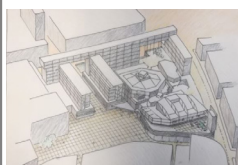

1995: Model study for a expansion of one hall to the existing Vredenburg.



2003: First plan of Herman for transformation Vredenburg

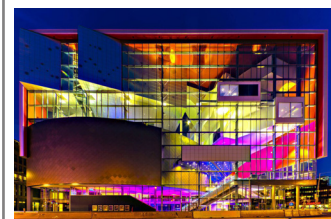

2008: The final design of Tivoli Vredenburg. Designed by 5 different architects.

Original design music center Vredenburg

What is structuralism for Vredenburg?

Apart from the characteristic build-up of repeated concrete elements in the facade the concept and layout of the building are not immediately apparent to be structuralistic. It does not consist of repeated boxes nor does it have a gridded layout of similar rooms. Yet as a concert hall is a quite specific building type the structuralism appears in a different scale and in different ways throughout the building. The plan-libre type construction of gridded elements is an essential part of the building as well as the humble materials used. Apart from curtains, acoustic wooden panels and the necessary wooden finish in the hall itself the building is entirely made up of cast-in-place concrete, concrete blocks and simple wooden and steel furniture. This was in line with the social equality so important in the structuralism movement. This equality plays a major role in the approach to the building's layout. Hertzberger compares his building a lot to the famous Opera Garnier in Paris and in sheer contrast to L'Opera's separation

of classes the symmetry and equality in spaces in Vredenburg facilitate a strong sense of togetherness in a hall where everybody has seats of the same quality and with the same view on the stage. Most importantly though is the sense of human scale Hertzberger shows. The building is a composition of small scale spaces and cozy nooks and corners, allowing for a grand array of intimate atmospheres, focused strongly on bringing people together. This is also achieved by the openness of the building through the use of a publicly accessible street with shops through the building and the possibility of opening the hall and entire building from all sides, creating a completely open space. This openness is in turn a connector of the city, bringing it inside and blurring the transition between inside and outside space, also integrating the composition of the square into building and urban fabric. Hertzberger ultimately sees this square as a permanently changing place that adapts in use and composition to a changing city and users.

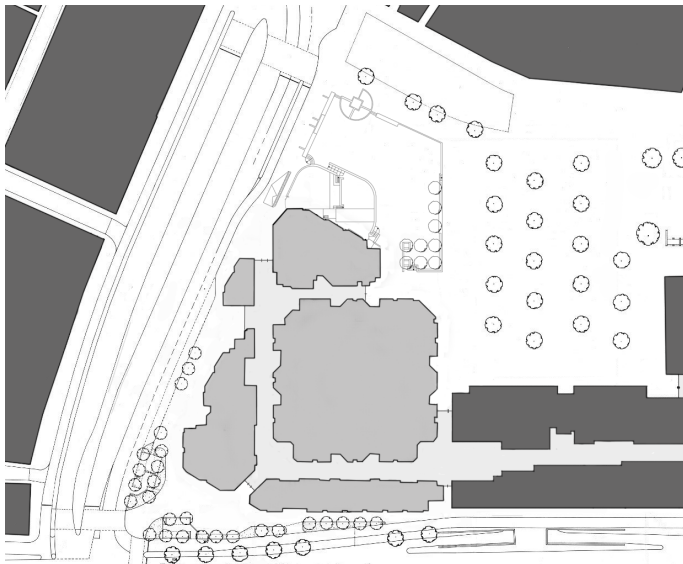

Figure 1: Situation of the music centre Vredenburg in 1979.

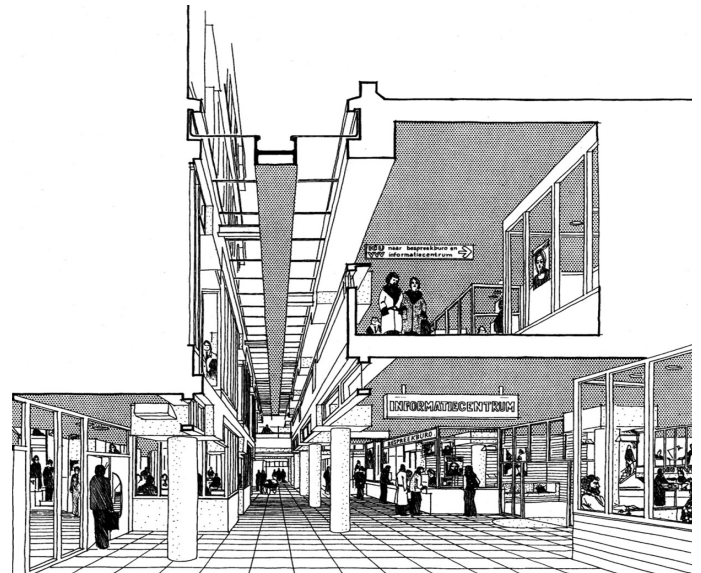

Figure 2: Passage of Vredenburg with the different spaces of the street.

Sight lines are an important aspect in the design of the old Vredenburg theater. They are used as part of the social interaction, and the connection between different spaces. This aspect has been implemented throughout the building, often creating connections between vertical spaces. Examples of these are the upper and lower floor of the passageway, and the openings in the

staircases within the foyer. The need for a good view of the performance area was a key point in Hertzberger's design of the theater hall. Being of the notion that a good view is complementary to the auditory experience. For this reason Hertzberger designed the seating areas in such a way that everyone would have an unobstructed view of the performance area.

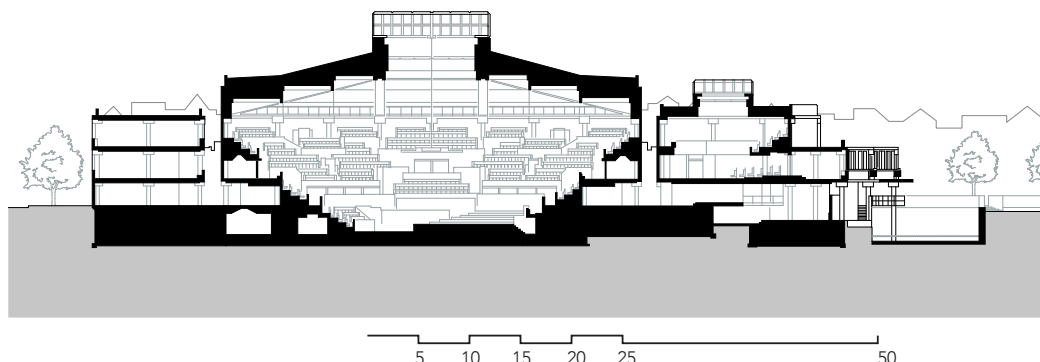

Figure 3: Section of the music centre.

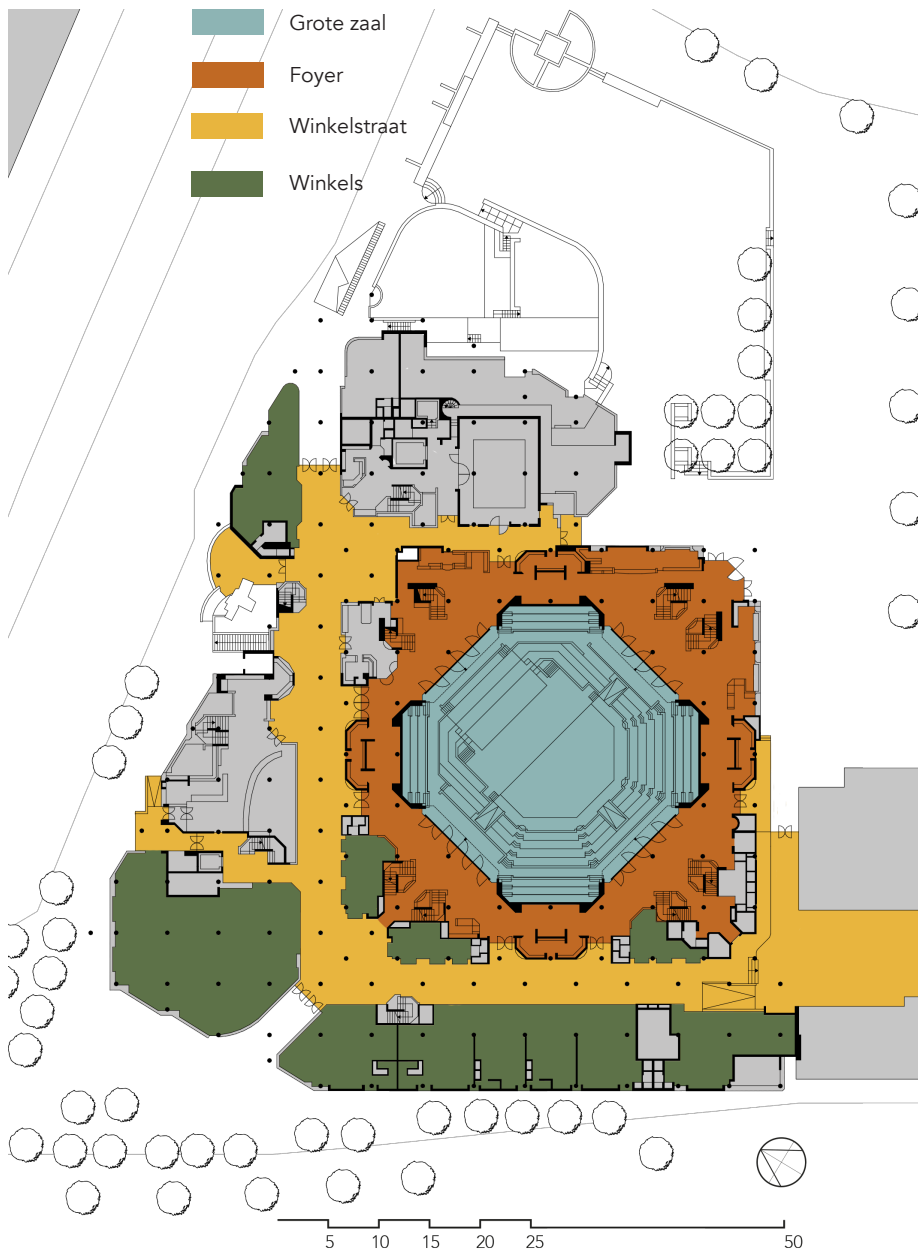

Figure 4: Floorplan of the ground floor with function indication.

Functions

Central in the old floorplan of Vredenburg lies the eight-sided theater hall. The foyer that surrounds it is a conglomerate of small, and each very different spaces. Ranging from highly introvert and drawn back spaces to areas with large amounts of overview and opportunities for social interaction. Spread out over the foyer are many buffets which results in a balanced dispersion of the audience. The small scaled spaces are complimented by the over 25 entrances to the theater hall, and the 8 staircases, that together allow for a well-organized flow of visitors. Enclosing the theater on nearly every side is an indoor passageway that allows entrance to the theater, but also to the stores, offices, and information center. The passageway was designed like a street, with the key points in the design being the vertical aspect, the light from above, and street like materials (mainly concrete). The theater had many entrances into the passageway that made it possible to create an open and smooth transition between these two spaces. This open structure was very effective for the free concerts that were held.

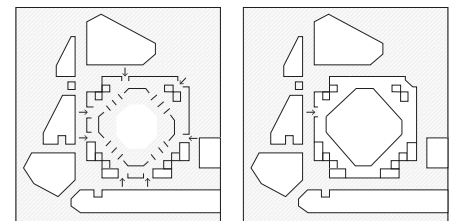

Figure 5: Open and closed diagram

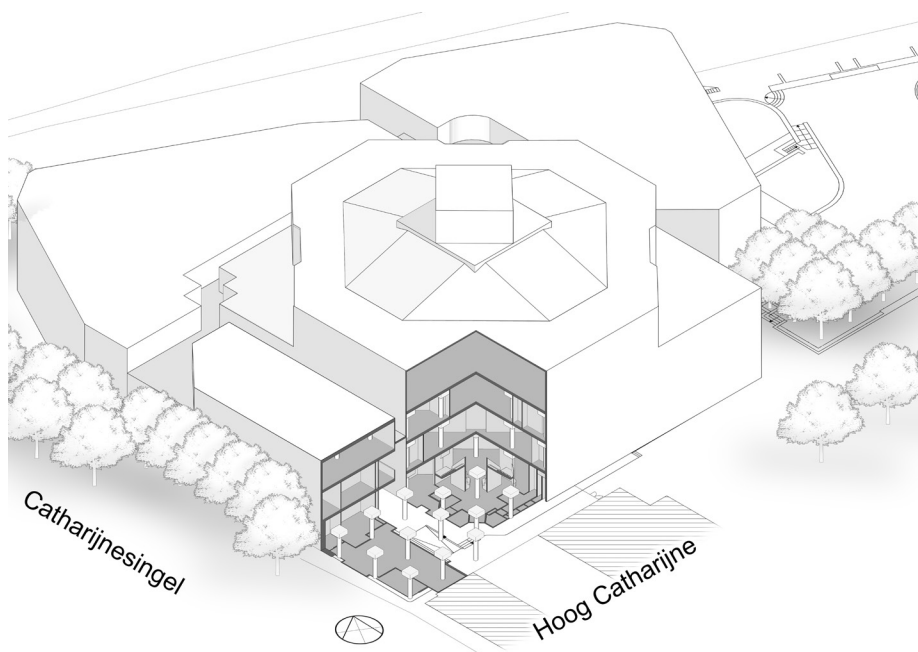

Figure 6: Axonometric of the music centre Vredenburg.

For the regular performances the organization found it easier to use one entrance, this meant that it took longer for the visitors to spread out over the different spaces of the foyer. Hertzberger himself later reflected that our current day concert practices call for a single main entrance.

The different volumes that make up the building are connected through an indoor passageway. Although the volume of the building doesn't insinuate a grid structure there clearly is one, as revealed in the axonometric view. The grid structure is used in a plan libre type fashion, creating a free layout of the floorplan. This made it possible for Hertzberger to design many different spaces, with each their own spatial qualities.

Construction and layers

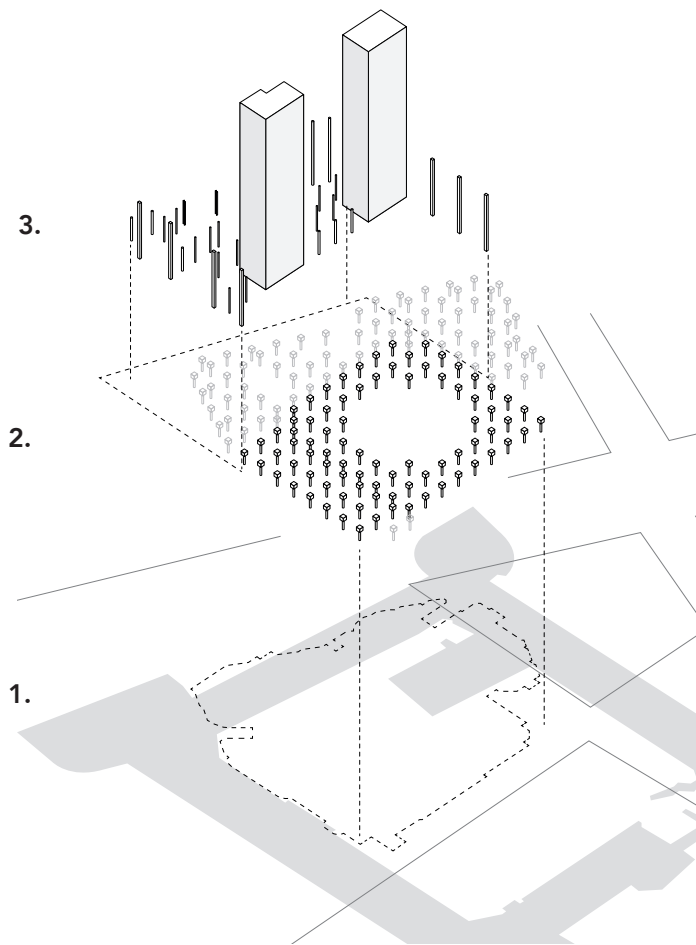

Figure 7: Construction model of the different layers of the location.

An important part of the atmosphere and structure in the building is created through the use of very distinctive round columns with broad square heads. Hertzberger explains the use of these for guiding people around the columns with their roundness and using the heads for a large variety in structural uses, granting the

opportunity to vary with ceiling heights, wall indents and spacing, and allowing for a larger span of floors with more space in between the individual columns, largely in contrast to the beam-supporting square columns of earlier designs. The incentive for this change might have been the possibility for a square grid with more flexibility and the possibility of spanning floors in both directions wherever necessary. Hertzberger shows in his design process a careful exploration of the different connecting points between these repeating columns and differing wall-, ceiling-, and window sill compositions. As well Hertzberger created a variation of three different ceiling heights with which floors with the same column heights get different atmospheres and transitions between lower and higher rooms are partitioned by characteristic stepped ceiling frames. By knitting the outer facade around the columns in different ways in different positions and placing the column grid in line of logistical elements like entrances and hallways the repeated columns form an essential part of the building. Though this (dis)placement of columns - compared to conservative designs - does create strange occurrences where columns are right after and in the middle of doors, cut through the main street, forming a section between the two sides, and most of all form an almost disastrous penalty to the insulation and climatization of the building wherever they appear within an outer facade and form a concrete thermal bridge from outside to inside. With the new construction of the transformation (3) being a contrasting modern way of building and parts of the old castle (1) still present underneath and old Vredenburg's characteristic column structure (2) in between, the whole can be seen as a timeline between different ways of construction to achieve different goals. All in all the columns form an intrinsic part of the structuralism in the building, showing the wide range of characteristic possibilities with repeated standard elements and a strong representer of its contemporary architecture.

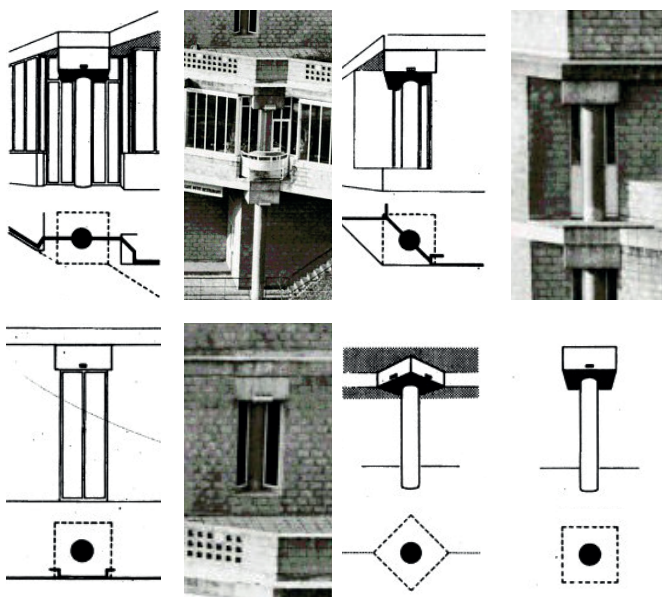

Figure 8: Study to the different column connections.

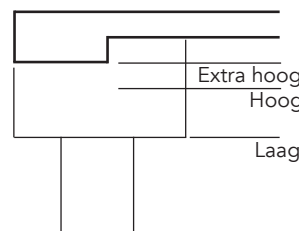

Figure 9: Different ceiling heights used in the building.

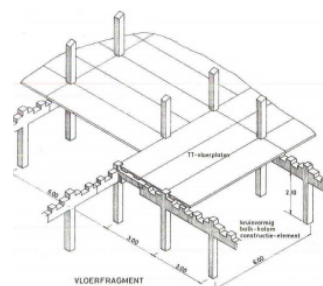

Figure 10: Initial construction concept used in early designs.

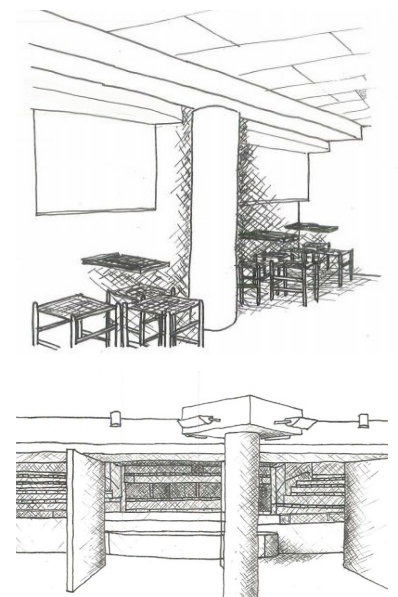
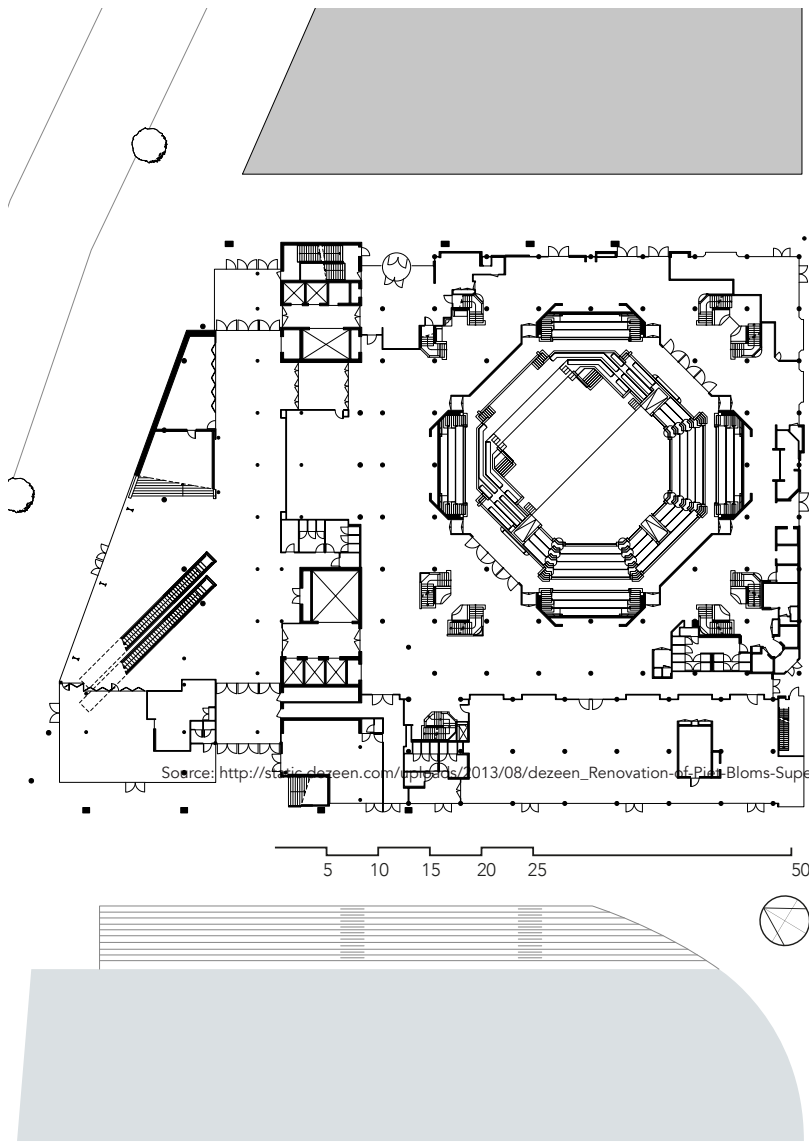

Figure 11a&b: Sketch of different spaces

Transformation to Tivoli Vredenburg



Source: http://stijl.dezeen.com/projects/2013/08/dezeen_Renovation-of-Piil-Bloms-Supercube-by-Personal-Architecture-2013/

The transformation of the building took place for several reasons. The old Vredenburg had its problems - empty shops, abandoned and dangerous inside/outside street in the building, climate problems, and a non-working concept of openness - but the main reason was the renewal of the central station urban area to modernize the city, which included a centralization of the music centres in the city. For the transformation 4 different parties, including Hertzberger for the old hall, worked together, soon creating the concept of a building as a city wherein every hall had its own design, materialization and identity and was built as an individual block within a simple joined construction. After different design ideas for the whole the new part has nothing to do with the structuralism of the old building and is in large sense more a reflection of the architectural cooperation and identity than a homogeneous representation of ideals. It stands almost disconnectedly away from the old part, only connected through the ground floor lobbies. Although the interior spaces still own a cozy atmosphere and leveling characteristic to Hertzberger's designs it has completely broken with almost every original structuralistic concept of the old Vredenburg.

Figure 12: Floorplan of the groundfloor of the music palace Tivoli Vredenburg.

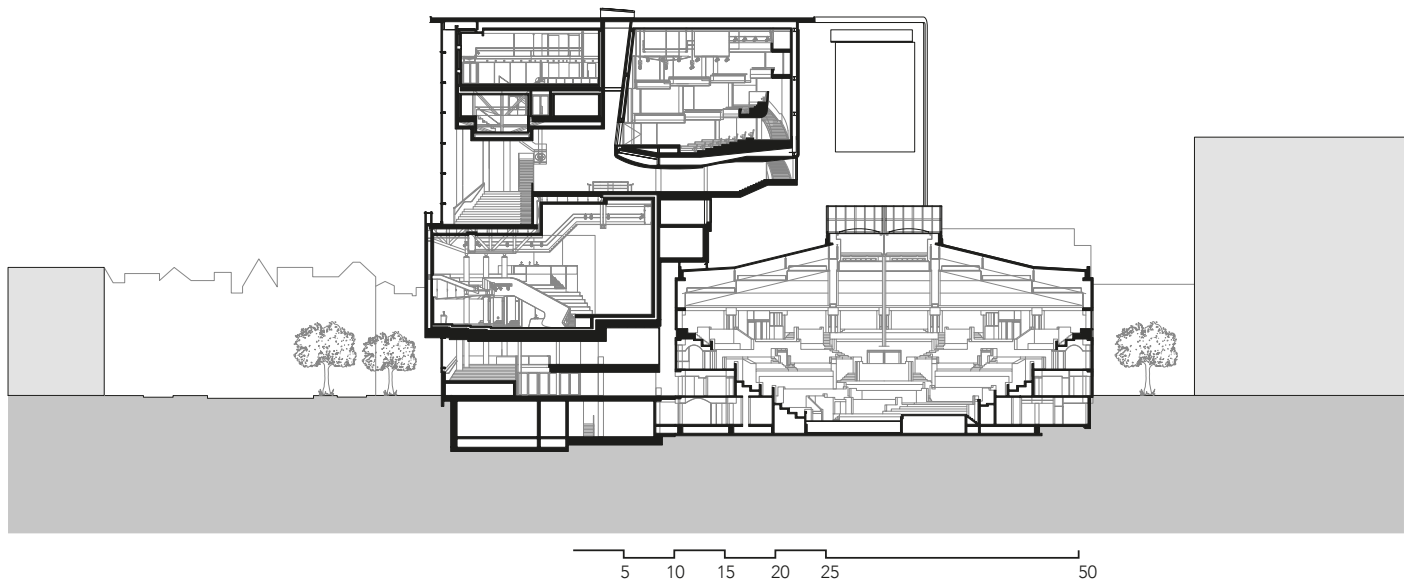

Figure 13: Section of the music palace Tivoli Vredenburg.

Blaakse Bos

Image sources:

fig 1: own illustration

images used in collage

http://www.architectuur.org/nieuwsitem/398/Recensie_Piet_Blom.html

http://elzendaalarchitectuur.wikia.com/wiki/File:Piet_blom.jpg

<http://fotos.secc.nl/zuid-holland/rotterdam/rotterdam-11349/>

<http://fotos.secc.nl/zuid-holland/rotterdam/rotterdam-53670/>

<http://mapio.net/pic/p-34242747/>

[http://www.oud-rotterdam.nl/foto%20\(307\).jpg](http://www.oud-rotterdam.nl/foto%20(307).jpg)

https://en.wikipedia.org/wiki/Carpet_bombing#/media/File:Rotterdam,_Laurenskerk,_na_bombardement_van_mei_1940.jpg

<https://i1.wp.com/groot-driene.nl/wp-content/uploads/2015/06/kasbah.jpeg?w=348>

<http://images.memorix.nl/rce/thumb/800x800/92cfbea8-2568-245e-a1e7-60951f7a84c7.jpg>

https://upload.wikimedia.org/wikipedia/commons/3/3b/Overzicht_ingangspartij_van_het_theater%2C_ontworpen_door_Piet_Blom_-_Helmond_-_20536874_-_RCE.jpg

https://upload.wikimedia.org/wikipedia/commons/thumb/9/9a/Rotterdam_Cube_House_street_view.jpg/640px-Rotterdam_Cube_House_street_view.jpg

https://media.abitaz.com/prd/photos/hb5/hb7/8818989072414/0078492Media_photo-large

<http://www.architectuur-fotograaf.eu/wordpress/wp-content/uploads/G8N51118-b.jpg>

<http://www.architectuur-fotograaf.eu/wordpress/wp-content/uploads/G8N51118-b.jpg>

<http://gerdienvandergaaff.nl/wp-content/uploads/Blomlezing.pdf>

fig 2: Drawings Piet Blom, HNI archive BLOM_144-2

fig 3: Drawings Piet Blom, HNI archive BLOM_234-3

fig 4: Drawings Piet Blom, HNI archive

fig 5: Drawings Piet Blom, HNI archive

fig 6: Drawings Piet Blom, HNI archive

fig 7: Own illustration

fig 8: Drawings Piet Blom, HNI (BLOM_234-12) edited by Lydia de Vries

fig 9: Drawings Piet Blom, HNI (BLOM_234-12) edited by Lydia de Vries

fig 10: Own illustration

fig 11: Drawings Piet Blom, HNI (BLOM_92-1) edited by Lydia de Vries

fig 12: Personal Architecture: http://static.dezeen.com/uploads/2013/08/dezeen_Renovation-of-Piet-Bloms-Supercube-by-Personal-Architecture_20.gif

Bibliography:

Hengeveld, J. (2008). *Piet Blom*, Jaap Hengeveld publications. Amersfoort.

Websites used:

<http://www.pietblommuseum.nl/piet-blom/biografie/>

<https://www.architectuur.nl/nieuws/renovatie-kubuswoningen-piet-blom/>

<http://gerdienvandergaaff.nl/wp-content/uploads/Blomlezing.pdf>

<https://www.personal-architecture.nl/superkubus/>

Ter Aar

Image sources:

- Fig 1 :Picture of Joop van Stigt's family, De Architect, 1982. Joop van Stigt. De Architect, special Hout.
- Fig 2: Site picture of Raadhuis, Ter Aar, Downloaded from Beeldbank Cultuur Historische Vereniging Ter Aar. Web.
- Fig 3 :Site picture of Raadhuis, Ter Aar, Downloaded from Beeldbank Cultuur Historische Vereniging Ter Aar. Web.
- Fig 4 : Abstraction plan of the building, scanned from Het Nieuwe Instituut archive. 1965
- Fig 5 : References Plan and section of Villa La Rotonda. Online: Wikipedia, Villa Capra "La Rotonda".
;Plan and section of Bathhouse. Online: Archtgames, Five cardinal points of bath house by Louis Kahn
;Plan and section of Amsterdam Orphanage. Online: Archdaily, AD Classics.
- Fig 6 : Concept diagram drawn by Marjan
- Fig 7: Diagram of the plan, drawn by Marjan
- Fig 8: Interior photo, De Architect, 1982. Joop van Stigt. De Architect, special Hout.
- Fig 9: Interior photo, De Architect, 1982. Joop van Stigt. De Architect, special Hout.
- Fig 10: Interior photo, De Architect, 1982. Joop van Stigt. De Architect, special Hout.
- Fig 11: Diagram of the section, drawn by Marjan
- Fig 12: Atrium of the Raadhuis, Ter Aar, Photo by Feng
- Fig 13: Facade of the Raadhuis, Ter Aar, Photo by Feng
- Fig 14: Plan of the Raadhuis, 1965. Scanned from Het Nieuwe Instituut archive.
- Fig 15: Sketches for addition
- Fig 16: Plan of the Raadhuis, 1991. Scanned from Het Nieuwe Instituut archive.
- Fig 17: Current plan of the Raadhuis, Photo by Feng.
- Fig 18: 30 Paper drawing of the Raadhuis,1991, scanned from Het Nieuwe Instituut archive.

Bibliography:

- De Architect, 1982. Joop van Stigt. De Architect, special Hout, p. 45.
- GevelRaad, 1999. Isoleer dak en fundering zwaar en de karakteristieke gevel licht. Gevel Raad, Volume 14, p. 8.
- Steenhuis, M., 2014. Joop van Stigt, architect. Amsterdam: Stichting Dogon Onderwijs .

Burgerweeshuis

Image sources:

Fig1: <https://goric.com/designer-profile-aldo-van-eyck-playground-every-neighborhood/>

Fig2: <https://merijnoudenampsen.org/2013/03/27/aldo-van-eyck-and-the-city-as-playground/>

Fig3: Own illustration

Fig4: <https://thesleepofrigour.wordpress.com/2013/01/06/the-orphanage-amsterdam-1960-aldo-van-eyck/>

Fig5: http://www.suzannefischer.nl/wp-content/uploads/2016/07/45_Burgerweeshuis.jpg

Fig6: Own illustration.

images used in collage:

<http://architectuur.com/architect/aldo-van-eyck>

<https://merijnoudenampsen.org/2013/03/27/aldo-van-eyck-and-the-city-as-playground/>

<http://www.alvisvastgoed.nl/projecten/burgerweeshuis.html>

https://nl.wikipedia.org/wiki/Herman_Hertzberger

<https://www.architectuur.nl/nieuws/expositie-rijk-aan-ontwerpkracht/>

<https://www.lensvelt.nl/wp-content/uploads/2018/01/Ex-Interiors-Lensvelt-BPD-Burgerweeshuis-Amsterdam-Aldo-van-Eyck-Boring-Collection-Norr11-Nestor-Nestor-en-Rotsen.jpg>

<https://www.lensvelt.nl/wp-content/uploads/2018/01/Ex-Interiors-Lensvelt-BPD-Burgerweeshuis-Amsterdam-Aldo-van-Eyck-Boring-Collection-5.jpg>

Fig7: <http://dearchitect.nl.s3-eu-central-1.amazonaws.com/app/uploads/2018/01/BPD-BWH-foto-Corn%C3%A9-Bastiaansen-3187-e1517258396820-683x1024.jpg>

Fig8: <http://www.hoogaerts.nl/Projecten/Project/burgerweeshuis-amsterdam>

Fig9: https://architectenweb.nl/media/illustrations/2018/02/764b9604-e3dd-4e22-8cec-1186bd065b0b_400.jpg

Fig10: <http://www.hoogaerts.nl/Projecten/Project/burgerweeshuis-amsterdam>

Fig11: Own illustration based on *Transformatiekader Burgerweeshuis - Wessel de Jonge Architecten*.

Fig12: Own illustration

Fig13: p92 - Ligtelijn, V., *Aldo van Eyck - Werken*, 1999

Fig14: Own illustration based on scheme p92 - Ligtelijn, V., *Aldo van Eyck - Werken*, 1999

Fig15: Own illustration based on *Burgerweeshuis Plans* by van Eyck. Nieuw Instituut Archief - nr.

Fig16: Own illustration based on *Burgerweeshuis Plans* by van Eyck. Nieuw Instituut Archief - nr.

Fig17: Own illustration

Fig18: www.gensvastgoed.nl

Fig19: Own illustration based on Ligtelijn, V., *Aldo van Eyck - Werken*, 1999. p. 98 -107

Fig 20: Own illustration based on Ligtelijn, V., *Aldo van Eyck - Werken*, 1999. p. 98 -107

Fig21: Own illustration based on Ligtelijn, V., *Aldo van Eyck - Werken*, 1999. p. 107

Fig22: edit of Strauven, F., *Het Burgerweeshuis van Aldo van Eyck - een modern monument*, Amsterdam 1987. p. 20

Fig23: <https://www.lensvelt.nl/wp-content/uploads/2018/01/Ex-Interiors-Lensvelt-Burgerweeshuis-Amsterdam-Aldo-van-Eyck-Boring-Collection-3.jpg>

Fig24: *Quadrat, Burgerweeshuis Amsterdam Transformatiekader Buitenruimte*, 2016. p. 18

Fig25: Ligtelijn, V., *Aldo van Eyck - Werken*, 1999. p. 109

Fig26: Ligtelijn, V., *Aldo van Eyck - Werken*, 1999. p. 104

Fig27: *Quadrat, Burgerweeshuis Amsterdam Transformatiekader Buitenruimte*, 2016. p. 13

Fig28: https://architectenweb.nl/media/illustrations/2018/02/332cac8d-78b0-414c-aa74-c9fca8fb7f50_400.jpg

Fig29: <https://020apps.nl/wederopbouw/IJsbaanpad/Burgerweeshuis>

Fig30: Jonge, W. de, *Transformatiekader - W411 Burgerweeshuis Amsterdam*, 2016. p. 34

Fig31: Ligtelijn, V., *Aldo van Eyck - Werken*, 1999. p. 103

Fig32: Ligtelijn, V., *Aldo van Eyck - Werken*, 1999. p. 103

Fig33: Ligtelijn, V., *Aldo van Eyck - Werken*, 1999. p. 107

Fig34: Ligtelijn, V., *Aldo van Eyck - Werken*, 1999. p. 107

Bibliography:

Graaf, K. de, Lucas, E. 'BPD naar Amsterdam'. *BPD magazine*. nr.06 (2017). pp42-53.

Jonge, W. de, *Transformatiekader - W411 Burgerweeshuis Amsterdam*, 2016

Ligtelijn, V., *Aldo van Eyck - Werken*, 1999

Strauven, F., *Het Burgerweeshuis van Aldo van Eyck - een modern monument*, Amsterdam 1987

Strauven, F., *Aldo van Eyck - The Shape of Relativity*, Amsterdam 1998

Websites used:

<https://www.archdaily.com/151566/ad-classics-amsterdam-orphanage-aldo-van-eyck>

<http://www.dearchitect.nl/architectuur/blog/2014/09/kenneth-frampton-over-structuralisme-orde-en-chaos-101112928>

't Karregat

Image sources

Figure 1. van Den Bergen, M., & Vollaard, P. (2003). Hinder en ontklontering: architectuur en maatschappij in het werk van Frank van Klingeren. Uitgeverij 010, p 2.

Figure 2. van Den Bergen, M., & Vollaard, P. (2003). Hinder en ontklontering: architectuur en maatschappij in het werk van Frank van Klingeren. Uitgeverij 010, p 106.

Figure 3. van Den Bergen, M., & Vollaard, P. (2003). Hinder en ontklontering: architectuur en maatschappij in het werk van Frank van Klingeren. Uitgeverij 010, p 167.

Figure 4. produced by Anne Ebbenhorst. Based on: Zwet, C.J. van der (1974). Wijkcentrum 't Karregat Eindhoven. Bouwkunde TH Delft, p 15.

Figure 5. Paul Klee, Insula Ducamara. Gekleurd stijfjel en olieever op krantpapier (1938)

Figure 6. Bouwmethodiek, wijkcentrum 't Karregat (1974)

Figure 7. Own illustration

Figure 8. Own illustration

Figure 9. Bewerking van "bouwmethodiek, wijkcentrum 't karregat (1974)"

Figure 10. Bewerking van "Karregat Eindhoven diederendirrix architecten & architecten | en | en"

Figure 11. van den Bergen, M. , Vollaard, P. OASE W57/2001. 't Karregat

Figure 12. van den Bergen, M. , Vollaard, P. OASE W57/2001. 't Karregat

Figure 13. van den Bergen, M. , Vollaard, P. OASE W57/2001. 't Karregat

Figure 14. Het Nieuwe Instituut, archieve material (1973), Unknown

Figure 15. Bewerking van "Karregat Eindhoven diederendirrix architecten & architectenlenlen"

Figure 16. Bewerking van "Karregat Eindhoven diederendirrix architecten & architectenlenlen"

Figure 17. Bewerking van "Karregat Eindhoven diederendirrix architecten & architectenlenlen"

Figure 18. Perspective view of the interior. Produced by Michelle Bettman (2018)

Figure 19: Axonometric view. Produced by Michelle Bettman (2018)

Figure 19: Section 1:100. Produced by Michelle Bettman (2018) Based on Zwet, C.J. van der (1974). Wijkcentrum 't Karregat Eindhoven. Bouwkunde TH Delft, p2_20

Figure 20: Own drawing

Figure 21: Roof drawing. Produced by Michelle Bettman (2018). Based on Zwet, C.J. van der (1974). Wijkcentrum 't Karregat Eindhoven. Bouwkunde TH Delft, p2_20
2_4

Bibliography

van Den Bergen, M., & Vollaard, P. (2003). Hinder en ontklontering: architectuur en maatschappij in het werk van Frank van Klingeren. Uitgeverij 010.

Luca, F.A. (2014). 't Karregat: ontwerp van een 'sociaal mechaniek'. History of Architecture & Urban Planning TU Delft.

Zwet, C.J. van der (1974). Wijkcentrum 't Karregat Eindhoven. Bouwkunde TH Delft, p 15.

Tivoli Vredenburg

Image sources:

Timeline Herman Hertzberger (L-R):

- Student residence Wrrspersstraat:
<https://www.ahh.nl/index.php/nl/projecten2/14-woningbouw/135-studentenhuis-weesperstraat-amsterdam>
- Drie hoven:
Eeckhout, A.D., e.a. (1981). Muziekcentrum Vredenburg. Delft: Technische universiteit Delft. p. 2-16.
- Centraal beheer:
<https://www.ahh.nl/index.php/nl/projecten2/12-utiliteitsbouw/85-centraal-beheer-hoofdkantoor-apeldoorn>
- Music centre Vredenburg:
<https://www.ahh.nl/index.php/nl/projecten2/13-cultuur/119-muziekcentrum-vredenburg>
- Ministry of social affairs:
<http://www.architectureweek.com/newsletters/notes/dats/564.dat>
- Chassé theater Breda:
<https://www.ahh.nl/index.php/nl/projecten2/13-cultuur/88-chasse-theater>
- Tivoli Vredenburg:
<https://www.ahh.nl/index.php/nl/projecten2/13-cultuur/29-tivolivredenburg>

Timeline development location and city (L-R):

- Castle Vredenburg:
Nagtzaam, C. (2012). Vredenburgplein: broeiest van historie. Retrieved from <http://www.geschiedenisbeleven.nl/vredenburgplein-broeiest-van-historie/>
- First plan hoog Catherijne:
Eeckhout, A.D., e.a. (1981). Muziekcentrum Vredenburg. Delft: Technische universiteit Delft. p. 1-7
- First plan Vredenburg:
- Final design:
<https://www.ahh.nl/index.php/nl/projecten2/13-cultuur/119-muziekcentrum-vredenburg>
- Model study for expansion:
Rotterdam, Het Nieuwe Instituut, HERT.
- Masterplan station area:
<http://www.fietsersbondutrecht.nl/doortrappers/2002-2/dt-04.html>
- First plan transformation:
Rotterdam, Het Nieuwe Instituut, HERT.
- Final plan Tivoli Vredenburg:
<https://www.ahh.nl/index.php/nl/projecten2/13-cultuur/29-tivolivredenburg>

Figure 1: Situation of the music centre Vredenburg in 1979.

Own drawing, modified from: Wortmann, A. (2005). De theaters of Herman Hertzberger. Rotterdam: Uitgeverij 010 publishers. p. 69.

Figure 2: Passage of Vredenburg with the different spaces of the street.

Wortmann, A. (2005). De theaters of Herman Hertzberger. Rotterdam: Uitgeverij 010 publishers. p. 69.

Figure 3: Section of the music centre.

Own drawing modified from: Eeckhout, A.D., e.a. (1981). Muziekcentrum Vredenburg. Delft: Technische universiteit Delft. p. 2-10.

Figure 4: Floorplan of the ground floor with function indication.

Own drawing modified from: Eeckhout, A.D., e.a. (1981). Muziekcentrum Vredenburg. Delft: Technische universiteit Delft. p. 2-5.

Figure 5: Open and closed diagram.

Own drawing modified from: Eeckhout, A.D., e.a. (1981). Muziekcentrum Vredenburg. Delft: Technische universiteit Delft. p. 2-11.

Figure 6: Axonometric of the music centre Vredenburg.

Own drawing, based on: Eeckhout, A.D., e.a. (1981). Muziekcentrum Vredenburg. Delft: Technische universiteit Delft. p. 2-4 & 2-15.

Figure 7: Construction model of the different layers of the location.

Own drawing, based on: <http://www.bouwputrecht.nl/2016/11/25/kasteelhistorie-verbeeld/>

Figure 8: Study to the different column connections.

- Eeckhout, A.D., e.a. (1981). Muziekcentrum Vredenburg. Delft: Technische universiteit Delft. p.1.

- <https://www.ahh.nl/index.php/nl/projecten2/13-cultuur/119-muziekcentrum-vredenburg>

Figure 9: Different ceiling heights used in the building.

Eeckhout, A.D., e.a. (1981). Muziekcentrum Vredenburg. Delft: Technische universiteit Delft. p. 2-46.

Figure 10: Initial construction concept used in early designs.

Eeckhout, A.D., e.a. (1981). Muziekcentrum Vredenburg. Delft: Technische universiteit Delft. p. 5-5

Figure 11a: Sketch of different spaces.

<https://www.ahh.nl/index.php/nl/projecten2/13-cultuur/119-muziekcentrum-vredenburg>

Figure 11b: Sketch of different spaces.

Reinink, W. (1990). Herman Hertzberger. Rotterdam: uitgeverij 010 publishers. p.61.

Figure 12: Floorplan of the ground floor of the music palace Tivoli Vredenburg.

Own drawing, modified from: Abrahamse, J.E. (2014). Stad in stad. De architect. p. 68-80.

Figure 13: Section of the music palace Tivoli Vredenburg.

Own drawing, modified from: Abrahamse, J.E. (2014). Stad in stad. De architect. p. 68-80.

Bibliography:

Abrahamse, J.E. (2014). Stad in stad. De architect. p. 68-80.

Eeckhout, A.D., e.a. (1981). Muziekcentrum Vredenburg. Delft: Technische universiteit Delft.

Gemeente Utrecht. (sd). De aanleiding. Retrieved from <http://cu2030.nl/pagina/de-aanleiding>

Haterd, J. van de. (2015). Een muziekstad met vijf zalen. Zichtlijnen, nr. 158. p. 36-39.

Hendriks, T. (1979). Nieuwe Utrechts muziekcentrum in gebruik genomen. De telegraaf.

Hertzberger, H. (2018). Tijdlijn. Retrieved from <https://www.hertzberger.nl/index.php/nl/biografie/tijdlijn>.

Nagtzaam, C. (2012). Vredenburgplein: broeiest van historie. Retrieved from <http://www.geschiedenisbeleven.nl/vredenburgplein-broeiest-van-historie/>

Projectorganisatie stationsgebied, gemeente Utrecht. (2008). Inventarisatie archeologische waarden. Retrieved from http://www.cu2030.nl/images/oud/CONT/1/inventarisatie_archeologie_stationsgebied_utrecht.pdf.

Reinink, W. (1990). Herman Hertzberger. Rotterdam: uitgeverij 010 publishers.

Wortmann, A. (2005). De theaters of Herman Hertzberger. Rotterdam: Uitgeverij 010 publishers.