

# Living Rooms of Lavapiés

Hosting Open Third Place  
in and around Madrid's  
hostile inner-city plazas

Isabel Mathers

5736277

03/07/2024

ADC Graduation Studio - P5 Presentation







1. Outsiders and Third Space



2. Third Spaces of Lavapiés

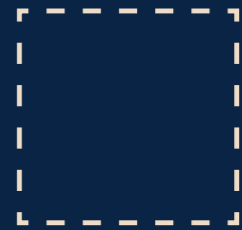

3. Defining Open Third Space

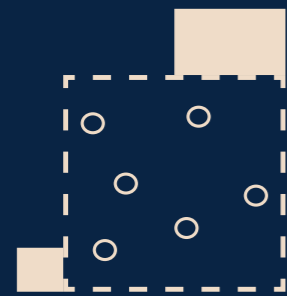

4. Creating an Open Third Space





# 1. Outsiders and Third Space

2. Third Spaces of Lavapiés

3. Defining Open Third Space

4. Creating an Open Third Space



# Newcomers and the Melting Pot





Venezuela

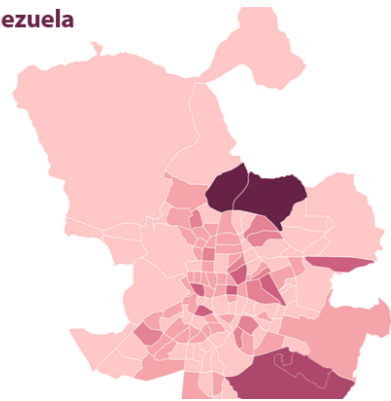

Alemania

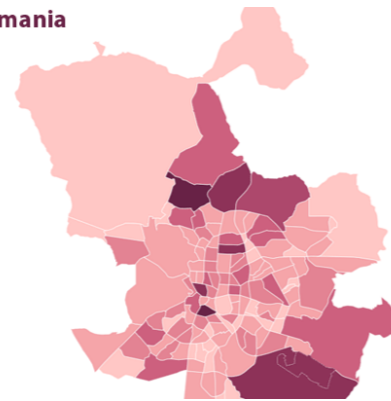

Argentina

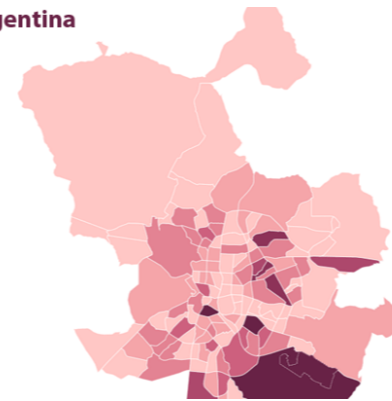

Bangladés

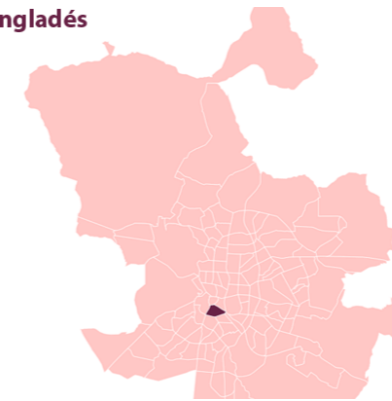

Bélgica

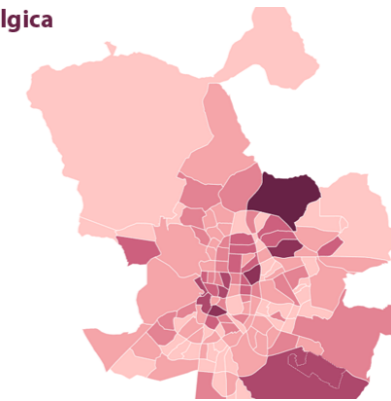

Bolivia

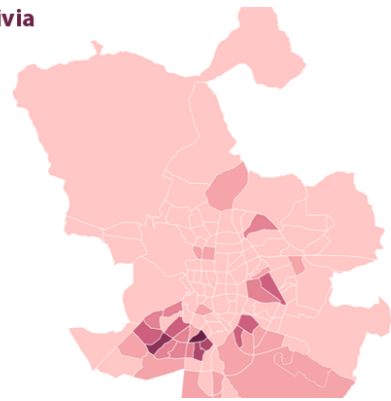

Brasil

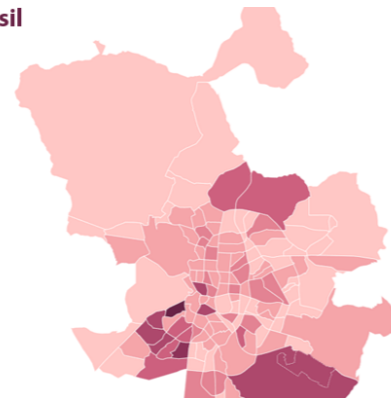

Bulgaria

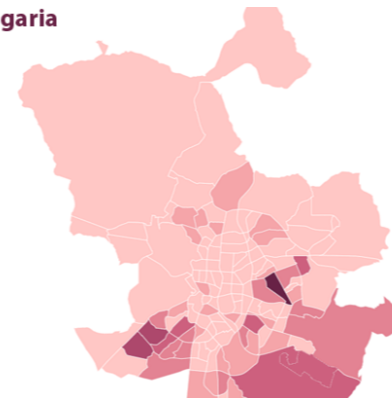

Chile

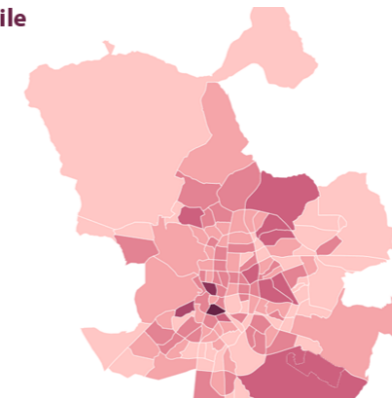

China

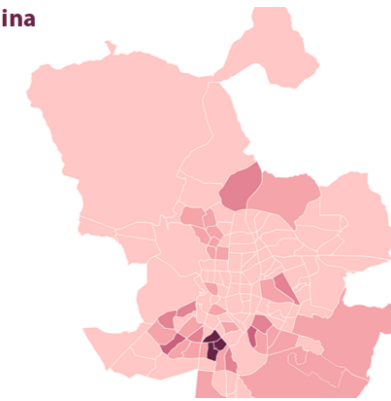

Colombia

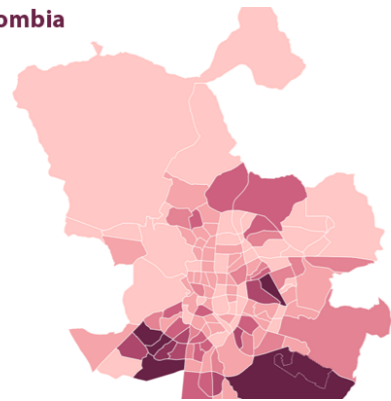

Cuba

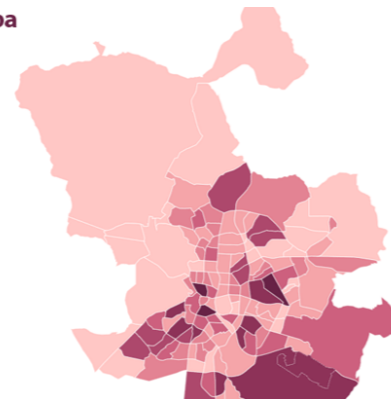

Ecuador

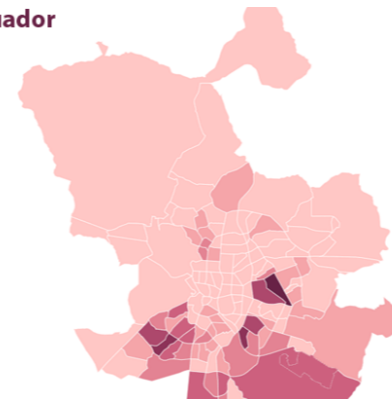

El Salvador

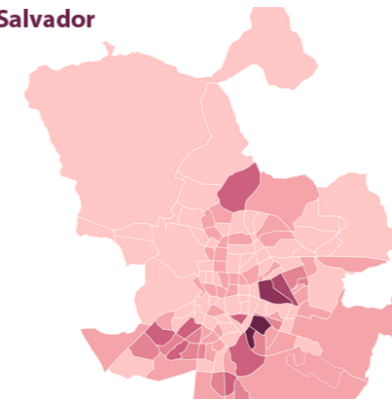

Estados Unidos

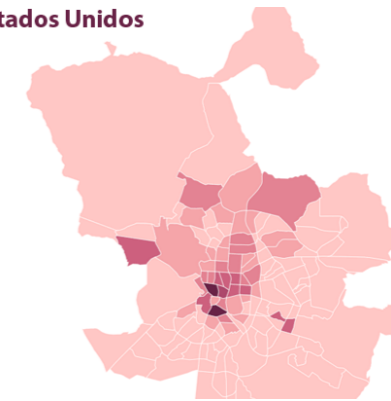

Filipinas

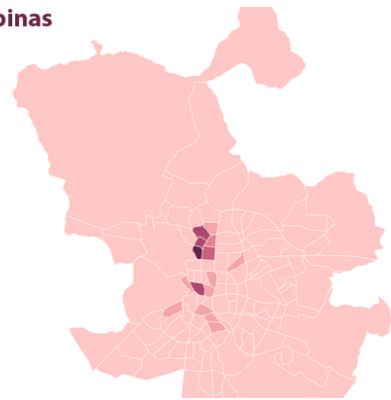

Francia

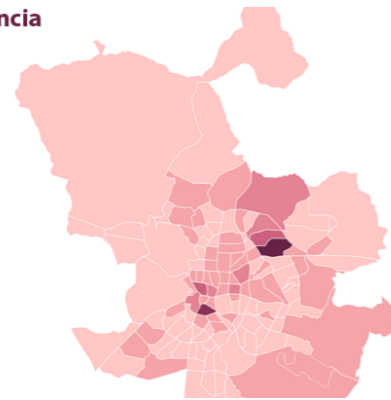

Guatemala

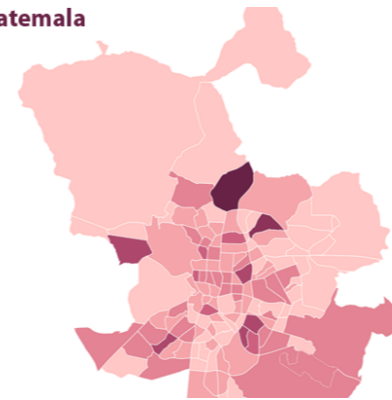

Guinea Ecuatorial

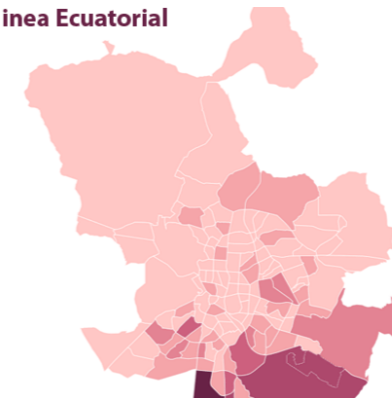

Uruguay

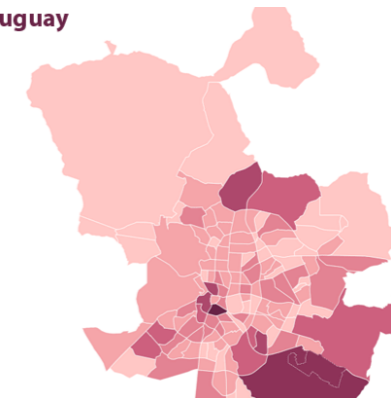

*Concentrations of foreign-born inhabitants in Madrid (Ayuntamiento de Madrid, 2017)*



# Lavapiés, Madrid

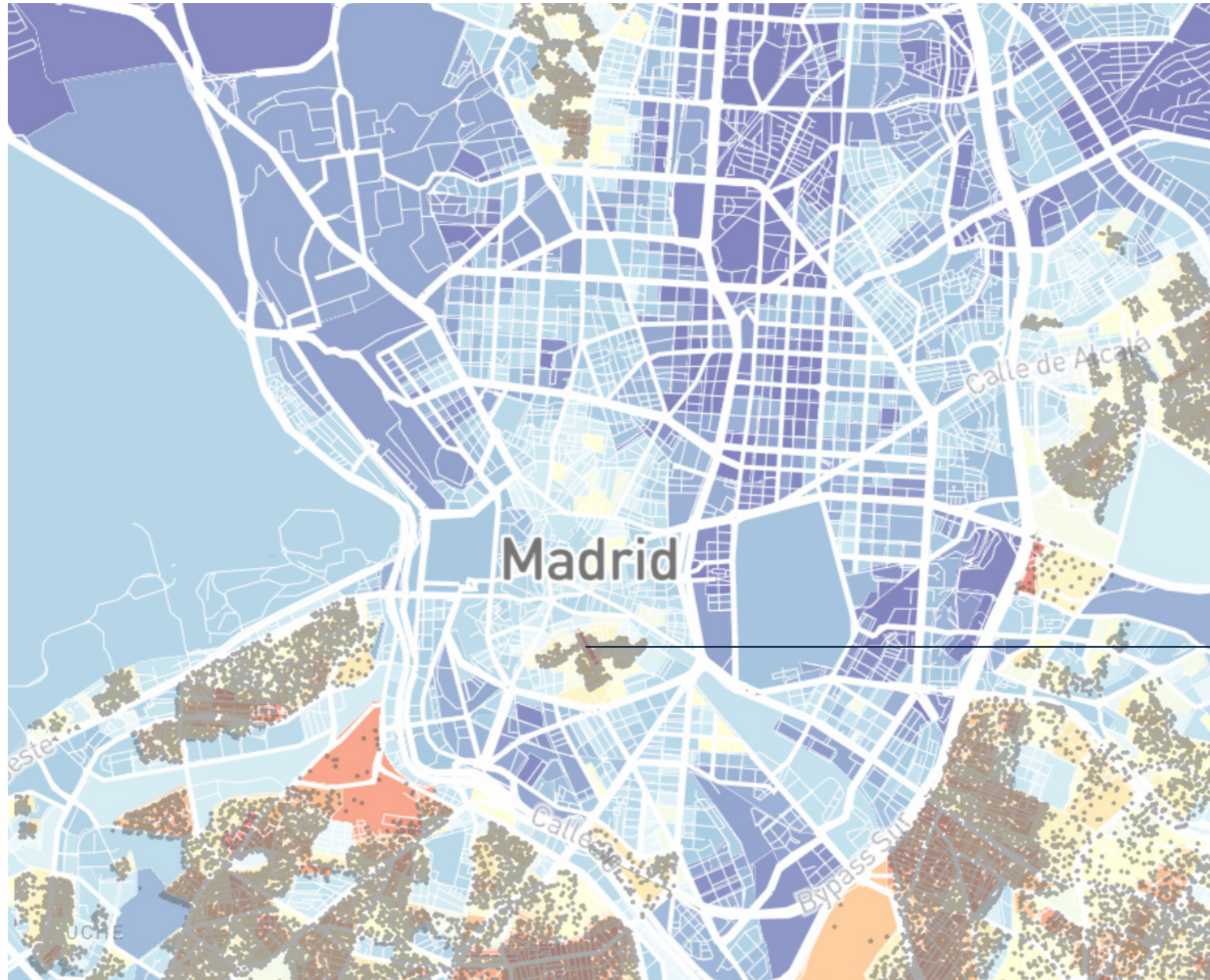

○ Lavapiés, Centro

Net income per person in Madrid, overlaid with first generation immigrant population



# Lavapiés, Madrid

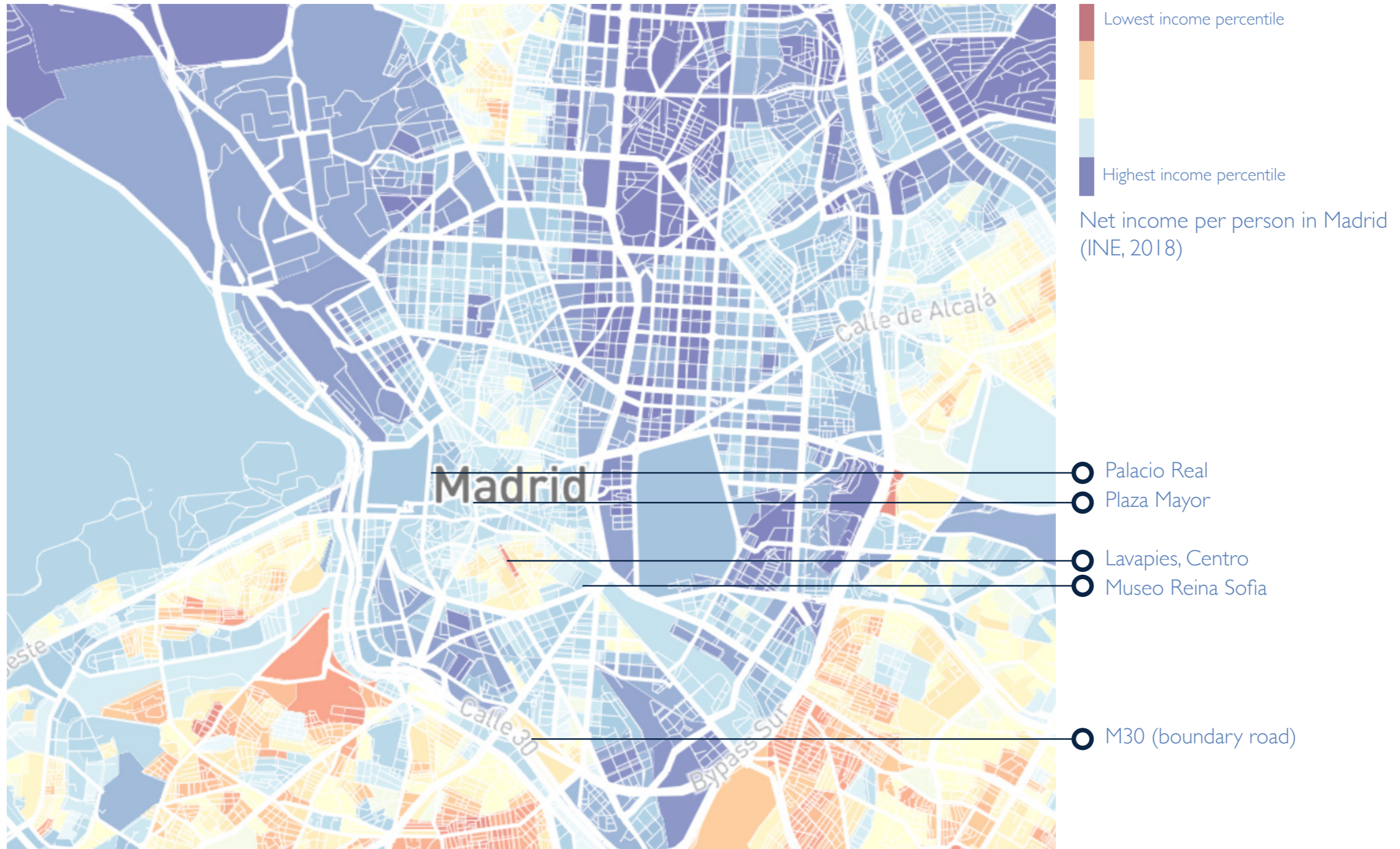



# Lavapiés as a Place of Arrival

## Formation of Lavapiés

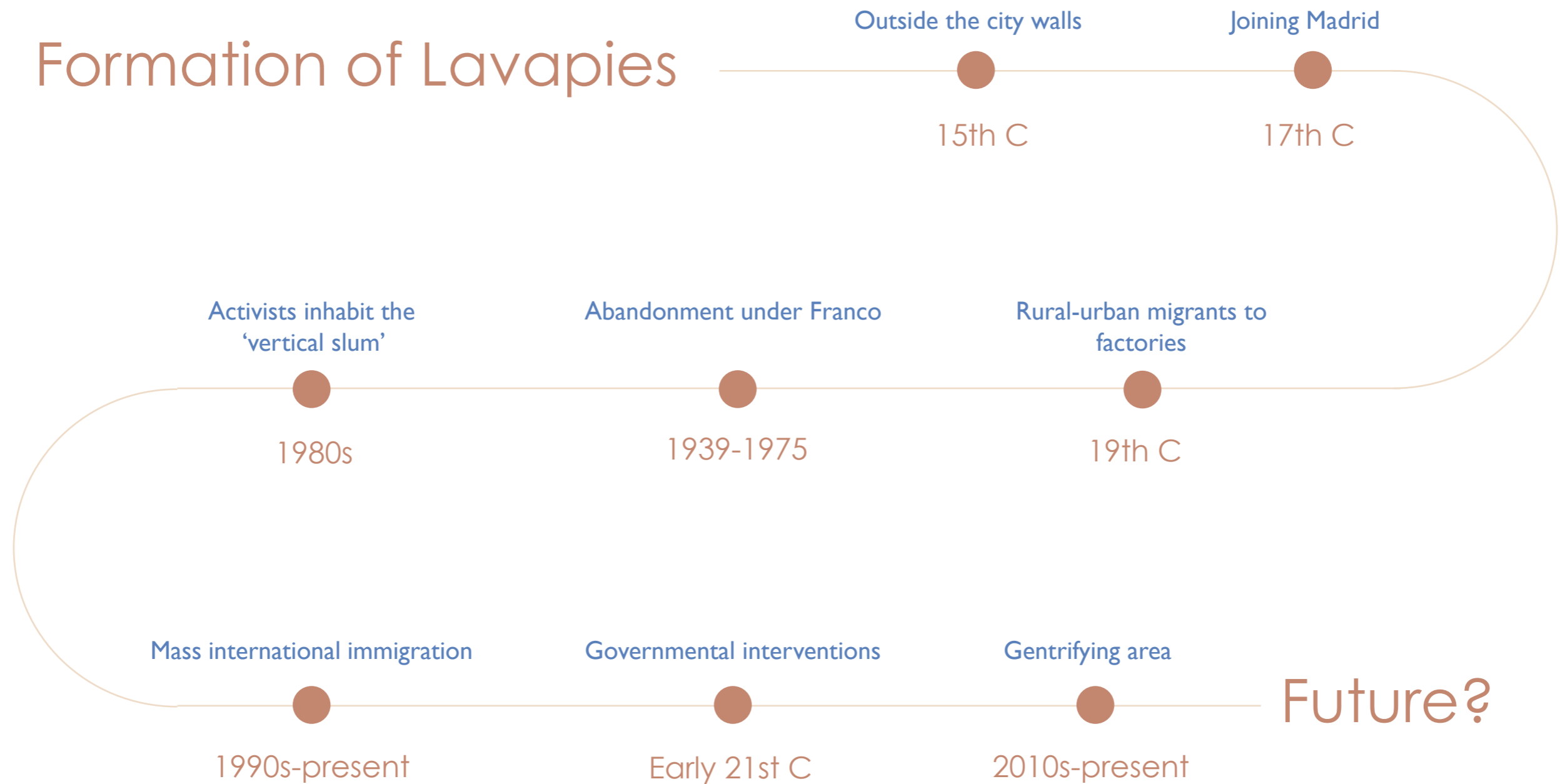



# Competing forces of Lavapiés

## Activists



Retratos, laboratorio2  
01-06-2001



Retrato, laboratorio2  
01-06-2001



Retratos, Laboratorio2  
01-06-2001



Retratos, Laboratorio2  
01-06-2001



Tourists  
and hipsters

Governmental forces



Lavapiés

Aging Spanish residents



Working-class  
immigrants





# Lavapiés as a Melting Pot?

*“A neighbourhood of exemplary cohabitation”*

Constantini, 2018, regarding historic character of Lavapiés





# Lavapiés as a Melting Pot?



Yellow protest flags (site photos, 2023)

Protest in N. Mandela (Getty, 2019)



# Lavapiés as a Melting Pot?





# Built Conditions and the Melting Pot

“Unexpected encounters with difference”



Lower East Side, NYC (Rose, 1980)



Lincoln Centre, NYC (Authenticated News, 1965)



# Defining Third Space

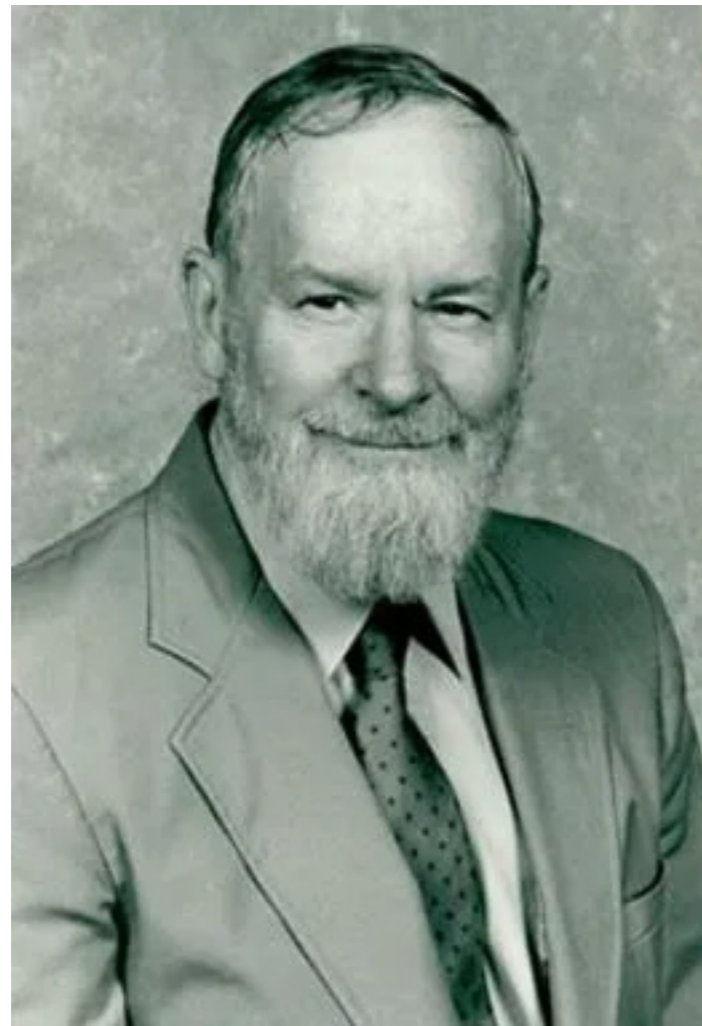

Ray Oldenburg

*A social space outside of home or work, where we can make new connections over shared interests and activities*



# Ingredients of the Melting Pot



Encounters in the public realm, Sydney (Woods Bagot, n.d.)



1. Outsiders and Third Space

■  
■  
■ 2. Third Spaces of Lavapiés

3. Defining Open Third Space

4. Creating an Open Third Space



# Third Spaces of Lavapiés



Lavapiés, Madrid (1890, overlaid with parks today)



A gathering in Plaza Arturo Barea (solarolivar, ca. 1970)



A gathering in Plaza Corral de Comedias (1935)



# Changing Third Spaces of Lavapiés



Remodelling Arturo Barea (2001)

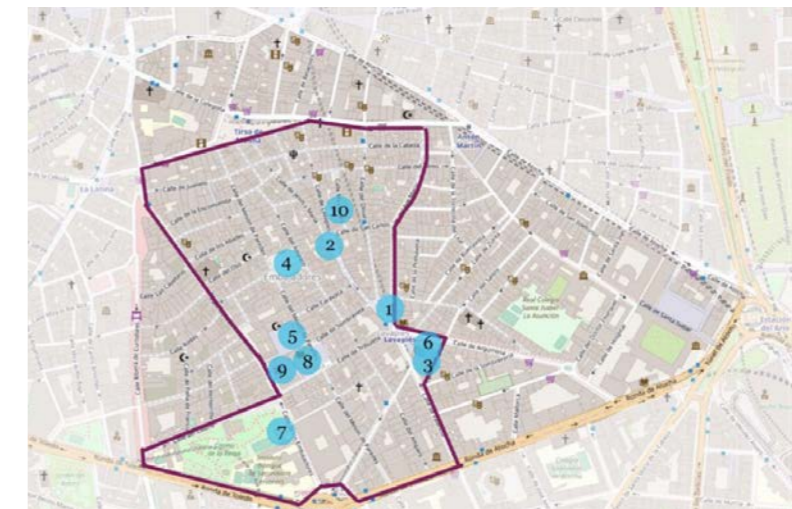

Early 21st C interventions (MFLN, 2020)



# Changing Third Spaces of Lavapiés

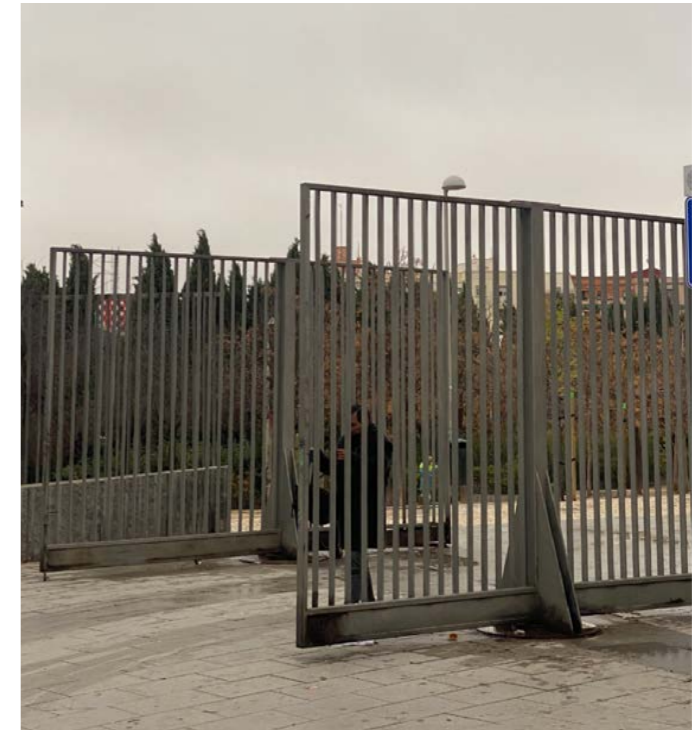

○ Parque Casino de la Reina

Fieldwork photographs (2023)



# Changing Third Spaces of Lavapiés



○ Plaza de Arturo Barea

From top, clockwise:  
Gathering (solarolivar, ca. 1970)  
Completed square (Linazasoro, 2001)  
Fieldwork photographs (2023)



# Changing Third Spaces of Lavapiés



N. Mandela (Google Street View, 2005)

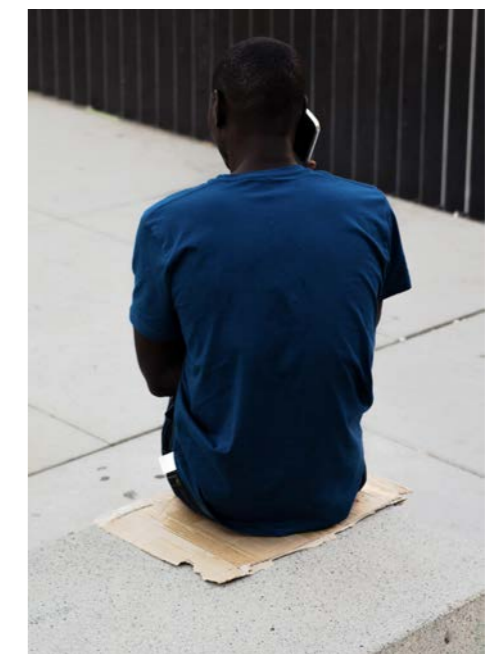

N. Mandela (Caicedo, n.d.)

o Plaza de Nelson Mandela



# Encounters or Avoidance?



Sense of insecurity (adapted El Confidencial, 2022) and CCTV Cameras (2023)

"BALTIMORE FEELING"

A day in the 'narcoesquina' of Lavapiés: this is how the degradation of a neighborhood is explained

Four streets, two squares and a multitude of narcopisos are the trench fields of the sale and consumption of narcotics in the neighborhood. We located some. Neighbors accuse the institutions of abandonment. Has Lavapiés returned at the 80s?



Nelson Mandela Square from inside a house. (A. M. V.)

Newspaper Article (El Confidencial, 2022)



Camera on site visit (2023)



# Spaces of Encounter in Lavapies



Esta Es Una Plaza (2023)



Eskalera Karakoia Centre (2023)



Dragones de Lavapies pitch (2023)





# Third Space

Nelson Mandela Square, Lavapies (Caicedo, n.d.)

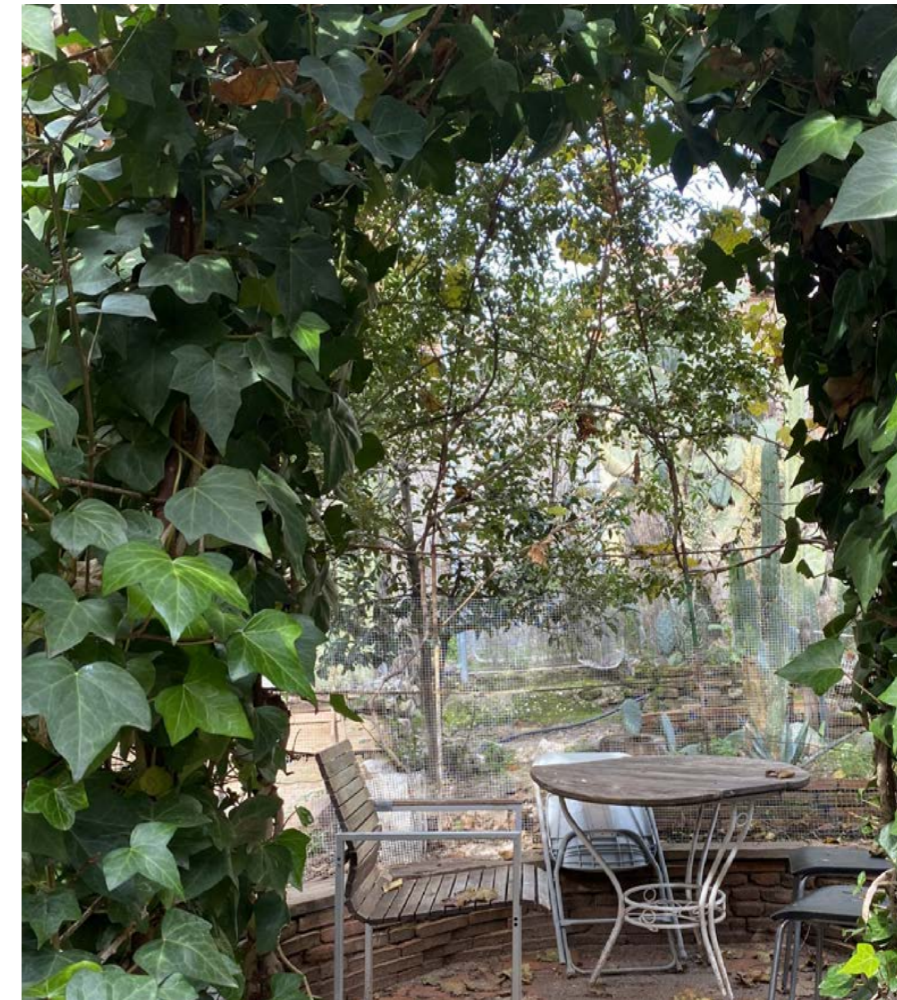

# Third Space

Esta Es Una Plaza, Lavapies (2023)



# Architect



# Third Space

Nelson Mandela Square, Lavapies (Caicedo, n.d.)

# User

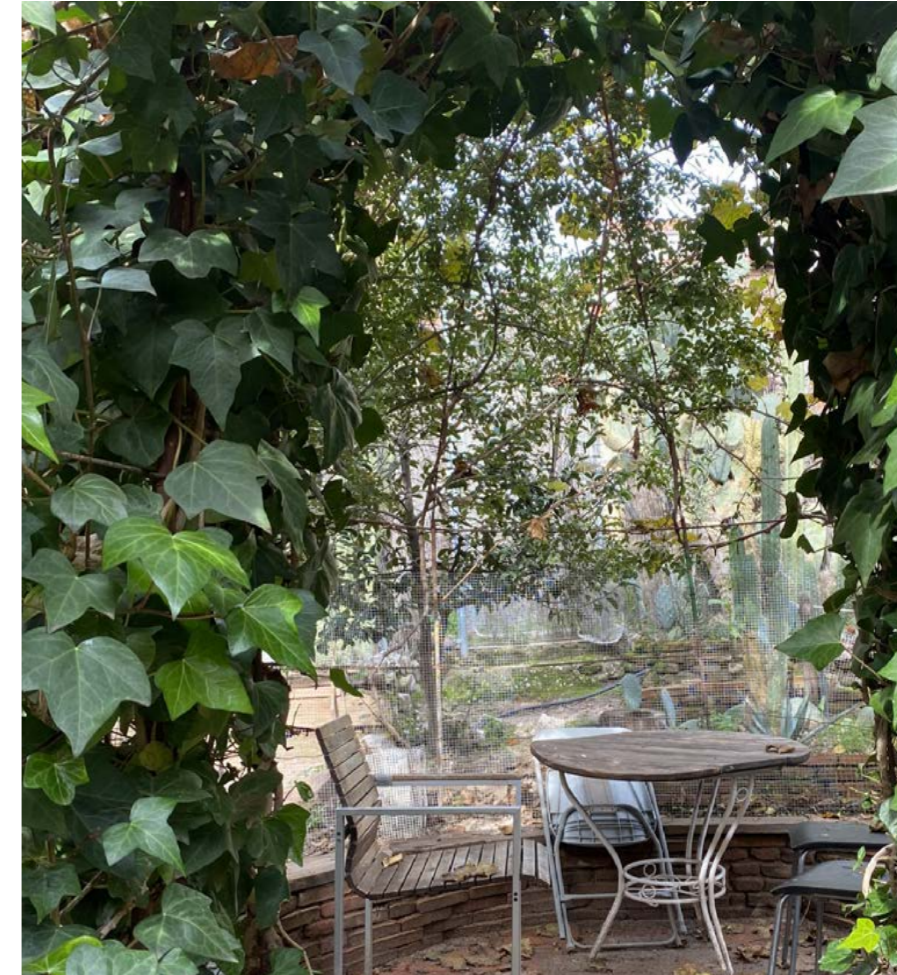

# Third Space

Esta Es Una Plaza, Lavapies (2023)



# Brittle



# Third Space

Nelson Mandela Square, Lavapies (Caicedo, n.d.)

# Open

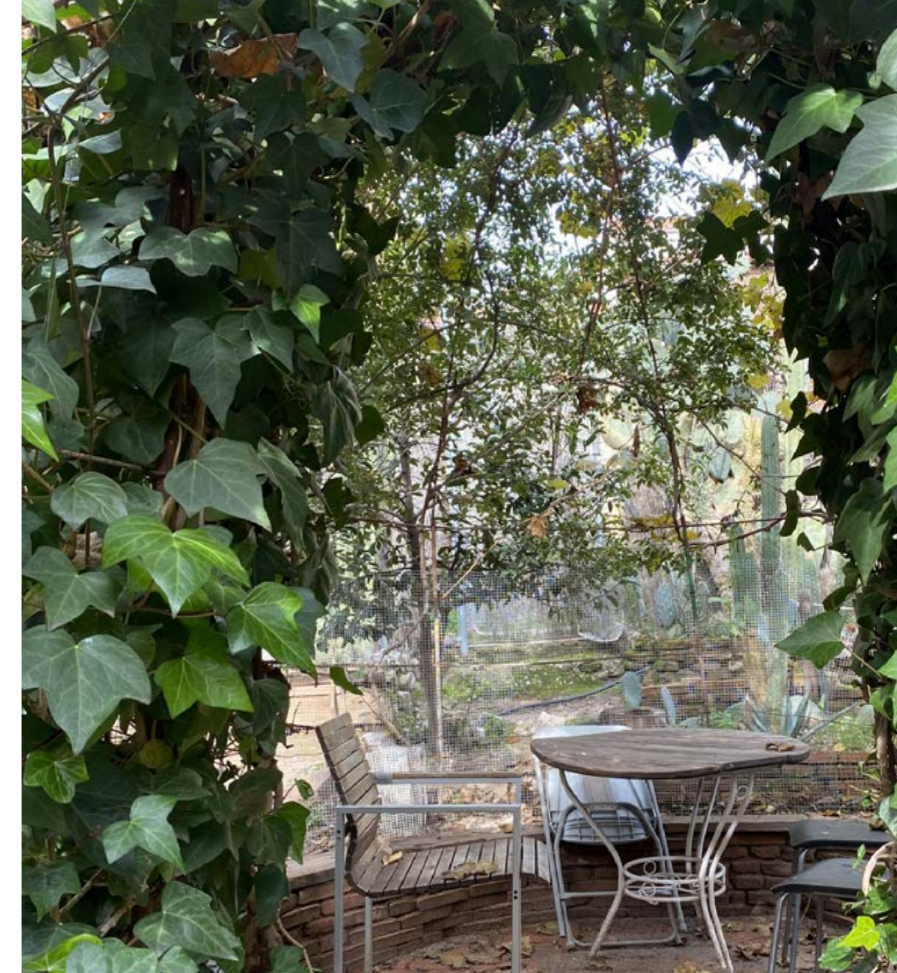

# Third Space

Esta Es Una Plaza, Lavapies (2023)



# Brittle Third Places of Lavapiés





# Brittle Third Places of Lavapiés?

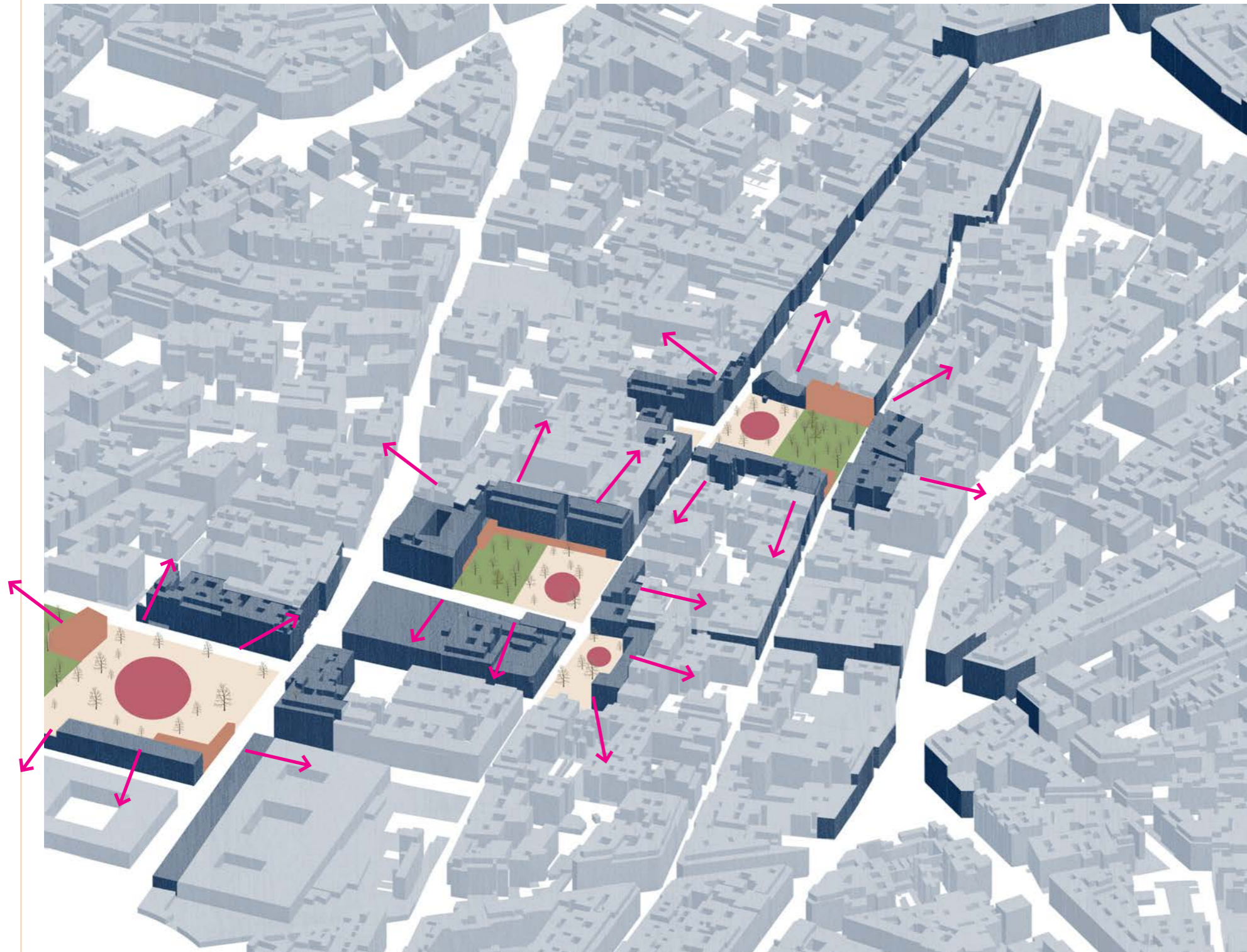



1. Outsiders and Third Space

2. Third Spaces of Lavapiés

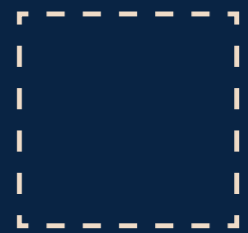

3. Defining Open Third Space

4. Creating an Open Third Space



# Brittle



## Third Space

Nelson Mandela Square, Lavapies (Caicedo, n.d.)

# Open

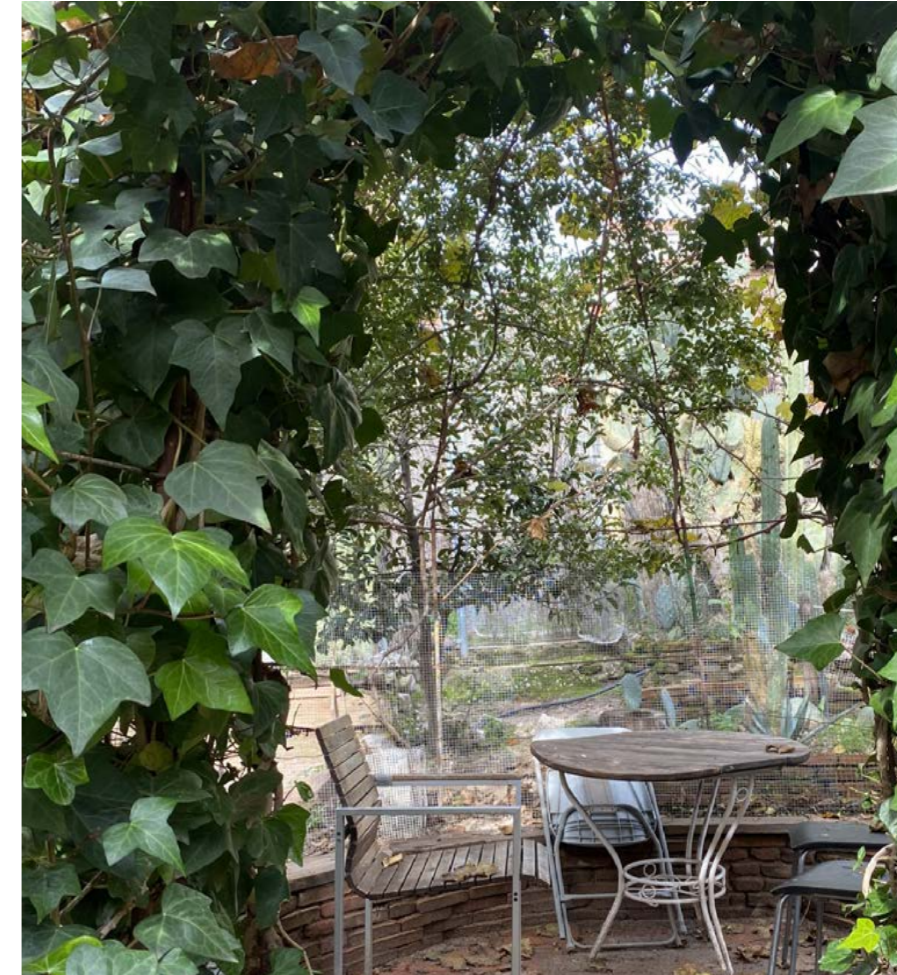

## Third Space

Esta Es Una Plaza, Lavapies (2023)

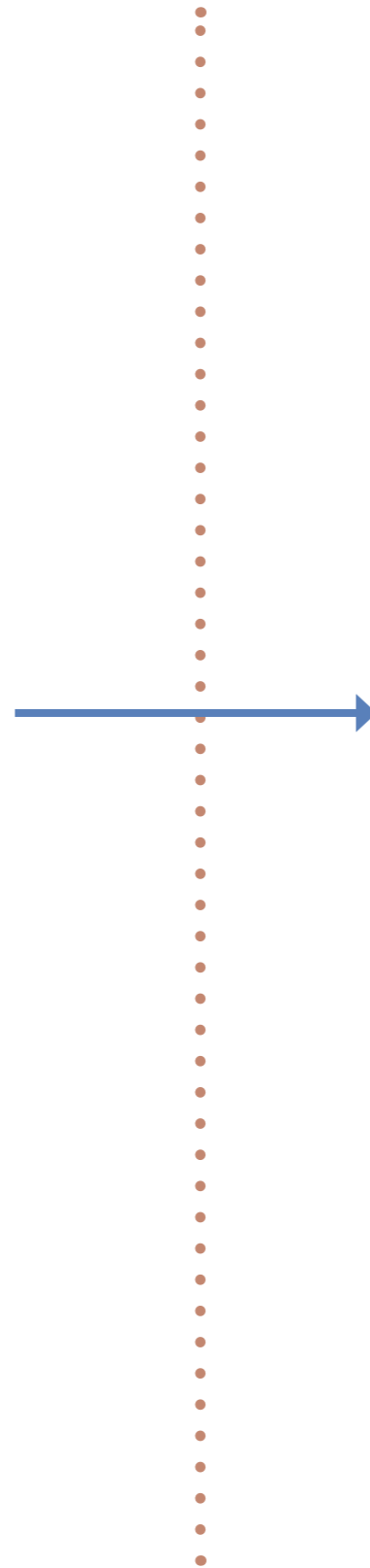



# Plaza de Nelson Mandela

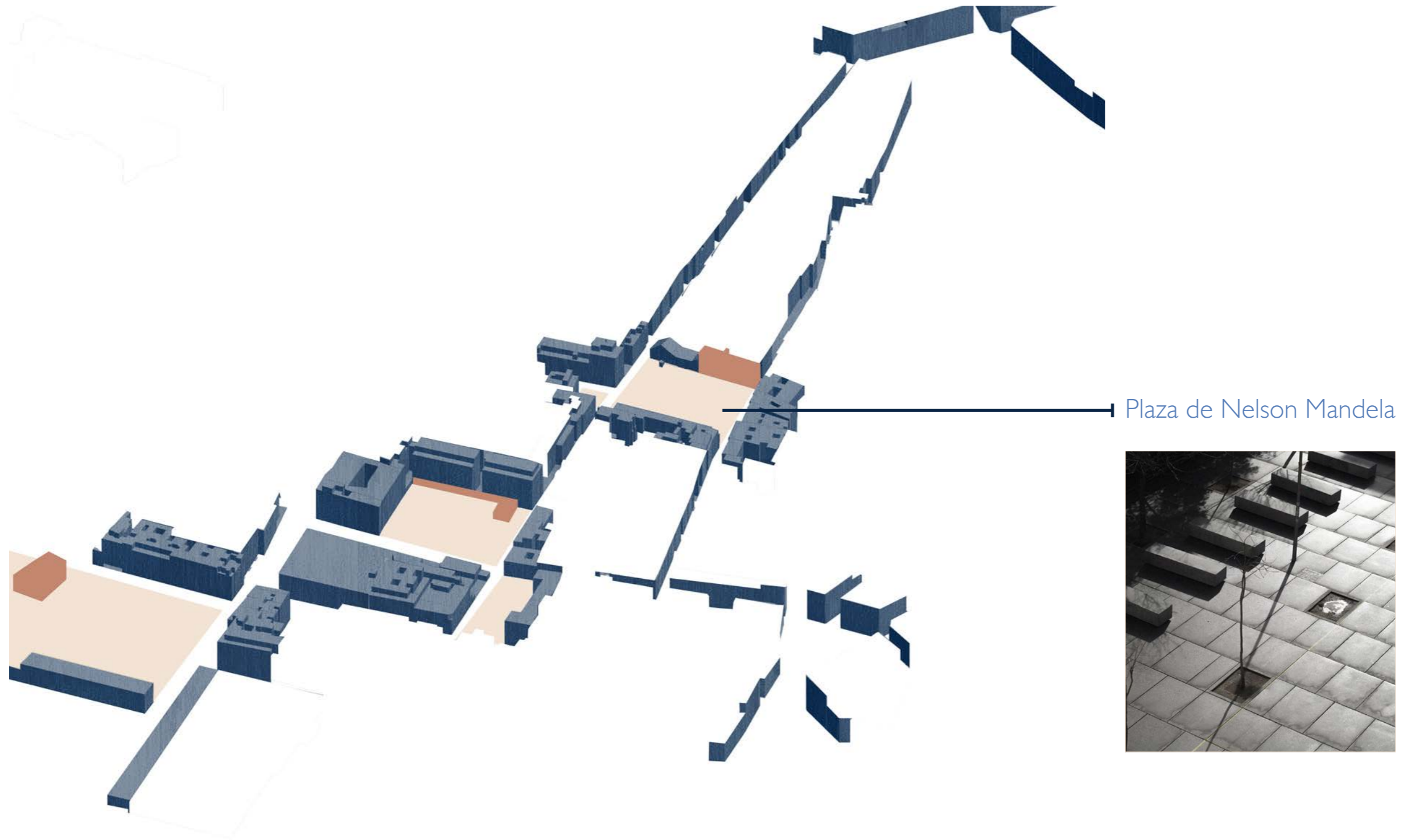



# A place for newcomers

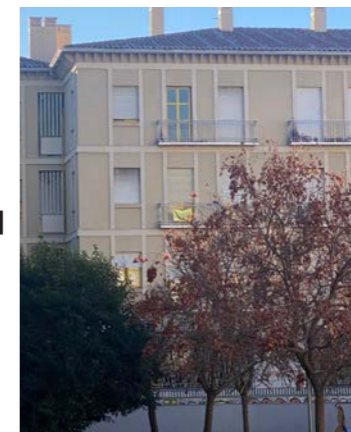
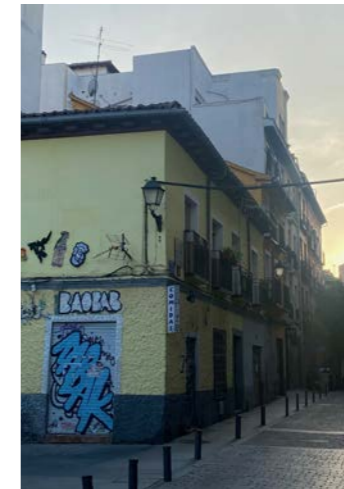
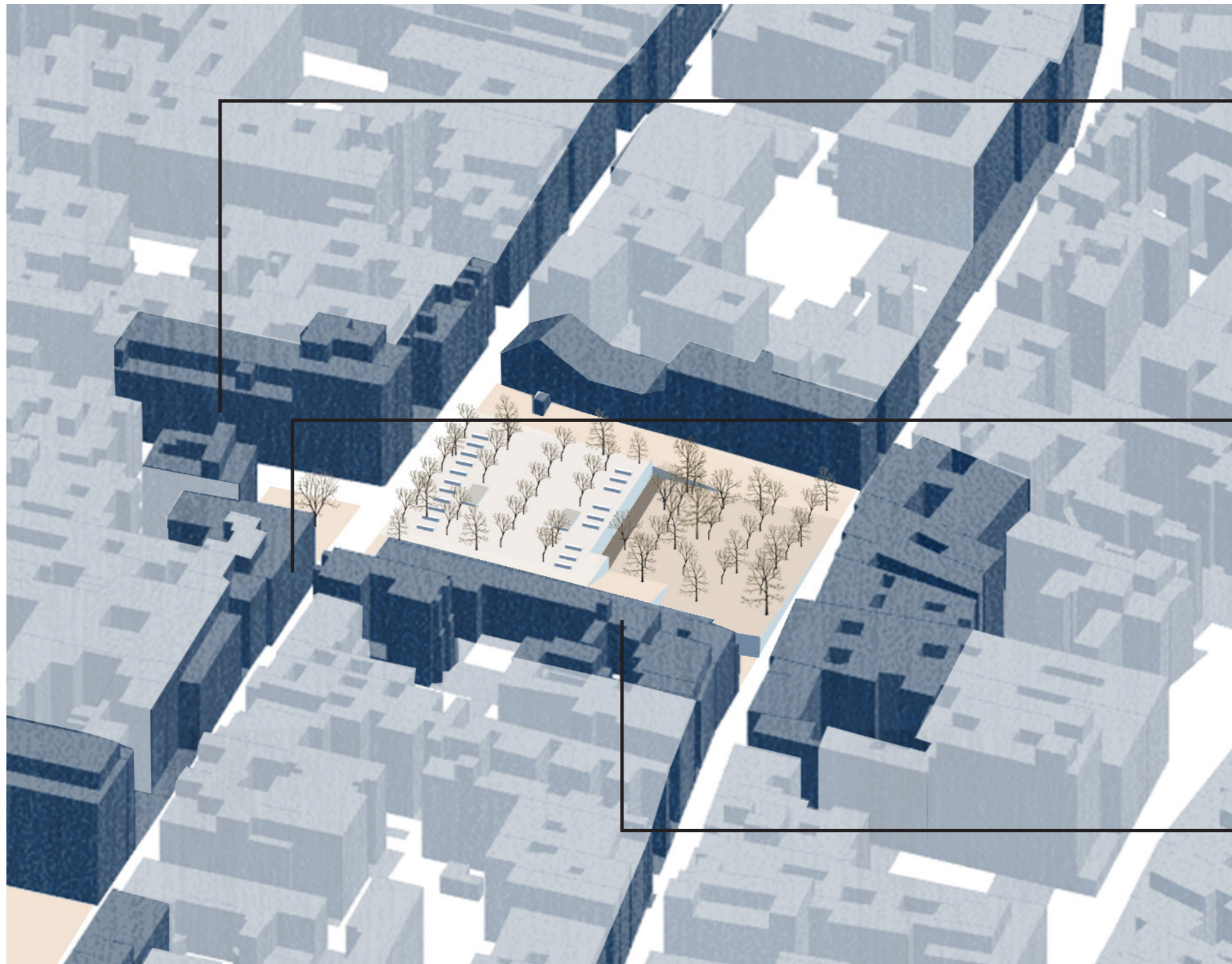



# A place for newcomers

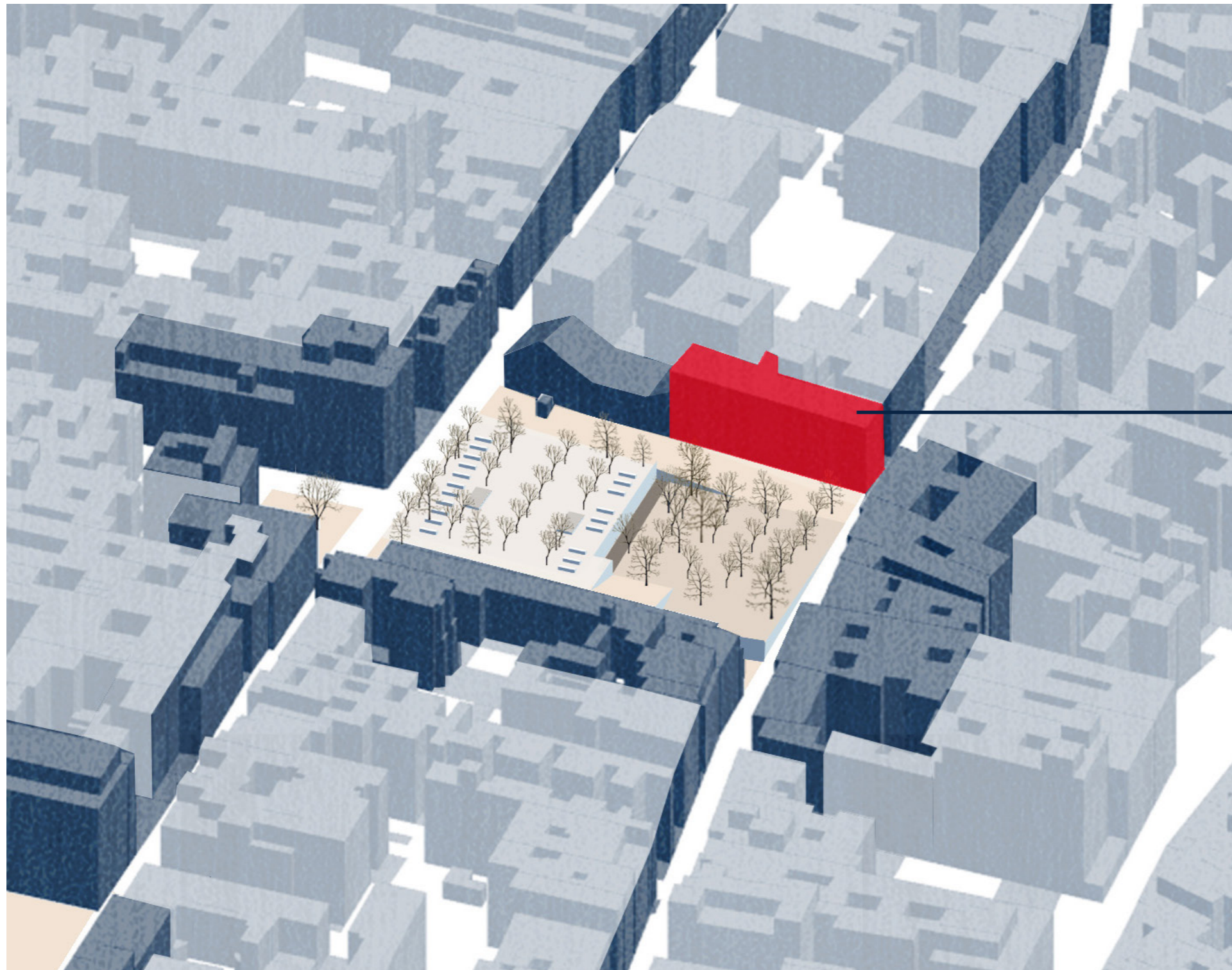

La Quimera



# A place for newcomers?



La Quimera event (Minube, ca.2015)

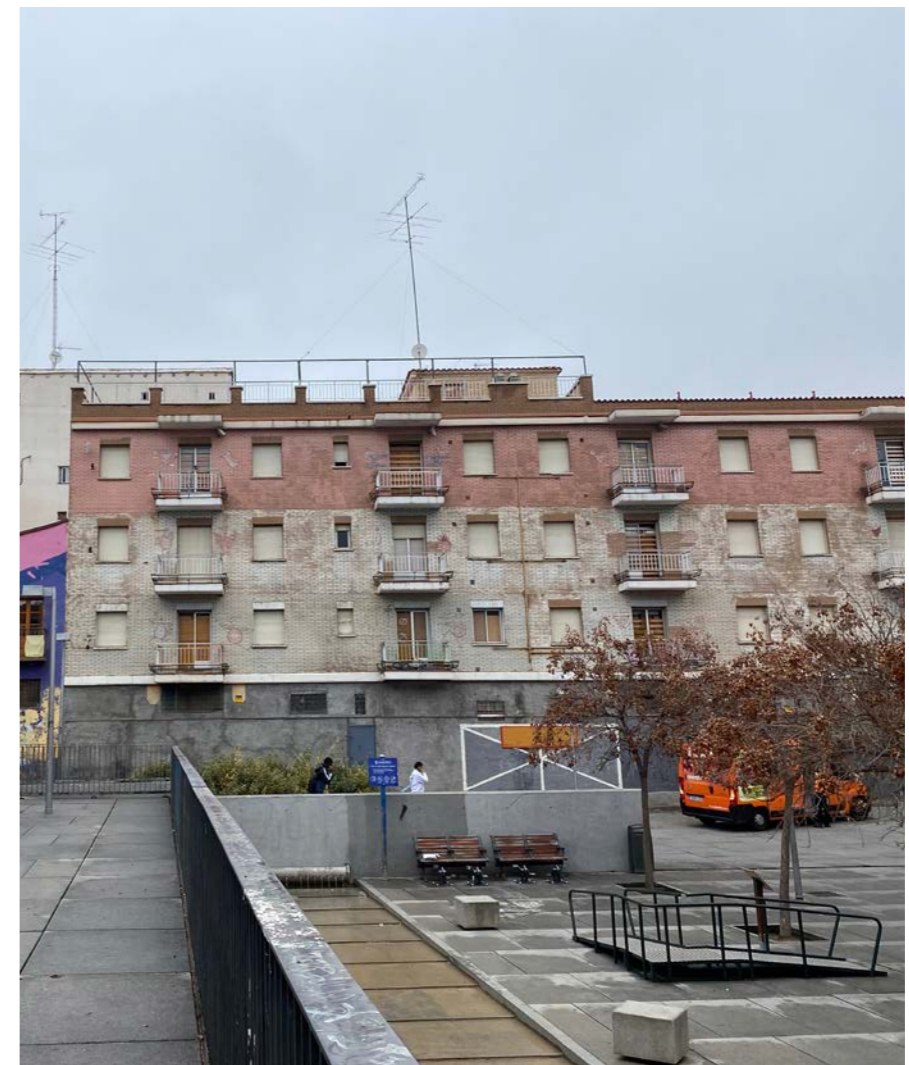
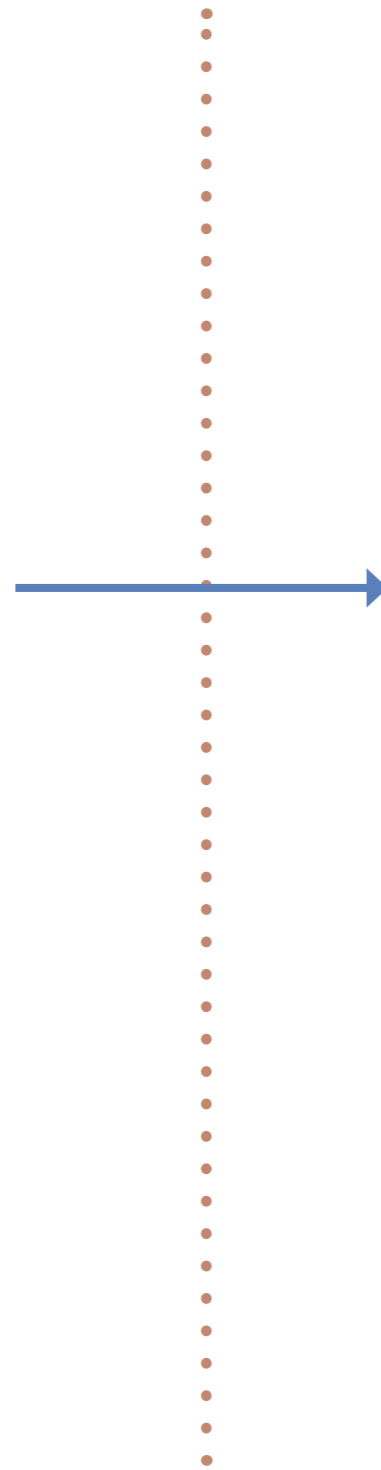

Empty La Quimera, on N.Mandela Square (2023)



# Methods of Analysis

Wasted external space

Lack of sociability on stairs

Place of abandonment

Unused corridors

Bedrooms

Single window

Living Space

Dining Room? Facing to one

Corridor (to bathroom)

limited adaptation  
↓  
A lack of people or care

A sense of home?



Disordered



Thresholds



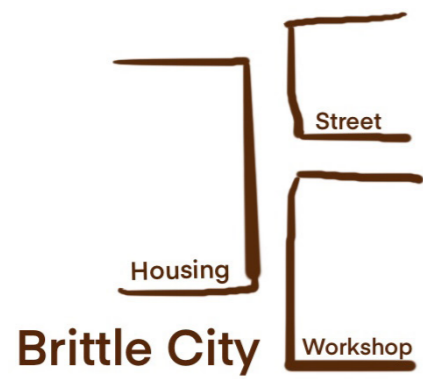

Spatial Thresholds

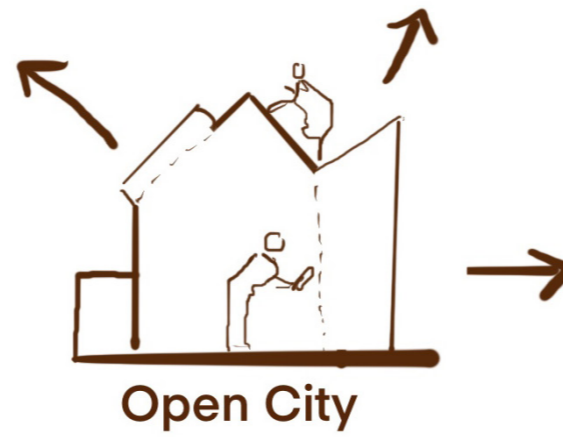
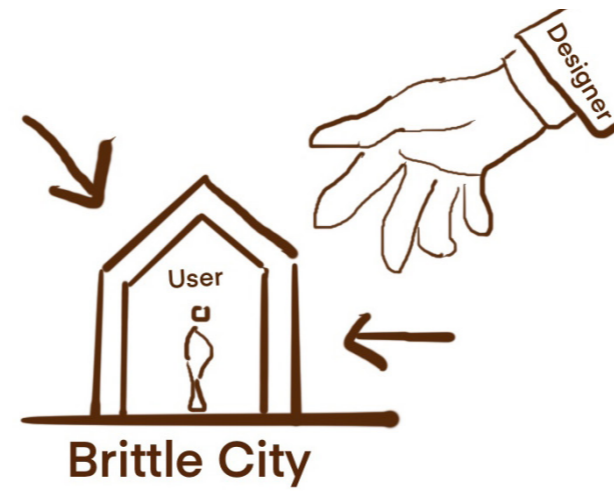

Designer-User Thresholds

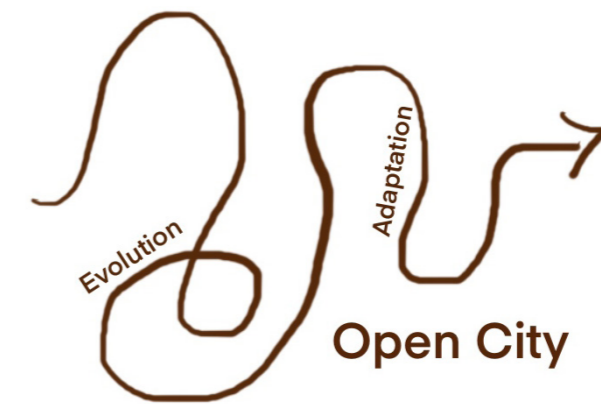
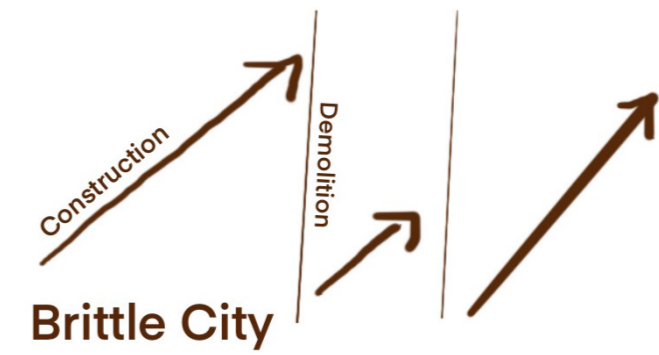

Temporal Thresholds



# Temporal Thresholds



Plaza de Nelson Mandela (Nomecalles, 2004)



Plaza de Nelson Mandela (Nomecalles, 2006)



Plaza de Nelson Mandela (Nomecalles, 2007)



# Temporal Thresholds



Plaza de Nelson Mandela (Nomecalles, 2004)





# Temporal Thresholds



Plaza de Nelson Mandela (Nomecalles, 2007)



N. Mandela (Google Street View, 2005)



# Bridging Temporal Thresholds

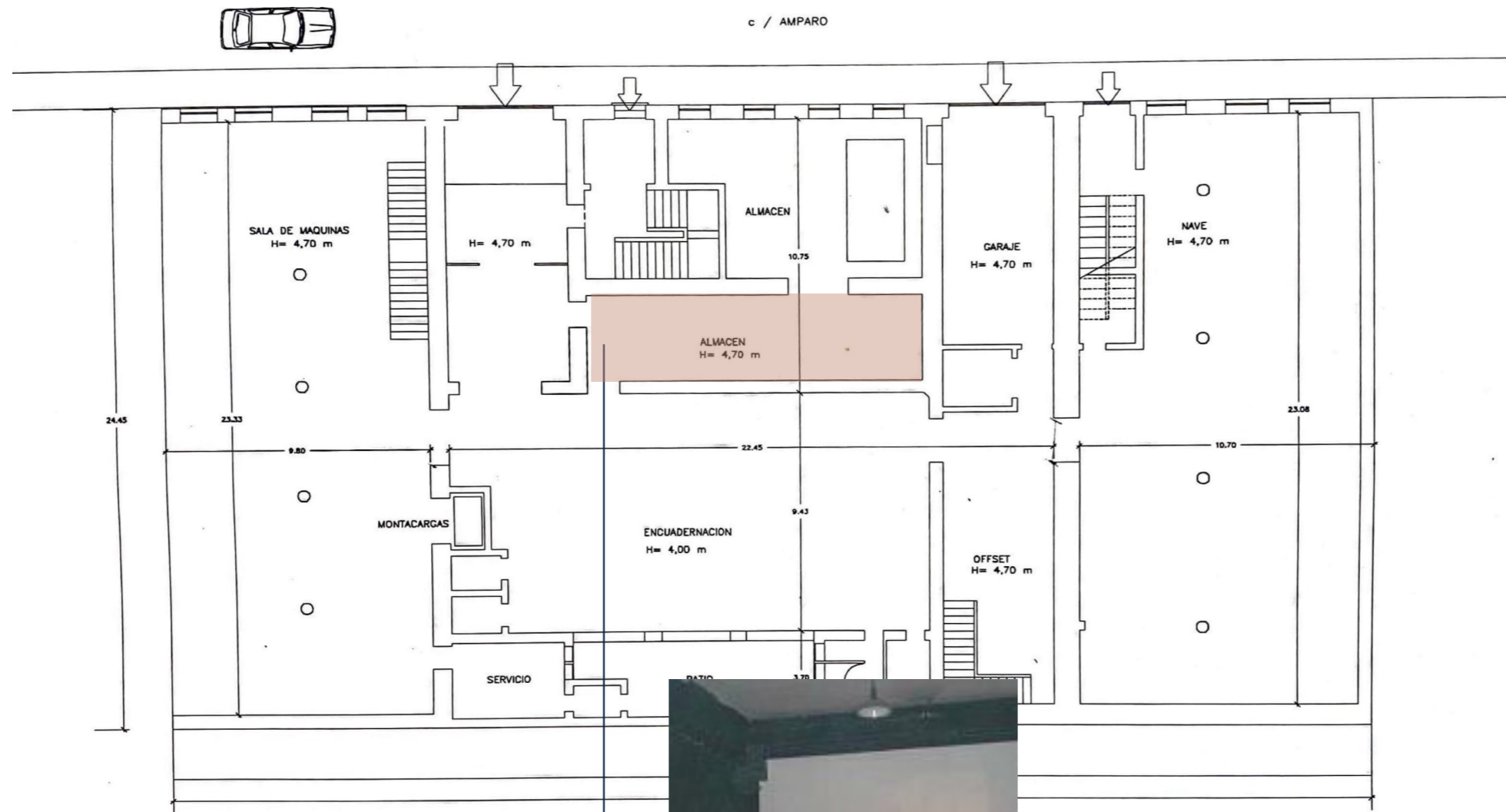



# Spatial Thresholds

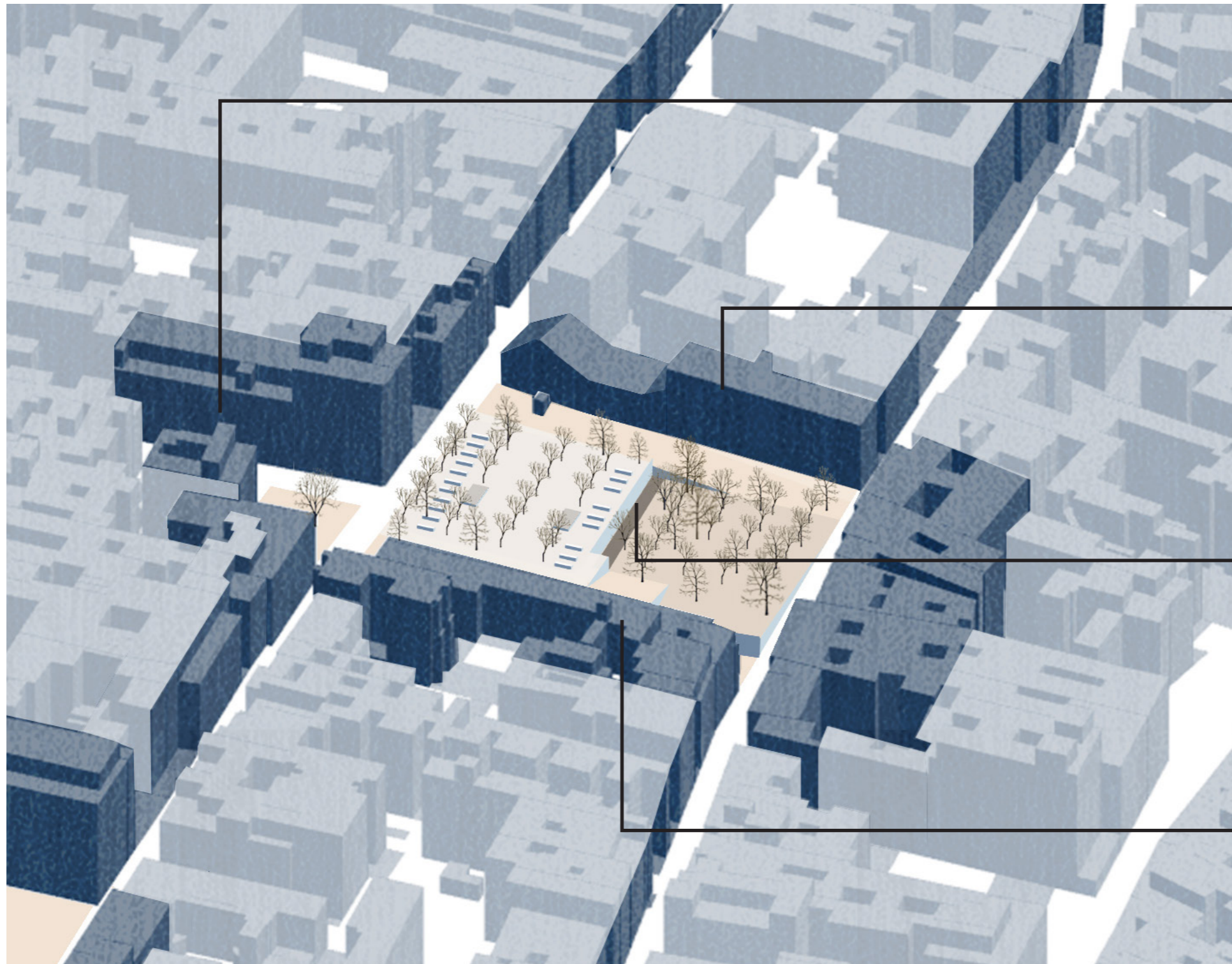



# Bridging Spatial Thresholds



The exterior of La Quimera, 2015 (screenshot from Google Street View)



La Quimera event (Minube, ca.2015)



# Designer-User Thresholds

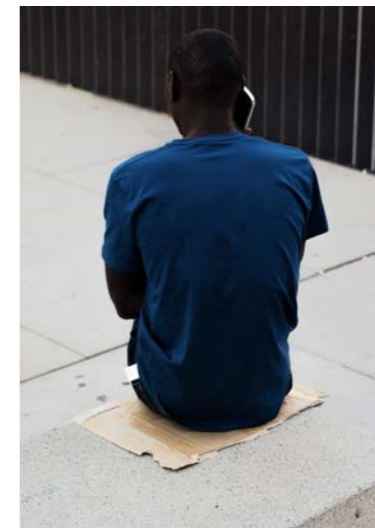
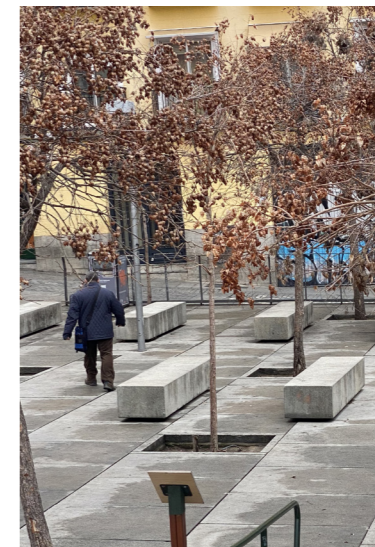
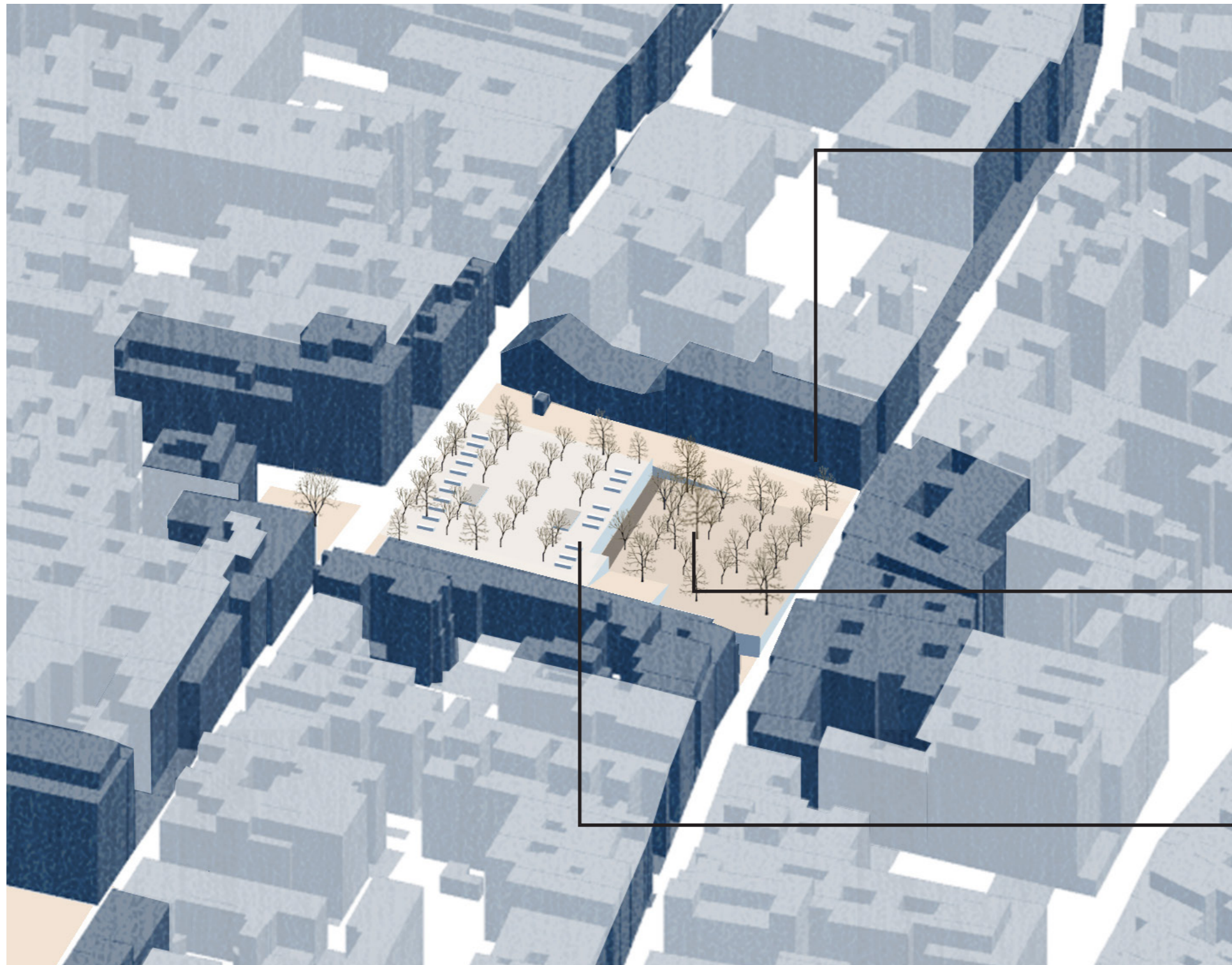



# Bridging Designer-User Thresholds



A gathering in the ground floor of the reoccupied La Quimera building (Vigier, 2015)



Self-construction of Labo 3 ("fotos "autoconstrucción": acondicionamiento Laboratorio3", Virxin, 2002)



# Disordered Thresholds

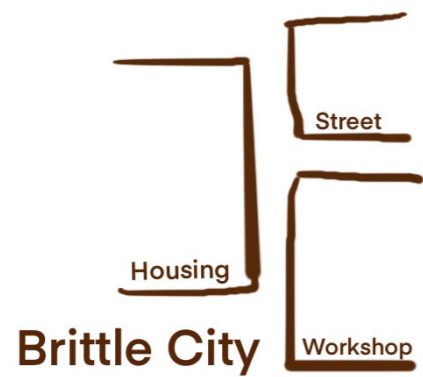

Open City

Spatial Thresholds

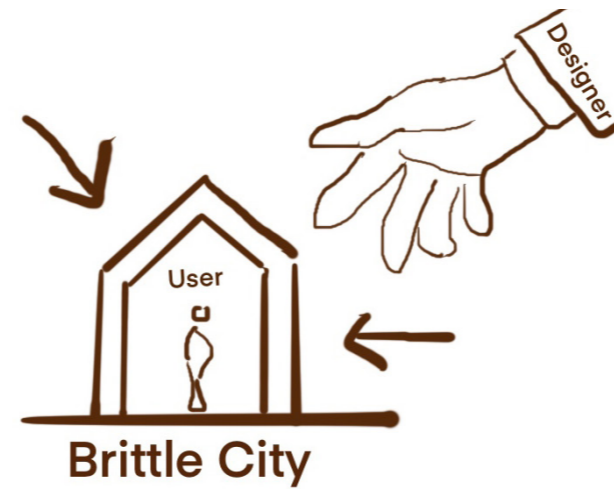

Open City

Designer-User Thresholds

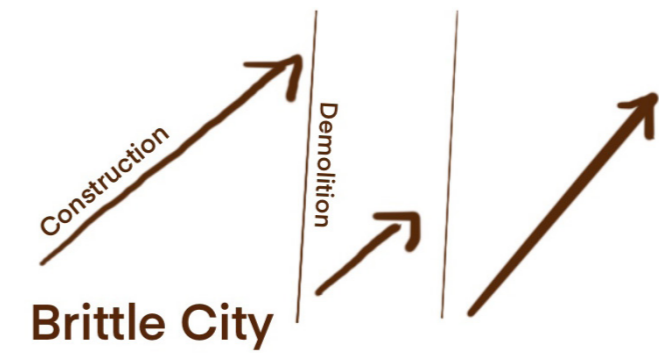

Open City

Temporal Thresholds



1. Outsiders and Third Space

2. Third Spaces of Lavapiés

3. Defining Open Third Space

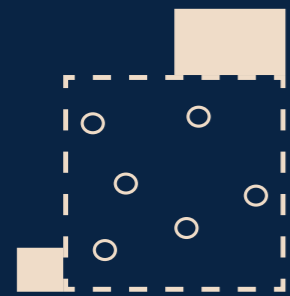

4. Creating an Open Third Space



# Brittle Third Space

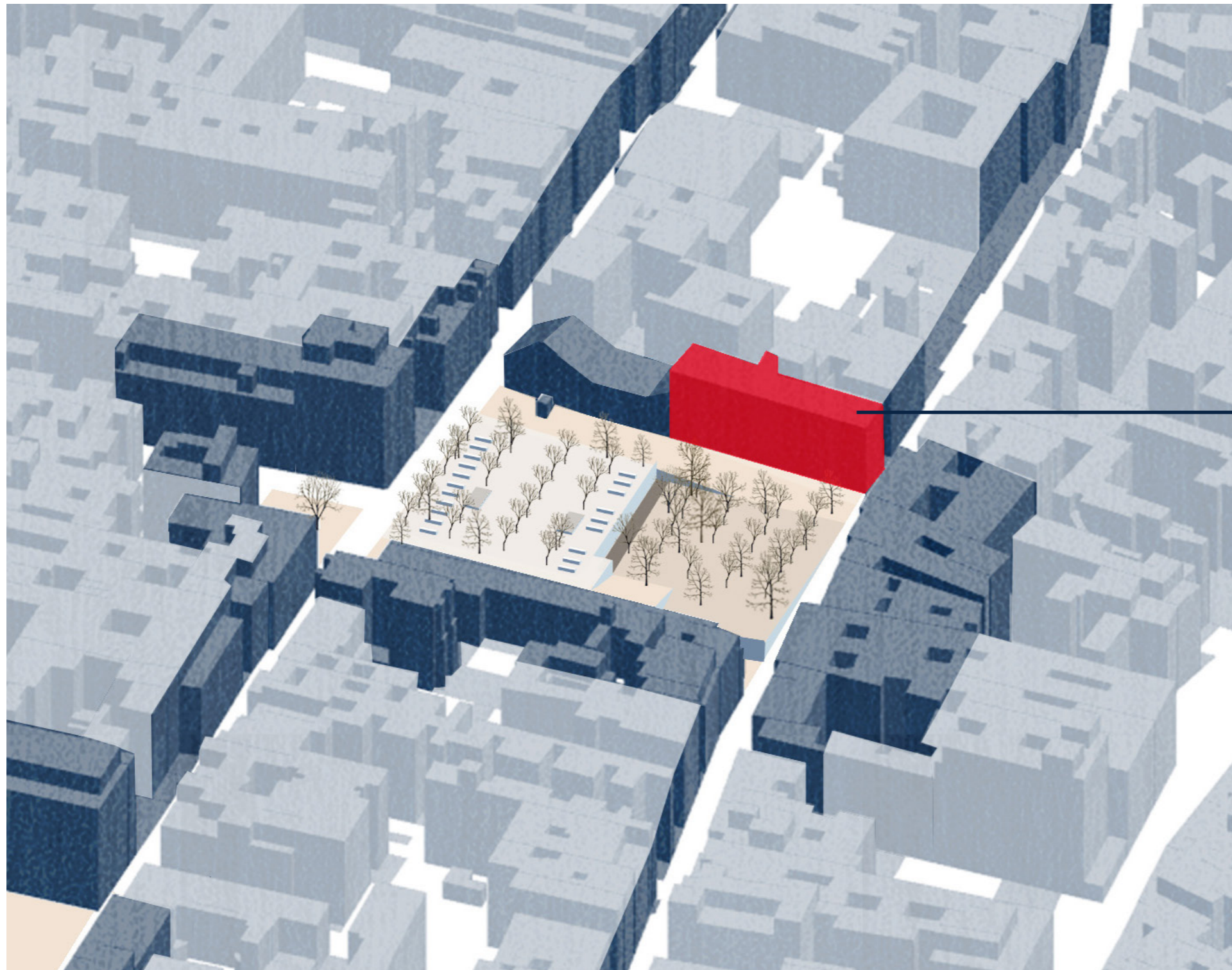

La Quimera



# Towards Open Third Space

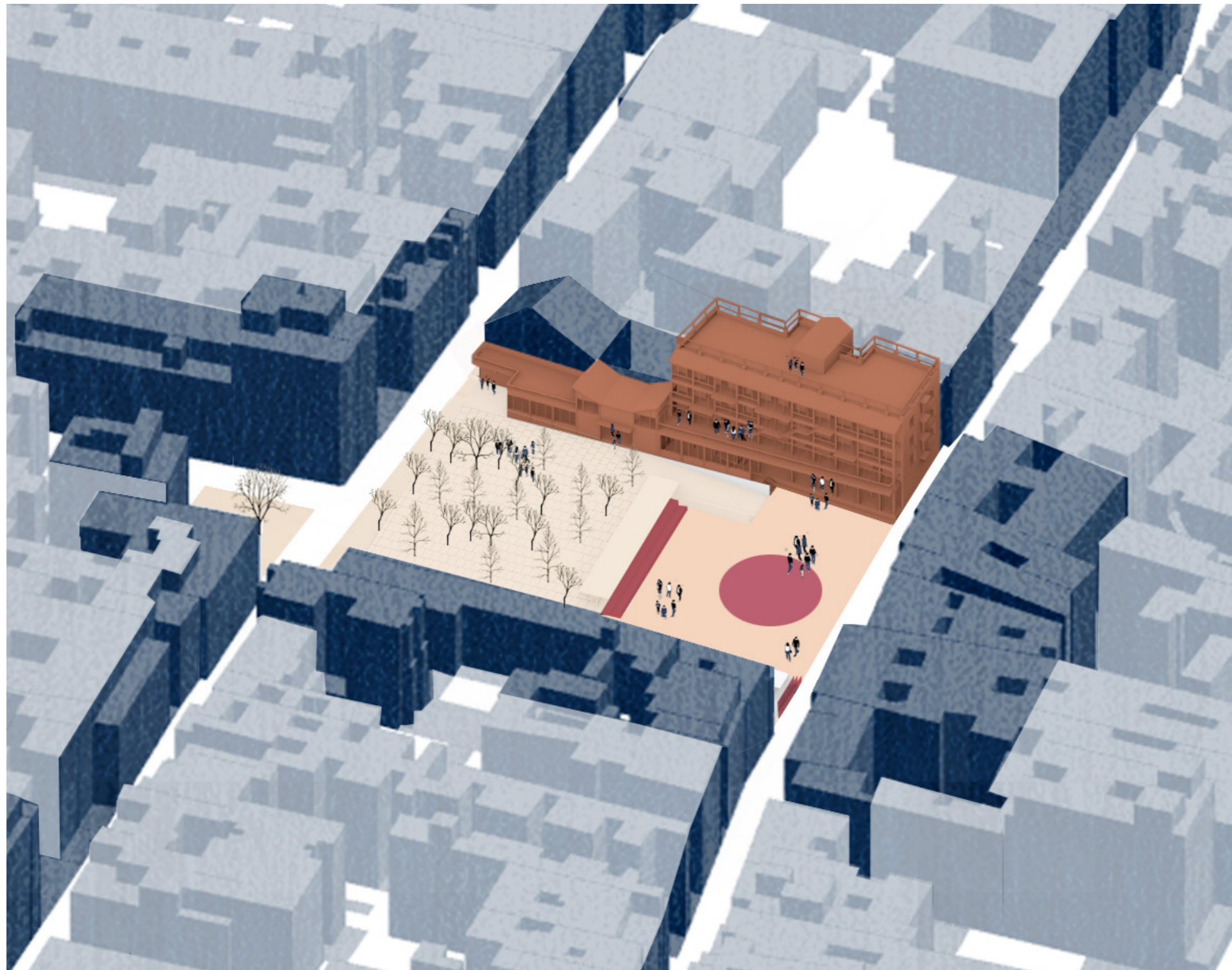



# A hub for activating the square

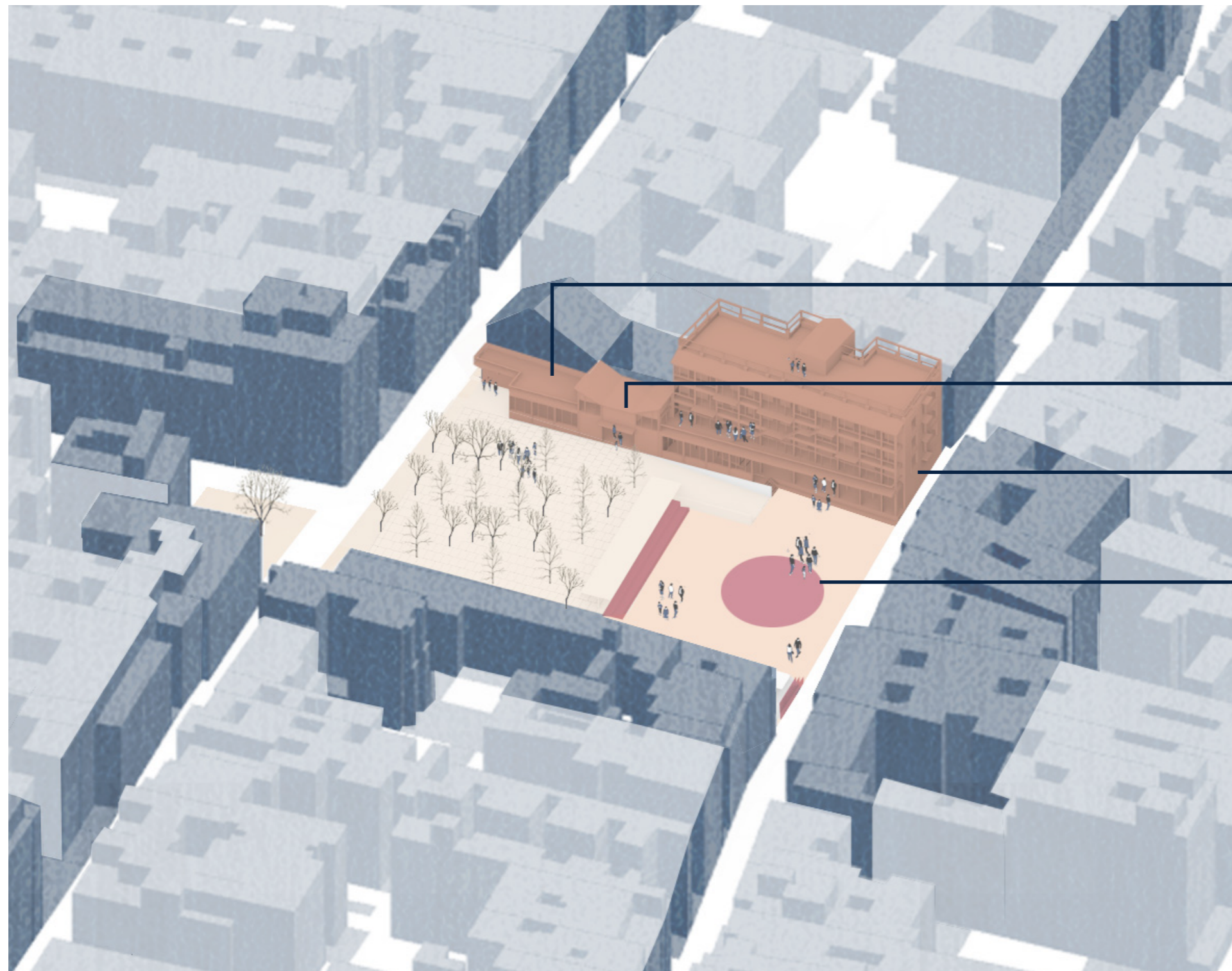

Workshop

Shared entrance and library

Newcomer Housing

Re-programmed square

Focus on creating spaces of belonging and encounter for diverse inhabitants



# Light-touch envelope concept

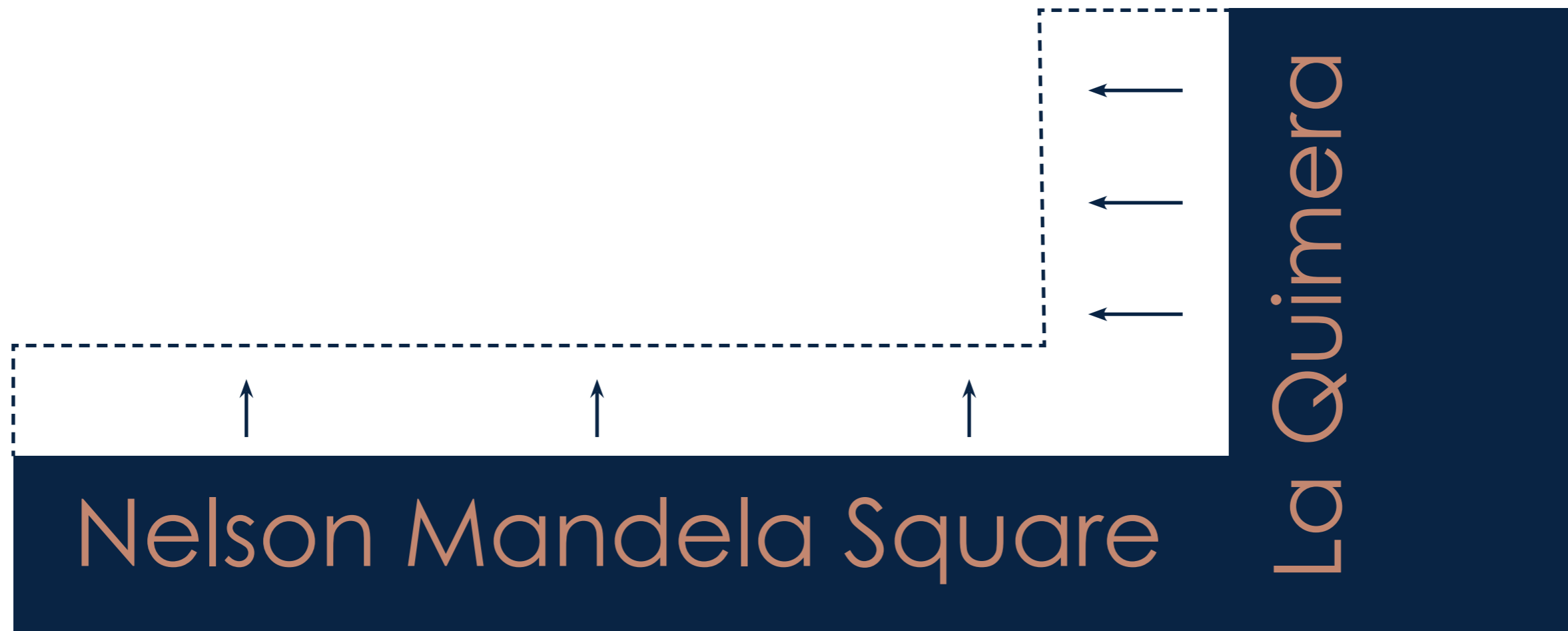



# Building from La Quimera

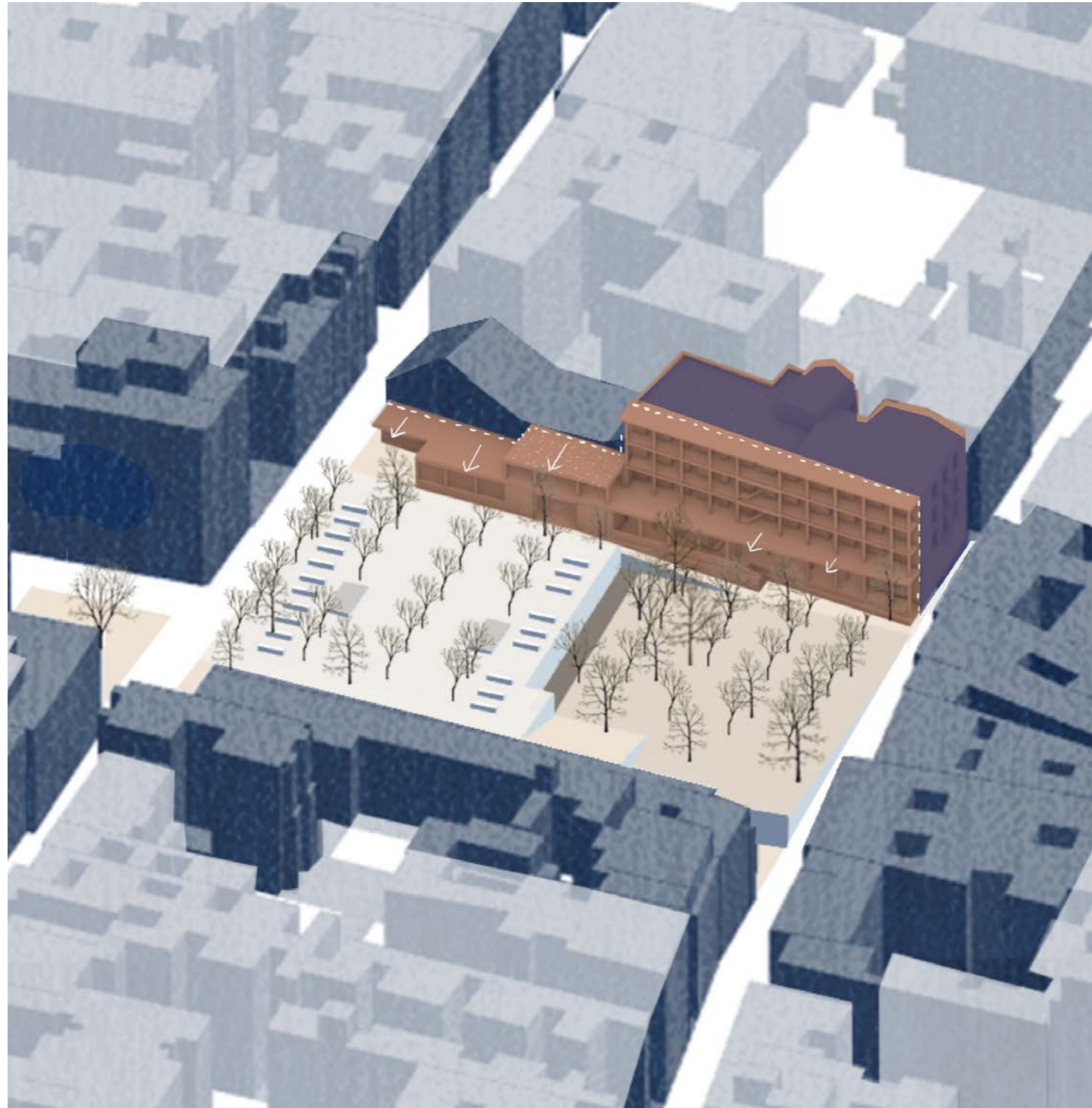



# Building up from the Car Park

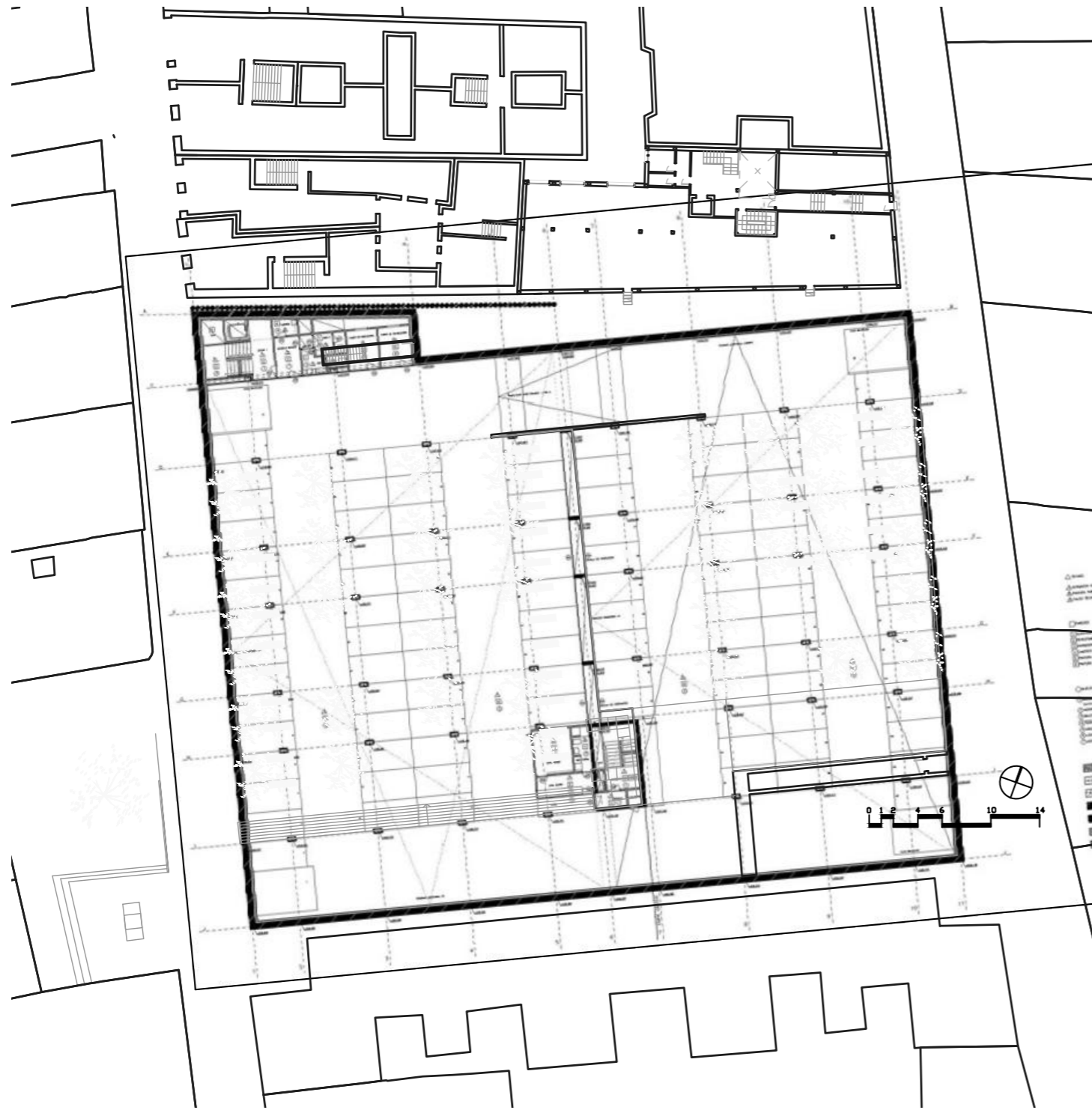



# Building around the Car Park

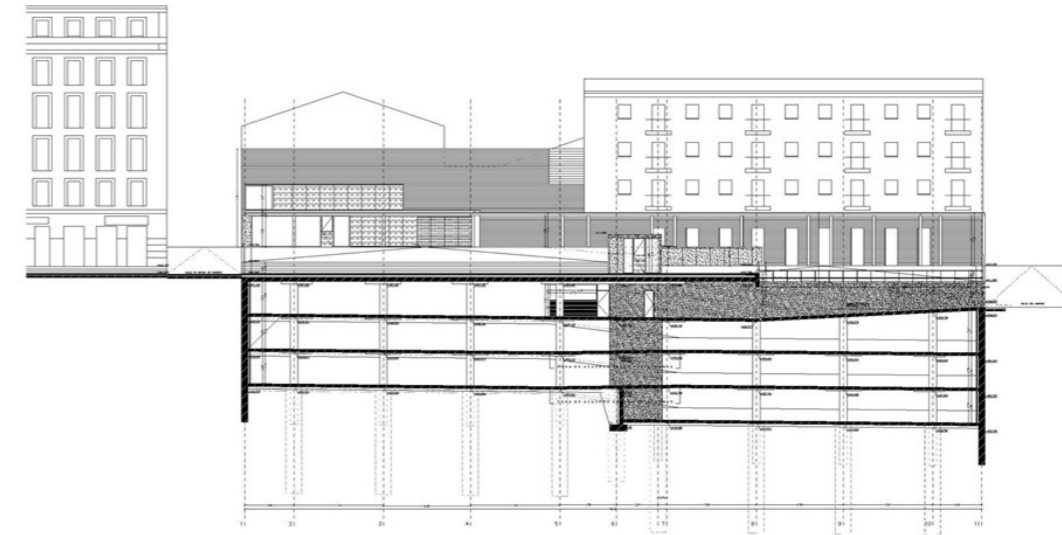
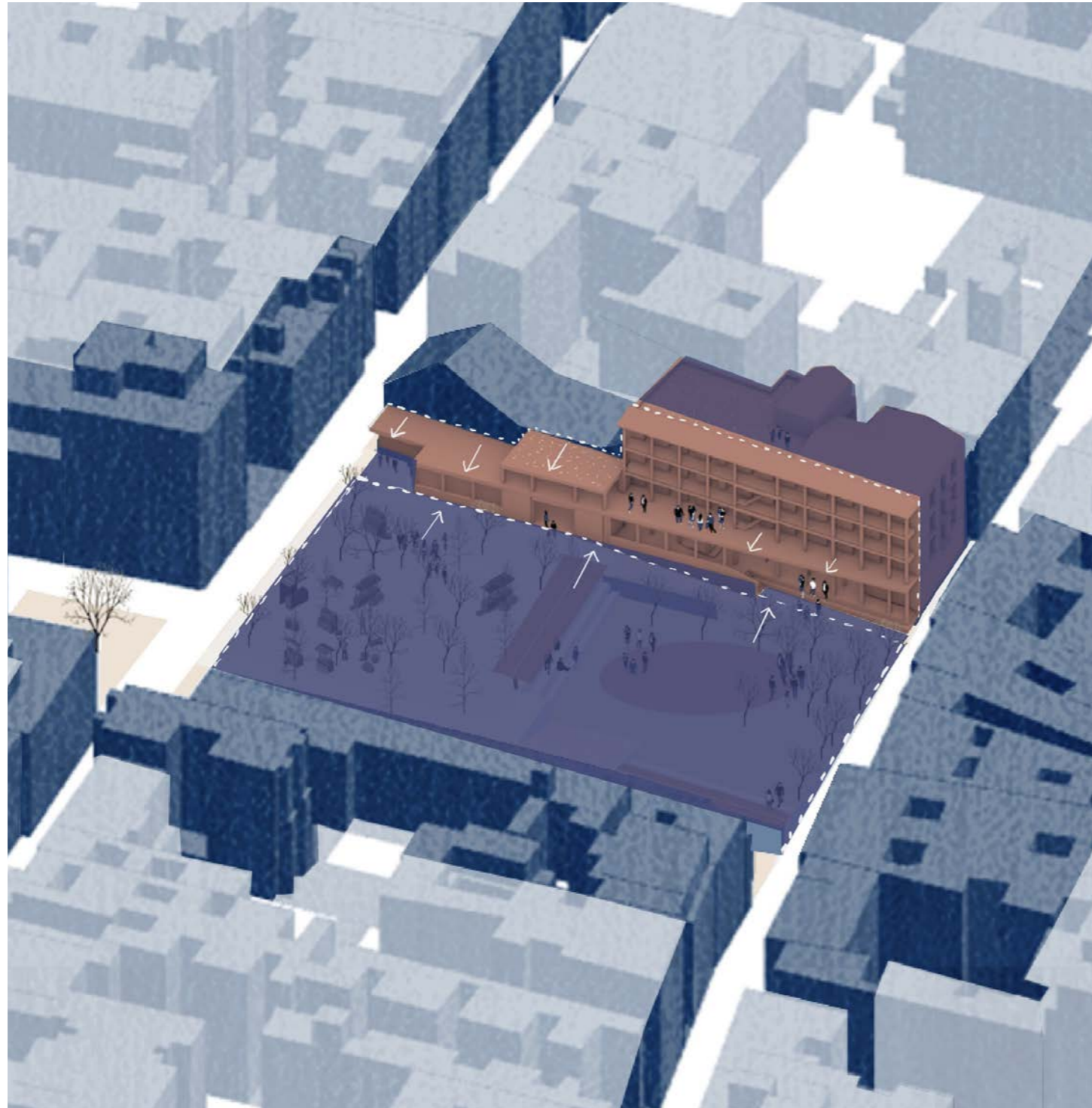



# Existing Structure

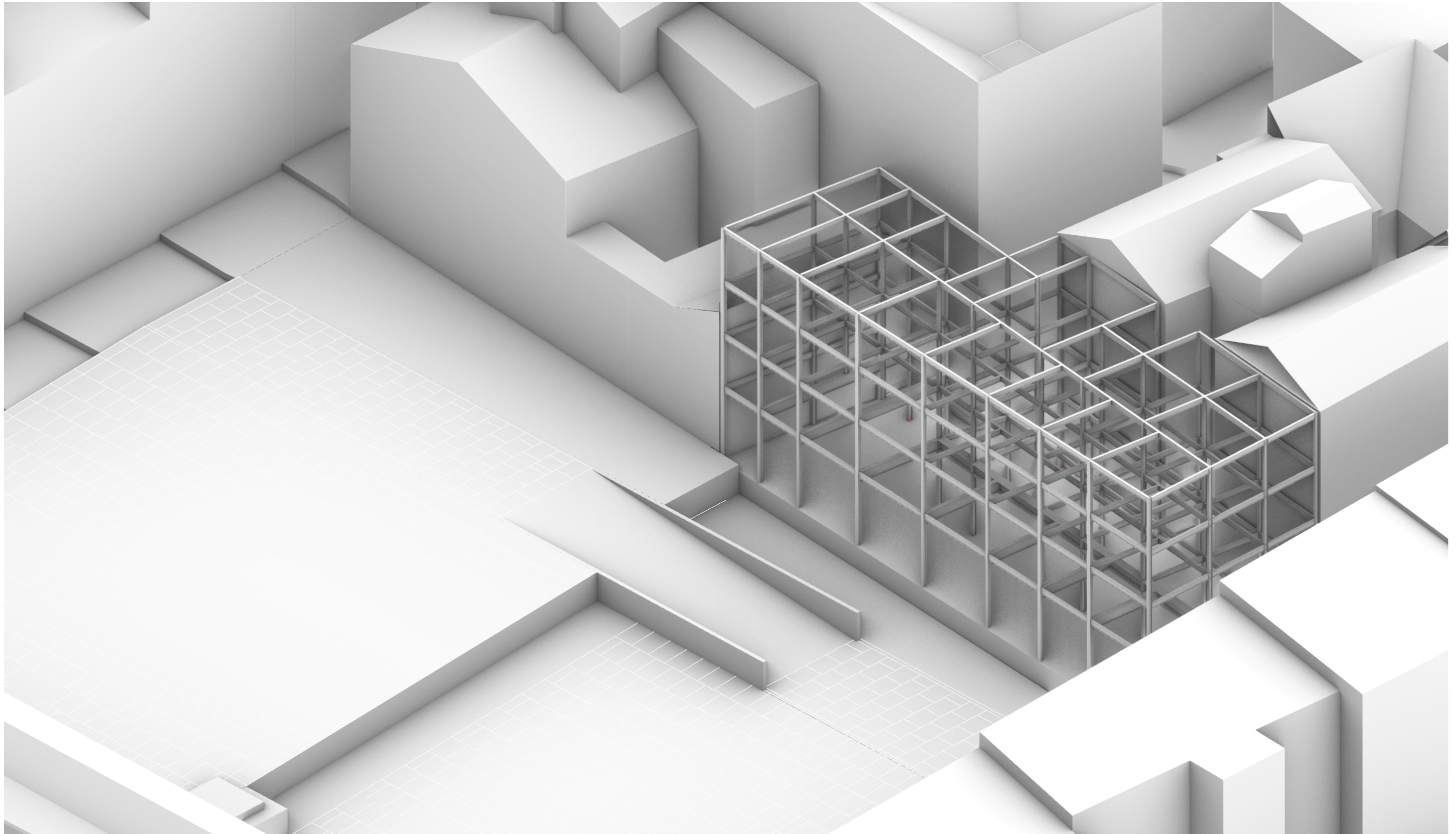



# Existing Structure

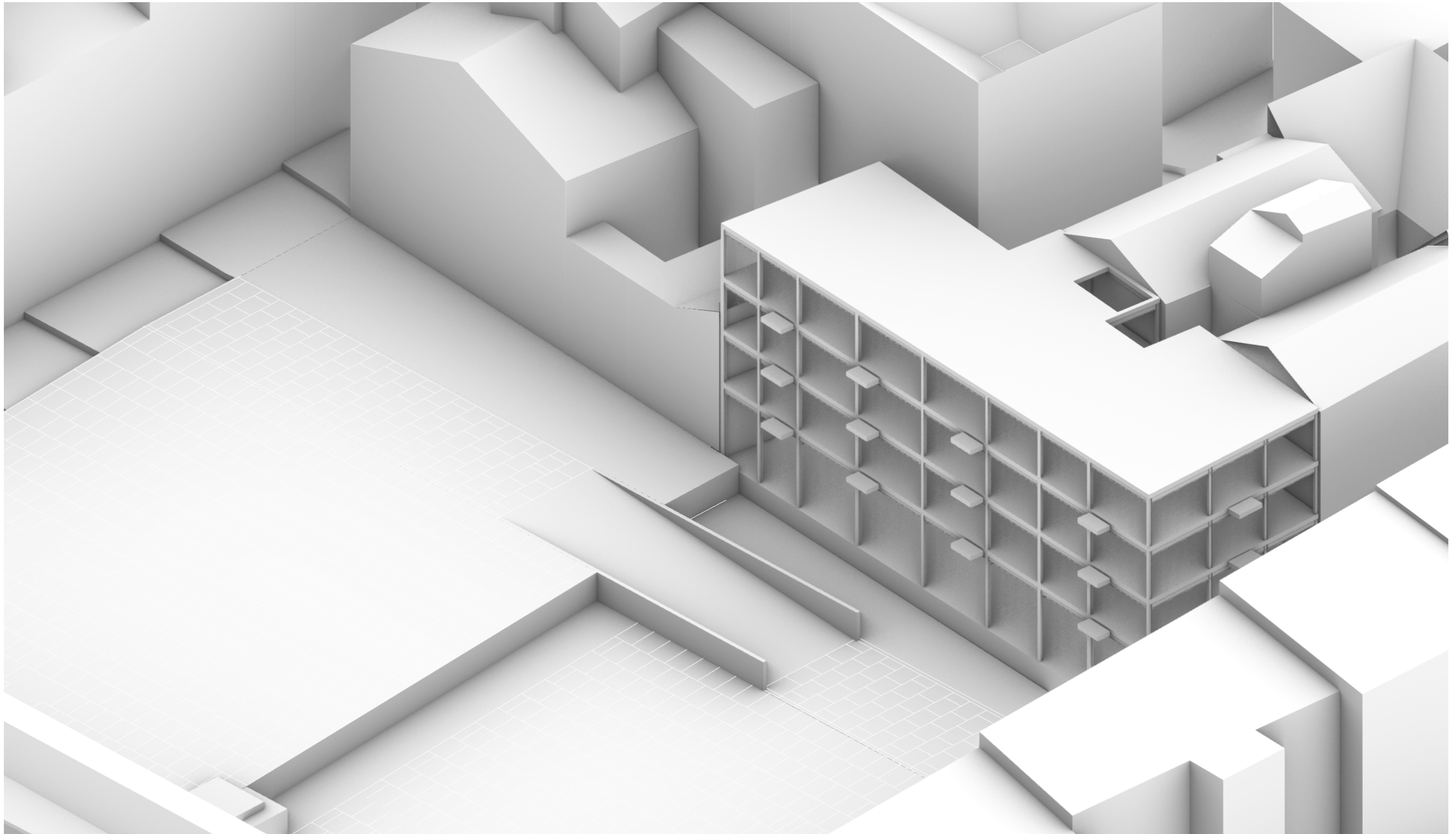



# Existing Structure

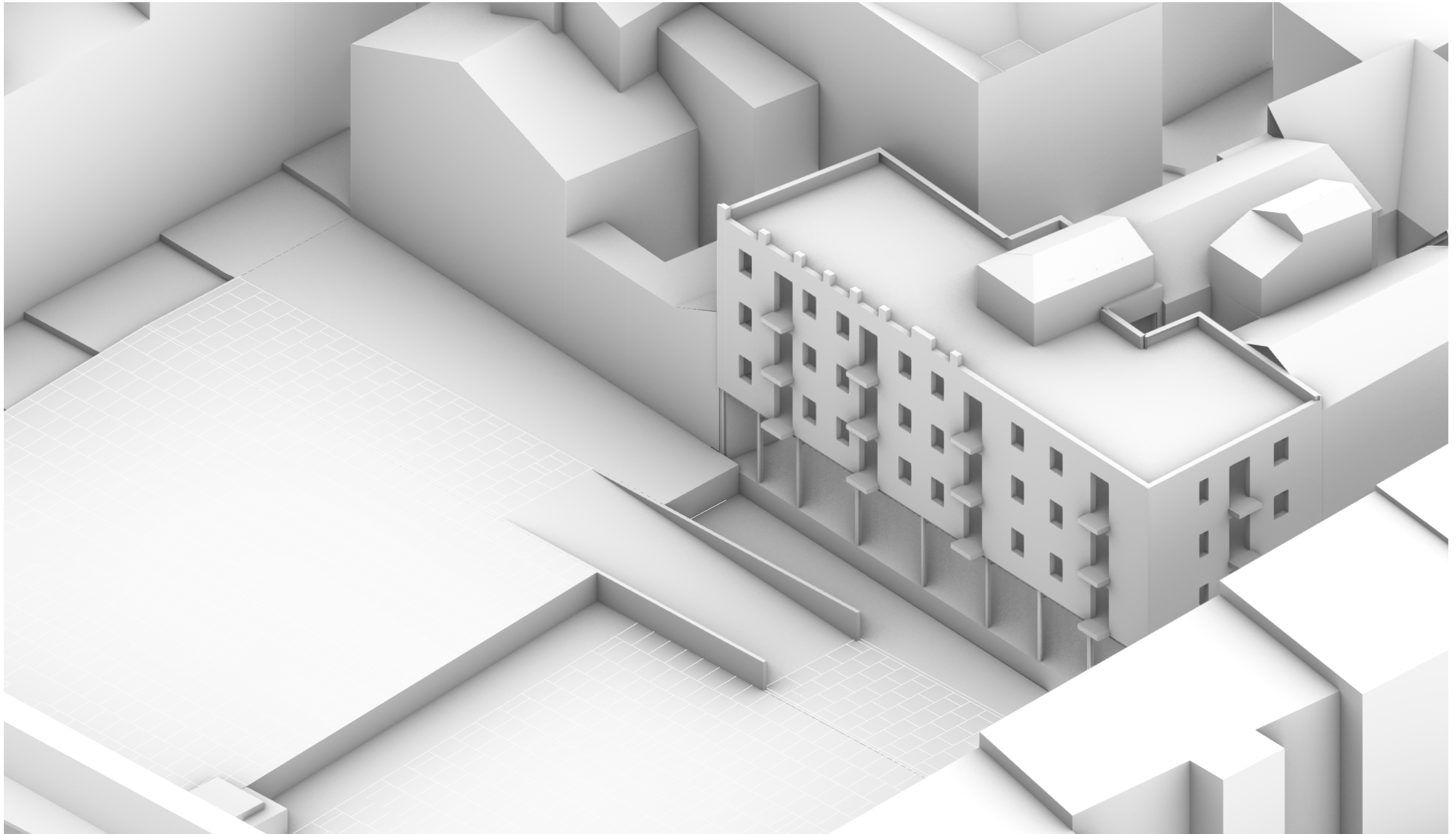



# Foundations

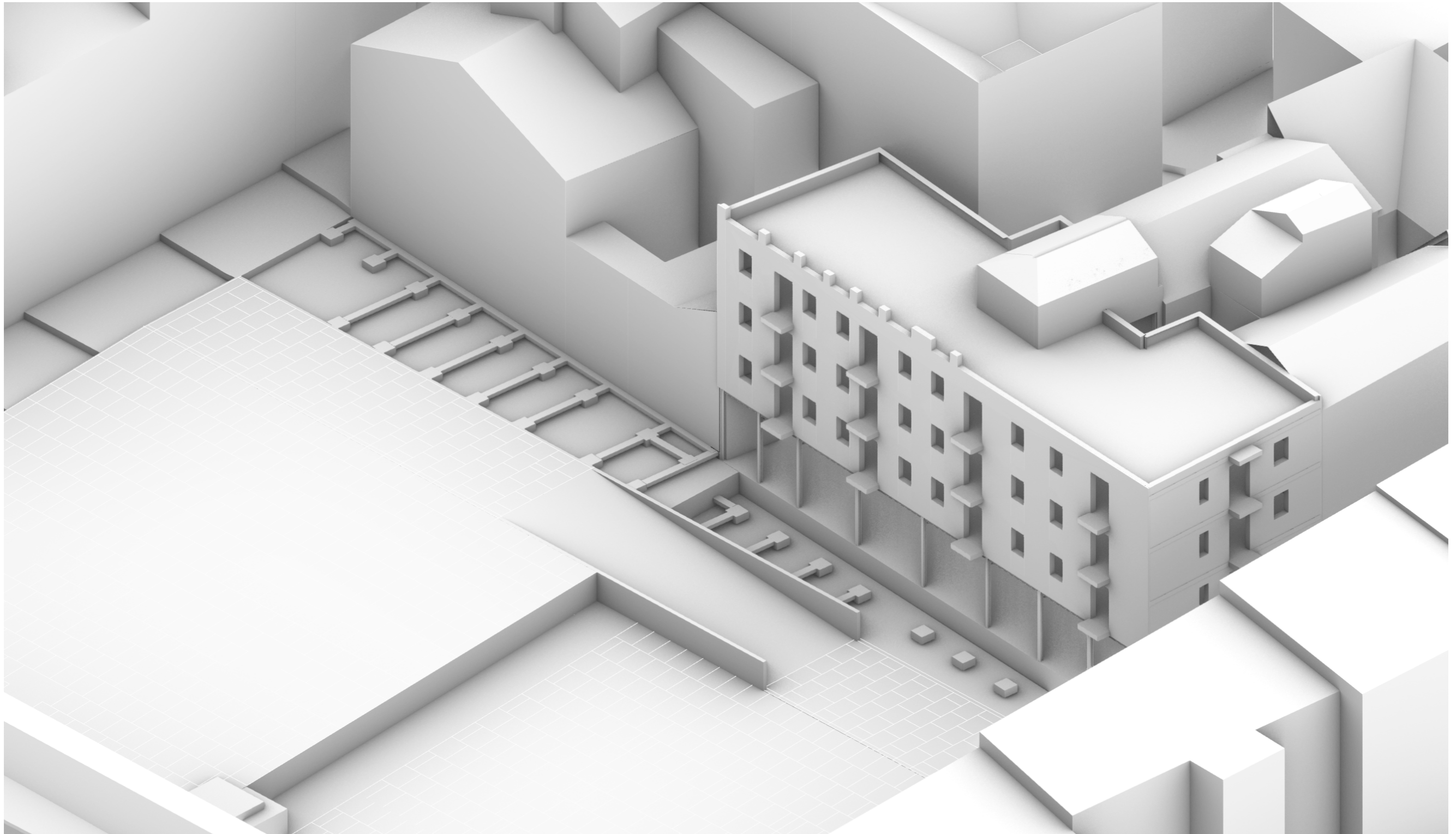



# Glulam Structure

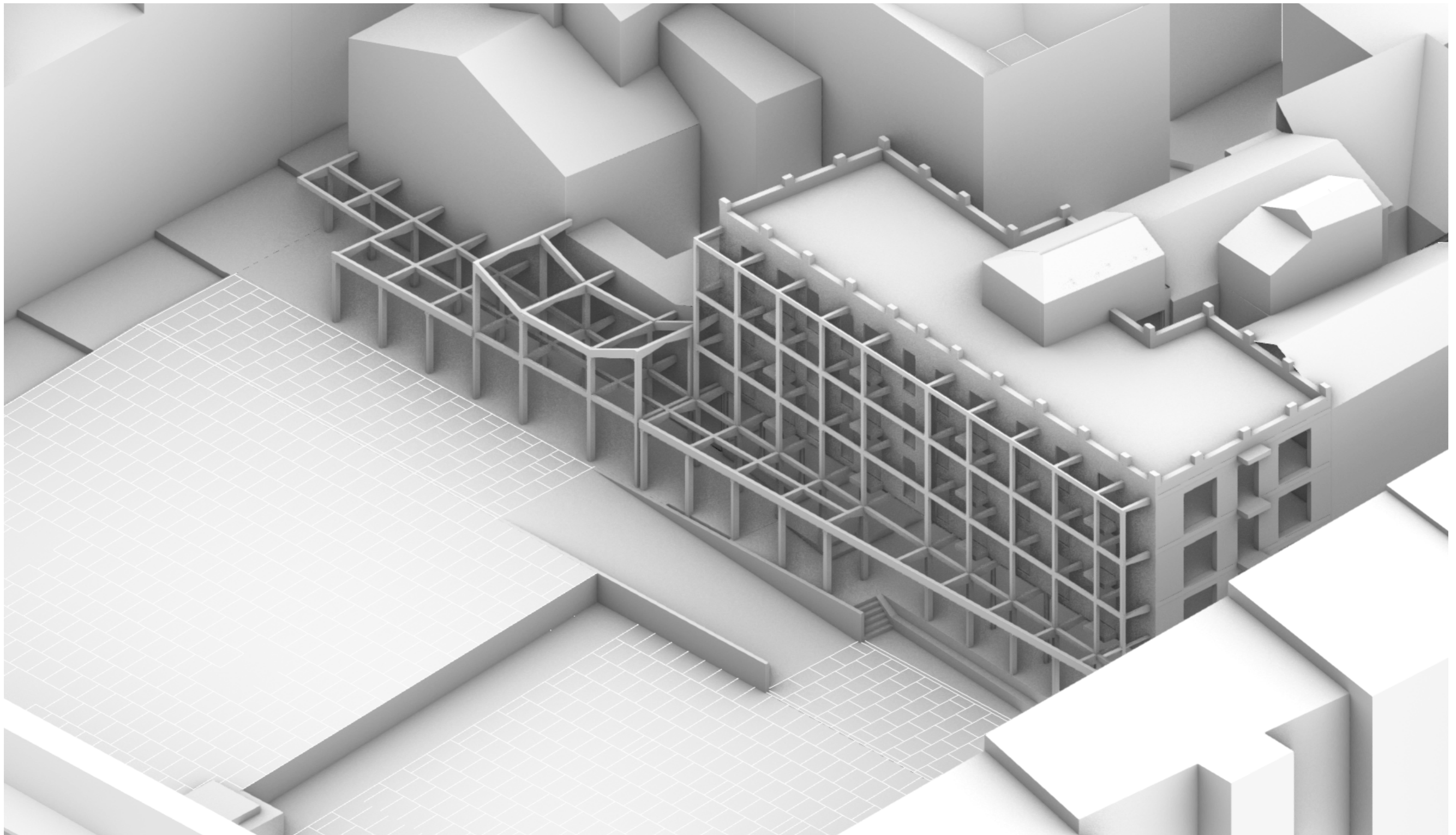



# Slot into the Existing

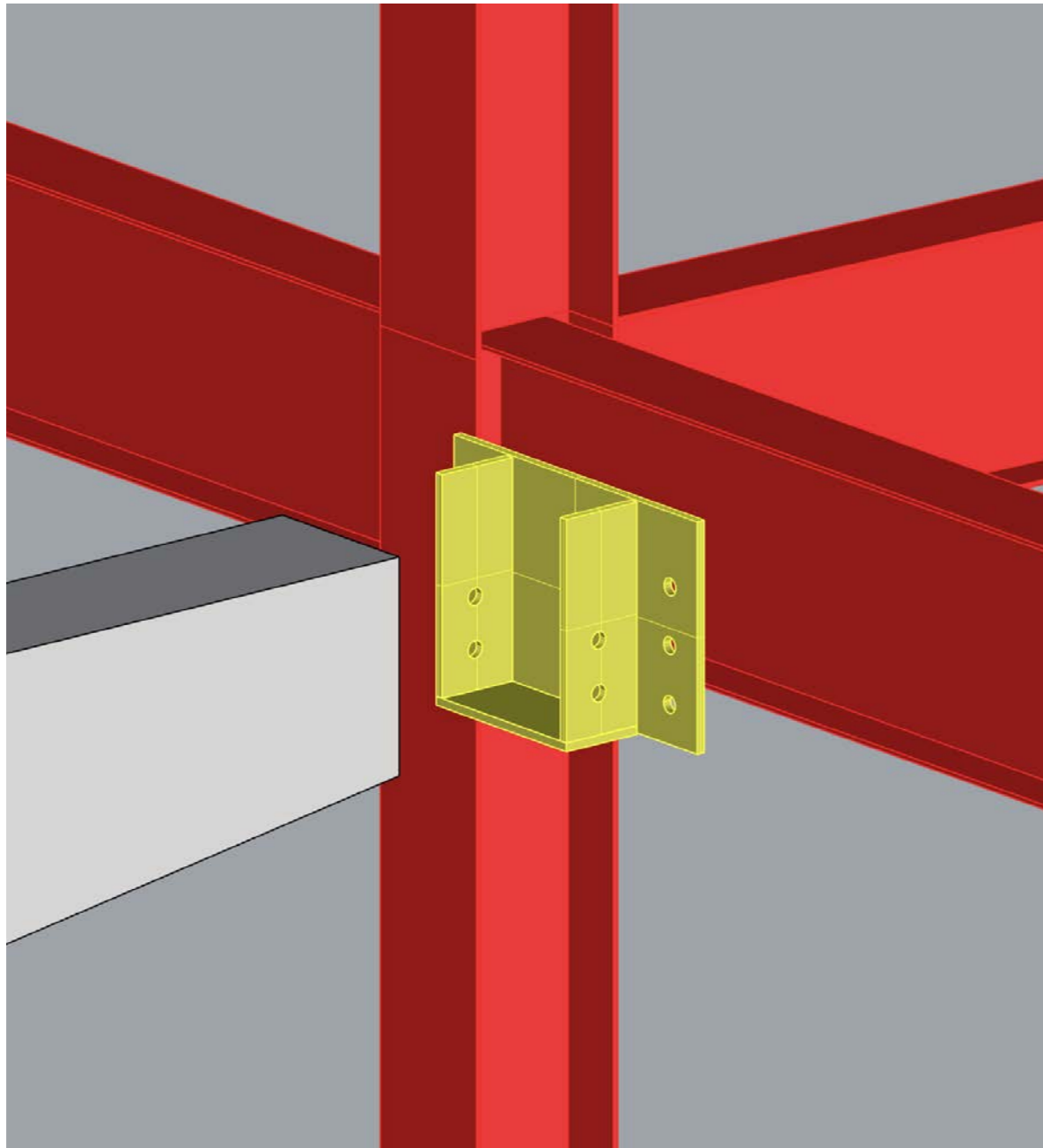



# Column to Beam Axo

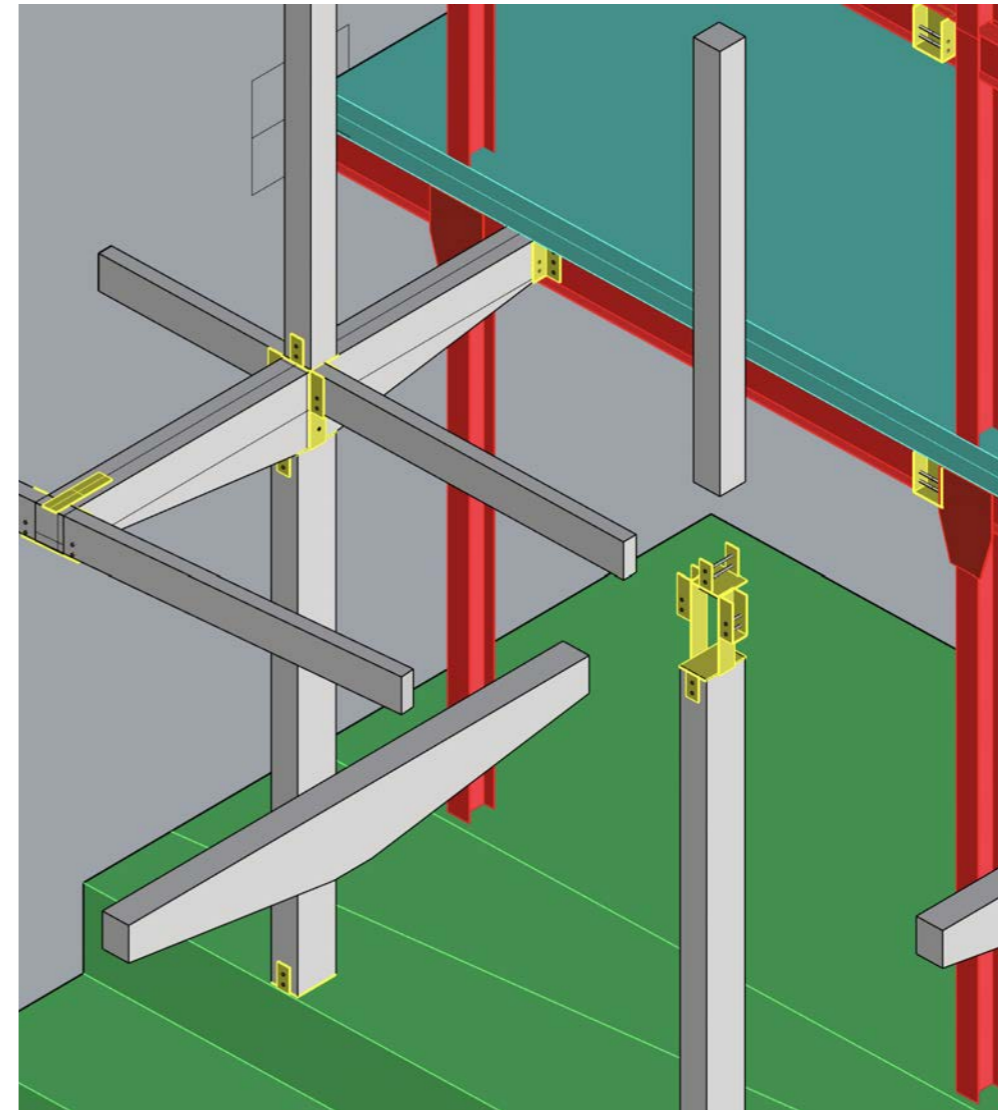
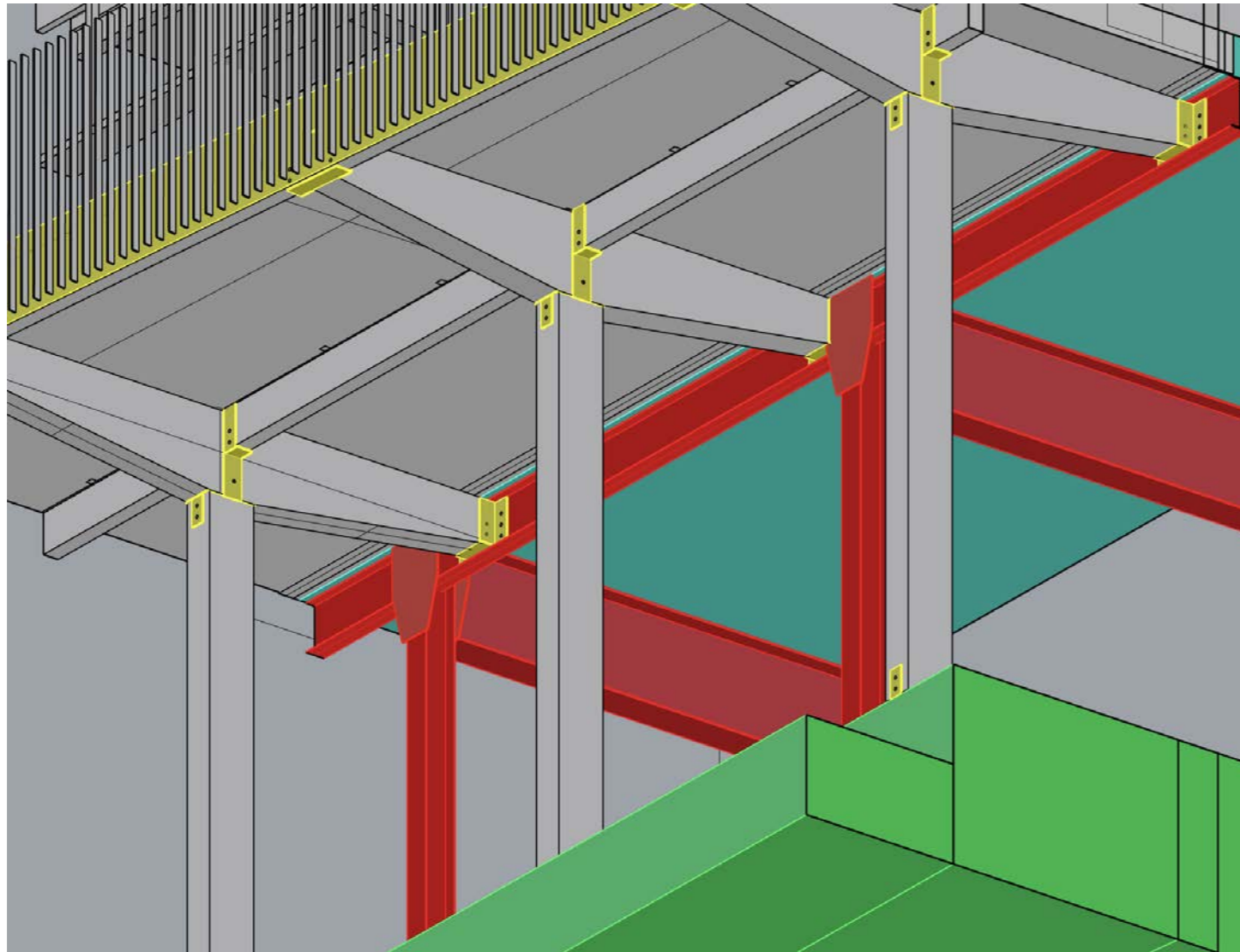



# Glulam Structure

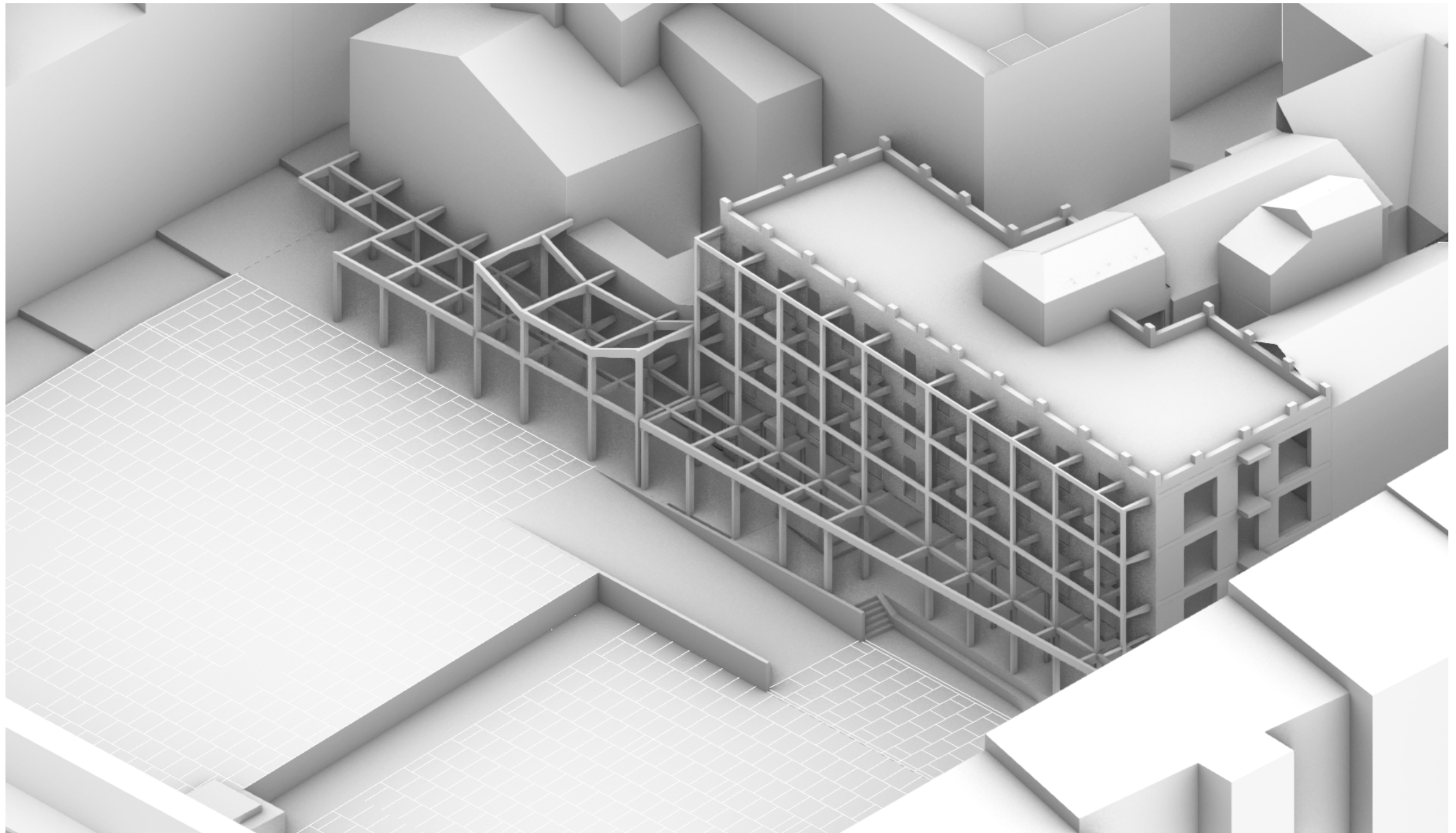



# Lateral Stability

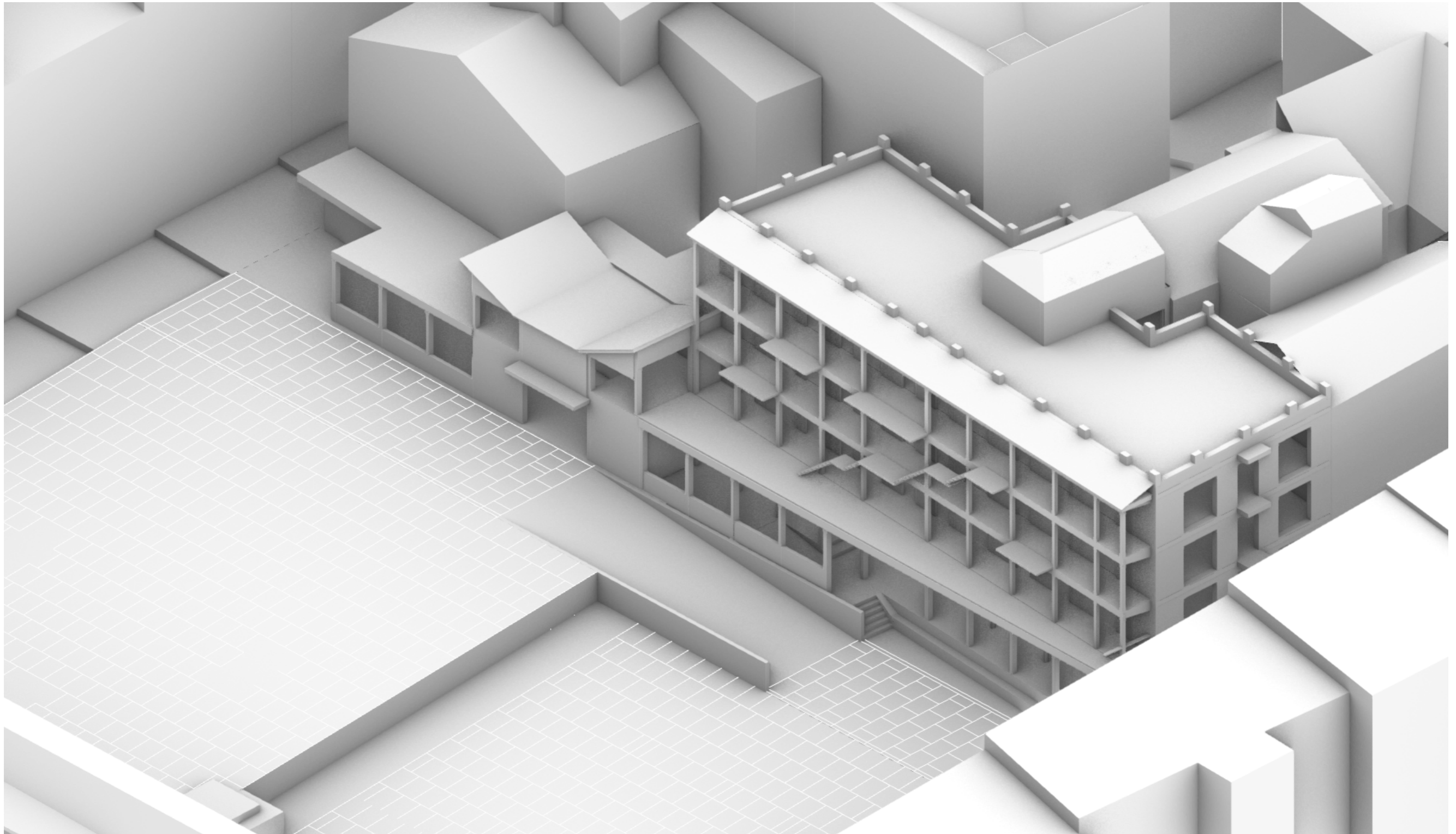



# Mixed Programming

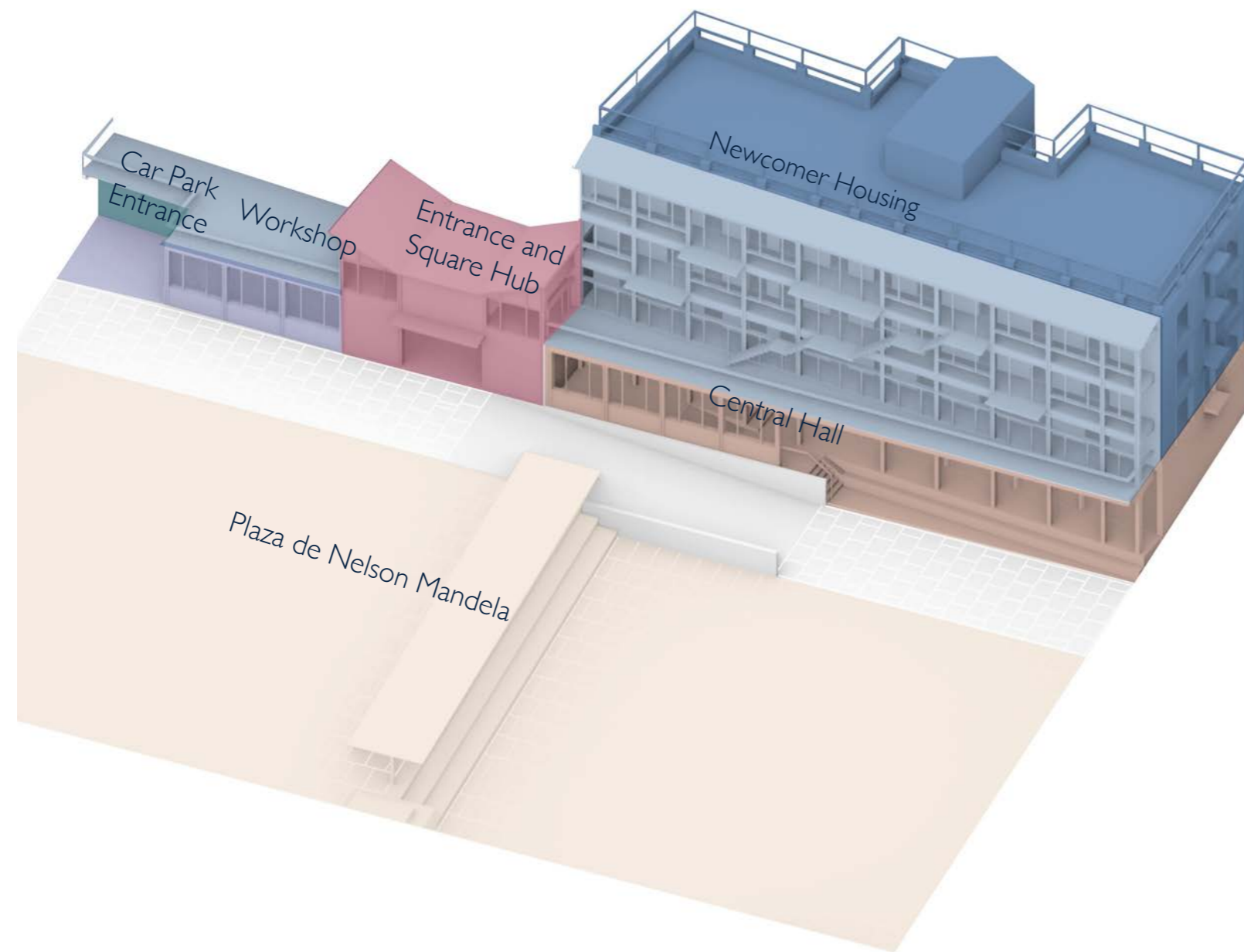



# Mixing user groups across thresholds

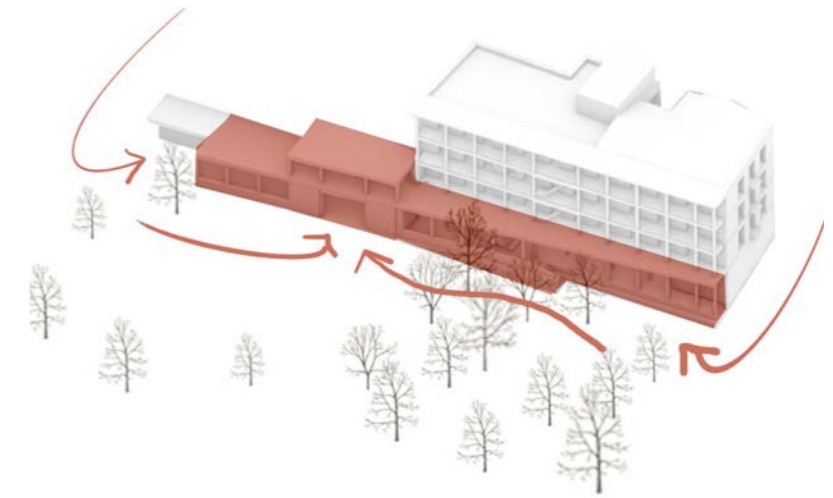



# Mixing user groups across thresholds

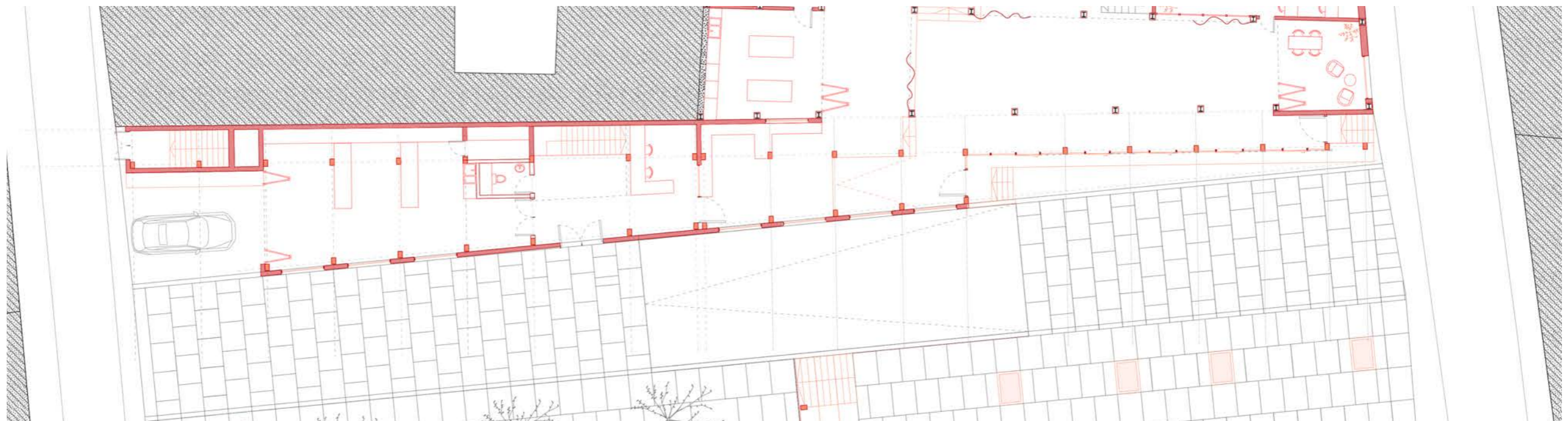



# Connecting the square

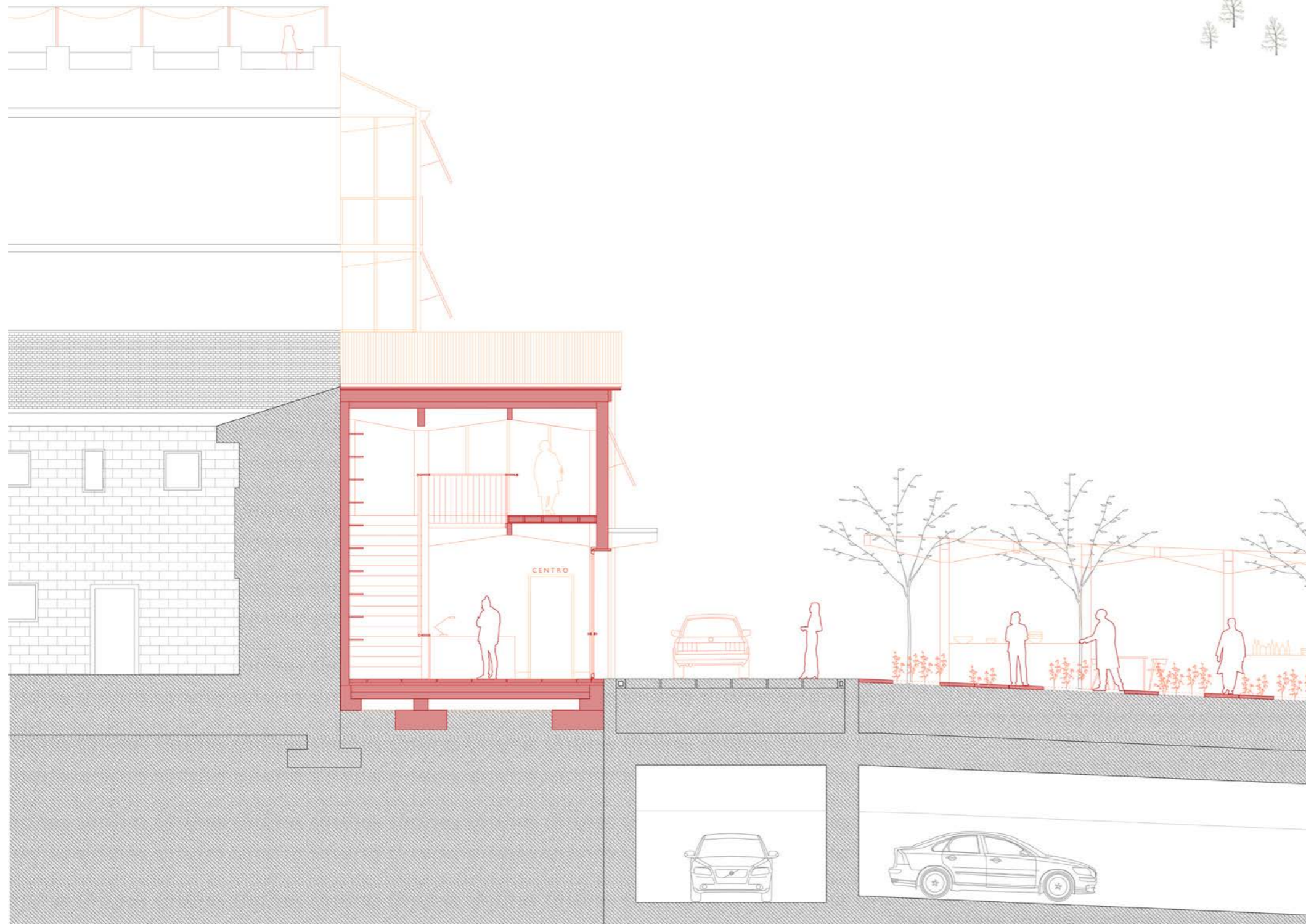
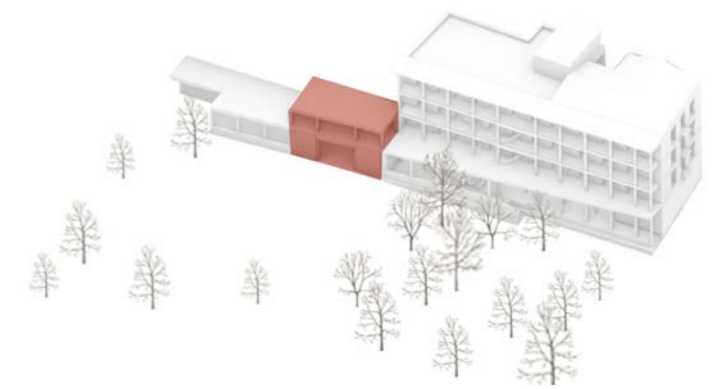



# Building into the Ramp

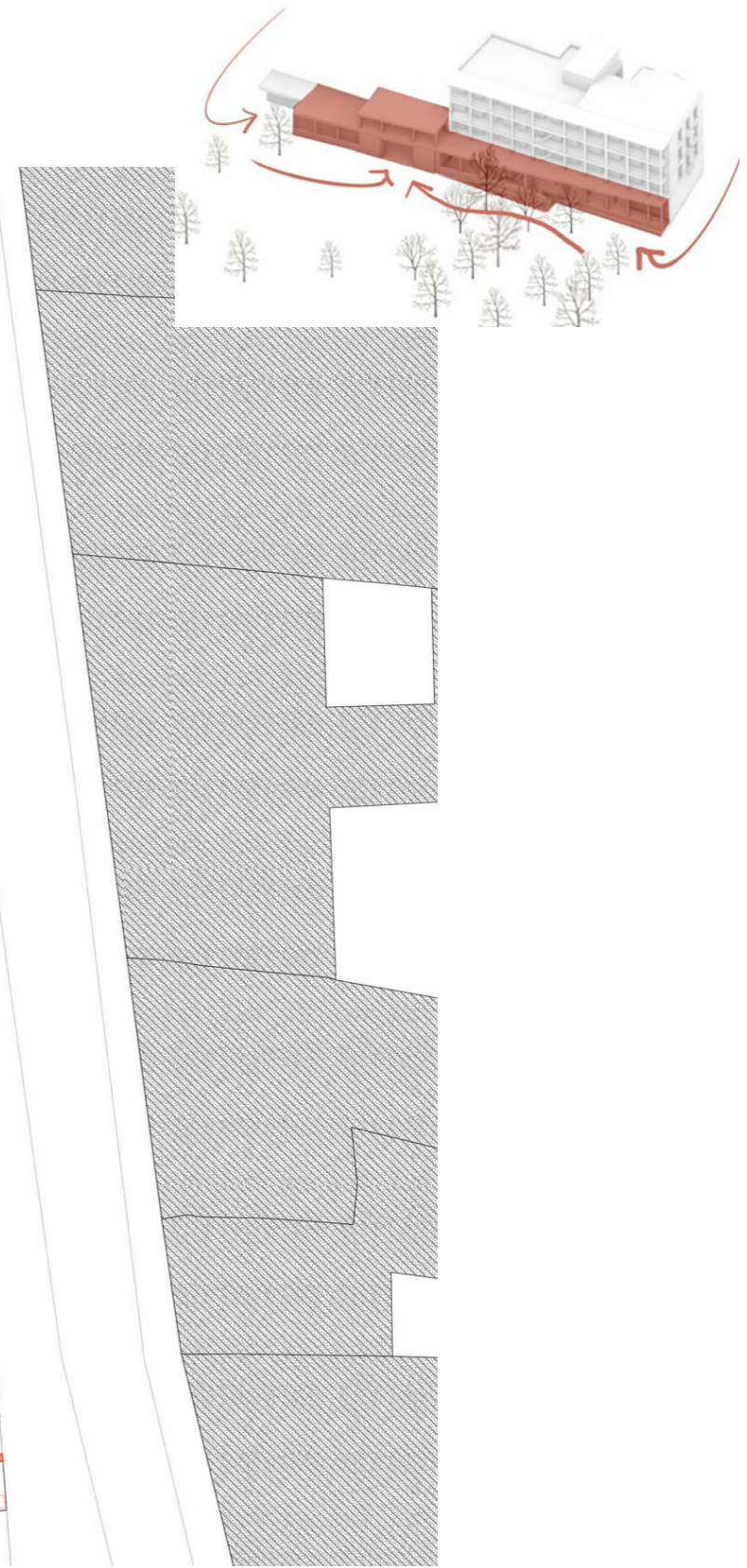
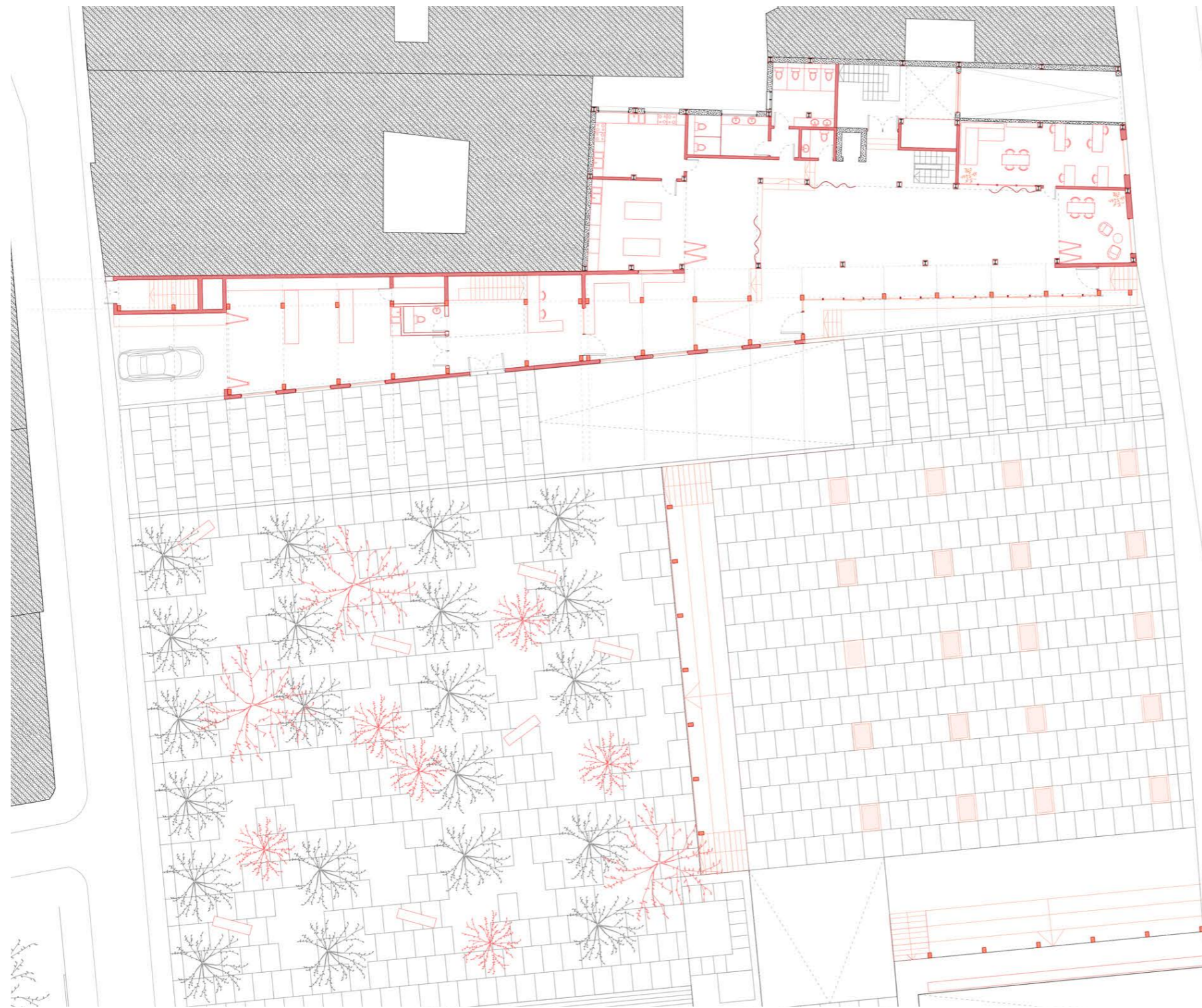



# Central Hall

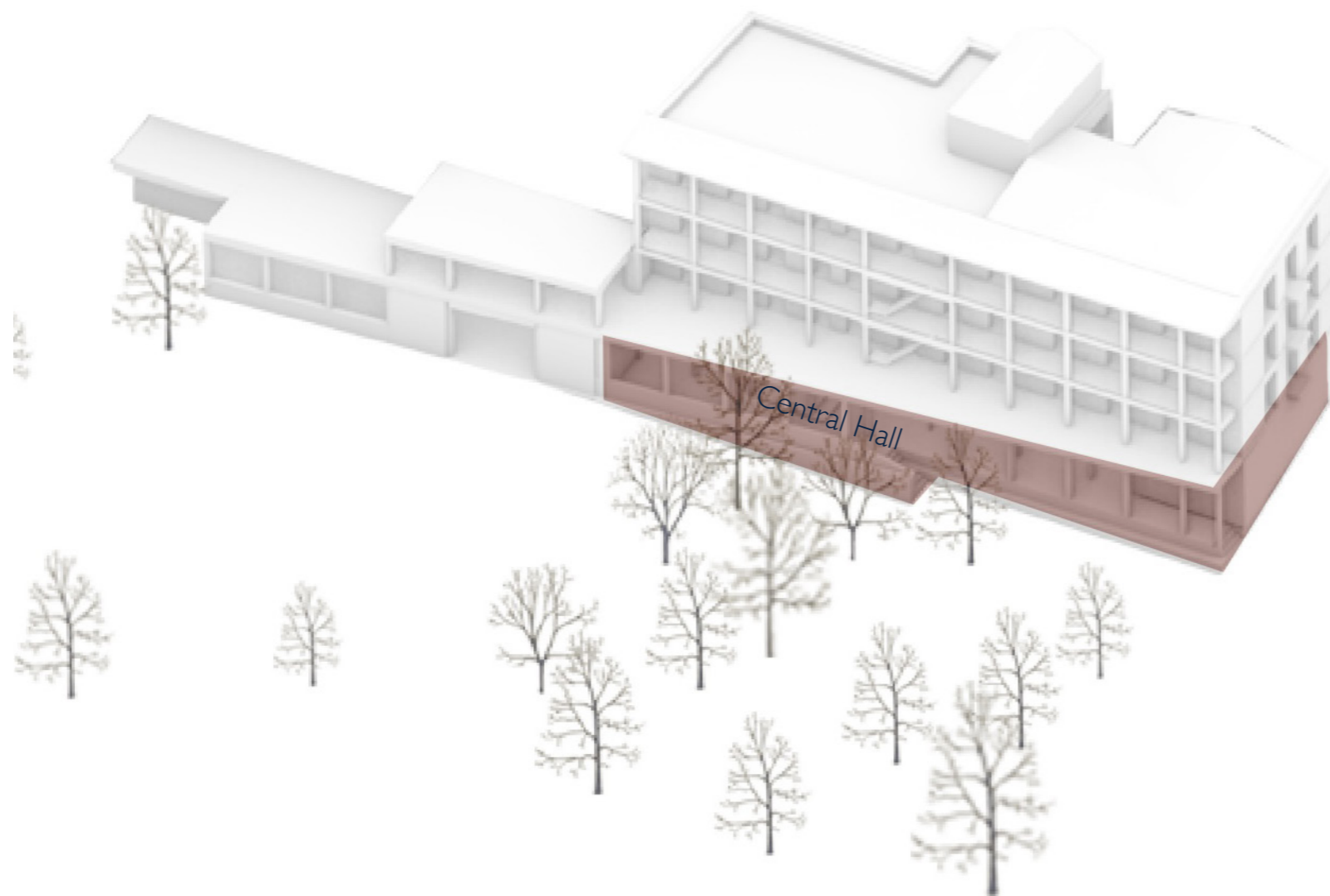



# An adaptable open space

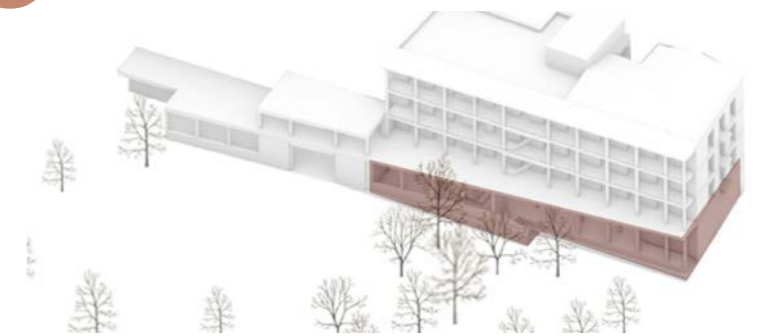

Ground floor during occupation



Closed ground facade

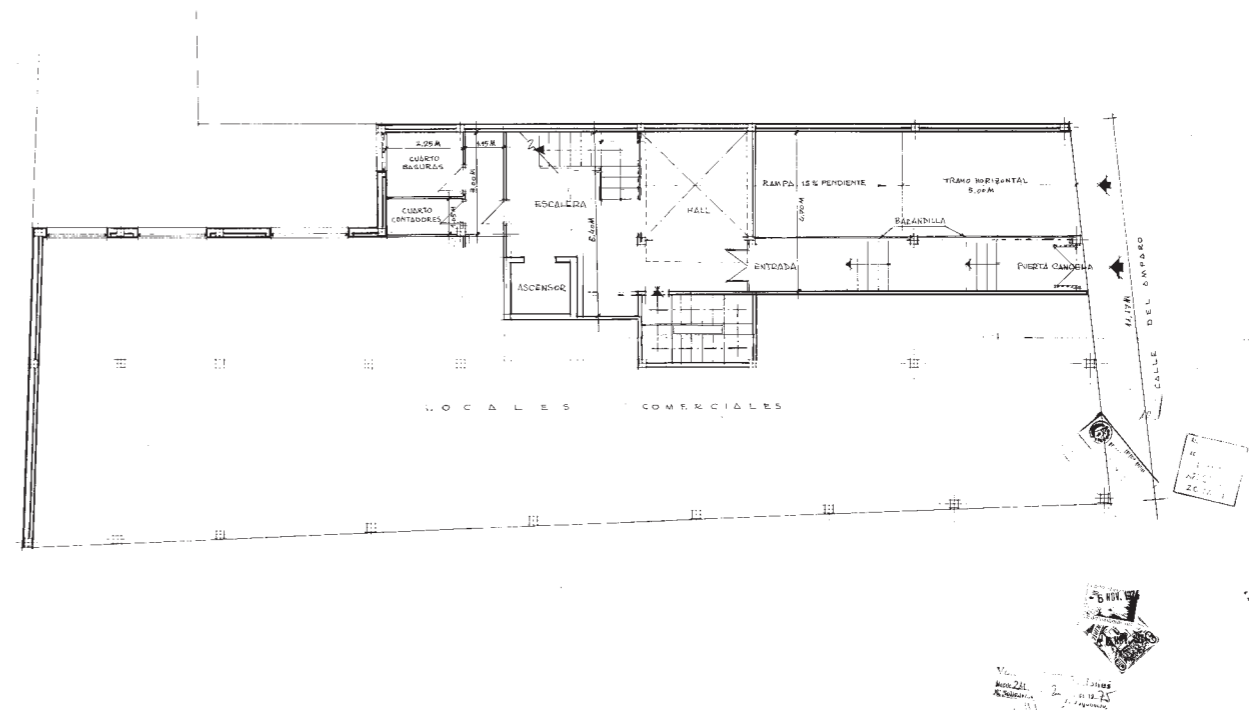

Ground floor in original architect's drawings



# Celebrating temporal thresholds



A more open connection with the square, celebrating old and new





# A backbone for the square

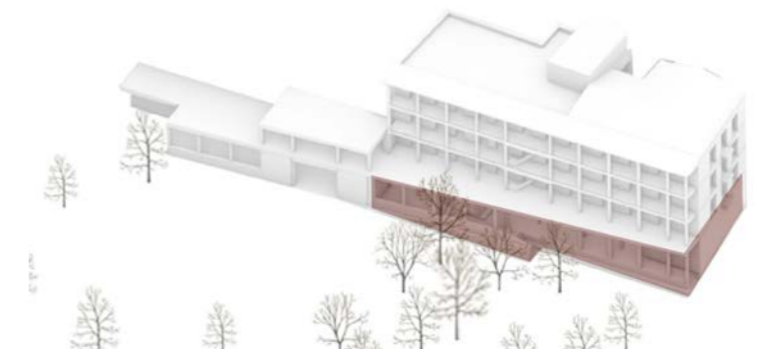

Kitchen, La Rueca (2023)



Main Room, Valiente Bangla (2023)



# Daily user adaptations

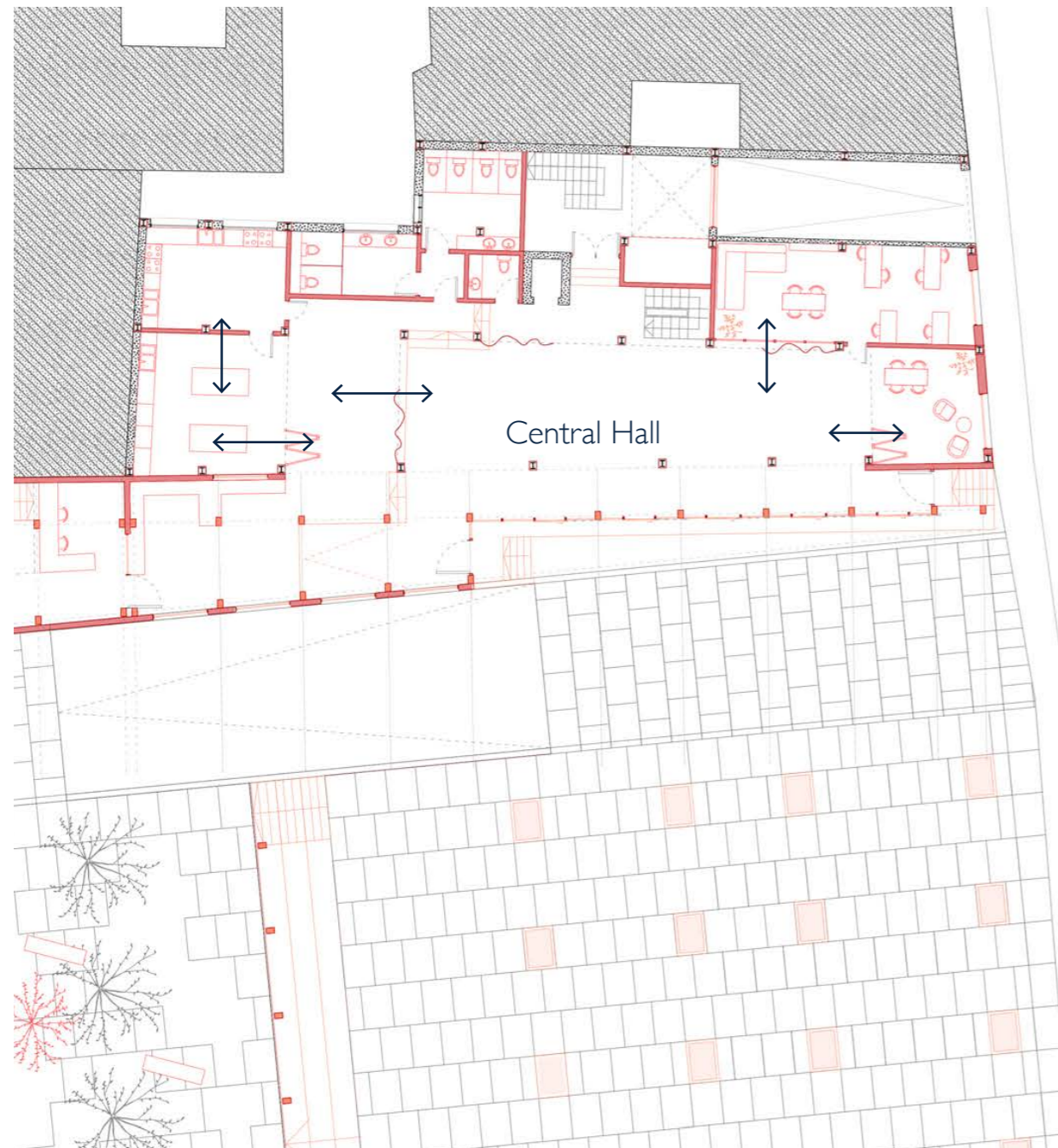
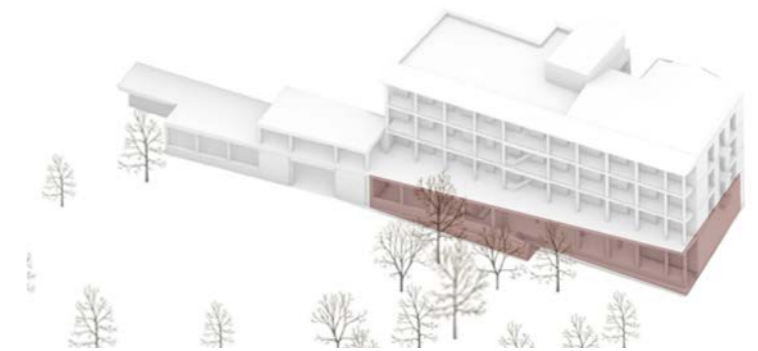







# Existing Private Flats

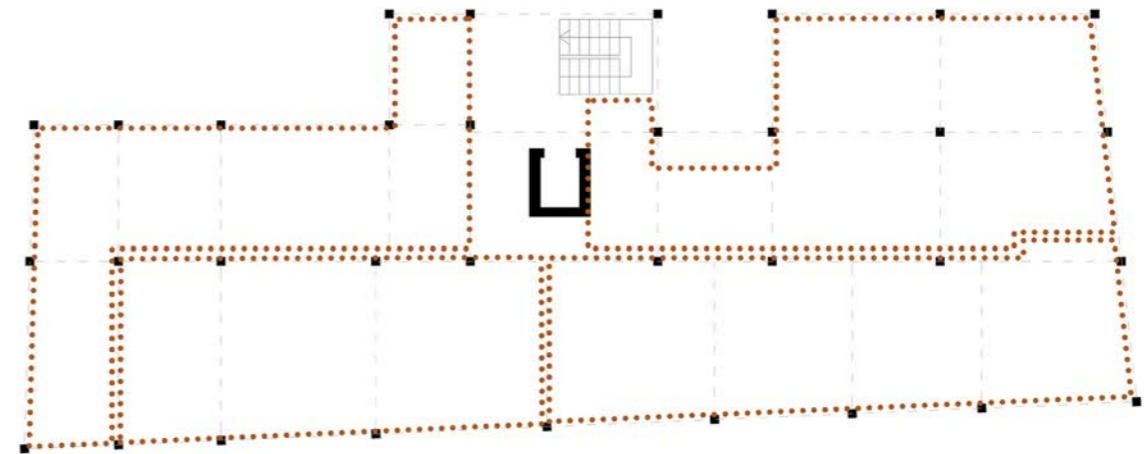
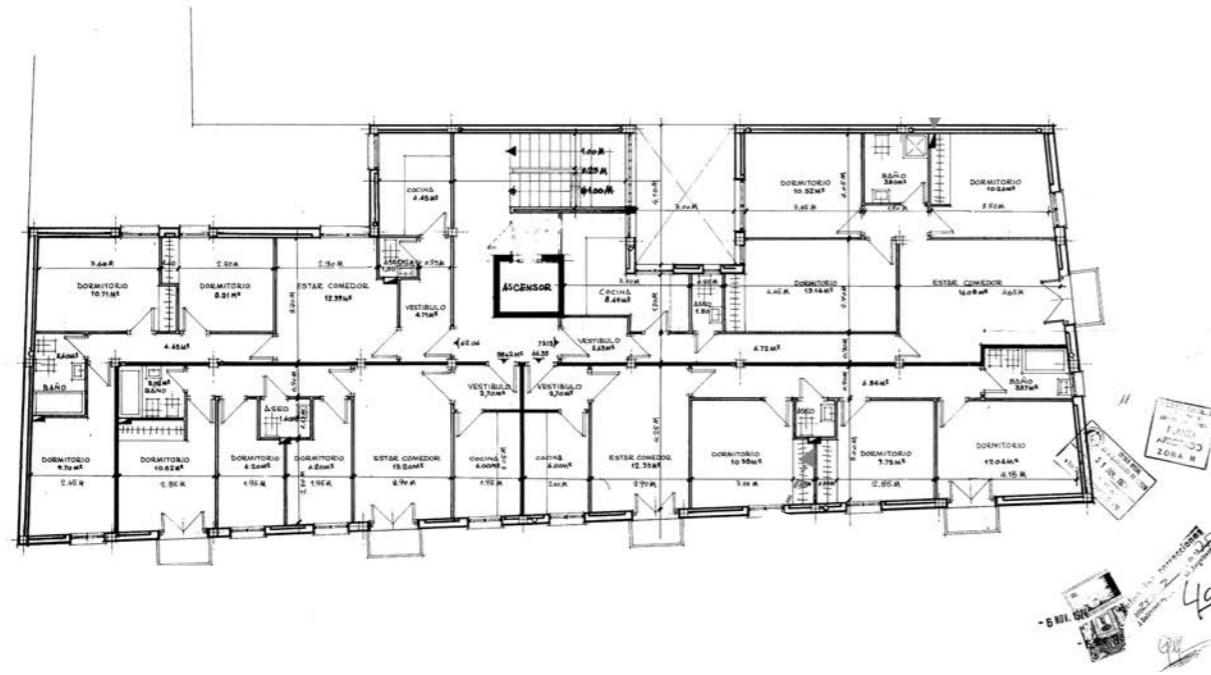



# Co-living for newcomers

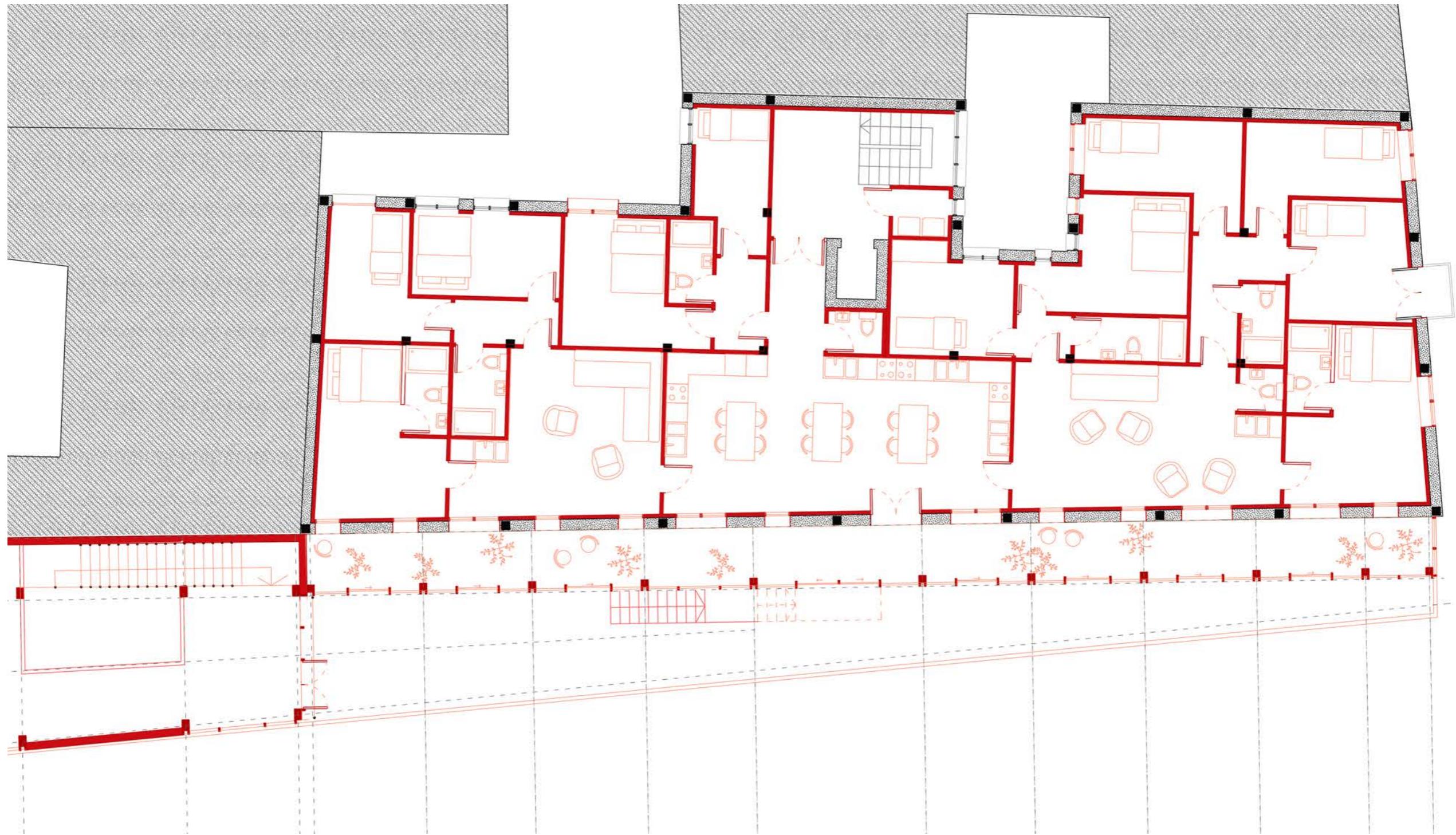



# Phases of Privacy

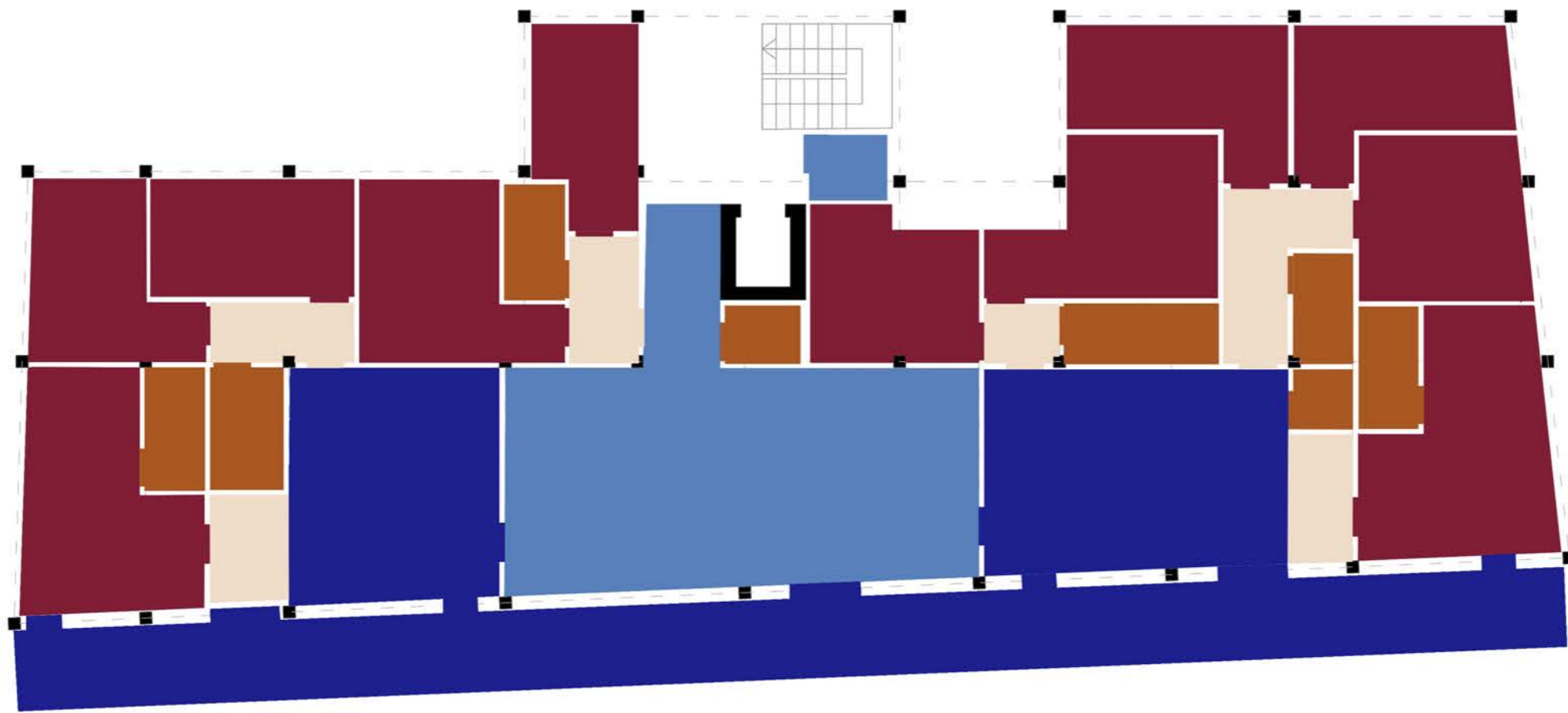



# Design for long-term adaptability





# Design for adaptability

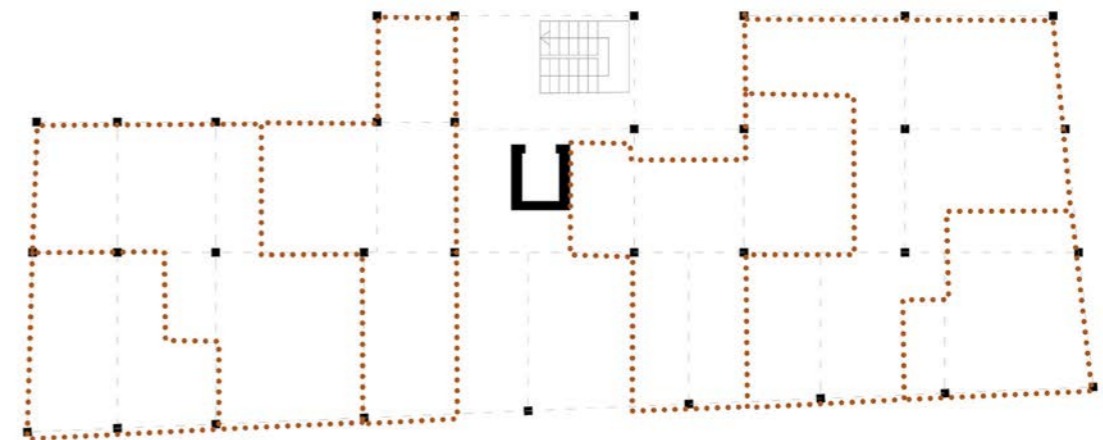
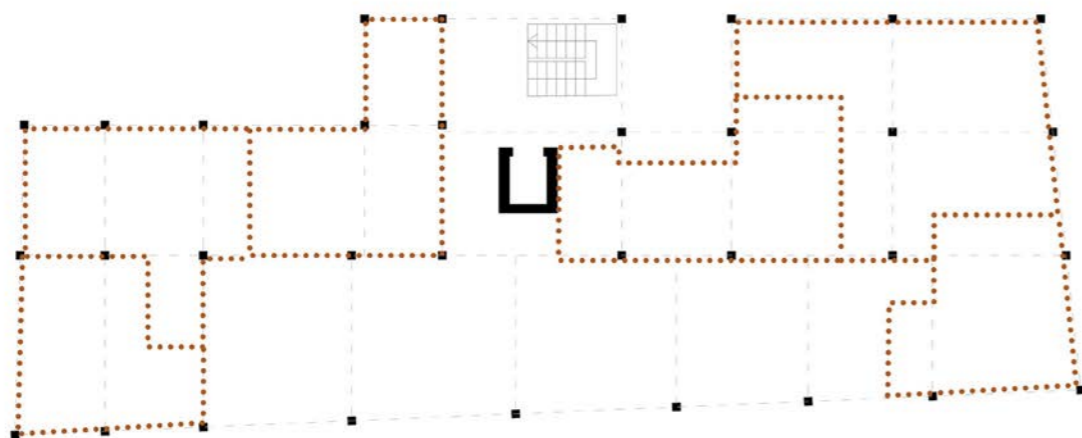



# Design for adaptability

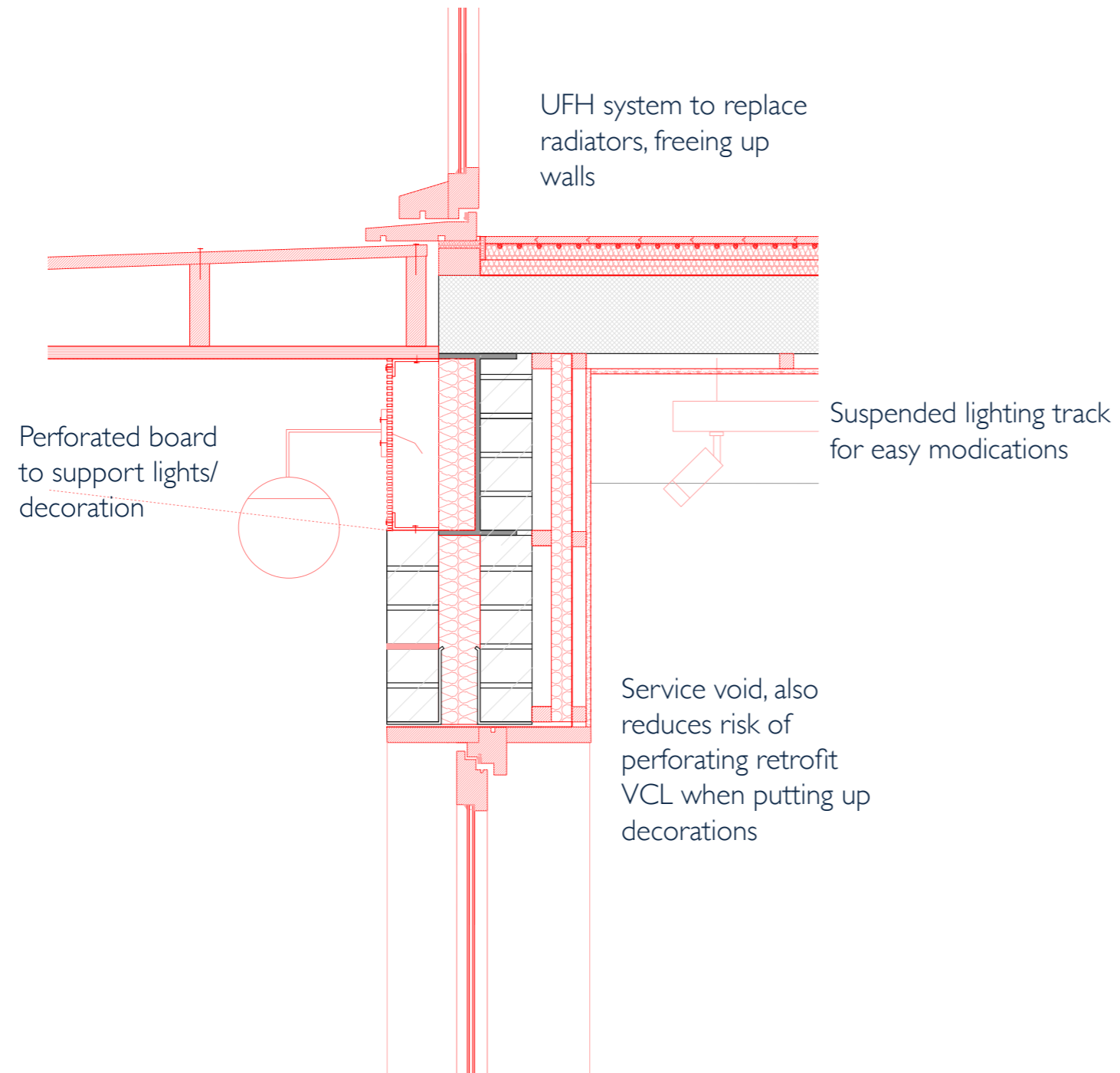



# A corridor to meet others?

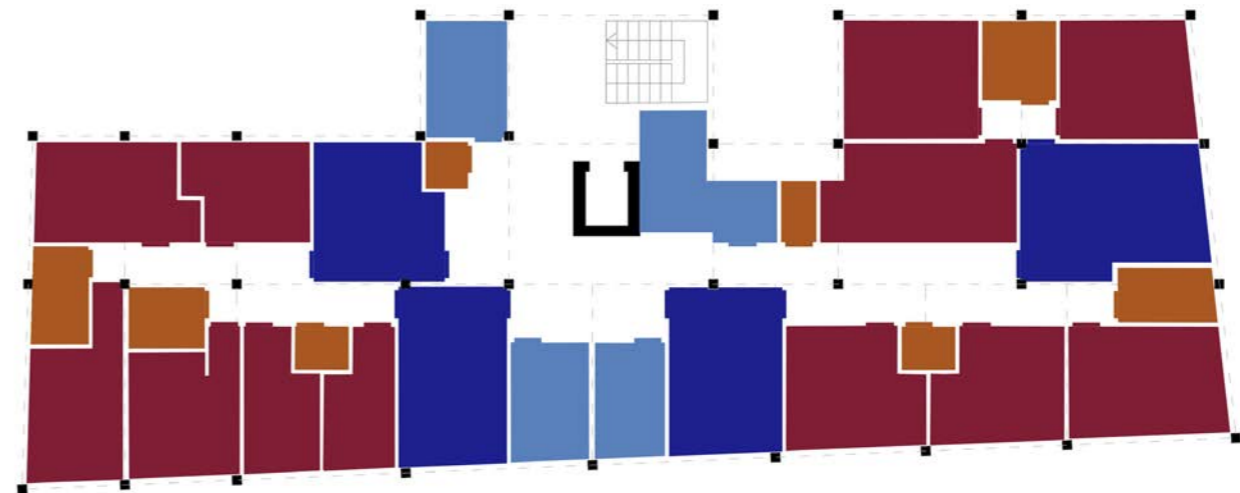



# A corridor to meet others

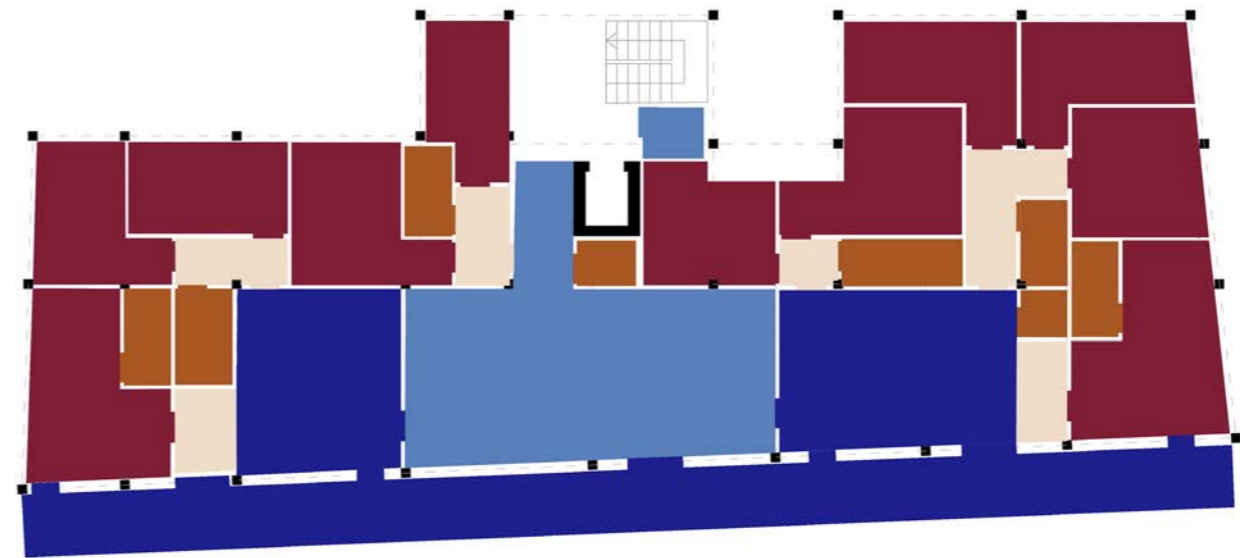
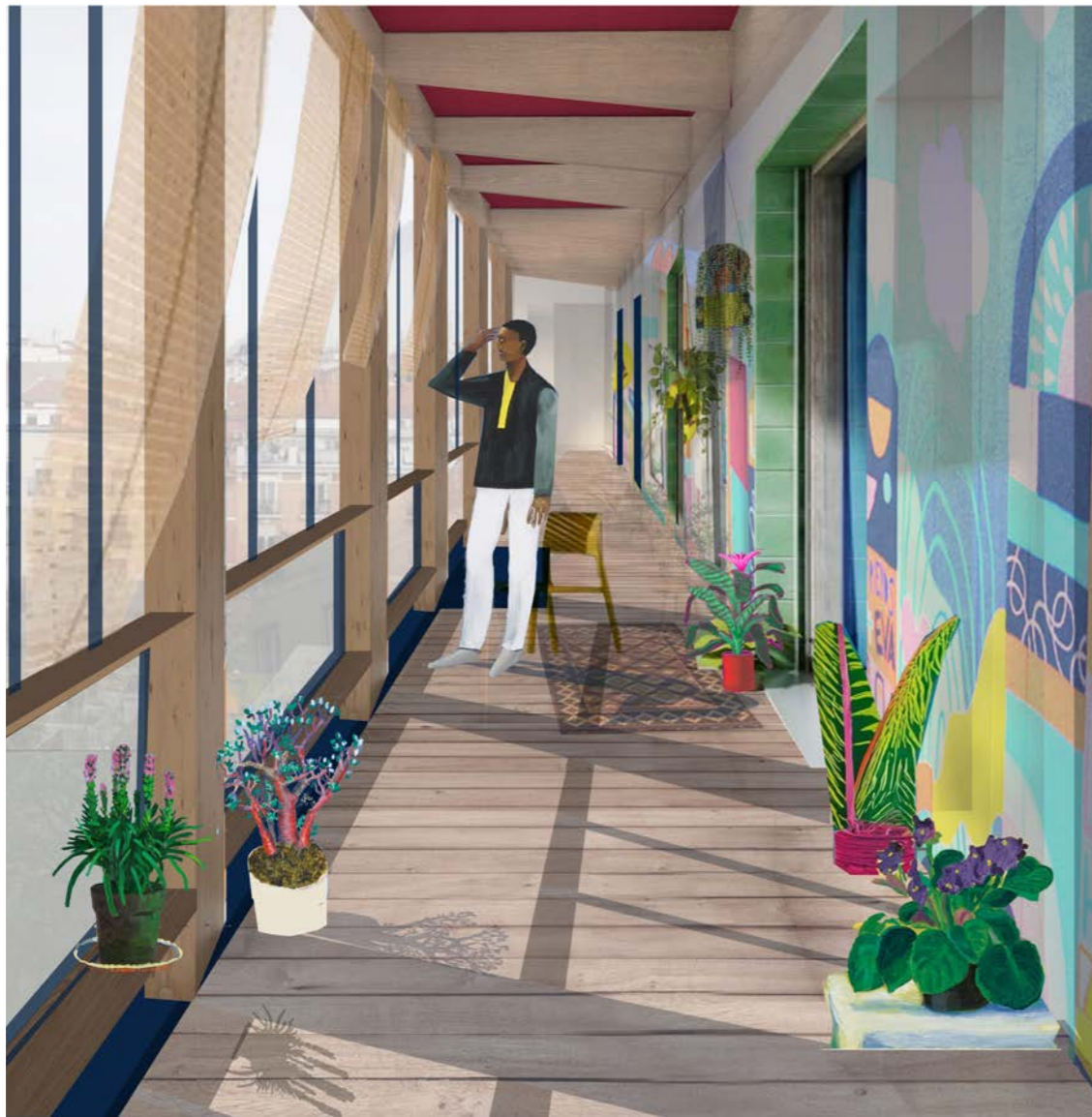



# Blurring spatial thresholds





# Blurring spatial thresholds

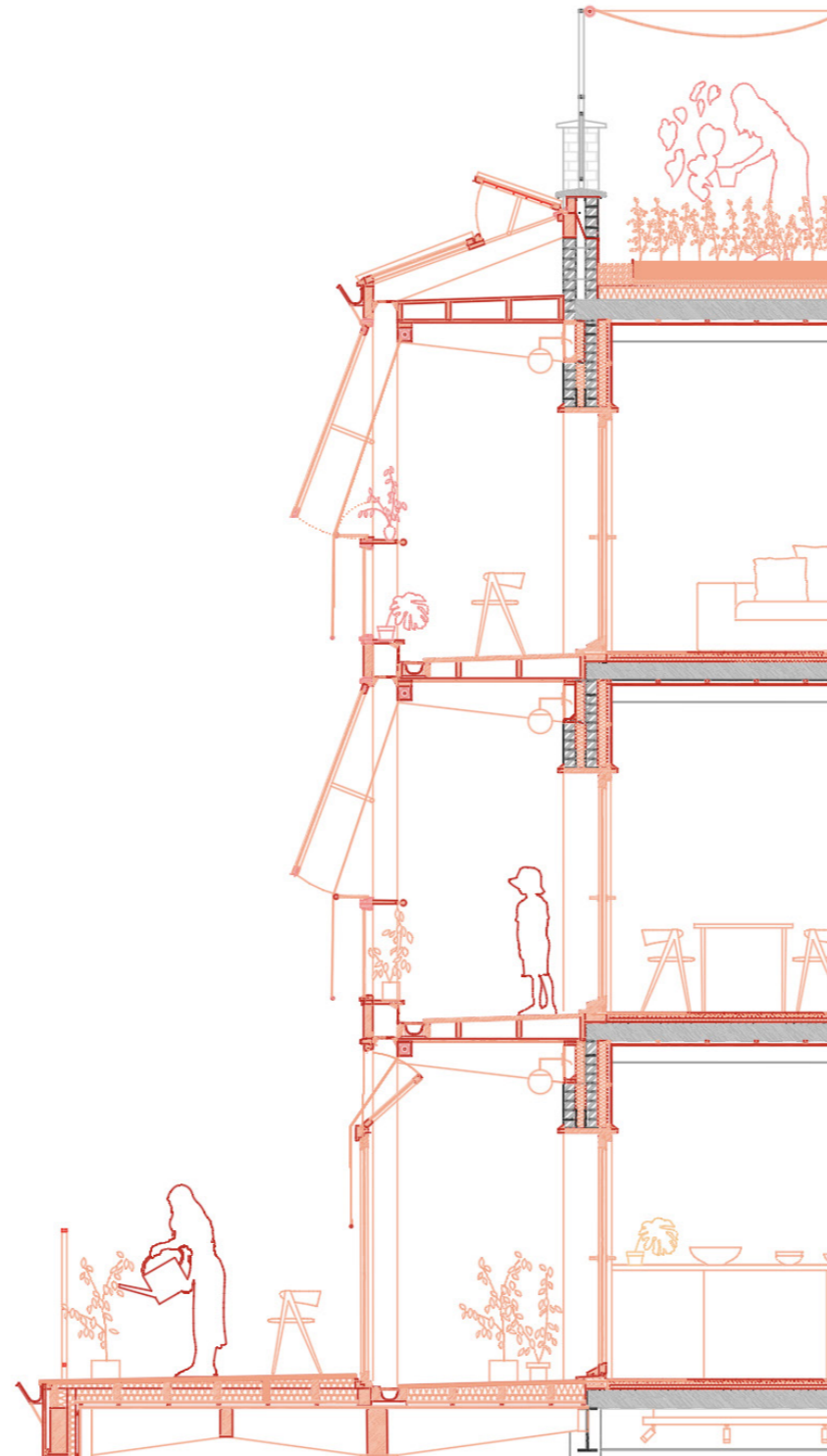



# A space for individual personality





# Blurring spatial thresholds





# Climatic Adaptations

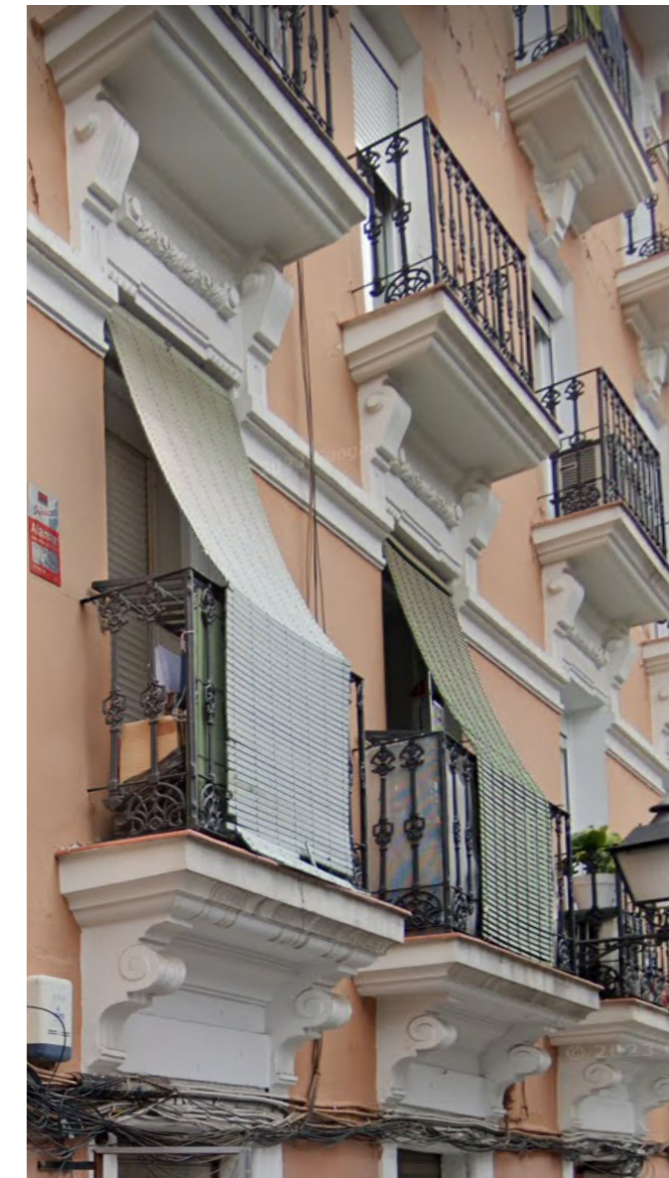
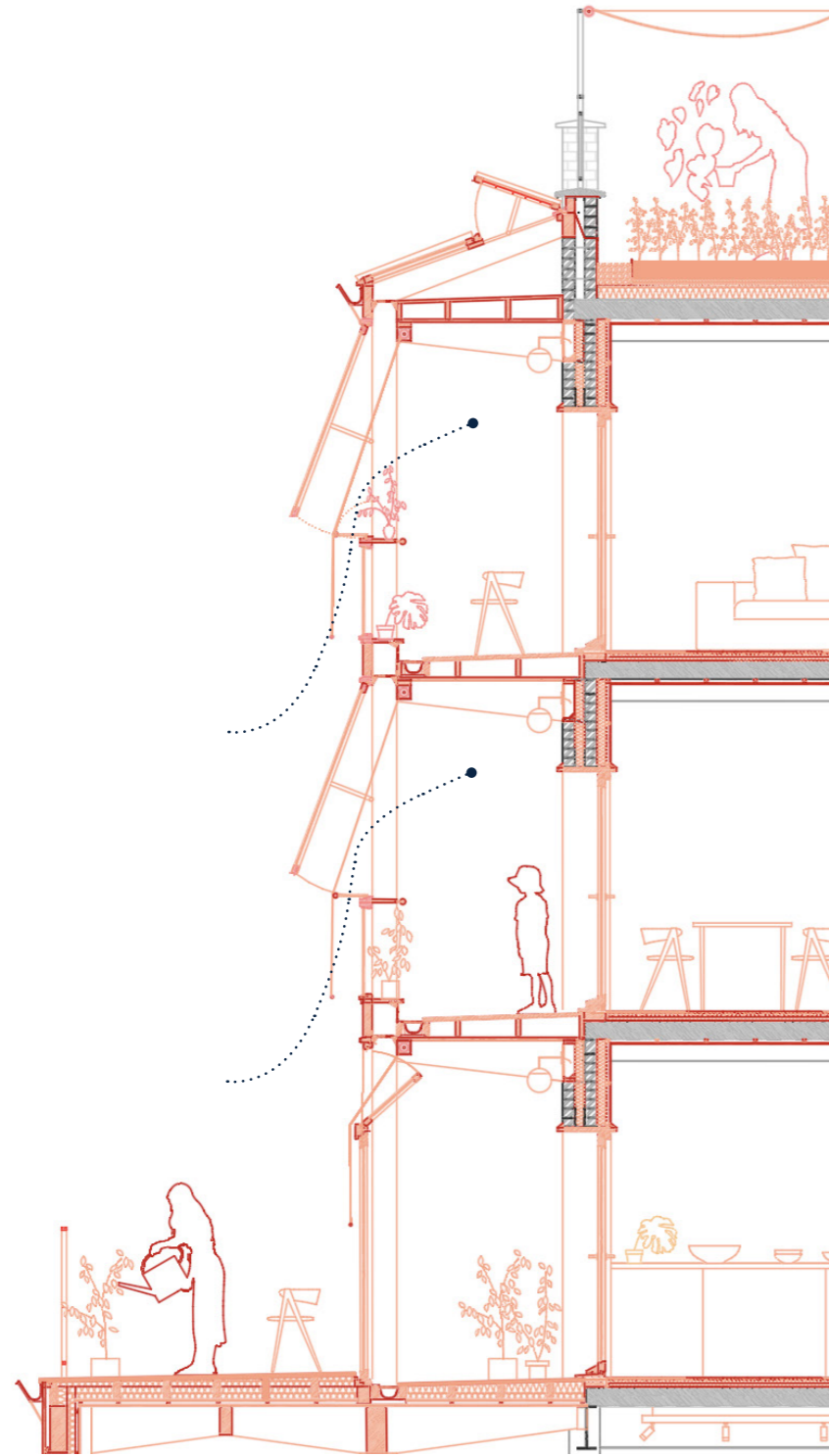



# Climatic Adaptations

Summer

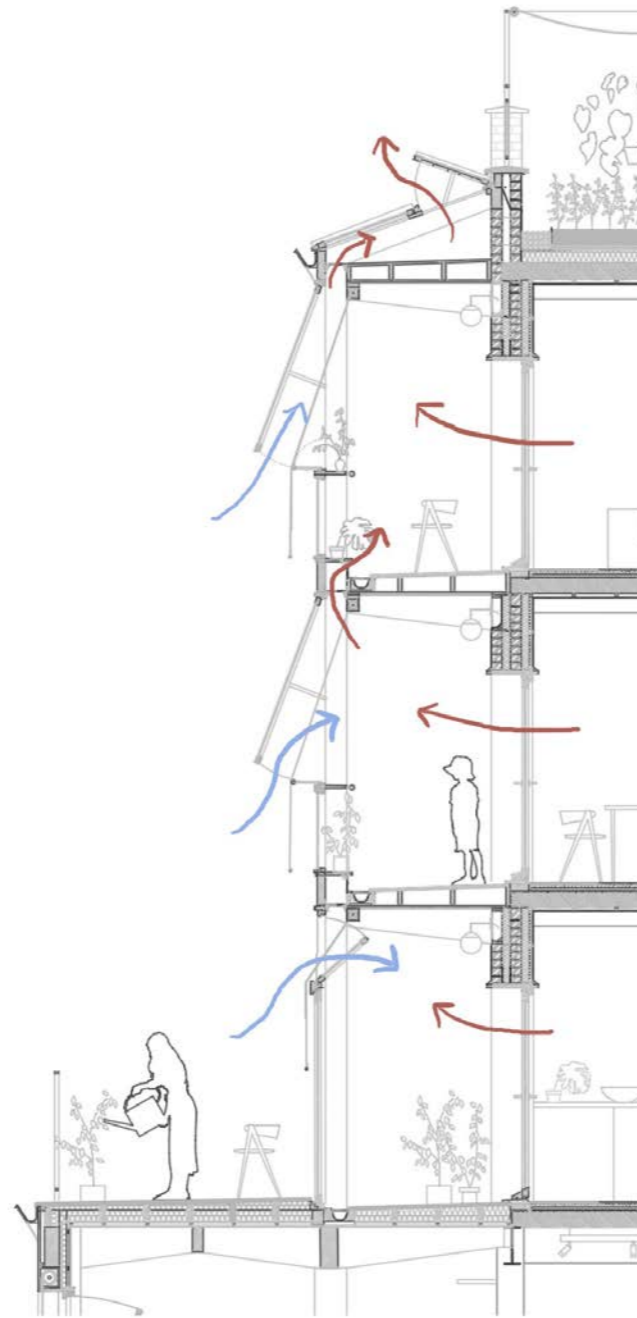

Winter

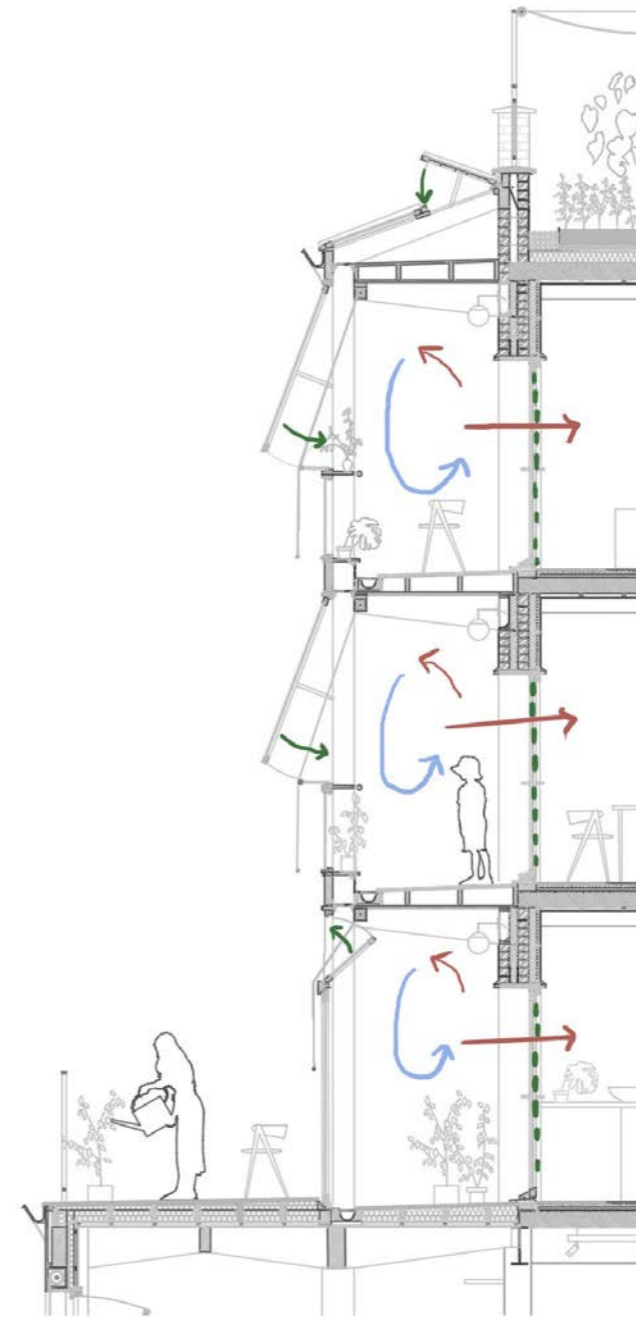



# Personal Adaptations

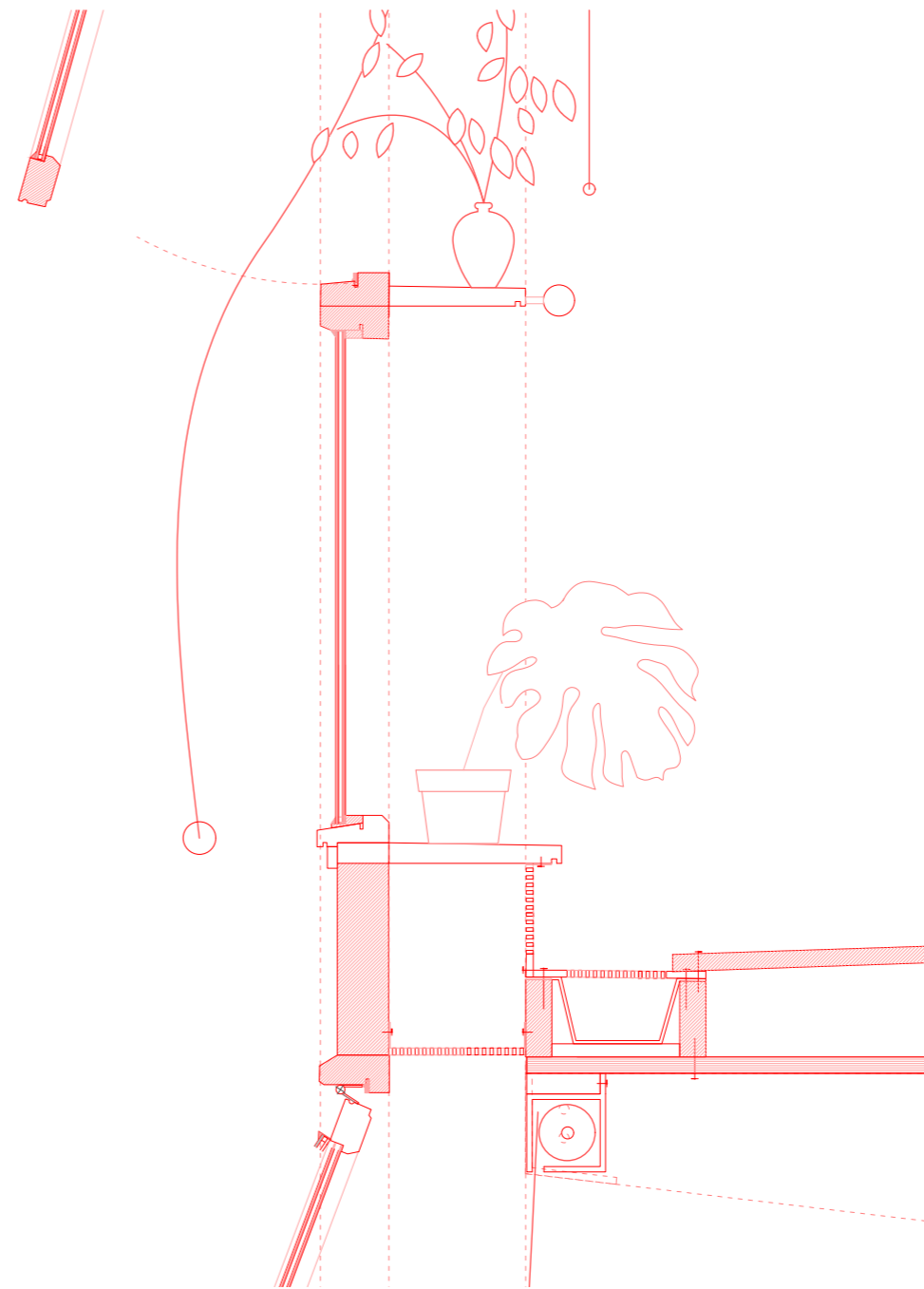
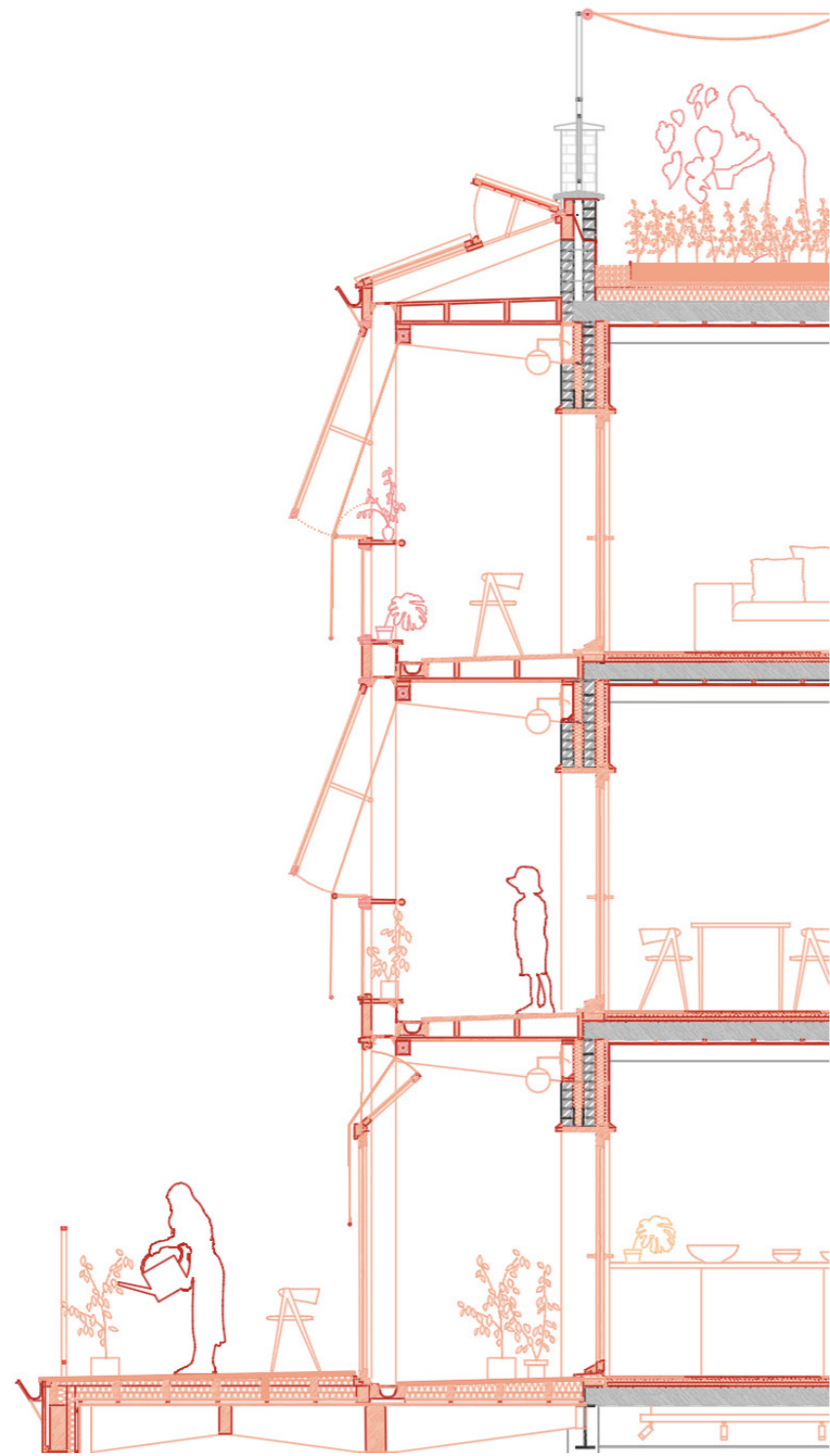



# A Winter Garden

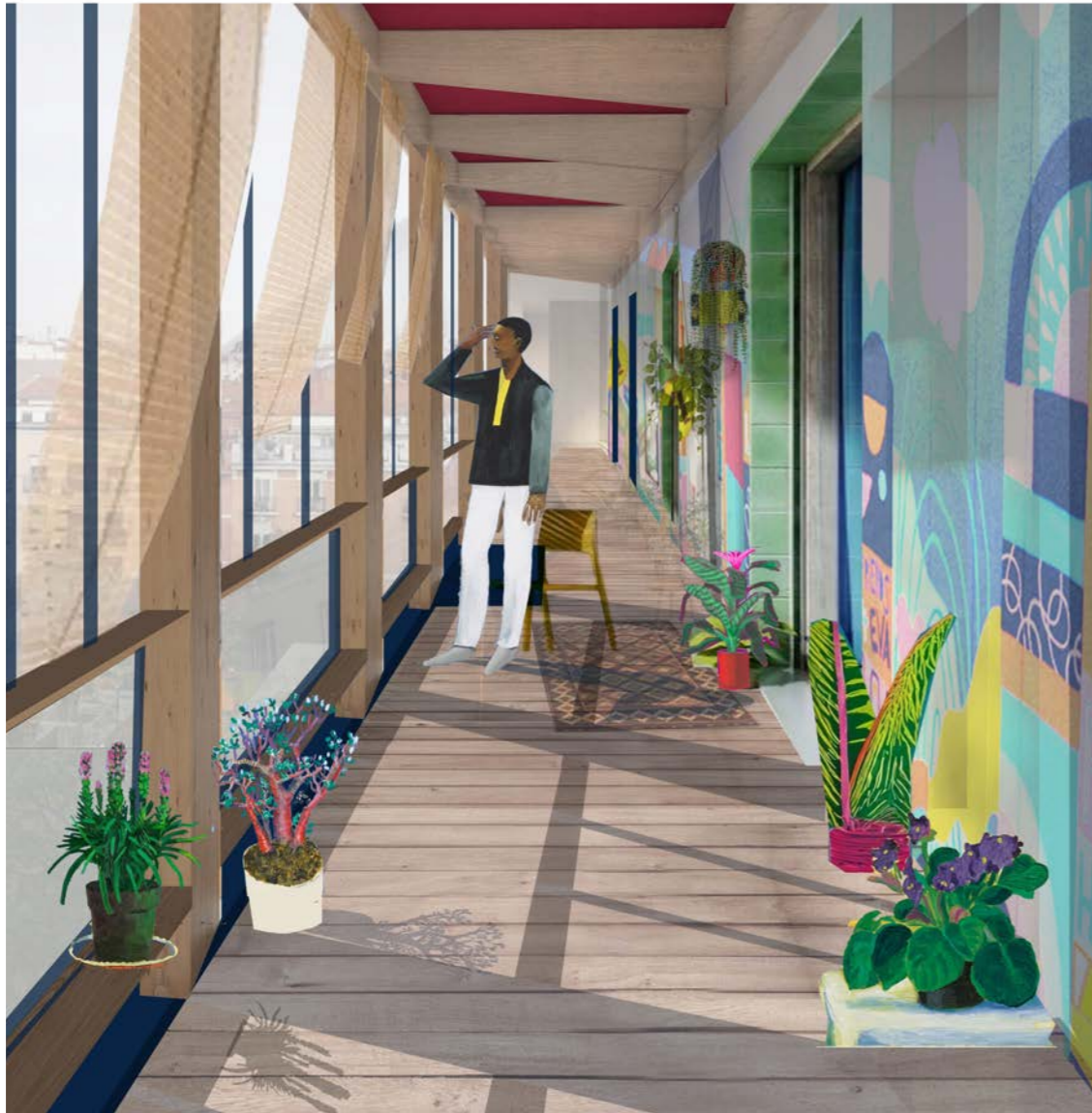



# A vertical community garden

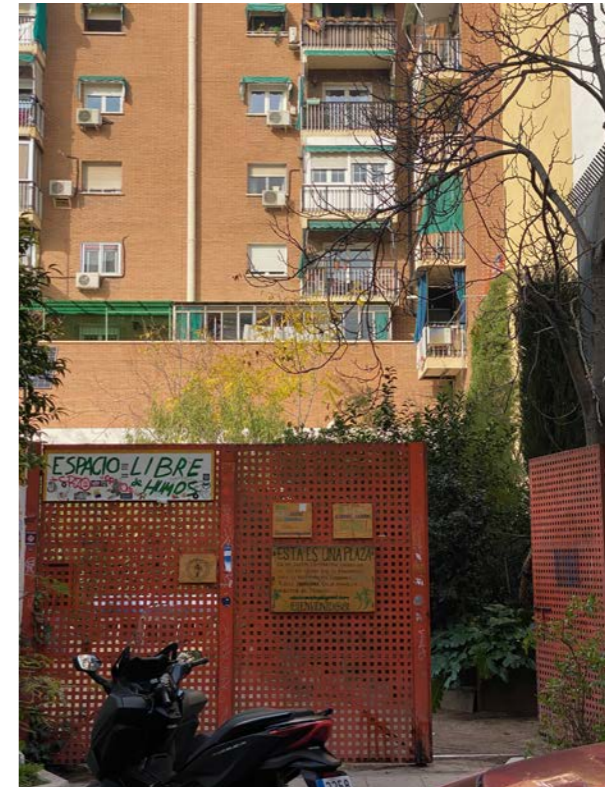
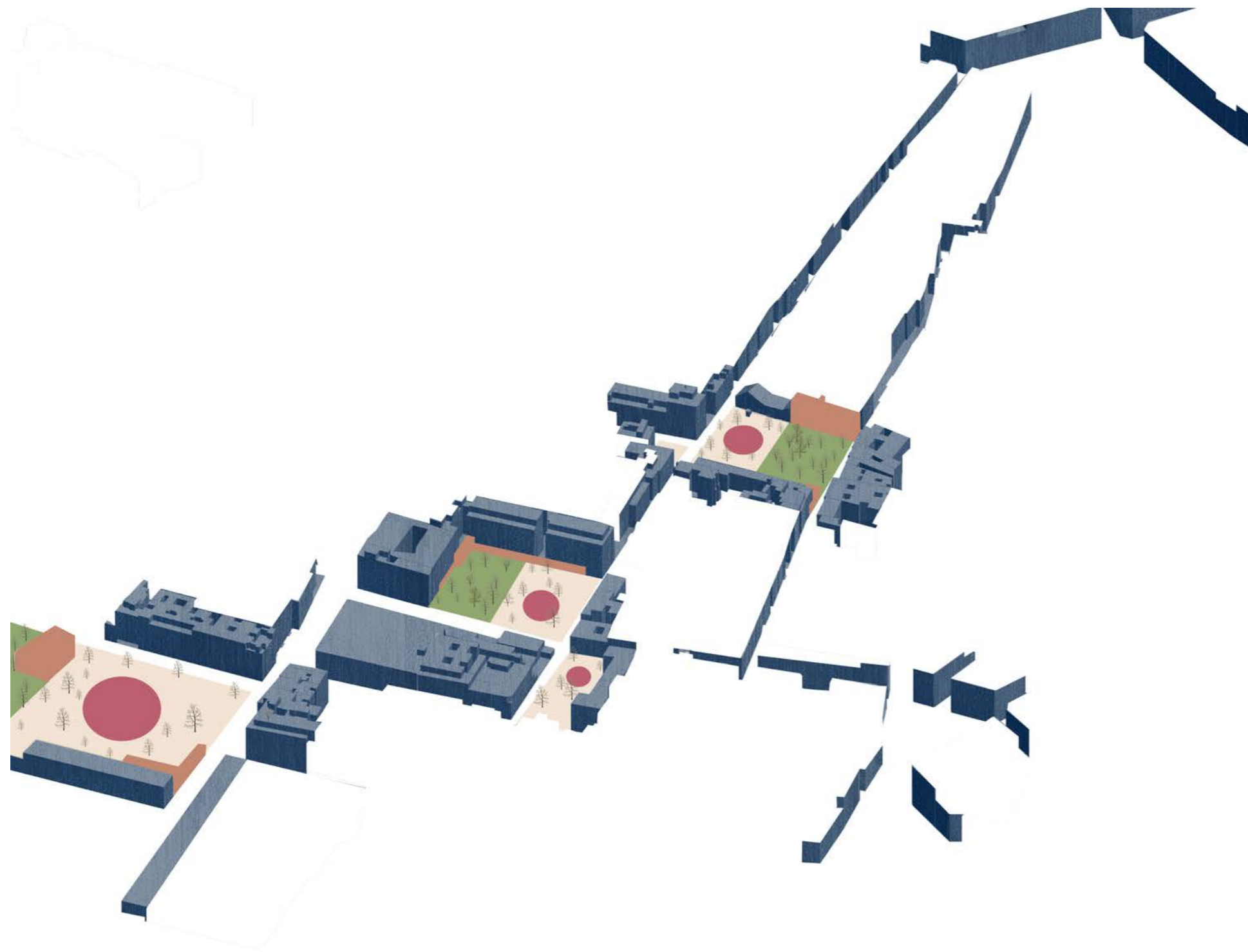



# A vertical community garden

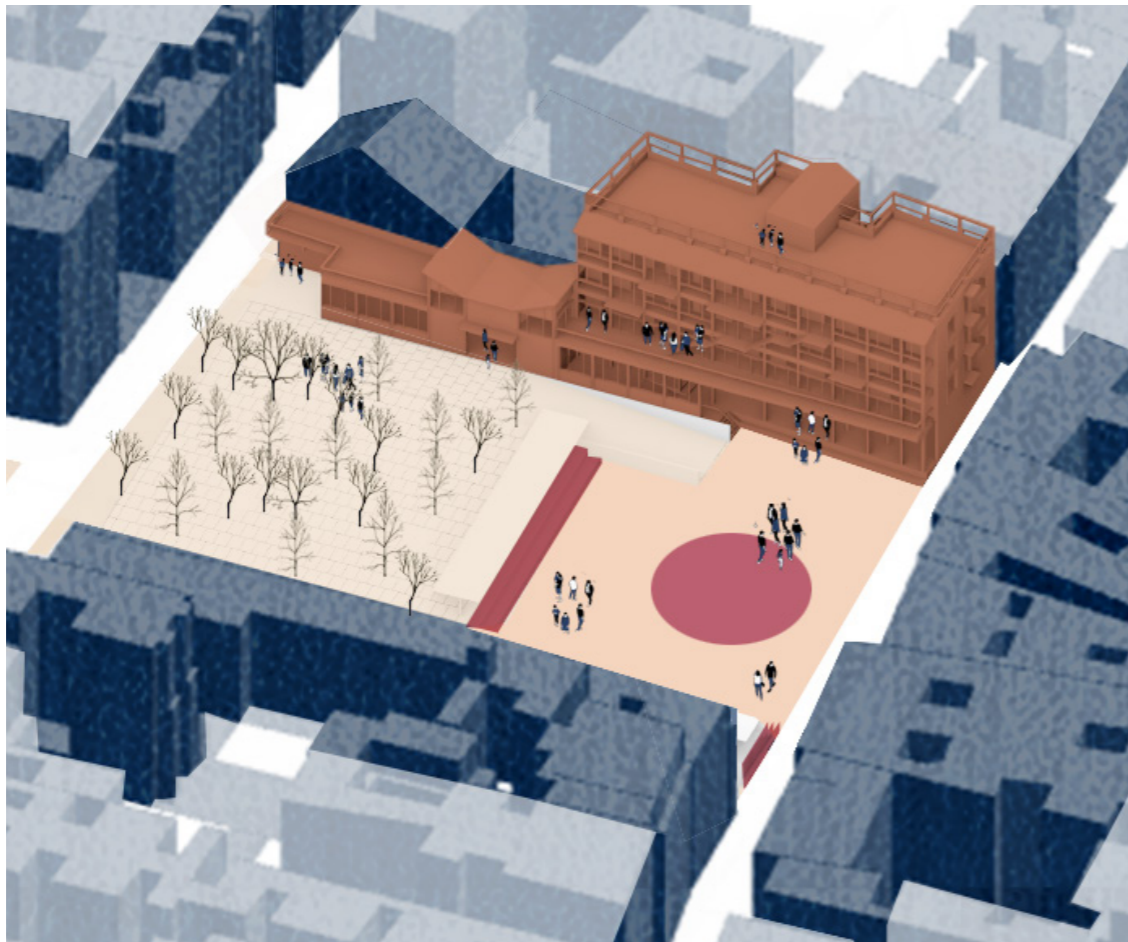



# Seasonal Ventilation Principles

- Natural cross ventilation
- Constant MVHR system for basement, kitchen and toilets
- Waste humidity used in cold frames of roof garden

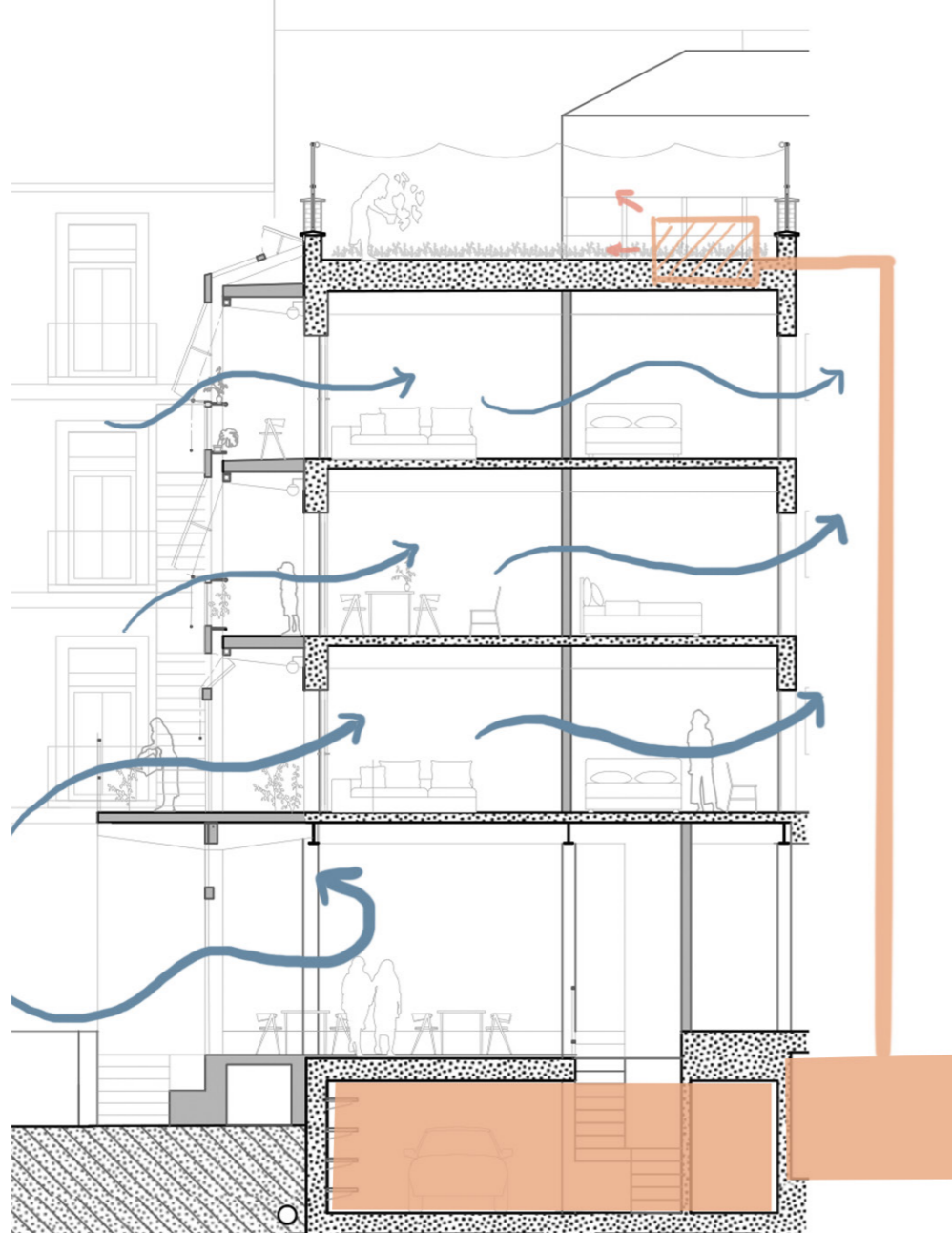

Spring/Autumn

- Separate mechanical ventilation system for temporary use (seasonal flats, or during high occupancy on the ground floor) (in ducts in suspended ceiling)
- Constant MVHR system for basement, kitchen and toilets

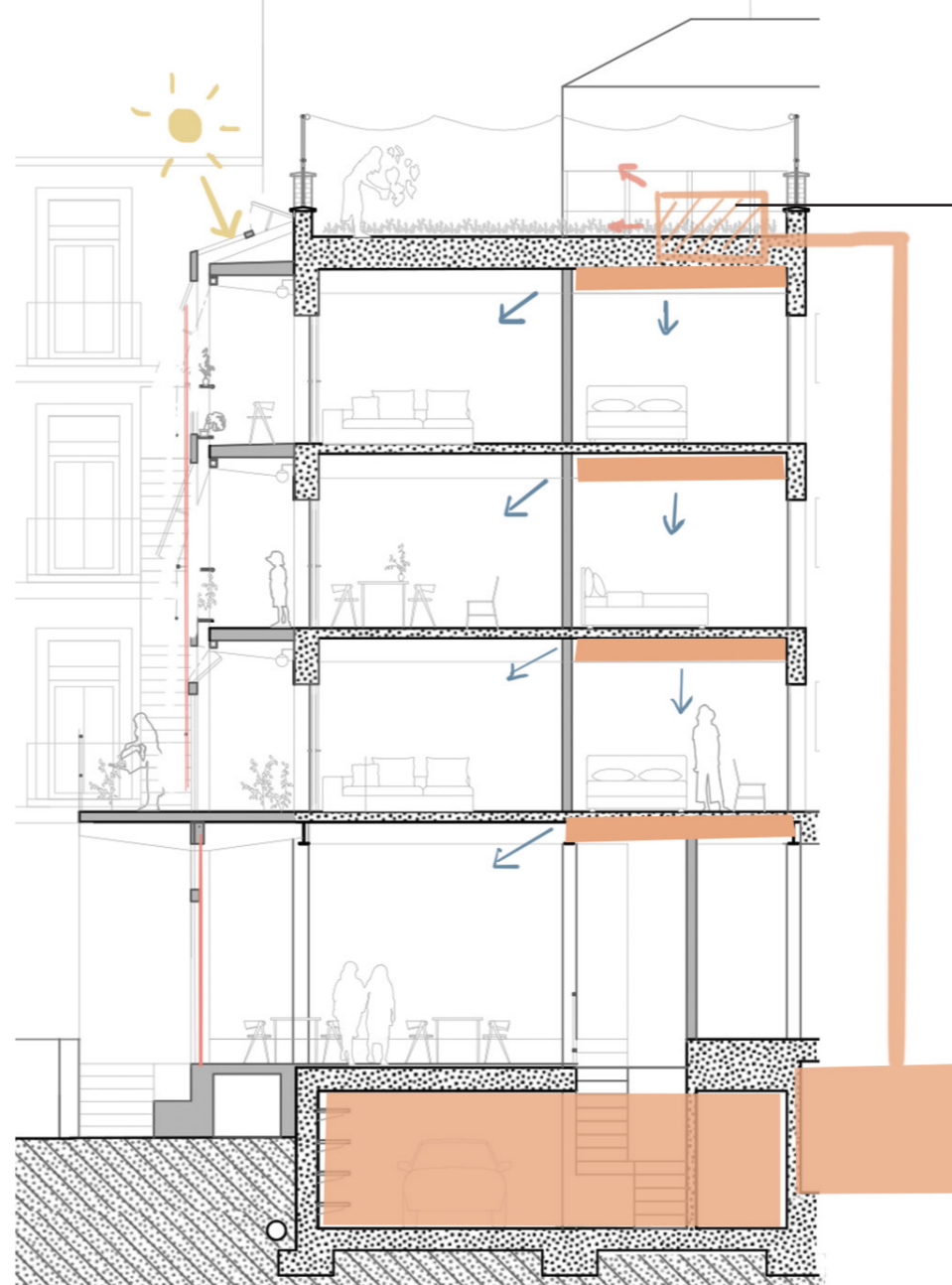

Summer/Winter/High Occupancy





# An under-used asset

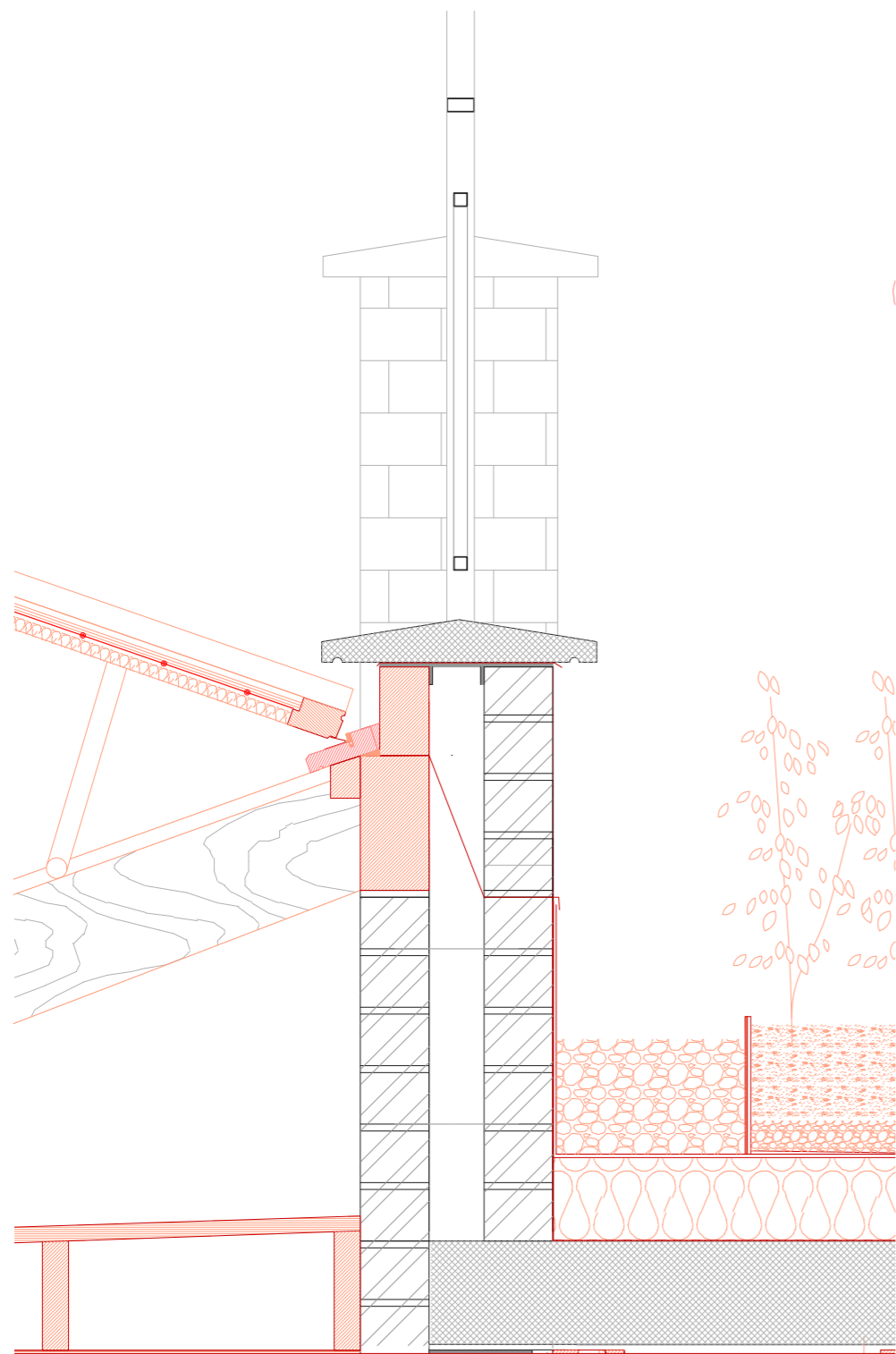



# A roof to water the building

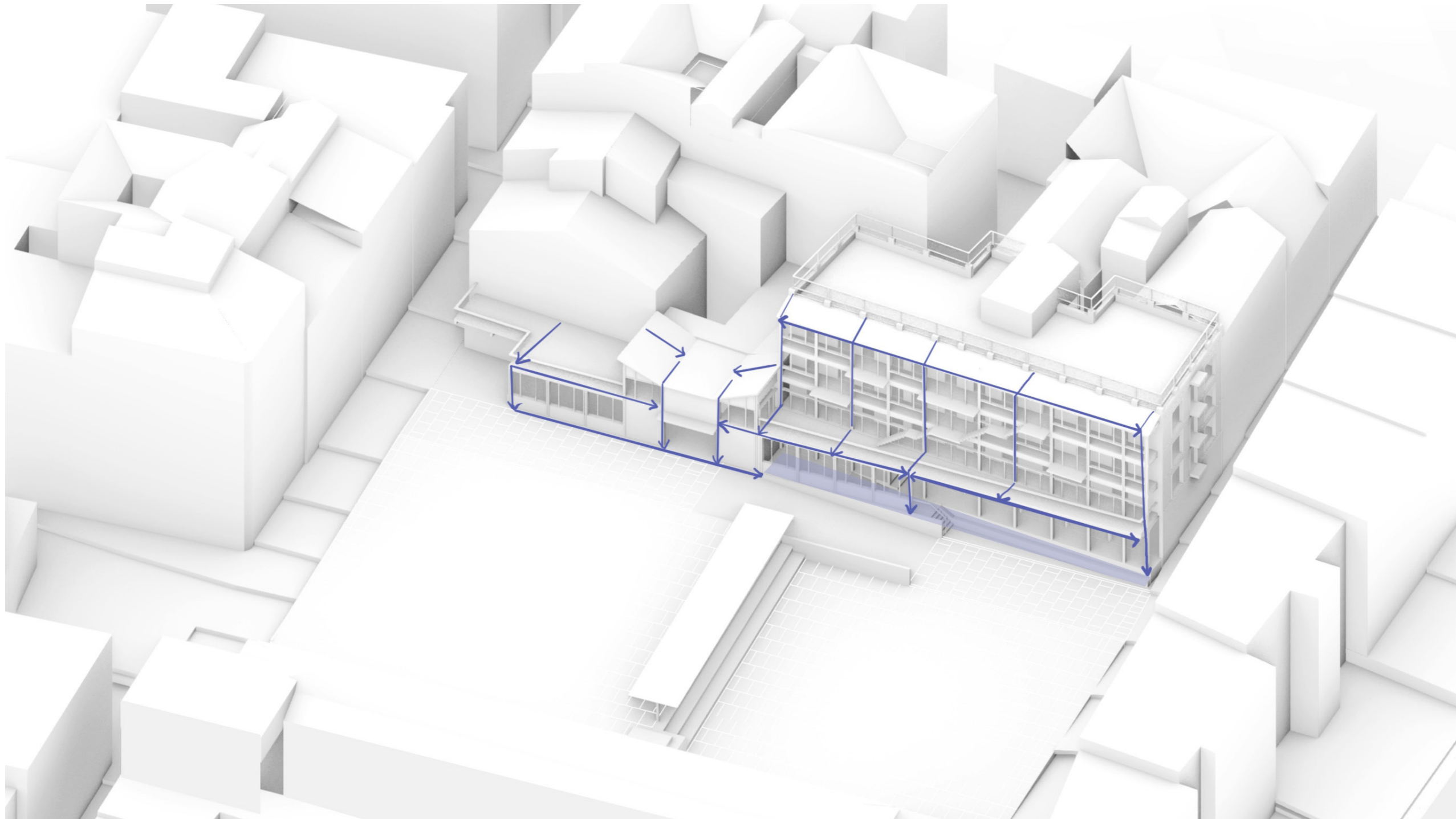



# For the neighbourhood

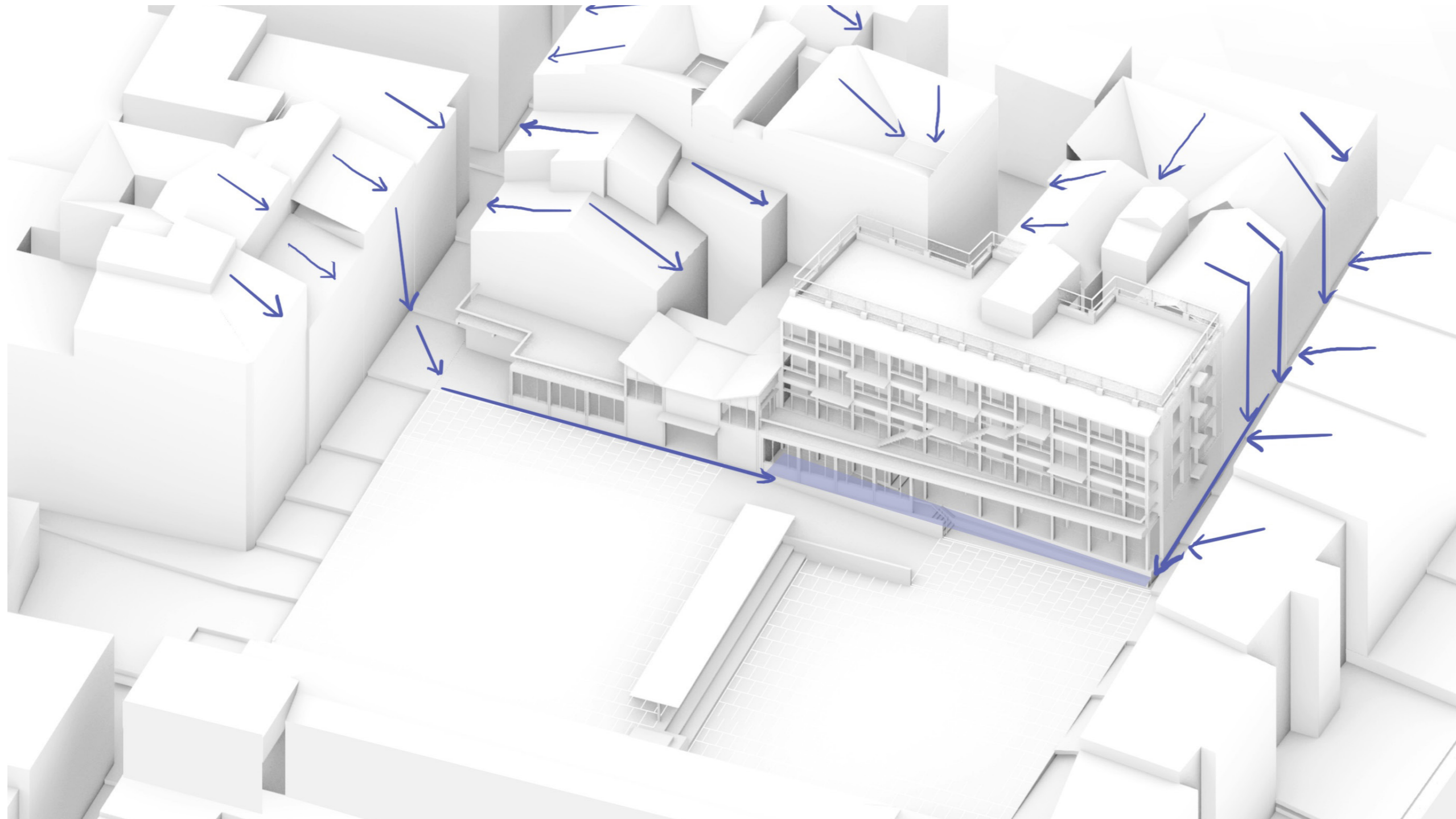



# Workshop





# Workshop

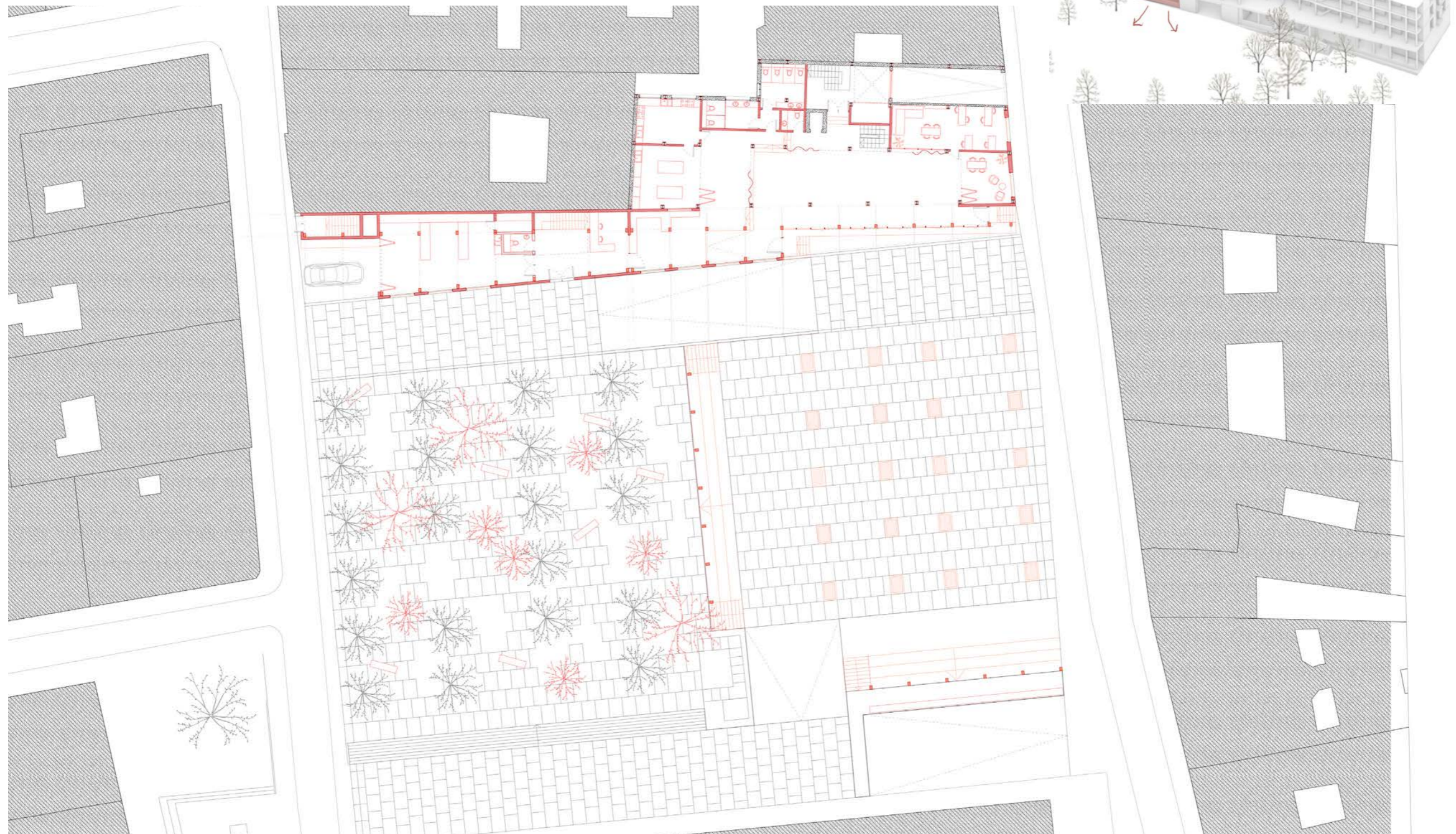



# The Plaza?

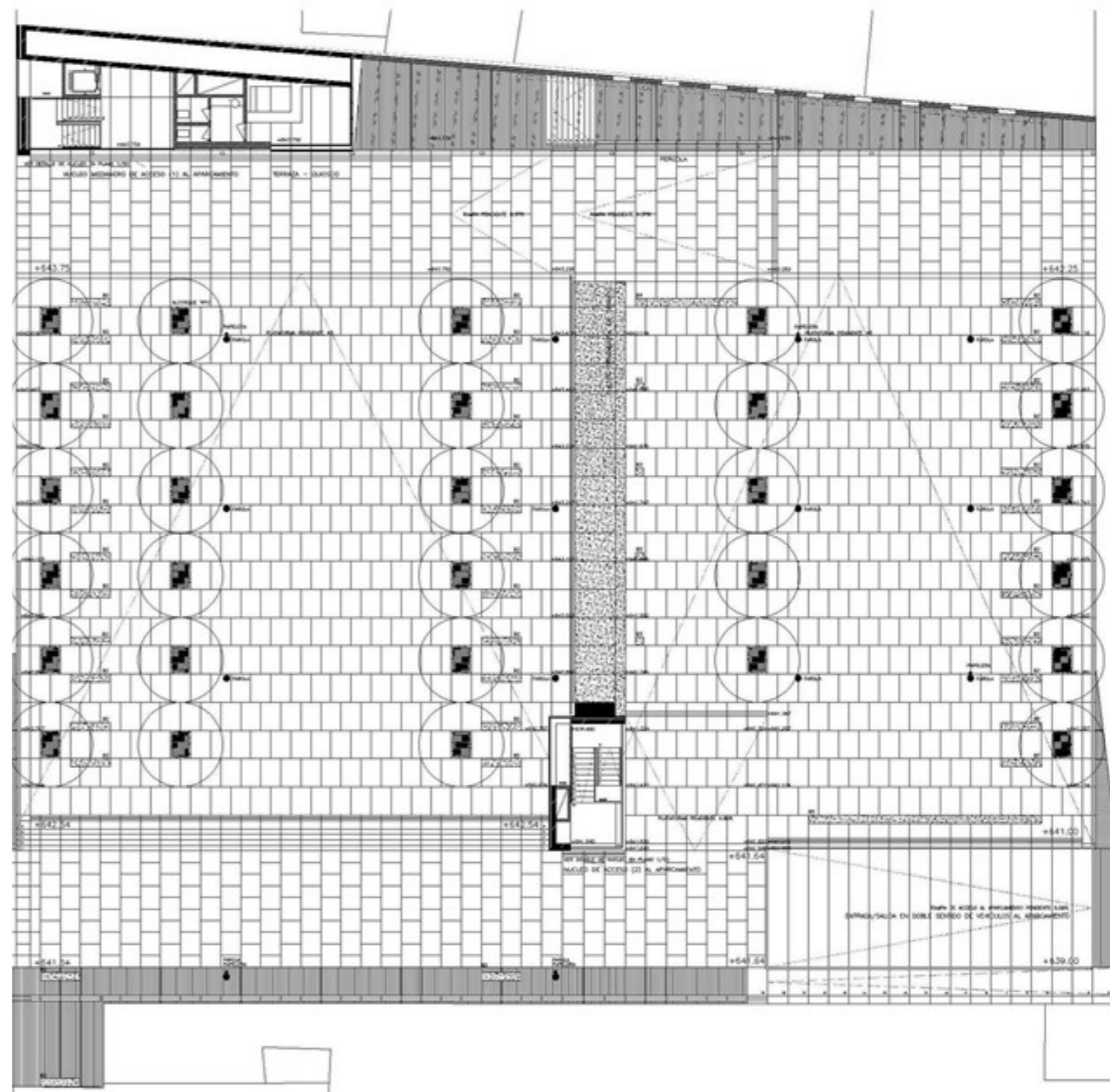



# The Plaza?

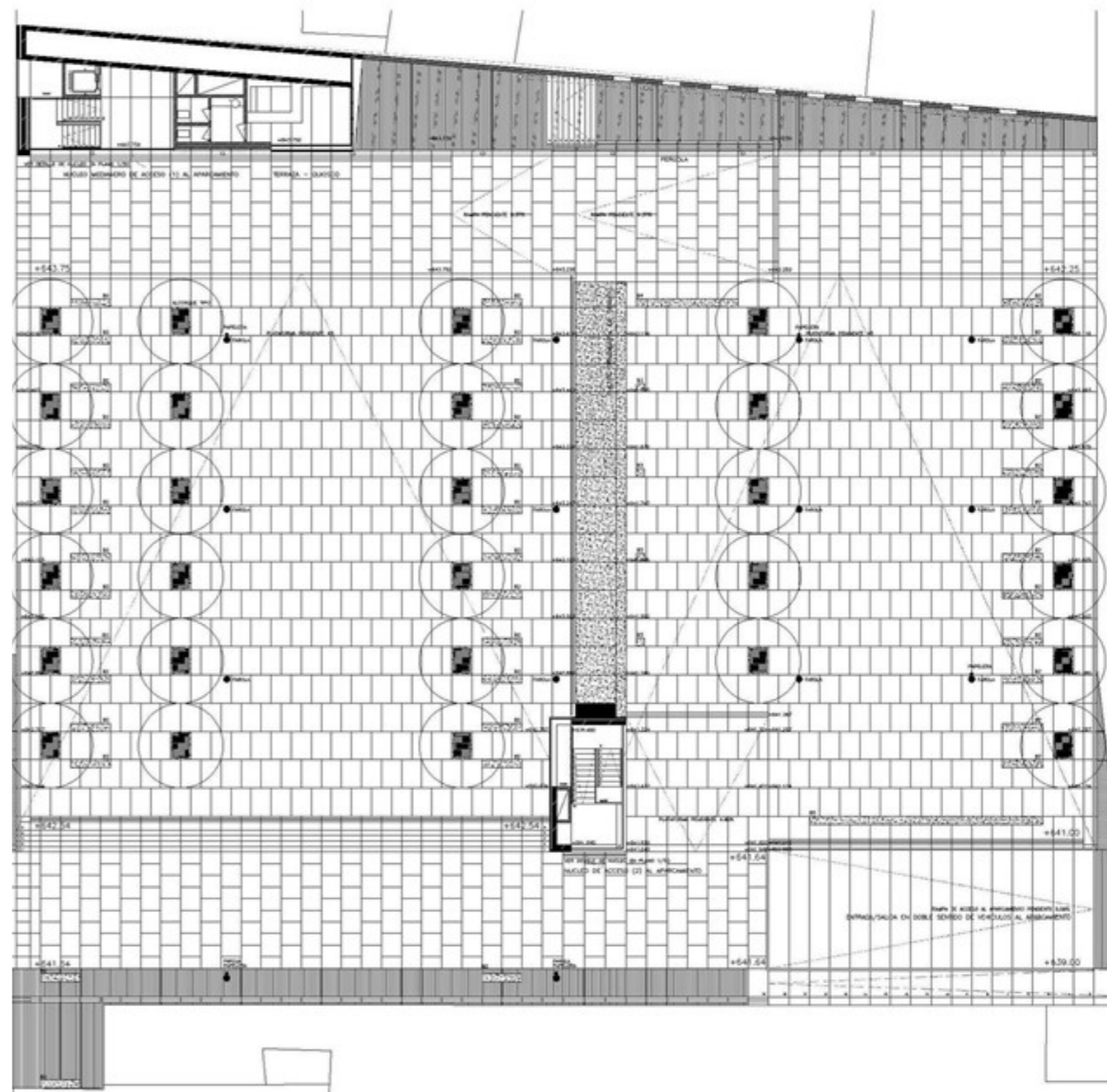



# Powering further expansions

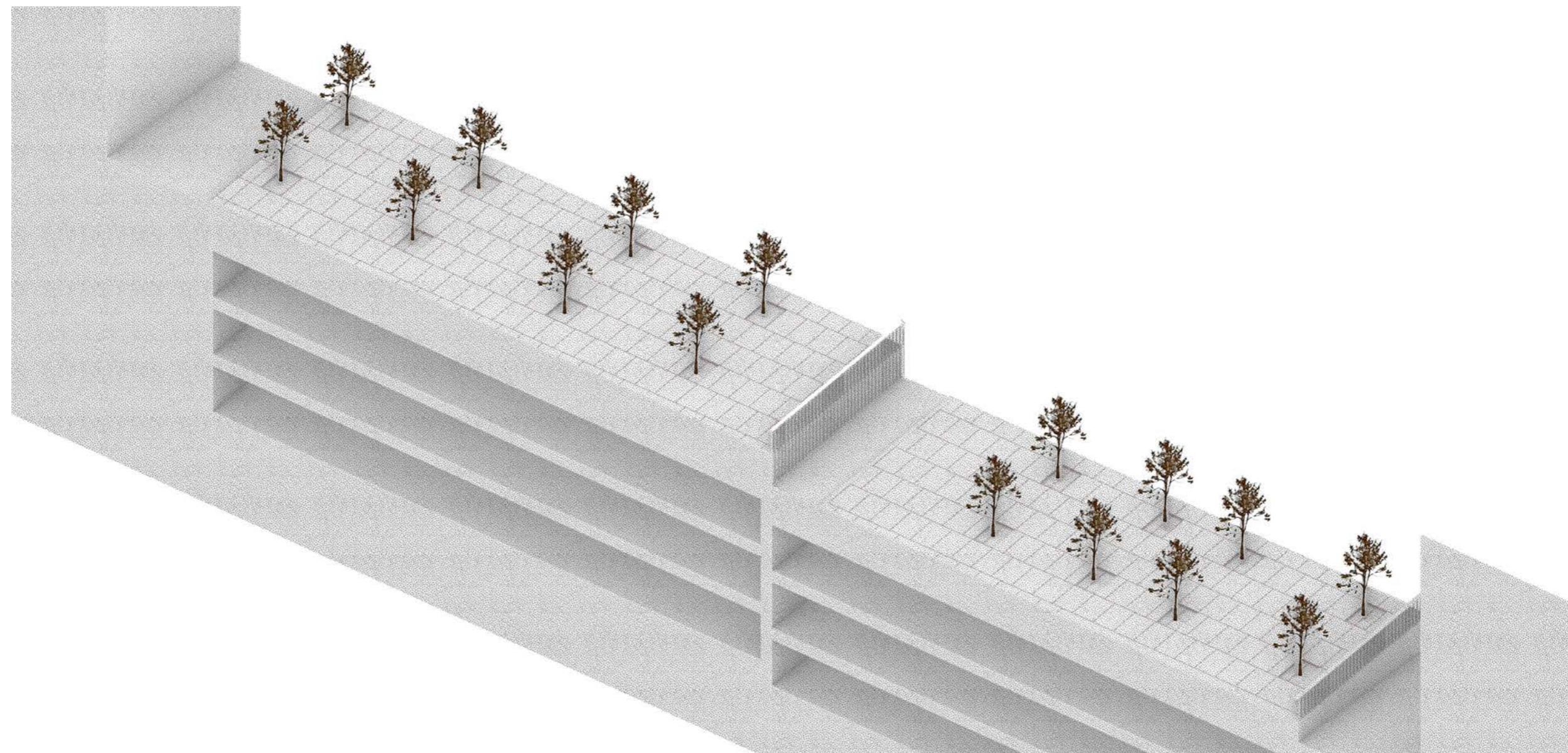



# Powering further expansions

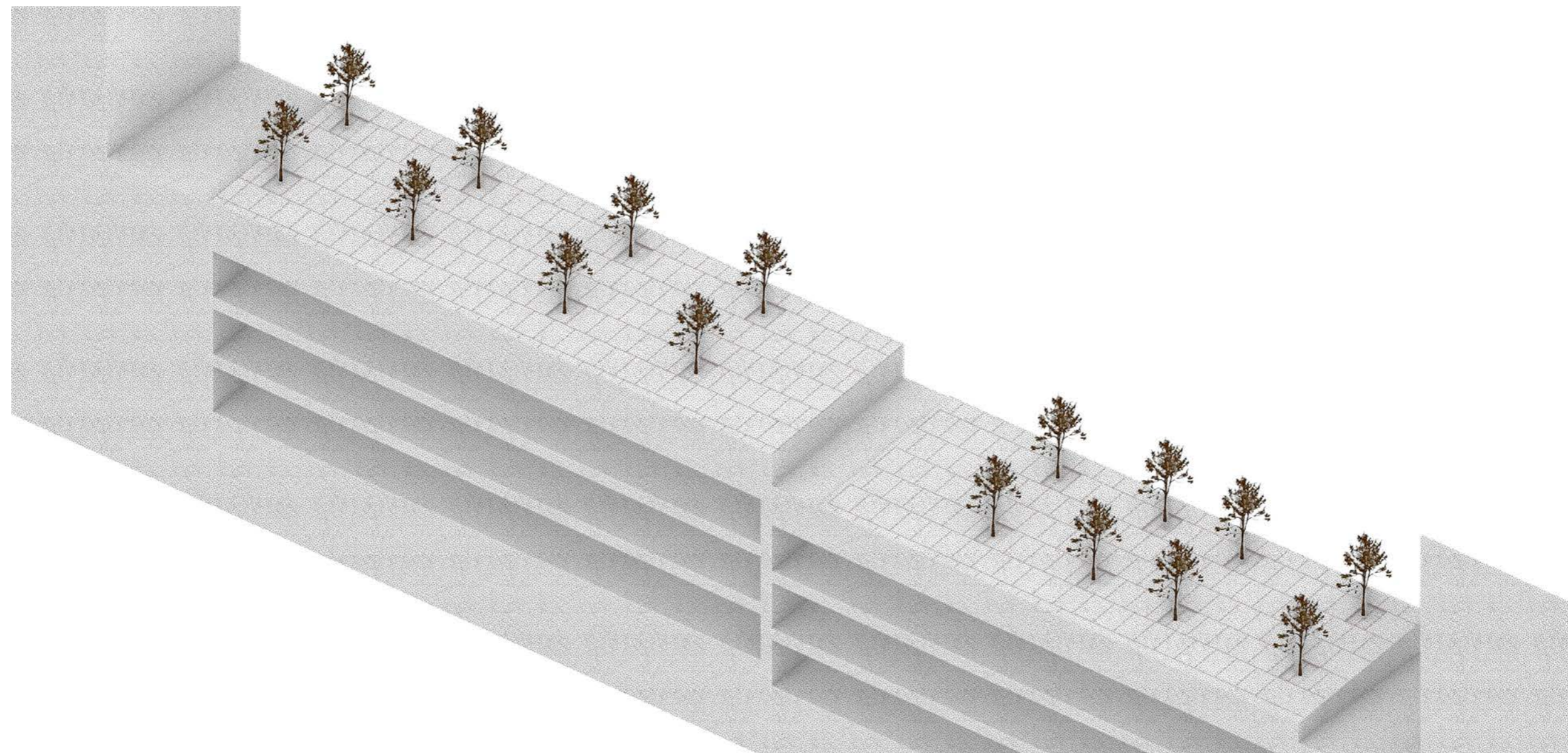



# Powering further expansions

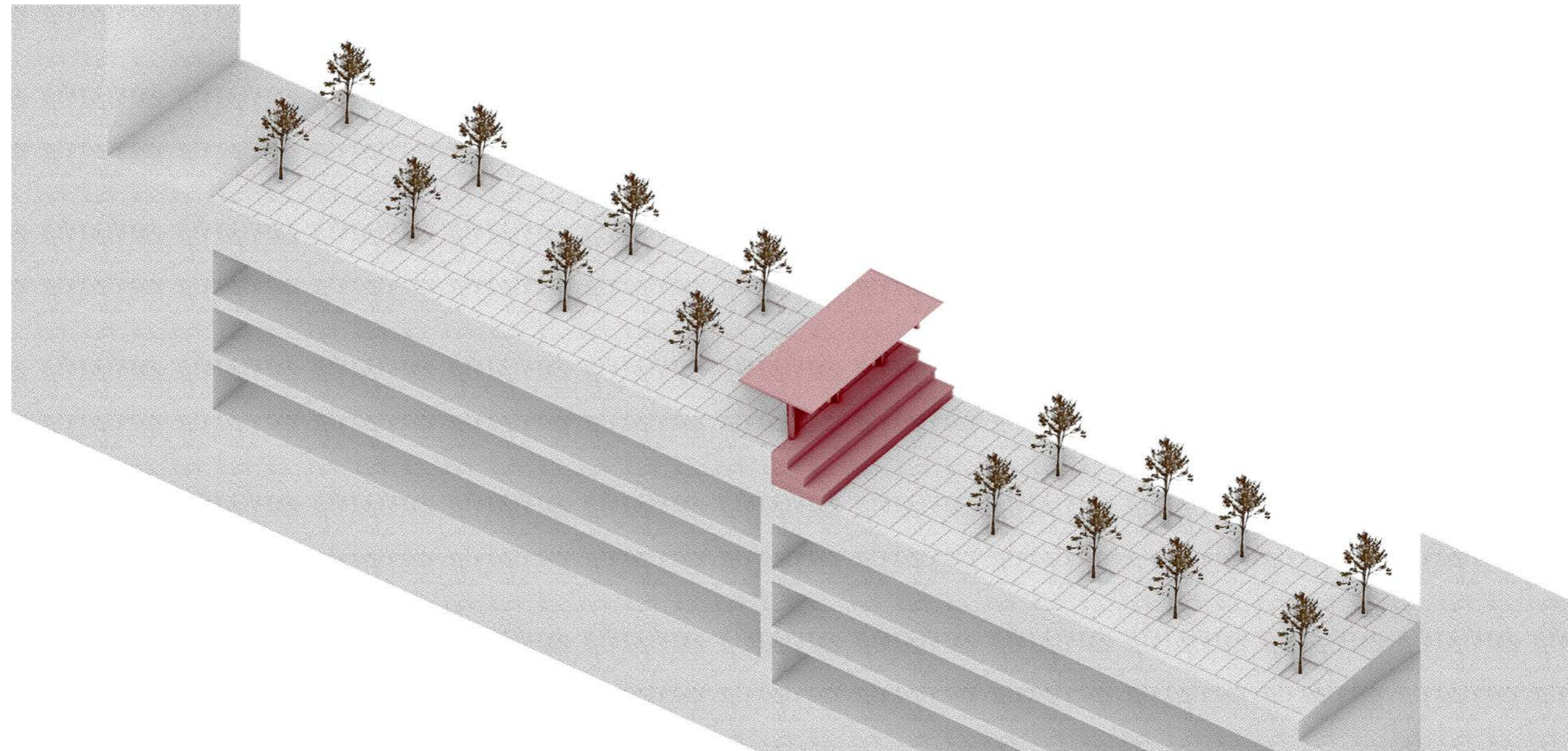



# Powering further expansions

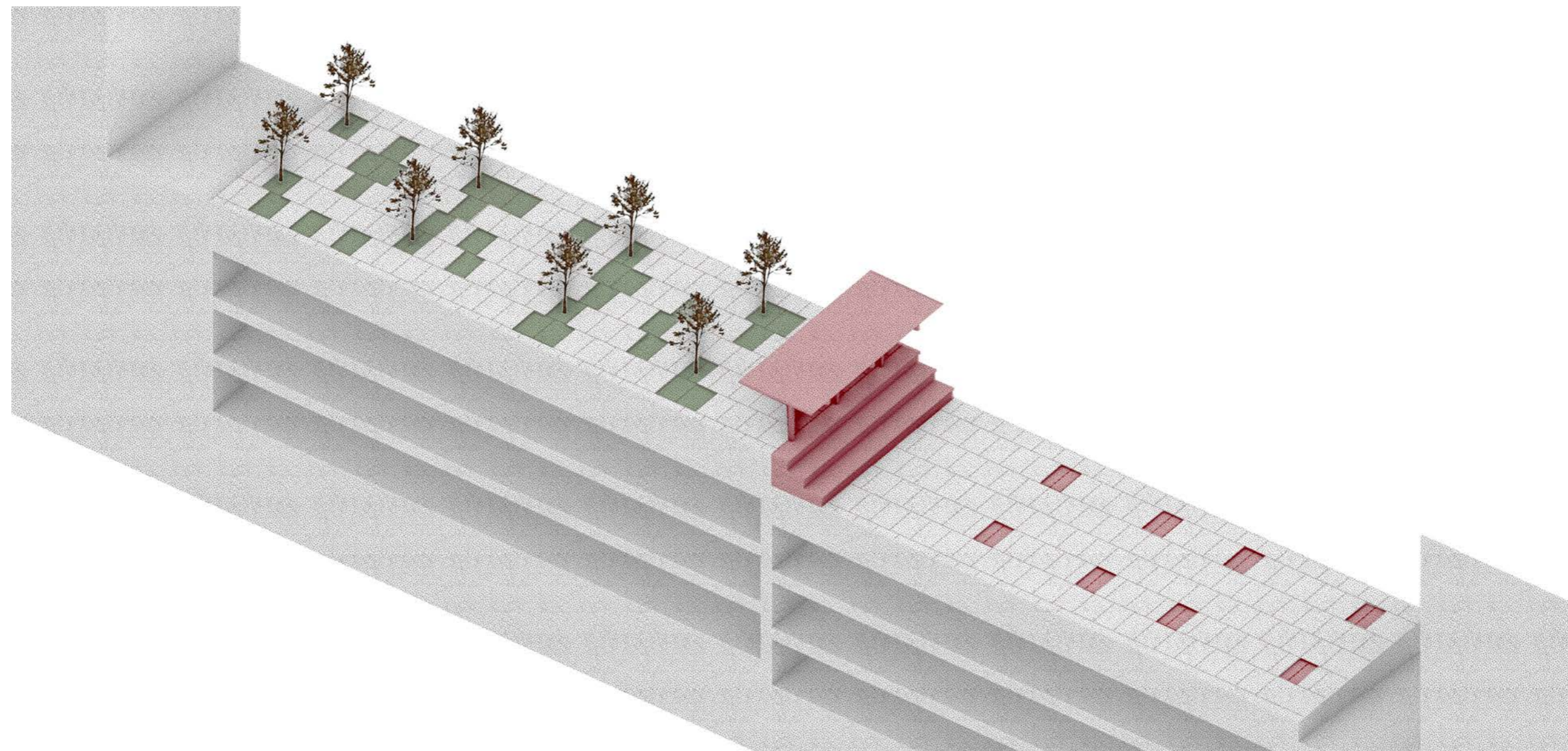



# Powering further expansions

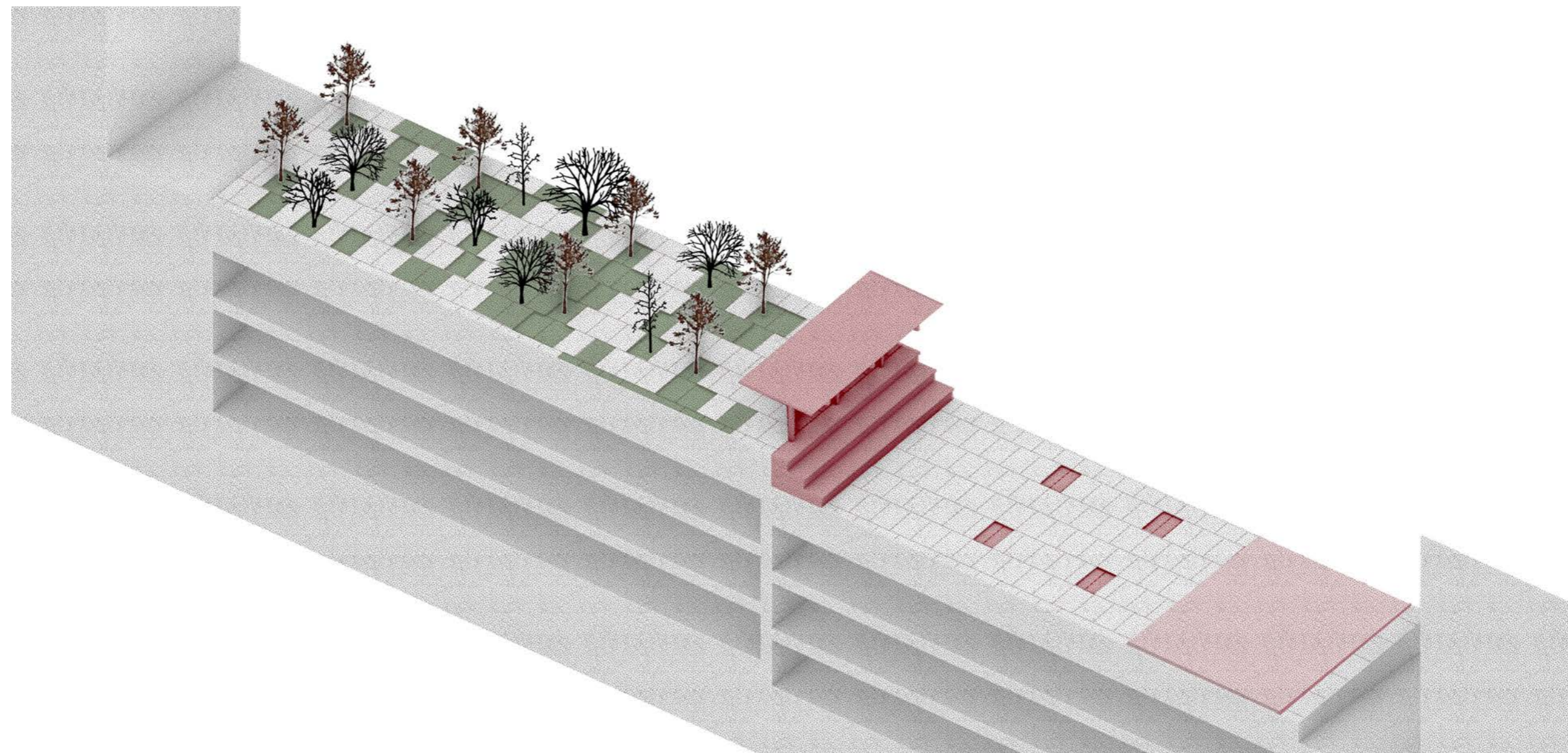



# Grounds for Theatricality





# Continued User Developments

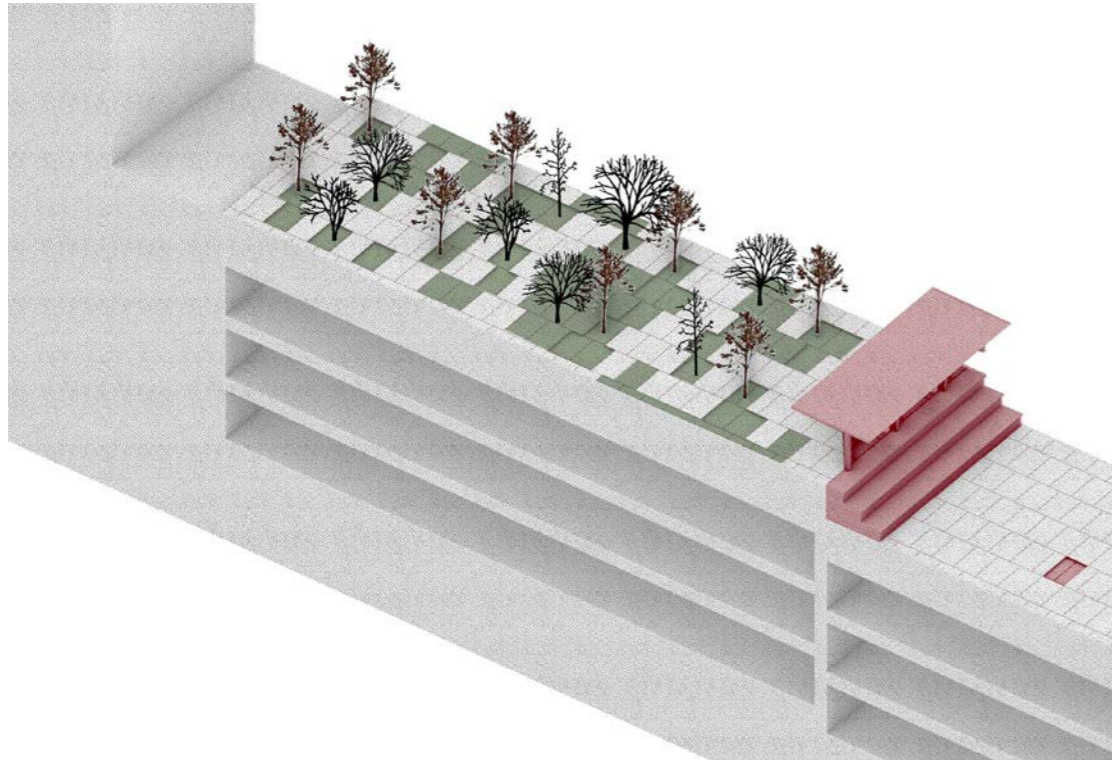



# Powering Appropriation





# Phasing

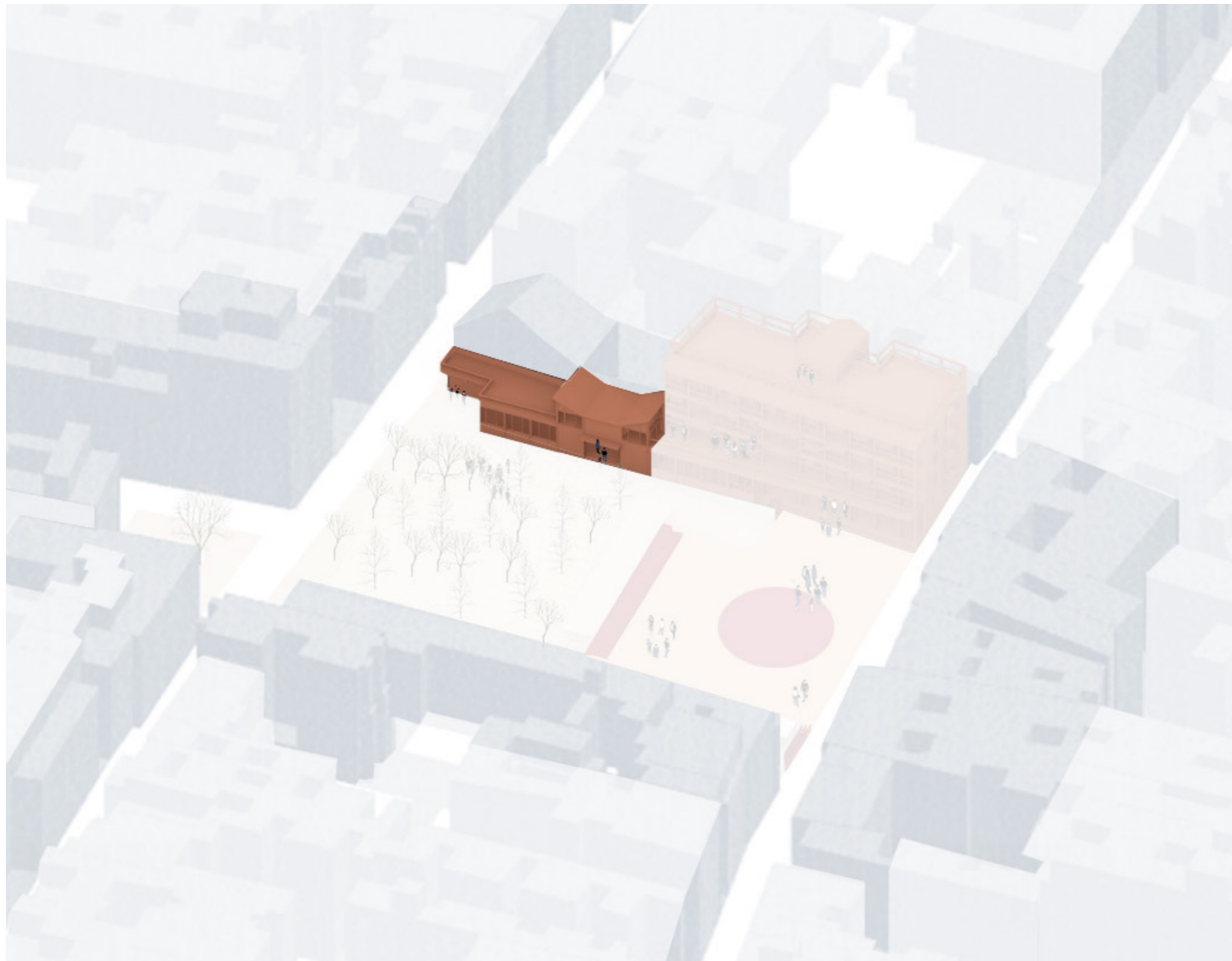



# Phasing

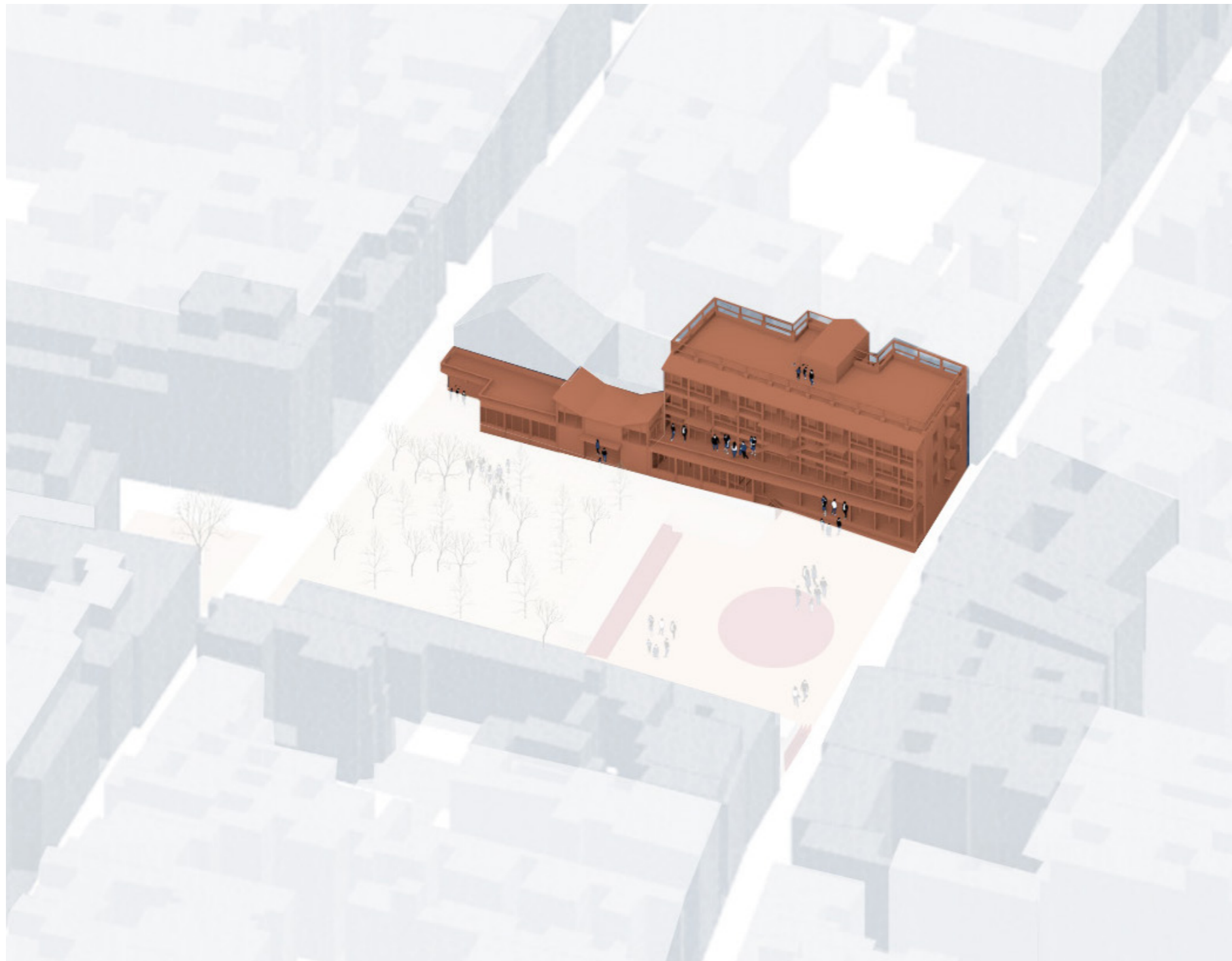



# Phasing

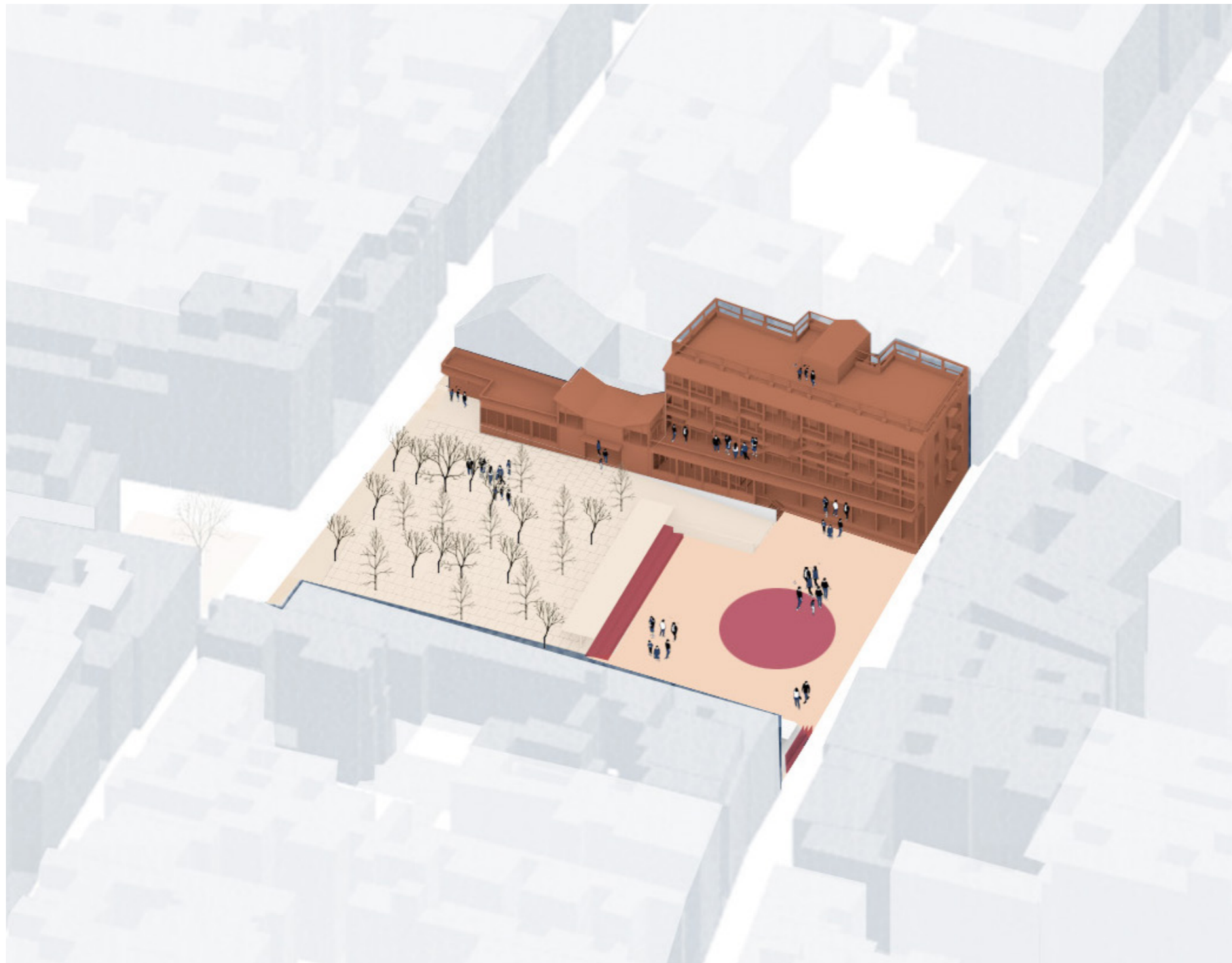



# Phasing

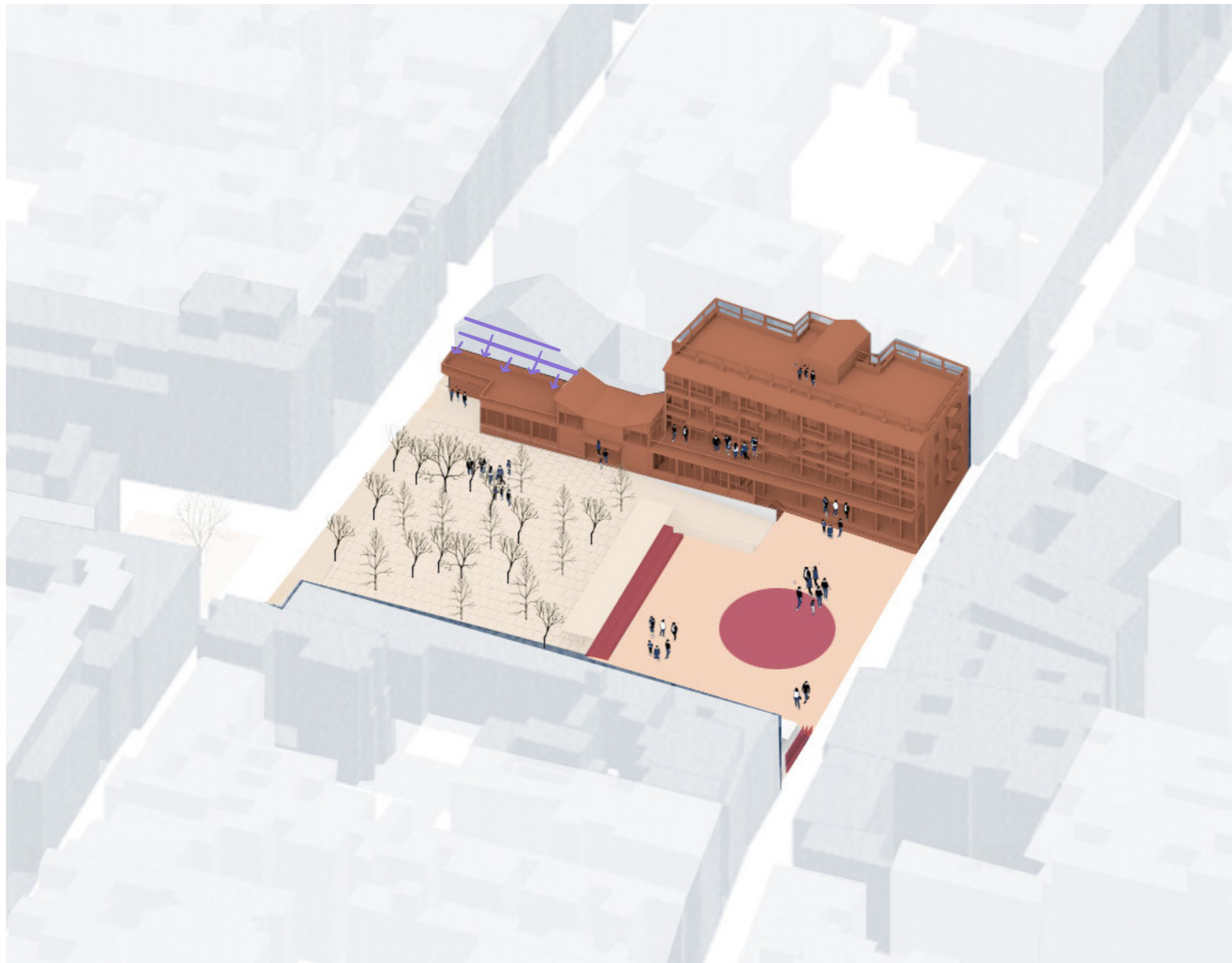



# Phasing

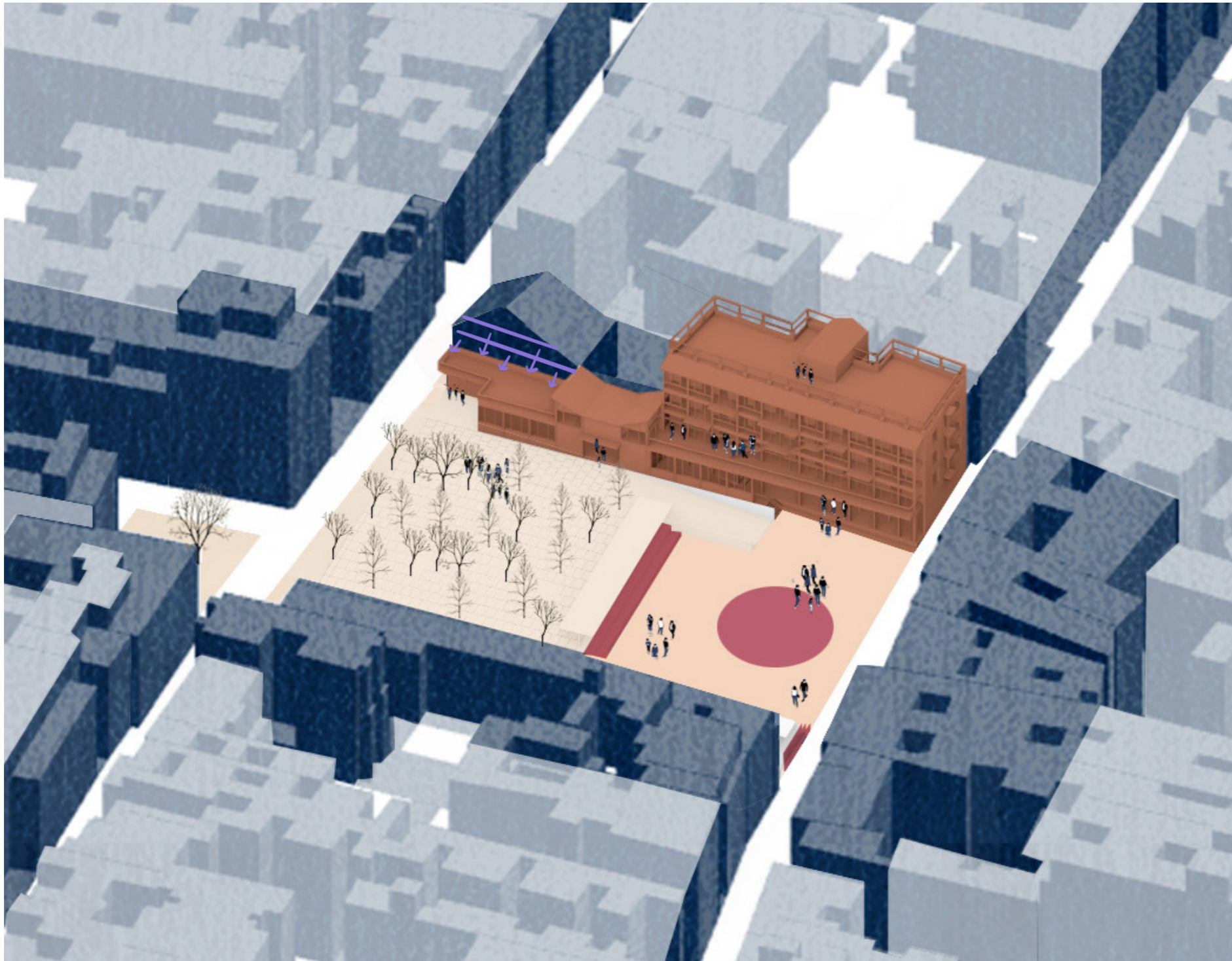



# The beginnings of Open Third Space

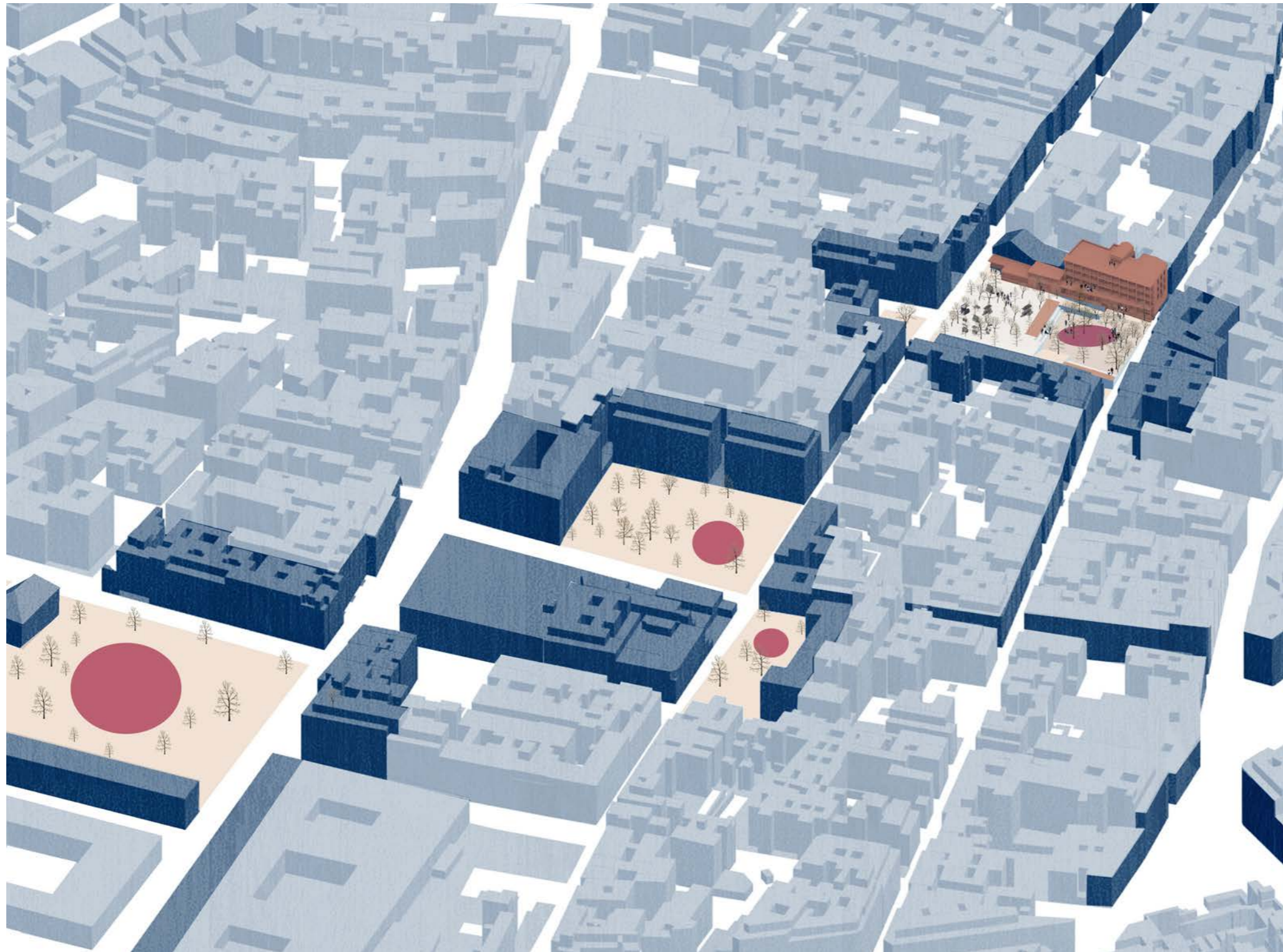



# An Open Third Space

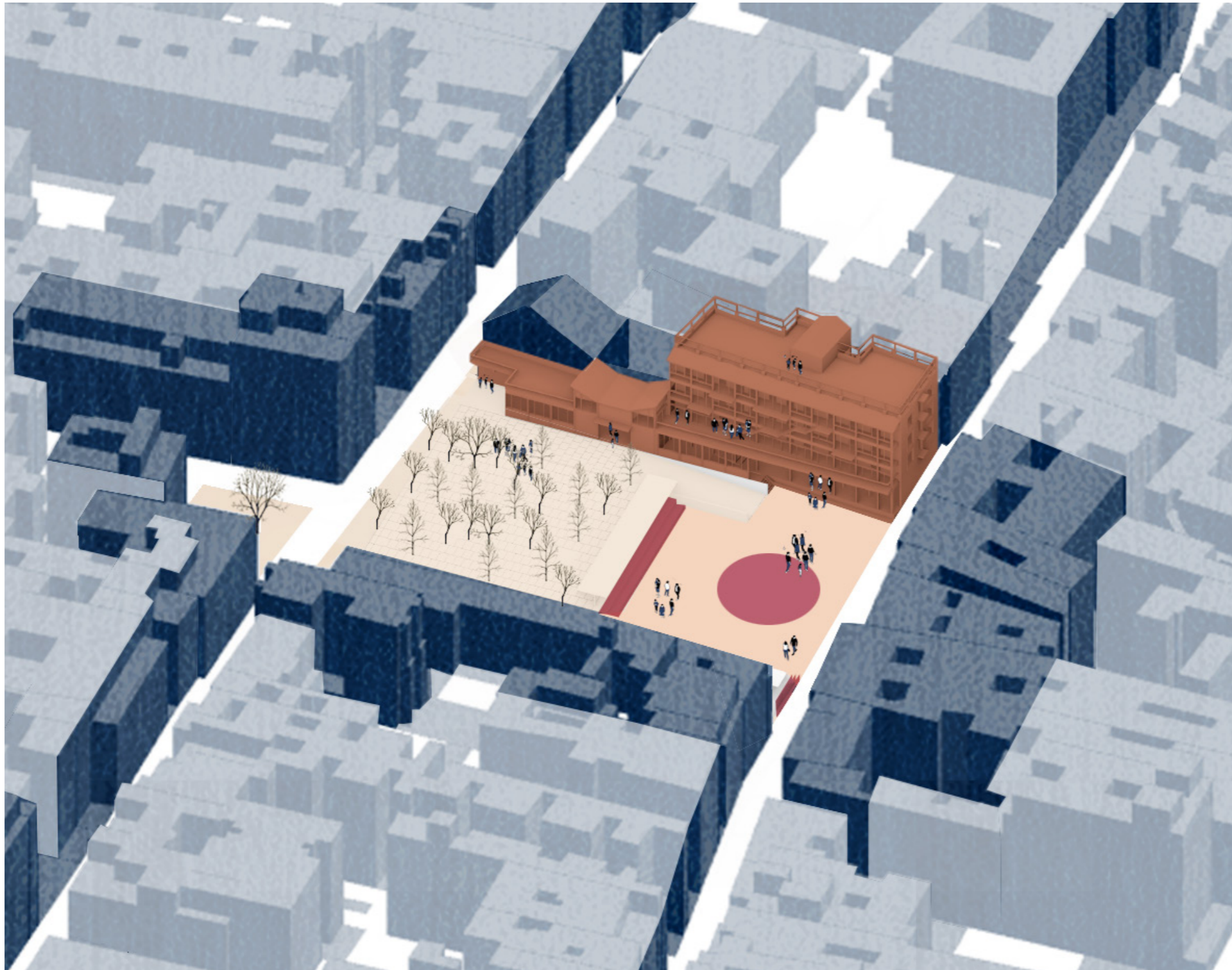



Thank you!

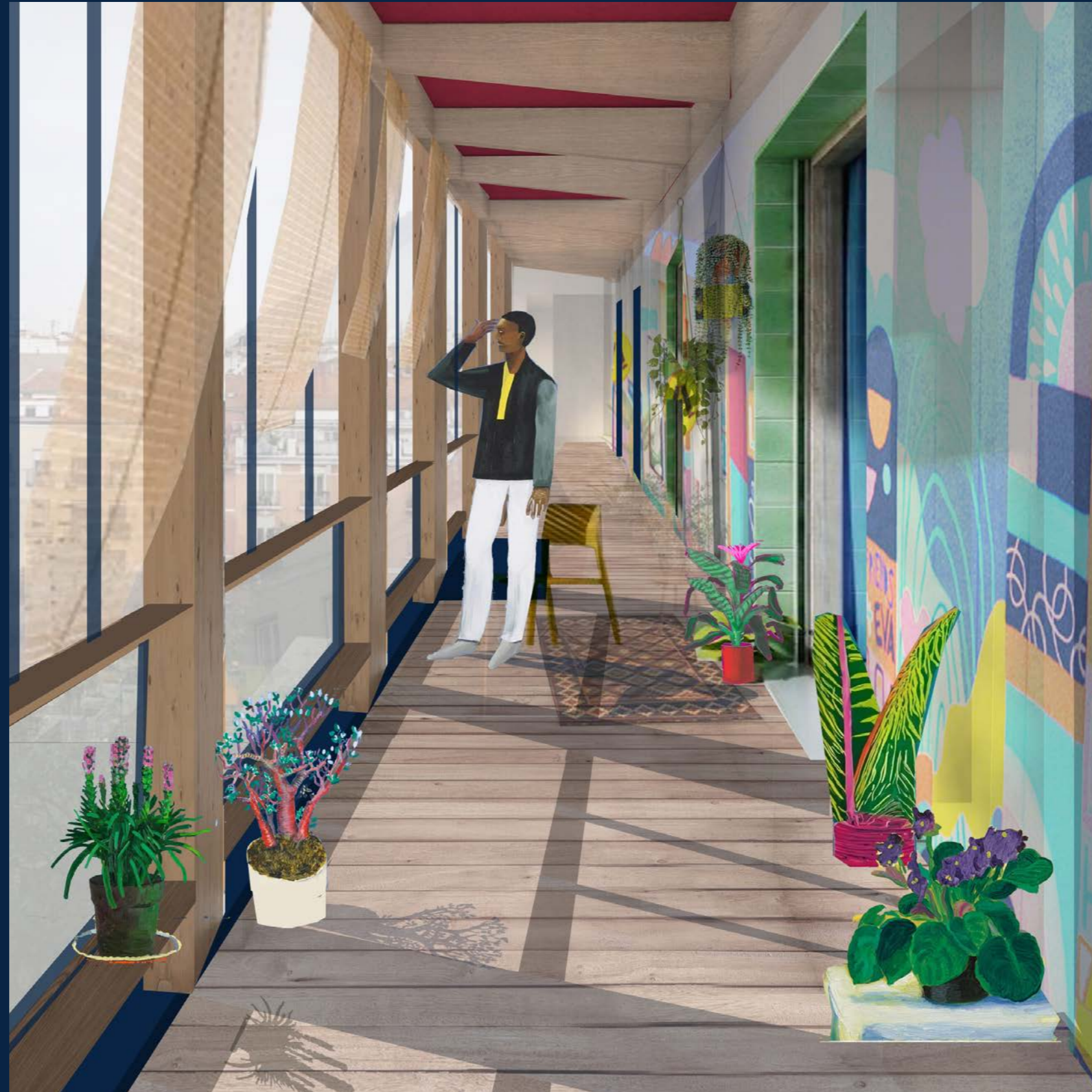



# Appendix



# Local Typologies







# Beginnings of a Double Skin

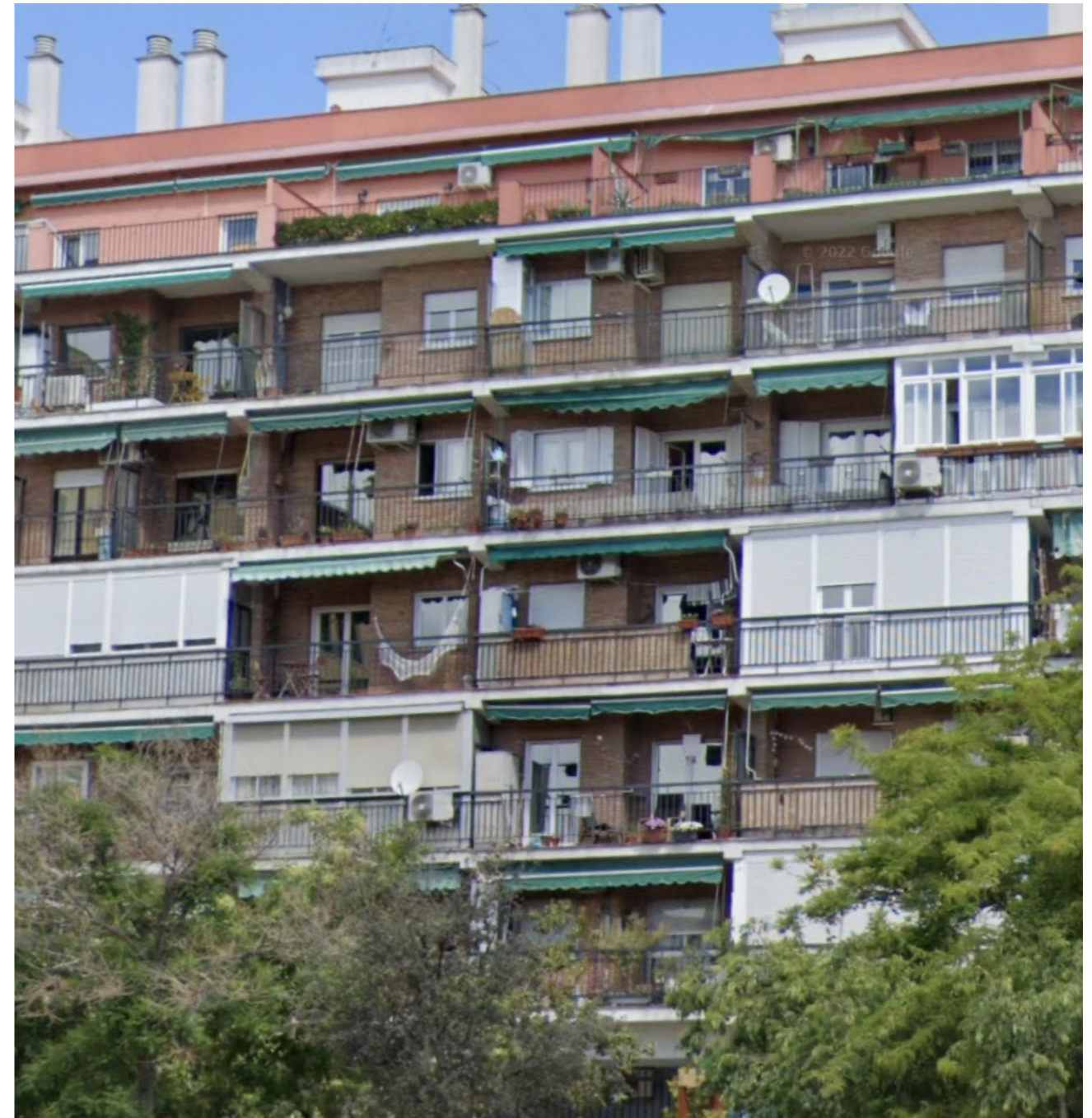



# Tapering Structure





# Customisable Balcony





# Local Facade Typologies - The Shutter

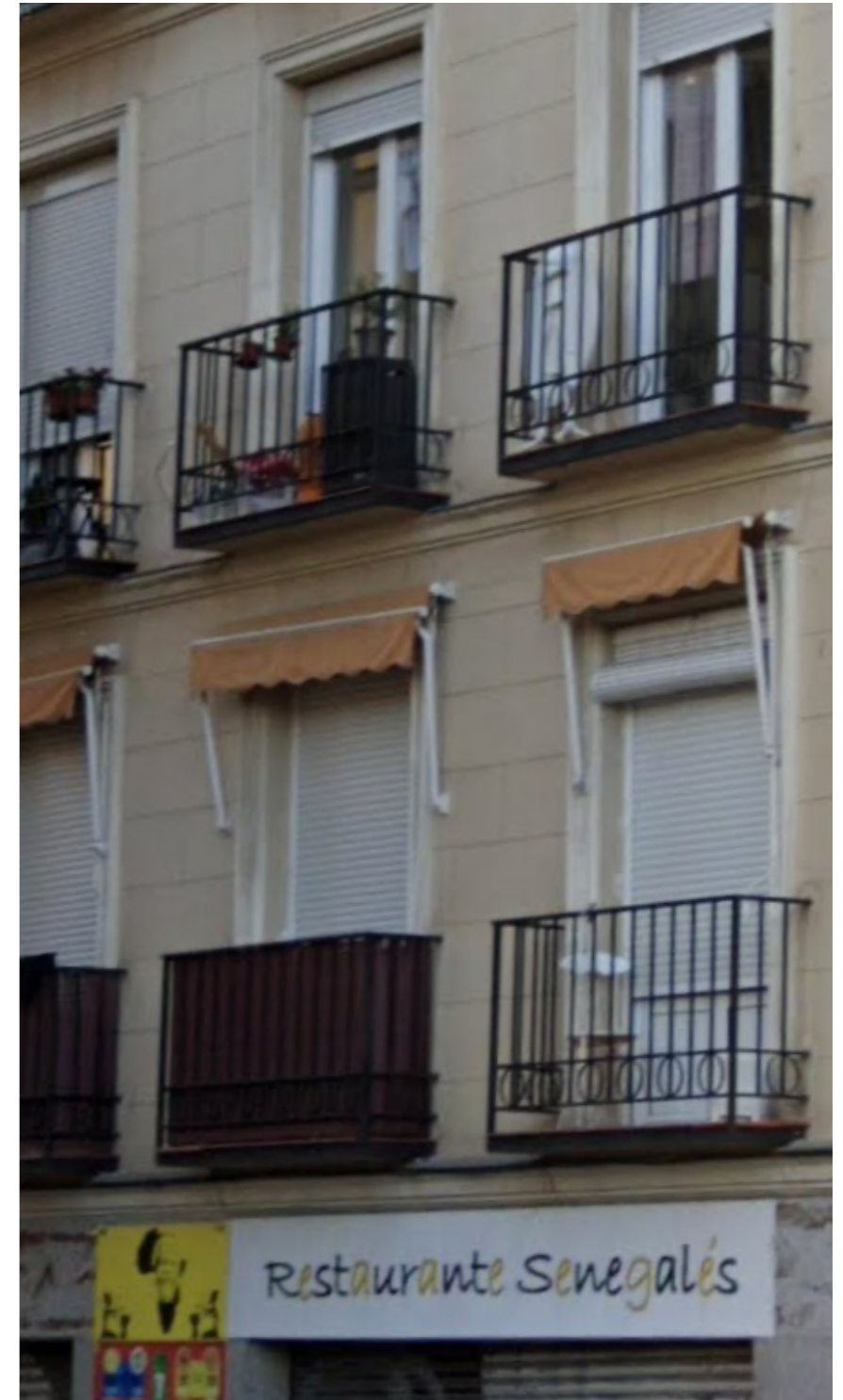



# Coloured Shutter Precedent - Seven Lives





# Balance of User Interventions





# Balance of User Interventions



A gathering in the ground floor of the reoccupied La Quimera building (Vigier, 2015)



CSROA La Quimera 2013



# Gutter Precedent - Hill Country Home Office





# Outdoor Pavilion Blind Precedent - Mediterraneo Pavilion





# Local Facade Typologies - The Plinth





# Windows as a grid

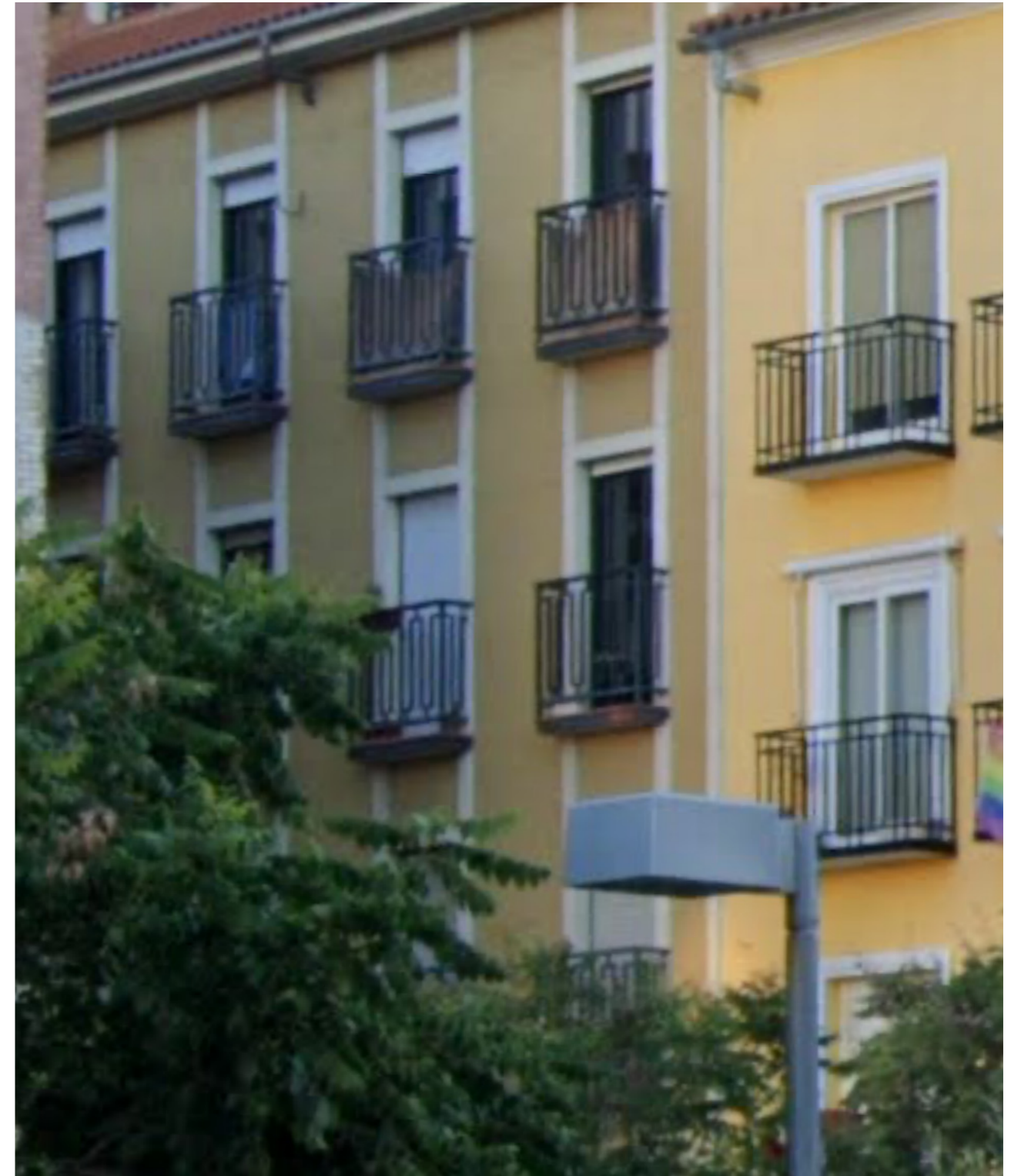



# Prominent Eaves

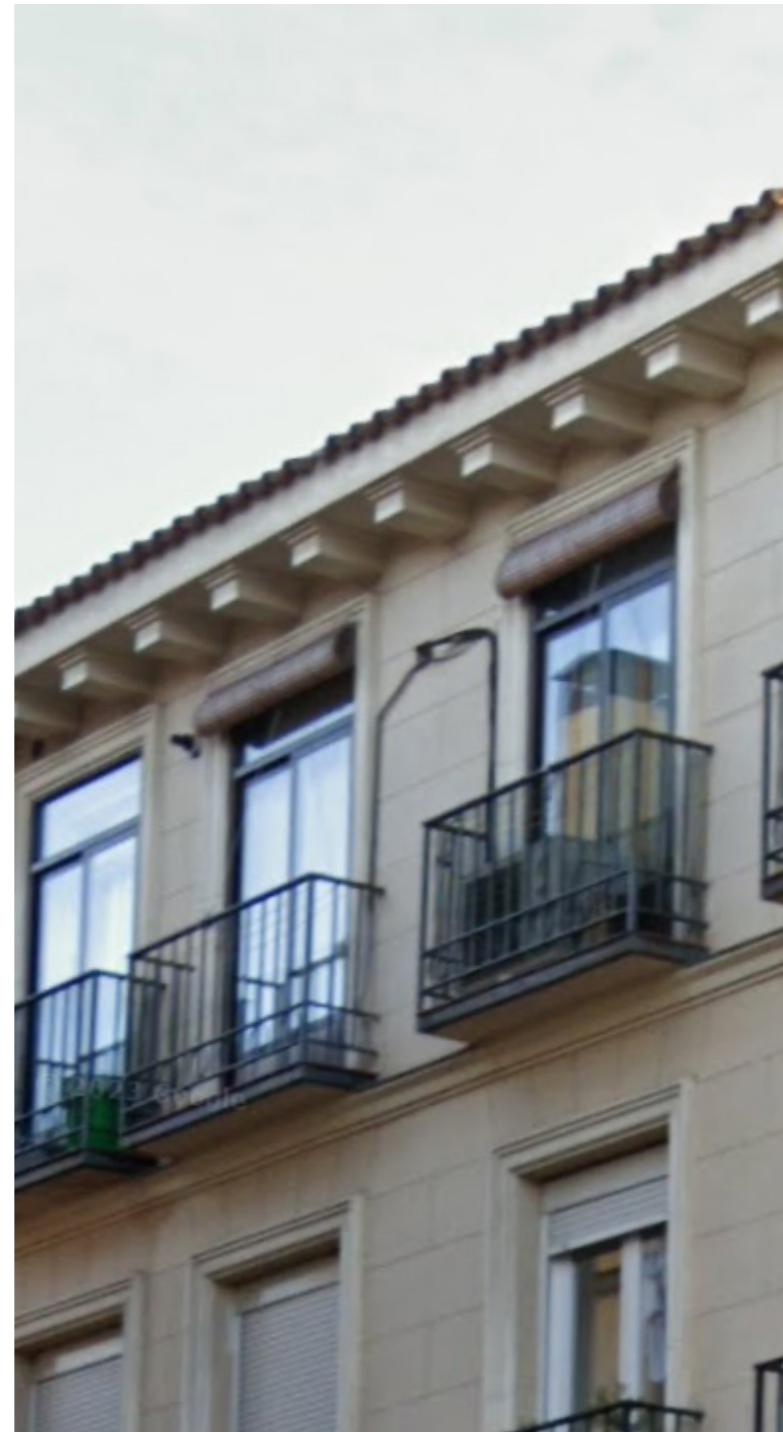
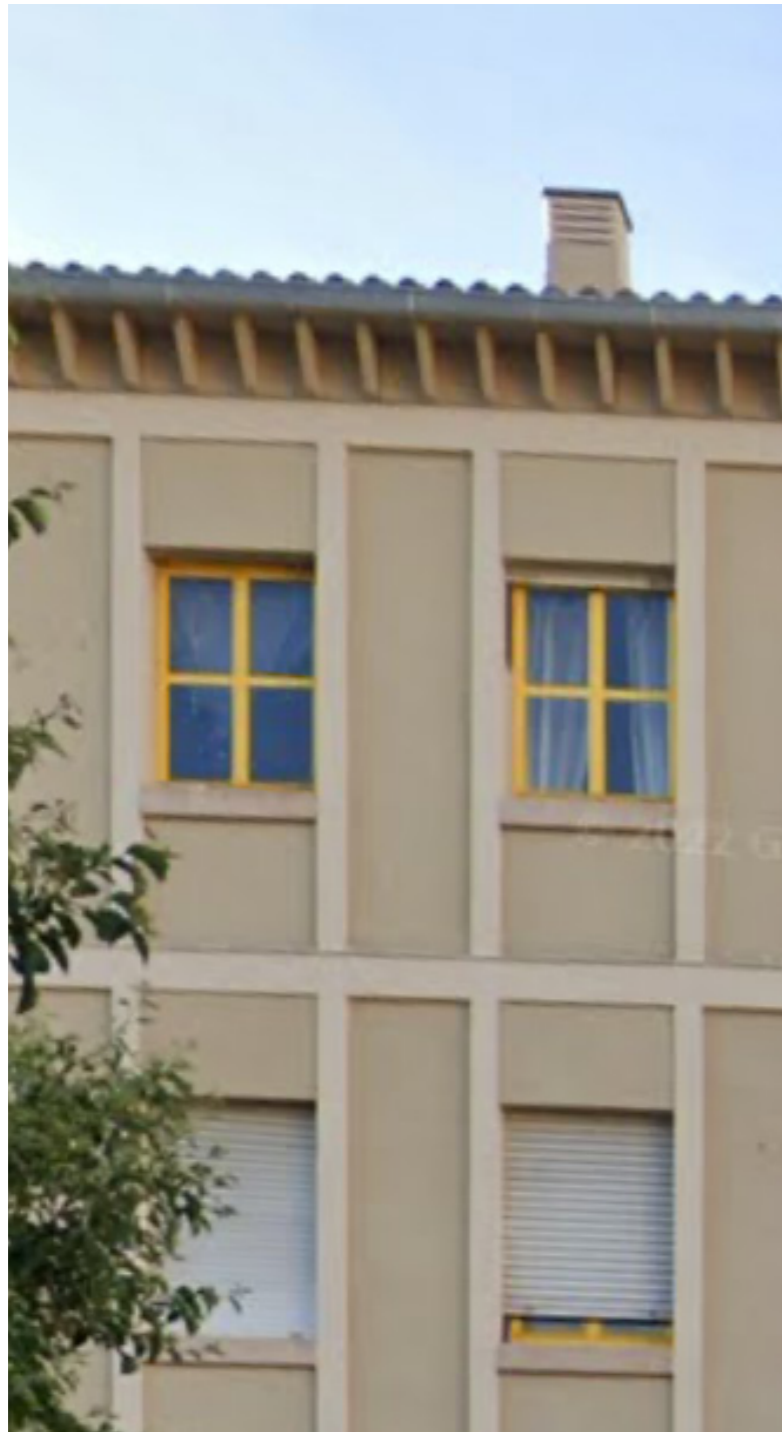



# Painted Shutters and Associations





# Colourful Walls

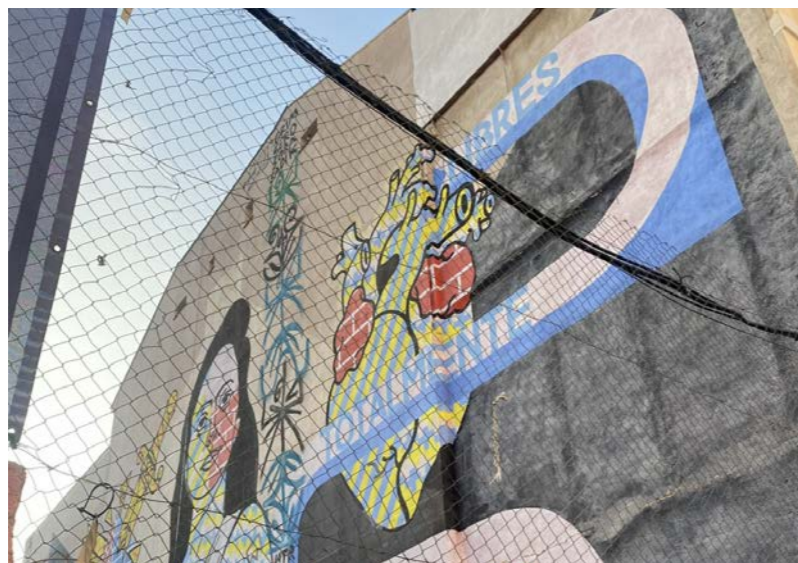



# Existing Buildings



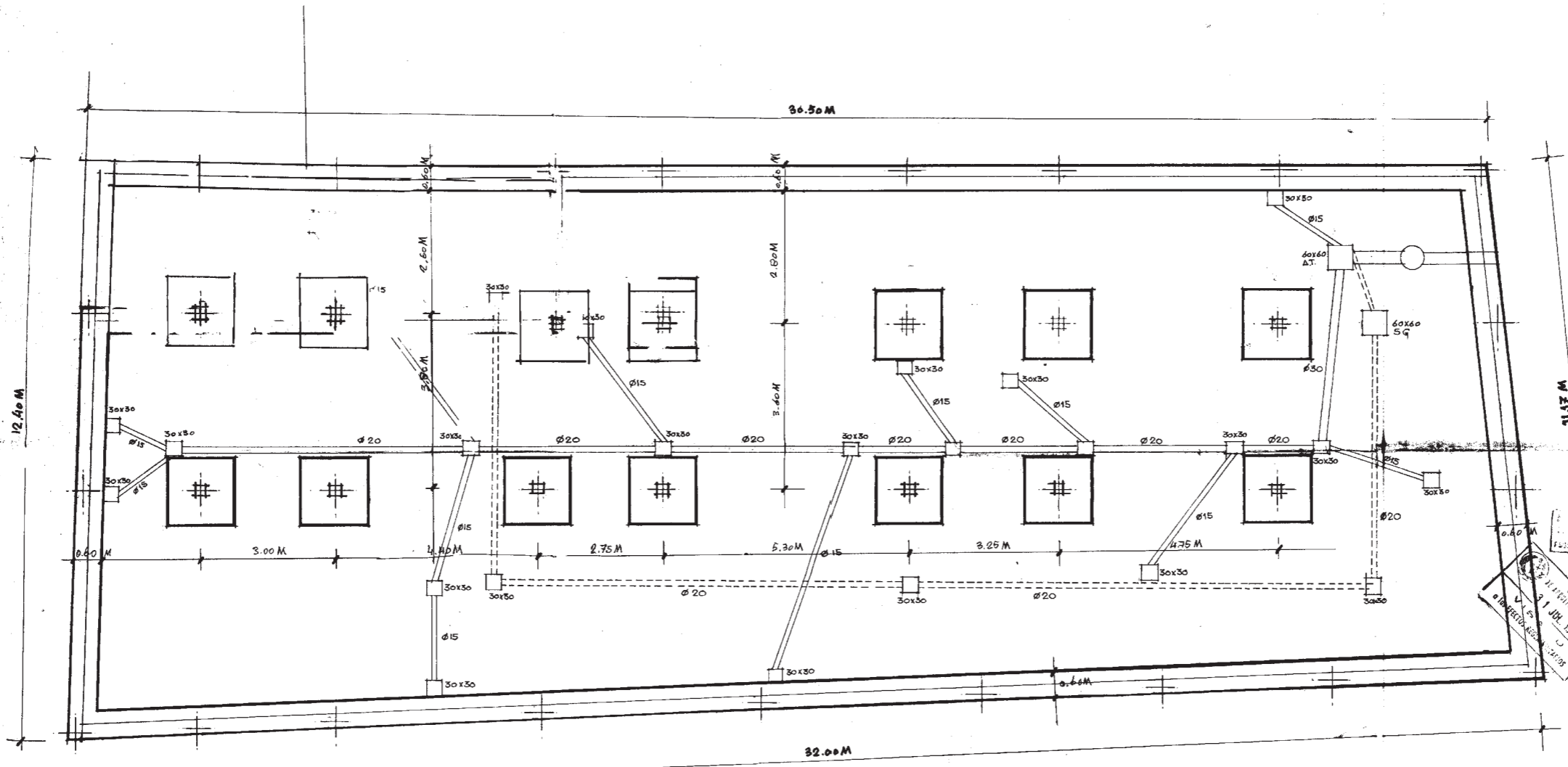

INVENTARIADO...  
 31 JUL 1974  
 PLANO APPROBADO ZONA H

Valen las correcciones...  
 30 de Julio de 1974  
 L. Fey

<b>OBRA:</b> PROYECTO DE EDIFICIO DE VIVIENDAS EN MADRID EN LA CALLE DEL AMPARO N° 24 PROPIEDAD: D. JOSE MUÑOZ SECA		PROYECTO N.º 4.195 PLANO N.º 2
L. Fey ARQUITECTO LUIS GONZÁLEZ GARCÍA	PLANTA DE CIMENTACION Y SANEAMIENTO ESCALAS: 1:50	JUNIO 1974 ANULA AL COMPLET. AL DELINEO



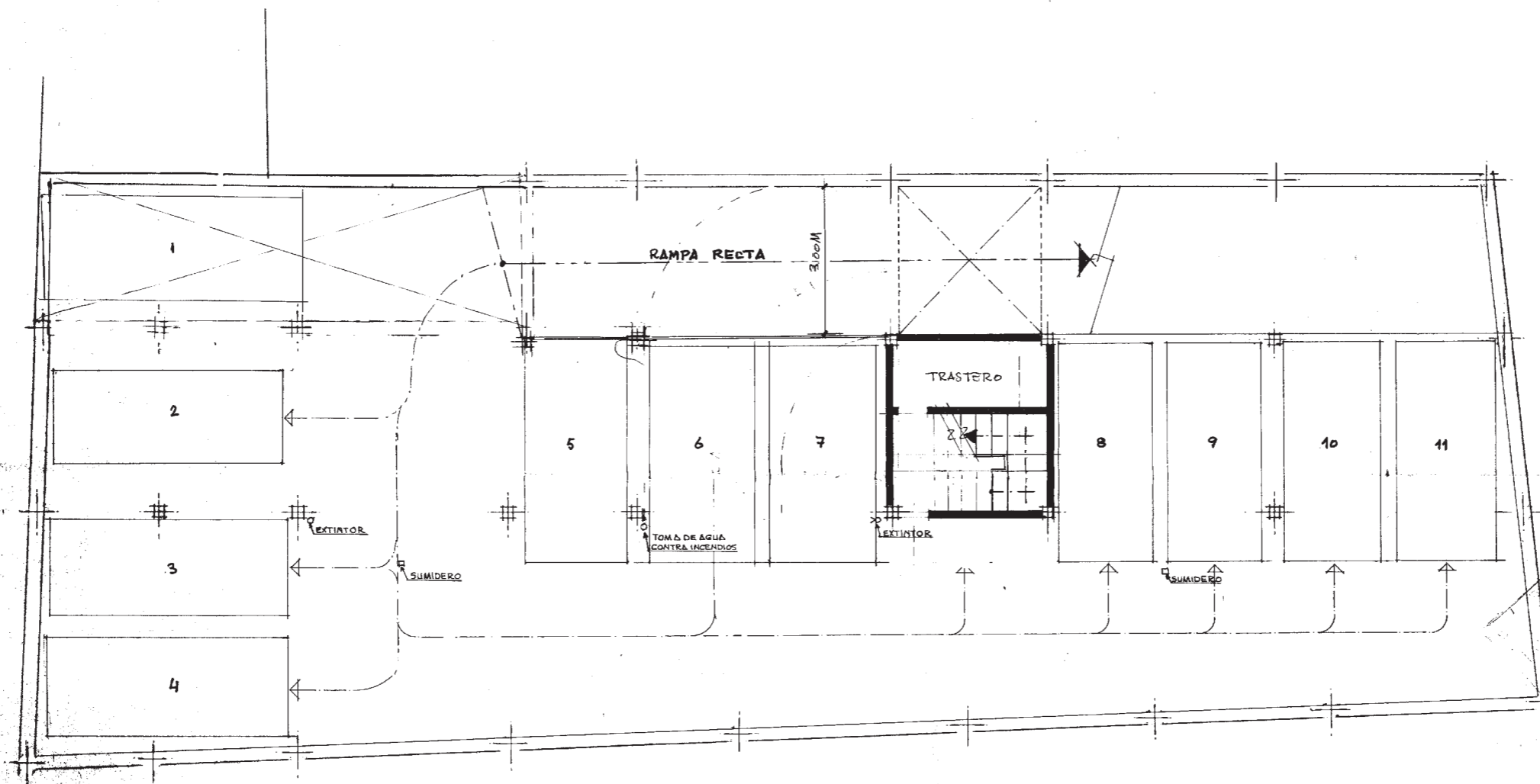

AYUNTAMIENTO DE MADRID  
 D.º de Urbanismo  
 Edificación  
 PLAN  
 APROBADO  
 ZONA I.

Valen los correctores  
 Madrid, D.º de Urbanismo  
 El Arquitecto

BRUCE  
 JUNIO 1974  
 6 NOV 1974

*García*

OBRA: PROYECTO DE EDIFICIO DE VIVIENDAS EN MADRID CALLE DEL AMPARO N.º 24		PROYECTO N.º 4195
PROPIEDAD: D. JOSE MUÑOZ SECA		PLANO N.º 3
<i>García</i>	PLANTA DE GARAJE	ANULA
		AL COMPLETAR
ARQUITECTO LUIS GONZALEZ GARCIA	ESCALAS: 1:50	JUNIO 1974
		DIRIGIDO



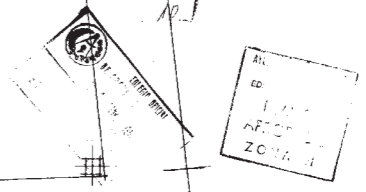
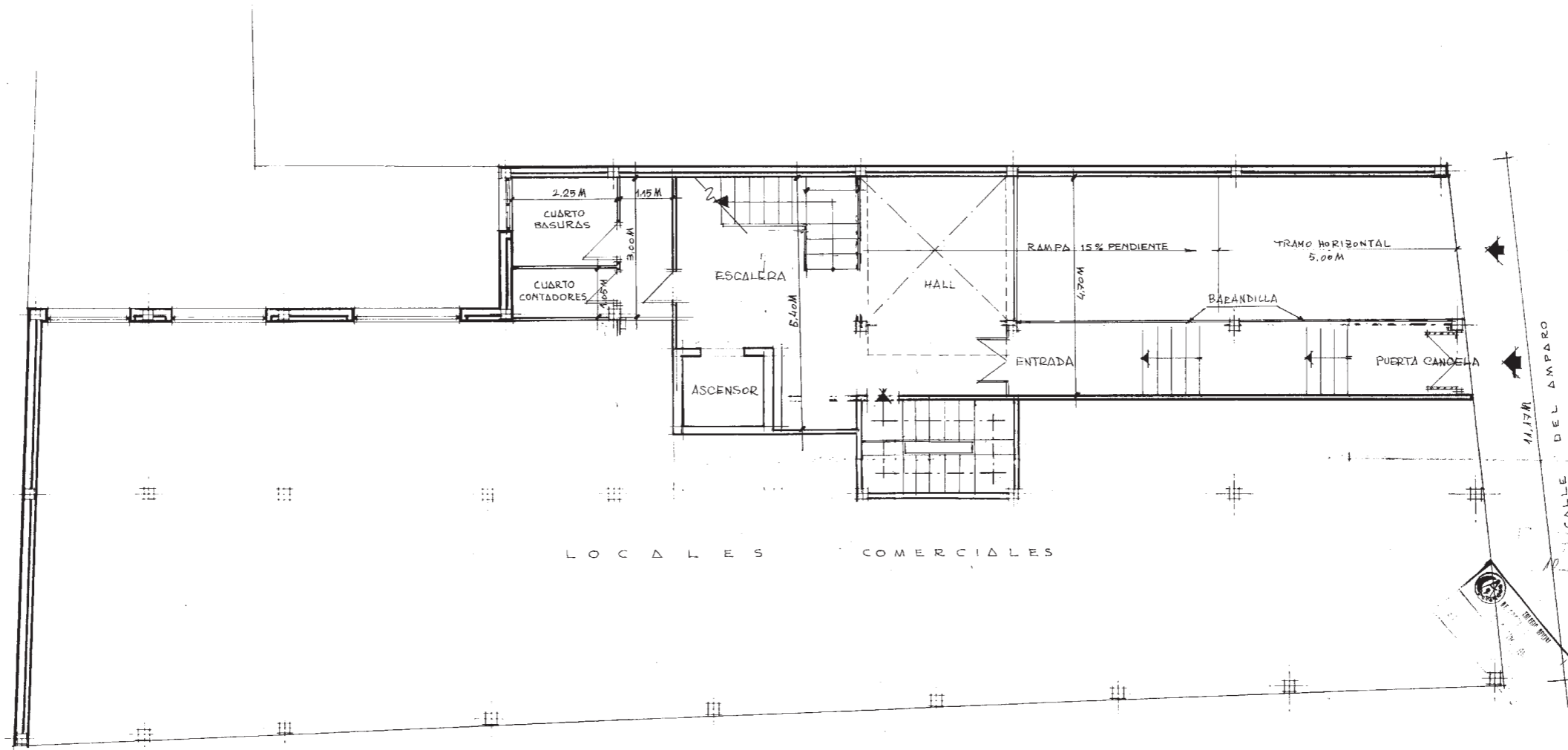

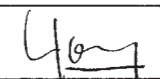
OBRA: PROYECTO DE EDIFICIO EN MADRID EN LA CALLE DEL AMPARO N° 24		PROYECTO N° 4.195
PROPIEDAD: D. JOSE MUÑOZ SECA		PLANO N° 4
 ARQUITECTO LUIS GONZALEZ GARCIA	PLANTA BAJA	ANULA AL
	ESCALAS: 1:50	JUNIO 1974
		DELINEO



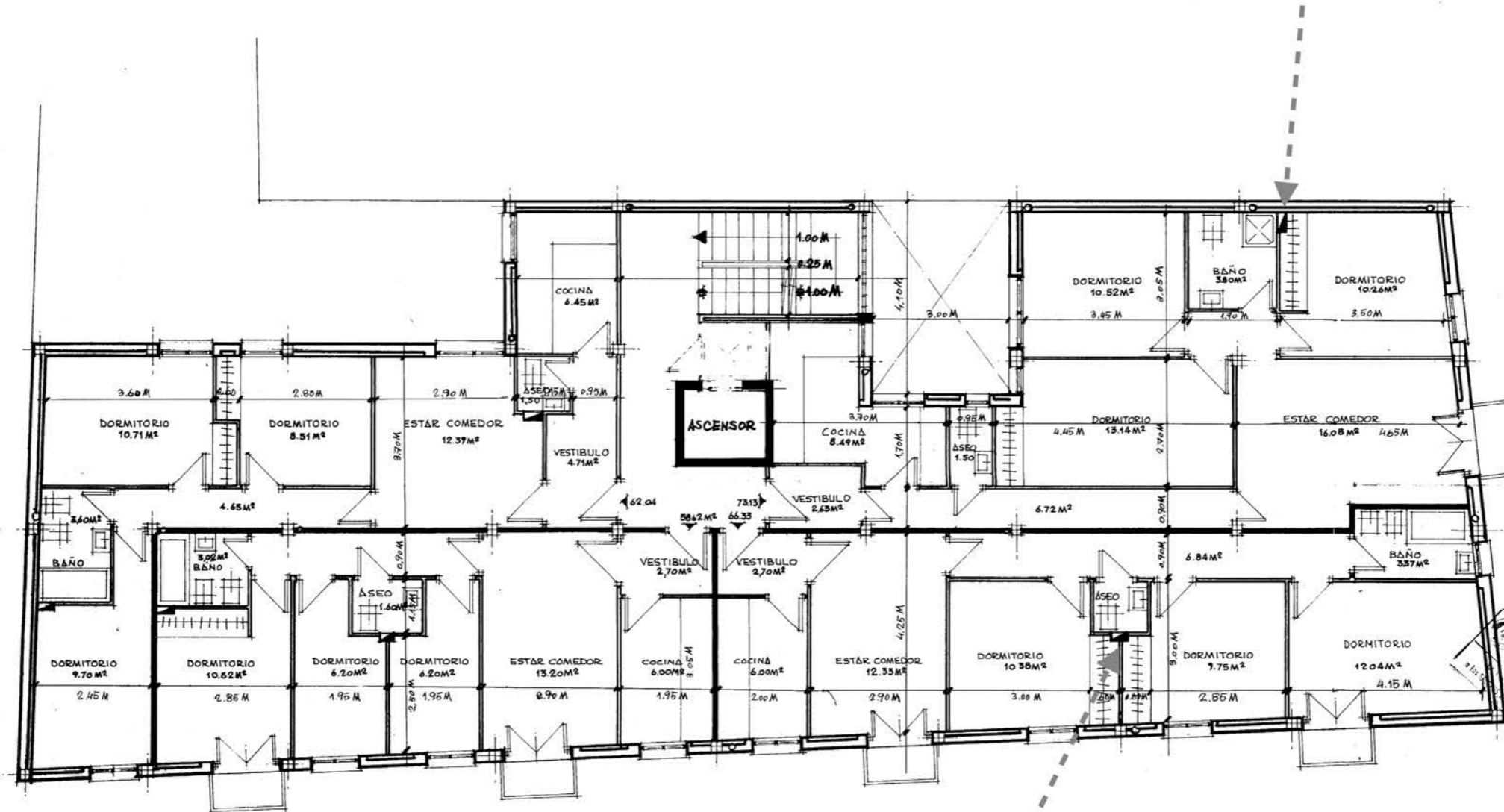

6 NOV. 1974  
 31 JUN 1974  
 PLANO APROBADO ZONA H  
 - 6 NOV. 1974  
 31 JUN 1974  
 407  
 98

<b>OBRA:</b> PROYECTO DE EDIFICIO EN MADRID EN LA CALLE DEL AMPARO Nº 24		PROYECTO N.º 4.195
<b>PROPIEDAD:</b> D. JOSE MUÑOZ SECA		PLANO N.º 5
407 ARQUITECTO: LUIS GONZALEZ GARCIA	PLANTA DE PISOS	ANULA AL
		COMPL. AL
ESCALAS: 1:50	JUNIO 1,974	DELINEO



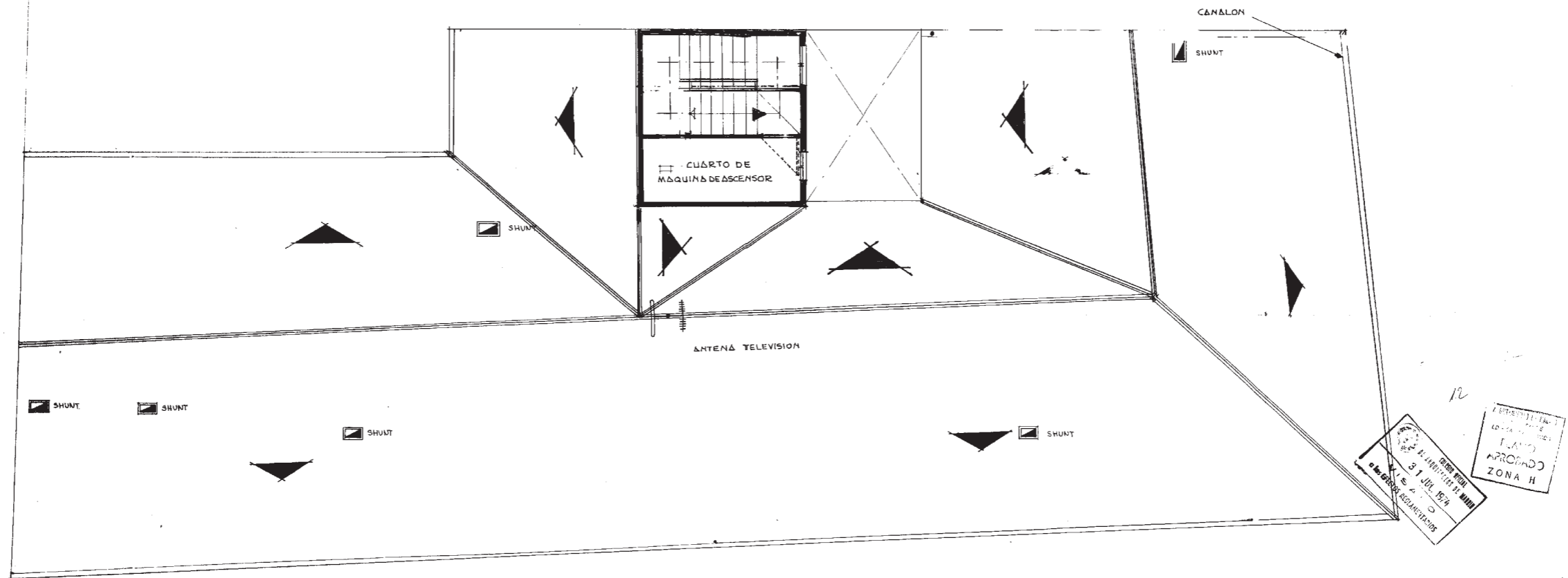

REVISADO POR:  
 EL INGENIERO EN ARQUITECTURA  
 31 JUL 1974  
 PLANO APROBADO ZONA H

6 NOV 1974  
 24  
 Goy

<b>OBRA:</b> PROYECTO DE EDIFICIO DE VIVIENDAS EN LA CALLE DEL AMPARO N° 24		PROYECTO N.º 4195
PROPIEDAD: D. JOSE MUÑOZ SECA		PLANO N.º 6
ARQUITECTO LUIS GÓNZALEZ GARCÍA	ESCALAS: 1:50	ANULA AL
		COMPLETA AL
JUNIO 1974		DELINEÓ



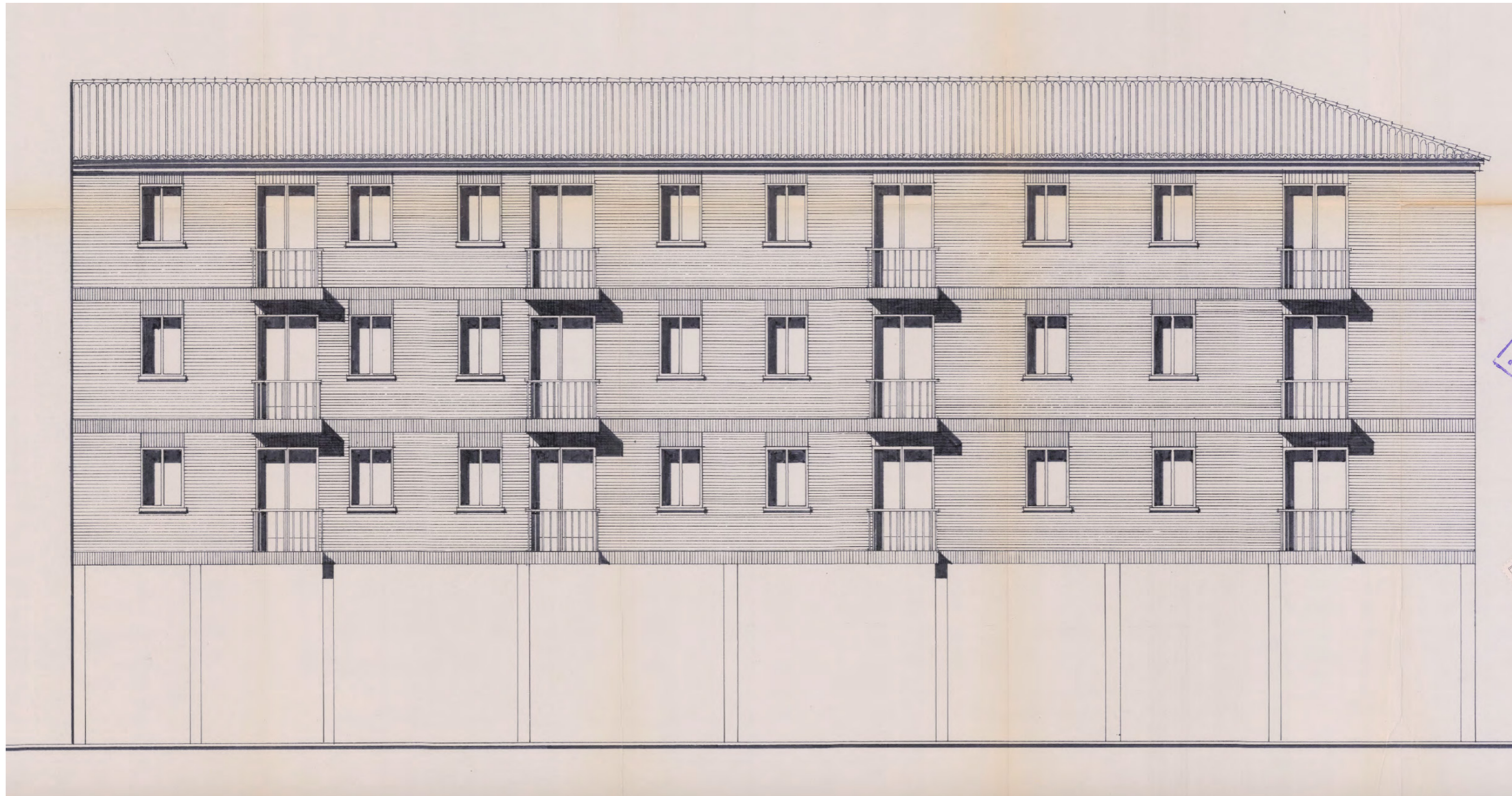



# La Quimera - Ground Floor





# La Quimera - Bedrooms



El interior del edificio de 'La Quimera' en Lavapiés que fue desalojado por la Policía Nacional y Municipal





# La Quimera - Facade

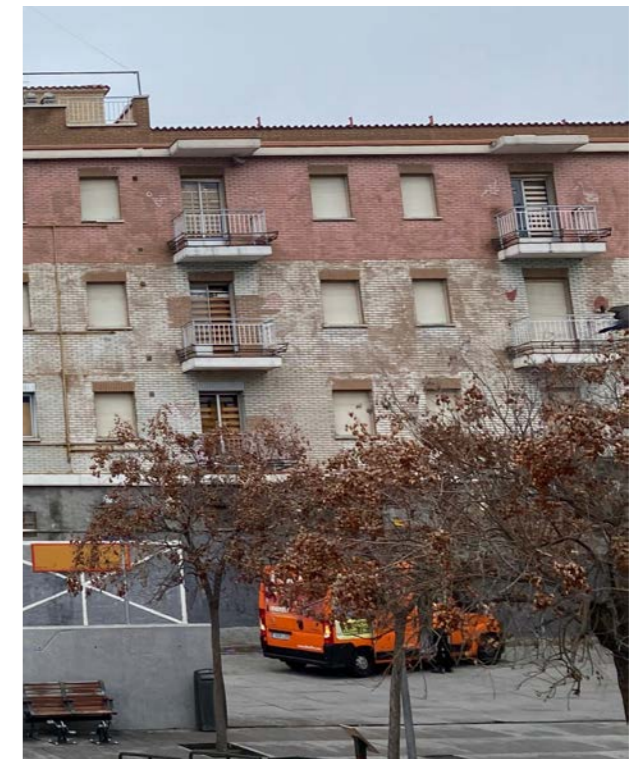
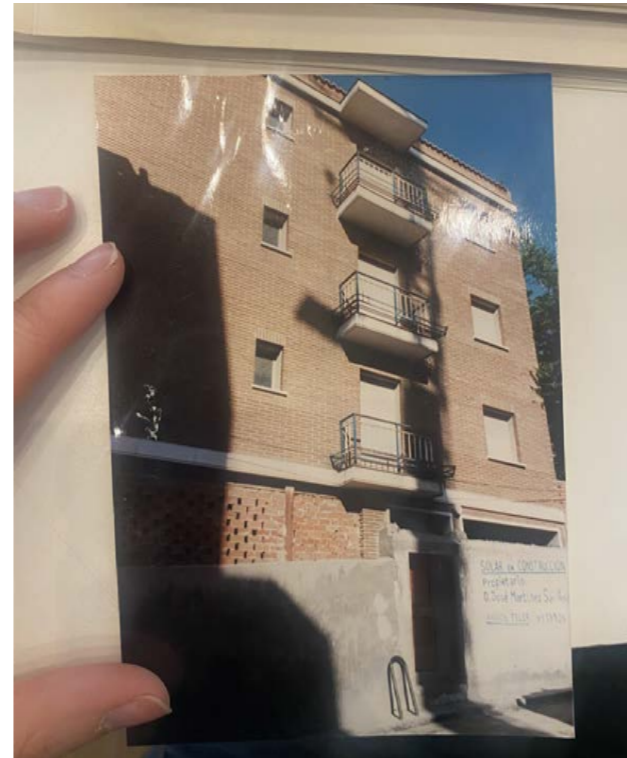



# La Quimera - Roof

