

Home of the  Innocent







Amsterdam — Rembrandtplein





# GROETEN UIT AMSTERDAM

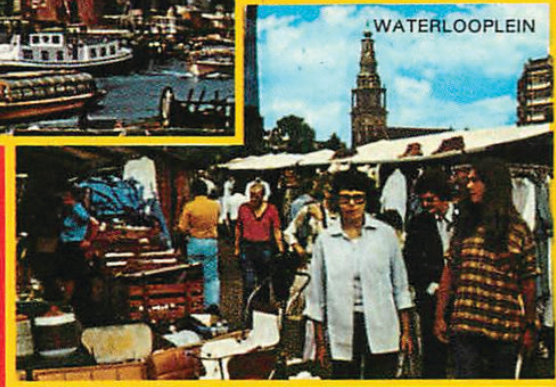









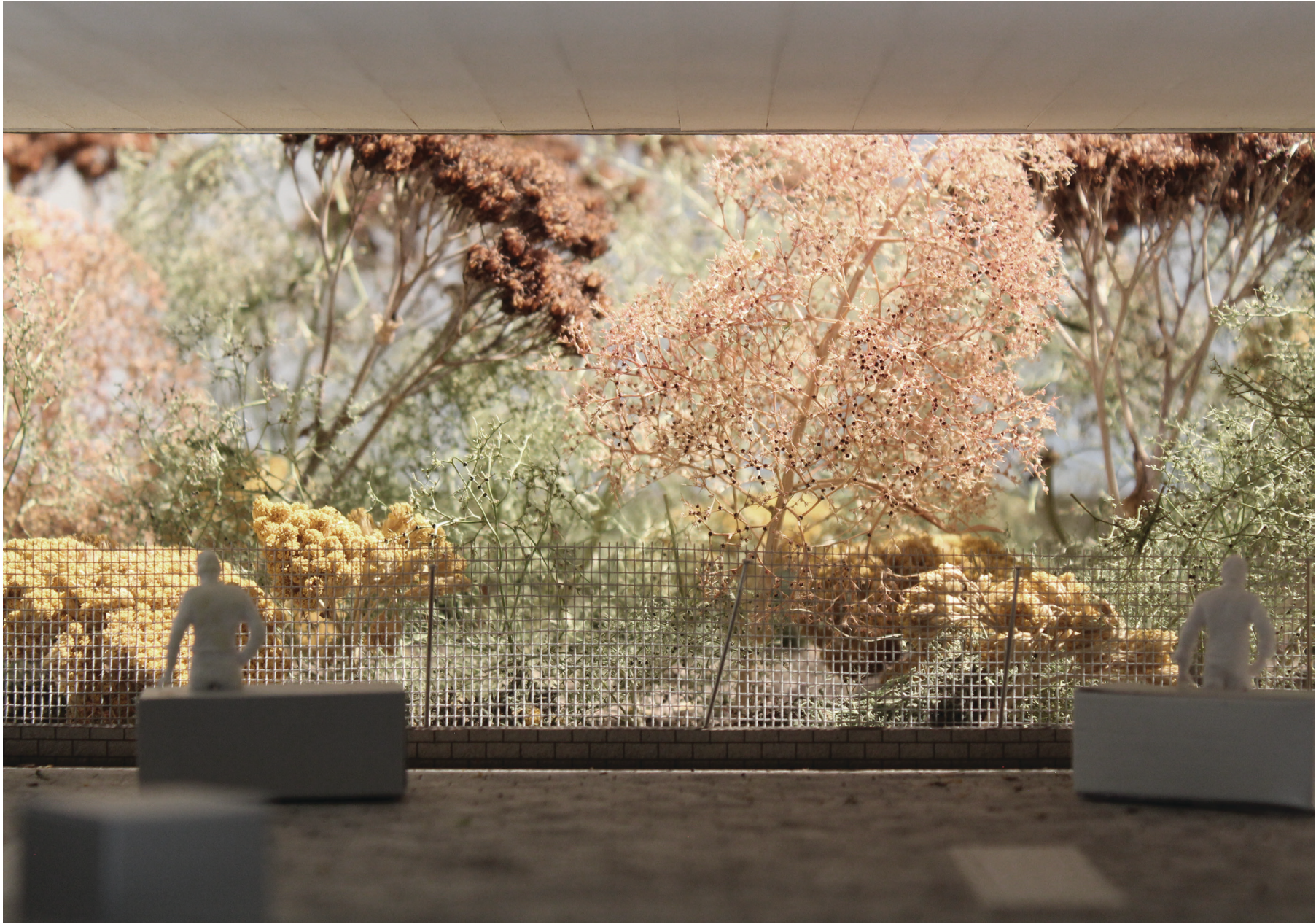

# القلب بيئكي والعين تبكي



**The heart moans , and the heart cries  
I used to dream of a universe filled with love  
Where there is no war, no violence, nor disputes  
Where everyone works to achieve there dreams  
And every generation enjoys calm and peace**

Manar Najim Abraham



**Tientallen doden, honderden doden...**

# IS HET NU GENOEG?

**BERT LANTING EN BARBARA DEUSSCHERE**  
**Honderden migranten zijn mogelijk verdronken toen een boot met vluchtelingen voor de kust van Libië kapseelde. 'Dit mag niet verbazen, want de versterkte operatie Triton volstaat echt niet. Ze richt zich te weinig op redder', zegt Bart Janssens van Artsen Zonder Grenzen, dat met een schip in de buurt helpt.**

Volgens AZG had de boot dit keer misschien wel 700 mensen aan boord. Ruim 400 van hen konden worden gered. Er zijn 25 lijken gevonden. Geveend wordt dat veel mensen de dood hebben gevonden in het ruim van het schip. Die plaatsen werden door mensensmokkelers doorgaan aan de minste draagkrachtige migranten verkeerde, vaak vrouwen en kinderen.

De overvolle boot zond een noodsignaal uit, nadat hij te buiten de territoriale wateren van Libië in de problemen was gekomen, vermoedelijk door de hoge golven. Toen een les marineschip, Le Numb,

de boot naderde en rubberboten uitzette, kapseelde het smokkelerschip doordat de opvarenden allemaal naar één kant begonnen te dringen.

Naast het les-schip namen ook de Dignity Leen-schip van Artsen Zonder Grenzen, en twee andere schepen deel aan de reddingsoperatie. Ook drie helikopters verleenden assistentie bij de pogingen zoveel mogelijk drevenelingen uit het water te halen. Tot diep in de nacht werd er nog naar overlevenden gezocht.

Maatschappelijk zal pas vandaag duidelijk worden hoeveel mensen het schip precies aan boord had, als de geredde opvarenden zijn verhoord. Een aantal van hen zou waarschijnlijk aankomen in Palermo op Sicilië.

**Vluchtelingen**  
 Dit jaar zijn er volgens de VN-vluchtelingenorganisatie UNHCR al ruim tweehonderd mensen verdronken tijdens een poging in de Middellandse Zee over te steken. Veruit het grootste deel van hen komt een op de twee naar Italië en Malta vanaf de noordkust van Afrika. Ook Griekenland krijgt veel bootvluchtelingen te verwerken, hoofdzakelijk vanuit

**De boot zou wel 700 mensen aan boord hebben gehad, 400 van hen konden worden gered**

Turkije. Maar deze route is veel minder risicaal. In deze regio zijn voor zover bekend minder dan honderd bootvluchtelingen ontkomen op zee.

Dit is waarschijnlijk de opzet ramp sinds april, toen een boot met ruim 700 migranten vlak voor de kust van het Italiaanse eiland Lampedusa kapseelde. Slechts 28 mensen overleefden de schipbreuk. Een half jaar hadden de EU-landen de reddingsoperaties op een laag pitje gezet uit vrees dat de alleen maar een aanzetgevoel op de stroom bootvluchtelingen zouden hebben.

Maar na de ramp bij Lampedusa zegden de EU-leiders extra schepen en financiën toe voor Triton, de nieuwe zoek- en reddingsoperatie in de

Middellandse Zee. In totaal trokken de EU-leiders 120 miljoen euro uit om de kosten van de operatie tot eind 2016 te dekken.

**Belofte niet ingelooft**  
 Volgens Bart Janssens van AZG kost Triton de belofte echter niet in. "De militaire schepen zijn eerder op bewaking dan op redder gericht. Wij zijn een ops en redder sinds april al meer dan 10.000 mensen en de opvangcentra zitten zo vol dat we niet meer moeten leunen". De Internationale Organisatie voor Migratie meldt bovendien dat sommige landen die militaire schepen ook afweer terugtrekken.

De afgelopen tijd raakten de risicante overtochten over de Middellandse Zee enigzins op de achtergrond door een verwaarloosde poging van migranten bij Calais om aan boord te komen van vrachtwagens en treinen op weg naar Groot-Brittannië. Maar alles wijst erop dat de stroom bootvluchtelingen die naar Italië proberen over te steken, nauwelijks is afgenomen. Nog afgelopen maandag redden de Italiaanse kustwacht 300 opvarenden van een smokkelboot. ► 2, 4-5

**Mademoiselle of Madame?**  
**Halina Reijn:**  
 'Een meneer is al een meneer als hij wordt geboren'

► 11

## Angstzweet bij top Republikeinen

Deze nacht kruisen de Republikeinse presidentskandidaten voor het eerst rechtstreeks de degens in een tv-debat op de conservatieve zender Fox News. Die zonder bezoot om uiteindelijk tien kandidaten te selecteren op basis van de vijf recentste landelijke peilingen. Daardoor vielen kandidaten Rick Perry en Rick Santorum uit de boot, die nochtans in 2008 en 2012 prominente kanshebbers waren. De ogen zijn nu gericht op Donald Trump. De celebrity-voetballer ontzette zich de voorbije weken te favoriet in een aantal peilingen. Ondanks, of net dankzij, aangebrachte uitspraken over Mexico en emigranten.

En dat baart het establishment van de Republikeinen ernstig zorgen. Zij hopen dat uiteindelijk Jeb Bush - broer en zoon van twee oud-presidents - het opvoert tegen Hillary Clinton in de algemene verkiezing. Als Trump de Republikeinse nominatie binnenhaalt, kunnen ze de herovering van het Witte Huis op hun baai schrijven. Voorlopig lijkt die kans klein. Alleen blijft hij wel langer in de race als hij versmacht een goede beurt maakt in het debat. Bovendien bestaat de kans dat hij alomtegenwoordig kandidaat naar de stembus trekt, waardoor de Republikeinse stemmen verdeeld dreigen te geraken. "Het establishment zal last hebben van de peilingen-macht", zegt de Nederlandse Amerika-kenners Willem Post, senior fellow bij het prestigieuze Instituut Clingendael. "Daar kun je giff op inmenen." **HA/VO**  
 ► FOCUS 17-18

**A place that is welcoming, that feels like a home, a place where one can interact or withdraw, that cares and nurtures, that protects and stimulates, a place that provides hope to children that are currently without any. A home to the innocent.**

























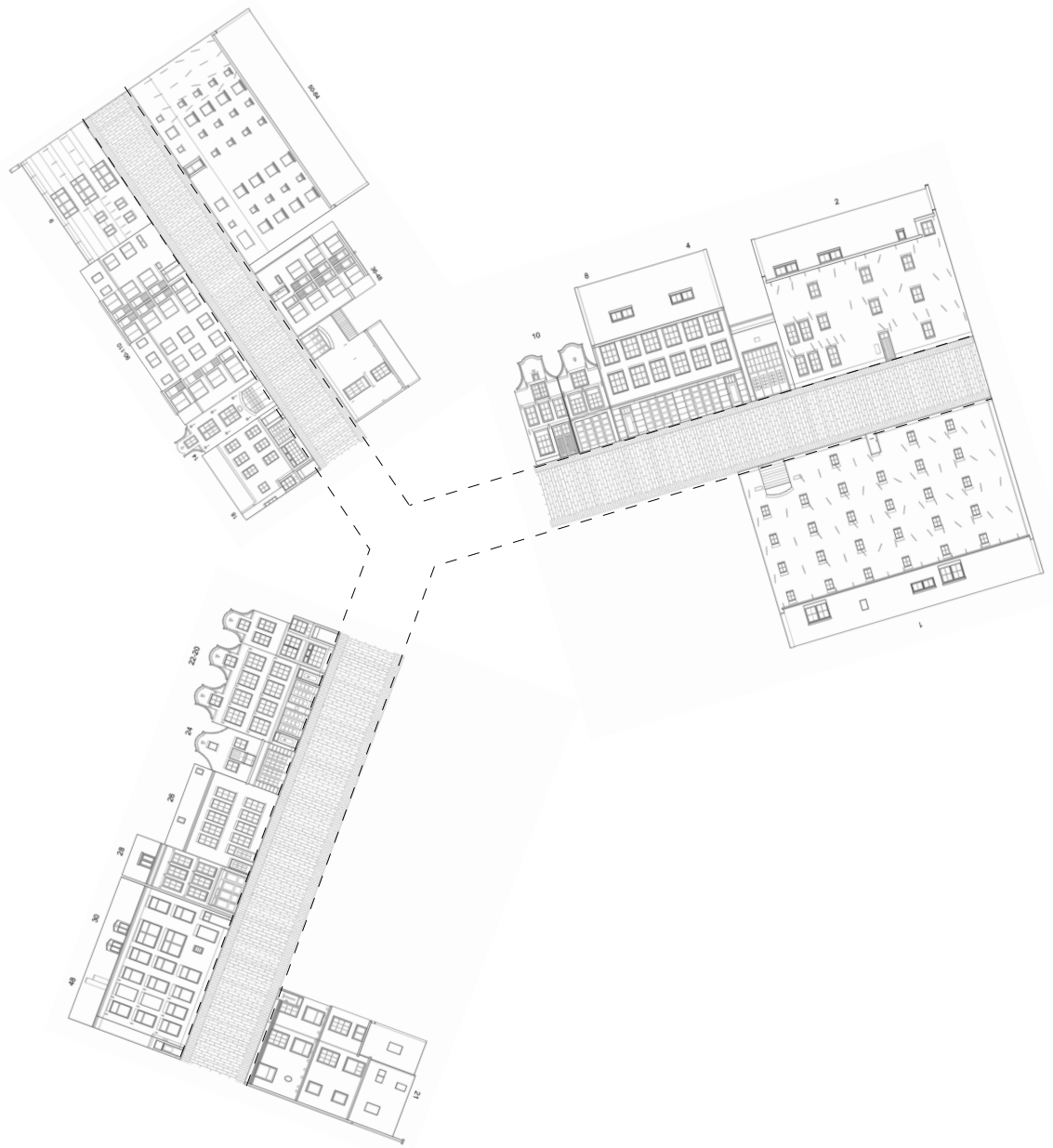

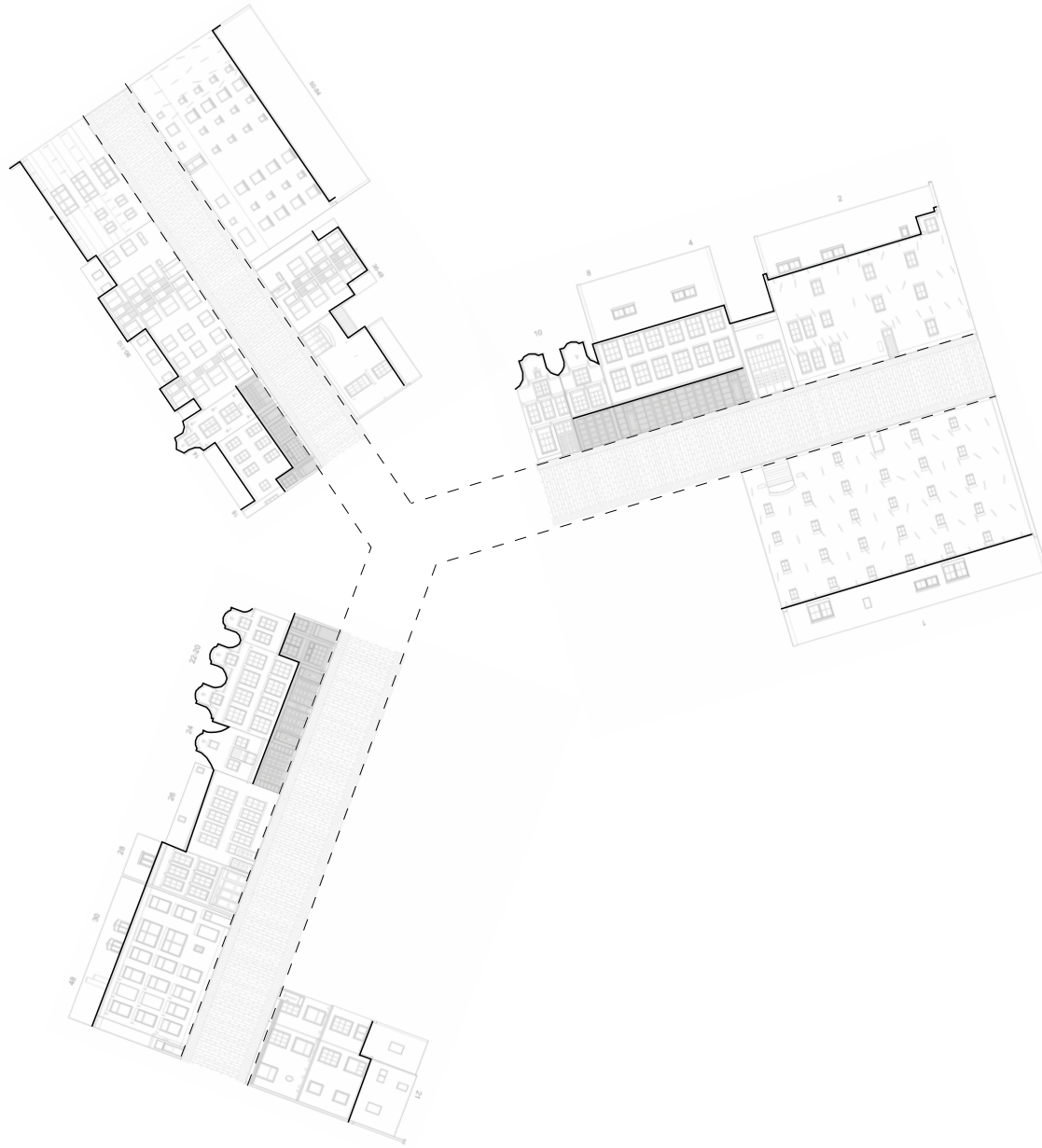

### **Opportunities...**

Reivive the urban void and use the courtyard as a central role in the plan

Reinforce the character of the three legged street by completing the block

Add to the palette of textures, colour and verticality in the street

**To offer the children the prospect of a brighter future, the building sets out to create a safe and protective environment, one that allows them to withdraw and cope with trauma, but also presents means to build new relationships and interaction with the child's new setting.**

## **Public**

Nursery 12 kids  
After School Care 30 kids  
Office for Adoption

## **Private**

Accommodation 18 kids  
Communal Spaces  
Principle's Apartment

## **Exterior**

Courtyard for the Nursery  
Courtyard for the After School Care  
Roof Terrace

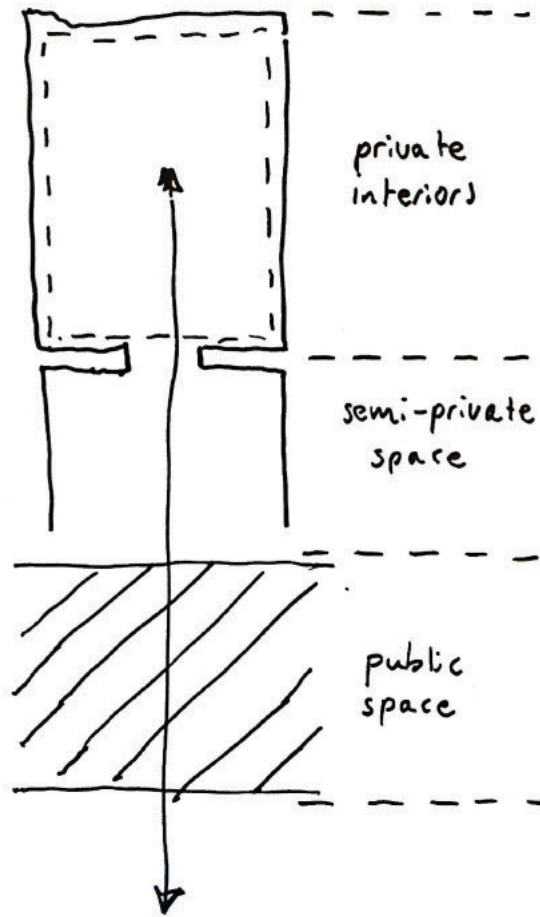

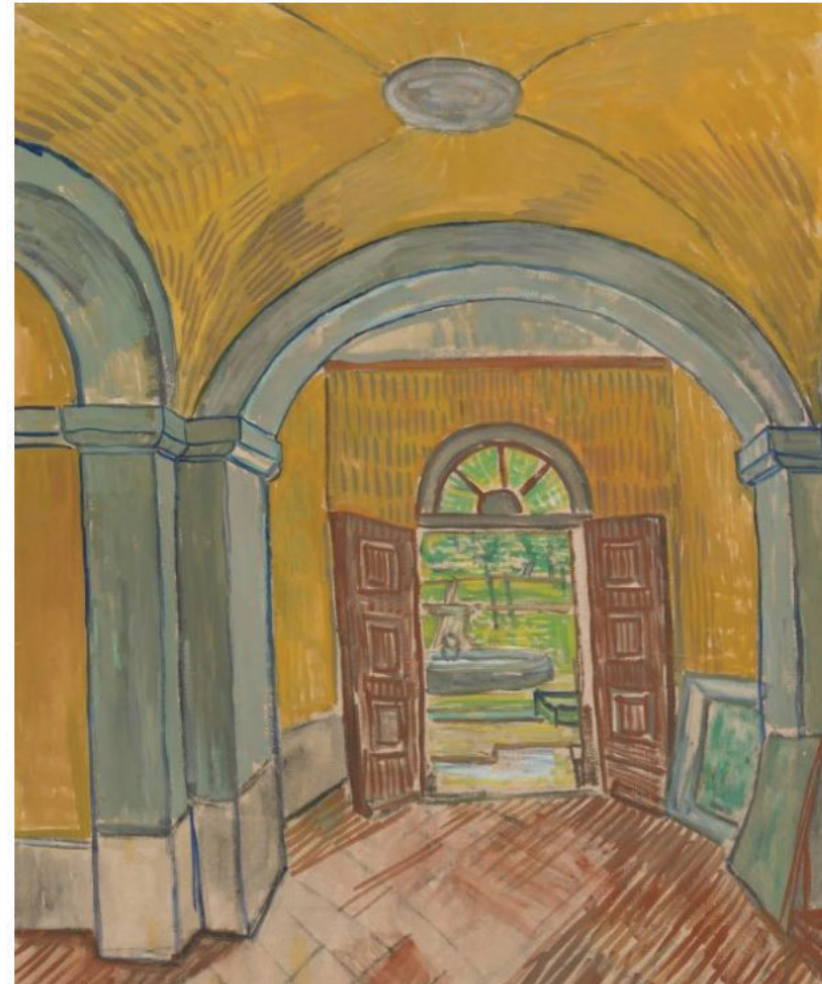
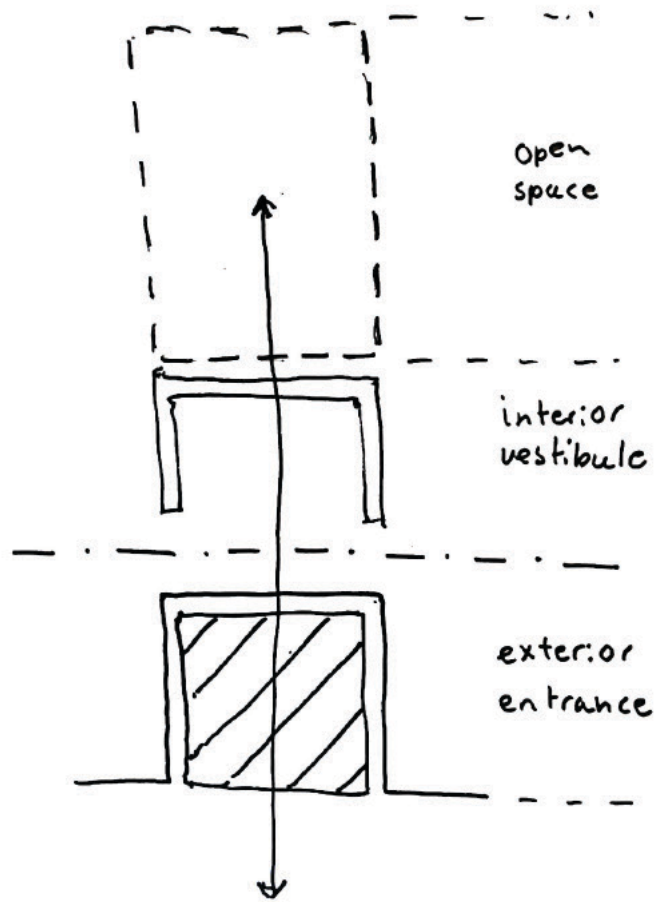

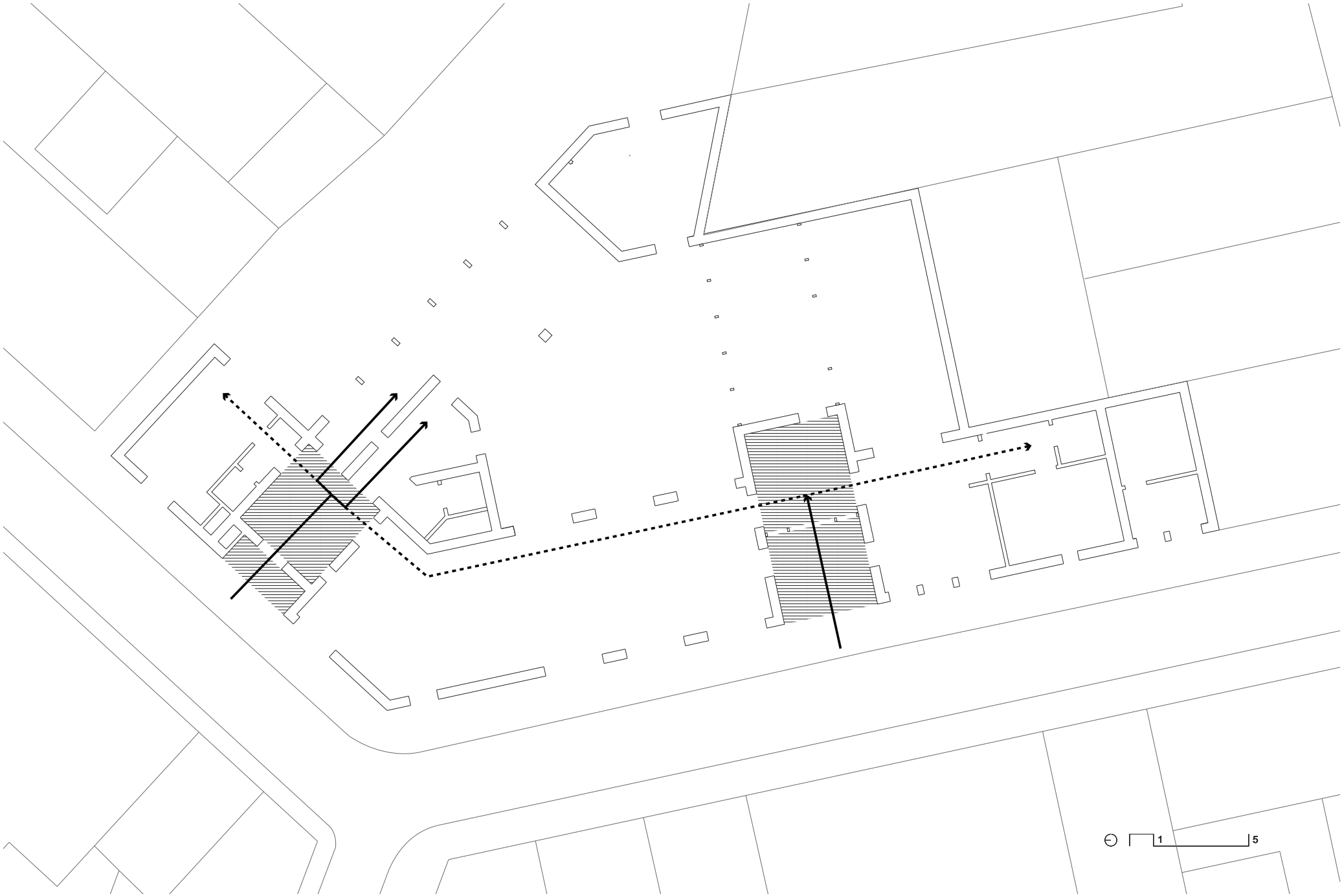







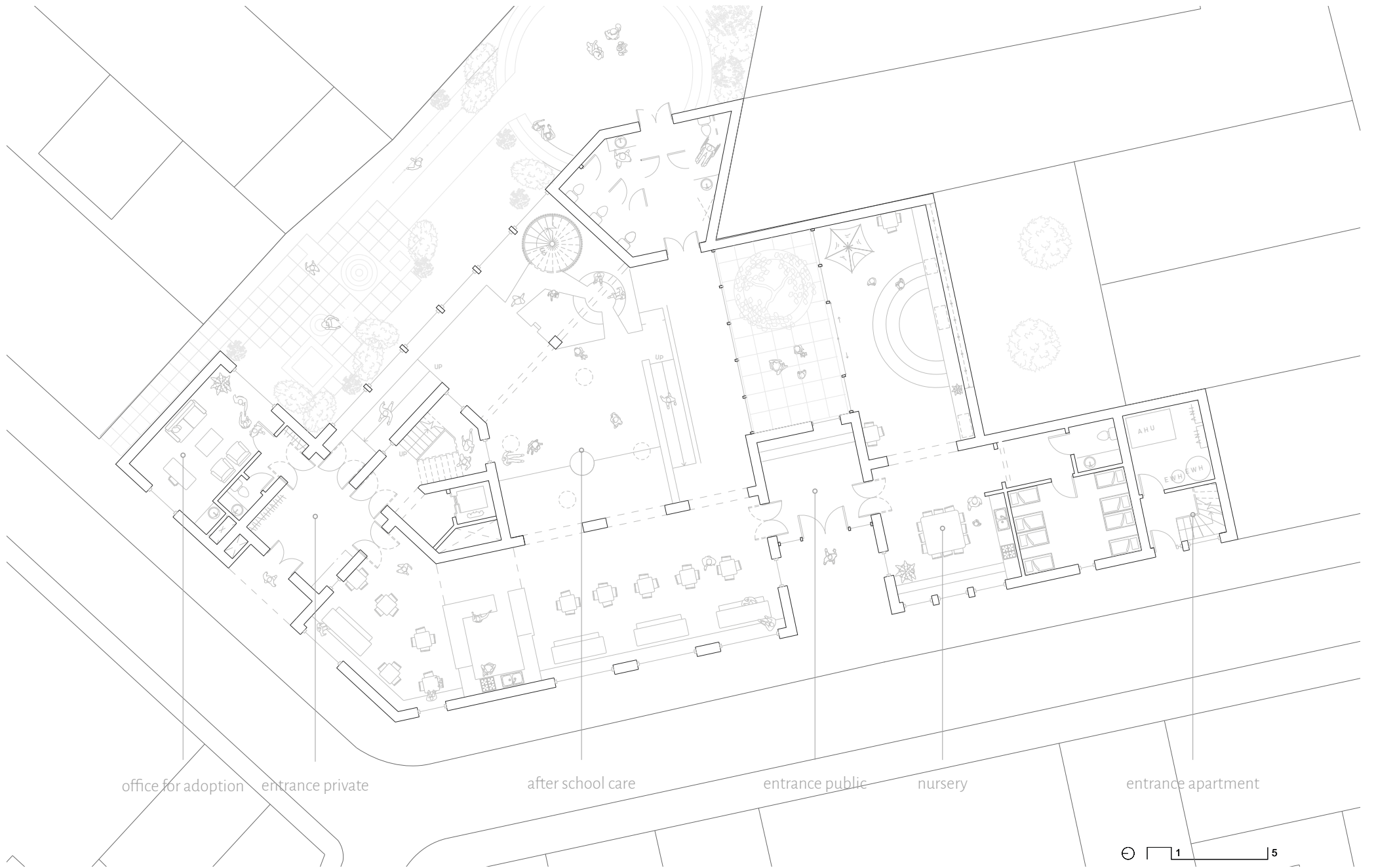

office for adoption entrance private

after school care

entrance public

nursery

entrance apartment









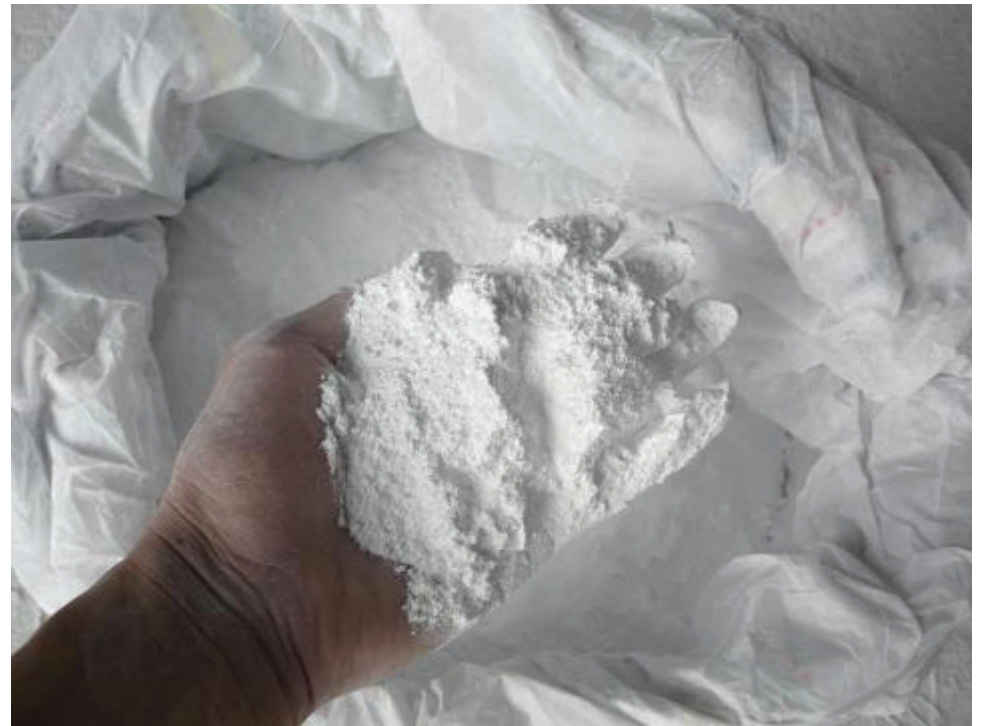





Eternit solar roof slates  
~ 100 m<sup>2</sup> South = 15.000 kWh/year  
~ 140 m<sup>2</sup> East-West = 12.500 kWh/year

Roof insulated with hennepp panels  
300 mm, Rc 7,5 m<sup>2</sup>K/W

Accoya stained windowframes,  
lifespan ~ 50 years.

Linoleum flooring  
Dry floor heating system  
Acoustic wood panels in between  
floor beams

Viroc woodfiber cladding 16 mm,  
mounted on aluminium profiles

Hempcrete cast-in-site exterior  
walls 400 mm, Rc 7,2 m<sup>2</sup>K/W with  
constructive timber frame

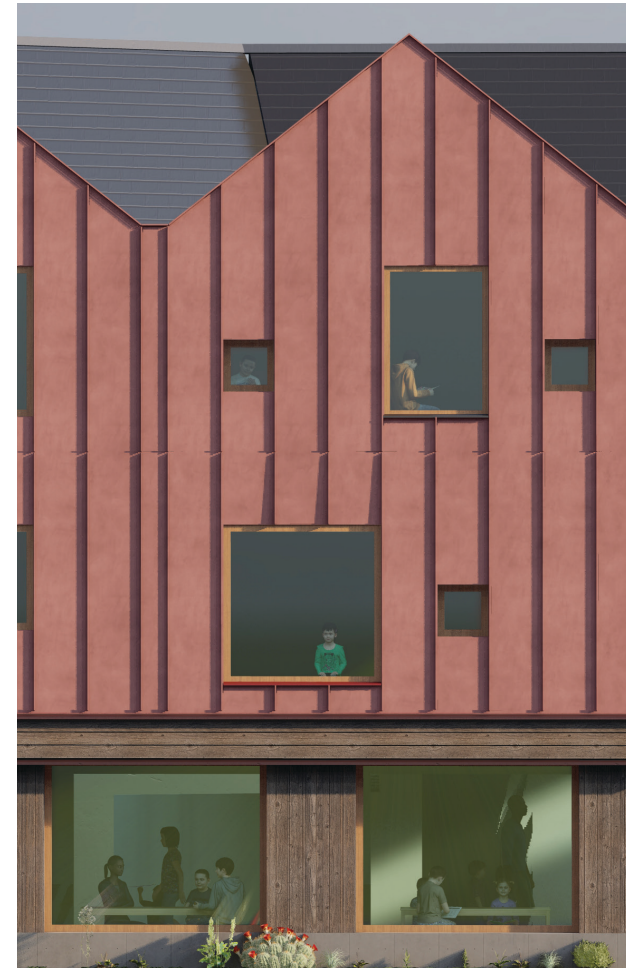
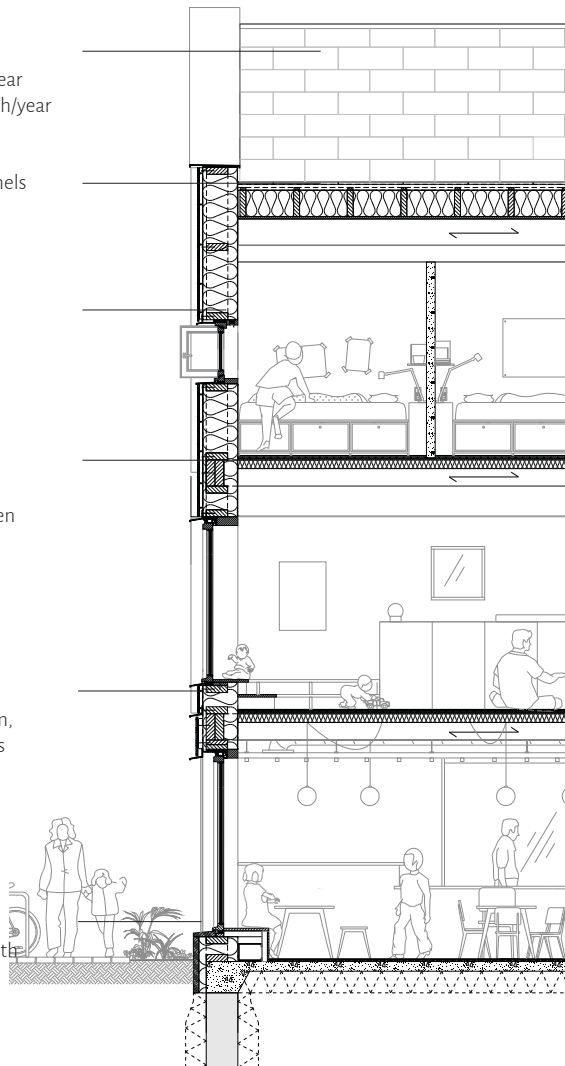













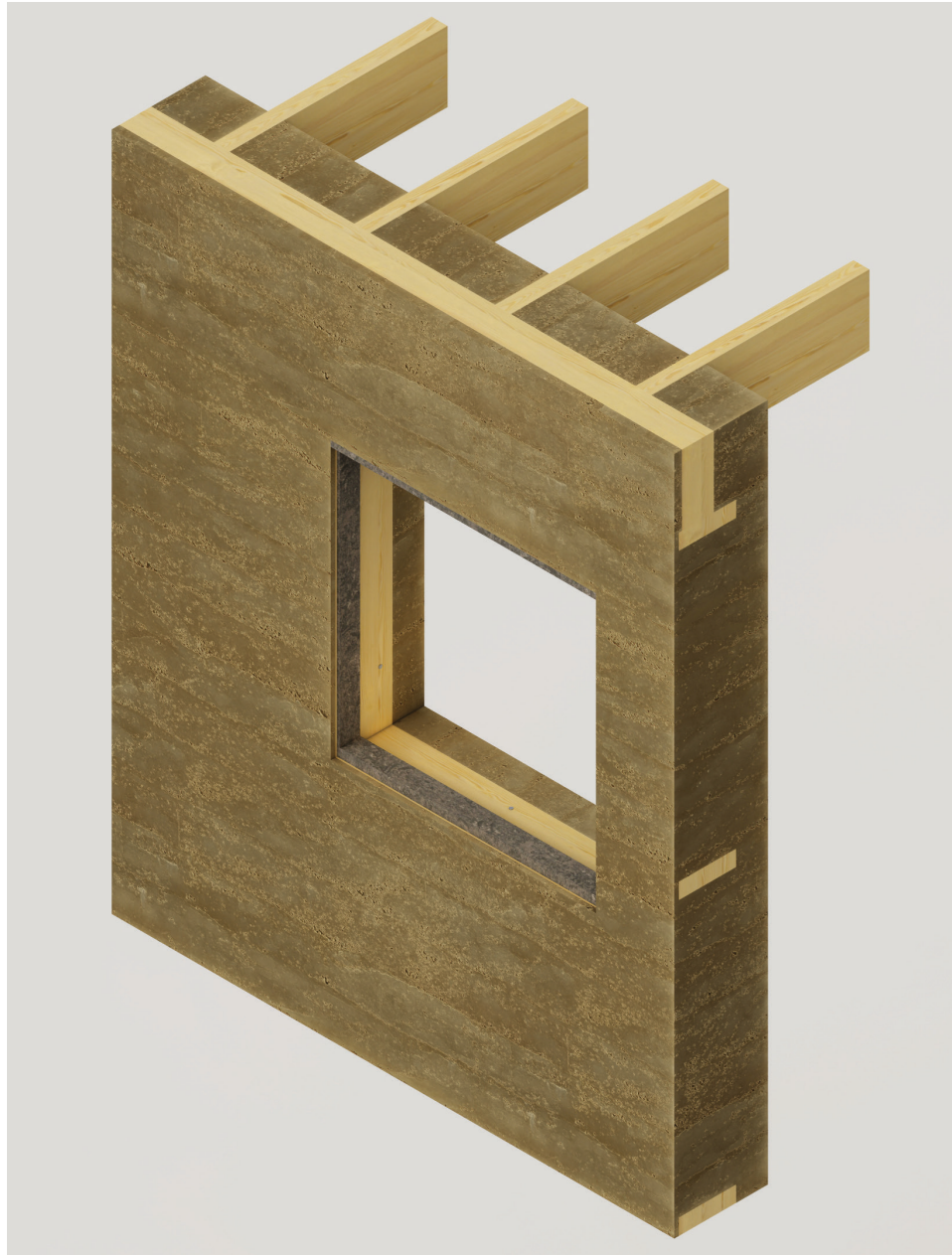





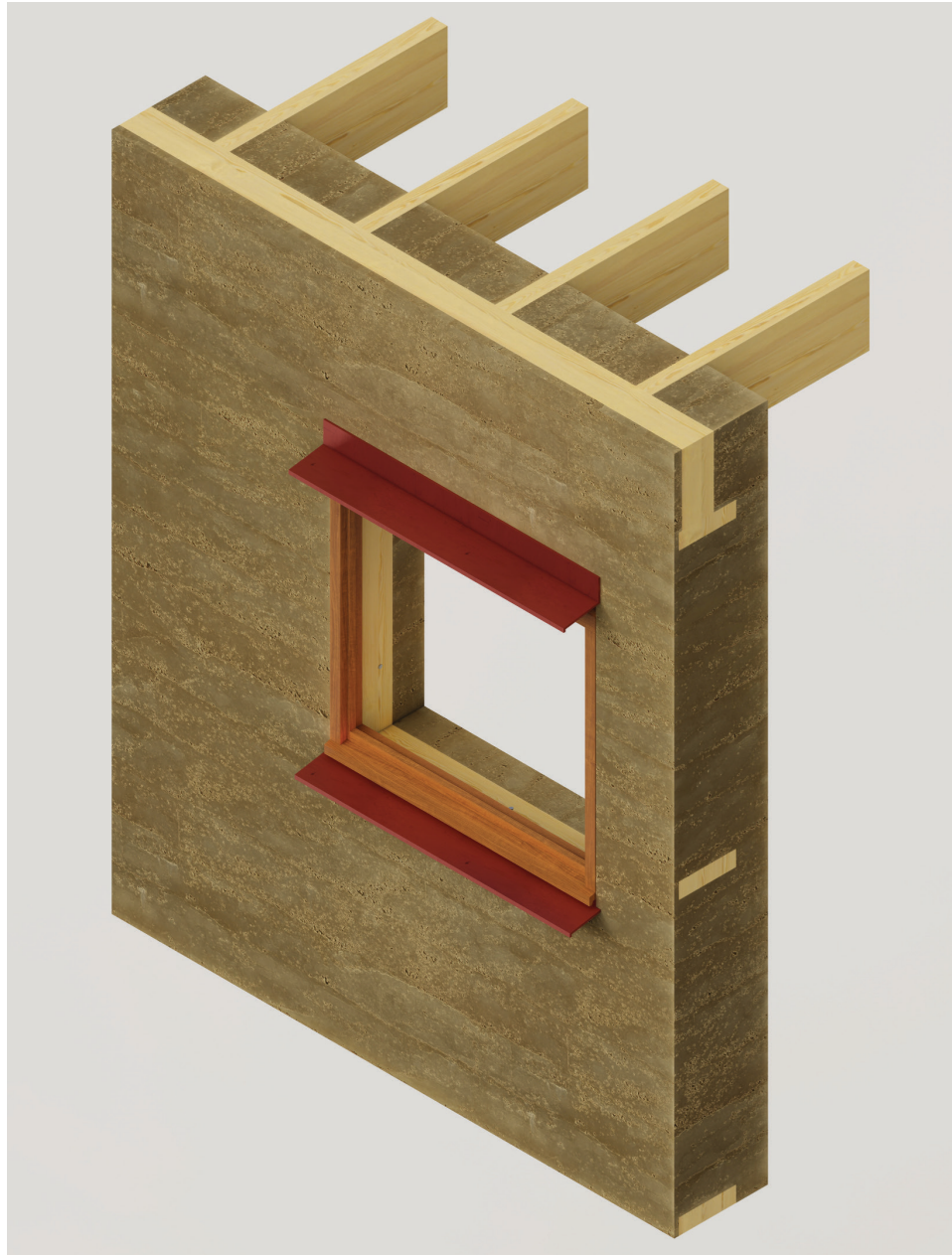

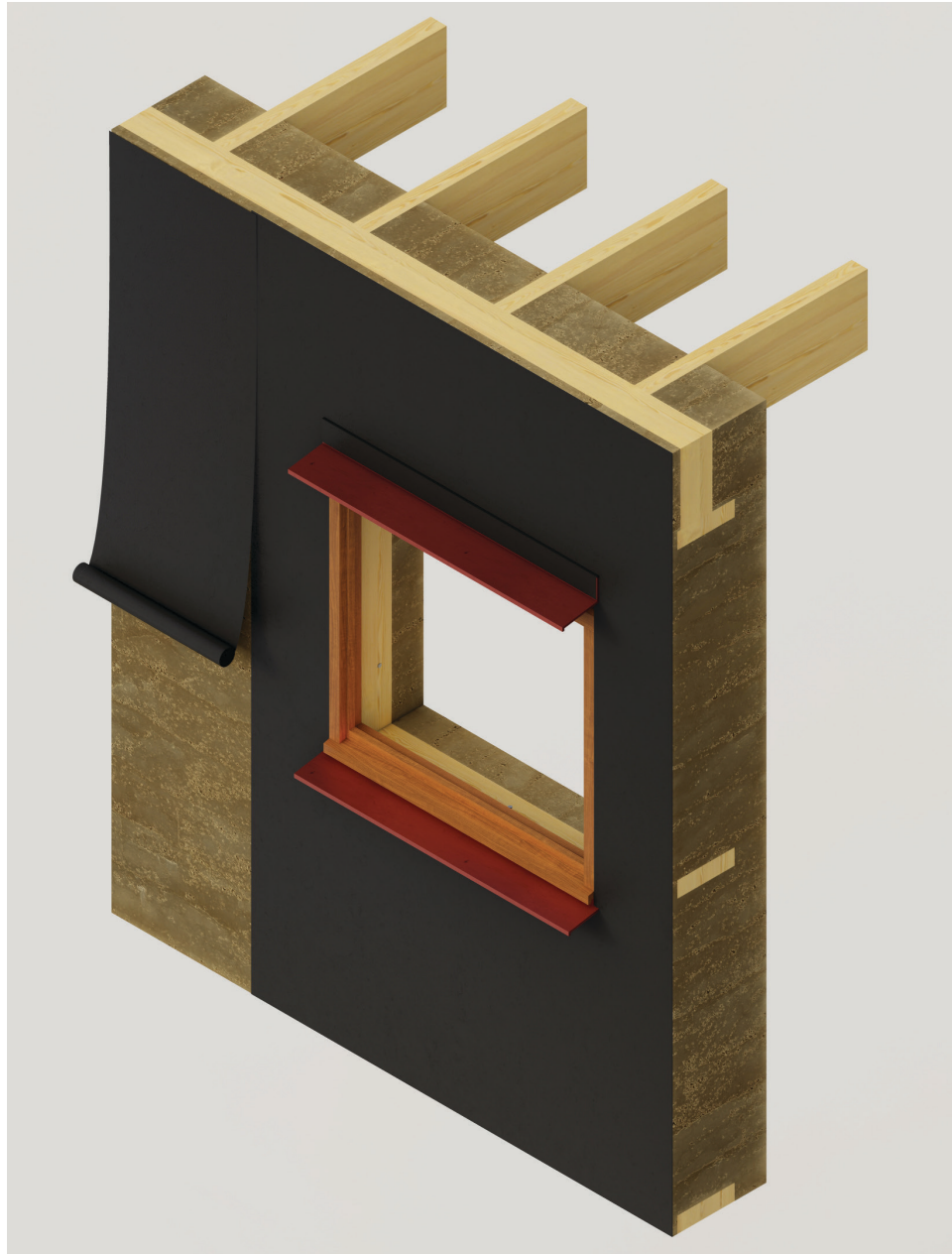

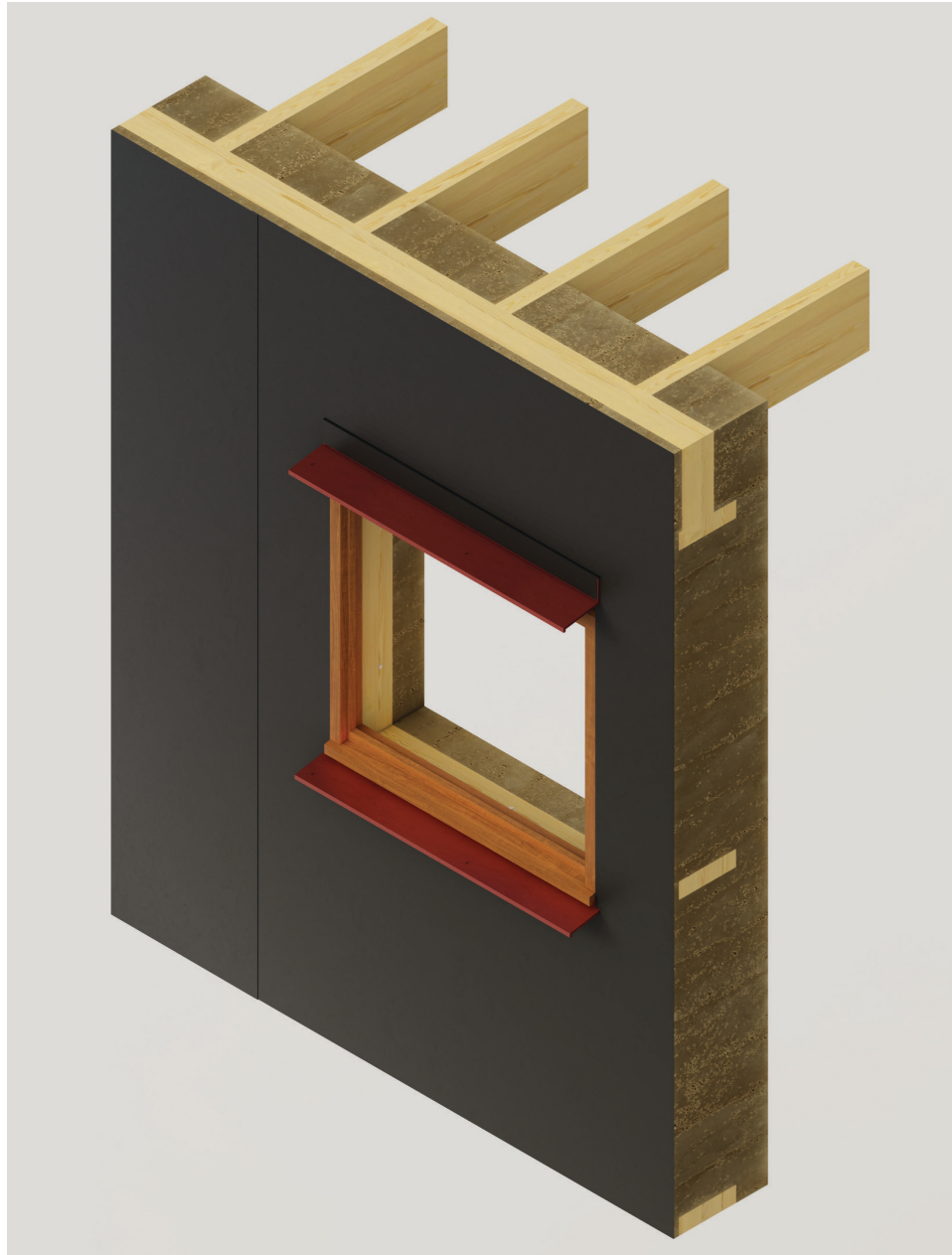

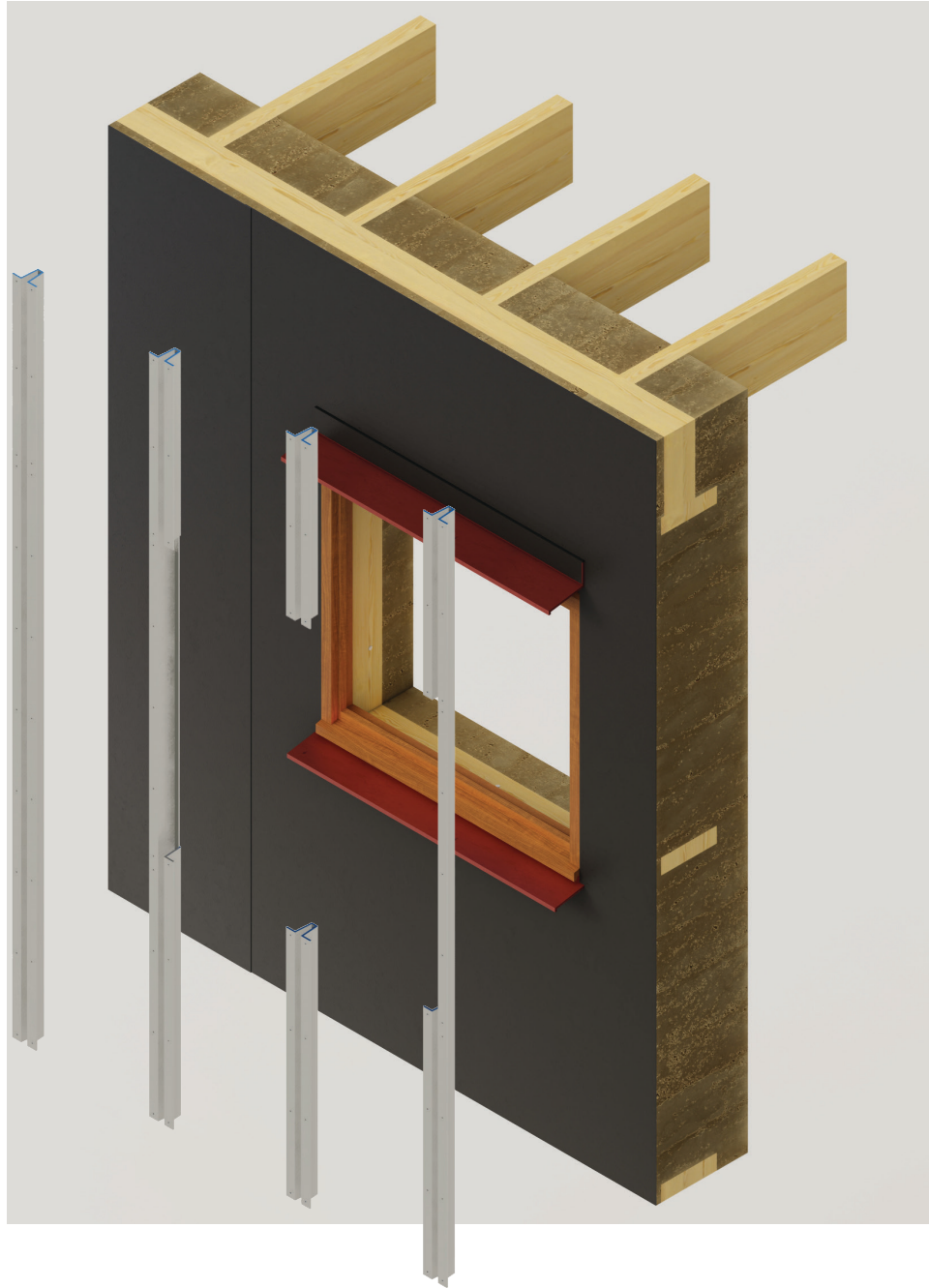

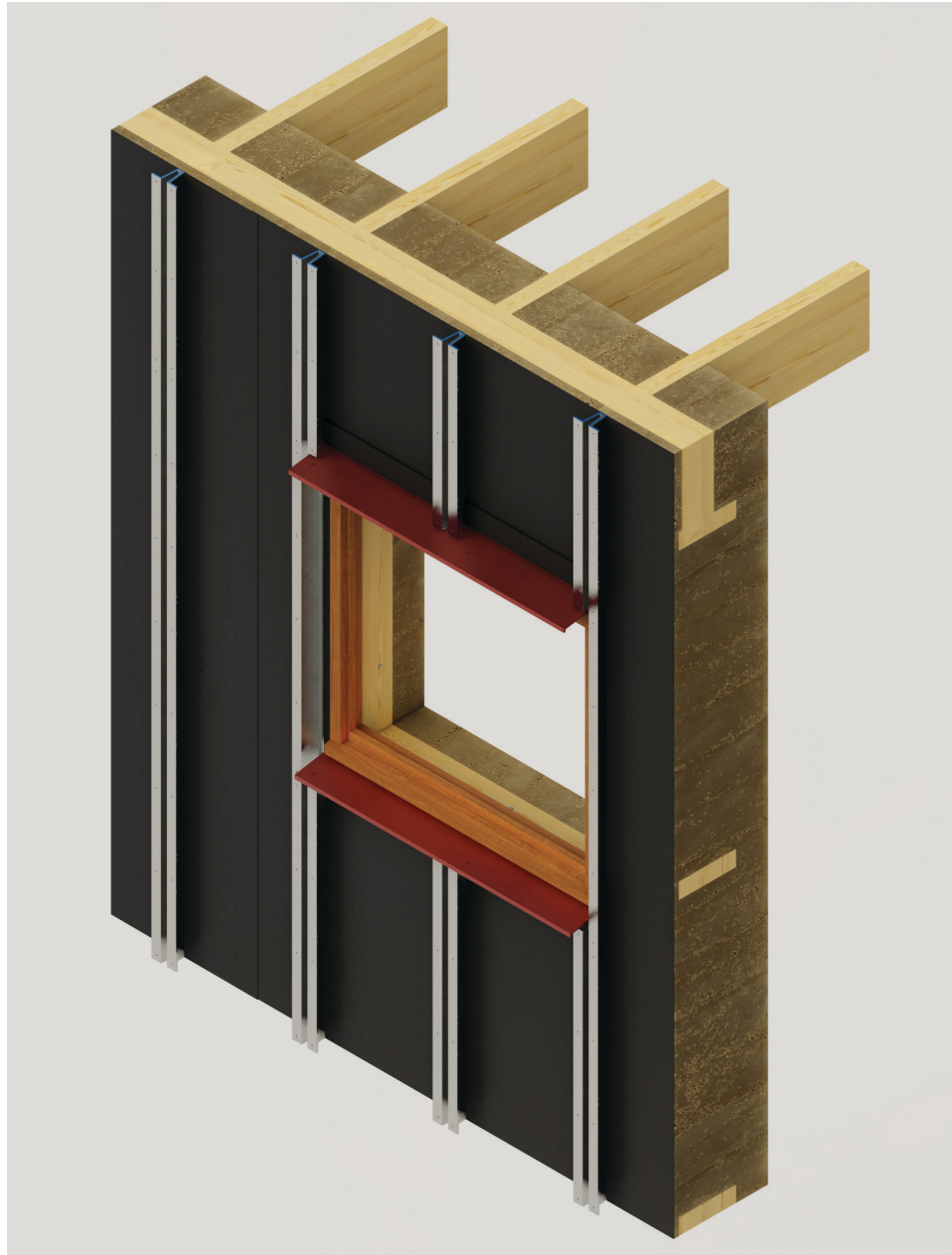

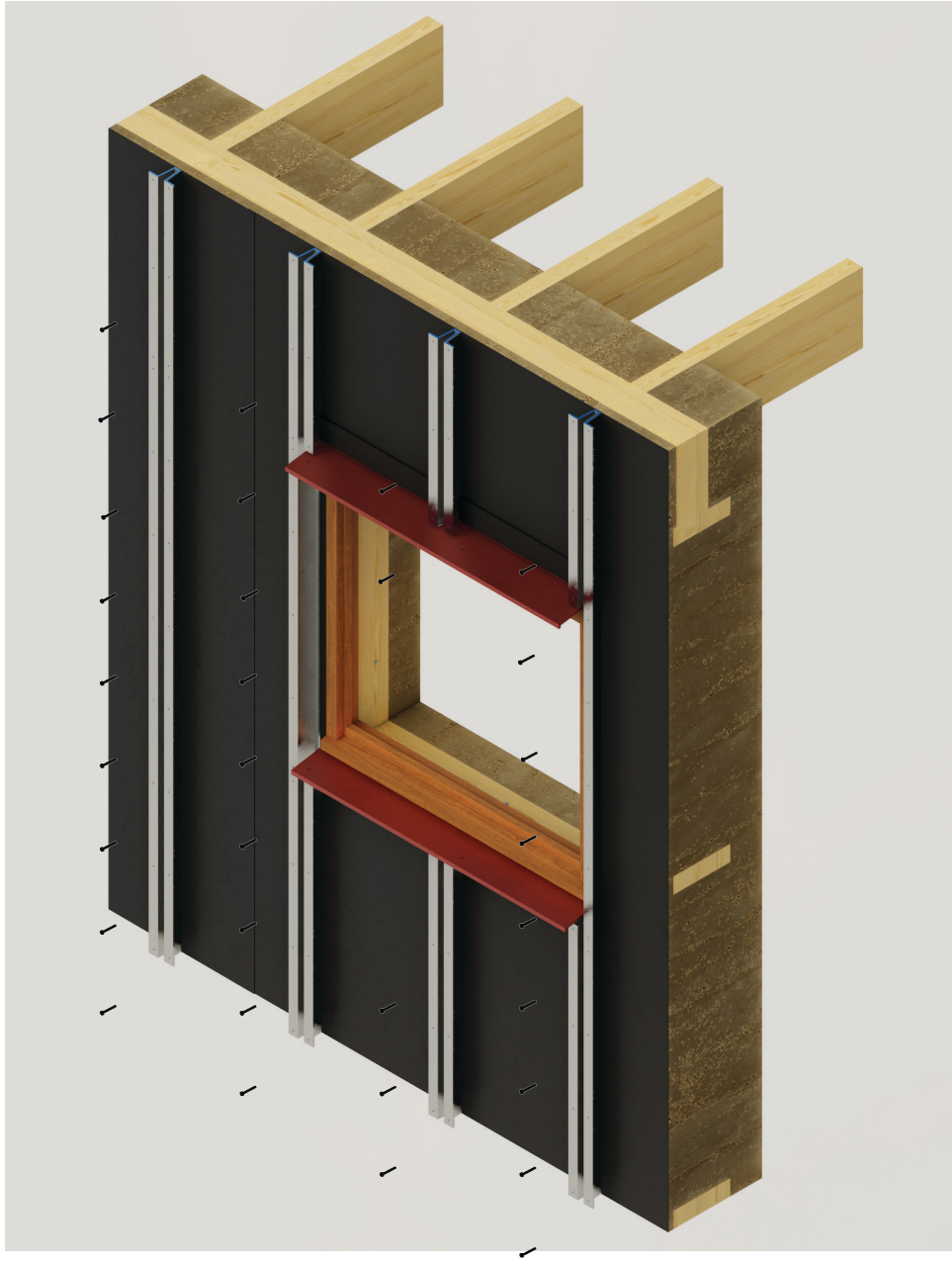

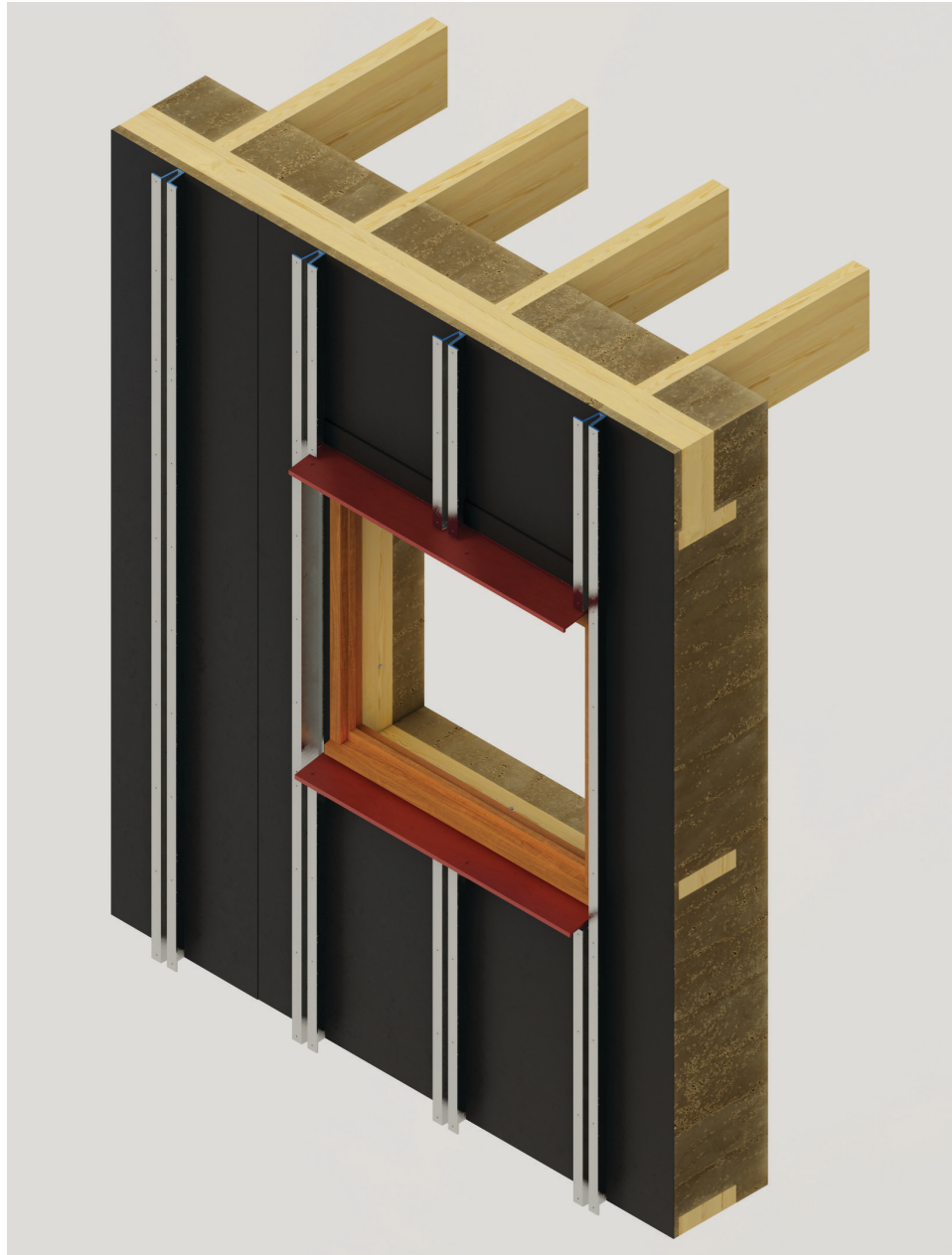



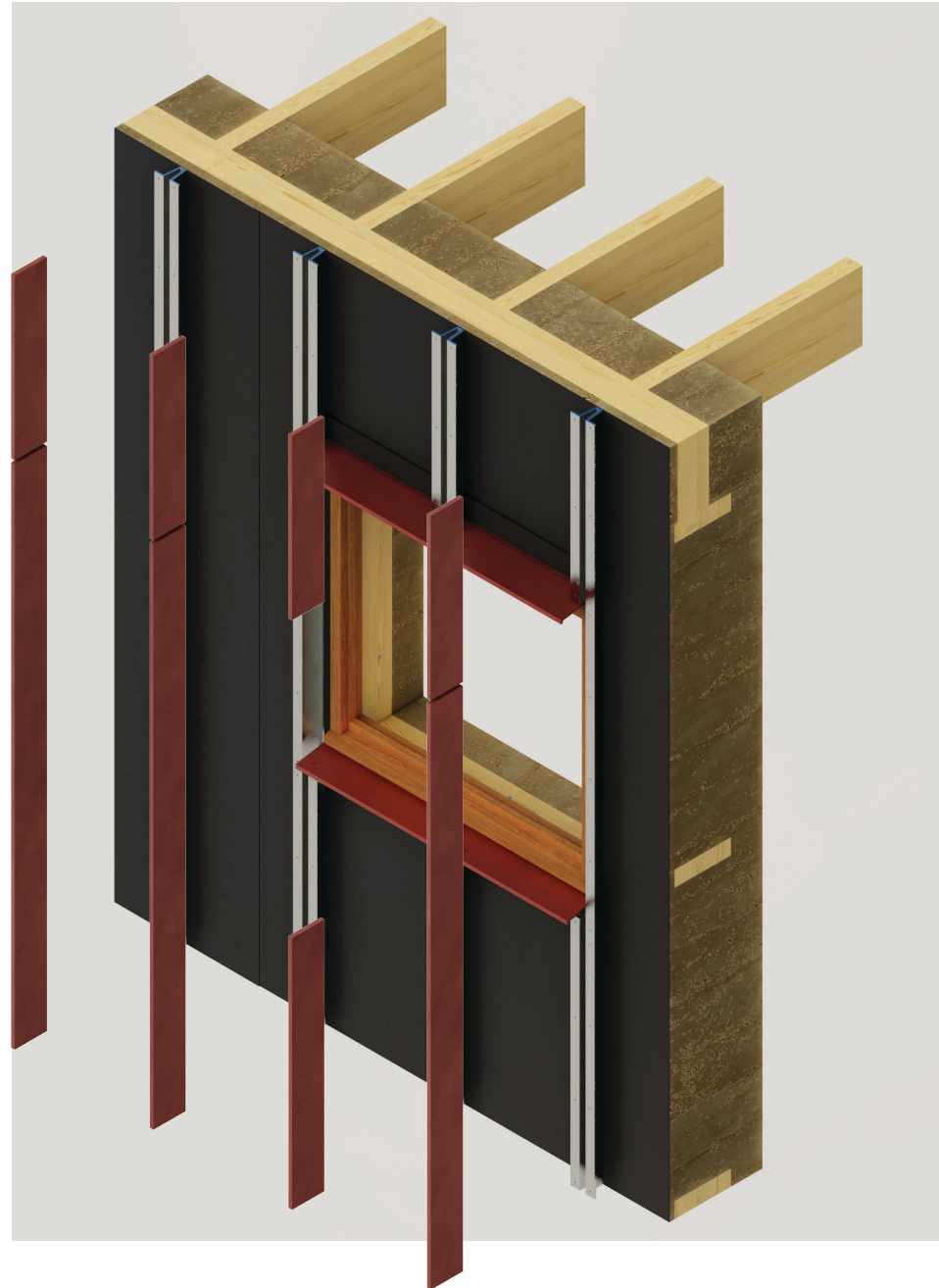



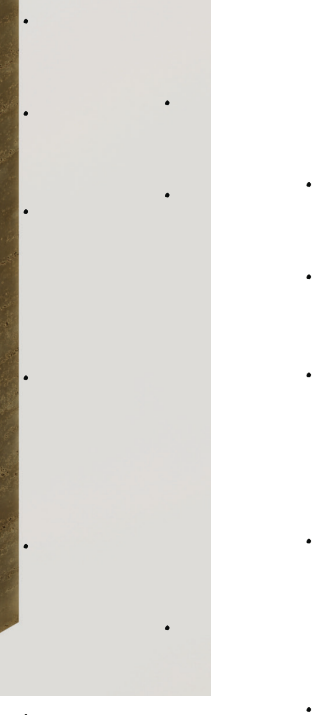
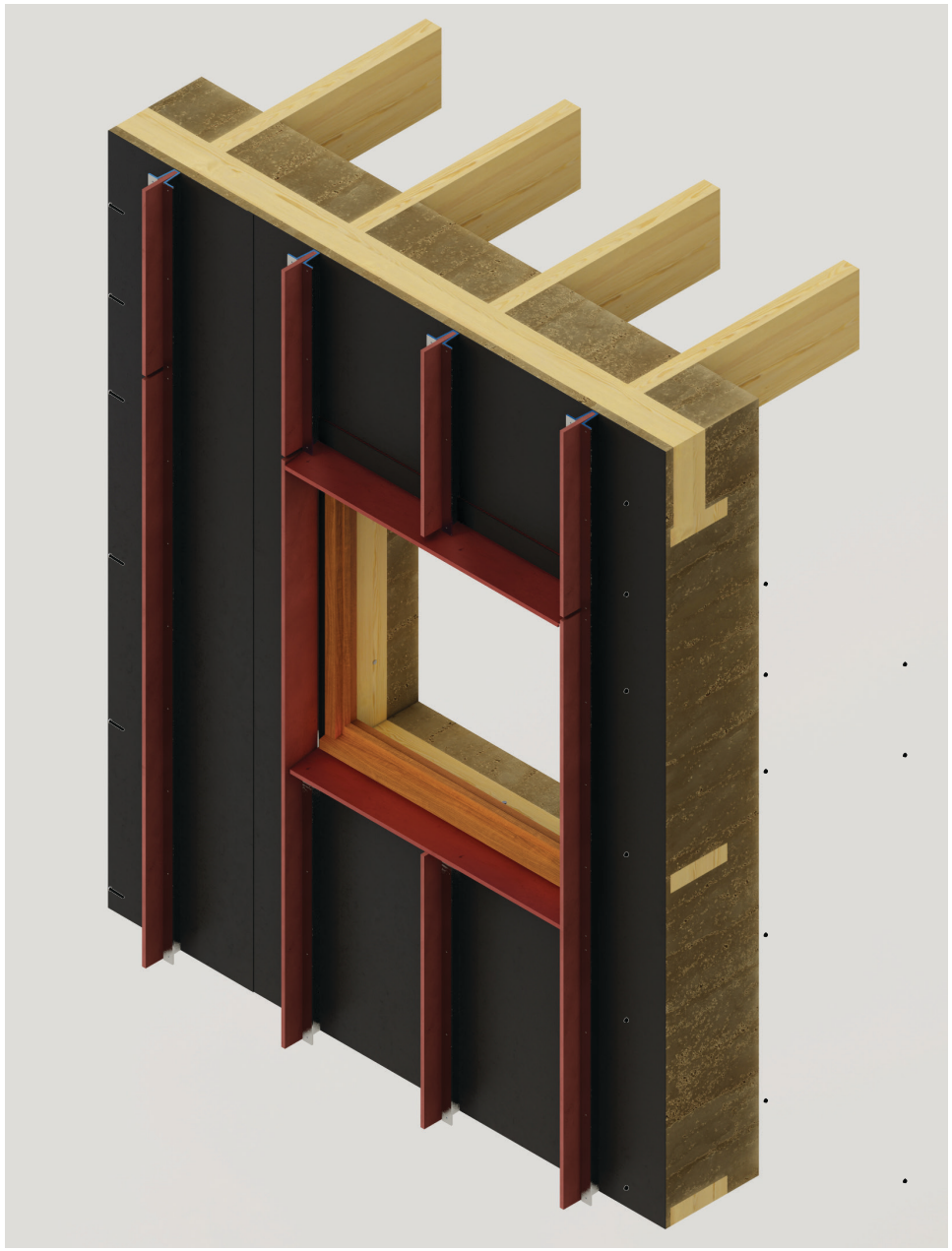



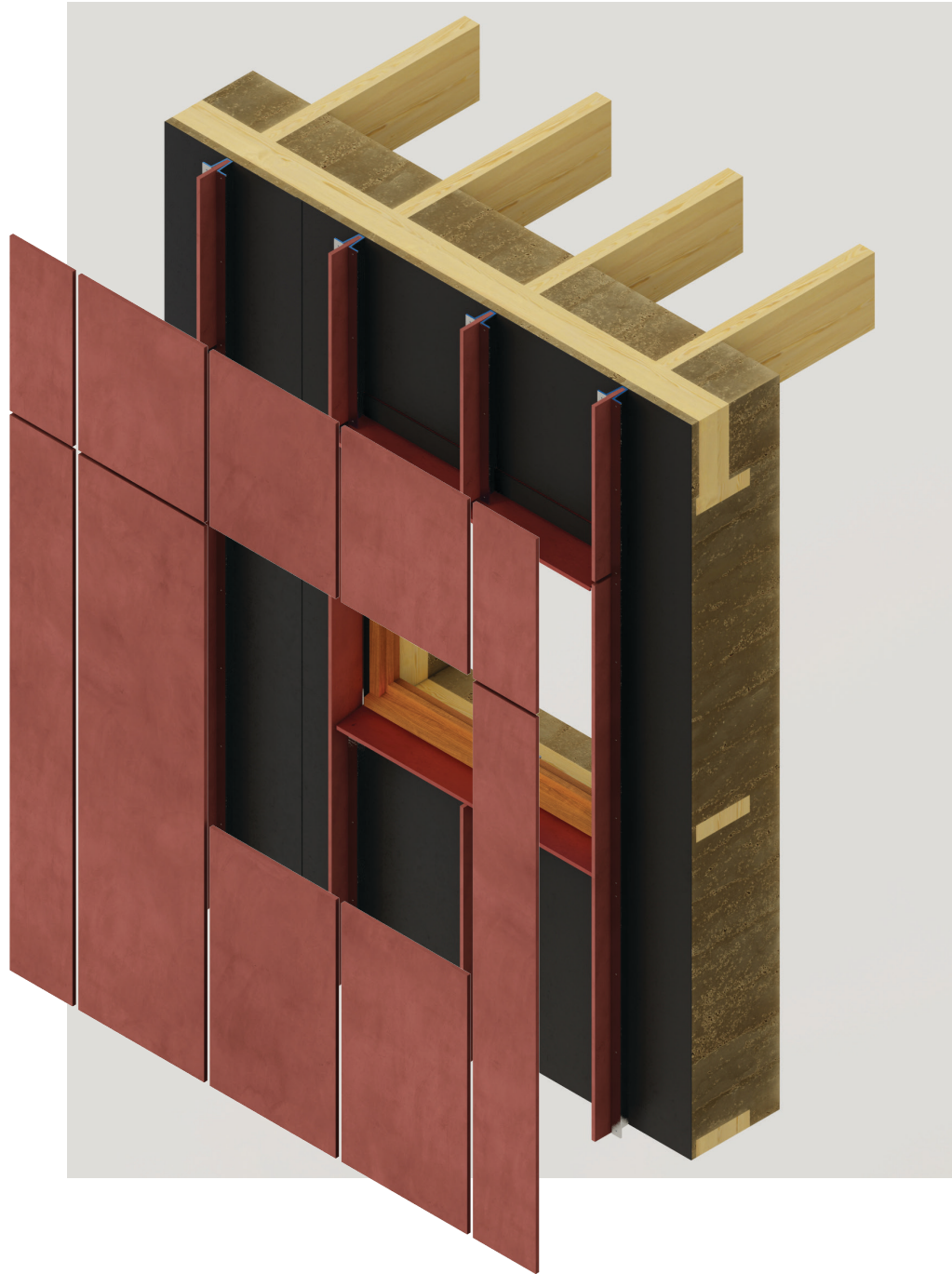

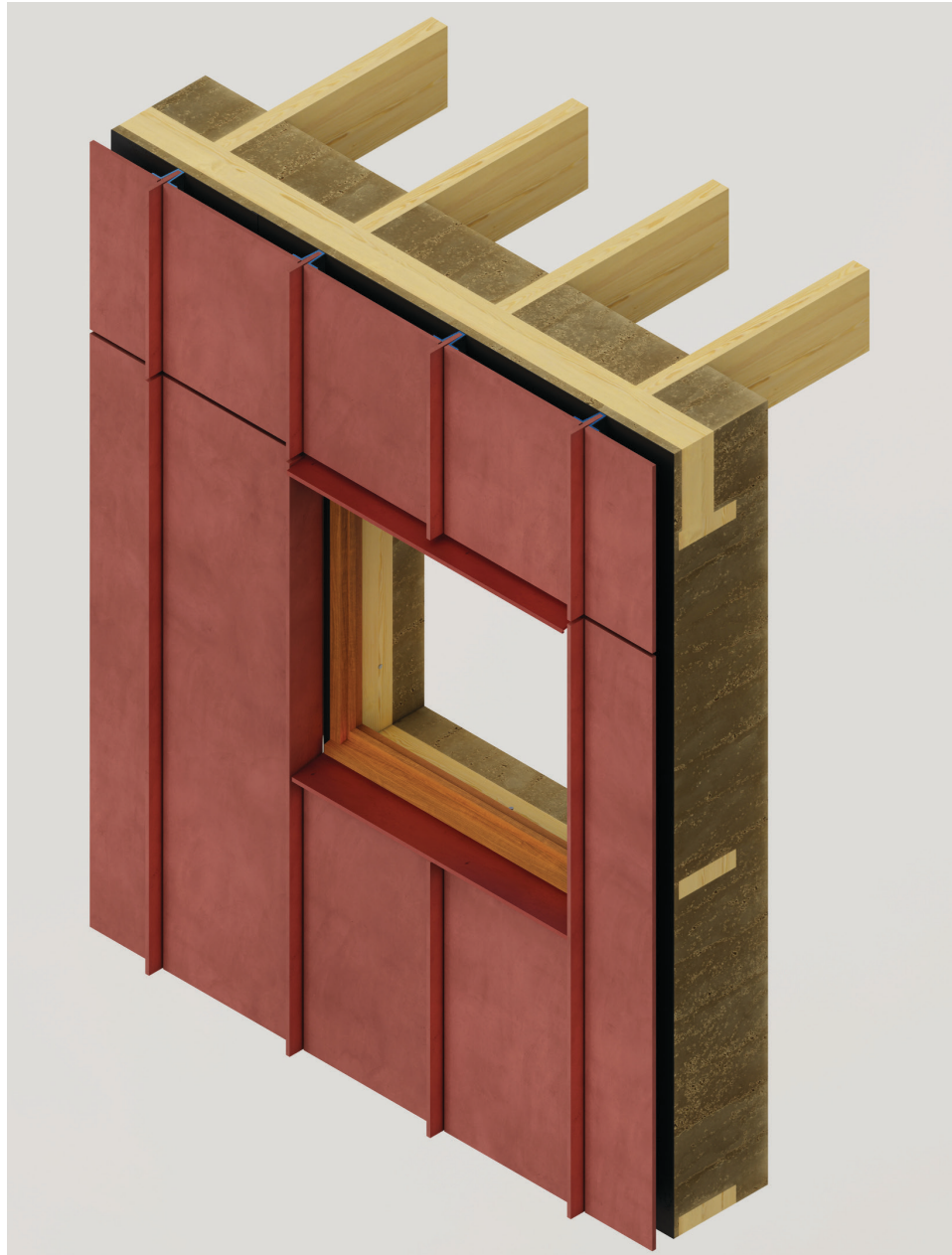

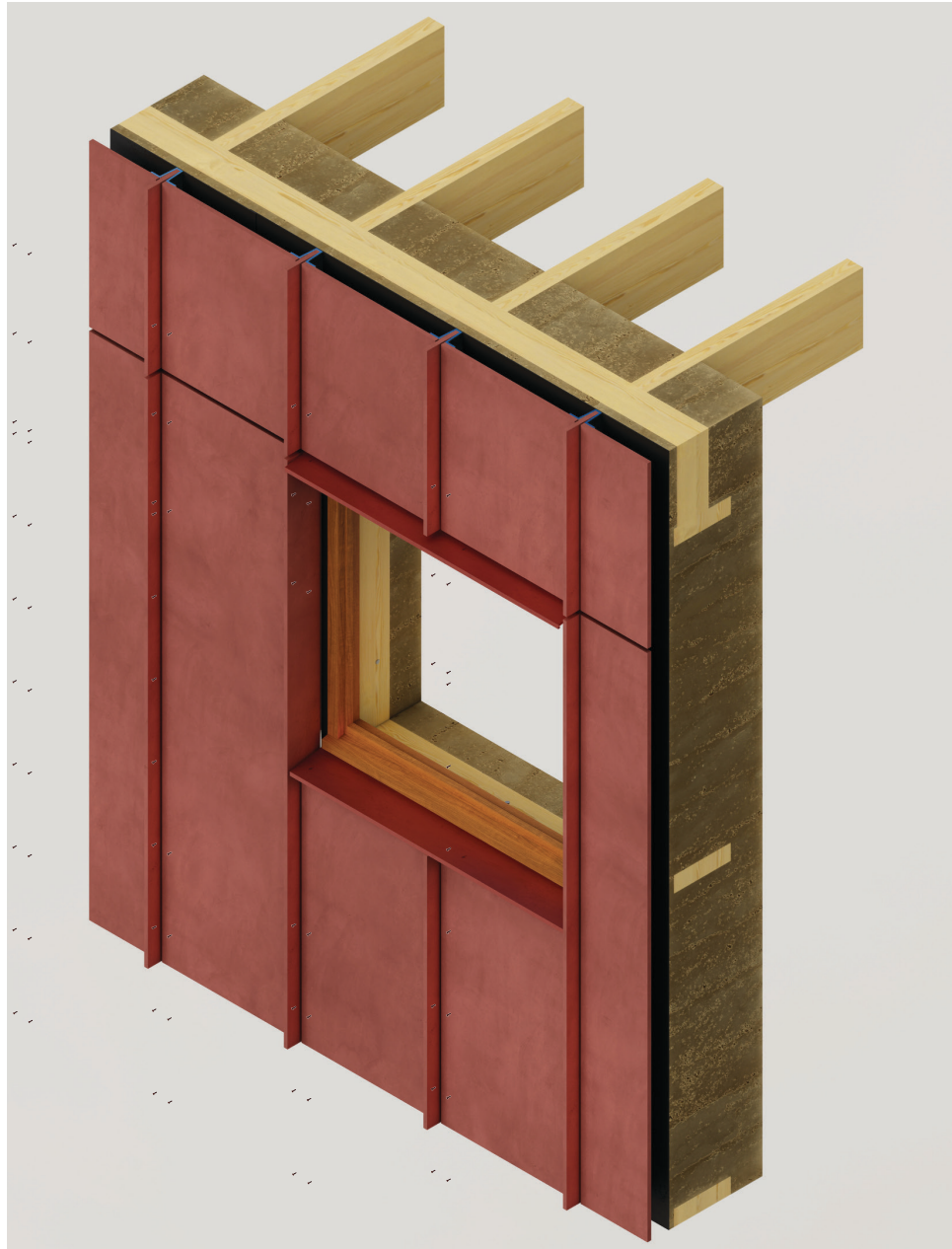

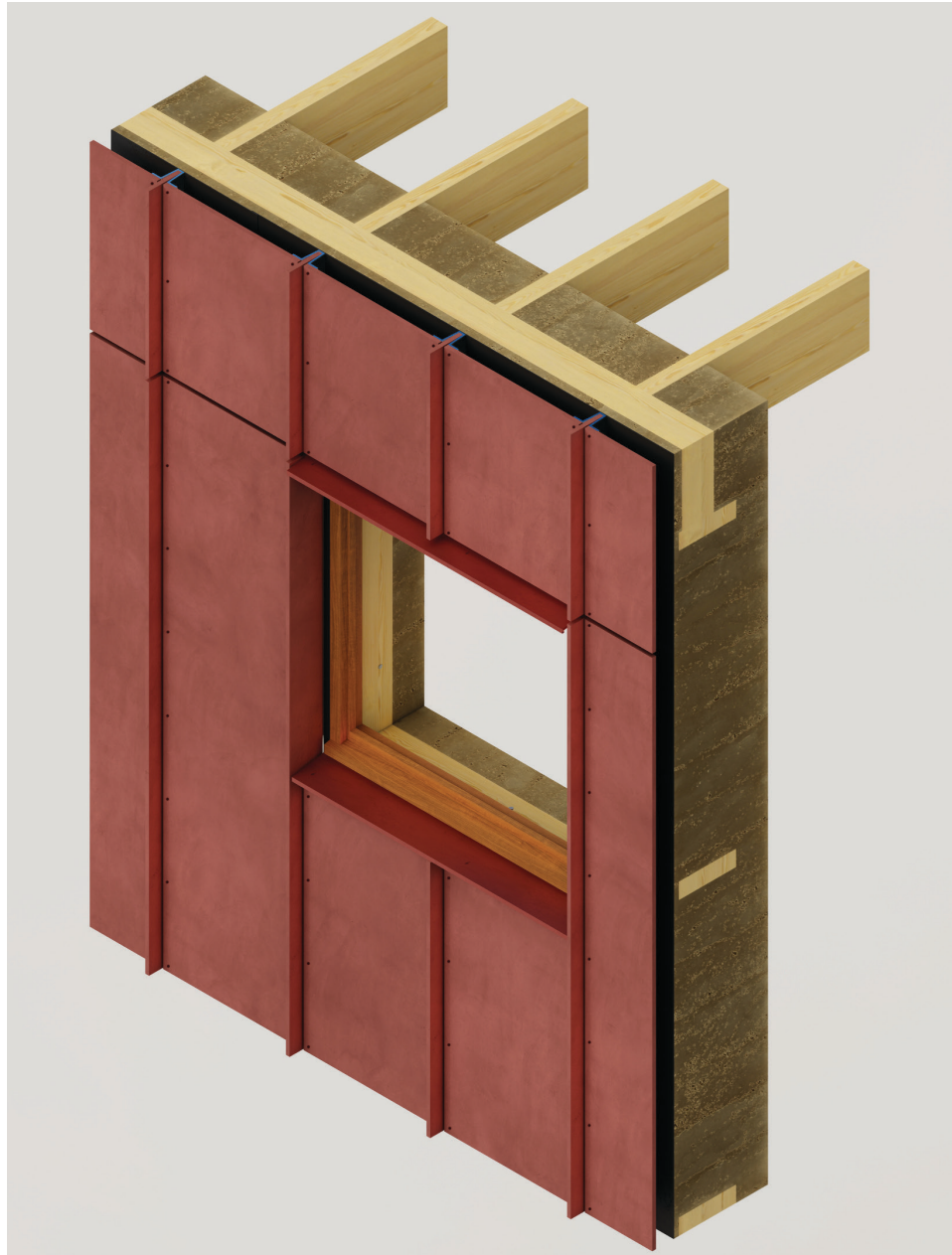



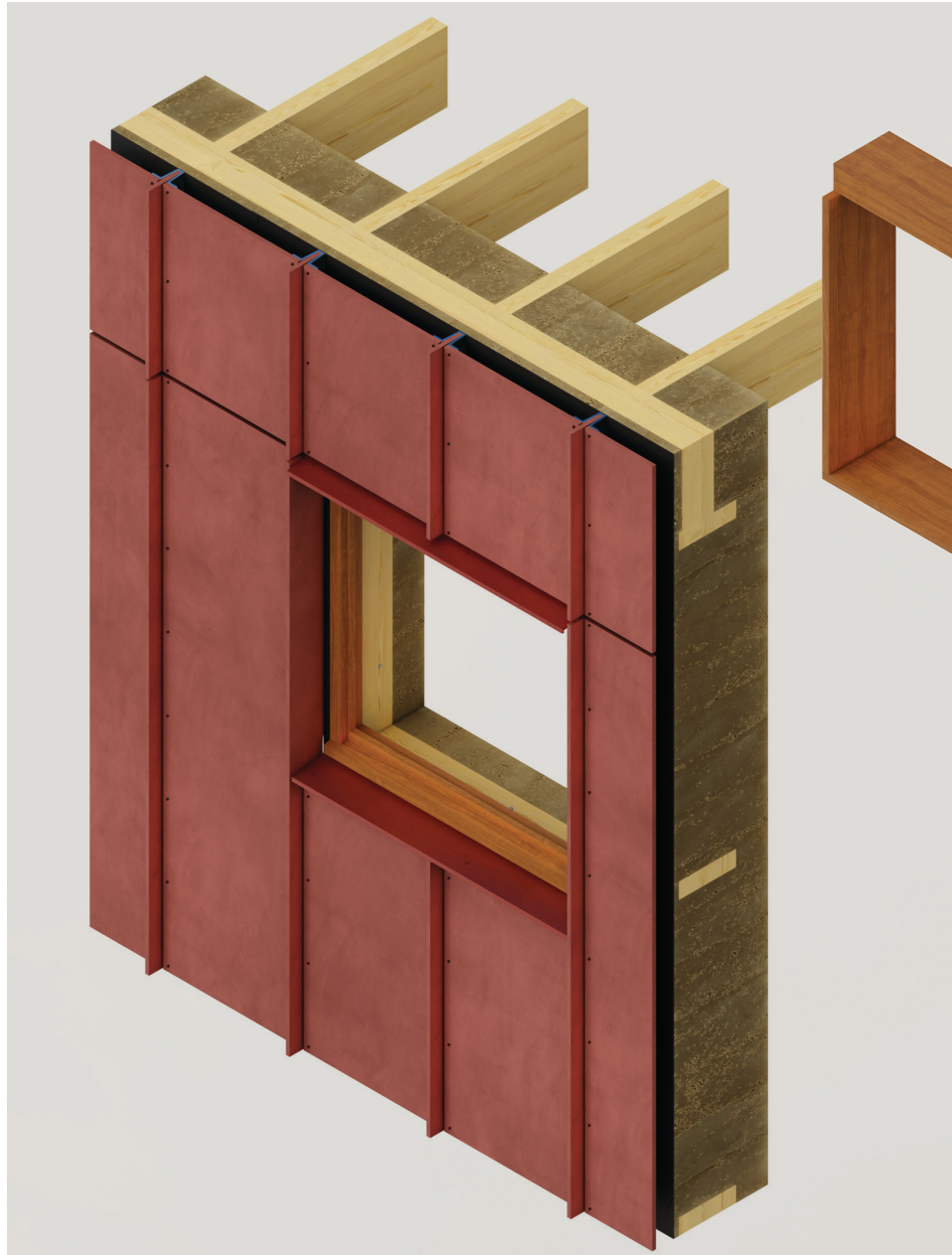



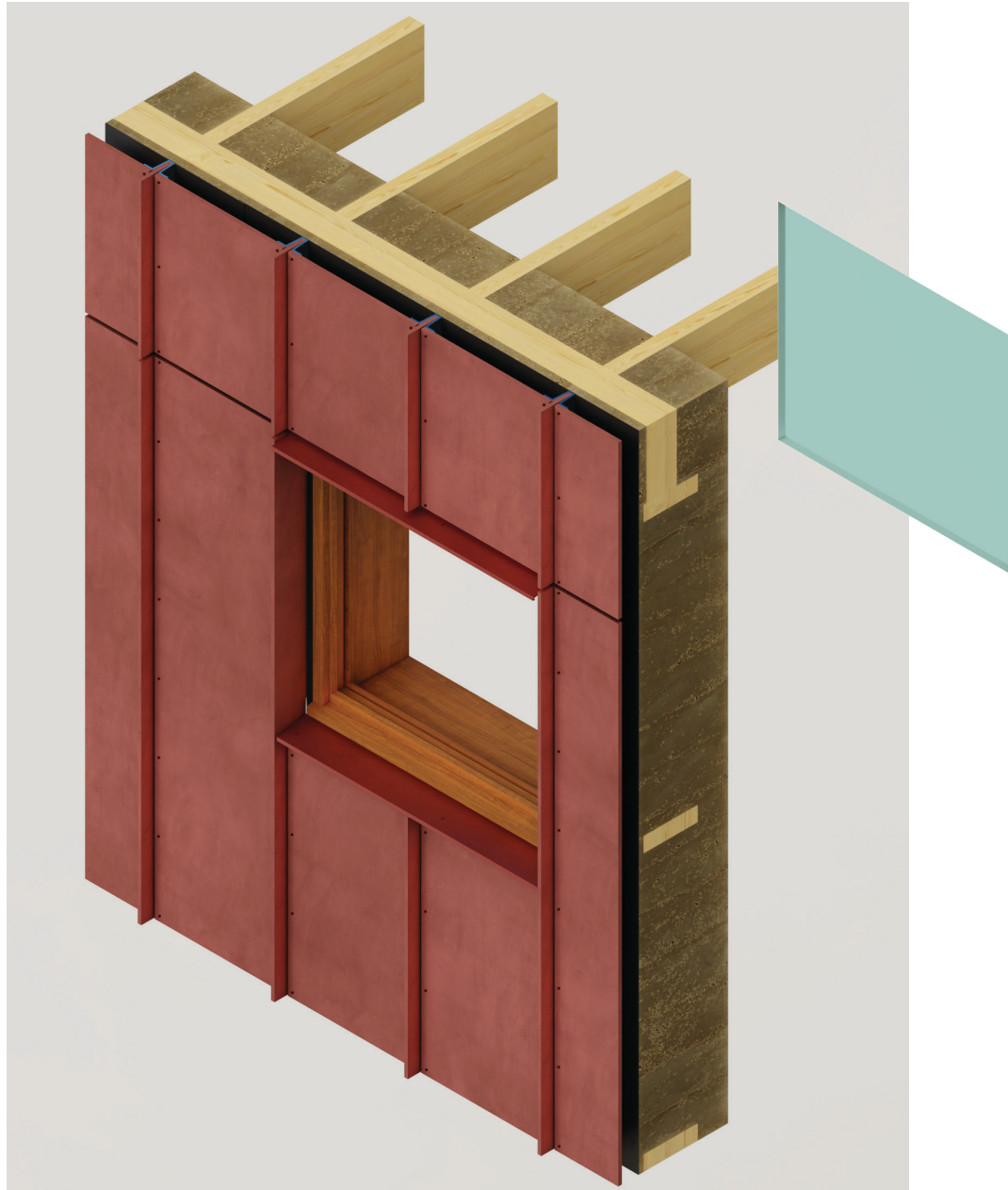

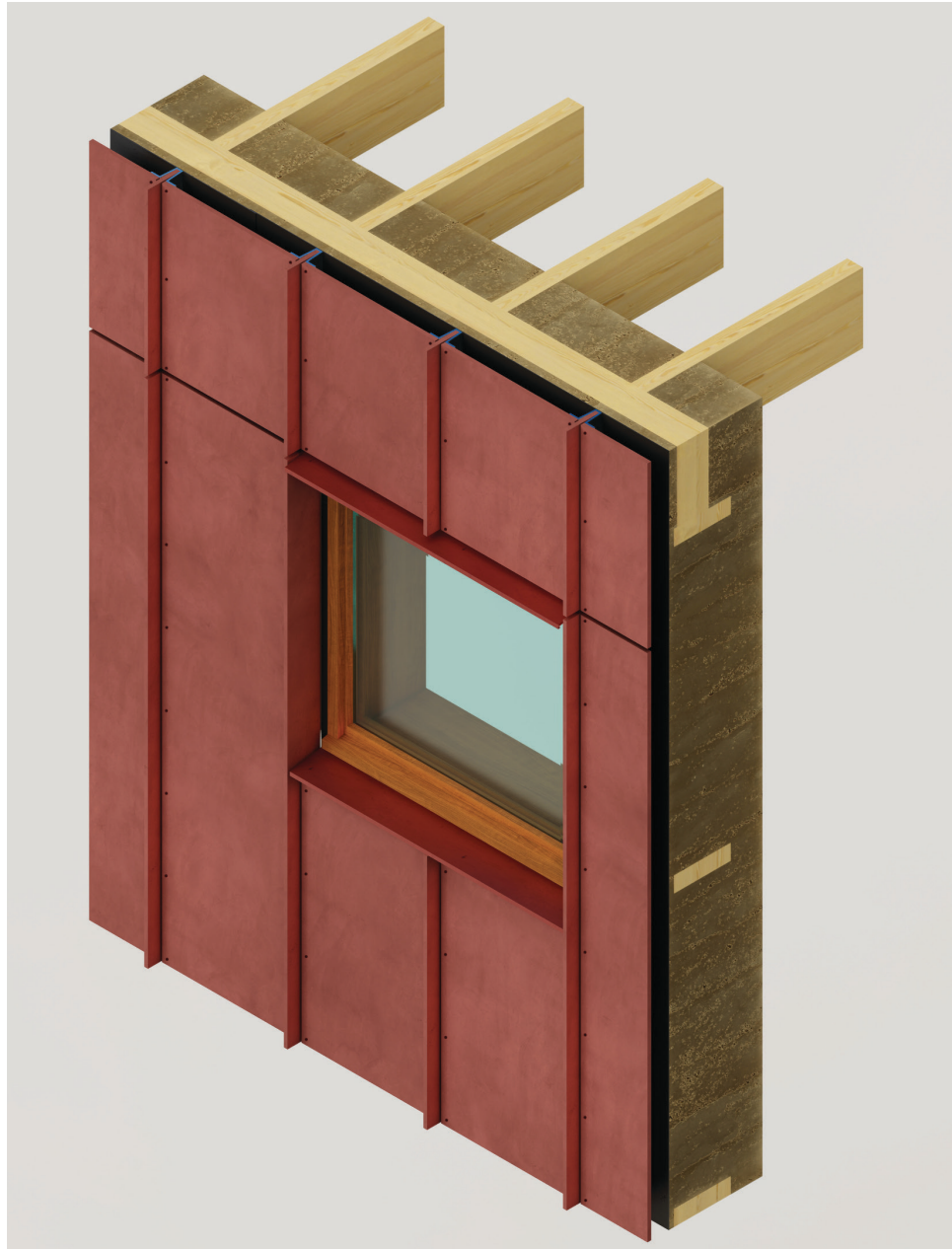

Timber frame 80 x 244 with casted-in-site hempcrete 400 mm,  $R_c = 7,2 \text{ m}^2\text{K/W}$

Water barrier

Aluminium profile screwed to timber frame, specific for openable windows

Viroc rib 16 x 140 mm, fit into aluminium U-profile and tightened with bolt and nut

Viroc panel 16 x 575 mm (max)

Corner aluminium profile

Typical aluminium profile

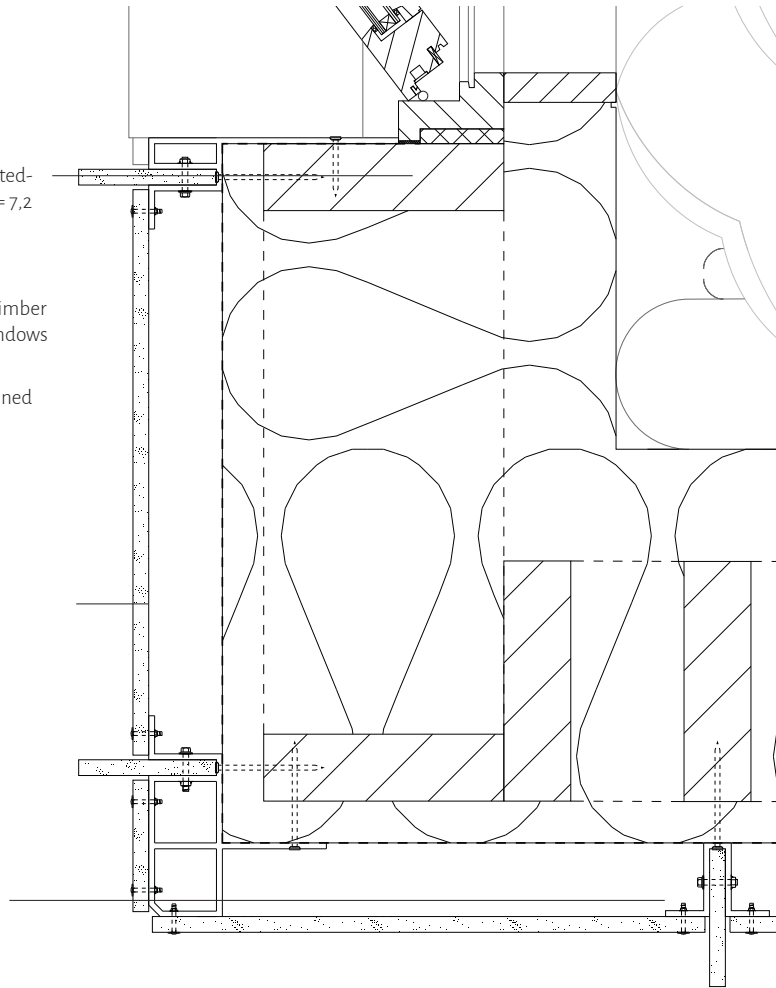





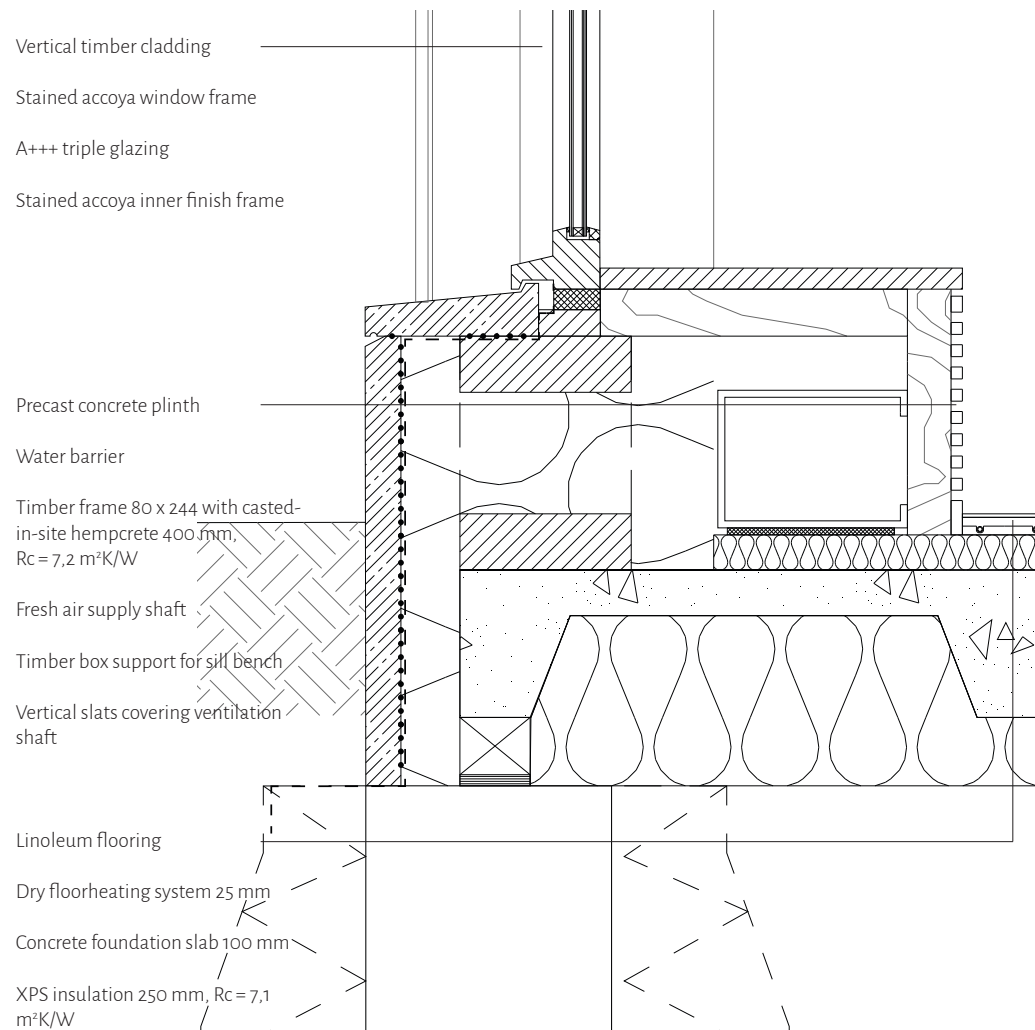



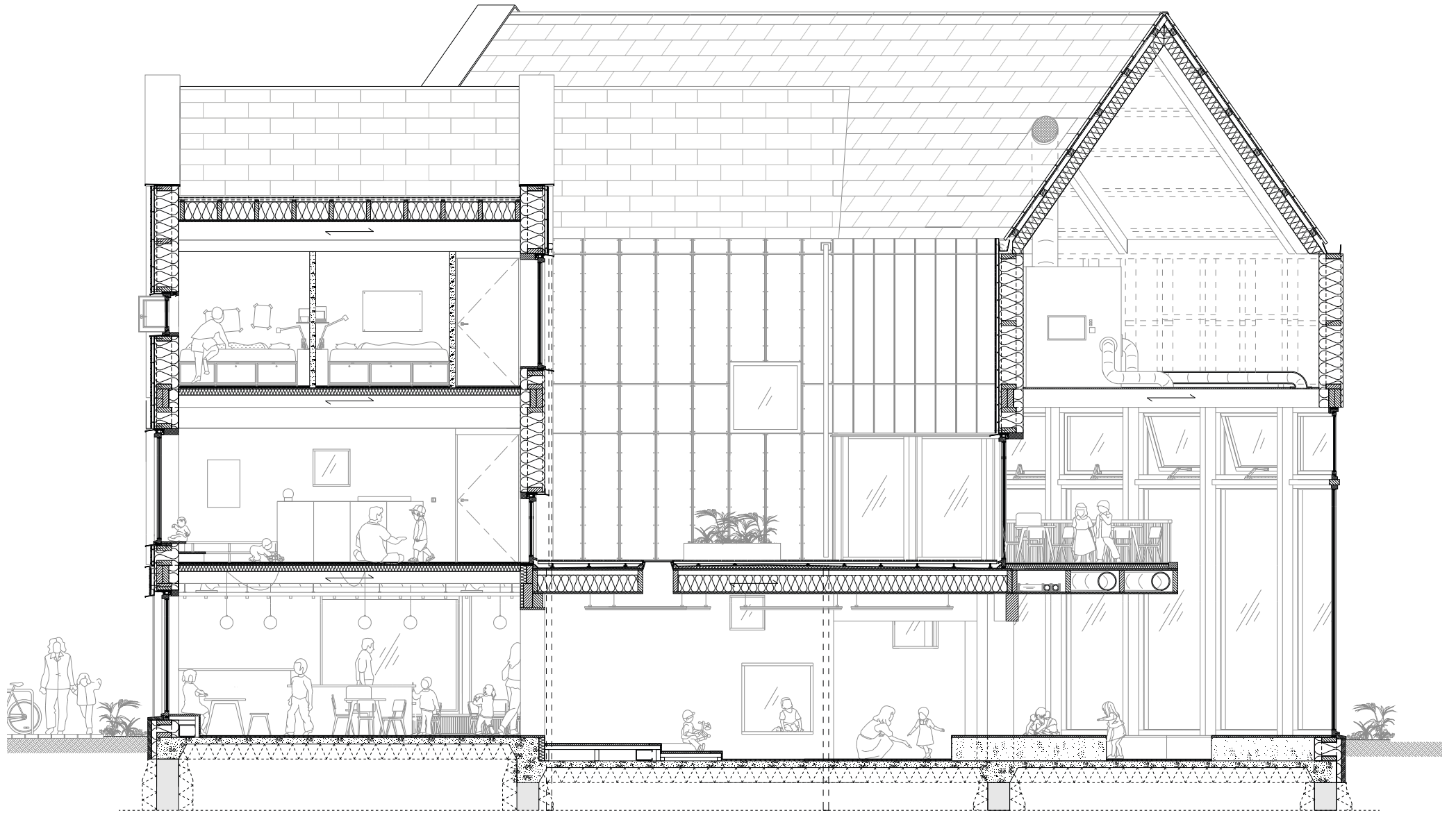

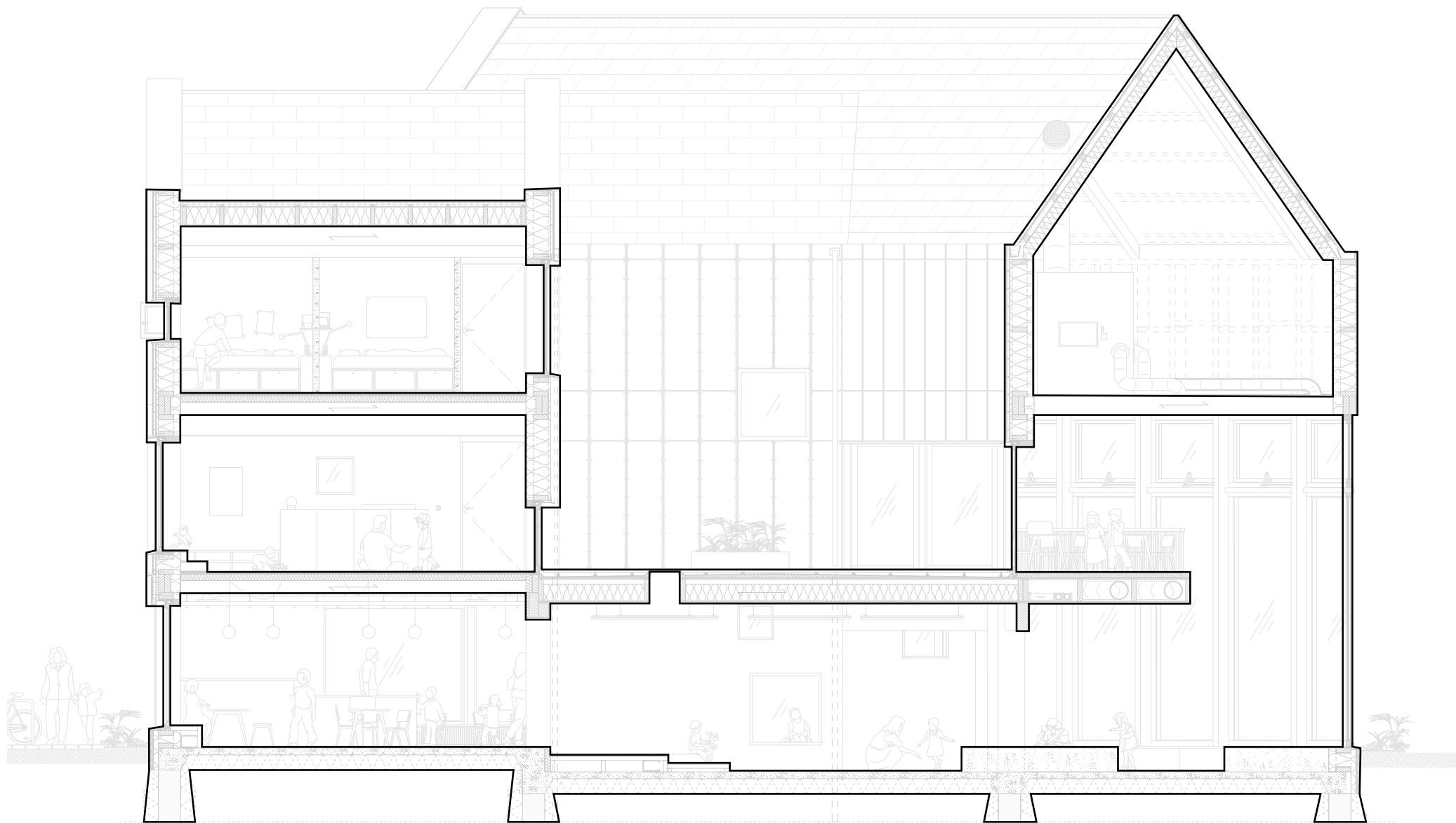

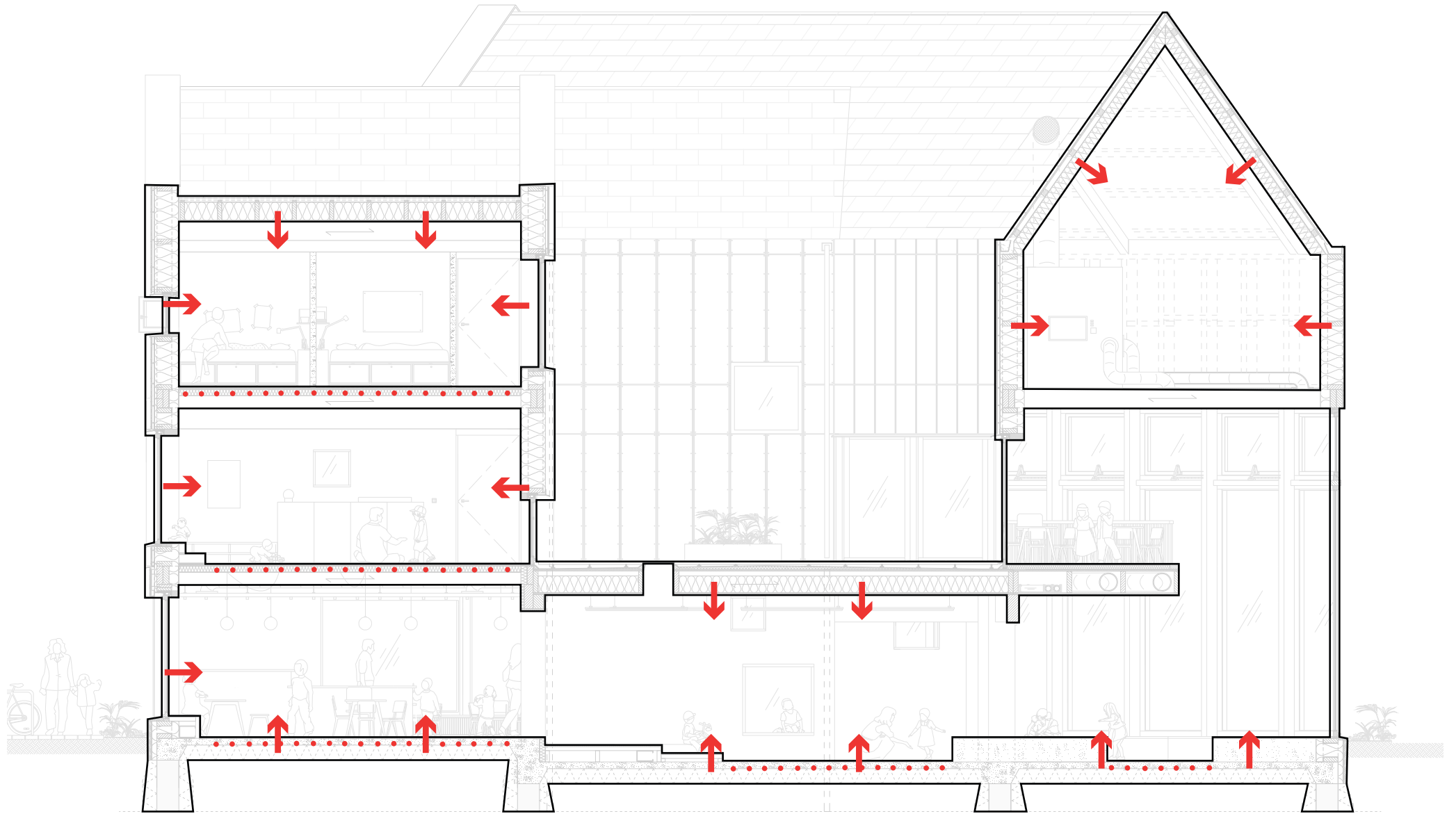

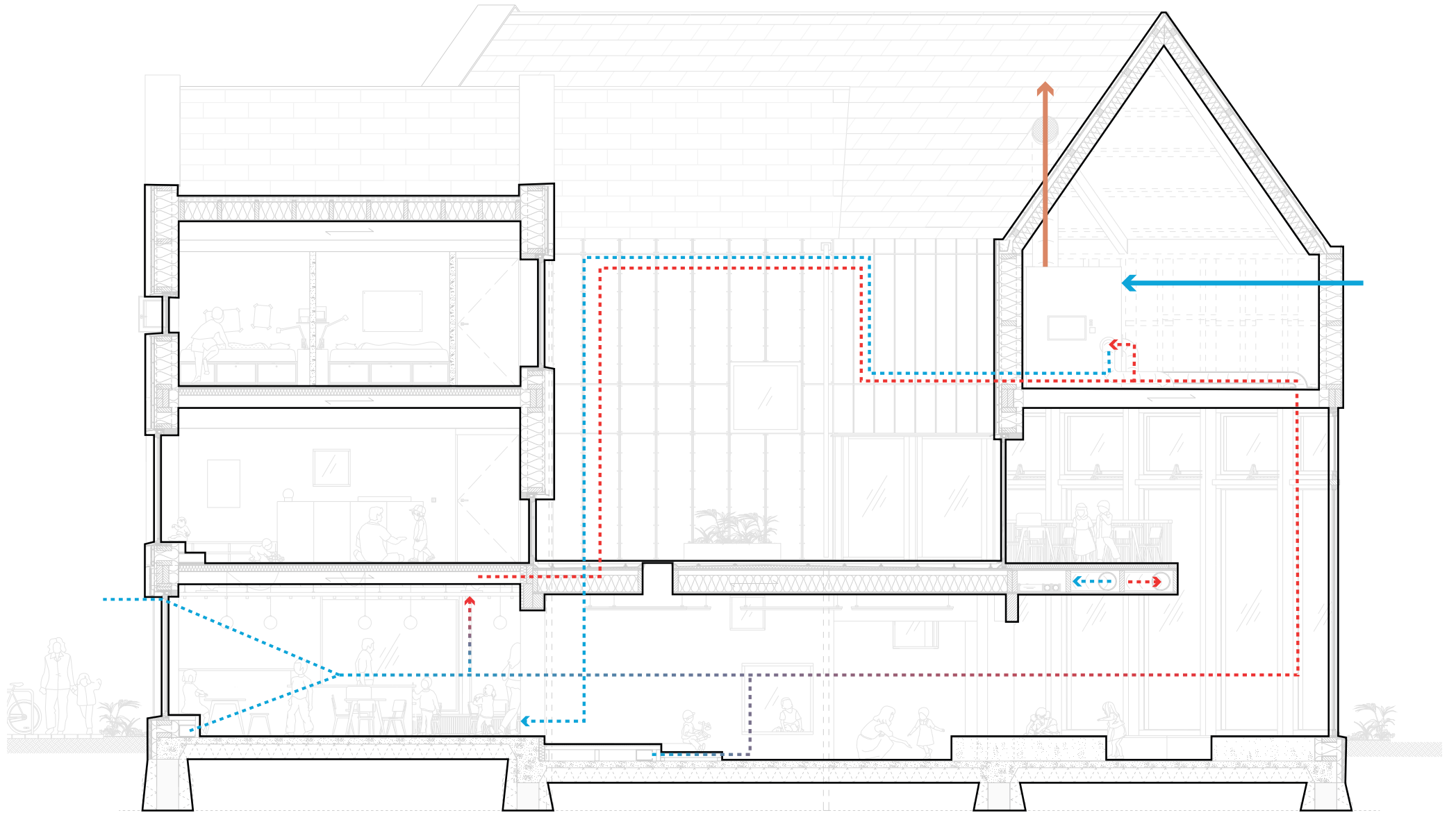

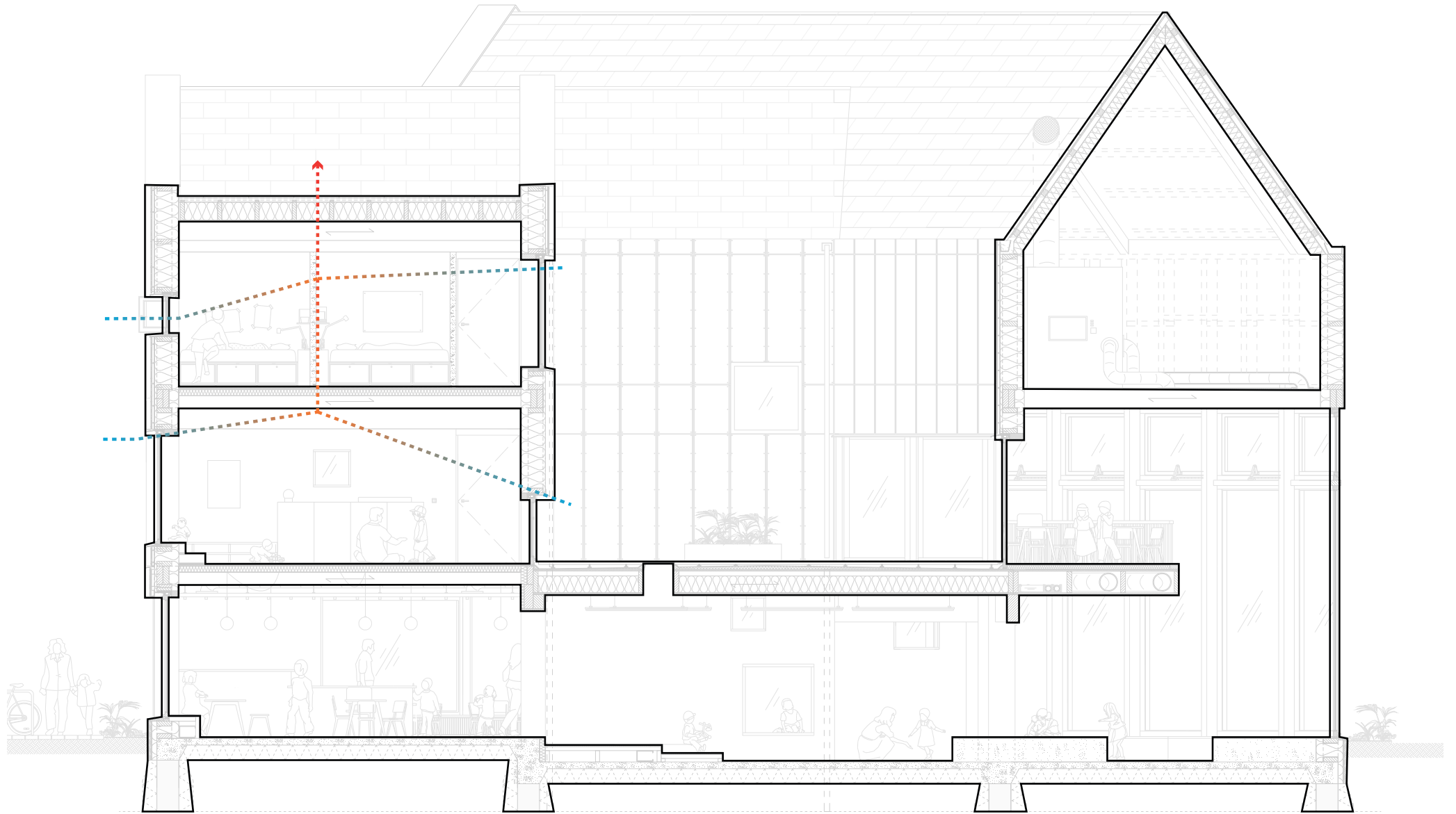

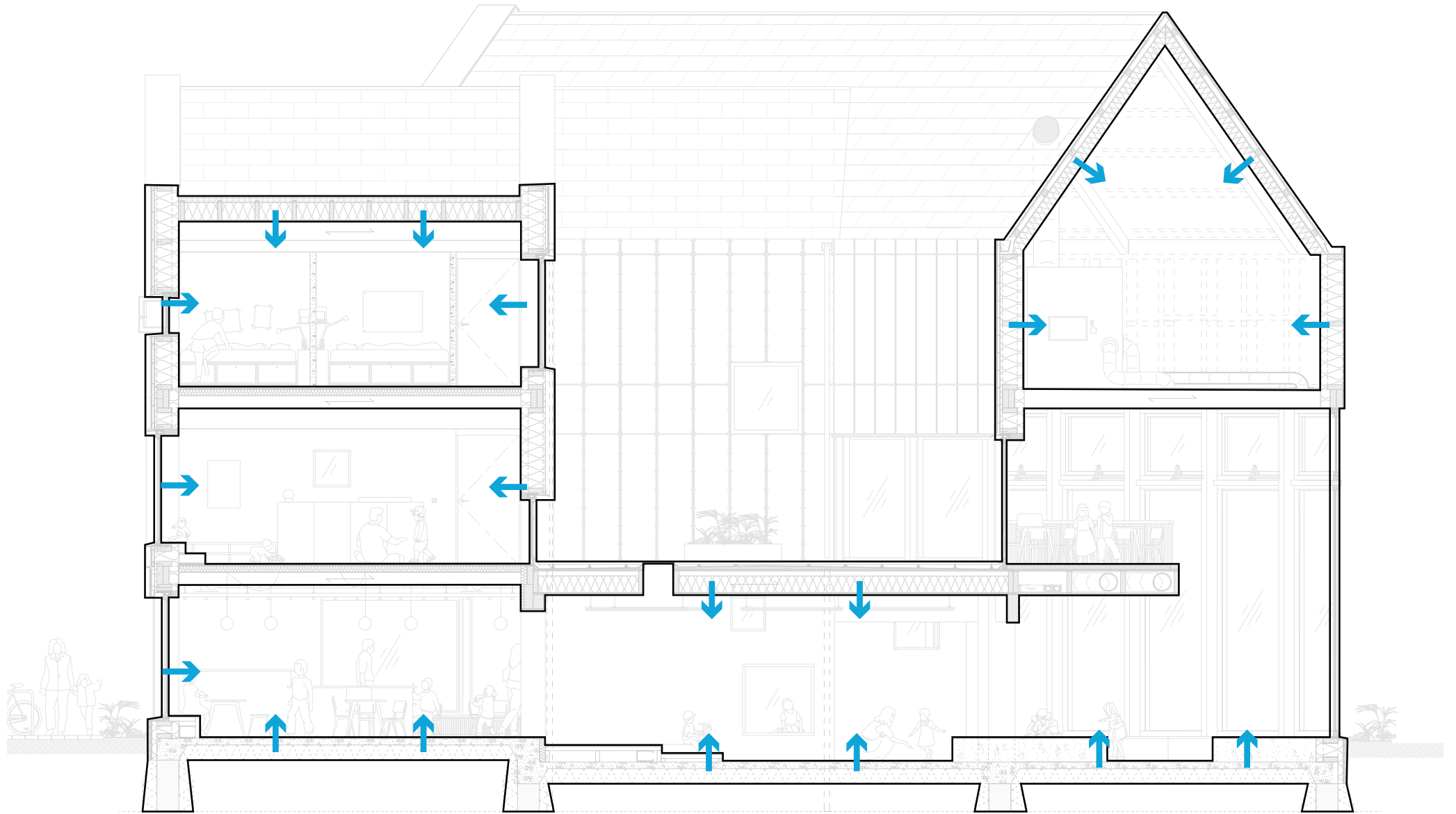

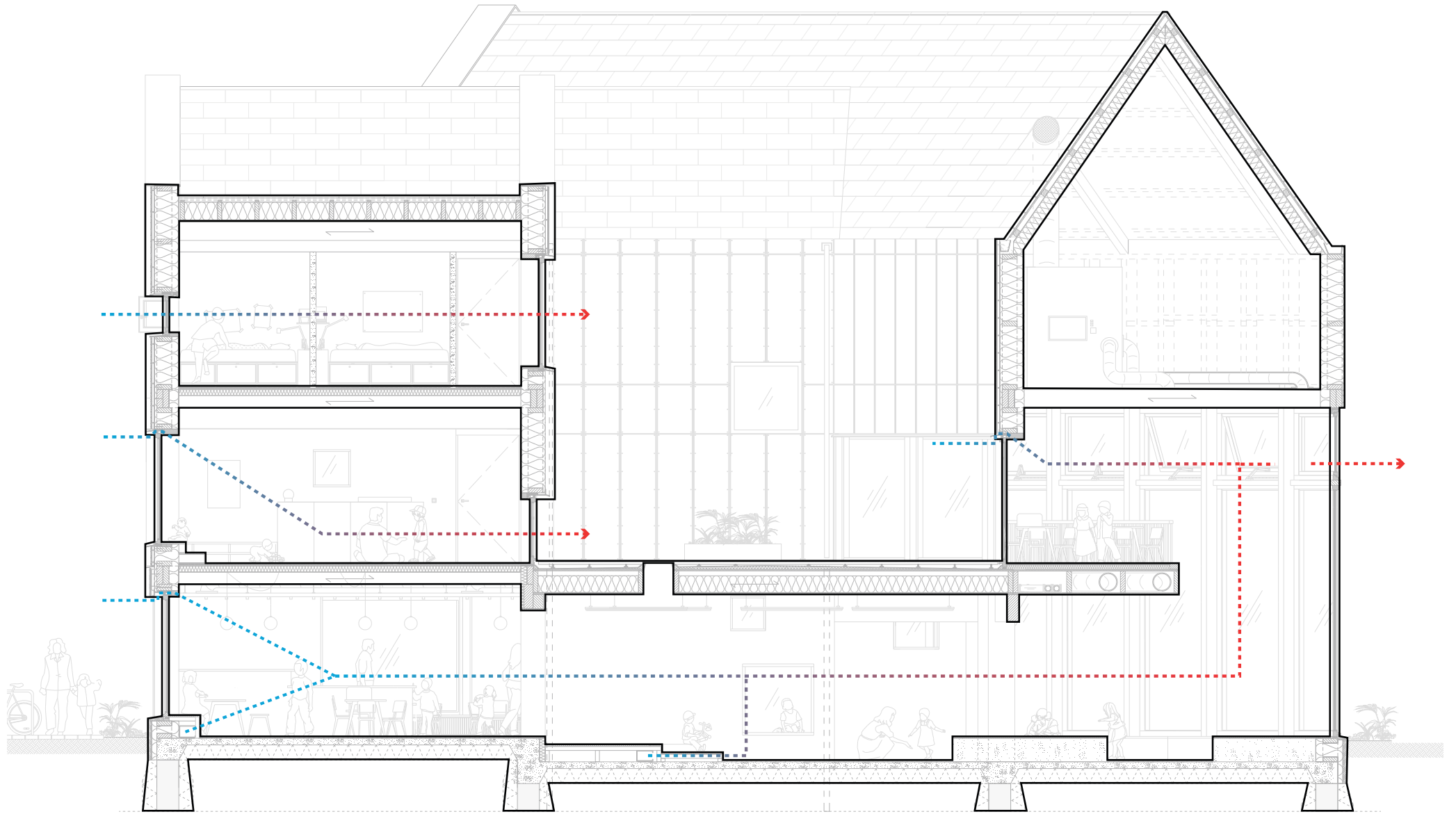













entrance private











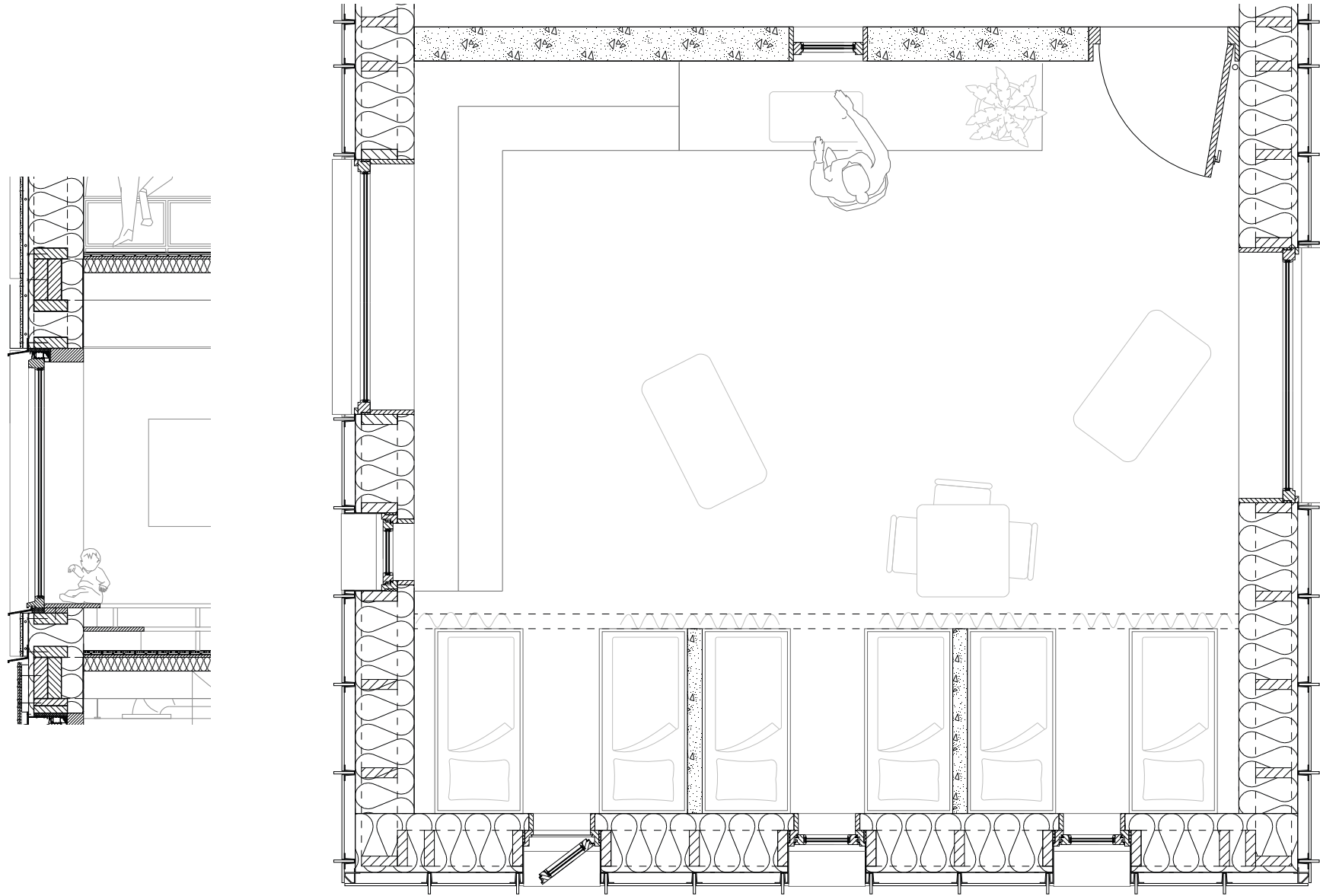







Linoleum flooring  
Dry floorheating system 25 mm  
Acoustic insulation 80 mm  
Timber floor beams c.t.c 600 mm

Viroc vertical rib 16 x 140 mm fitted into U-profile and tightened with bolts and nuts

Viroc panel 16 x 575 mm (max) screwed to U-profile

Aluminium mounting U-profile screwed into timber frame

Water barrier

Timber frame 80 x 244 with casted-in-site hempcrete 400 mm,  $R_c = 7,2 \text{ m}^2\text{K/W}$

Window sill bench

Aluminium sill

Stained accoya window frame with passive ventilation grate

Stained accoya inner finish frame

A+++ triple glazing

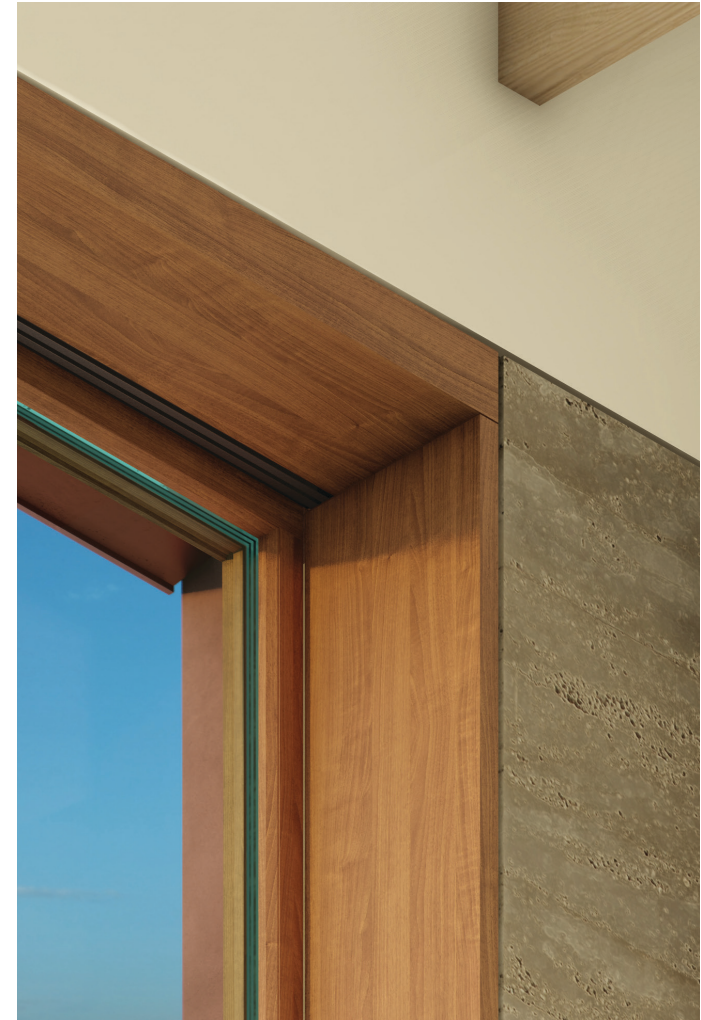
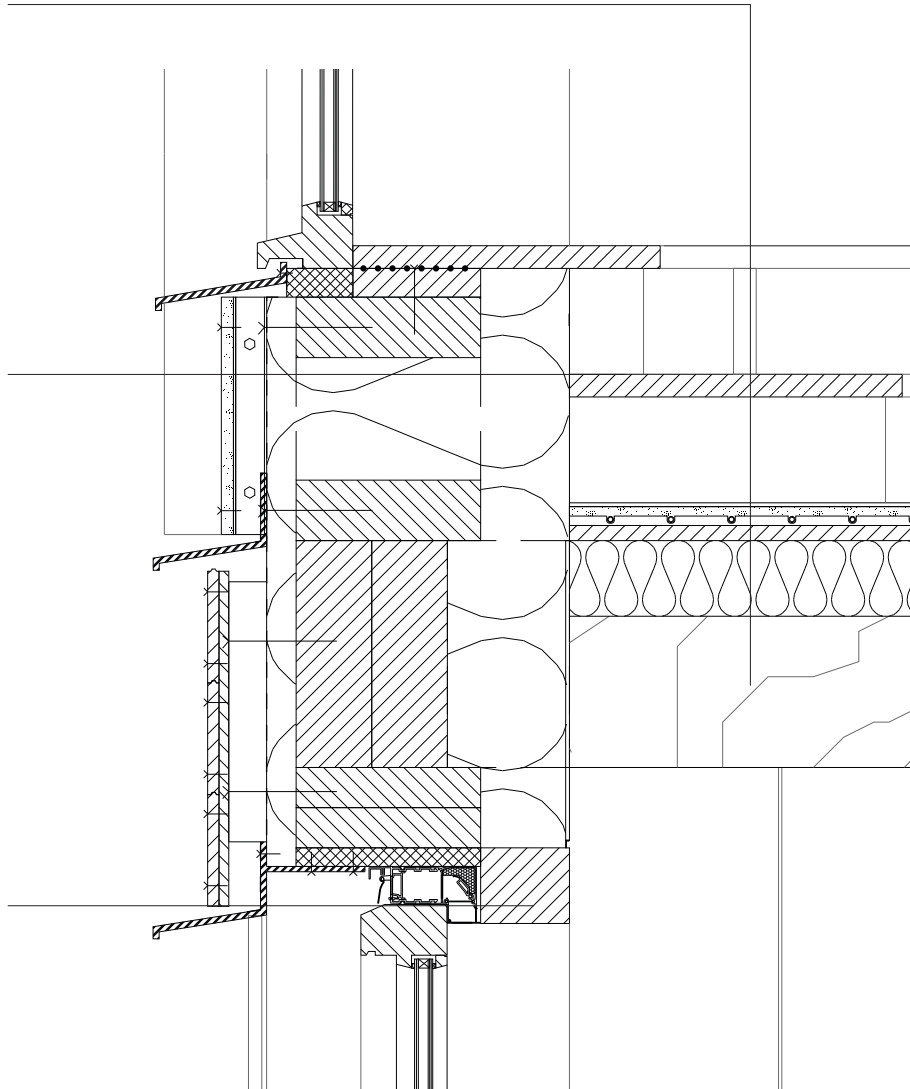

Linoleum flooring

Dry floorheating system 25 mm

Acoustic insulation 80 mm

Timber floor beams c.t.c 600 mm

Viroc vertical rib 16 x 140 mm fitted into U-profile and tightened with bolts and nuts

Viroc panel 16 x 575 mm (max) screwed to U-profile

Aluminium mounting U-profile screwed into timber frame

Water barrier

Timber frame 80 x 244 with casted-in-site hempcrete 400 mm,  $R_c = 7,2 \text{ m}^2\text{K/W}$

Window sill bench

Aluminium sill

Stained accoya window frame with passive ventilation grate

Stained accoya inner finish frame

A+++ triple glazing

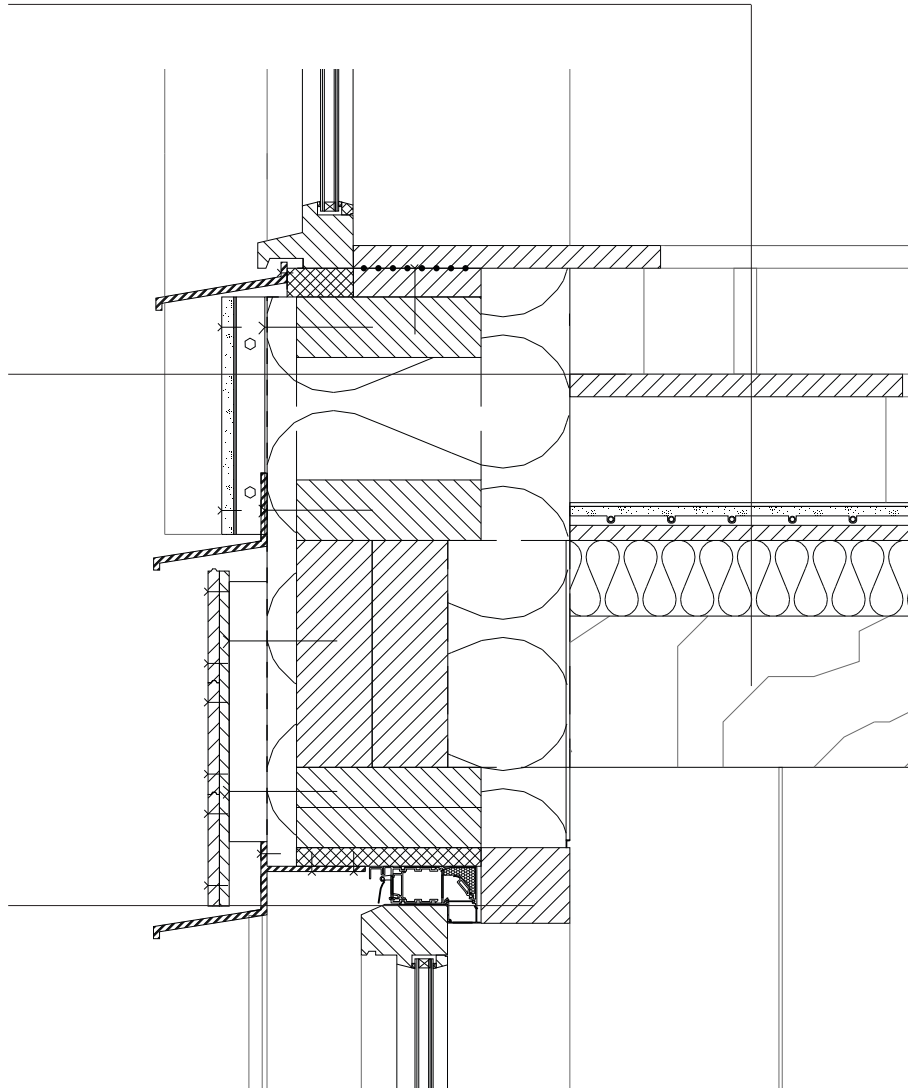

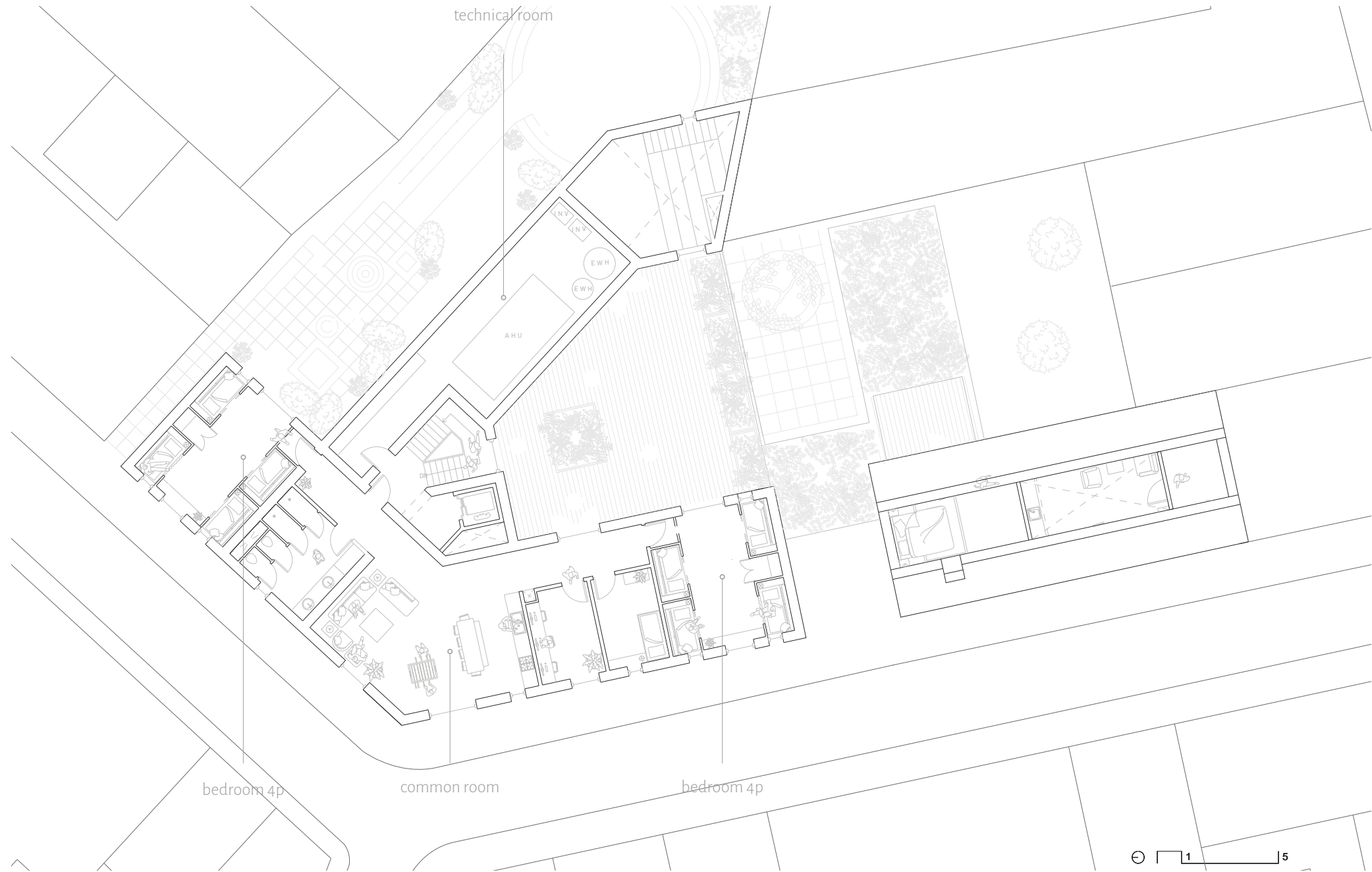

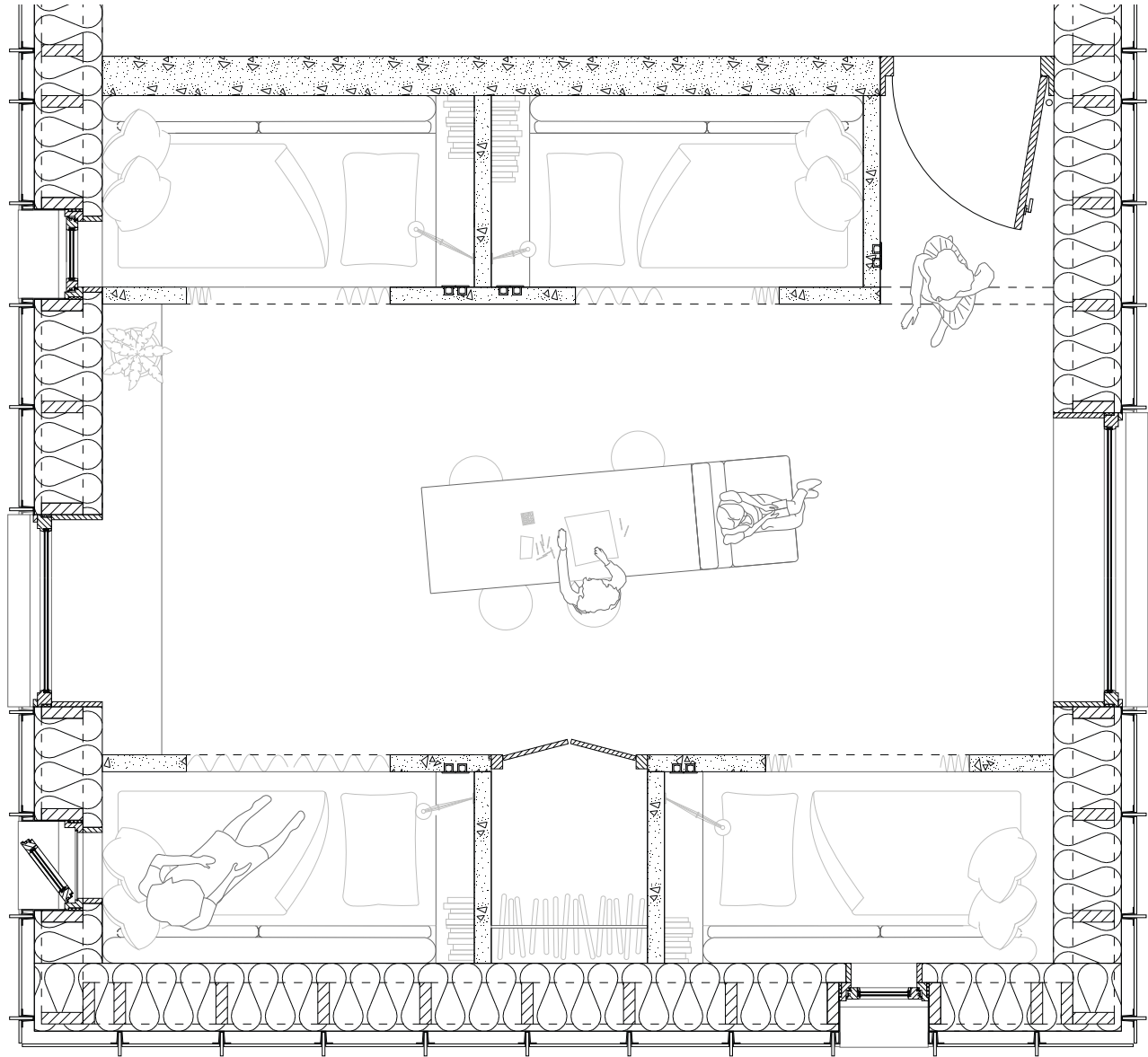
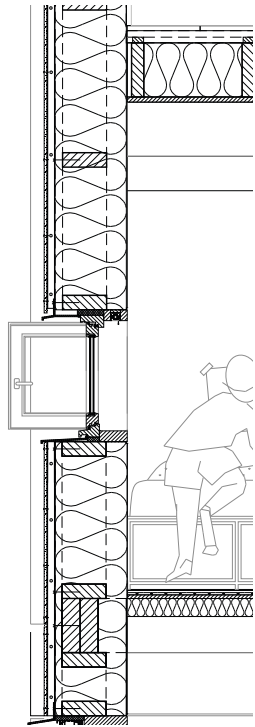







Viroc vertical rib 16 x 140 mm fitted into U-profile and tightened with bolts and nuts

Viroc panel 16 x 575 mm (max) screwed to U-profile

Aluminium mounting U-profile screwed into timber frame

Water barrier

Timber frame 80 x 244 with casted-in-site hempcrete 400 mm,  $R_c = 7,2 \text{ m}^2\text{K/W}$

Aluminium sill

Stained accoya window frame

Stained accoya inner finish frame with integrated roller blinds

A+++ triple glazing

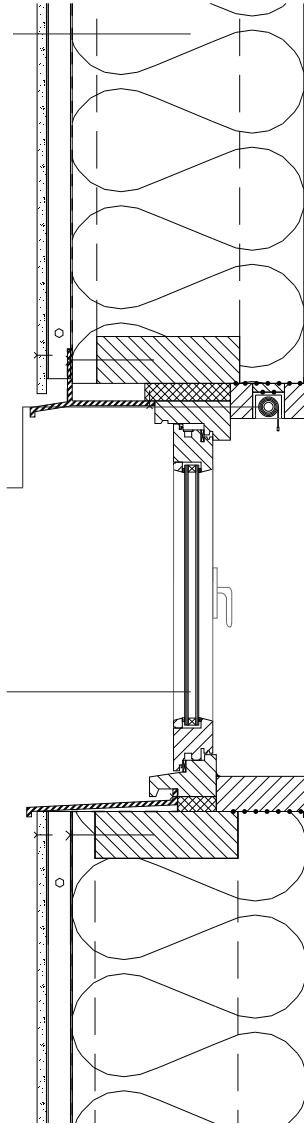



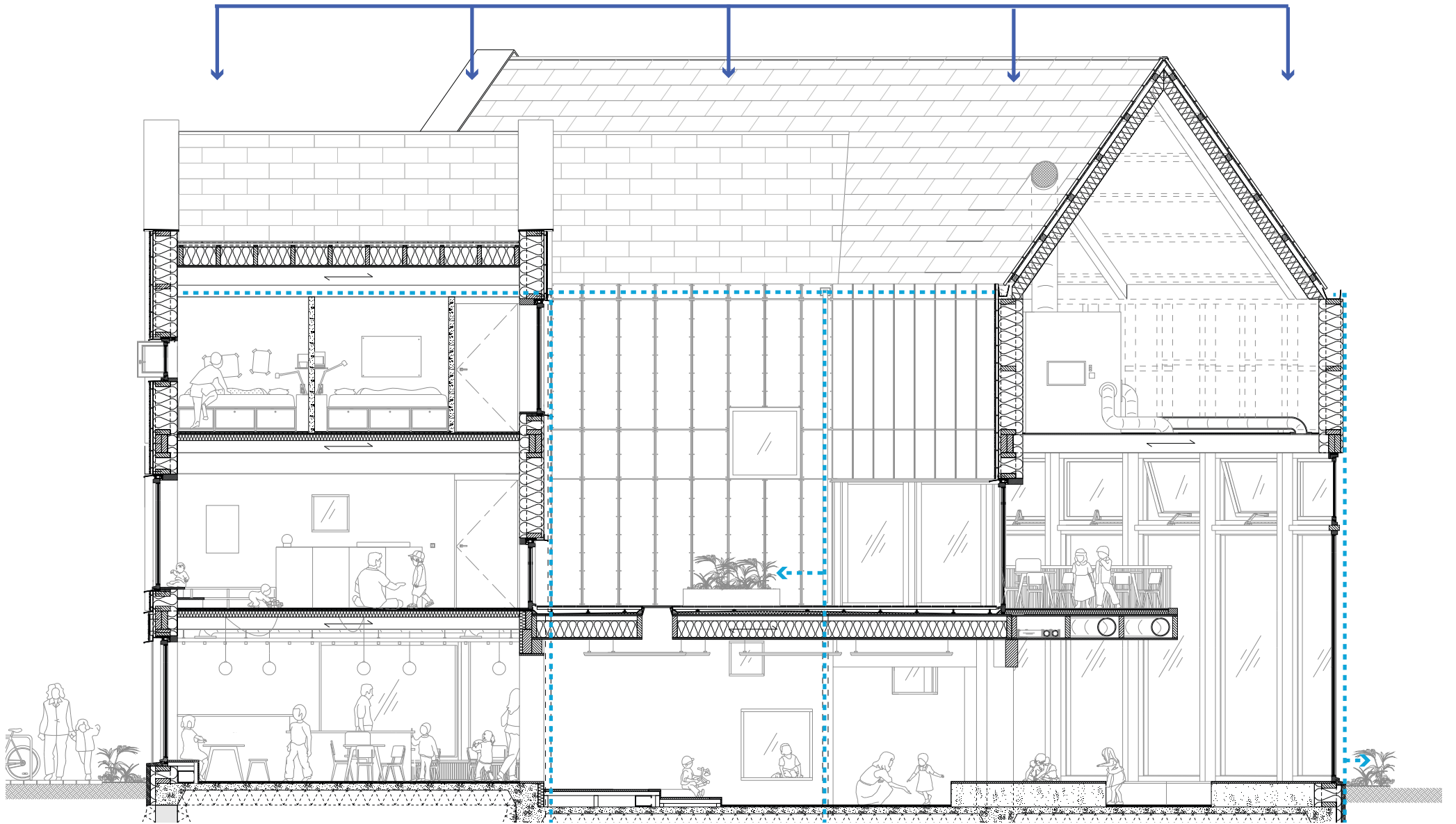



### **So who profits...?**

The city in maneuvering itself into the safe and just ring of the Doughnut Economy, attending to permanent citizens and strengthening Amsterdam's multicultural society

The local citizens in filling a shortage in after school care in the Jordaan and raising kids in a multicultural environment.

The innocent children that now live in camps without parents or basic necessities that deserve a new chance.

Home of the Innocent





Eternit



