

Associations & Assemblages
A Pattern-based Housing Group Form in Istanbul

Research&Design Reflection

The architectural design Associations and Assemblages-A Pattern-based Housing Complex, are followed by research on existing housing patterns in Istanbul. Three types of housing forms: Self-built, Street apartment and Highrise. For individual housing units, they are different in scale/volume/facade composition/land occupation. When grouped housing units land on the terrain of Istanbul, they form different patterns in plan and elevation. The research finding can be concluded as: By figure ground plan, self-built houses are more dense in land occupation, but have less demolish on original topography than street apartments and high-rises. The collision of three patterns in my site Yenidoğan, the most over-populated area of Istanbul, guides me rethinking how they can coexist in a more topo-friendly way and create possible new housing patterns.

Experiment trying associations&assemblages on housing patterns in plan and elevations, is a radical and effective approach to generate possible combinations of housing patterns, suggested by my tutor Marc and Stefano after P2'presentation. Continuously, I apply this approach to the facade patterning and spatial composition on my architectural design.

Architectural intervention starts after my research and experiments. A sketch volume model was presented to try on different associations of housing in volume. Working on the volume model inspired me to re-arranging the elevation composition, which generally is leaving the ground to self-built houses and lifting up street apartments/highrises, taking advantage of the topography on site and extending three patterns to each other. The purpose is to stop the blocking in urban tissue and demolishing on topography. The volume assemblage resulted in a housing complex with different variations of program in elevation and plan, and further influencing its structure.

To realise these cantilevers and long spans, the main structure are grouped by foundation/concrete core/mega columns/steel truss, supporting secondary steel-framed structures in the shape of each housing volume. Circulations in the grouped volume has multiple entrances on land and intersects on upper floors.

All pattern experiments require a certain scale definition and field definition. Experiment I Associations and Assemblages in Plan is in urban scale 1000 meters square with 50 meters pixel. My research at Q2 defines 1000 meters

square is my site area and 50meters square is a basic housing units group. Experiment IV Facade Patterning is in architectural scale 50 meters square with 3 meters square pixel. During Q3, I developed the 3 meters square pixel facade variations, regarding its material/composition, as a toolbox for my facade patterning. The general rule of facade patterning corresponds to the program resulted by volume assemblages. Each volume has its own composition on the facade, the process of assemblages will be reflected on the facade by the rhythm and pace difference of patterns.

Corner Workshop followed by facade patterning offered good opportunity for developing detailed structure/material/circularity. I made a structure model of parts facade in 1:20 scale to present how facade panels are placed in steel frame structure. To realise different corresponding to its interiors, different materials and their combination method are developed as detailed horizontal and vertical section drawings during Q4, with the help of my engineering tutor Pierre.

Experiment V Spatial Composition is a more radical presentation on how exterior and interior space are used by residents, and connected by architectural elements such as terrain/circulation core/facade panels/mega columns.

My Q5 is to develop more on facade composition and interiors. More living scenes are gonna happen inside behind facades, especially at intersections. Meanwhile a main structure model in whole will be produced to present general structural possibility and circulation.

Student Yu Chen

Tutors Marc Schoonderbeek
Pierre Jennen
Stefano Milani
Oscar Rommens
Filip Geerts

BORDERS&TERRITORIES
MSc3/4 studio
Academic Year 2022/23

1. What is the relation between your graduation project topic, your master track (Ar), and your master programme (MSc AUBS)?

My graduation project focuses on housing patterns and their group forms in Istanbul. This is a challenge for me to combine urban research, architectural design and building technologies into one design. The approach I take is housing patterns, in three different scales. Urban scale patterns concern more the relations between housing units and topography. Architectural patterns focus more on facade composition and program. Facade patterns concern more detailed building technologies and material. In conclusion, my graduation project requires knowledge in architecture as well as urban design and building technology.

2. How did your research influence your design/recommendations and how did the design/recommendations influence your research?

My research on existing housing patterns in Istanbul helped me realise the housing pattern collision really happening in Yenidoğan, which is the problem I wish to tackle on an urban scale. Therefore I promote my intervention strategy of assemblage and association in architectural volume. Later experiments on facade patterning and spatial composition are more like an extension of my pattern research.

3. How do you assess the value of your way of working (your approach, your used methods, used methodology)?

My design method has been developed several times as the working objects scale from urban, architectural to interior. With the guidance and suggestions given by my tutors, the design method of associations and assemblages offers new types of housing patterns and new border conditions with topography different from the existing, which is the main purpose of my graduation project. I consider it works as an effective design method.

4. How do you assess the academic and societal value, scope and implication of your graduation project, including ethical aspects?

In the exact site of Yenidoğan, original self-built houses have been demolished by developers to make space for high-rise construction. Actually several high-rises have already been built in the middle of self-built neighbourhoods and street apartment neighbourhoods. They, together with their giant concrete platforms, act as a wall blocking the urban tissue and erasing topographic features. My graduation project works as an alternative housing form, replacing the high-rise plan they're gonna construct. The starting point of my project decides that it emphasises more social value than academic value. Similar research and design must have been made more detailedly than I did in patterning. However, what make it special is the urban, or say social value it will create in such overpopulated region with wonderful topography.

5. How do you assess the value of the transferability of your project results?

Given the process of association and assemblages, design outcomes are not fixed in the case of my project, therefore what I present is only one possible combination of patterning. Depending on the specific site and context, my design strategies can be applied to give different results. In fact, during the site tour in Istanbul, many interested locations were found with housing pattern collision, especially in urban borders with rural areas. My project would work similarly in those areas, or in other regions with housing pattern collision.

6. What makes my housing complex special from existing high-rises in Istanbul, or other residential high-rises in different regions?

The keypoint of my project is the pattern toolbox and volume assemblage strategy I developed. By the process of volume assemblage, my complex combines spatial configurations and circulation from both existing street apartments and high-rises. Therefore it offers more variations in housing types and public activities. Meanwhile those variations will reflect on its facade patterning, sourcing from my pattern toolbox.

Research _ Current housing patterns of Istanbul

Experiment I/ II/ III _ Association and assemblages in plan/elevation

Volume on Site _ Group form/Program/Structure/Circulation

Experiment IV _ Facade patterning

Corner Model _ Detailed structure/Material/Circularity/Climate

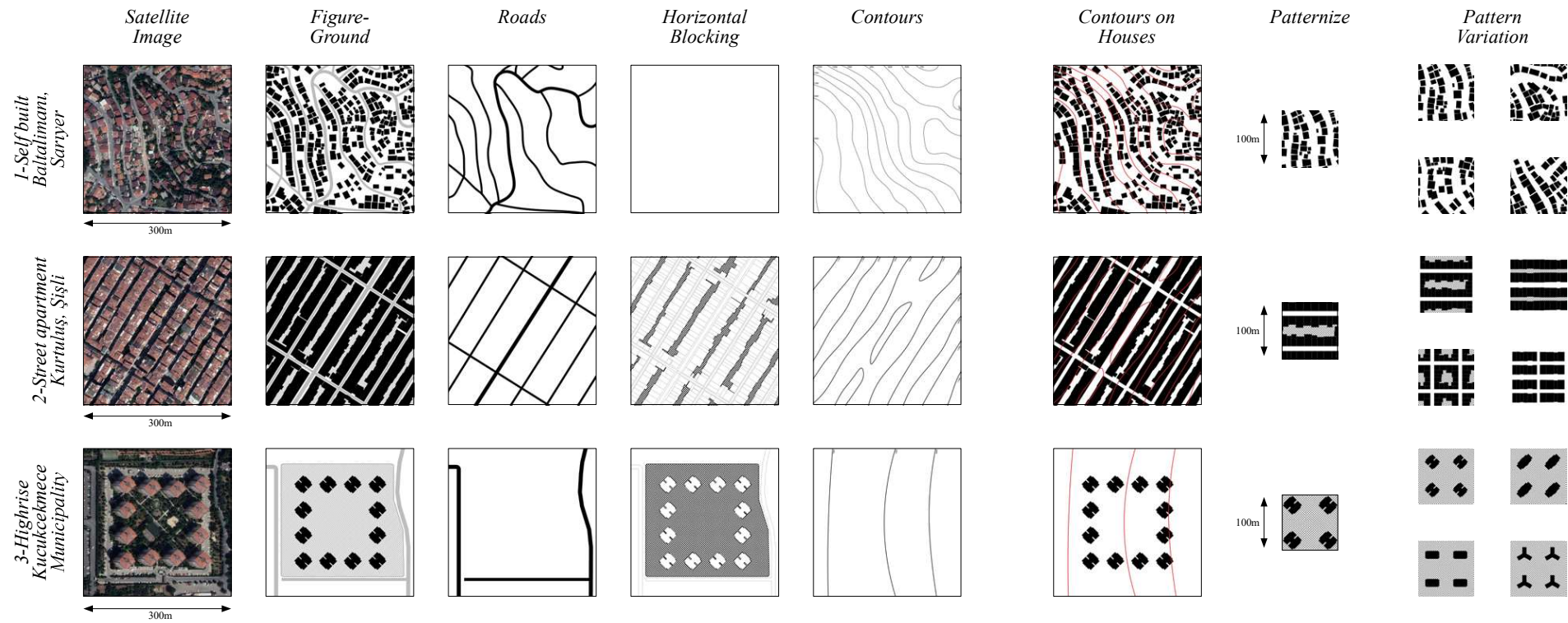

Research_ Current housing patterns of Istanbul

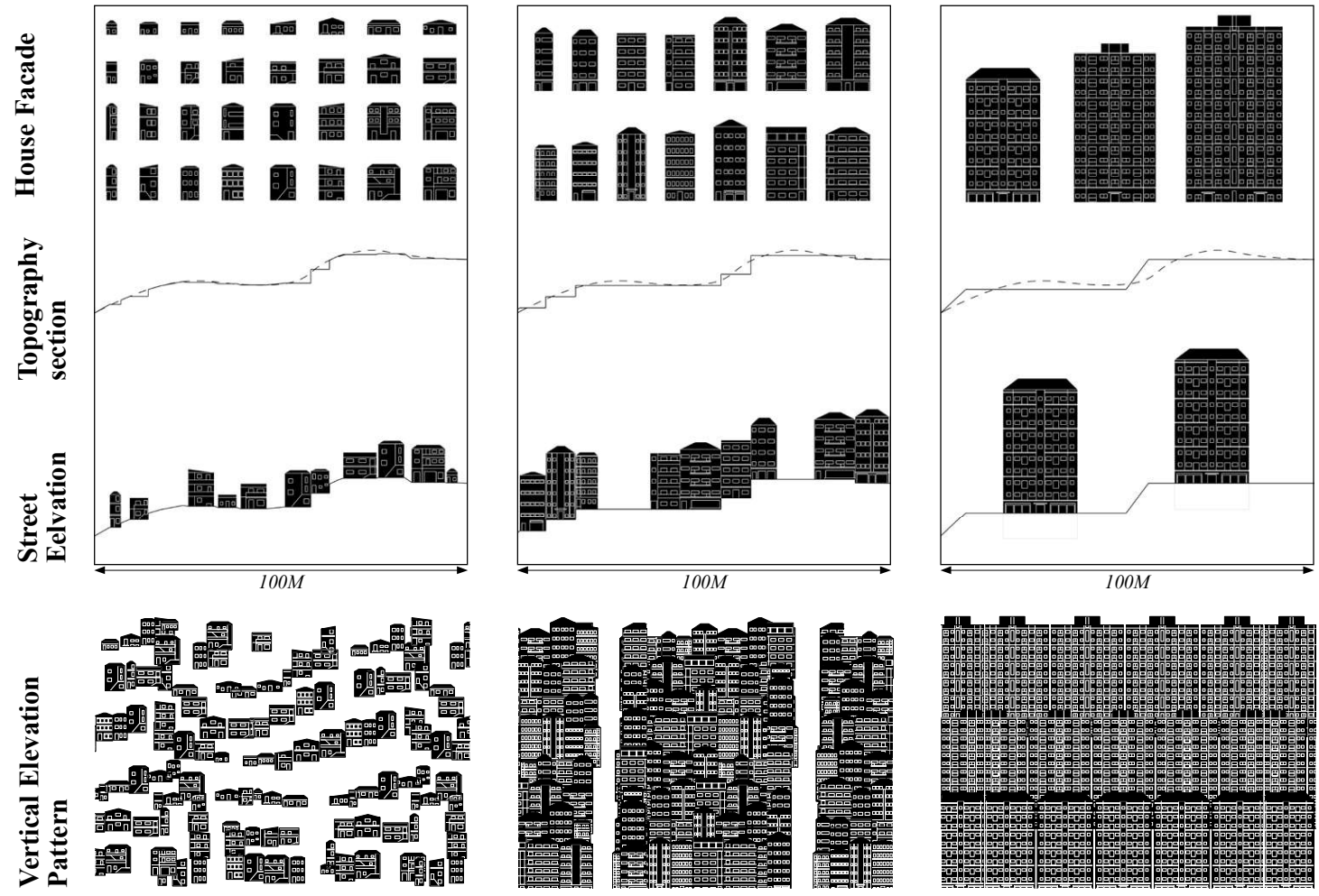

Research_ Current housing patterns of Istanbul

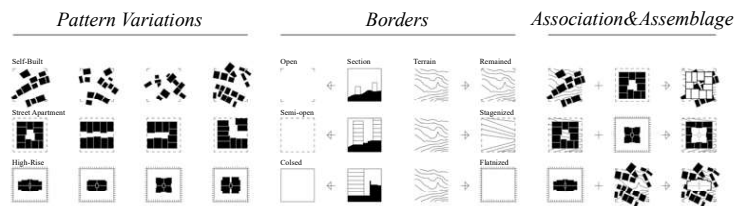
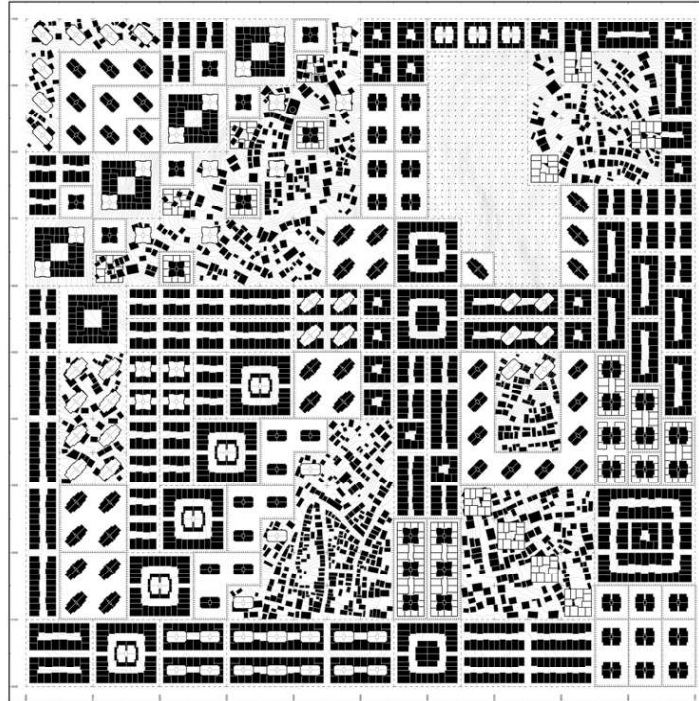

Experiment I _ Association and assemblages in plan

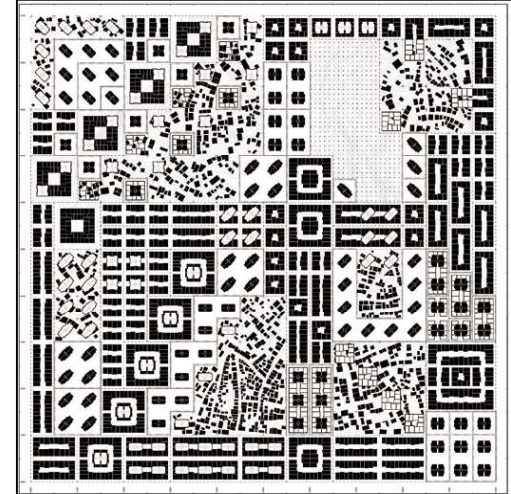
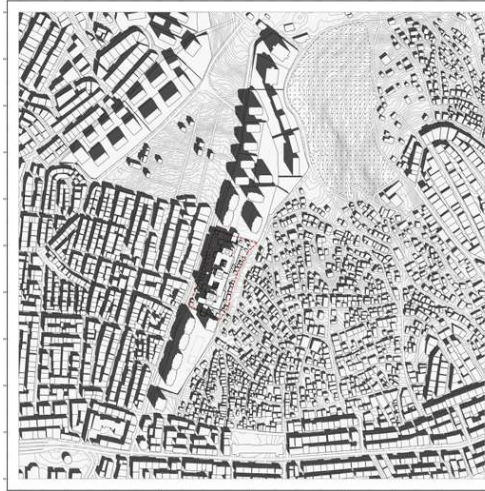

Experiment I _ Association and assemblages in plan

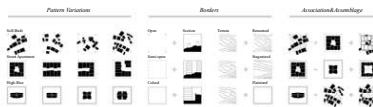
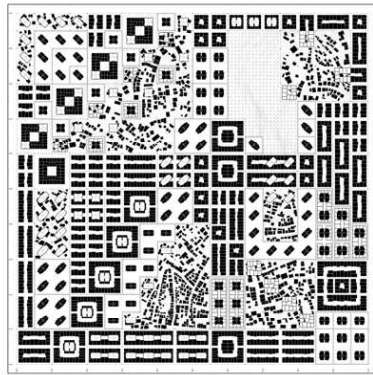

Housing Pattern Experiment I
Association & Assemblages in Plan

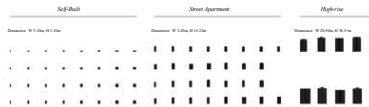
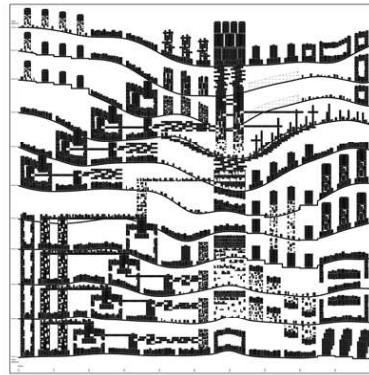

Housing Pattern Experiment II
Association & Assemblages in Elevation

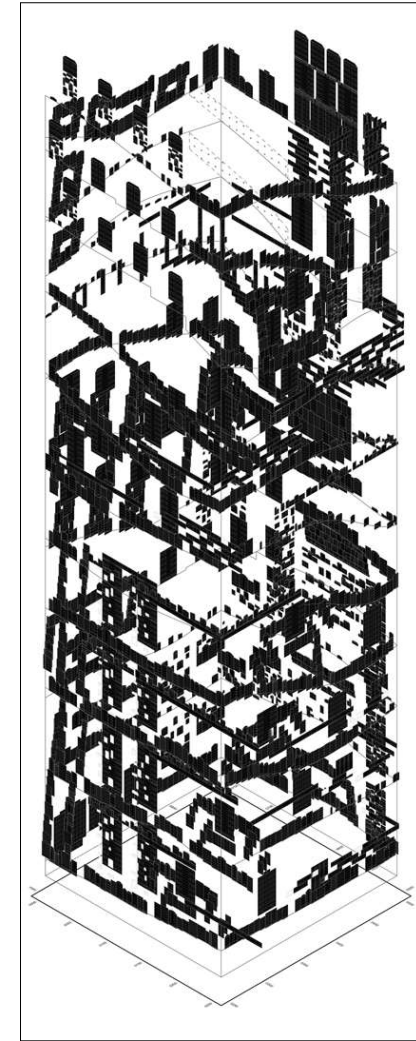

Housing Pattern Experiment III
Association & Assemblages in Elevation

Experiment I/ II/ III _ Association and assemblages in plan/elevation

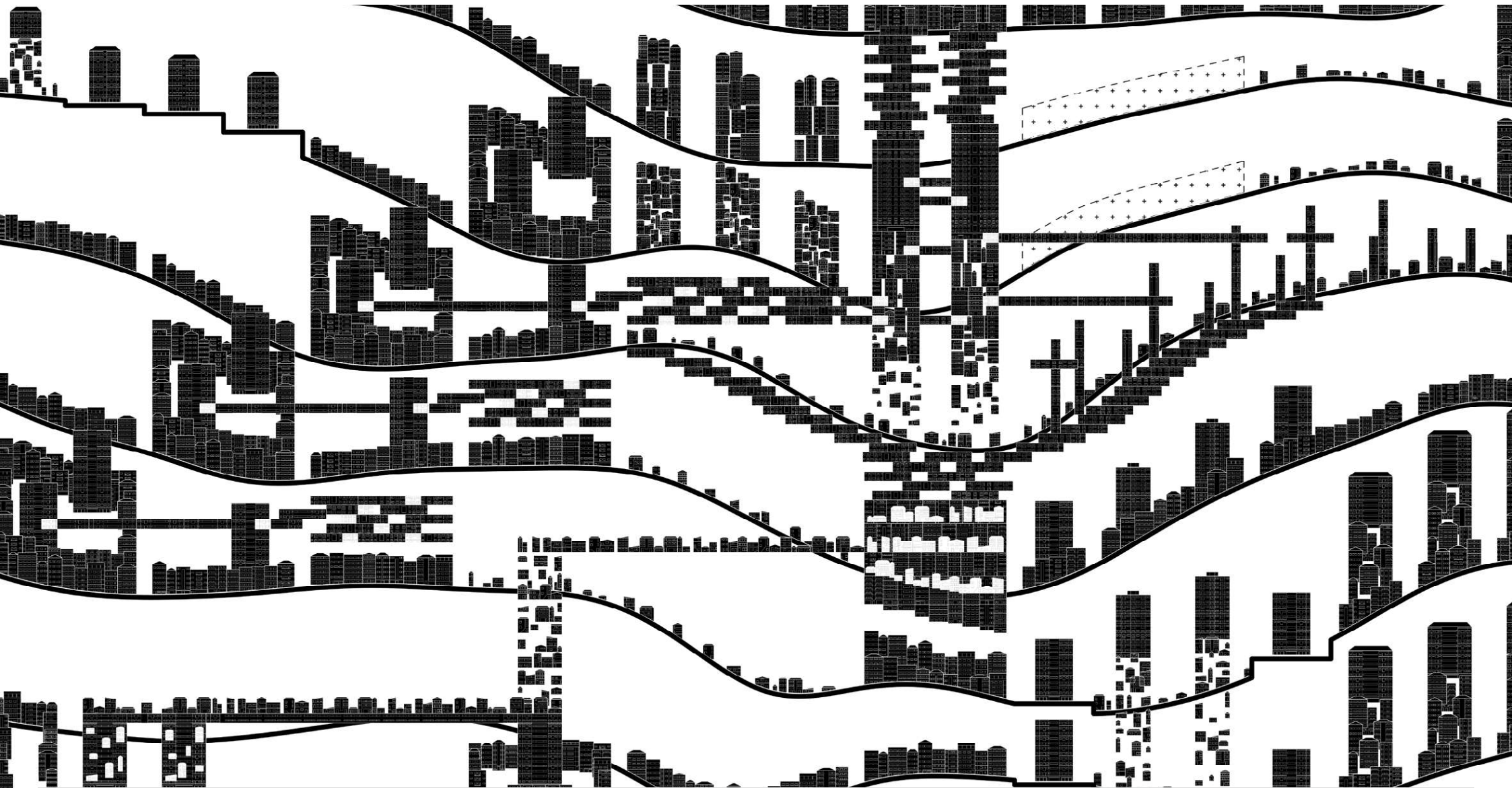

Experiment II Association and assemblages in elevation

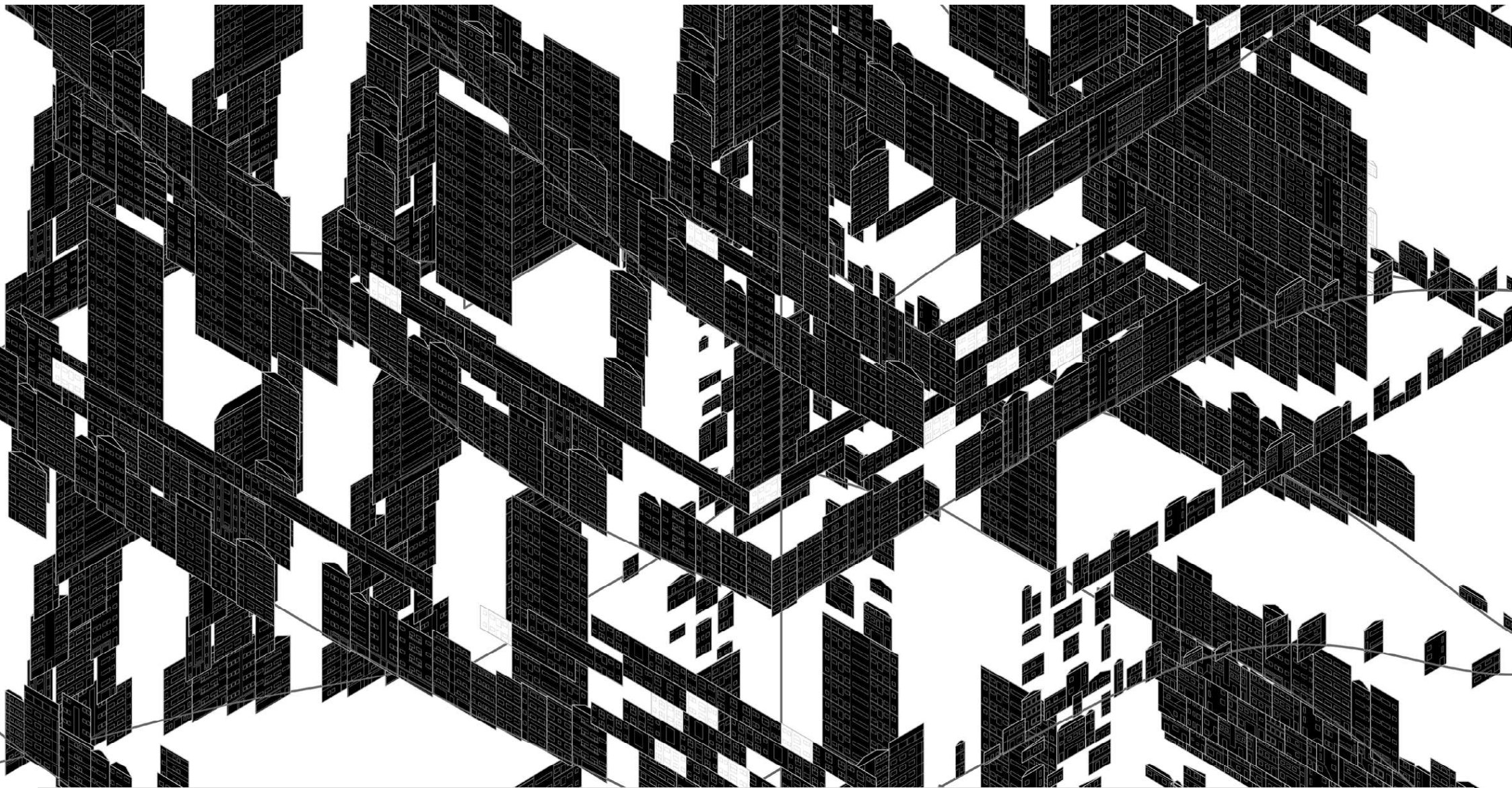

Experiment III Association and assemblages in elevation

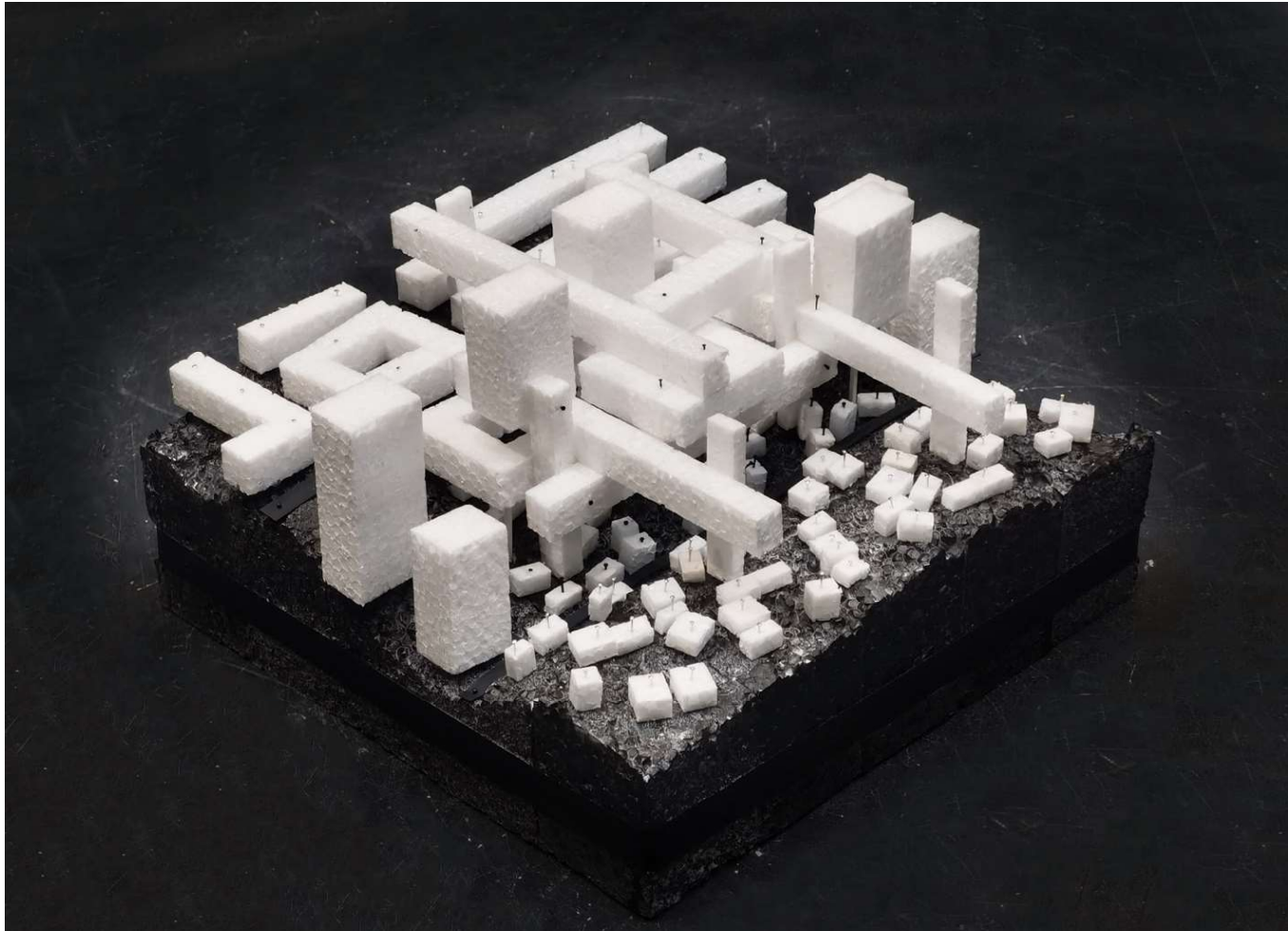

Volume on Site__Group form

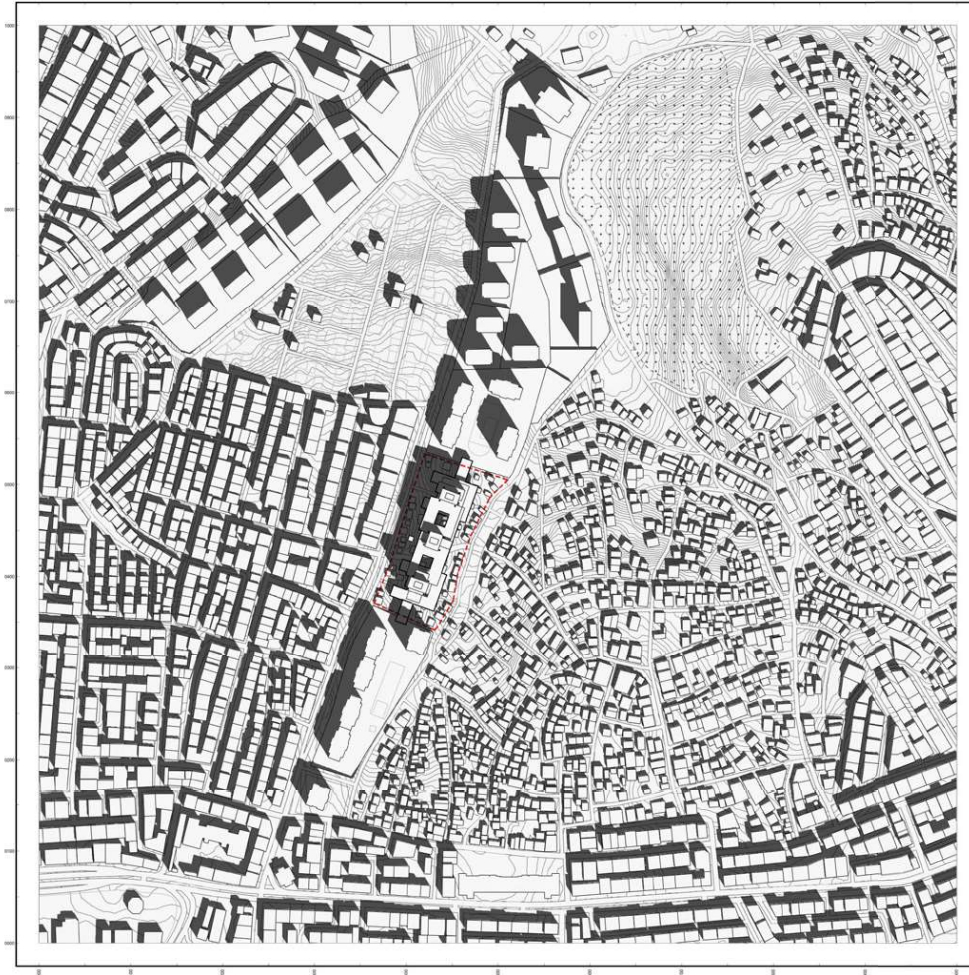

Volume on Site__Site plan

Street Apartments

Site

Self-builts

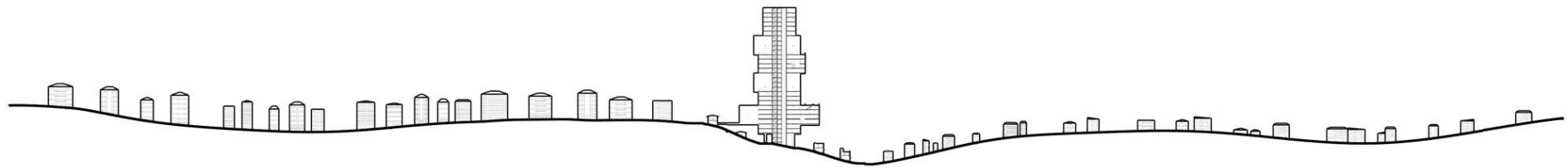

High-rises

Site

High-rises

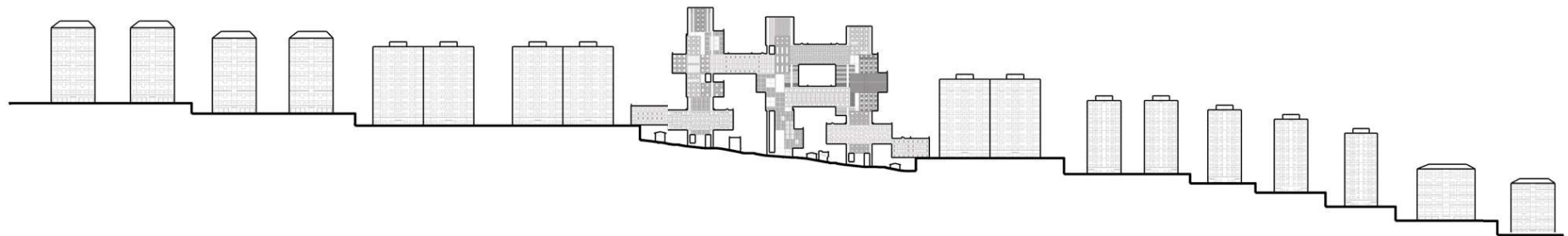

1000M

Volume on Site__Site section

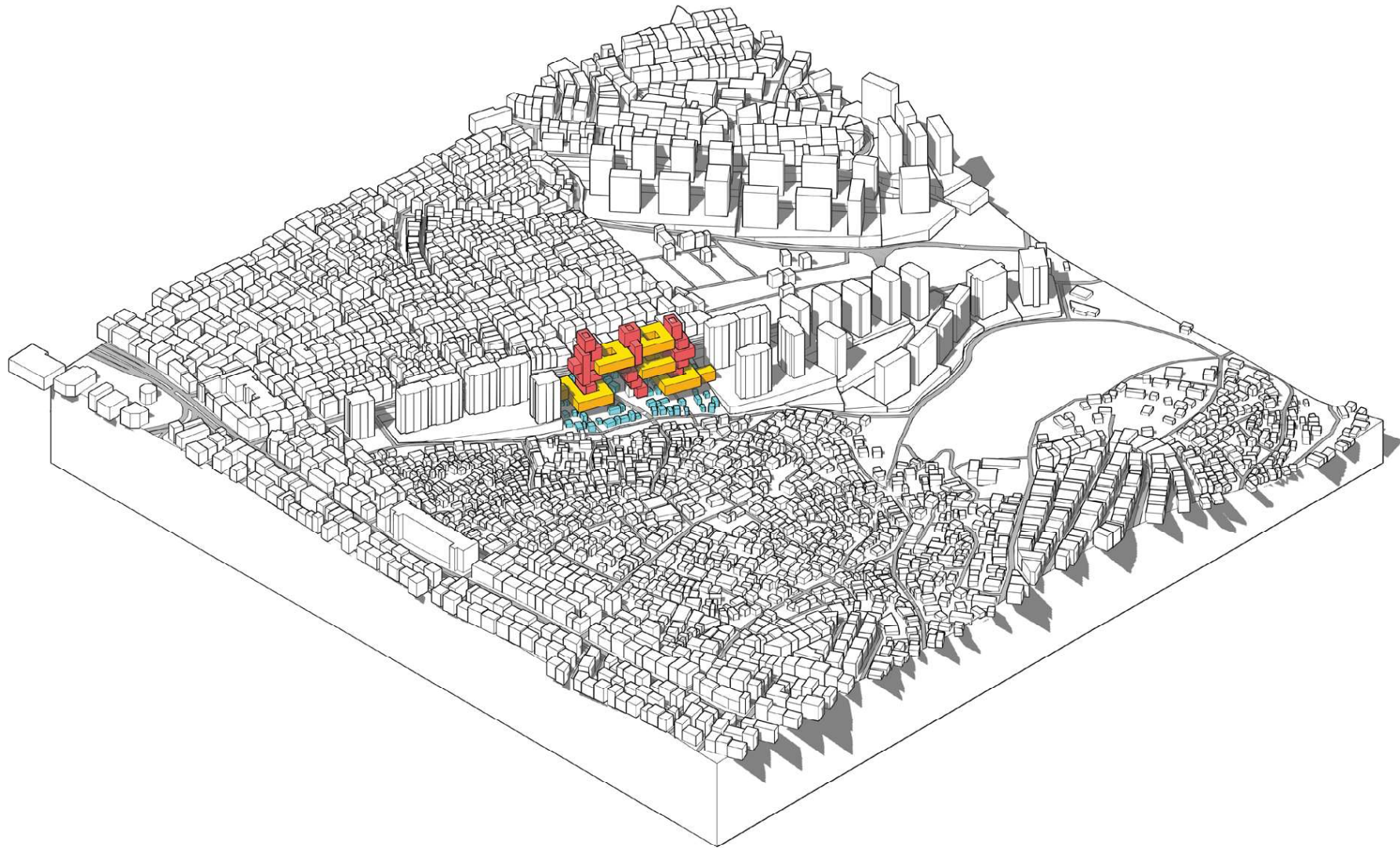

Volume on Site_Perspective

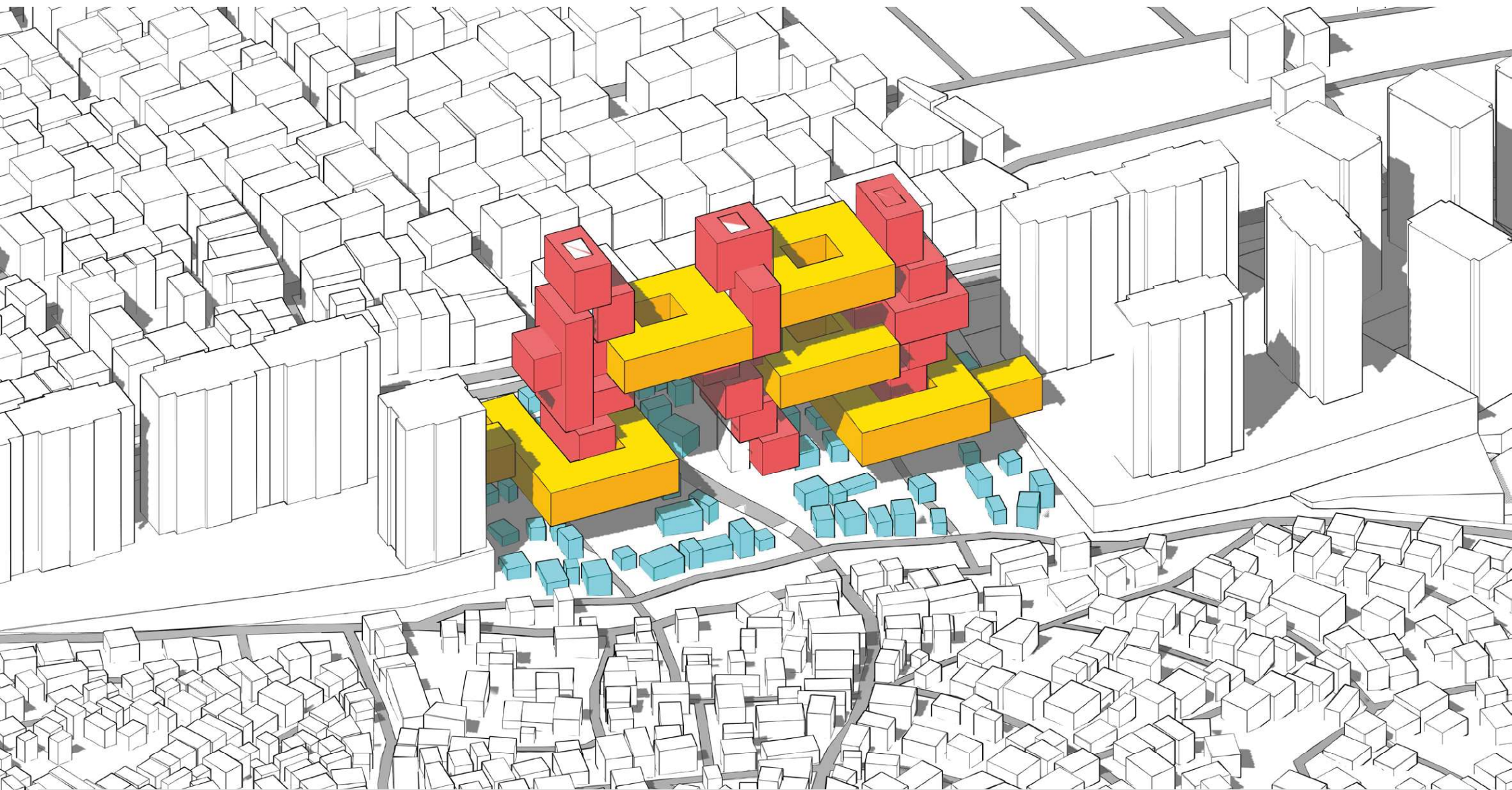

Volume on Site Perspective

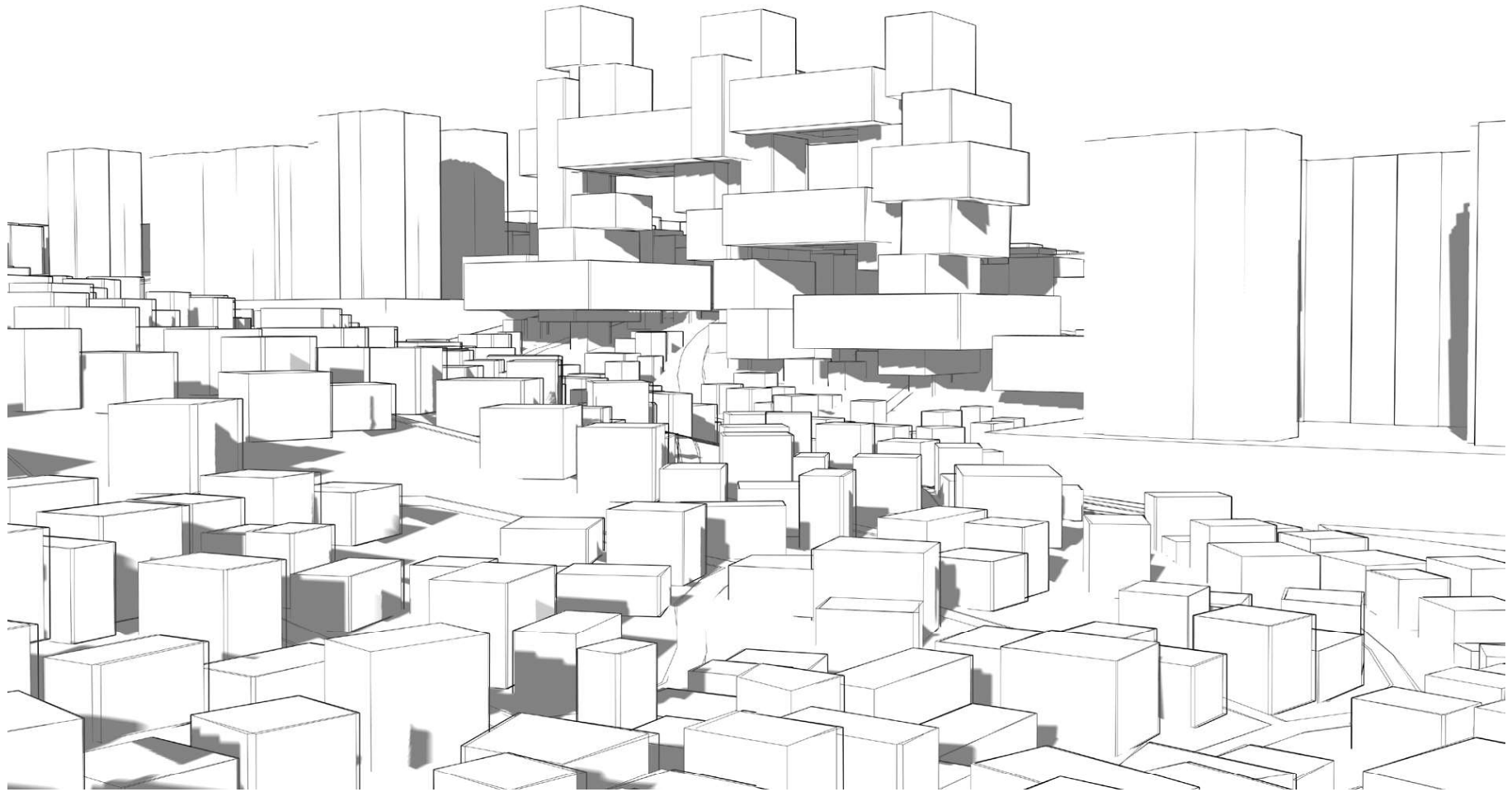

Volume on Site__Perspective

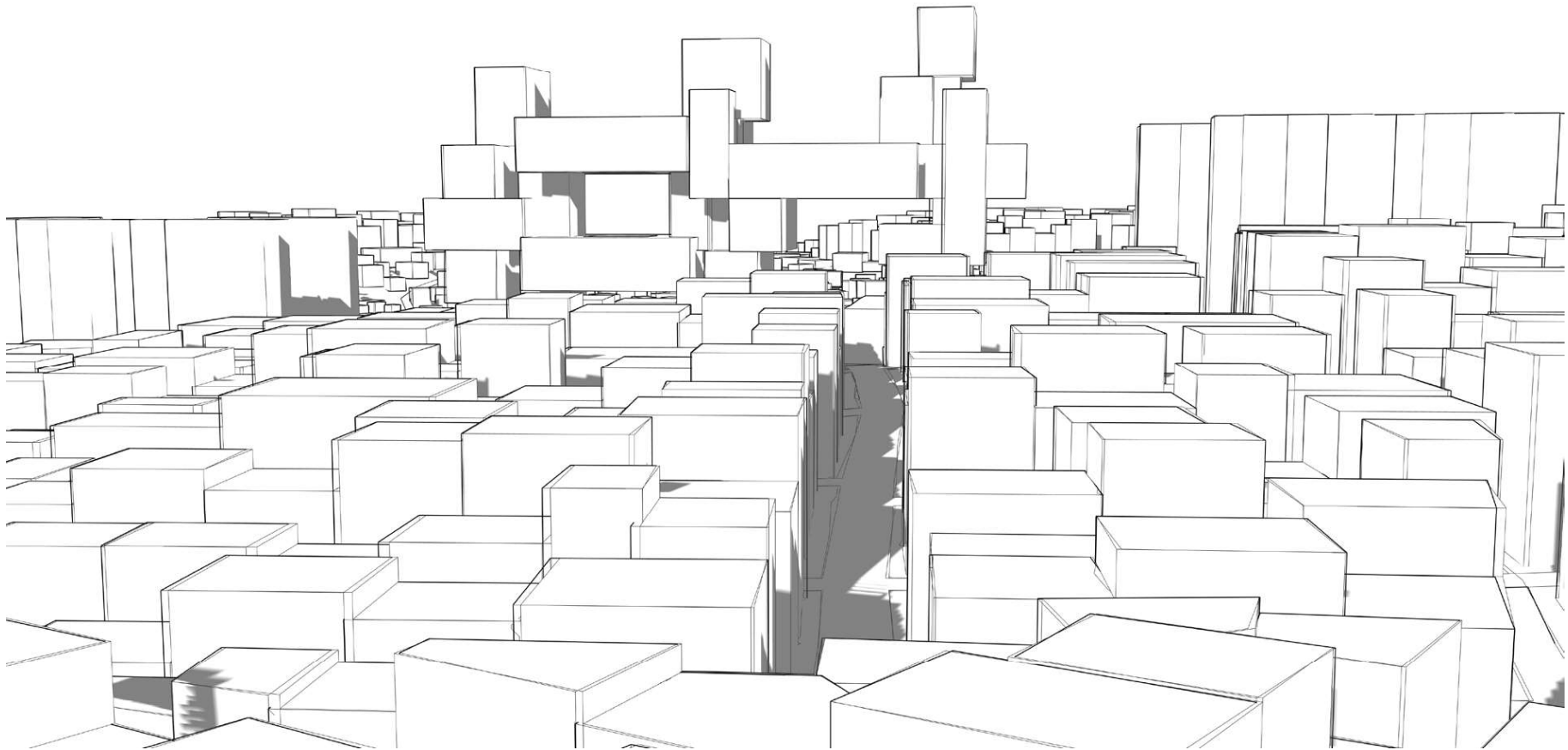

Volume on Site__Perspective

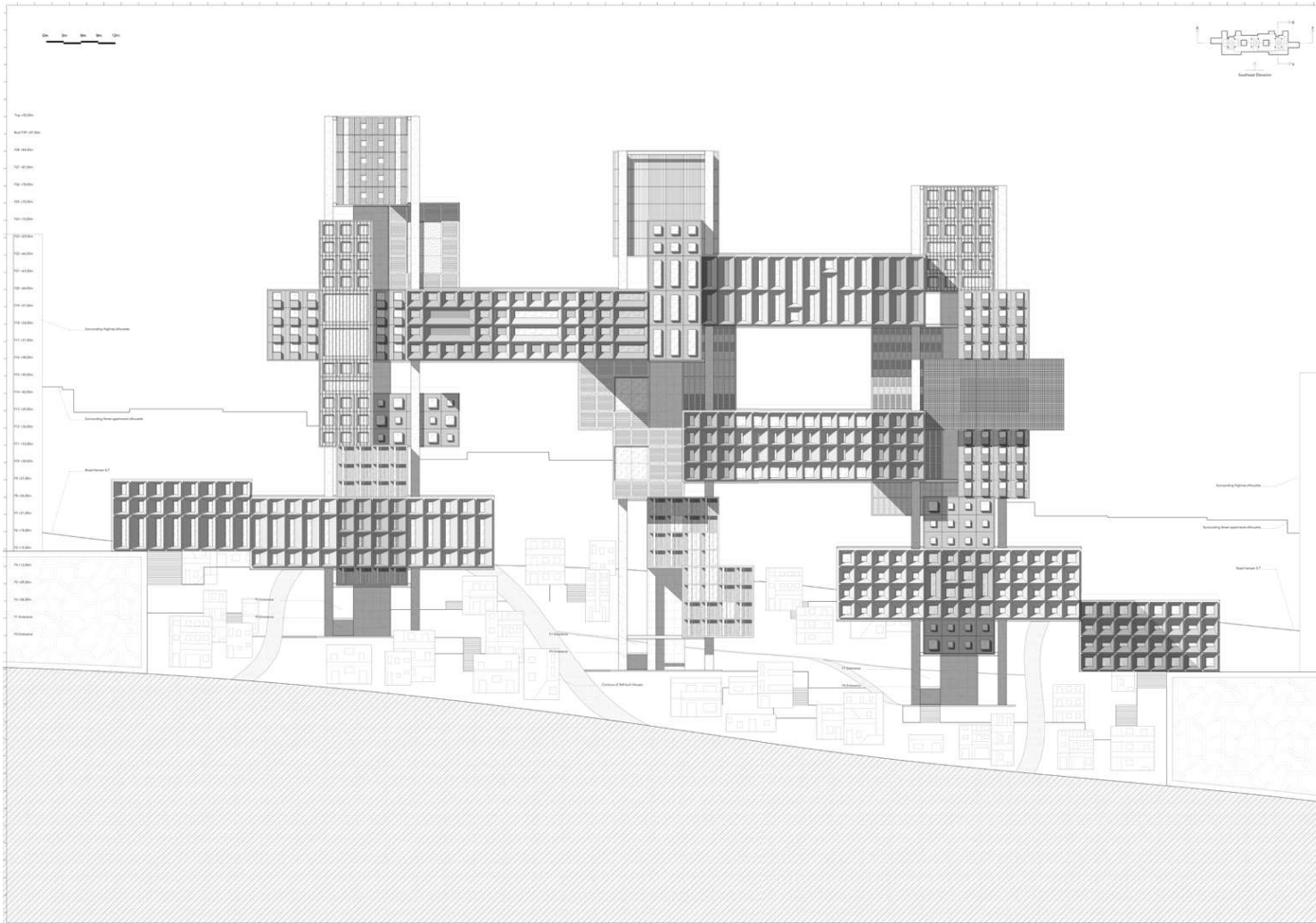

Volume on Site__Eelvation

F18 +54m

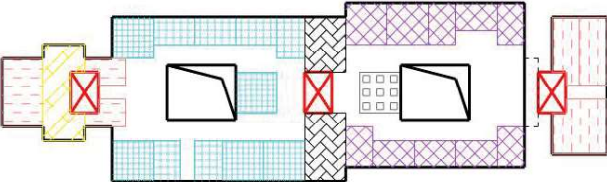

- Gym
- Bar
- Restruant&shops
- Patio
- Inddoors playground
- 1-bedroom flat
- 2-bedroom flat

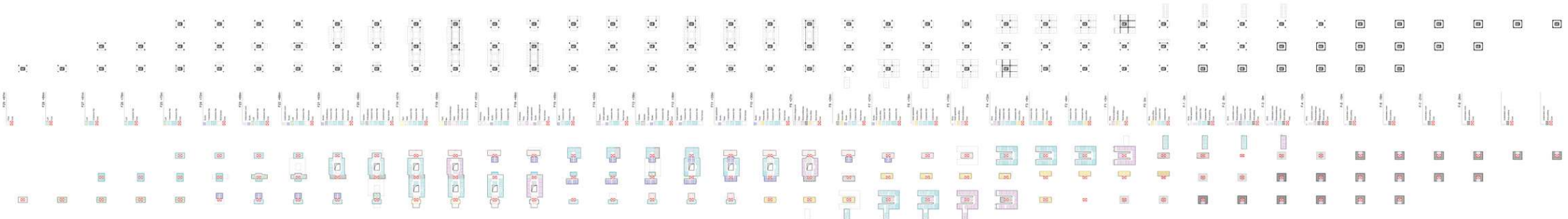
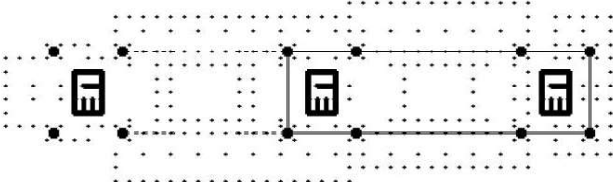

Volume on Site__Program in plan

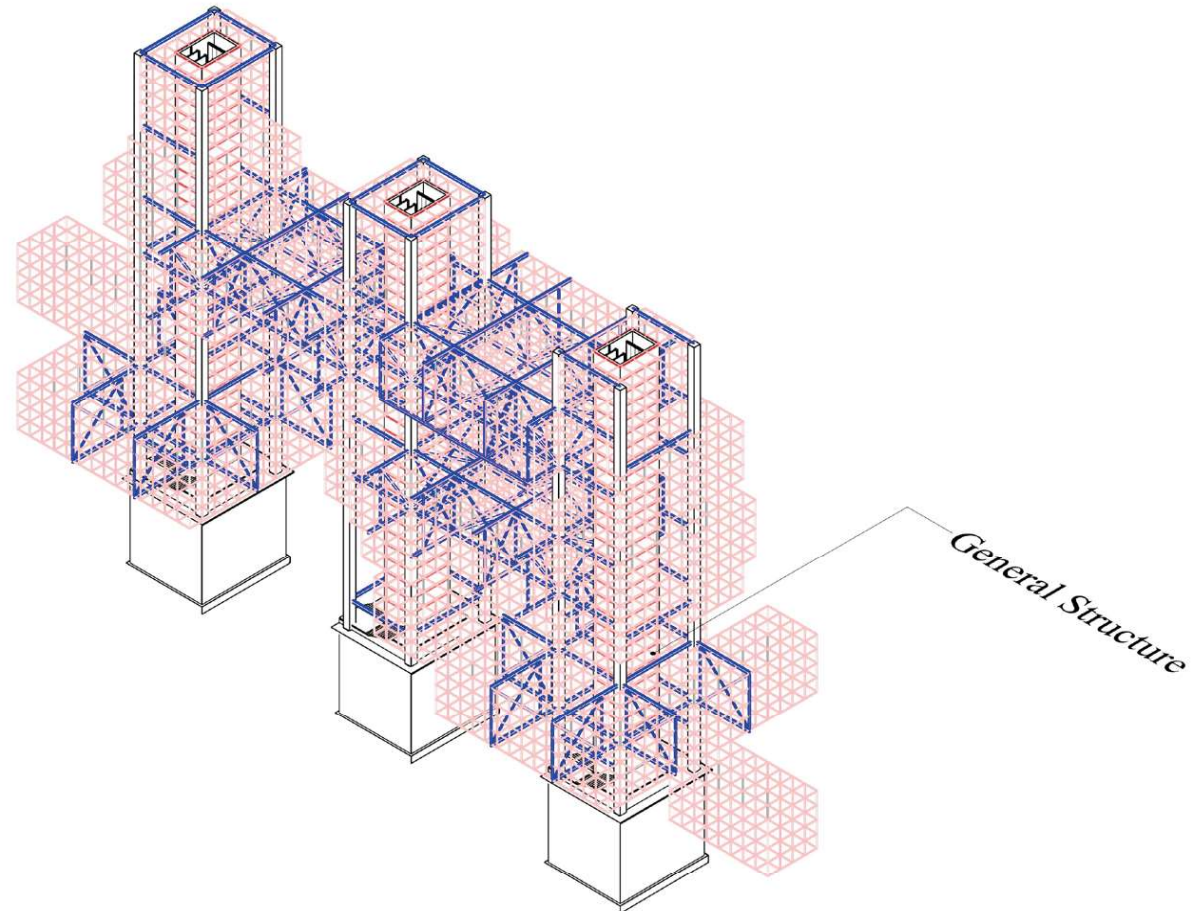

Volume Assemblage__Structure

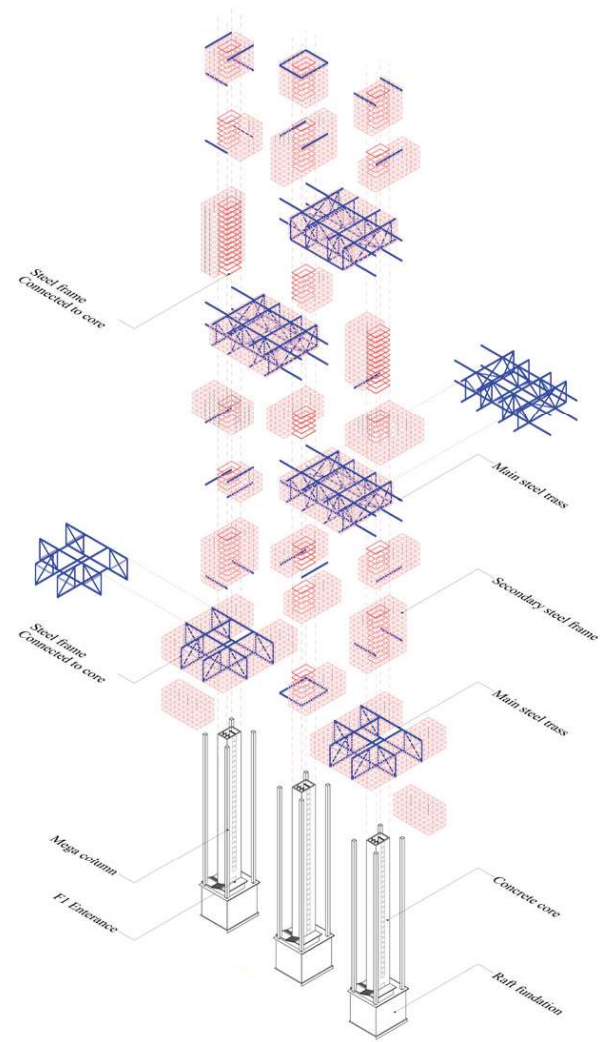

Volume Assemblage__Structure

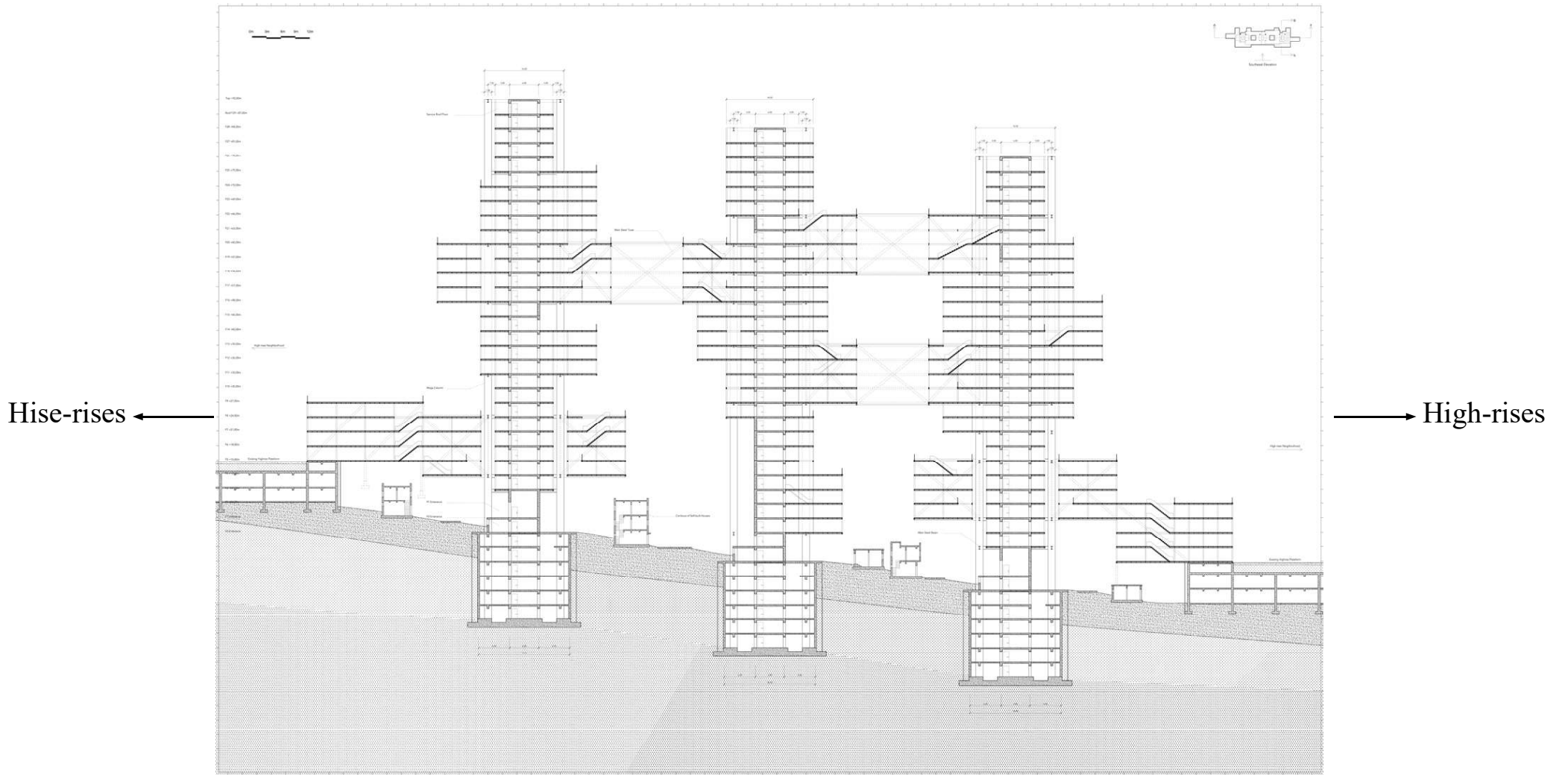

Structural section

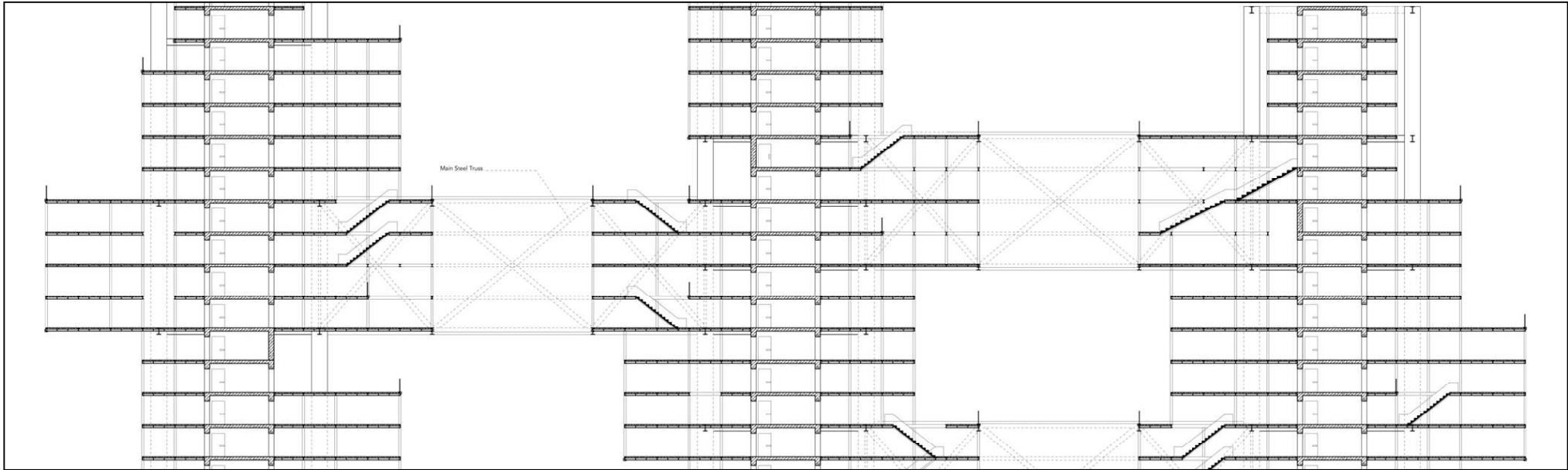

Structural section_Zoom in

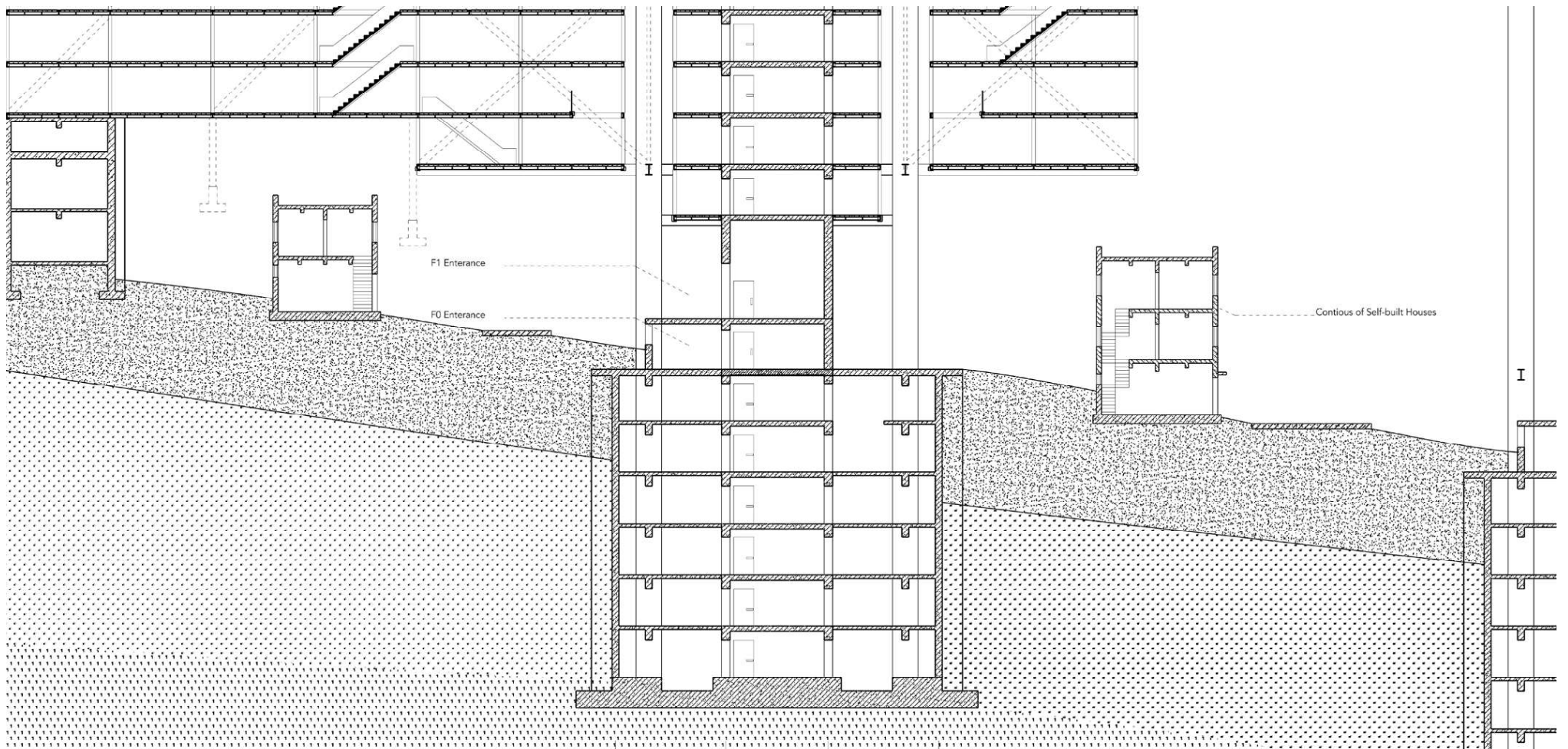

Structural section_Zoom in

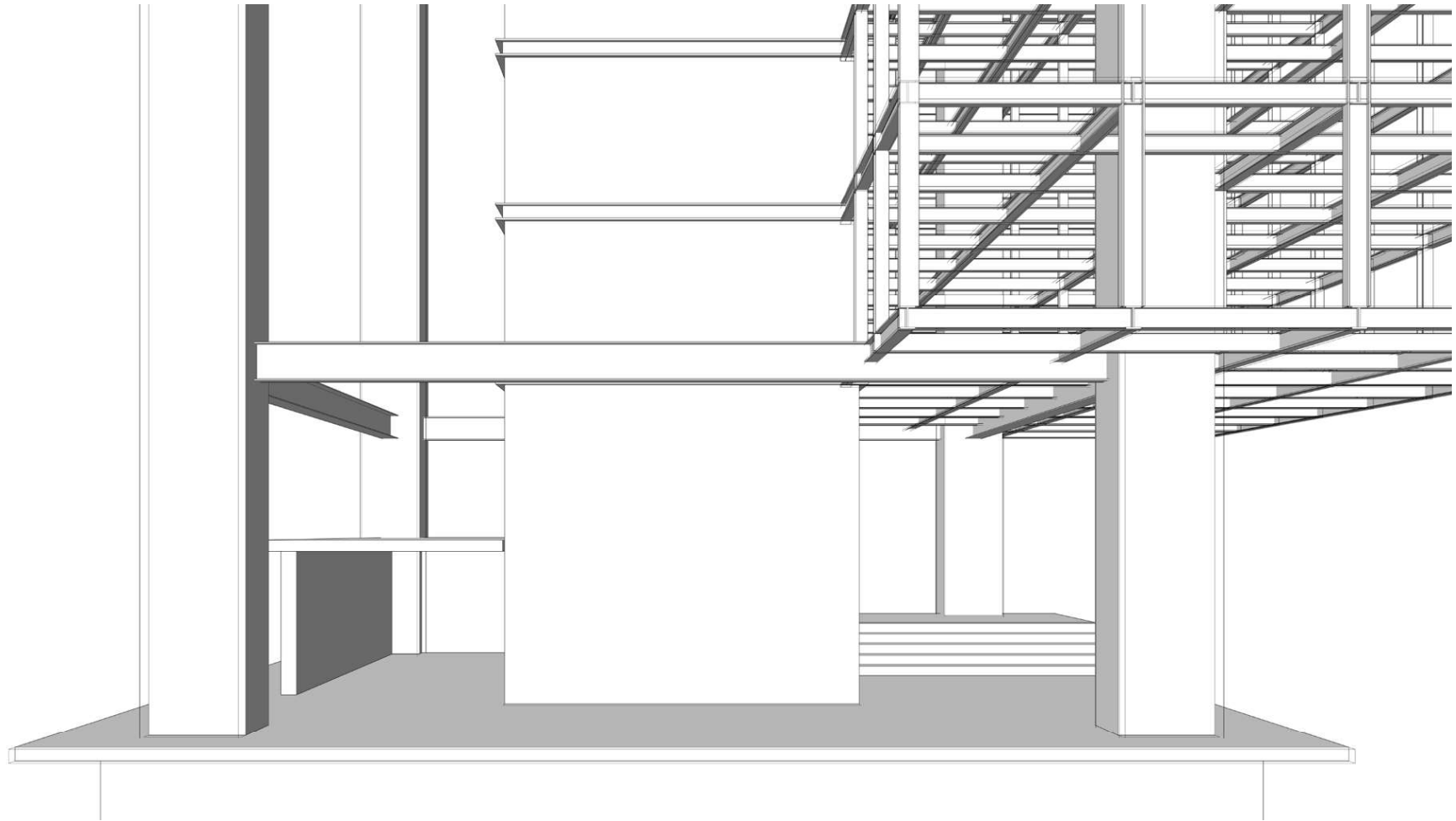

Perspective_Enterance

Street Apartments ←

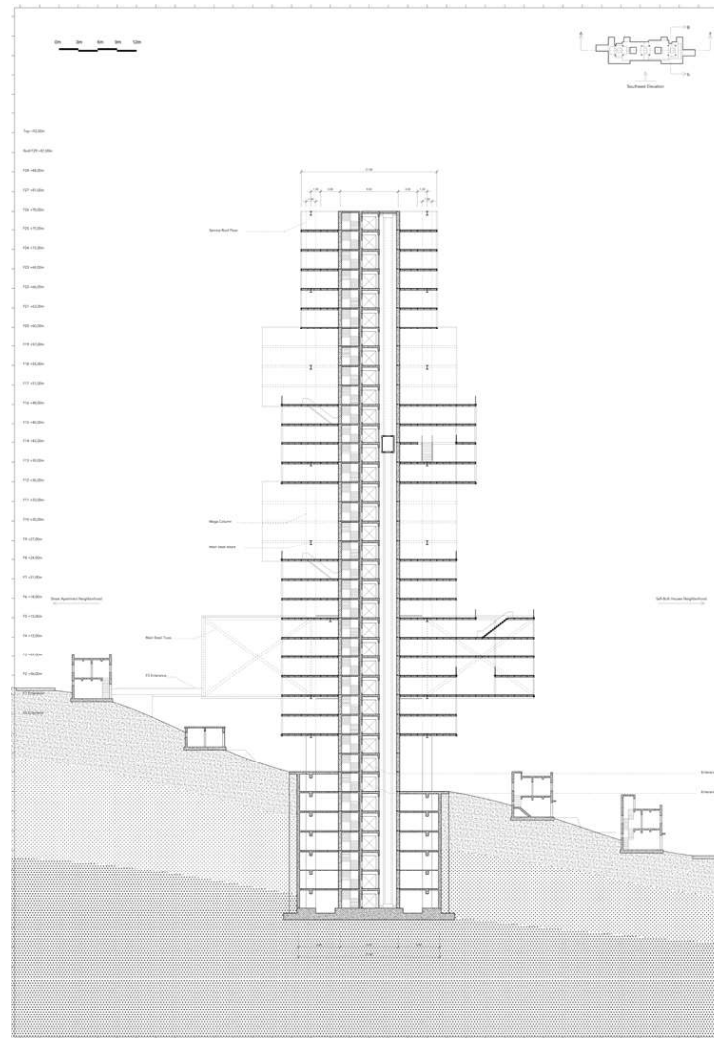

→ Self-builts

Structural section

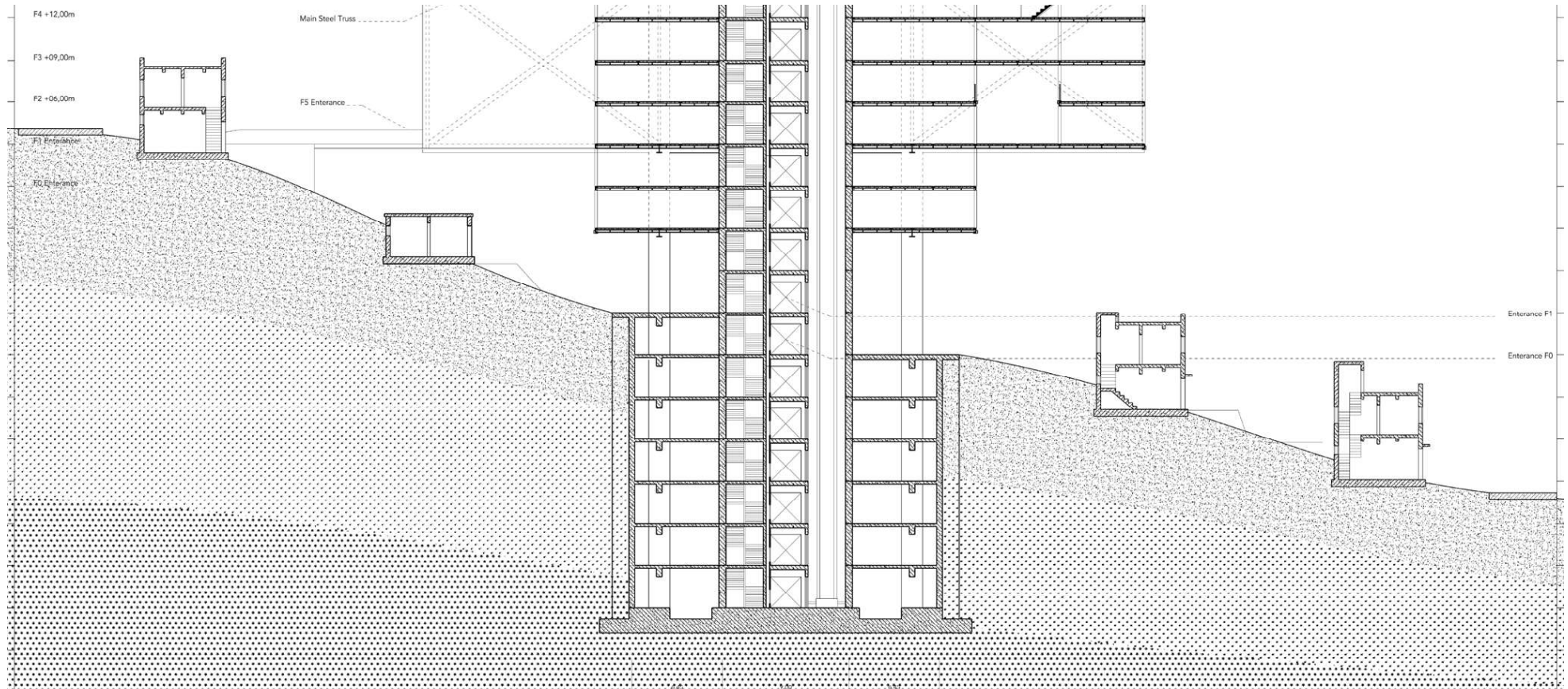

Structural section Zoom in

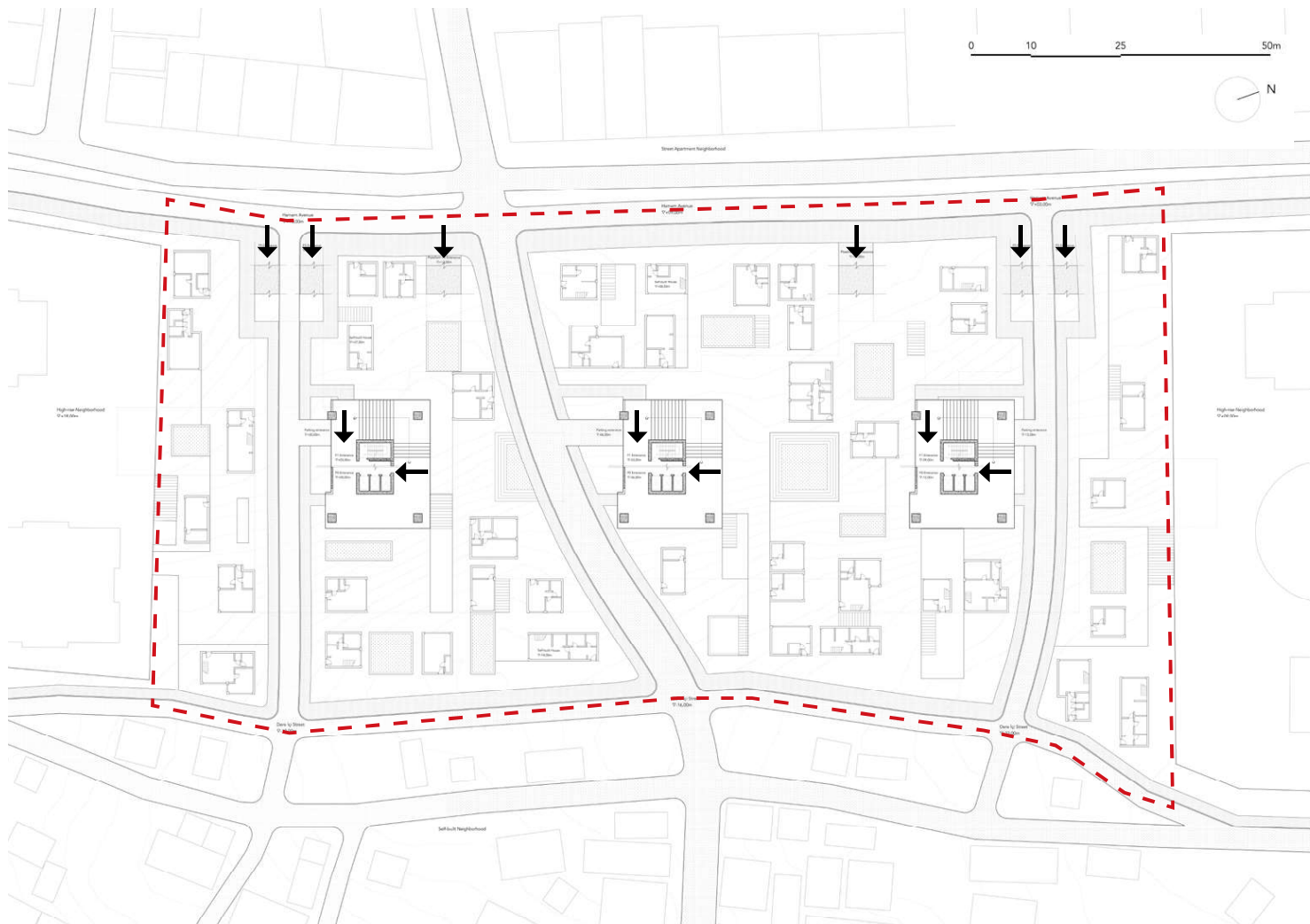

Ground plan

Design Index

- Site area: 15500sqm
- Total floor area: 60800sqm
- Built up area: 3800sqm
- Major building number: 3
- Floor level: 32
- Height: 96m
- Plot ratio: 4,0
- Total residential area: 27043sqm
- Total service area: 23200sqm

- Residential unit number: 457
- Total service unit: 126

- Studio: 54units-36sqm/ 6units-54sqm
- Loft: 24units-90sqm
- Patio: 24units-81sqm/ 12units-108sqm
- Homeoffice: 14units-72sqm/ 14units-108sqm
- Hotel apartment: 24units-18sqm/ 40units-27sqm
- 1-bedroom flat: 100units-54sqm/ 56units-64sqm
- 2-bedroom flat: 54units-81sqm
- 3-bedroom flat: 24units-108sqm/ 20units-135sqm

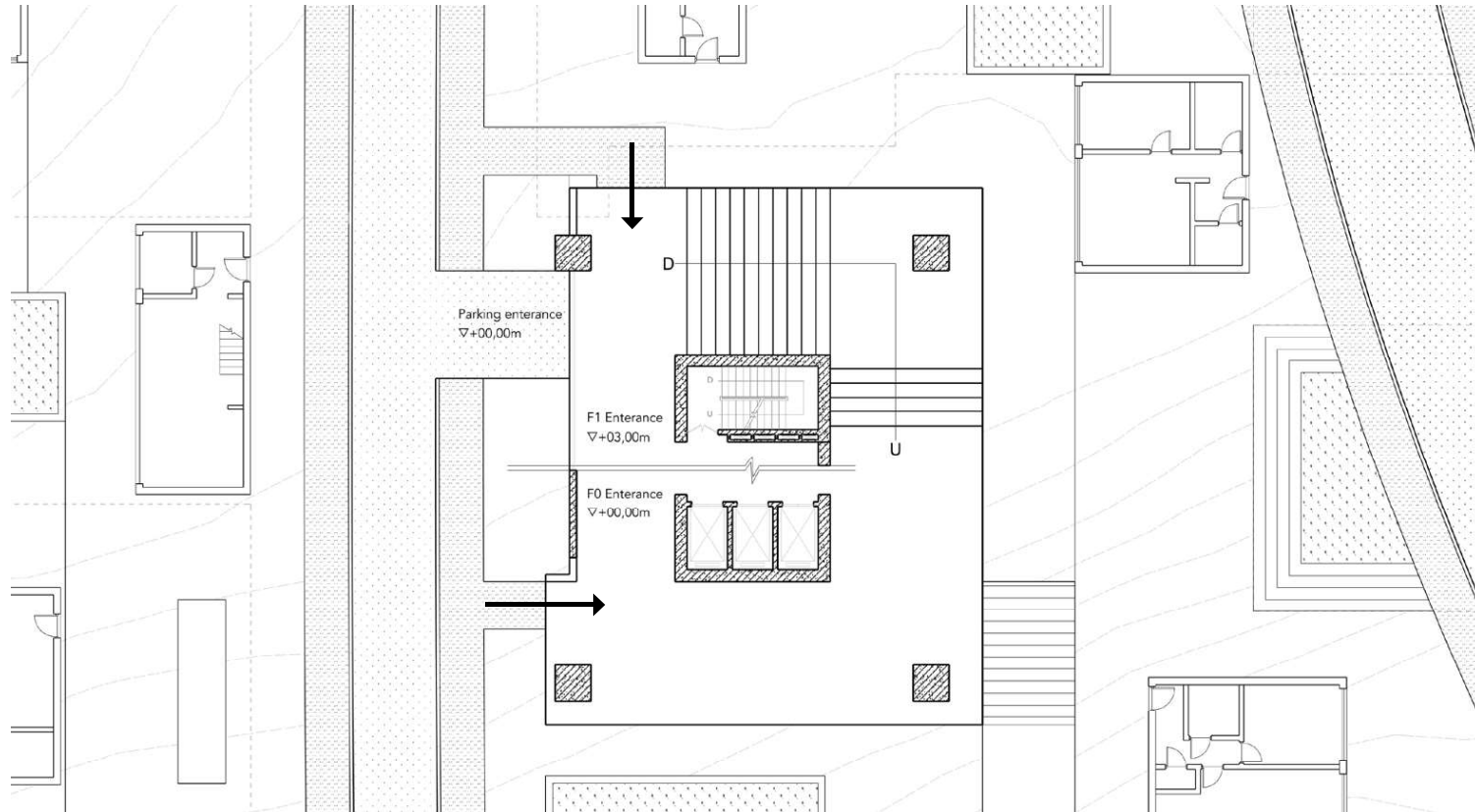

Ground Plan__Zoom in

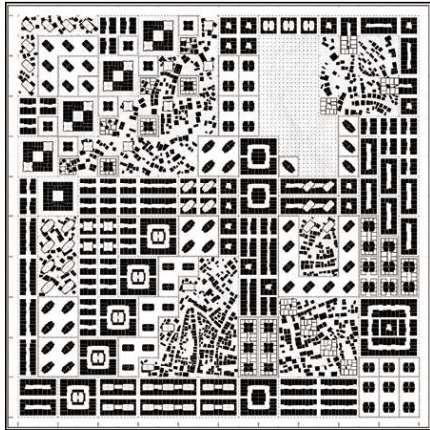

URBAN
1000M

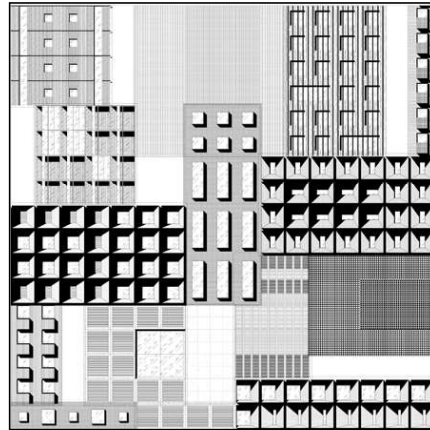

ARCITECTURAL
50M

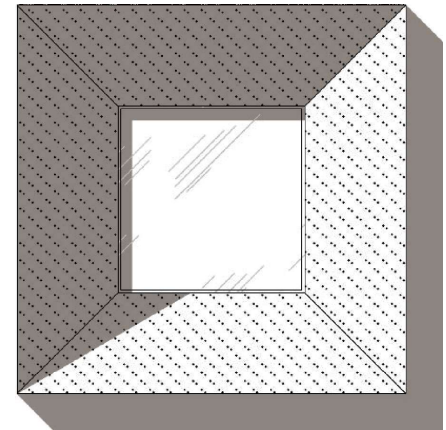

FACADE&INTERIOR
3M

Experiment IV__Facade patterning

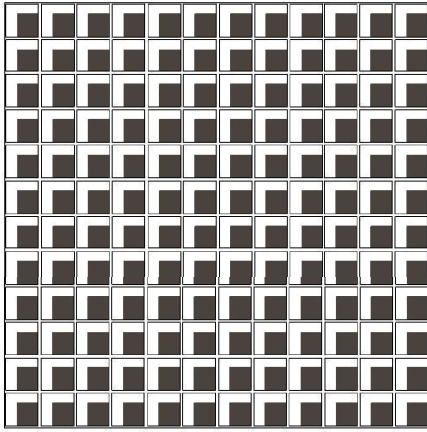

Enclosed-Flat

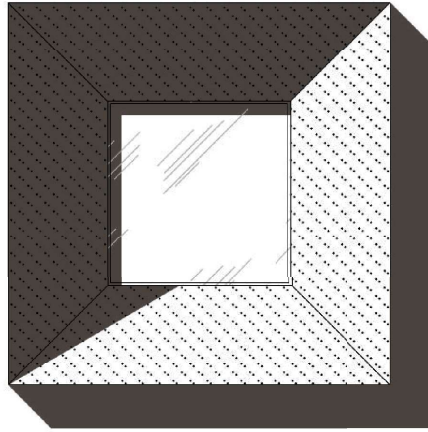

Sculptural

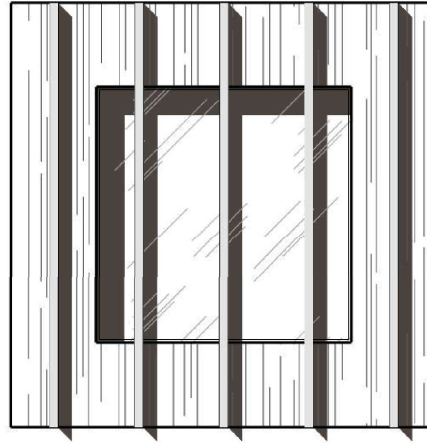

Sculptural-Flat

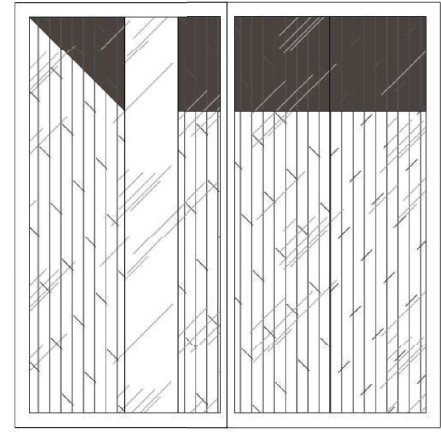

Open-Flat

Experiment IV__Prototypes

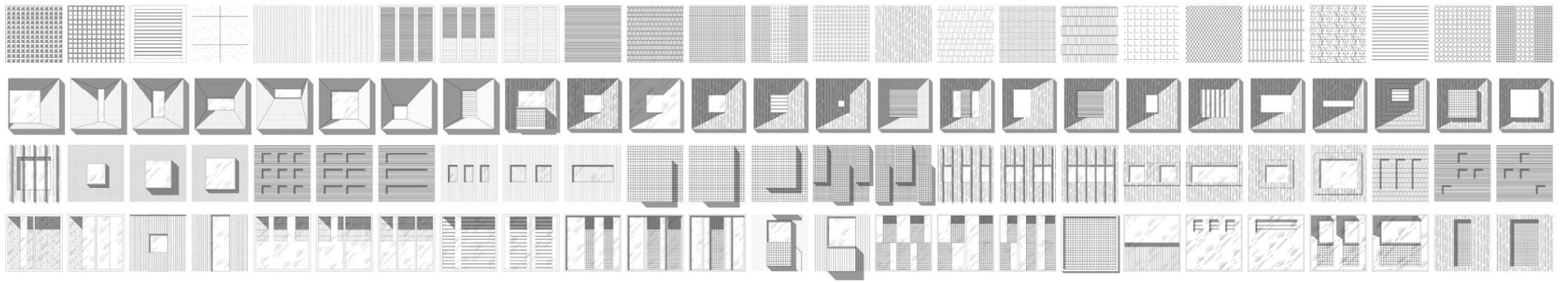

Experiment IV__Toolbox

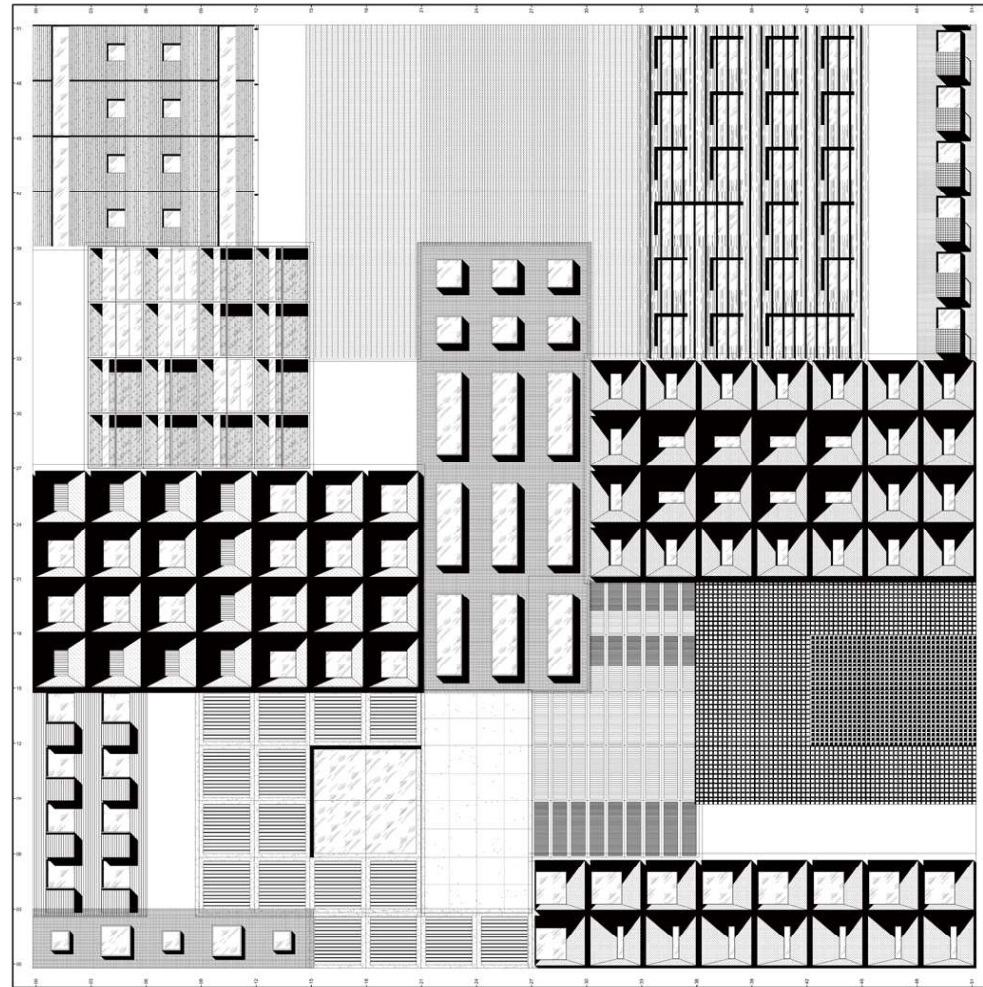

Experiment IV__Facade pattering

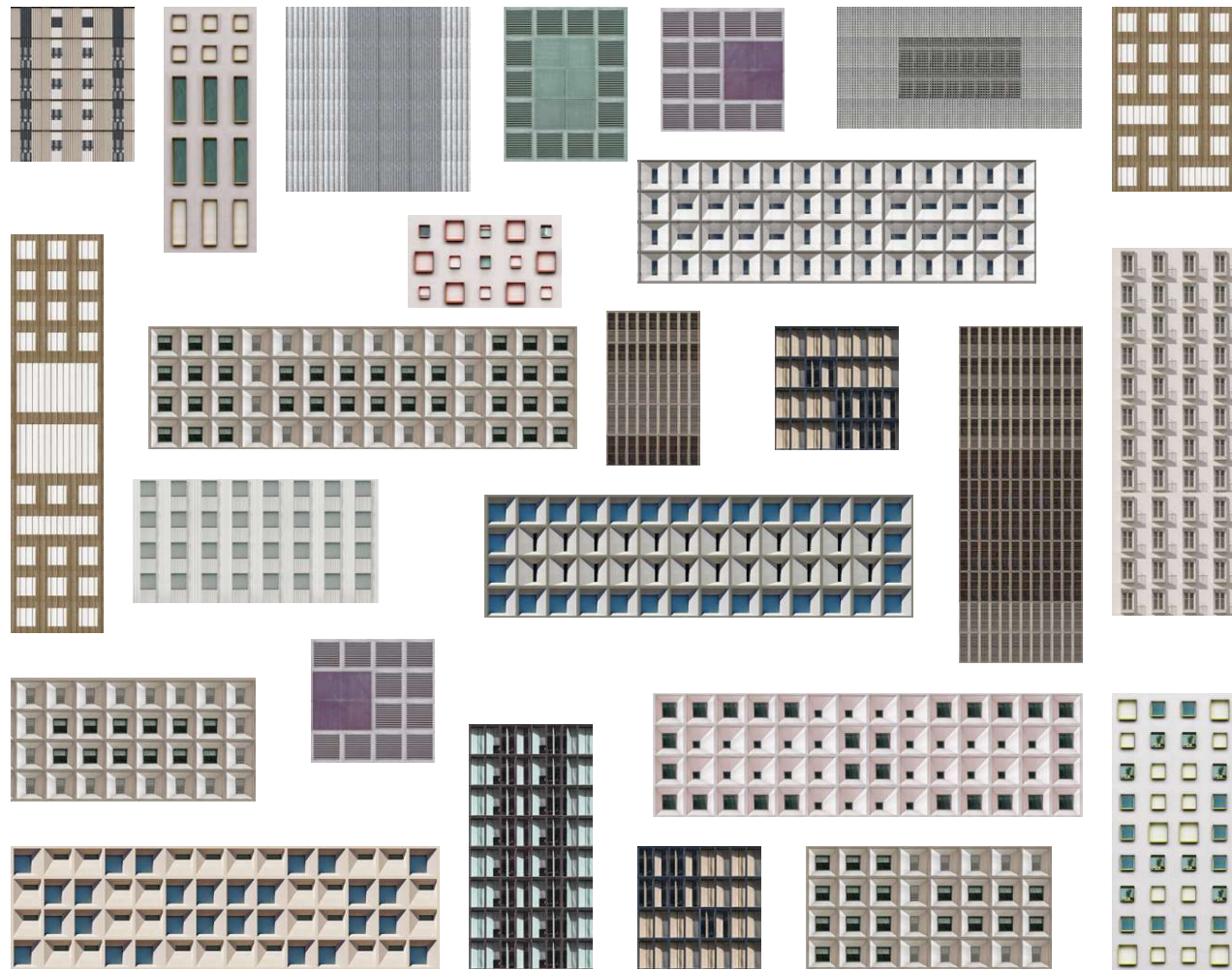

Experiment IV__Facade patterning

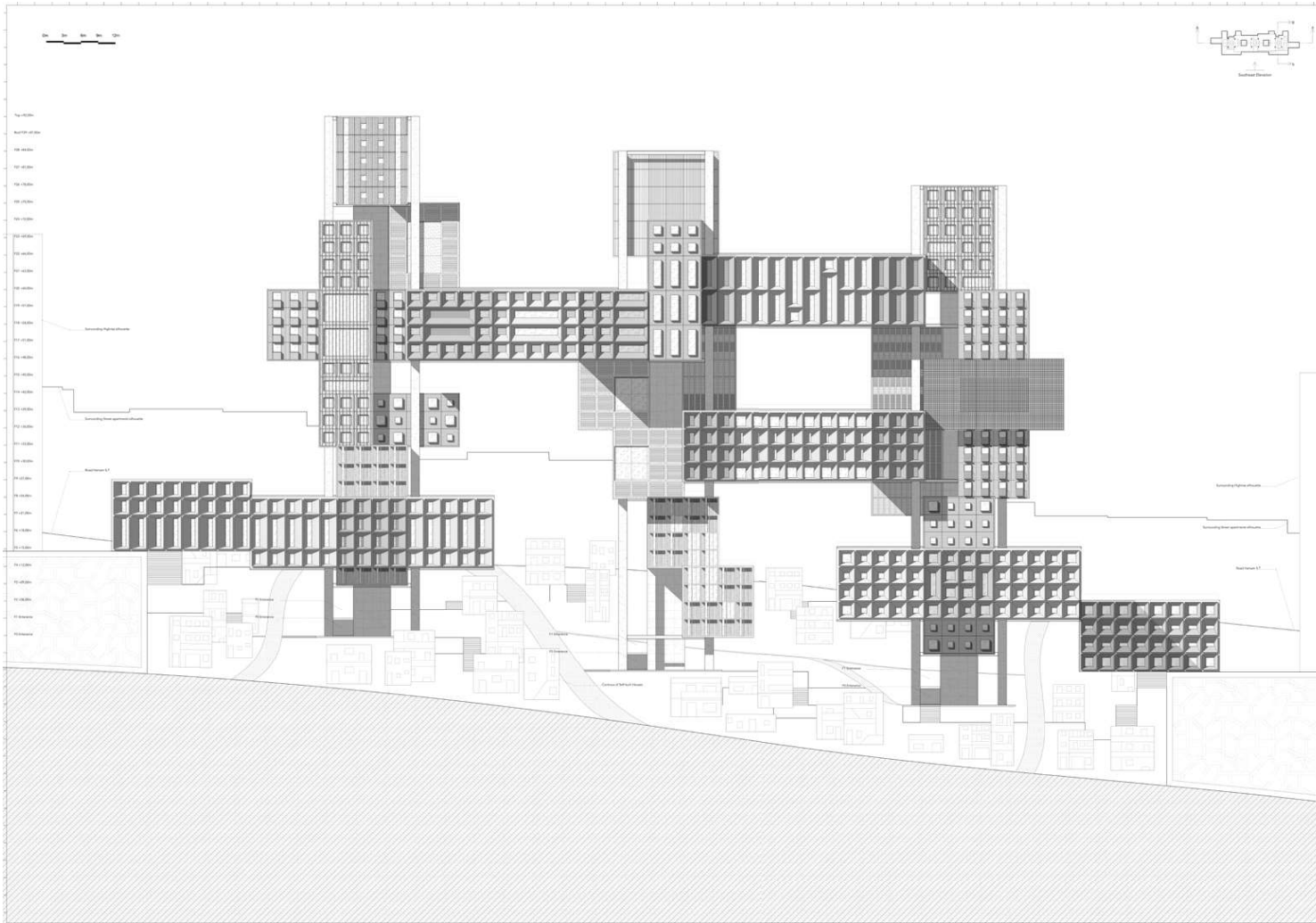

Experiment IV__Eelvation

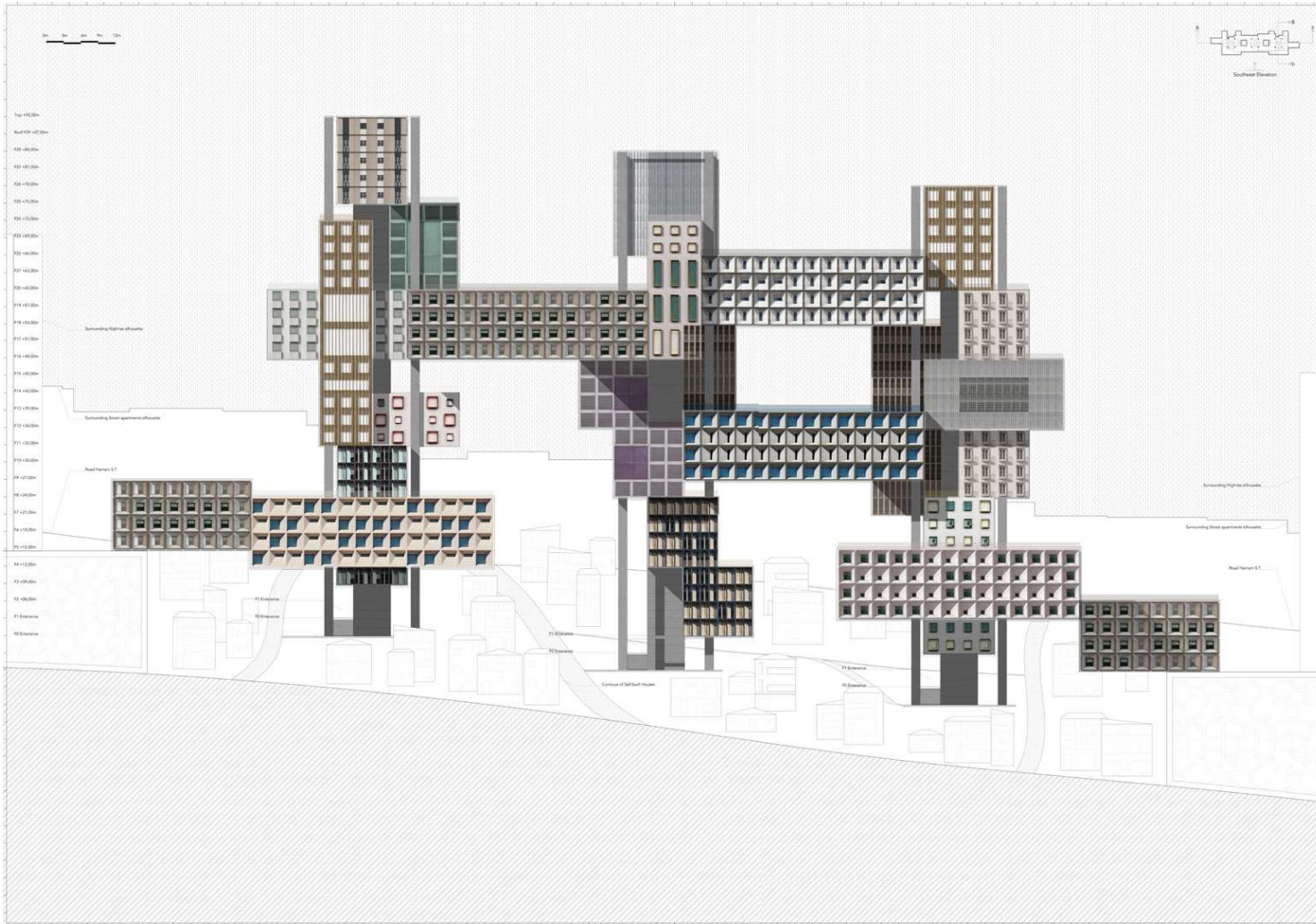

Experiment IV__Eelvation

Floor area
3681sqm

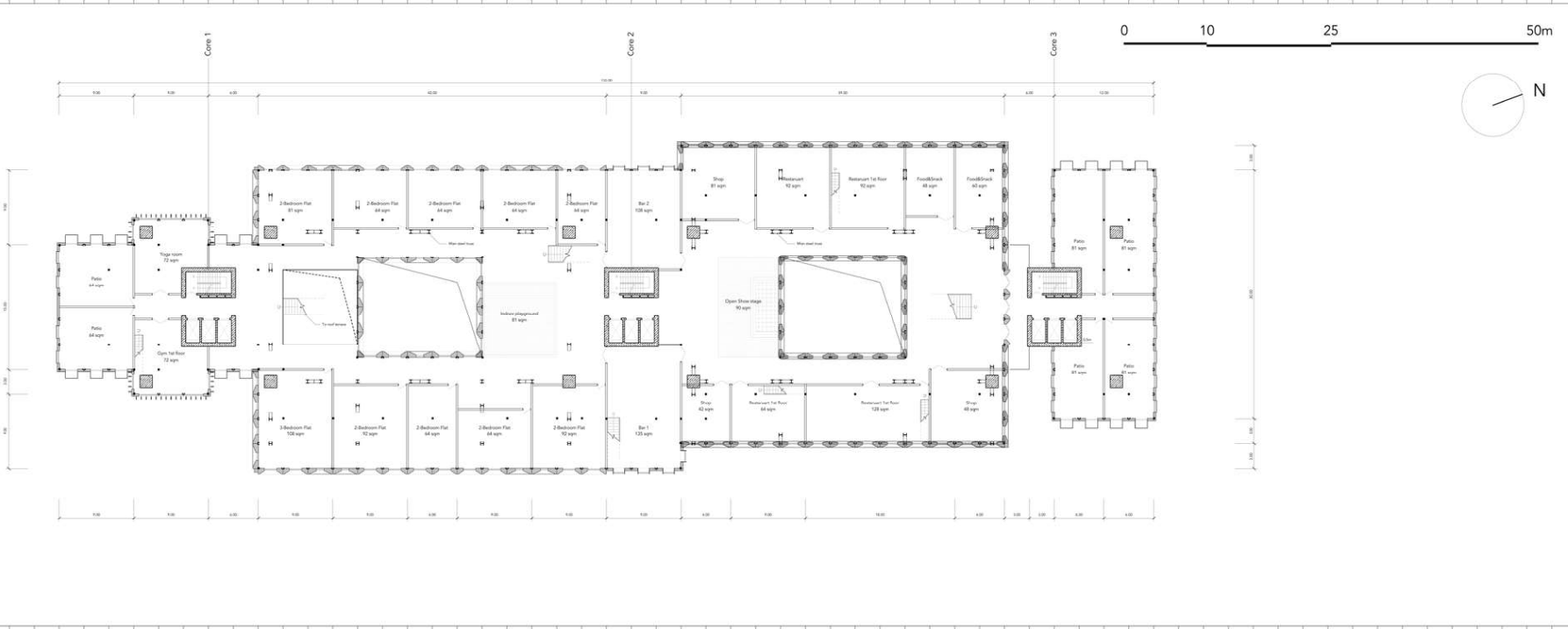

Floor Plan 18th

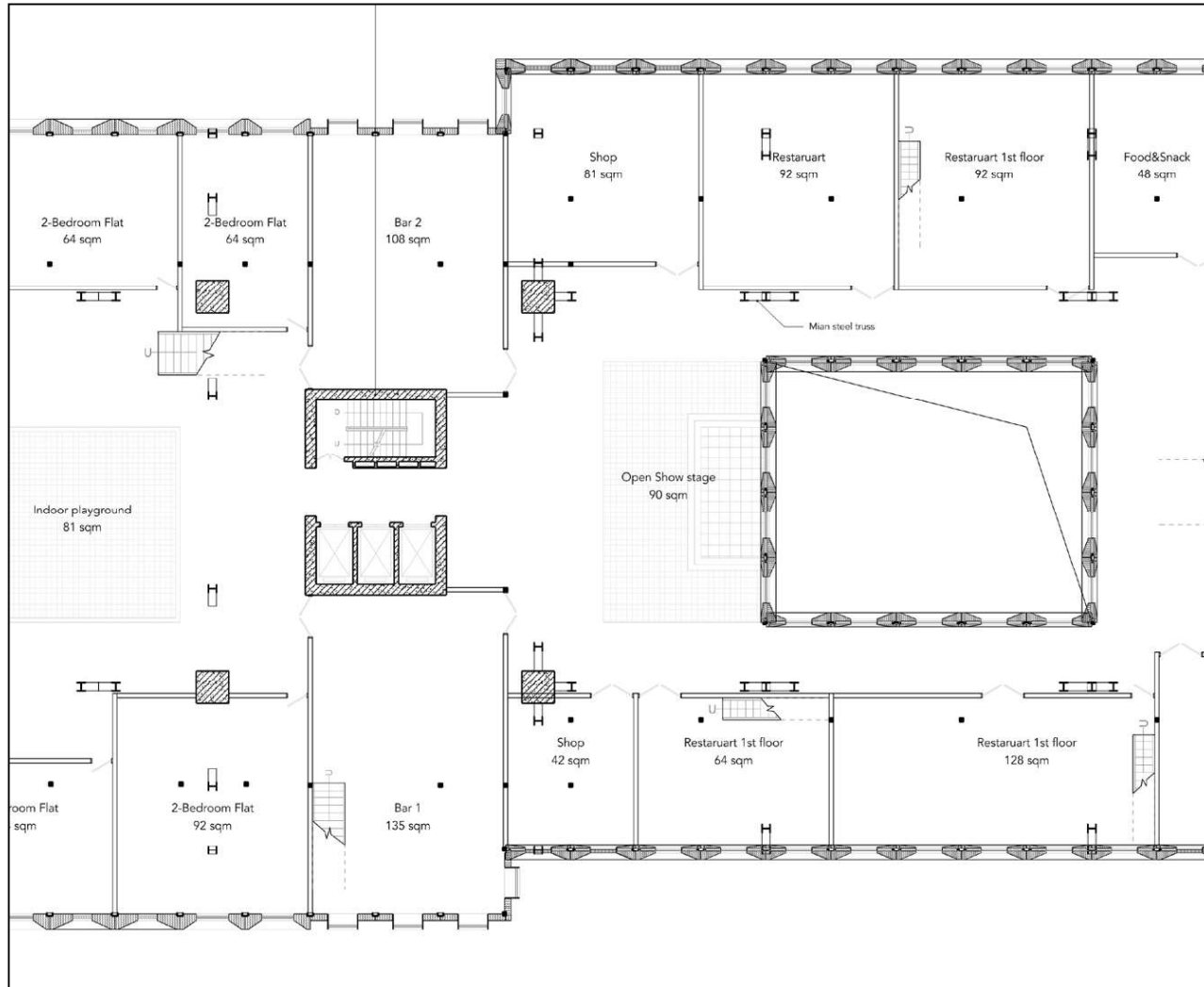

Floor Plan 18th_Zoom in

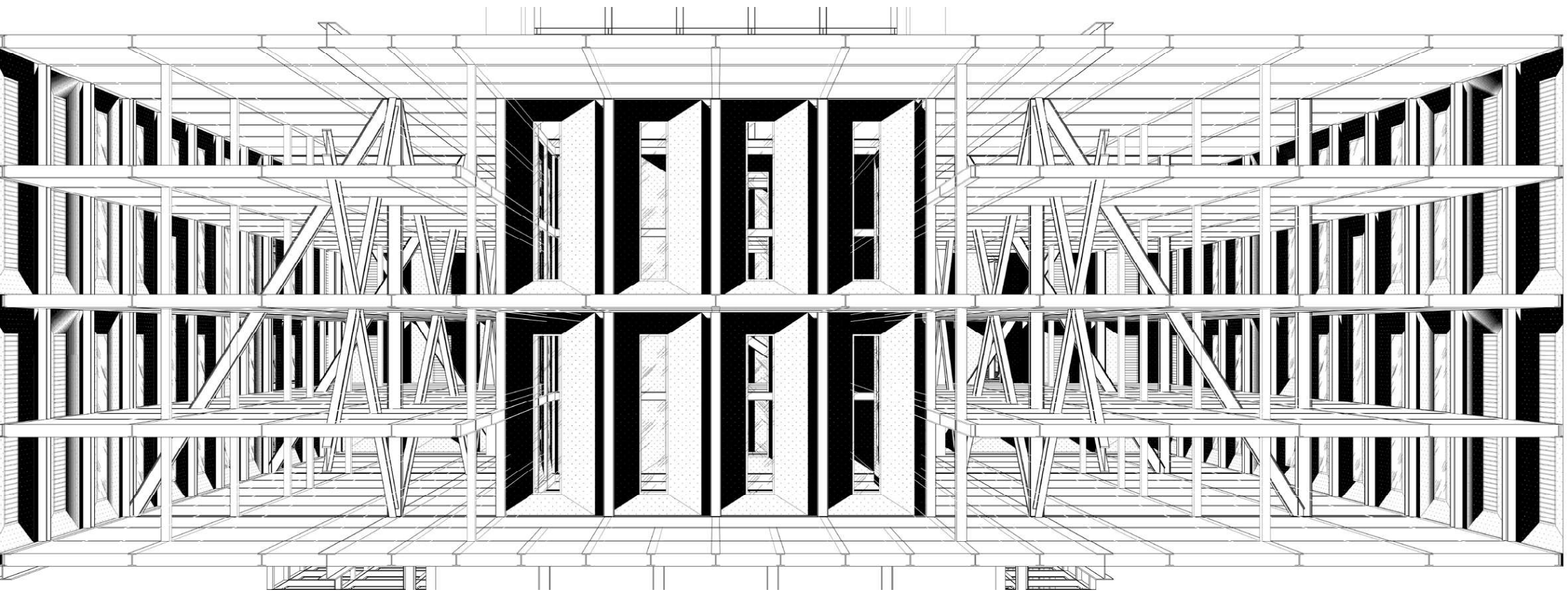

Perspective_collective space

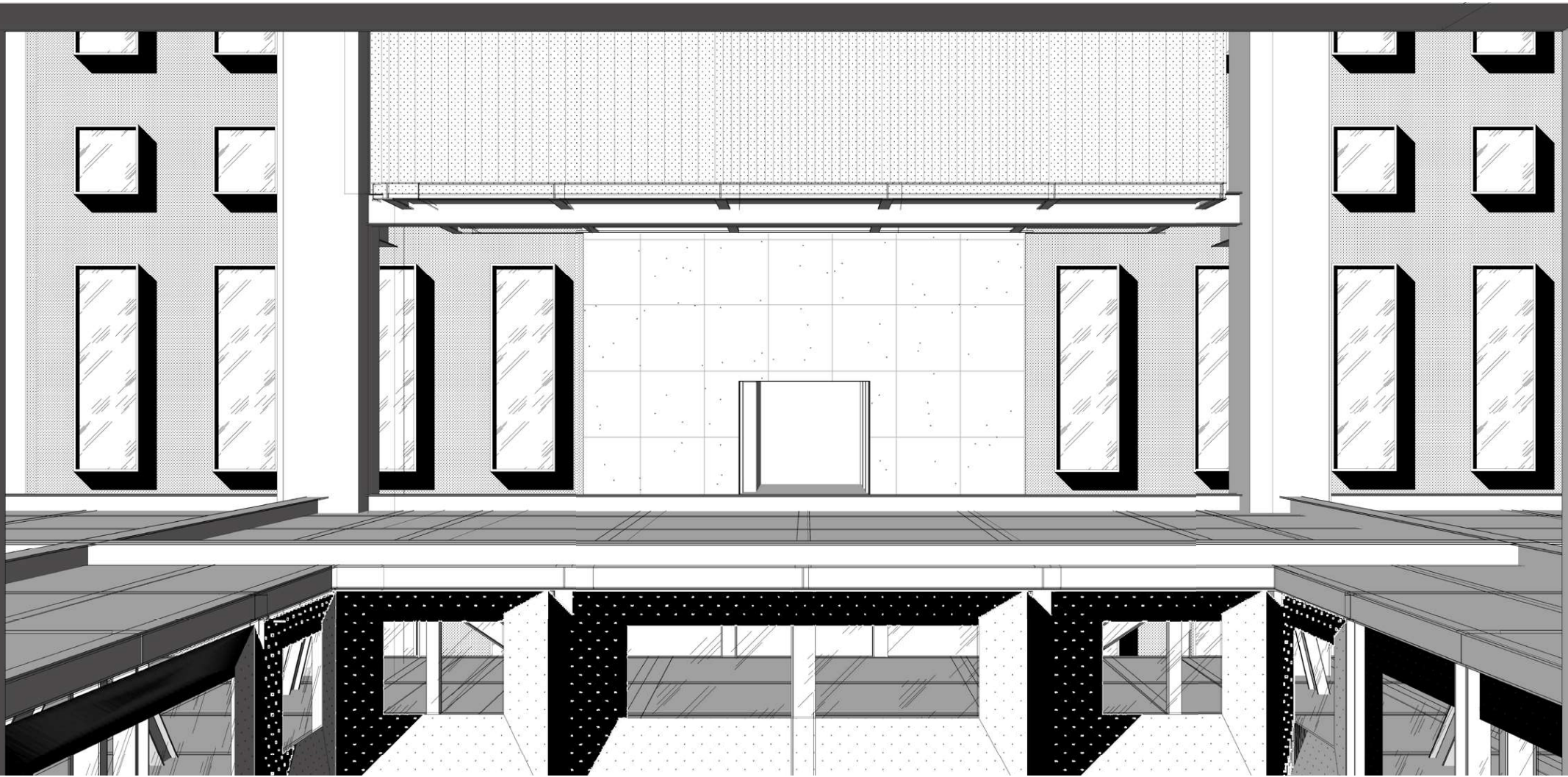

Perspective_Roof terrace

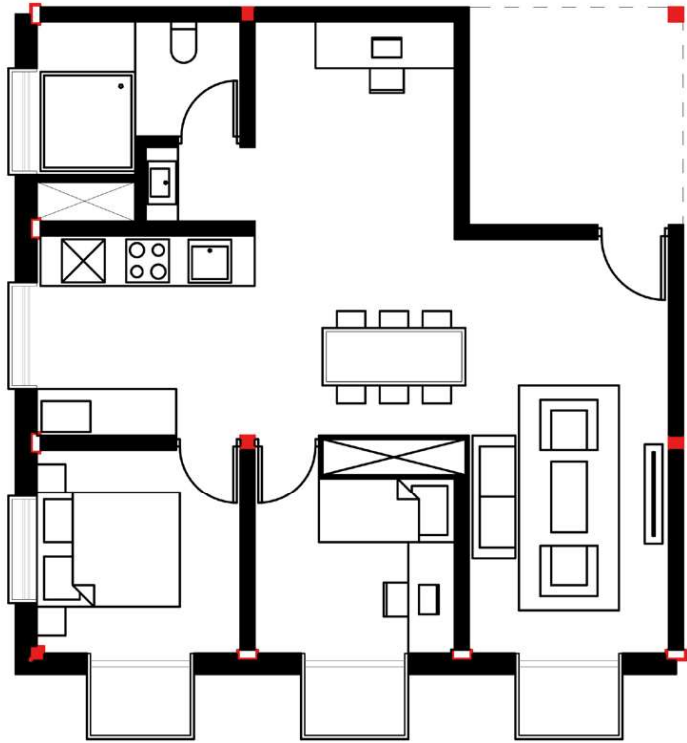

Patio 72sqm

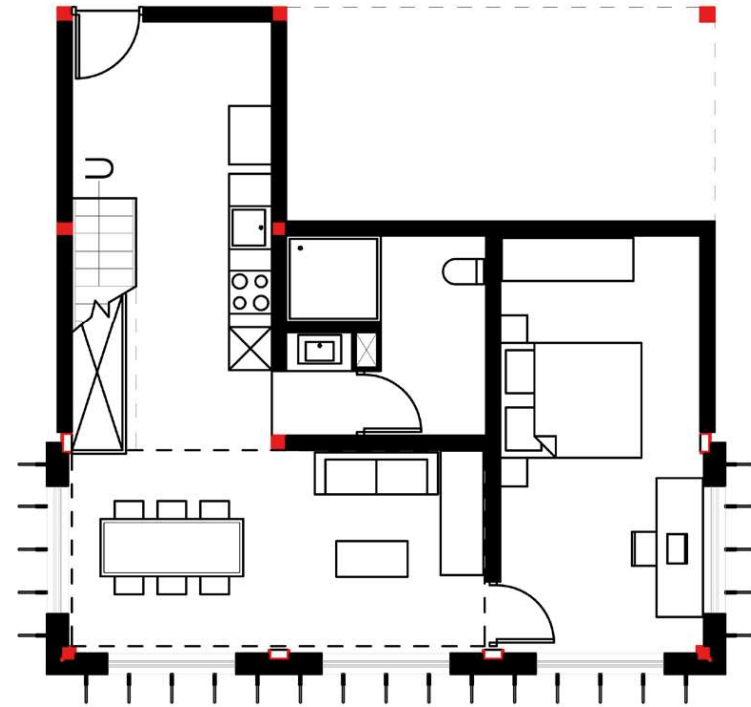

Loft 63+45sqm

Interior Plan_Variations

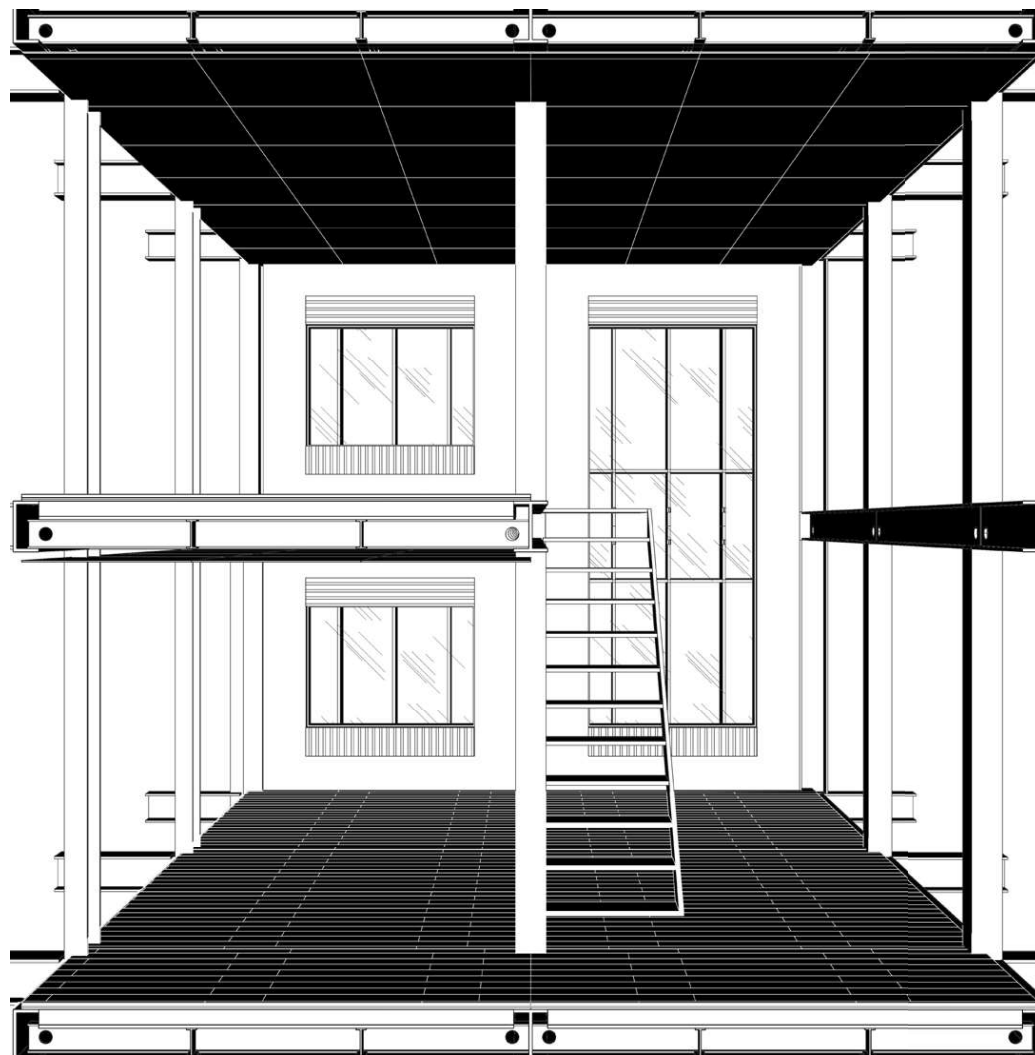

Interior Plan_Air/Water/Electric

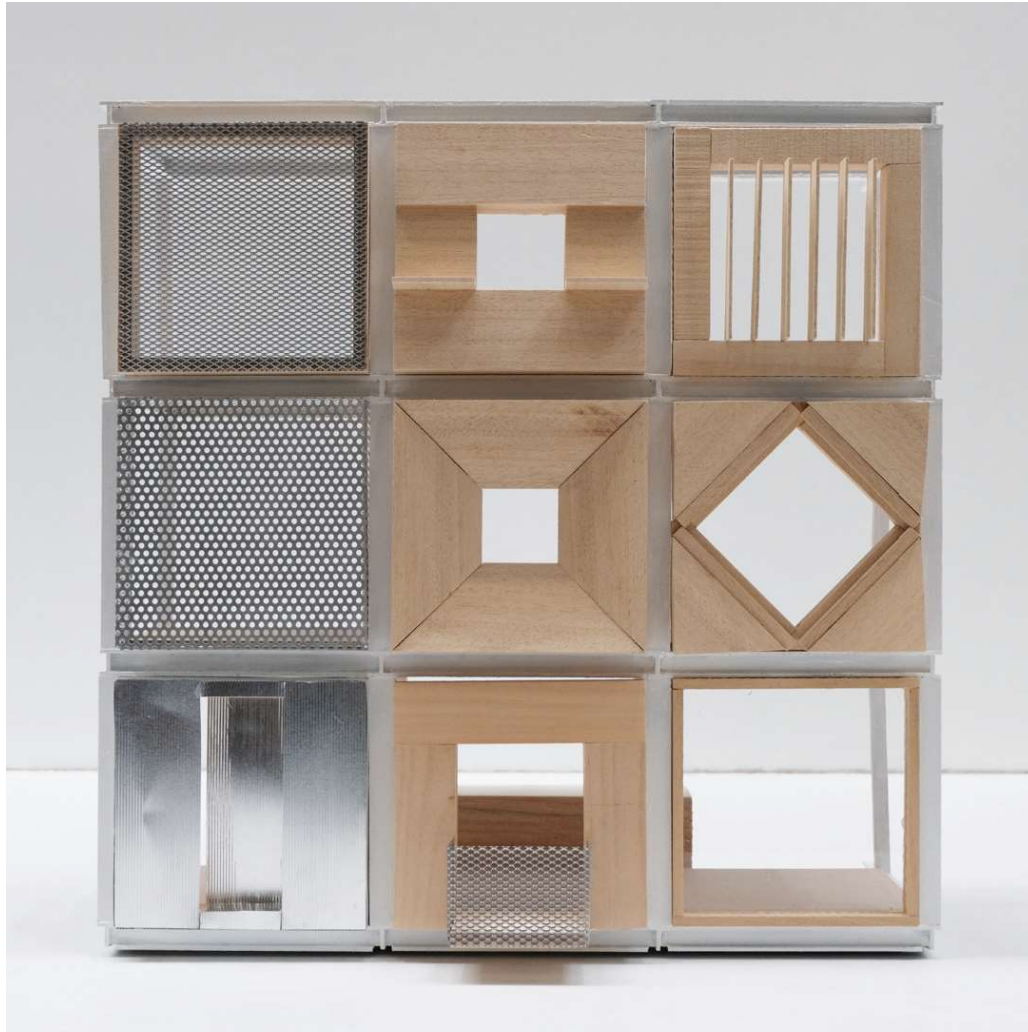

Corner model__Facade

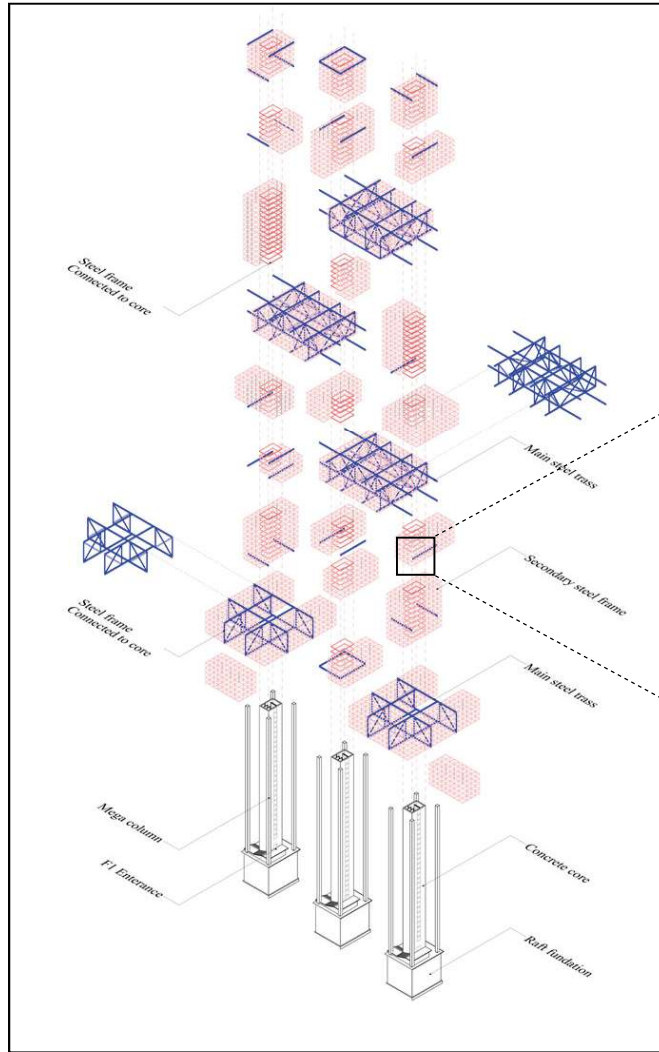

General structure

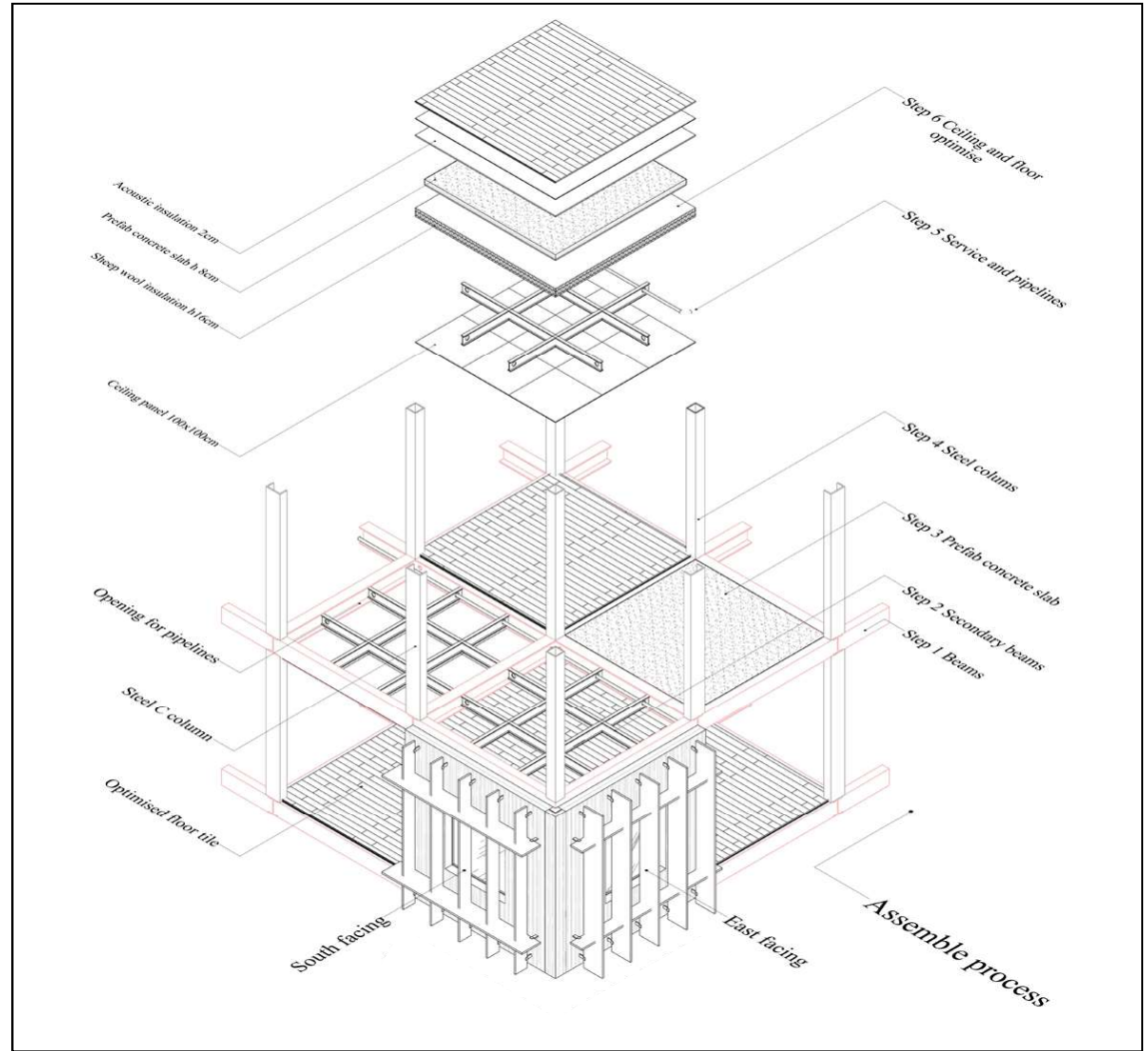

Detailed structure

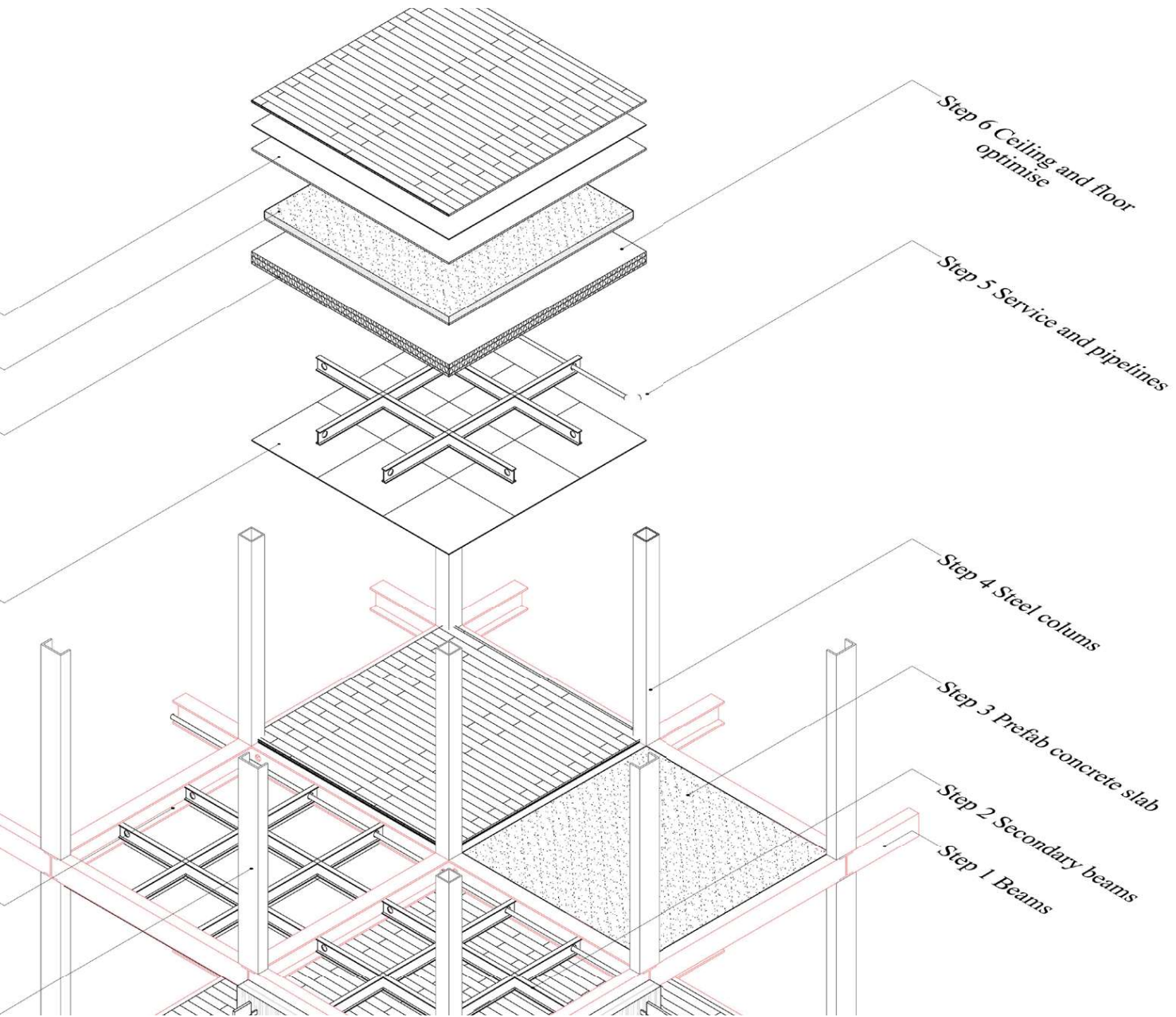

Assemble/Circulity

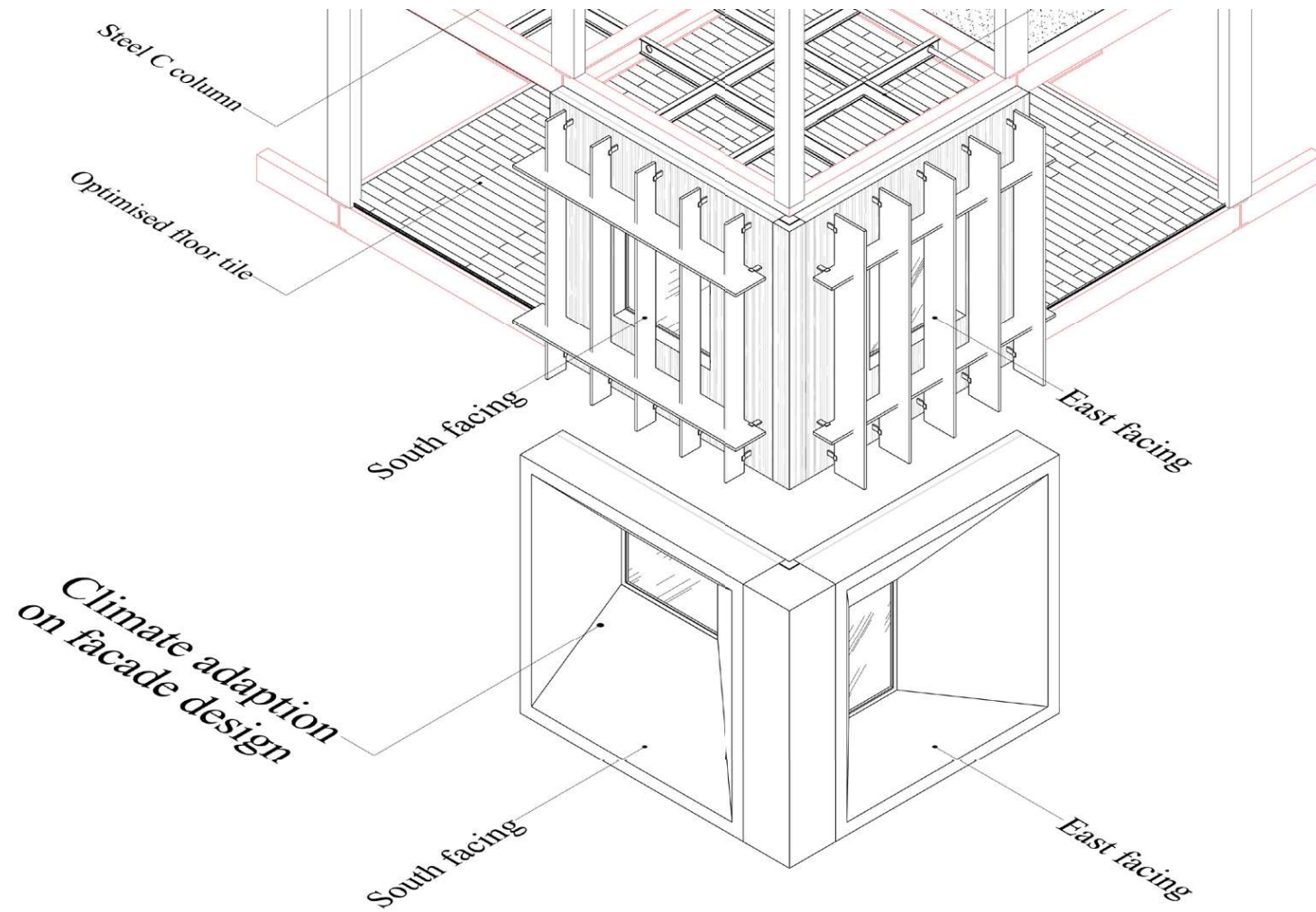

Corner model__Facade/Climate

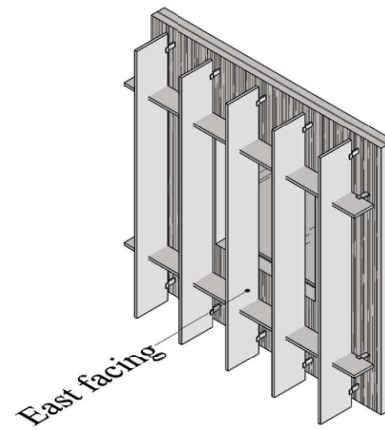
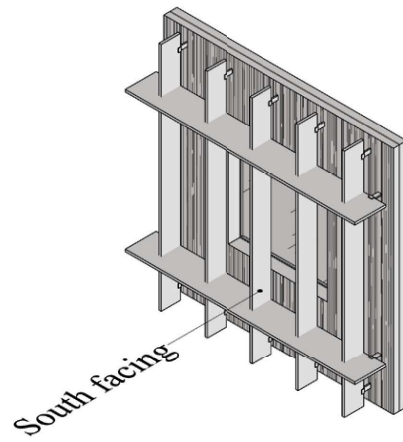
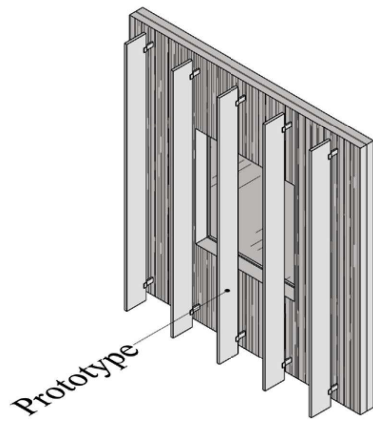
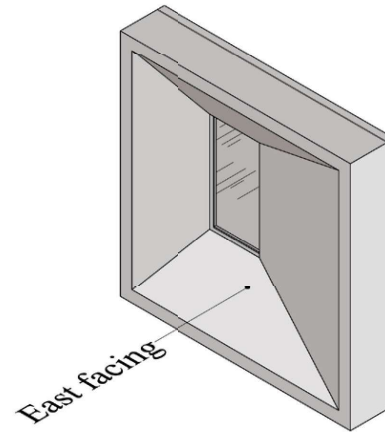
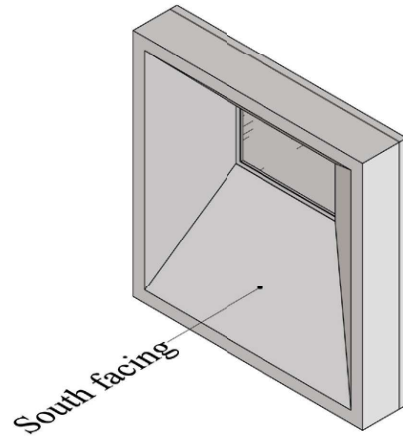
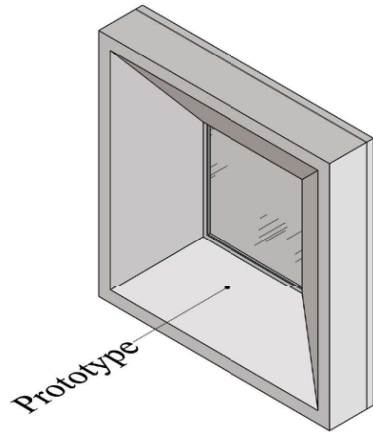

Corner model__Facade/Climate

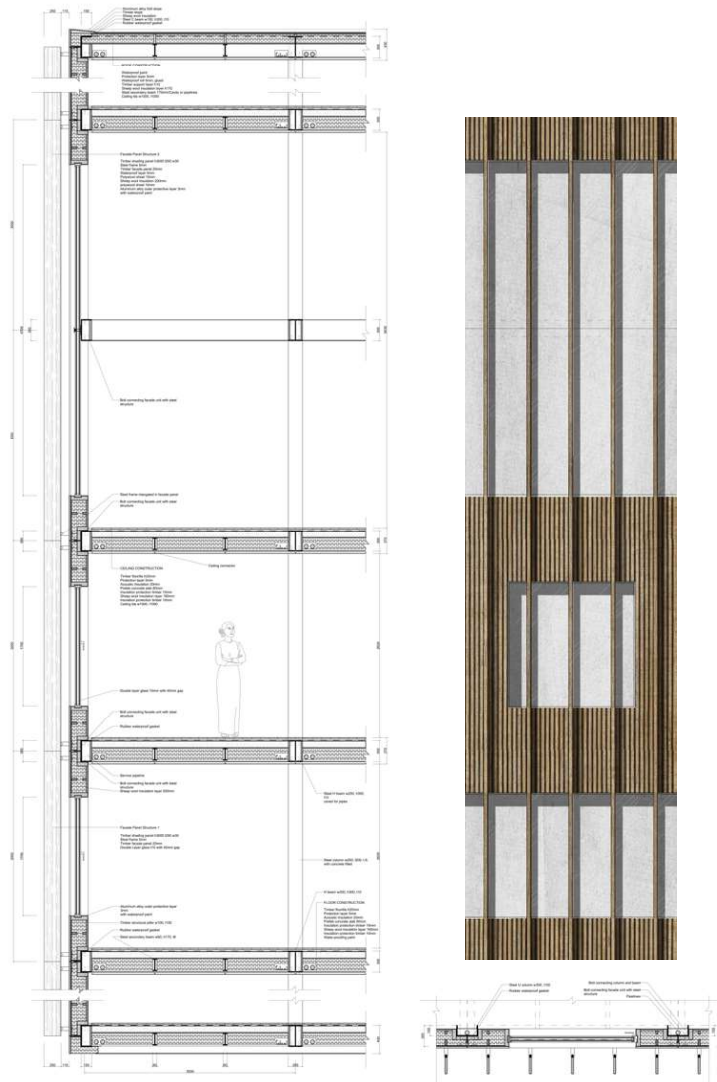

Detailed Section__Facade/Climate

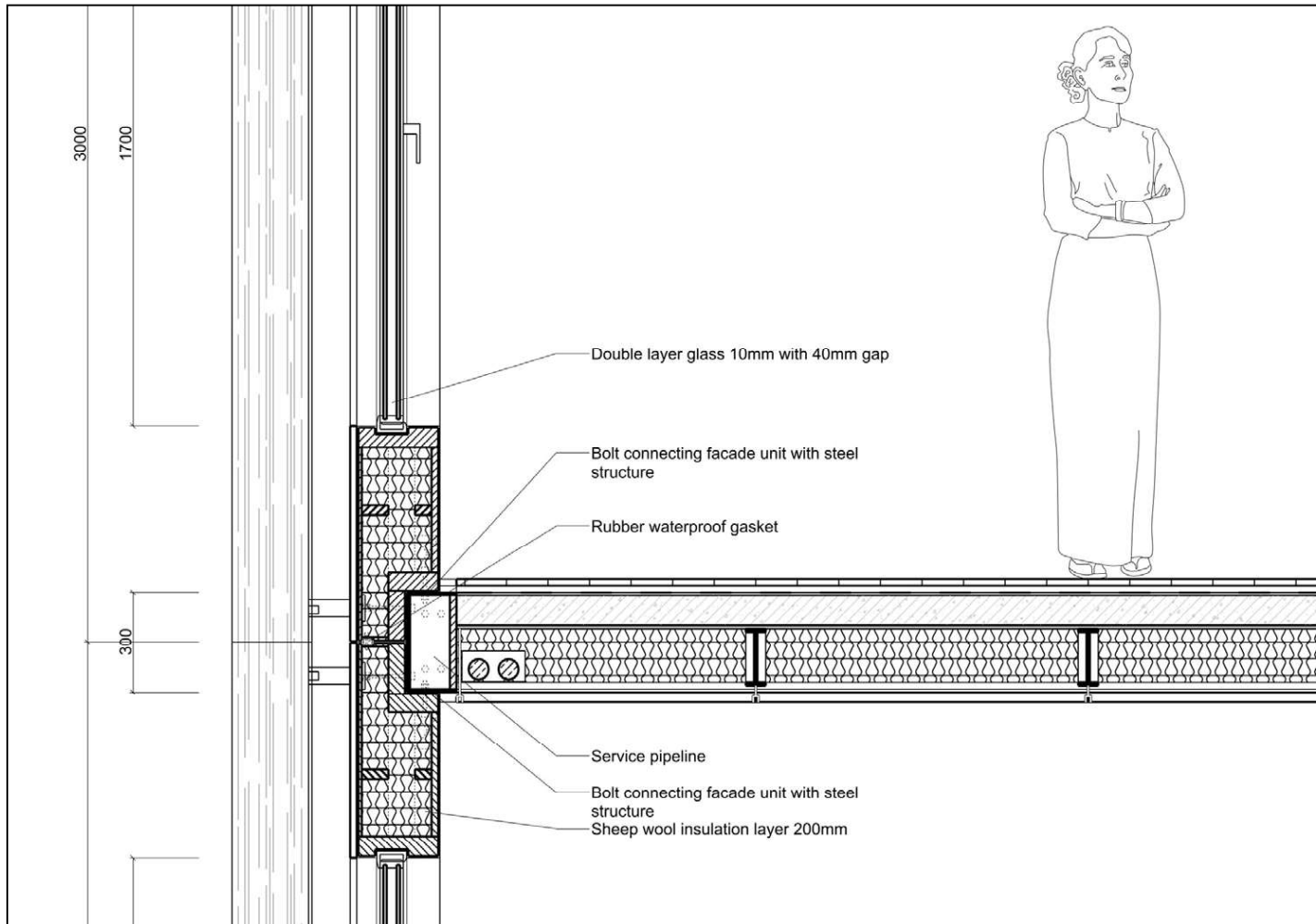

Detailed Section__Facade/Climate

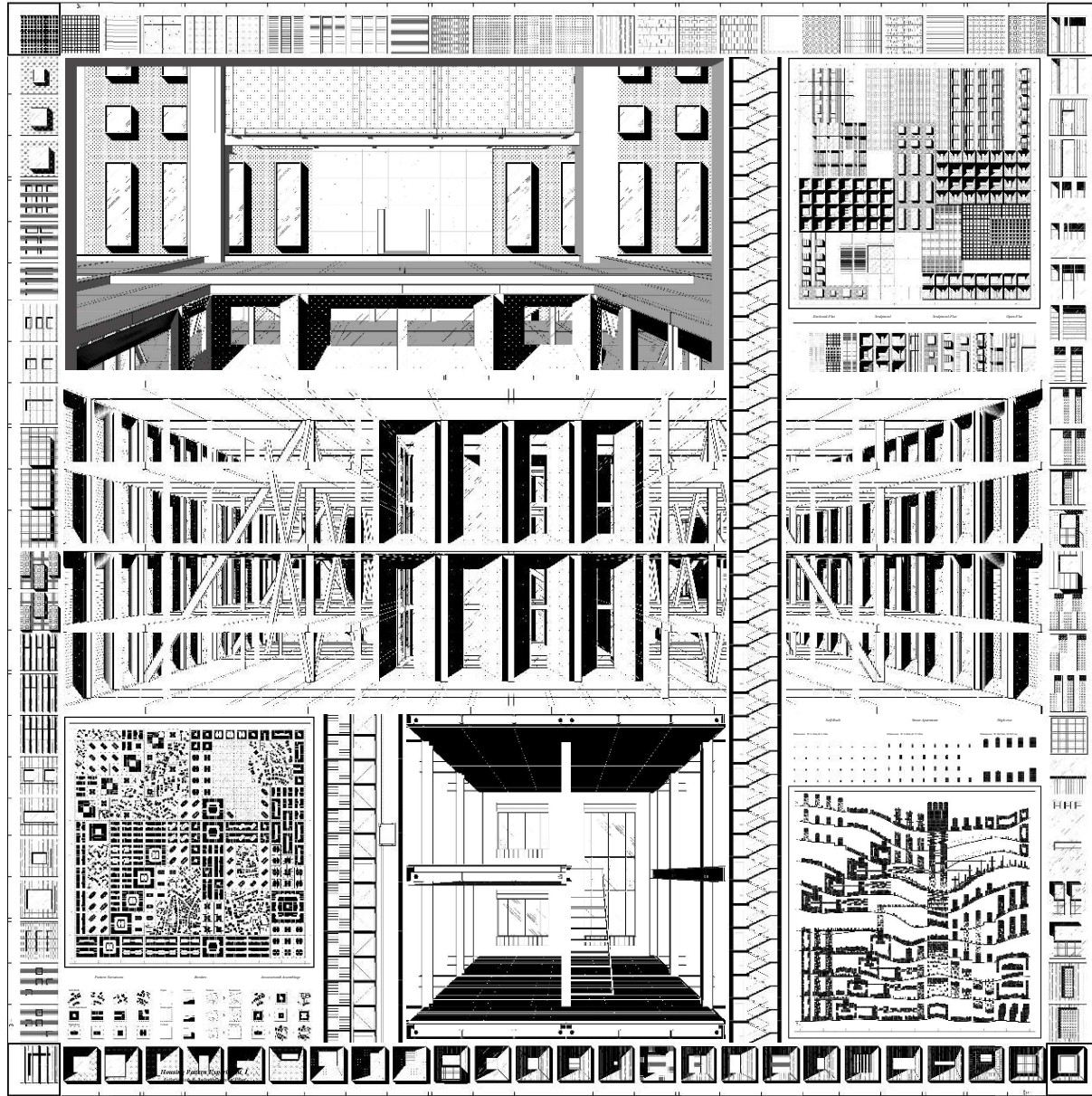

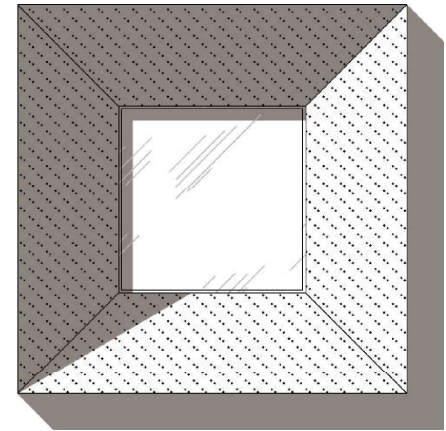
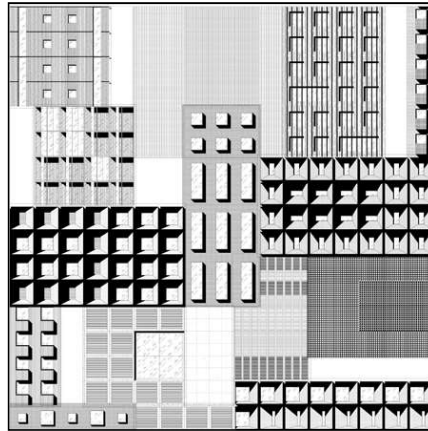
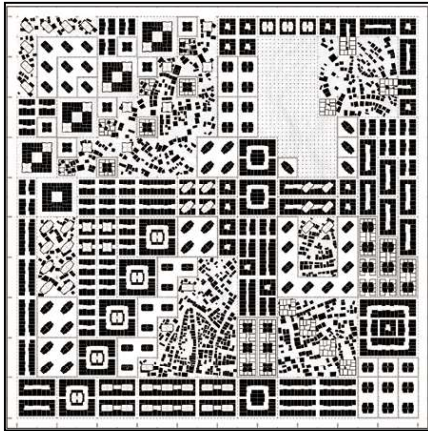

Associations & Assemblages
A Pattern-based Housing Group Form in Istanbul