

The Circular Cornerstone

Facade



The Circular Cornerstone

Apartment Interior



The Circular Cornerstone

Atrium Interior



The Circular Cornerstone

Exhibitor Space



Circle Construction

Phase 01: Adding the Loadbearing Structure

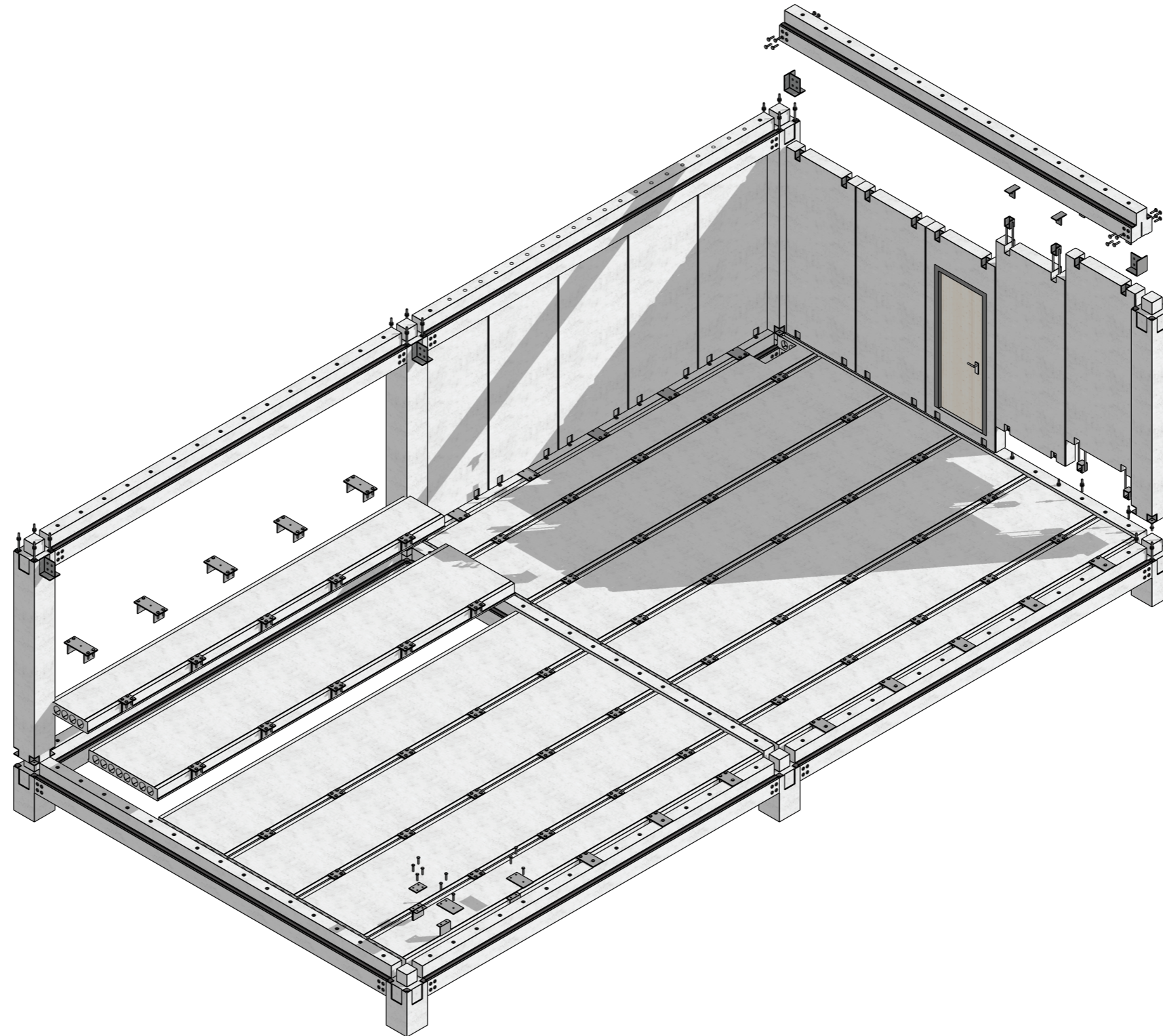

Circle Construction

Phase 02: Adding the Floor Structure.

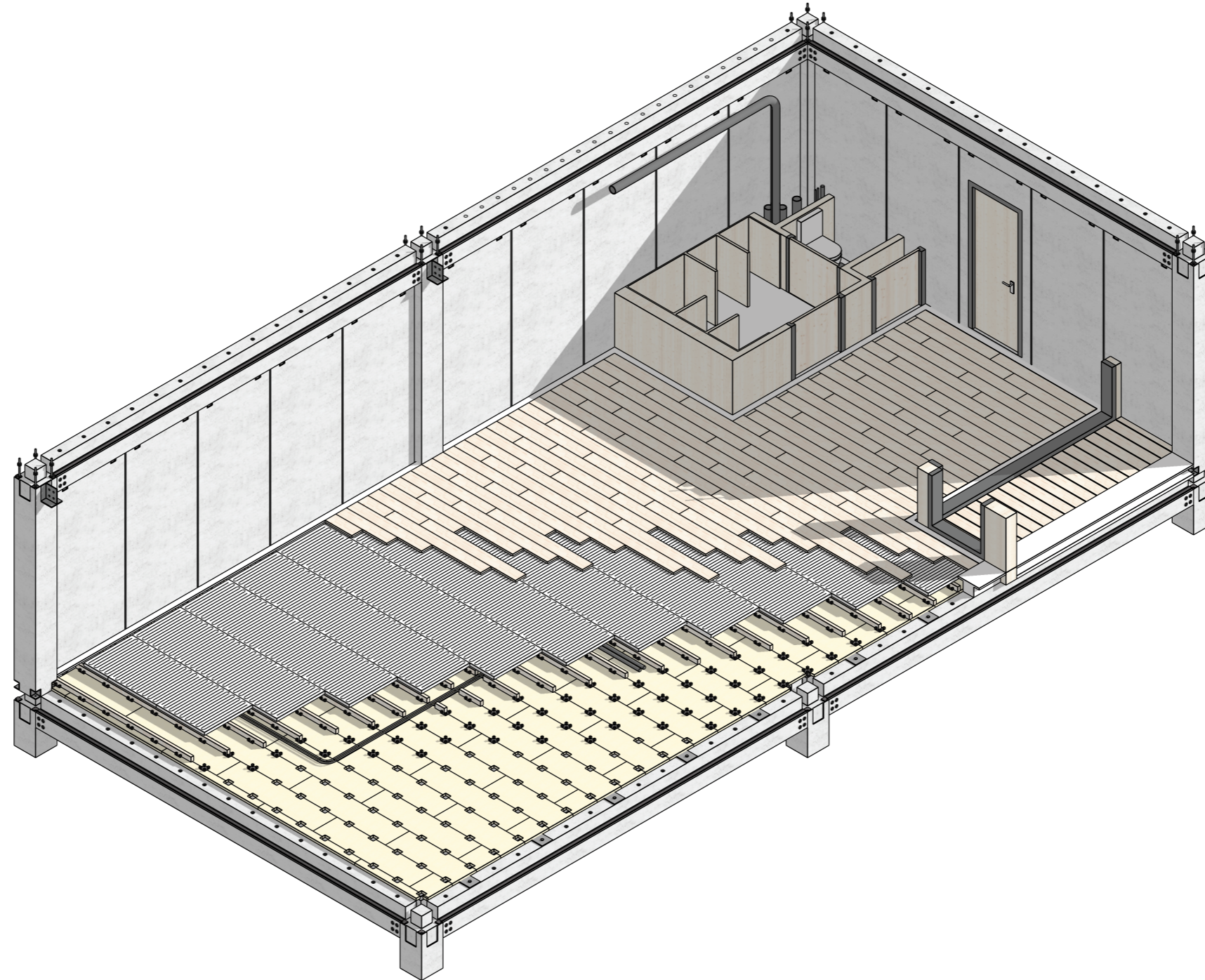

Circle Construction

Phase 03: Adding the Interior.

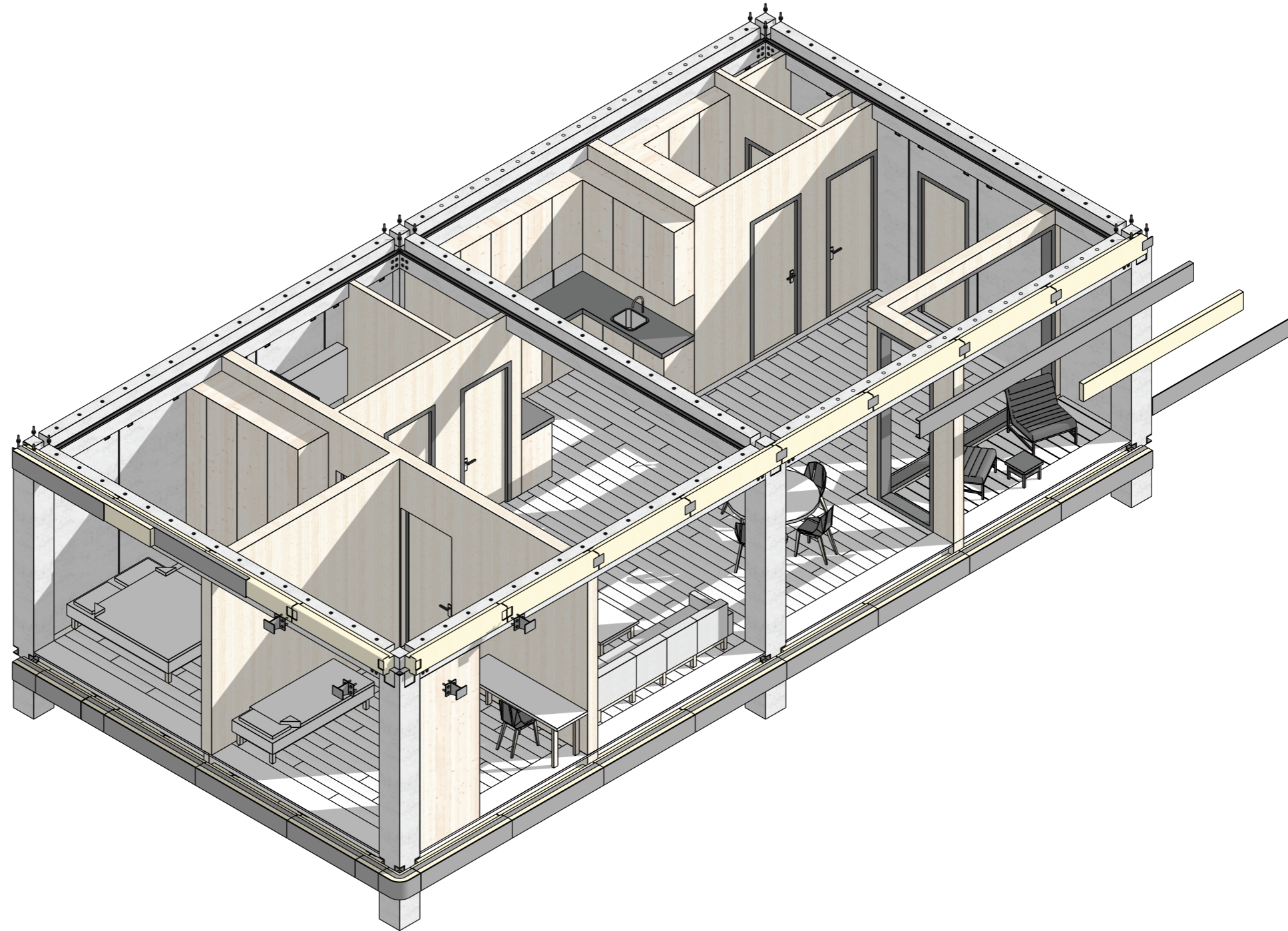

Circle Construction

Phase 04: Adding the Facade Elements.

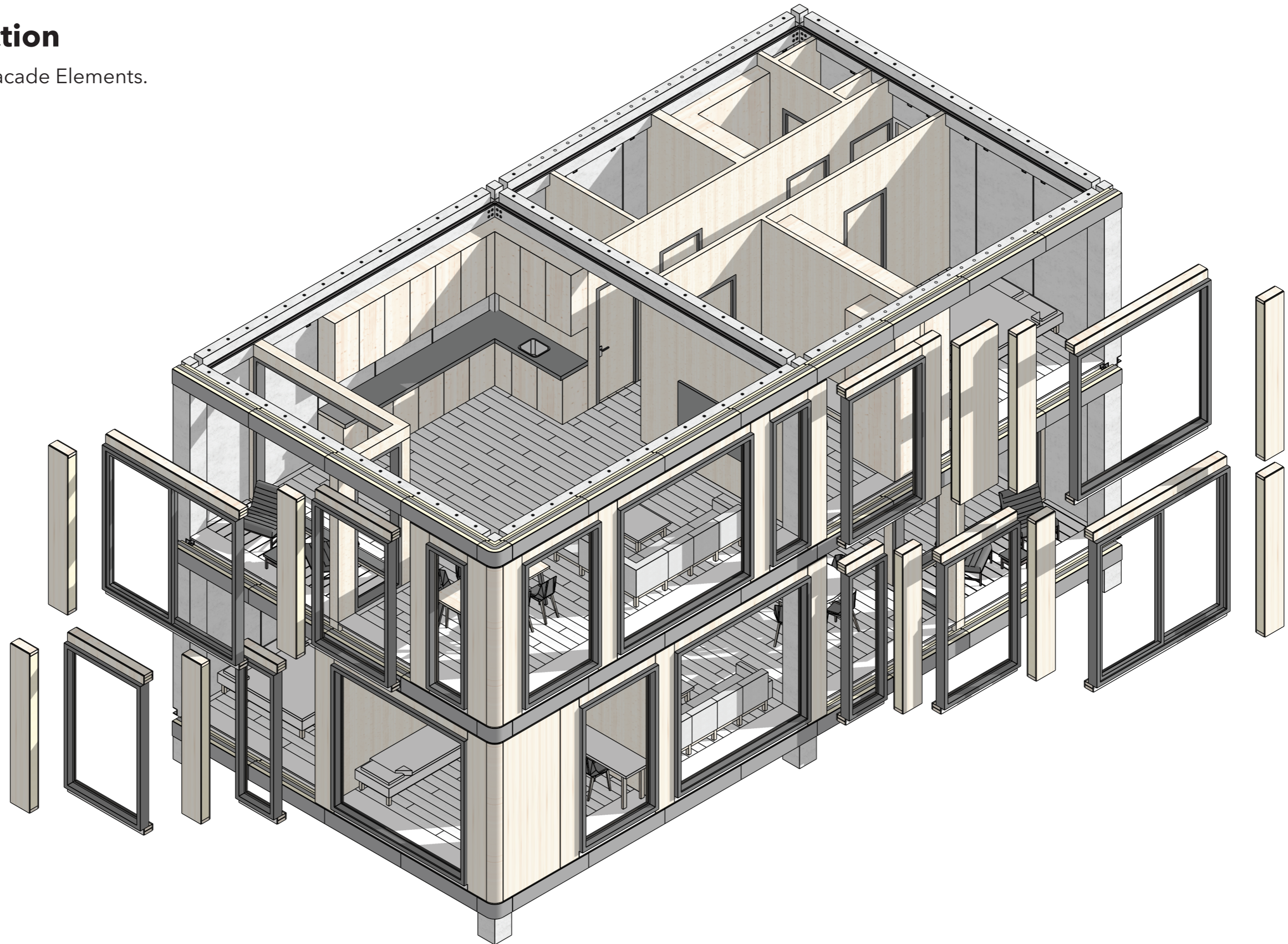

Circle Construction

Phase 05: Adding the Final Details.

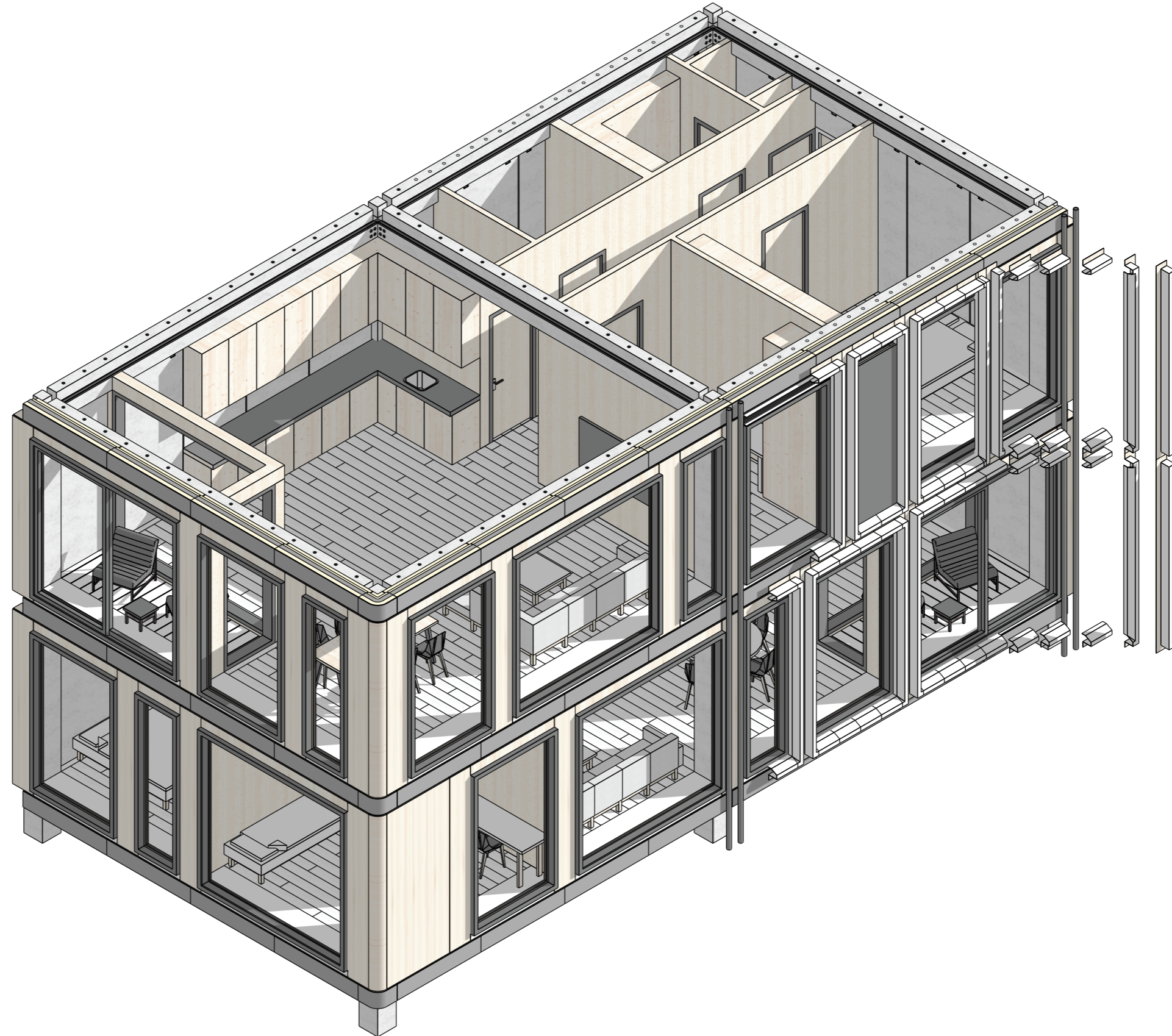

Circle Construction

Phase 06: Finished Project

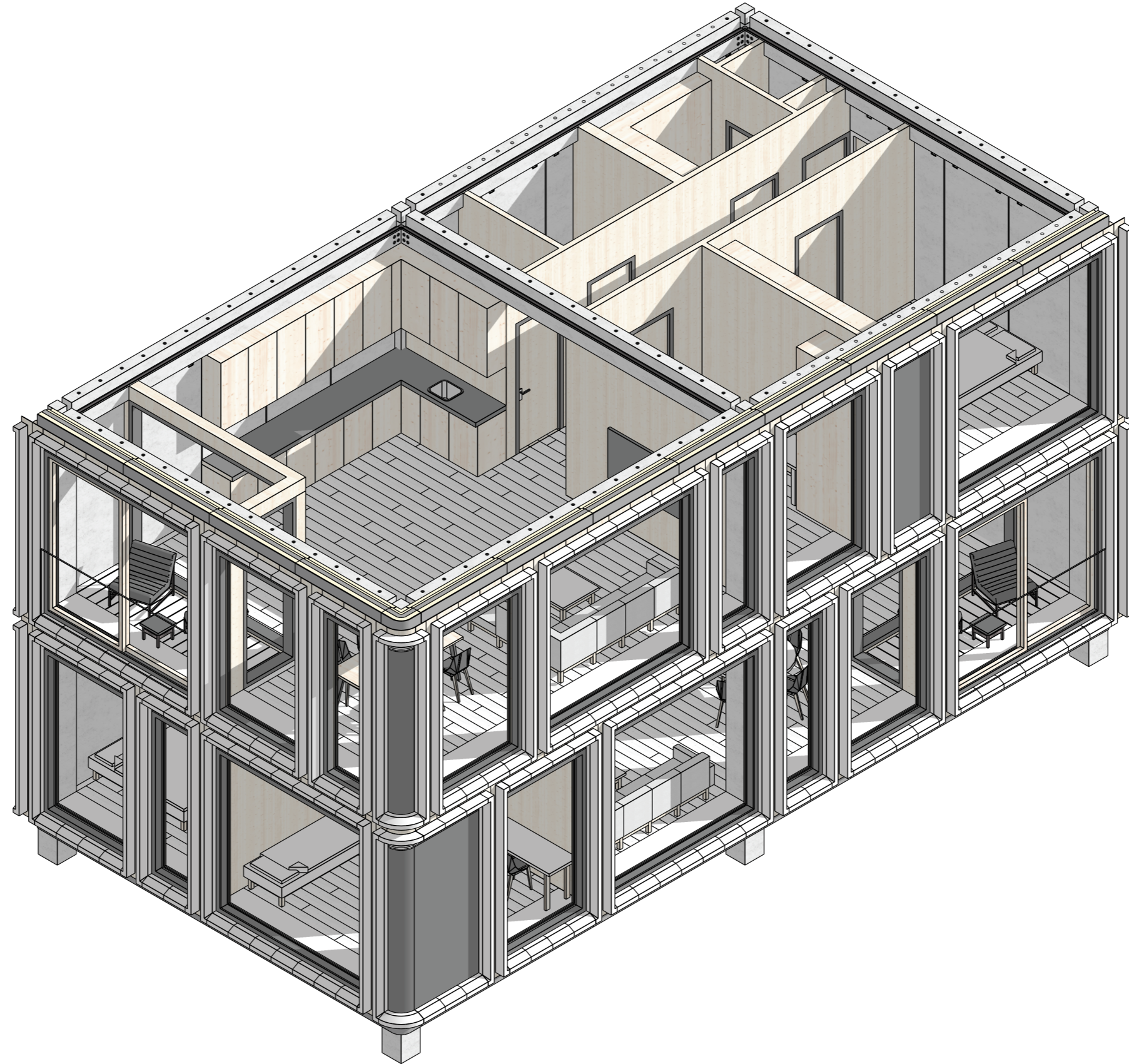

Circle Construction

Phase 01: Adding the Loadbearing Structure.

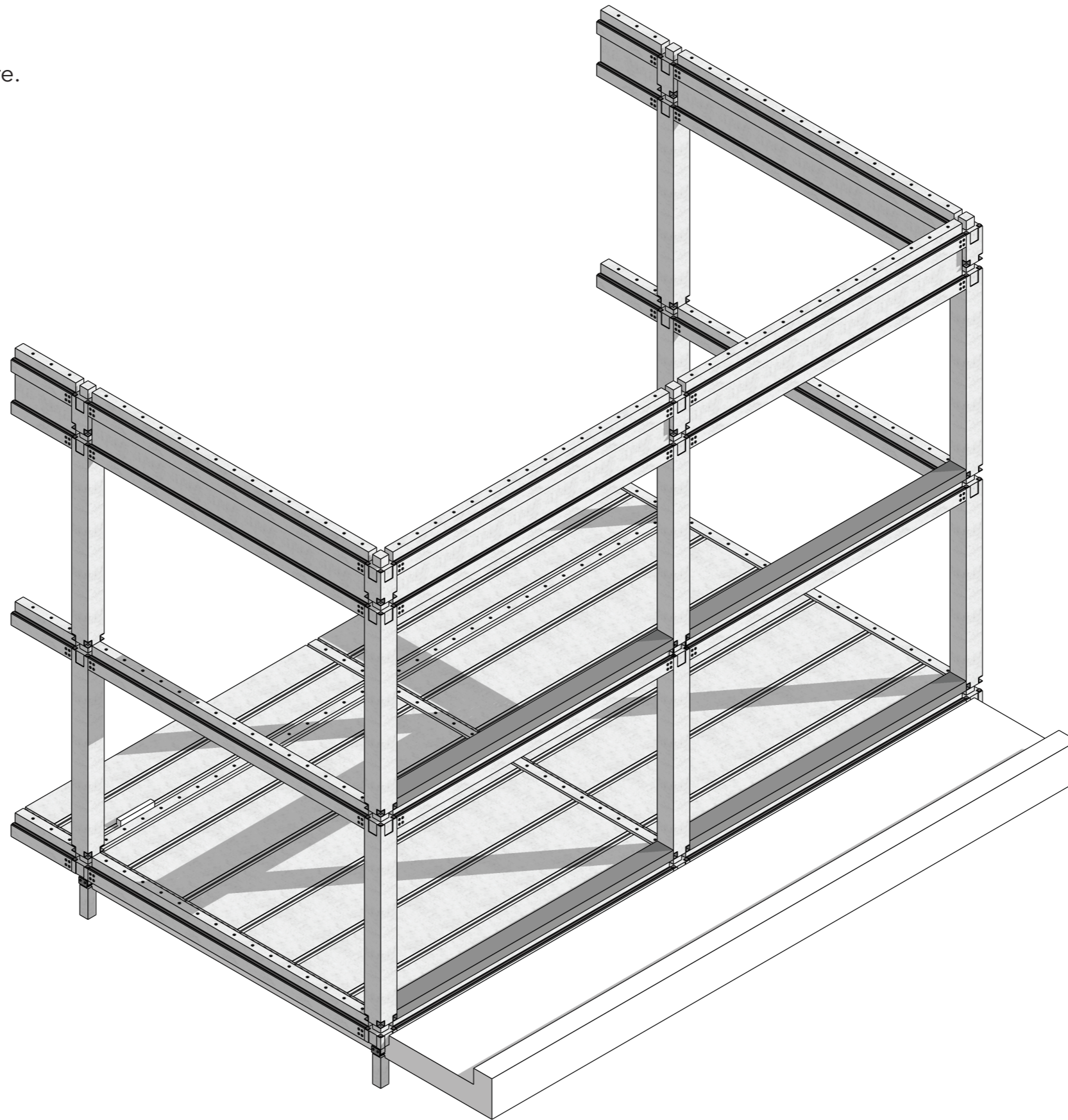

Circle Construction

Phase 02: Adding the Roof and Facade Structure.

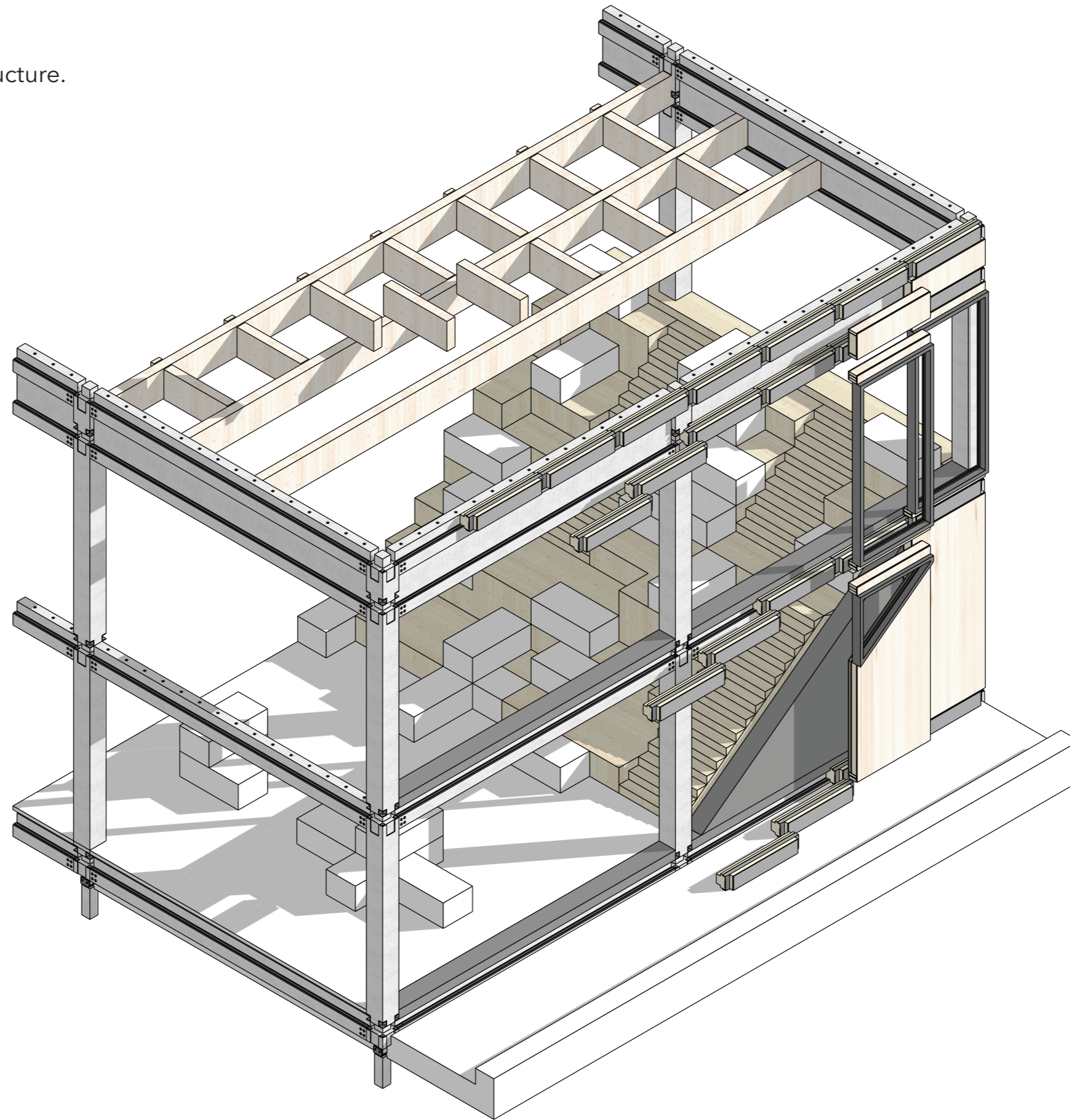

Circle Construction

Phase 03: Adding the Facade Elements.

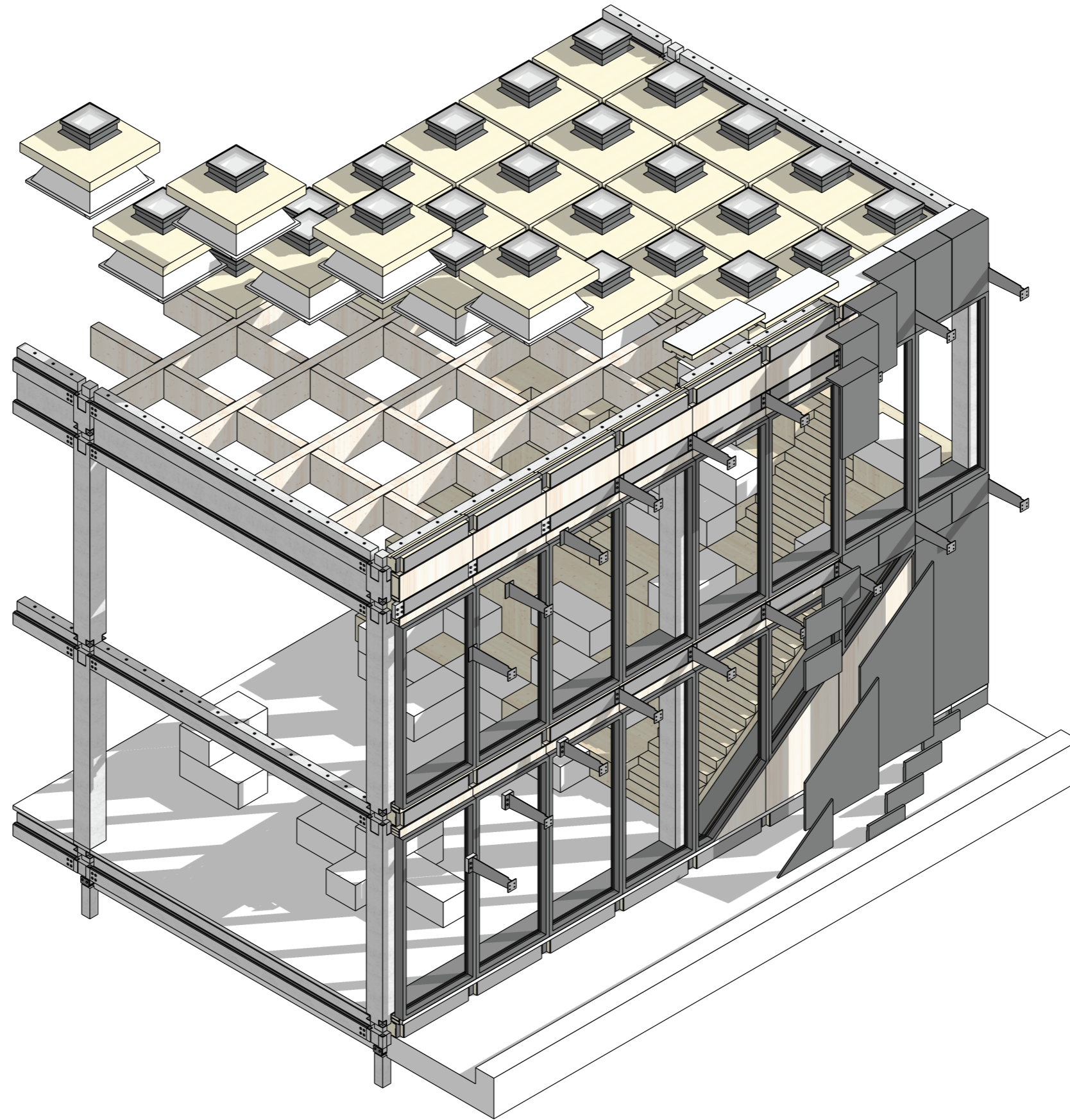

Circle Construction

Phase 04: Adding the Second Facade Skin.

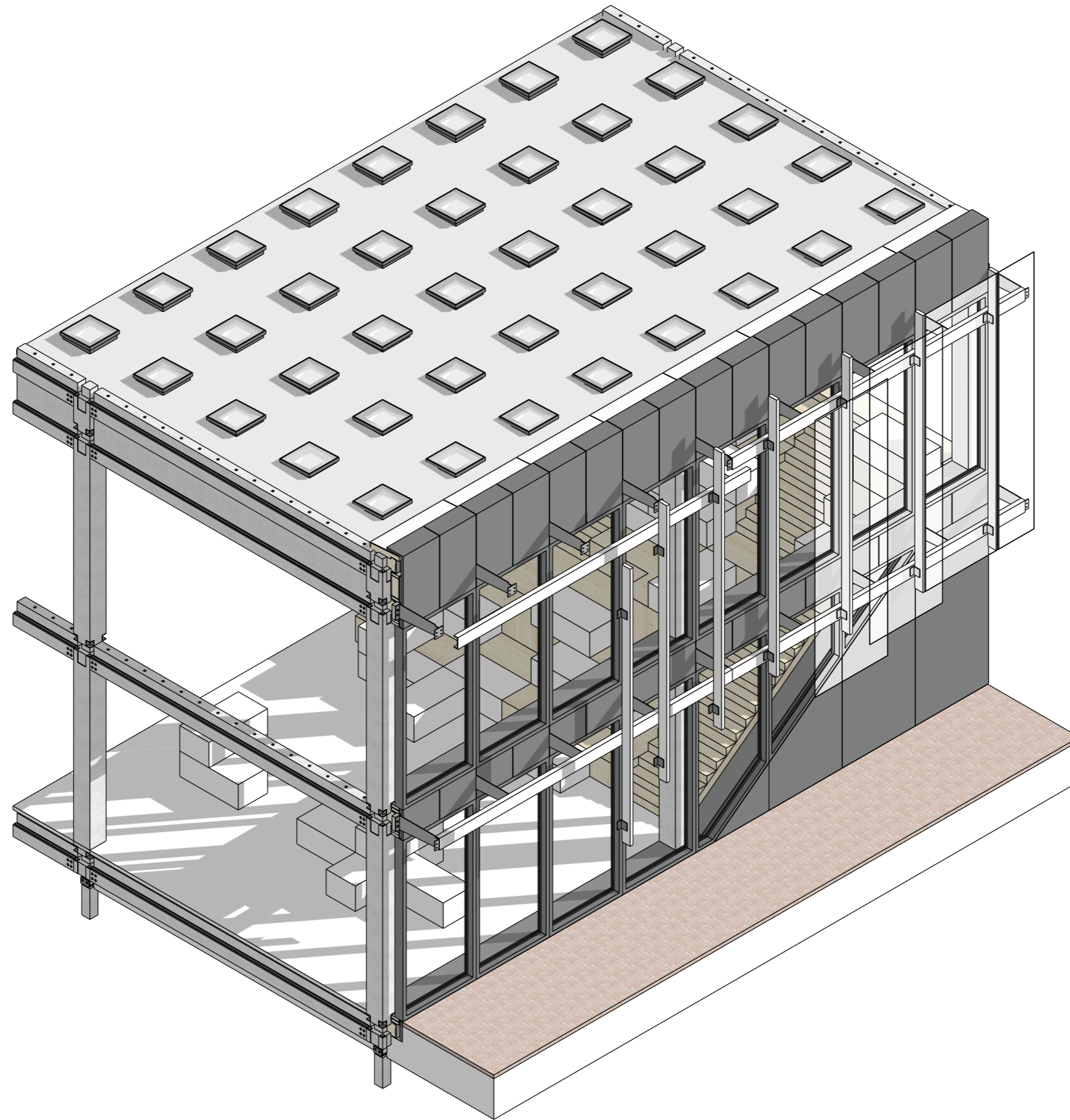

Circle Construction

Phase 05: Finished Project

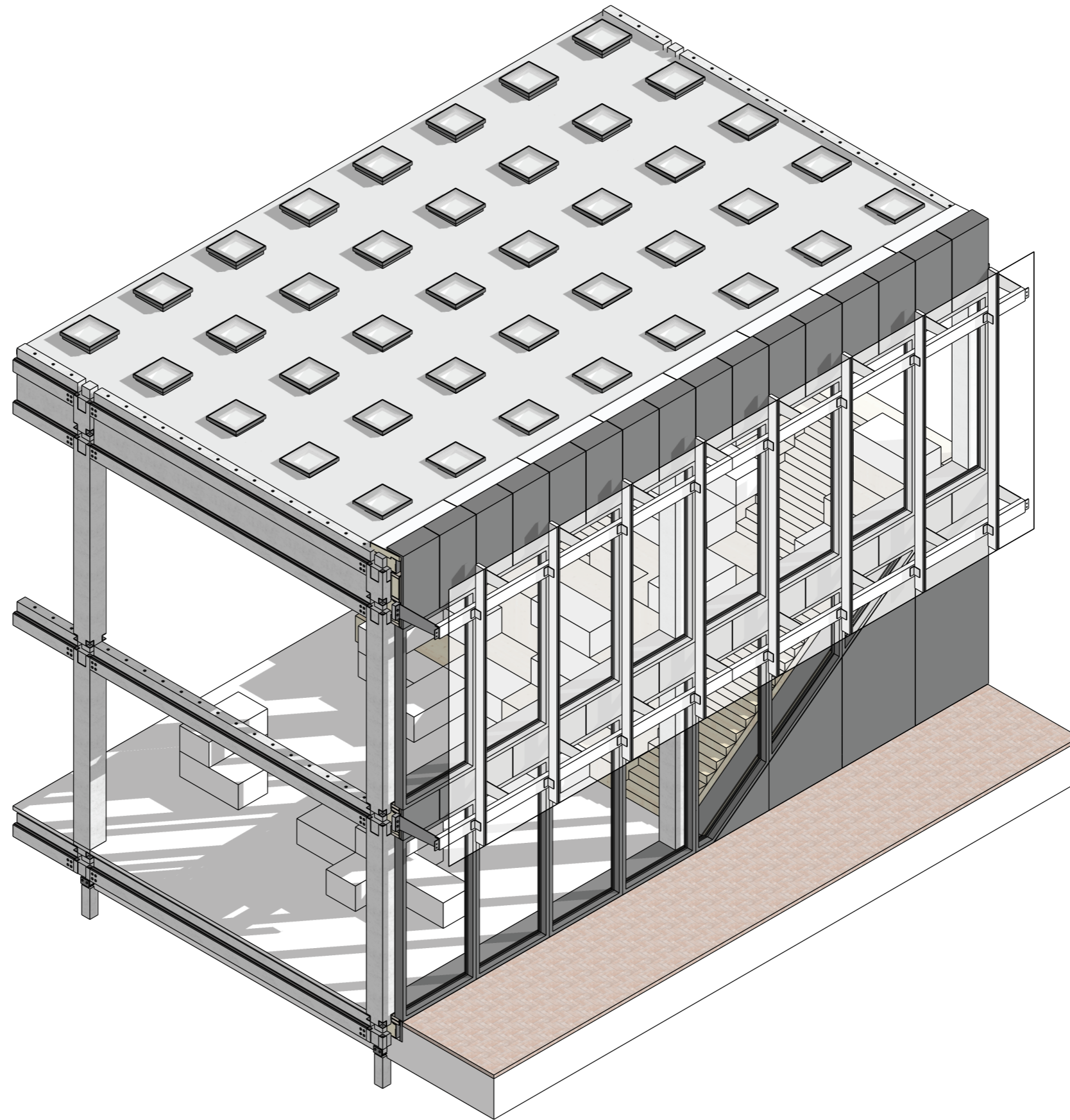

00 Ground Floor

Exhibition / Library, Café and Auditorium

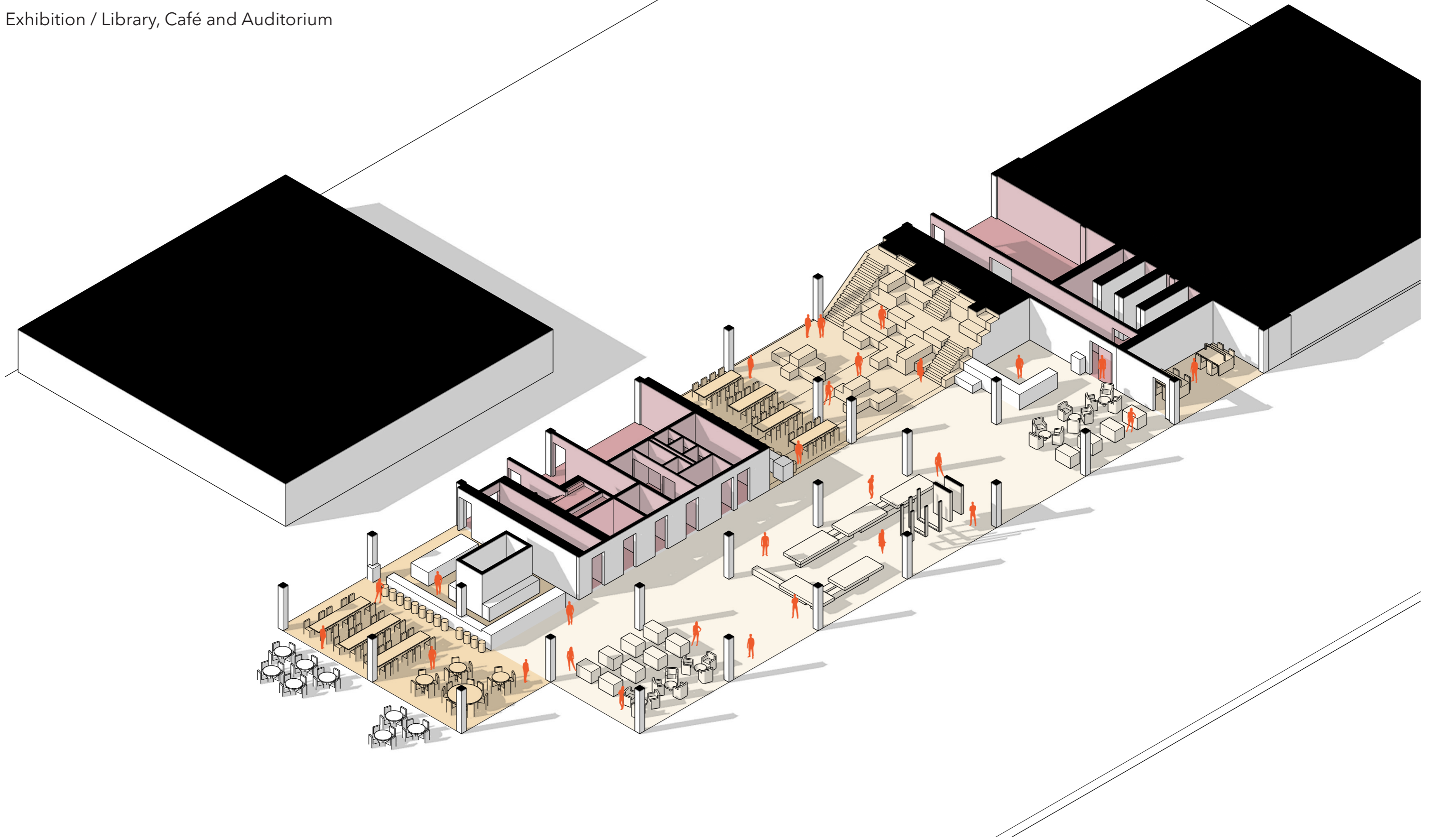

01 First Floor

Flexible Working spaces & Library

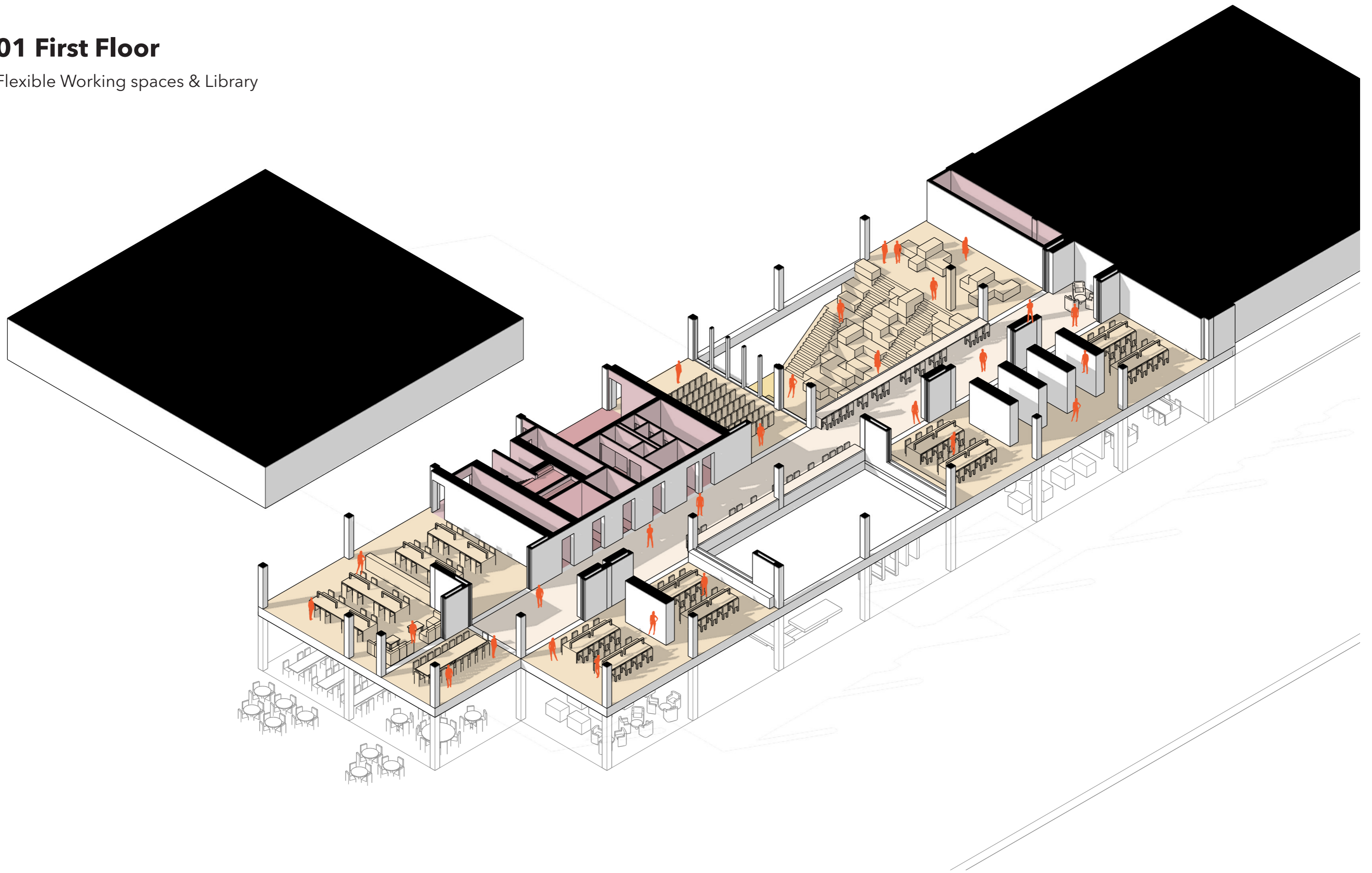

01 First Floor Alternate Layout

Educational and cultural spaces

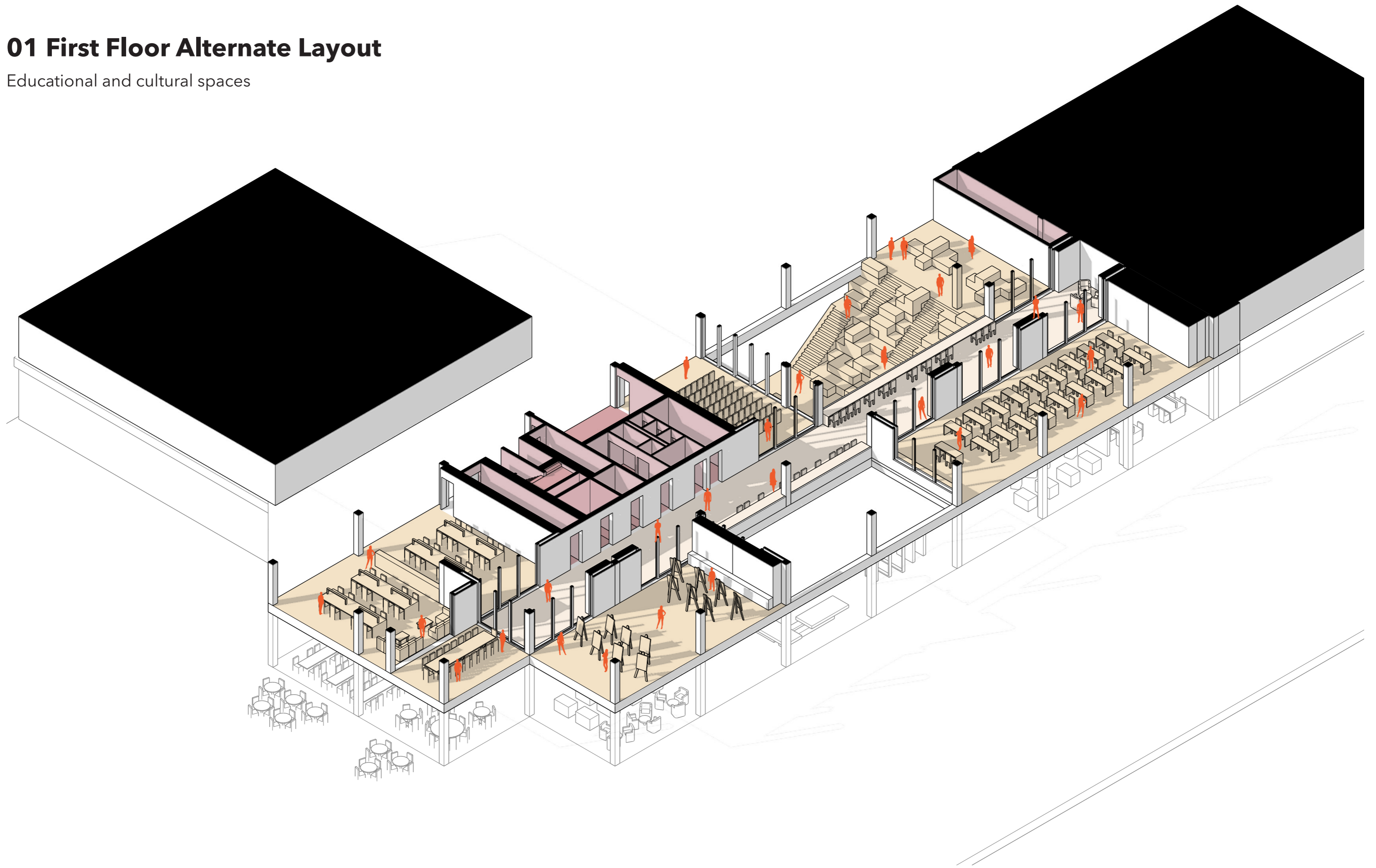

02 - 06 Housing

20 Apartments.

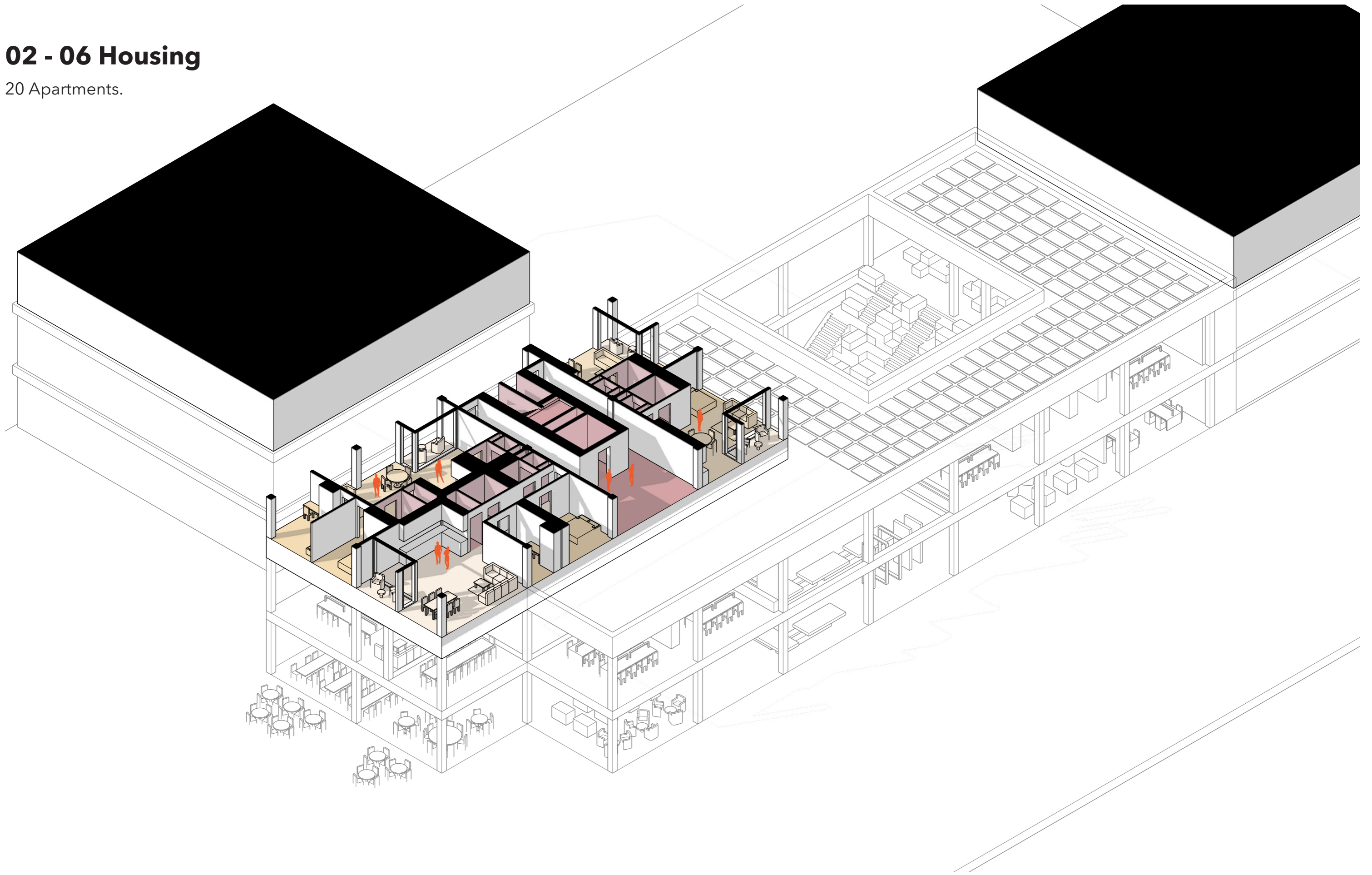

Complete Building

With Facade

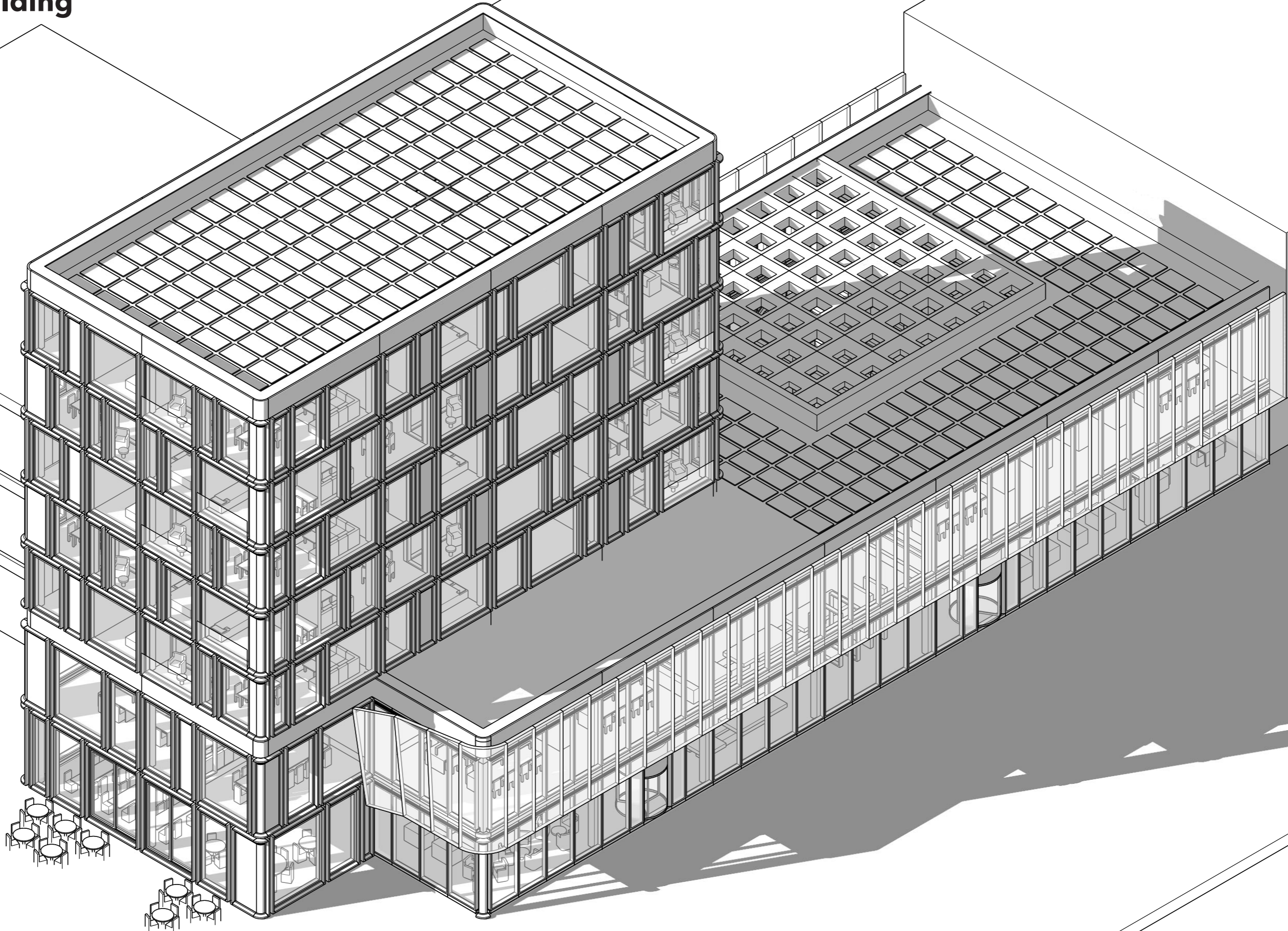

00 Ground Floor

Exhibition / Library, Café and Auditorium

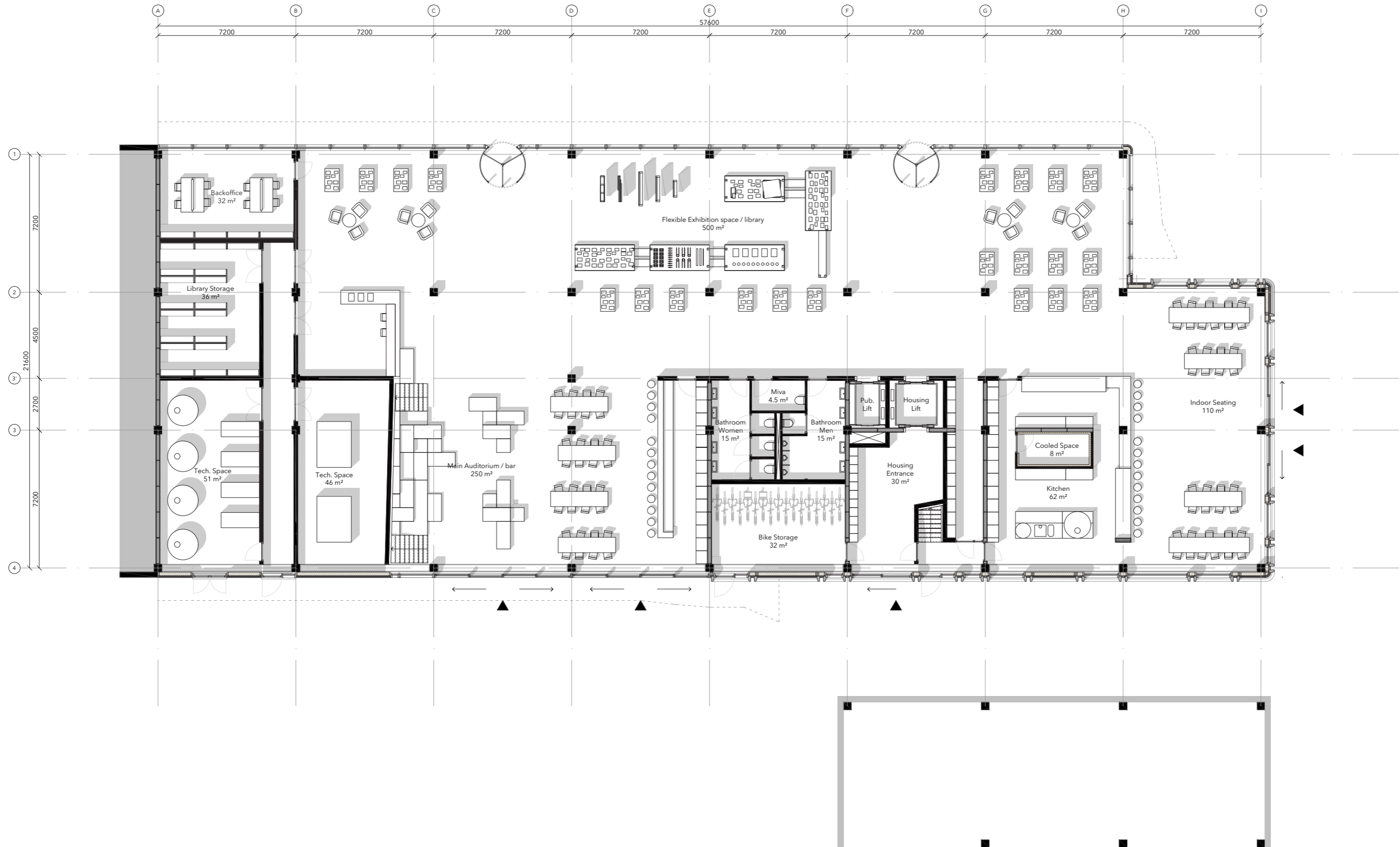

01 First Floor

Flexible Working spaces & Library

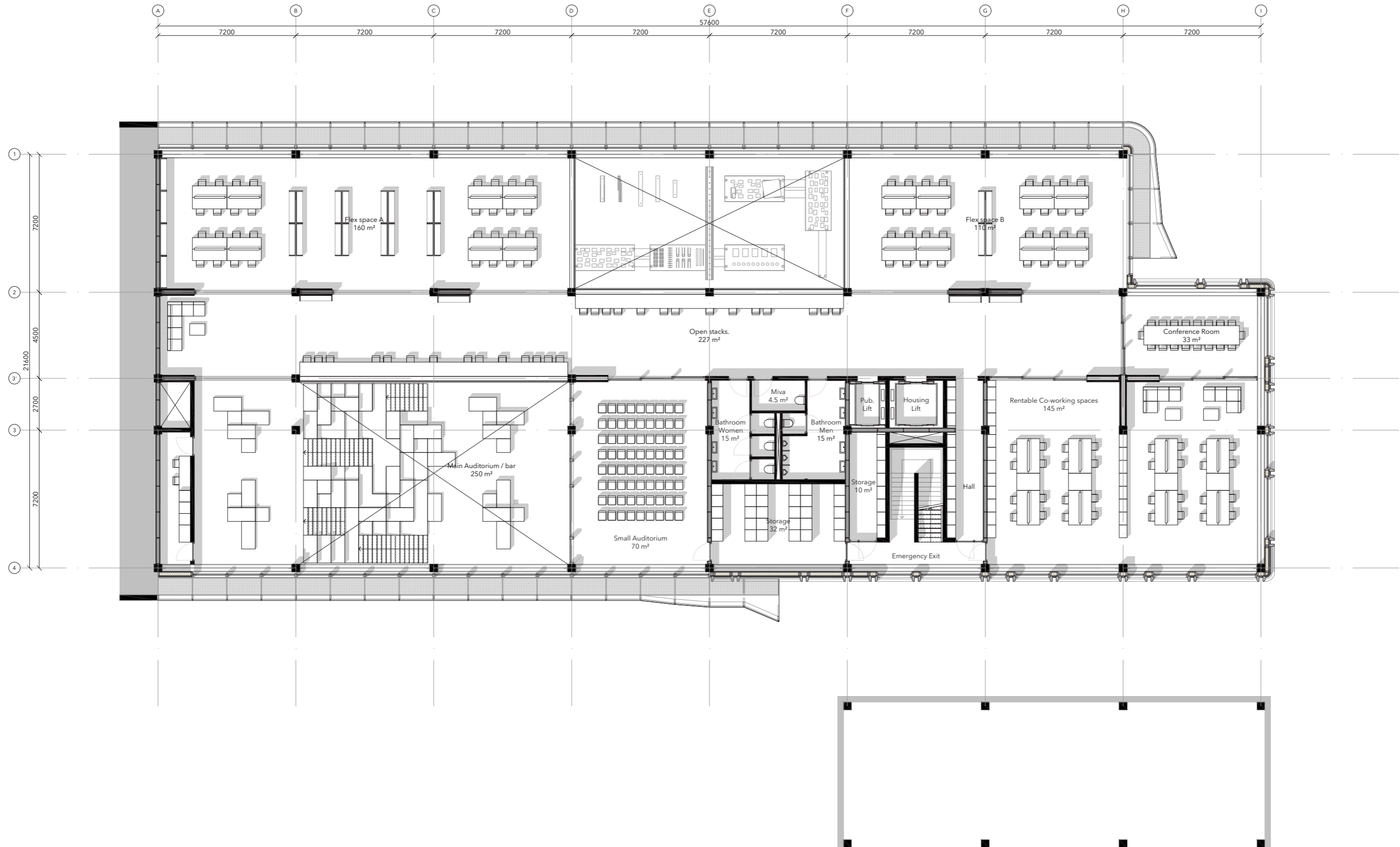

02 - 06 Housing

20 Apartments.

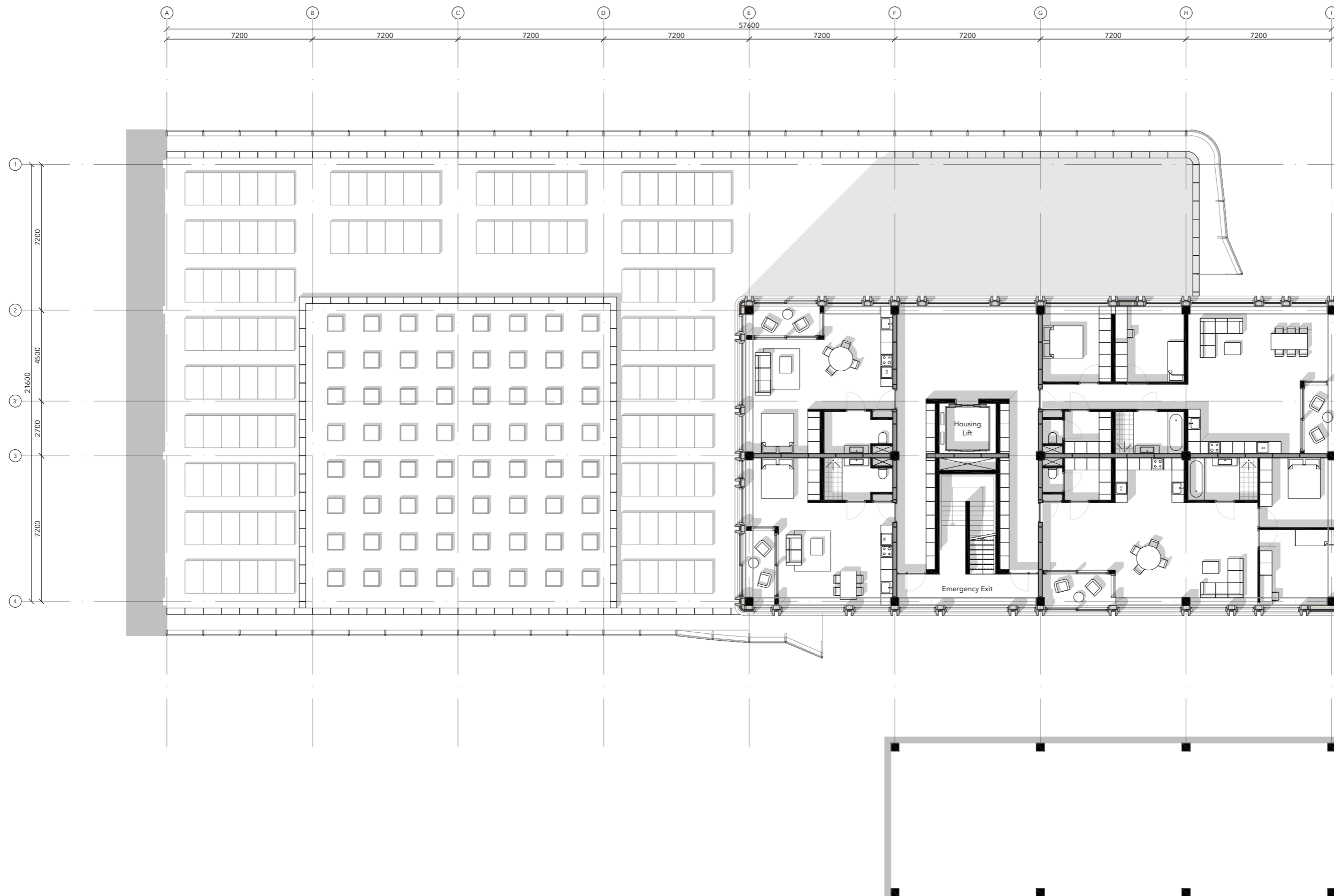

Section

Section AA

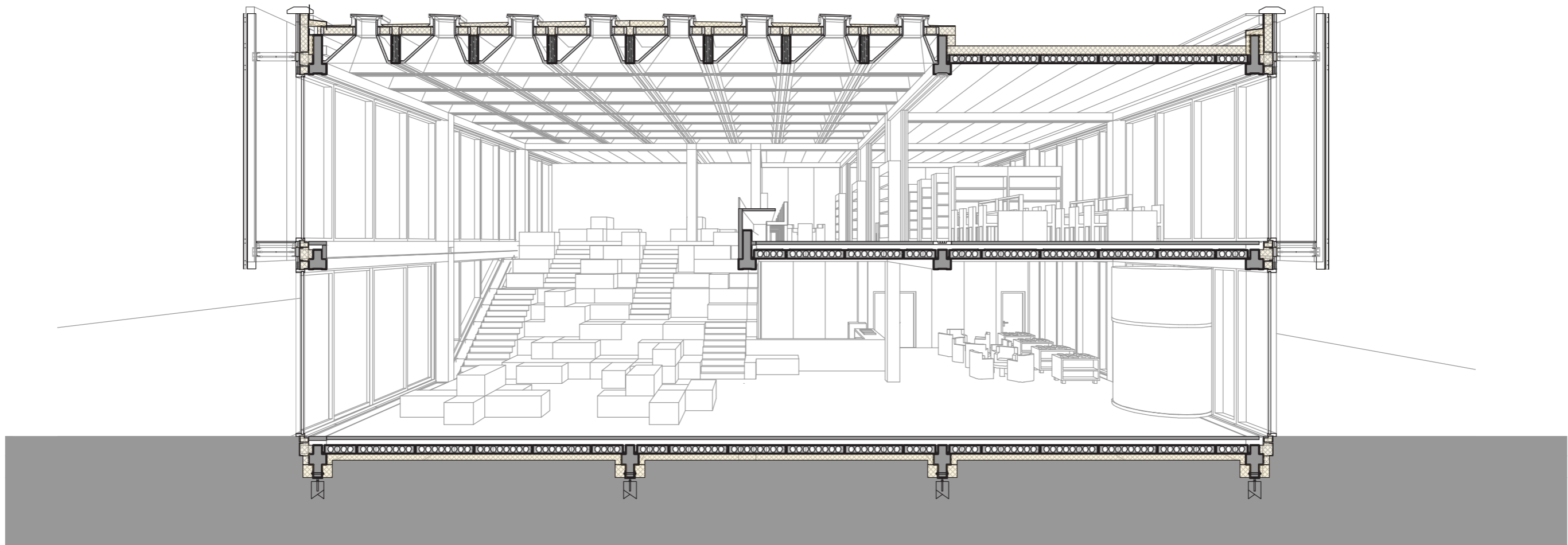

Details.

Fragment.

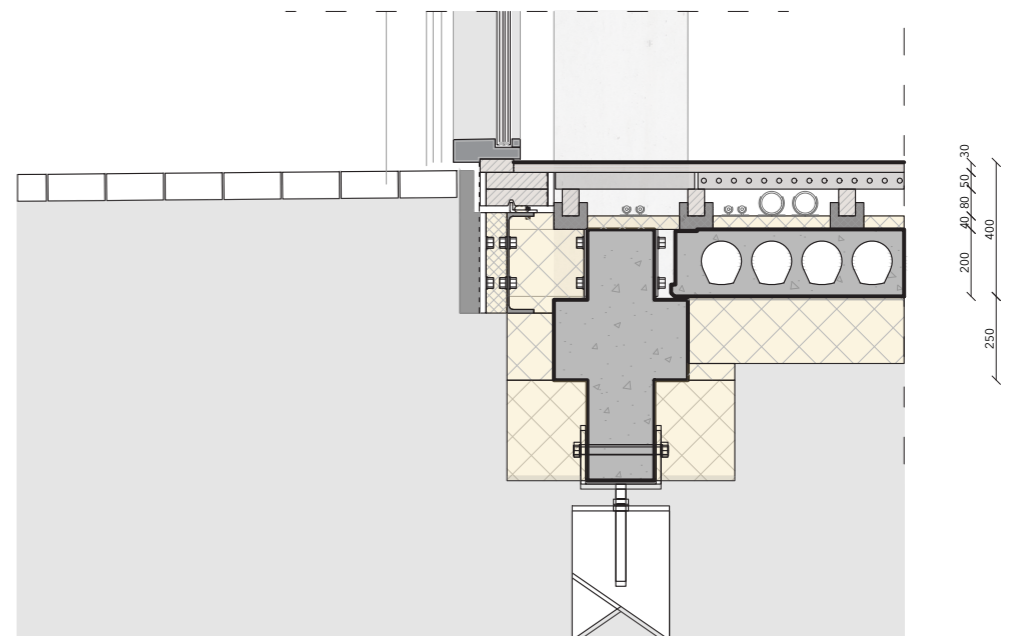
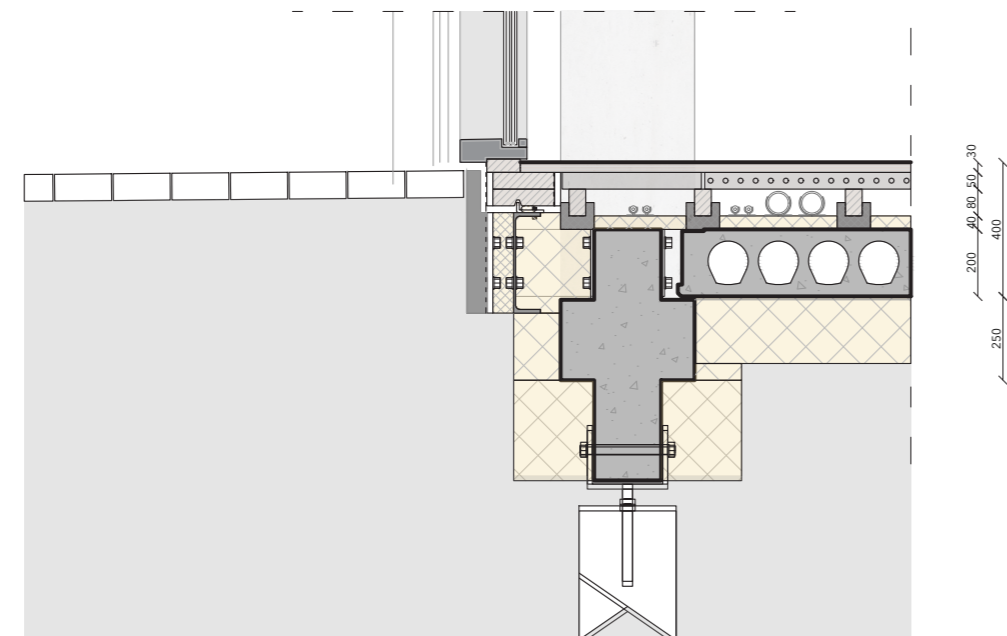
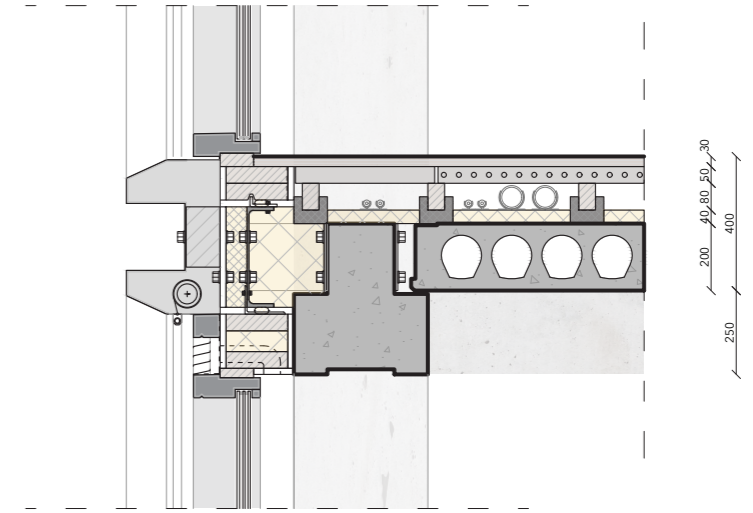
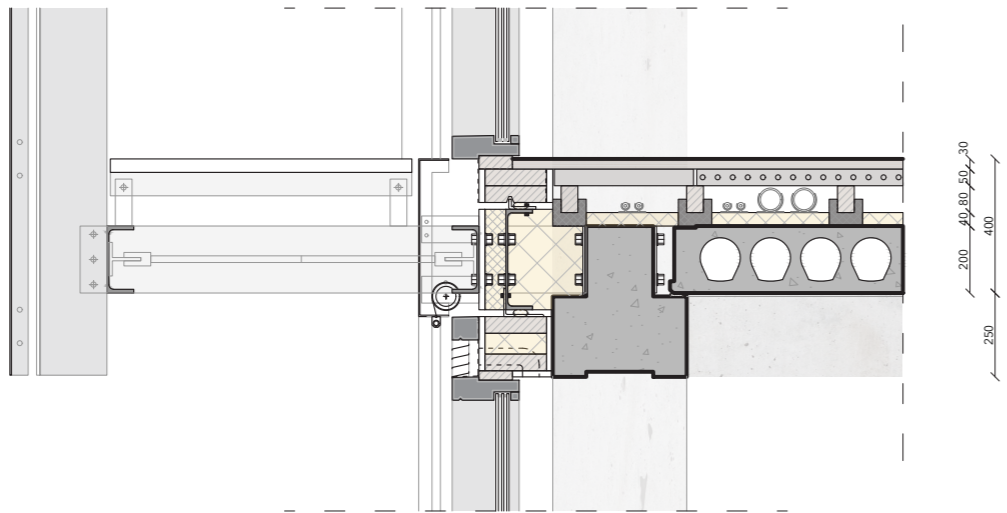
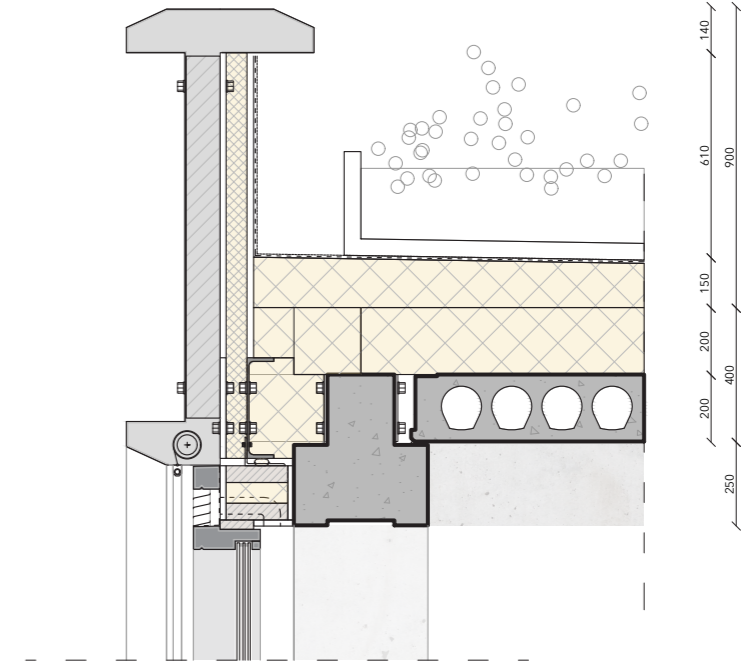
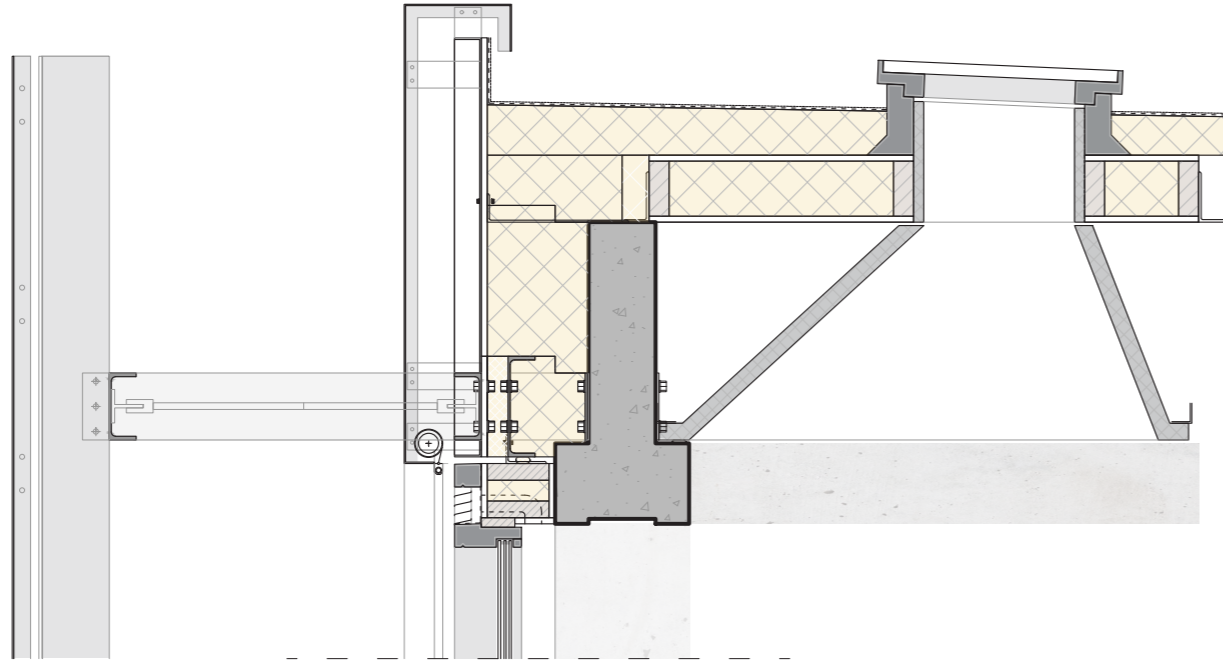

07 Roof
28.800 +p

Ceiling
27.500 +p

06 Housing
24.300 +p

Ceiling
23.900 +p

05 Housing
20.700 +p

Ceiling
20.300 +p

04 Housing
17.100 +p

Ceiling
16.700 +p

03 Housing
13.500 +p

Ceiling
13.100 +p

02 Housing
9.900 +p

Ceiling
8.600 +p

01 Flexible work spaces
4.500 +p

Ceiling
4.100 +p

00 Expo / library
0 +p

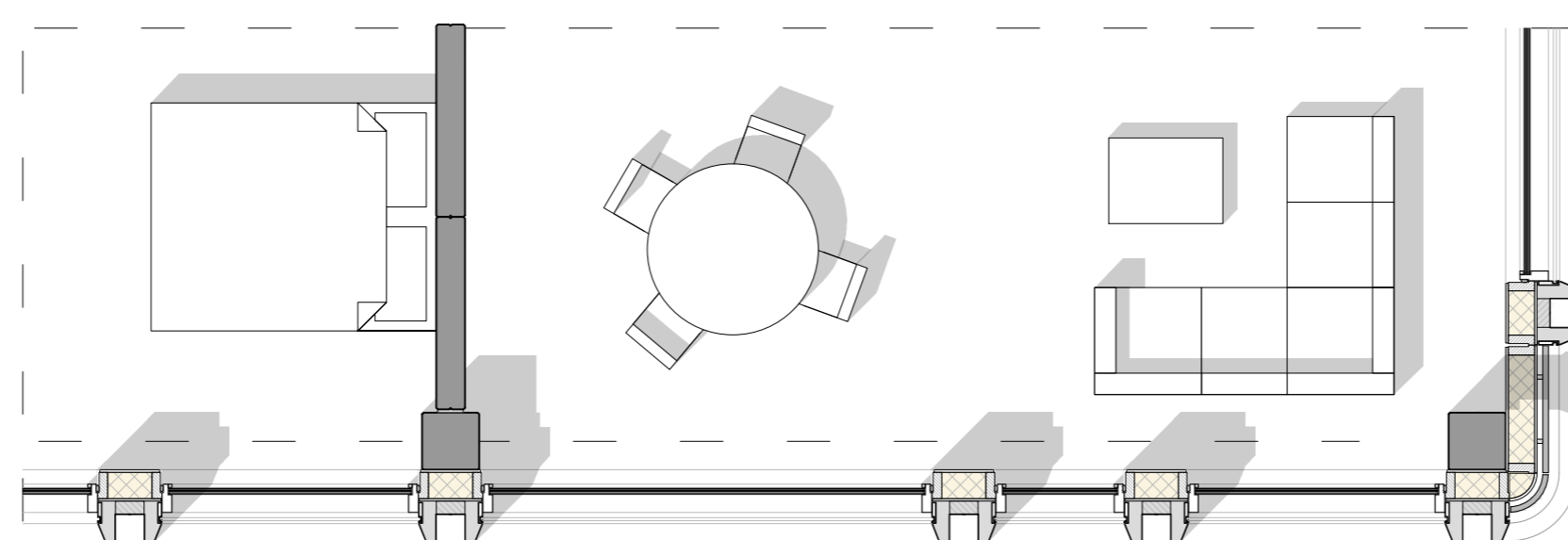
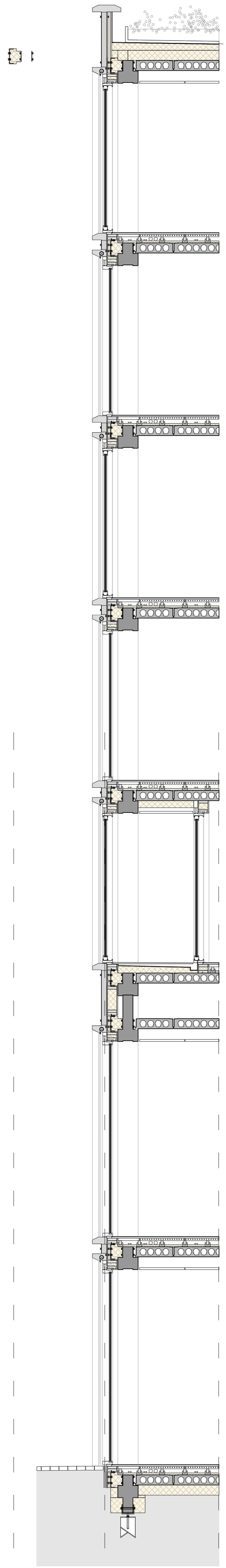
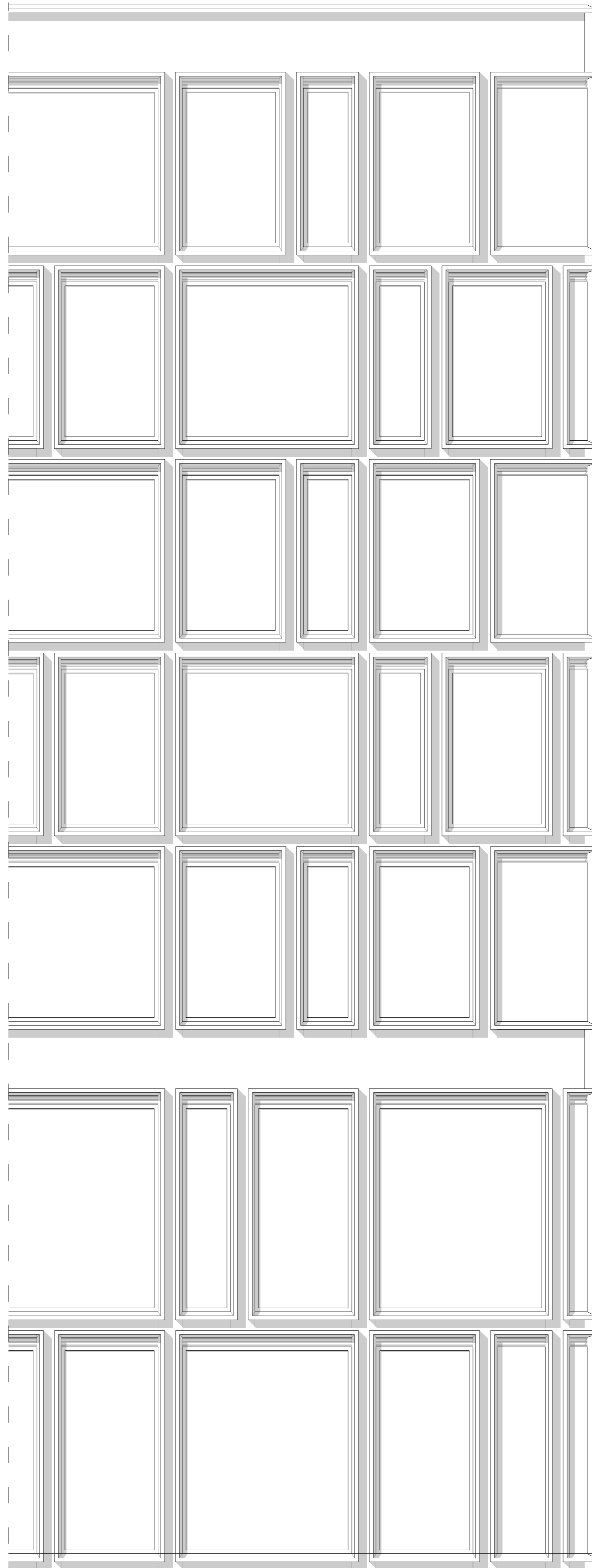

Third Floor

