

The Social Identity of a Three-Hundred-Meter Long Building

P5 - Graduation Report
Technical University of Delft

Stefan Lichtenveltdt
Student nr. 4791185

Interventions to the mid-rise building on the
Hoptille street

Amsterdam Zuid-Oost

Graduation Studio:

New Heritage
Adapting 20th Century Heritage

24-05-2021

Examiners P5:
Nicholas Clarke
Ger Warries
Lidwine Spoormans
Remon Rooij



Introduction

If the majority of inhabitants in a building are facing social issues such as language barriers, loneliness or being too afraid to come out of their apartment during the night we should feel obliged to assess the building in question. The needs of the people living in the three hundred meter long mid-rise building on the street of Hoptille are simply not being met. Inhabitants have little to no contact with their neighbours and are happy to see a familiar face if they come to the community centre next to Hoptille to try and solve any problems they have (volunteer De Handreiking, 2020). One of the architects of this long building in the Bijlmer, Sjoerd Soeters, understands now that the frequency of meeting neighbours in public spaces around your home are decisive for recognising one another, making acquaintance, and being part of a community (Sjoerd Soeters, 2020). However, since it was built, the building has been changed a lot due to social issues. A lack of visibility on the inner corridor has caused the access to the apartments to be changed drastically, resulting in the front of the building to be perceived as the back side. And an attempt to liven up the image of the building to be more individualistic by painting all the window frames in bright colours has left the building looking messy and unpleasant to look at according to the architect.

Problem statement

2.1 Social issues at Hoptille

The current situation is that the wall-like building of Hoptille, that was initially designed to be humanistic, failed to be what it was set out to be. Non-integrated solutions were rightfully used since the problems occurring were serious; shootings and other criminal activity were endangering the inhabitants at the time (government group, 2020). An overhaul of the Hoptille area is needed as the solutions that were put in place, e.g. the new housing access on the east side of the building and the colours that added to the west side of the building, are exactly the elements that have created the negative image of the building. The image of the building is in fact so poor that there are serious discussions being held about a potential total demolition of the building.

2.2 Identity

The identity of the Hoptille area seems very affected by wide and bare streets and sidewalks surrounding the buildings. One of the biggest contributions that journalist and well known urban planning criticus Jane Jacob's made to the field of urban planning is her understanding of the significance of streets and sidewalks. She argued that these elements of the built environment are the true public spaces of a city. This is in contrast with the idea that only public parks and plazas play this role in the city (Jay Wickersham, 2001). When looking at the east side of the three hundred meter long building of Hoptille you can clearly tell that the sidewalk has gained a very atypical identity due to the addition of the staircases on this side. Several interviewees mentioned the openness of the street, while at the same time mentioning how the staircases disturb this image. (interviews users group, 2020)

Heritage

Identity is one of the three main topics that Peter Howard discusses in his book "Heritage Management, Interpretation, Identity". The identity of an existing building, that could potentially be heritage, becomes important in this research as its main purpose is about feeling better, more rooted and more secure (2003, p. 147). We can instinctively tell that these feelings are beneficial for the social well-being of people. For a building to be considered heritage it does not need to be loved in the current situation as the identity of and attachment to the place is separate from the appreciation of it. As Howard explains, attachment to places may well be a complex mixture of love and dislike (2003, p. 152).

Small scale

As for the smaller scale of the neighbourhood, which fits the three hundred meter long building of Hoptille best, Howard (2003, p. 156) explains that the significance of the physical heritage tends to be negative. When a threat makes its entrance however, people start to take notice. Before the year 1800, old buildings were almost solely conserved when there was initially a threat of demolition. Current situation is that threats like these are being made to the wall-like building of Hoptille. According to a volunteer working and living at Hoptille there are two similar sized parties pledging to preserve as well as to demolish the Hoptille building. However, like Howard explains, the reasoning behind the people that wish to preserve the building, mainly the inhabitants, are not materialistic. Instead the reasoning tends to be about the small scale feeling and the social aspects that the block provides to the area (Volunteer De Handreiking, 2020).

Problem statement

Green

According to the results of the interviews on the streets in October this year the most controversial topic of the Hoptille area is the presence of greenery (interviews users group, 2020). Several people mentioned that they liked the fact that there was greenery placed in the central part of Hoptille where others complained that there was a lack of greenery in Hoptille. One of the inhabitants of Hoptille pointed out that she was especially disappointed in the variety of the green, a grass field with just a couple of trees did not offer enough variety according to her. The reasoning behind these wants came from her youth where she used to live outside of the city, the green identity of the village is much more appealing to her than the grey identity of the city. She did however mention that the Huntum neighbourhood in the H-Buurt, does offer this green identity in the city (interviews users group, 2020). In the work of Vaeztavakoli the identity of urban blue and green elements are discussed. They mention how recent health literature specifies that these urban green and blue elements offer therapeutic landscapes to their residents and visitors. Their paper discusses the identity of the Niasarm canal that can be found in the city of Isfahan, Iran. Their conclusions are that this urban element, that adds both green as blue to the city, has improved the sense of identity of the inhabitants as it has become a symbol for the city. The canal brought a sense of pride to the inhabitants and gave inhabitants a sense of belonging, feelings like these have the potential to improve the health of people (Vaeztavakoli et al., 2018).

2.3 Community

Creating a sense of community is an integrate part of the humanistic ideal that the architect tried to achieve with the design of the Hoptille area. A reason a social topic like this should be a big part of architectural design practice is that the physicality of buildings themselves can literally stand in the way for daily social activities to occur according to Jan Gehl (2011, p. 54). Now that a large portion of people living in Hoptille are dealing with poverty and presumably with loneliness, an opportunity for neighbourly contact that goes beyond a superficial level arises. As Jan Gehl explains mutual problems can help with creating more meaningful contact among neighbours (2011, p. 53).

Visibility

When designing the wall-like building of Hoptille the architect, Sjoerd Soeters, understood that having ground floor apartments meant that there should be a direct visual relation to the public area in front of these apartments. Reason being that a visual connection like this would keep the area safer. The first floor should be able to do the same, thought the architect at the time, which is why the first floor of the building features apartment-wide balconies on the west side of the building. What we know now however, as the architect confirms, is that these balconies are in fact hindering the visual connection from the apartment to the public space. For this reason Soeters believes now that if you design an apartment with balconies addressing the public area the designer should make sure that the balcony is not directly in front of the living room area (Sjoerd Soeters, 2020). In order to keep an area safer using high visibility on the public space Jane Jacob argues the importance of having mixed use areas. By having more than one primary functions in an area she claimed that a wider range of people would be attracted. Because

Problem statement

of the different functions these visitors would be spread over longer moments during the day and night, keeping the area more active, save and less congested at peak periods. She believed that this mix of use would be best if it was implemented at all scales of the city resulting in a fine-grained mix of functions (Jay Wickersham, 2001).

Inclusivity

Just as she is in favour of a mix in functions, Jane Jacobs is in favour of a rich mix of housing types. She understands that encouraging higher densities by implementing lower rise housing units means that there will be a higher percentage of ground area will be built resulting in less open space. However Jacobs thinks this is worth it as the mix of housing types brings in more diverse social structures (Jay Wickersham, 2001). Consequently this means that an area will be more inclusive as it offers not only the housing types with the highest demands but also types that could enrich the neighbourhood with other household types. Bringing in more types of people could potentially result in a need of clear hierarchy of social divisions of the public space. Jan Gehl (2011, p. 57) points out that single architectural projects can clearly reflect these social divisions by a hierarchy in the use of social spaces, from the living room up until the outdoor squares. One of the motivations for these physical divisions is that they can strengthen the community and democratic processes in individual housing groups as well as in the whole architectural project.

Problem statement

Accessibility

The access to the long building of Hoptille has been altered multiple times over the years turning the original back side of the block into the front side. The architect of the building points out that the entirety of the building was in fact schemed in a way to have the entrances on the other side of the block (Sjoerd Soeters, 2020). Besides this issue it is not too difficult to notice that the staircases on the east side are not accessible for people that simply cannot use stairs. Apart from people that are physically unable to do so, it also hinders people that use strollers and elderly who are afraid of using stairs.



Figure 1. West side of the building with original staircase in the distance. From “Stadsarchief Amsterdam”, by Archief van de Gemeentelijke Dienst Volkshuisvesting, n.d.

(https://archief.amsterdam/beeldbank/detail/3b27470f-f0e0-9cd3-472e-caecb321e7de/media/87c8f441-37ef-b85f-34eb-9f919e3bd-8ba?mode=detail&view=horizontal&rows=1&page=13&fq%5B%5D=search_s_geografische_aanduiding_sk_geografische_naam:%22Hoptille%22&sort=order_i_sk_date%20desc&filterAction).

2.4 Conclusion

The topics of identity and community described above form the totality of the problem statement. The complexity of bringing all the parts of these two topics together in the design proposal will be the challenge of this graduation process.



Figure 2. East side of the building with new staircases in front of the original back side of the building. From “Stadsarchief Amsterdam”, by Archief van de Gemeentelijke Dienst Volkshuisvesting, n.d.

(https://archief.amsterdam/beeldbank/detail/b3e89d90-ef7e-d922-1f8b-2bacd5373b64/media/7d0a08ac-f072-ca7f-8e70-91e9b-6c38561?mode=detail&view=horizontal&rows=1&page=4&fq%5B%5D=search_s_geografische_aanduiding_sk_geografische_naam:%22Hoptille%22&sort=ran-dom%7B1608114363416%7D%20asc&filterAction).

Physical problems

3.1 Localizing the interventions

Further research after defining the problem statement was needed to define where architectural inventions could be made to resolve issues. Comparing the vision of the architects to the reality of the building block showed a big difference. A big reason for this seems to be the removing of the corridor in the building. The element that was supposed to give the building a high social control turned out to be a space for a lot of criminal activity due to sparing costs on this corridor. The

criminal activities resulted in the removing of the corridor along with the addition of the new external housing access. This new access system has resulted in several social issues that currently play in the building. Out of this it can be concluded that the initial solution to the criminal activities has been too linear.



Initial solution to the problem: **too linear**

Figure 3. Scheme physical problems

Physical problems



Figure 4. straight-on picture of the north-east facade

3.2 North-east side of the midrise

The results of the street interviews pointed out that the external entrances are unwelcoming and a disruption to the public space. The transition between the public and private area are also very harsh as the stairs and staircases are directly placed on the public sidewalk.



Figure 5. Perspective picture of the north-east facade

Physical problems

3.3 South-west side of the midrise

This facade used to be the front side of the building block. This can be seen by the aesthetical elements that were put onto this facade. However since this side of the building is now the backside there is very little liveliness on this side of the building. The fact that there are no meeting places also makes that the public areas here are hardly used. There is no sense of ownership over the public space and there is little visual connection to it as well. The street interviews revealed that the green area is often perceived as an inner garden for the building blocks but in reality it does not operate as such.



Figure 6. Perspective picture of the south-west facade

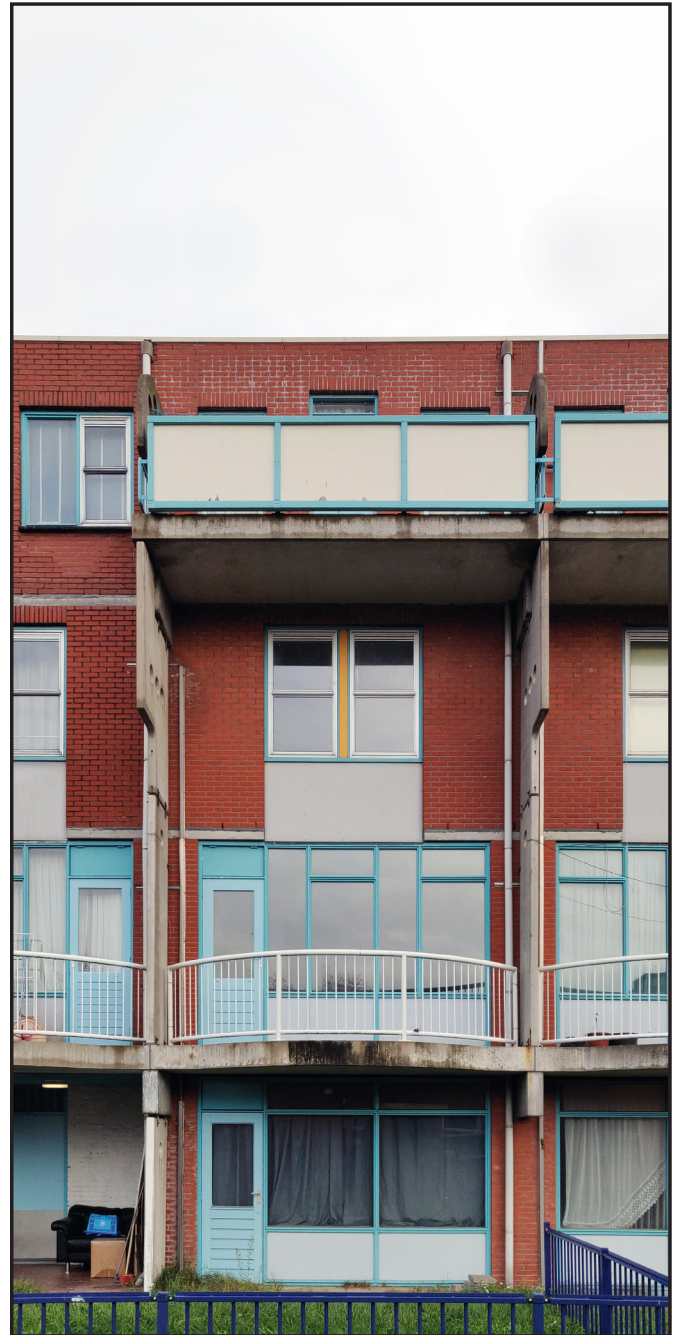

Figure 7. straight-on picture of the south-west facade

Physical problems

3.4 Problems inside the building

An interview at the community center revealed that there are a lot of social issues present in the mid-rise building on the street of Hoptille. Loneliness and unfamiliarity with regards to neighbours and activities going on in the area form a big problem.

“There is a lot of poverty and a lot of loneliness. In a building like this you can disappear completely into solitude. People have little contact with their neighbors.”

“Some people are even too afraid to take the elevator at night.”

“People are not proficient in the language, so they are not able to read announcements properly. Not knowing what’s going on around you. That is very big issue here.”

- Volunteer at the community center next to Hoptille, 2021

The building also has several technical issues. Bad insulation, leakages and noise disturbance being the main ones. Technical problems like these can also turn make the social problems worse, noise disturbance can become a much bigger problem if the inhabitants are unfamiliar with one another for example.

3.5 Intervention based problem statement

These assessed physical problems of the building allowed for the forming of a problem statement that is more geared towards making architectural interventions in the building. This problem statement reads as follows:

The mid-rise building of Hoptille lacks an integrated designed housing access. Because of this the inhabitants are experiencing social issues, like loneliness and feelings of isolation.

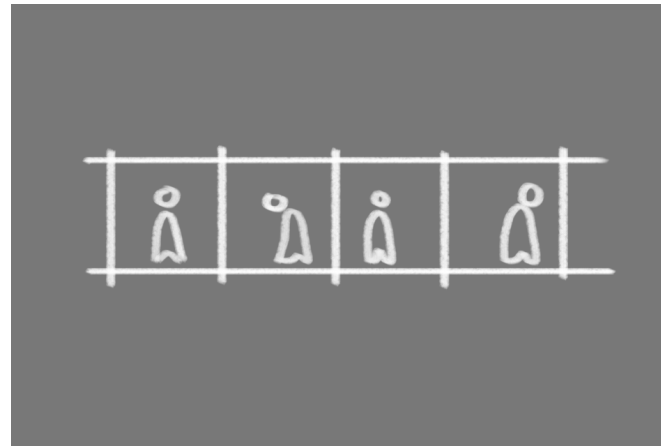

Figure 8. Loneliness and isolation

Social, spatial and heritage values

4.1 Social, spatial and heritage values

During the group research phase different types of values were assessed for different specific locations. The scheme below shows the scheme of the social and spatial values along with heritage values for Hoptille street. The social values were based on theory of J. Max Bond Center and the spatial values were based on theory of Jan Gehl. The Heritage values that were added to the scheme were based on theory of Alois Riegl.

Marked with a yellow border are some of the negative values that made me decide to make some initial interventions that can be seen in the next chapter. The positive elements marked with a green border are the values that have been selected as the elements that will be preserved as much as possible with the interventions that will be made.

"Hoptille"		SOCIAL VALUE				SPATIAL VALUE			HERITAGE VALUE				
		Diversity	Accessibility	Inclusiveness	Material Affluence	Protection	Comfort	Enjoyment	Historical	Intended Commem.	Use	Newness	Relative Art
		-3	0	3									
Urban structure	Elevated road	0	2	0	0	1	-3	0	3	0	2	0	0
District	Public Green	1	2	-2	1	1	3	2	3	0	-1	0	1
	Street art	1	0	2	2	1	1	2	0	3	0	3	3
Surroundings	Parking garages	0	1	0	0	1	0	0	3	0	2	-2	0
	Separation by midrise	0	-2	1	0	2	2	0	2	0	0	0	0
Building block	Mid rise height	-1	0	-1	0	0	0	2	3	0	2	0	0
	Mid rise horizontality	-1	0	-1	0	0	0	-1	3	0	0	0	1
	Low rise height	-1	1	0	0	-2	0	3	3	0	2	0	0
	Angle of low rise houses	1	-1	0	0	0	-1	0	2	0	0	0	1
Skin	Passages midrise	0	2	0	0	-2	-1	-1	2	0	2	0	1
	Round balconies	1	1	1	0	0	1	1	2	0	2	0	2
	Bricks	0	0	0	-1	0	0	-2	1	0	1	-2	0
	Windows	1	0	0	1	-1	-2	-2	0	0	1	-2	1
Structure	Communal staircases	0	1	-2	0	0	0	0	0	0	2	-1	0
Services	HoptilleHuis	0	2	2	0	1	2	0	0	0	3	1	0
	Technical services	0	0	0	0	-2	-3	-1	0	0	-3	-2	0
Space plan	Gardens	2	2	3	1	2	1	0	0	0	1	0	-3
Stuff	Front staircases	0	2	-2	-2	0	-1	-1	2	0	2	1	2
	Community garden	0	0	1	2	0	0	2	0	0	2	0	0
Spirit of place	Multicultural neighborhood	3	0	1	0	0	0	0	3	0	0	0	0
	Anti Bijlmer	2	2	3	2	0	0	1	3	0	0	0	0
	CIAM aspiration	-3	-2	-3	0	2	1	1	3	0	0	0	0

Figure 9. Social, spatial and heritage values scheme

Initial modifications

5.1 First interventions

Based on the social and spatial value assessment the decision was made to remove all external housing access systems that were added when the corridor of the initial design was removed. The assessment pointed out that the windows and doors were of low value which made me decide to have all of them removed or replaced.

The 3D models below first show a part of the building without these access systems followed by a version without all the windows and doors. This last model shows the building stripped down to the parts that have the potential to be preserved for their values.

South-west side of the building

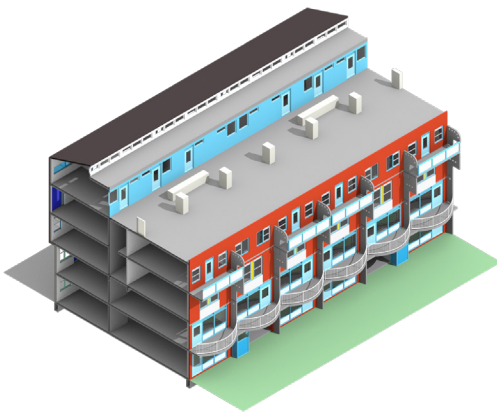

North-east side of the building

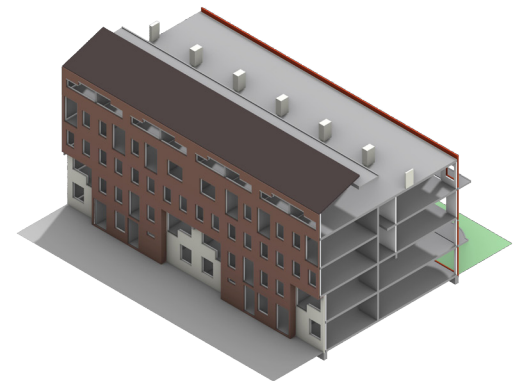
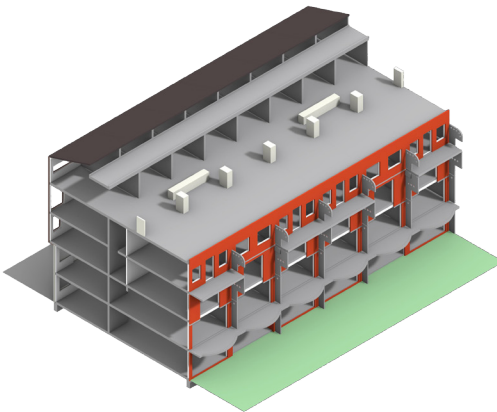
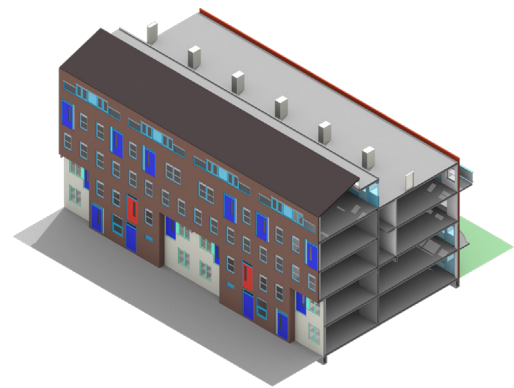

Figure 10. Four 3D impressions to indicate the initial modifications made

Highest evaluated values

6.1 Historical values

The volume of the building block holds the most historic value as it tells the story of how the architects wanted to block the view to the typical flats of the Bijlmer area. This strong reaction to the neighbouring high-rise would be lost by dividing this long building block into several parts. It also shows that the architects wanted to create a more lowrise environment striving for a more humanistic approach to architecture.

6.2 Use values

The unique concrete pre-fab construction of the building can be re-used in order to save energy and so the embodied energy of the structure won't go to waste. The brickwork of the building as it stands can also be re-used and will play a big factor in the recognizability of the existing building after the interventions.

6.3 Architectural values

Some specific elements of the mid-rise building are very distinctive for the architecture of the block. The vertical concrete slabs on the south-west side being one of them. The circular protrusions and the rounded corners make them especially recognizable. The rounded balconies on the south west facade and the strong repetitions in both of the facades form the characteristics of the building.

6.4 Rarity values

The fact that this building is one of the first buildings that Sjoerd Soeters worked on, who is now a well-known architect in the Netherlands makes the building one of a kind. The unique three-hundred-meter long, 4 to 5 story tall volume makes the building unique as well.

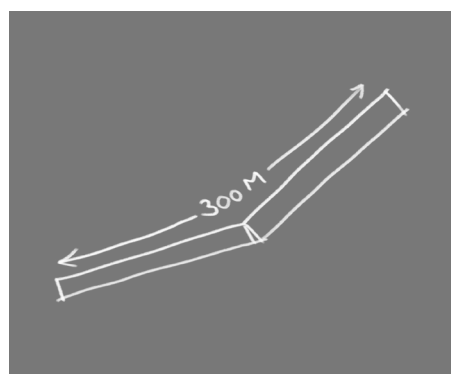
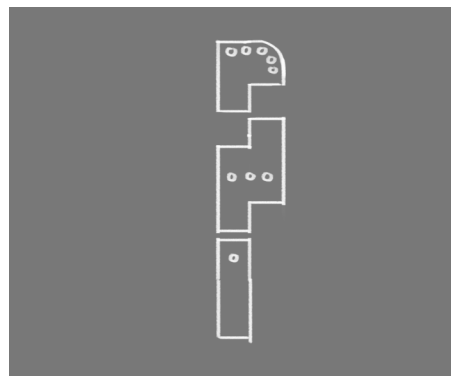
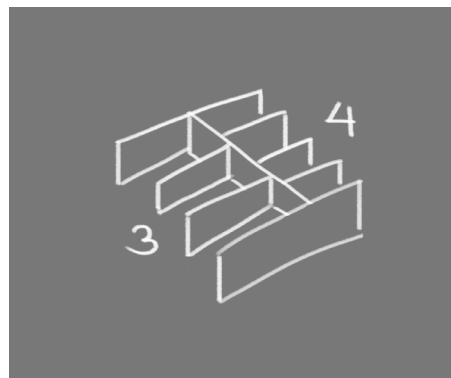
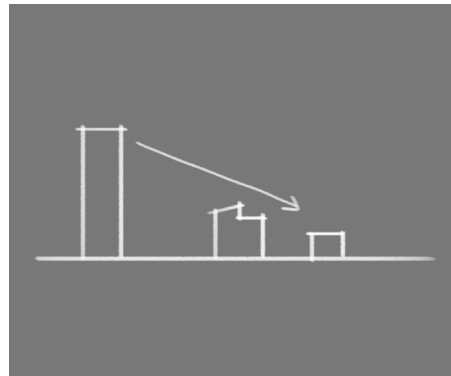

Figure 11. Four sketches for the four highest evaluated values

Reflection on methodology

The entirety of the research can be classified in three stages, the pilot stage in Almere Haven, the collective research of the H-Buurt and the individual design process on one of the three locations of the H-Buurt. The methodology behind the first two collective parts is explained in the 'Methodology of the collective research' while the individual part is elaborated in the 'Methodology of the individual research'. As the scheme below illustrates, the group of students was divided in two for the pilot in Almere Haven: the on-site group and the digital group. The result of this pilot was a tested selective methodology that has been used for the collective research of the H-Buurt. The students divided themselves in four groups to use this methodology on the four different stakeholders

of the H-Buurt: the government, the makers, the owners and the users. Using a so-called code book, a universal language was formed to describe the results of the four separate research groups. Using this code book the different groups independently researched the Bijlmerplein, the Hoptille and the Heesterveld location on three different scale levels: the urban, the building and the detail level. The results of these four research groups resulted in an extensive collection of information that can be considered a toolkit for each of the individual graduation projects. The vertical bar on the right side of the scheme illustrates how each of the parts that make up the collective research contribute to the development of the personal research and interests.

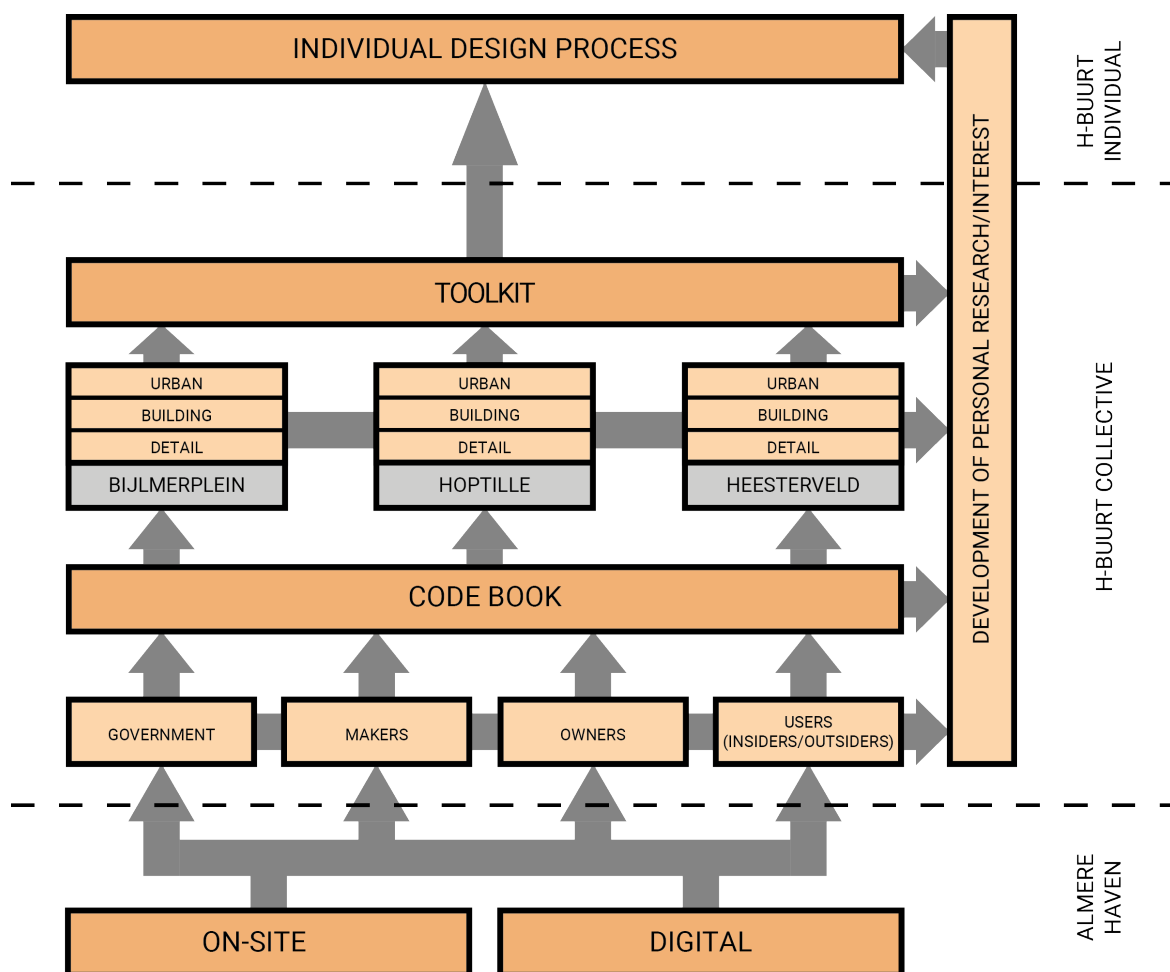

Figure 12. Collective code book scheme

Reflection on methodology

7.1 Methodology of the collective research

Almere Haven

The pilot research in Almere Haven is used as an experiment, before diving into the research in the H-Buurt. During this experiment, the goal is to test and adapt the research methods and to extract the attributes and values from the opinions of inhabitants. The pilot research consists of two approaches, a media one and an on-site one. After this pilot research, the methods were discussed and the best methods are used in the H-Buurt research.

Media

The first method being used in Almere Haven is the social media research. Several sources were being used for this method: Facebook, Instagram, Flickr and books about the vision. Hotspot maps were made to indicate the distribution of the locations where people took photos. Mind maps were made to provide information about the attributes at the various locations. Finally, a Sankey diagram is used to compare the different stakeholders and whether their values correspond or not.

On site

The second approach was on site. This involved street interviews of different kinds and several site visits. In total four different methods were used for the interviews: open conversation (A), drawings (B), pictures (C), and a questionnaire (D). Each method had its own goal and specifics.

Method A was used during the first site visit. The method is open and based on a conversation. Its goal was to gain a variety of information about the interviewees and their experiences, without leading them into specific directions. It was a suitable method to get a first impression

of Almere Haven. However, it also resulted in non-comparable data.

The other three methods were prepared for the second site visit. Method B is also open, but visual instead of textual. The goal here was to obtain information about personal, intuitive, and specific attributes and/or opinions.

Method C and D are more specific. Method C is also visual and aims to direct and acquire specific information within a framework (images) without influence of personal interpretation. Method D is textual again. The goal of this method is to obtain comparable information and opinions about specific subjects of the research (question).

An overview of the four methods is shown below:

	TEXTUAL	VISUAL
OPEN	OPEN CONVERSATION (A)	DRAWINGS (B)
SPECIFIED	QUESTIONNAIRE (D)	PICTURES (C)

Figure 13. Four methods Almere Haven Pilot

The data gathered using these methods was documented and analysed. The analysis consisted of colour coding the data in order to extract values, opportunities, and challenges (non-values). From these first interpretations of the data, different graphs and maps were made to summarise the results.

Translation to H-Buurt

In order to learn from the Almere Haven research, the group reflected on all methods used.

For the media group, there were a few methods that worked quite well for gaining quantitative data. The sources Facebook, Instagram and Flickr were most useful for the research. The

Reflection on methodology

hotspot and tag maps show where photos were being taken and which tags were used. This combination resulted in a quantitative study with a qualitative map as well.

The on-site group decided on a top four of the tested methods and a list of recommendations. For each method, the main goal was established. Each method has its own reflection. This reflection was not just focused on the execution of the method but also on the documentation and the first analysis of the data.

H-Buurt

To start the H-Buurt research, the group divided into four groups. Each was appointed a “maker” according to Howard (2003) in order to cover different perspectives in the area. The division was made as followed: users, owners, makers, and government.

In the second week after the group division one method was used by all groups: photo elicitation (Harper, 2002). Seven photos were selected and shown to all interviewees along with collective questions. These answers were then compared in week three. The fourth week was used to gather more in-depth information and/or the processing of the data.

The method for processing of the data was equal for all groups. The program Atlas.ti was used to code the data to be analysed later on. For coding, an inductive strategy is chosen. This approach requires reading the data and identifying codes throughout the process. It is not clear which codes will be included in the final code book beforehand. This ensures that the codes reflect the issues of importance from the interviewees, not the preconceived notions of the researchers (Hennink, 2020).

The specific method per subgroup is described below.

Government

The government group focused on the perspective of the government on the H-Buurt. This includes the municipality, the national service for cultural heritage, but also organizers on the neighbourhood scale. The research consists of two parts, both spread out over five weeks. The goal is to identify the values in the H-Buurt, from the perspective of the government.

The first part of this research is desk research. This provides an overview of the area, in the form of demographics and in the form of plans and policies. The demographics include topics such as income, population or migration background. Demographics reflect trends and how those trends developed over time. Through analysis of these statistics we can identify events and societal change (passive influences) and policy change (active influences).

Secondly, interviewing representatives from different government agencies contextualizes the desk research. The interviews are structured around a fixed set of photos.

Makers

The maker group looked into the makers and academics according to the table of Howard (2003). Makers are the original architects, urban planners and re-designers. Academics involved specialists from architectural heritage, urban and housing fields. The research was built up in several parts during five weeks to find out what attributes and values could be found from the maker and academic perspective.

Reflection on methodology

The first part consisted of site visiting, studying literature and other secondary resources to get familiar with the architecture and context of the Bijlmer initial idea until now. As a result a summarized text of the literature and a timeline were made to provide a comprehensive overview. The following step was preparing and having interviews with the architects and academics themselves to find out attributes and values of each of them. Therefore a set of pictures was shown to each of the interviewees to react on, followed by more in-depth questions about their project/specialty.

Owners

The owners group focused on the real estate property within the five neighbourhoods of H-Buurt. There were five steps within the research phase, which built upon each other and could be combined in one in-depth research on the attributes and values out of the owner's perspective.

The gained knowledge of week one enabled the group to set up interviews with the stakeholders themselves. Interviewees have been asked to bring photos of the neighbourhood and explain their personal relation to them. A short personal introduction was followed by six of the collectively picked photos of different areas within the H-Buurt. Goal was to get a personal reaction to the photos shown. Those reactions allowed to gather valuable information of possible owner related focus points.

Users

The users group focused on the perspective of the people who live or work in the H-Buurt or visit the H-Buurt for a different reason. The aim is to understand the attributes current users value, so these can be taken into consideration for future designs. For the research three

sources were used, which were approached in similar ways. Firstly, general research was done and secondly, more detailed information was gathered. Furthermore, all this research was coded and the data interpreted. Finally, conclusions were drawn and overviews of the information were made.

For the first source, interviews, four types of interviews were conducted. In the first week a basic set of questions was used to get a general idea of the opinions about the area. This information was used to create a more detailed set of questions and a collective set of photos, which were used for the online questionnaire in week two as well as the in-depth interviews. This photaset was simultaneously used for the street interviews.

For the second source, social media, information was gathered on Flickr, Instagram, and Facebook. The information consisted of pictures with hashtags and comments.

For the third source, research done by others, information was gathered from scientific sources on the users' perspectives specified to Bijlmerplein, Hoptille and Heesterveld.

7.2 Methodology of the individual research

The main focus in the individual research will be the interaction between the building analysis of the wall-like building of Hoptille and the analysis of own designs and existing architectural projects. In both types of analysis the topics discussed in the problem statement of this research plan will play an extensive role. However, due to the fact that this is a design studio that focusses around heritage, the technological building analysis will play a crucial role in this process as well. This technological analysis will be done on three

Reflection on methodology

levels as suggested by Frank Koopman, a 'Heritage & Technology' tutor on the TU Delft. Structure, materials and services are these three levels on which the building(s) will have to be analysed.

As the problem statement is directed towards social aspects the first of these levels, structure, will play the biggest role in the analysis. The reason being that the structure of a building has the biggest impact on its spatial qualities. These impacts are directly affecting the physical and visual connections, that both play a big role in the social qualities of a building, within the plot. The materiality of this analysis follows as the second most important as this will directly affect the identity of the building(s).

Themes for analysis

Within the collective research fourteen themes (excluding the sub-themes) were detected for the H-Buurt. Using these themes, comparisons between the different stakeholder groups could be made. In regards to this personal research a selection of these themes are used to digest the findings on these different themes. The themes that set up this selection are the following:

1. Diversity
 - a. in Public Space
 - b. in Dwelling scale
 - c. in Function
 - d. Cultural
2. Feeling of Safety
3. (In)formal economy
4. Lack of qualitative greenery
5. Low – mid – high-rise
6. Maintenance
 - a. Building
 - b. Urban
7. Mistrust
8. Sense of ownership
9. Three distinctive identities
10. Unintended use of public space

The ten selected themes all have something to do with the discussed issues of identity and community that are addressed in the problem statement. As the individual challenge of this design studio is set to improve on the social functioning and the enhancing of the existing identity of Hoptille the 'users' stakeholder is most important. The other three stakeholders, the makers, government and the owners, do however provide different perspectives on the variety of topics.

Reflection on methodology

Explorations

After gaining a thorough understanding, gained by technical and thematic building analysis, of the wall-like building of Hoptille architectural explorations will be possible. The method for doing these explorations are both physical as digital since both of these offer different benefits. Physical explorations, such as drawings or the making of physical sketch models, are particularly useful in the early stages of designing. Reason for this is the speed in which mental images can be captured and evaluated. The biggest benefit of doing digital architectural explorations for me is the ability to change the perspective and scale of the drawing at any point. This flexibility allows for the maker and others to evaluate the spatial explorations in an effective way. Since both of these methods hold their own benefits an alteration of these methods will be used. By going back and forth between the methods the explorative process will be kept up to speed but also result in models that can be analysed on different scales and for different themes.

Concepts

Once an exploration starts to take shape as an architectural model it can be evaluated as a concept more specifically. An exploration will be seen as a concept once it is at least drawn out schematically in a site plan, floor plan and section or once a 3D-model has been made that covers all of these drawings. With a concept done a reflection to the problem statement can be made in detail, this can result in a variety of scenario's: the concept is fundamentally wrong and a new exploration needs to be made, the concept meets a majority of the requirements but still lacks in one or several parts, or, the concept meets the requirements and can be further worked out into the design proposal. In case of the second result new explorations need

to be made, these can be several explorations based upon the exploration that was used to create the current concept.

The requirements

The requirements that have to be met are directly related to the problem statement and can be shortly formulated as follows:

- The identity of the concept is supported by the heritage values that were determined during the collective research of the Hoptille area.
- The small scale identity provided by the low-rise buildings of Hoptille is preserved.
- The identity of the Hoptille area will be greener than the current situation.
- The visibility for the inhabitants to one another and to the street will be improved.
- The concept offers housing for a high variety of people and types of households.
- The concept will offer accessibility for people with limited mobility.

Individual research structure

8 Individual research structure

The research structure is made in order to form a clear direction to the research and design process. In this case the end product will have to be a well-argued design proposal for the mid-rise Hoptille building. As shown in figure 3 the structure is divided into three rows: literature, context and design. By placing the context, the Hoptille area and its current situation, in the middle of this structure it is secured that the research is done site specific and does not become too general. Just as how the problem statement is divided into the two topics of community and identity so is the

theoretical framework of my research. Both of these topics have three sub-topics that are always related to one of the two main topics. If this literature can help with the understanding of the flaws in the current situation of Hoptille it will be part of the problem statement. When this is the case the row of design in this diagram will be applicable. By analysing the current building, the collective research and the literature that forms the problem statement it will be possible to start the process of research by design. The method for the research by design has been elaborated in the previous chapter under the 'Methodology of the individual research'.

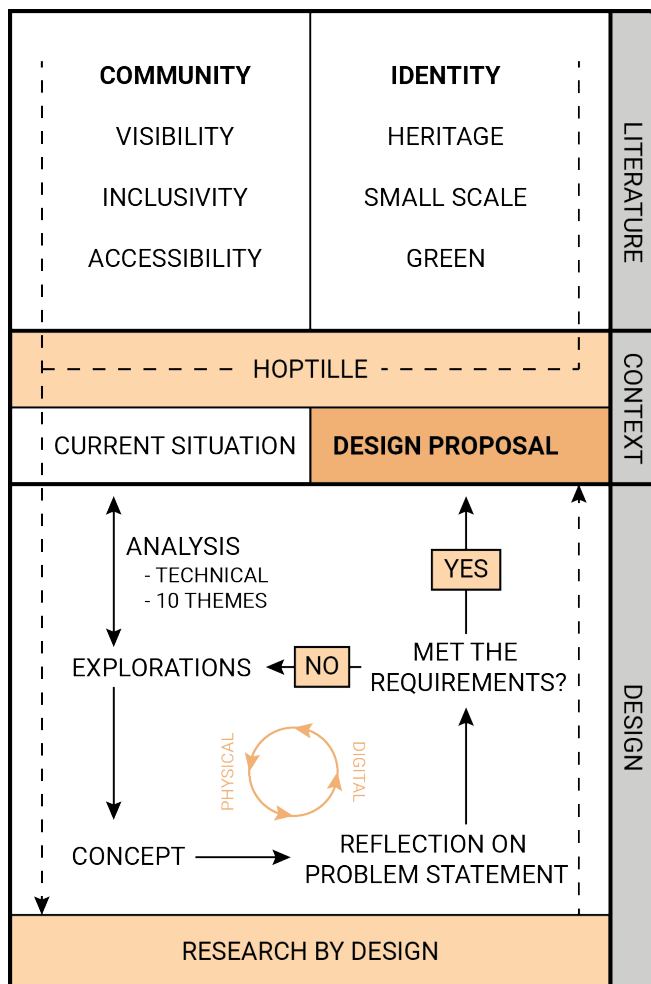

Figure 14. Diagram research structure

Objective

9 Objective

Due to the problematics of the corridor in the long building of Hoptille right after construction, the choice was made to get rid of this part of the design completely. A very limited social control on the space resulted in the space being used by gangs to perform criminal activities. Only two years after the construction of Hoptille the corridor was removed and an external housing access was added on the building. As a result of the research that was done as a group in this design studio, we found that social problems

are sadly still present in the building. On top of that, it has become clear that the staircases and steel stairs have only given the building more social issues. Even though the unsafe corridor was gone the social issues remained. Therefore, the decision was made to look into the option of bringing back the corridor but modifying it in such a way that it would improve the social functioning of the building.

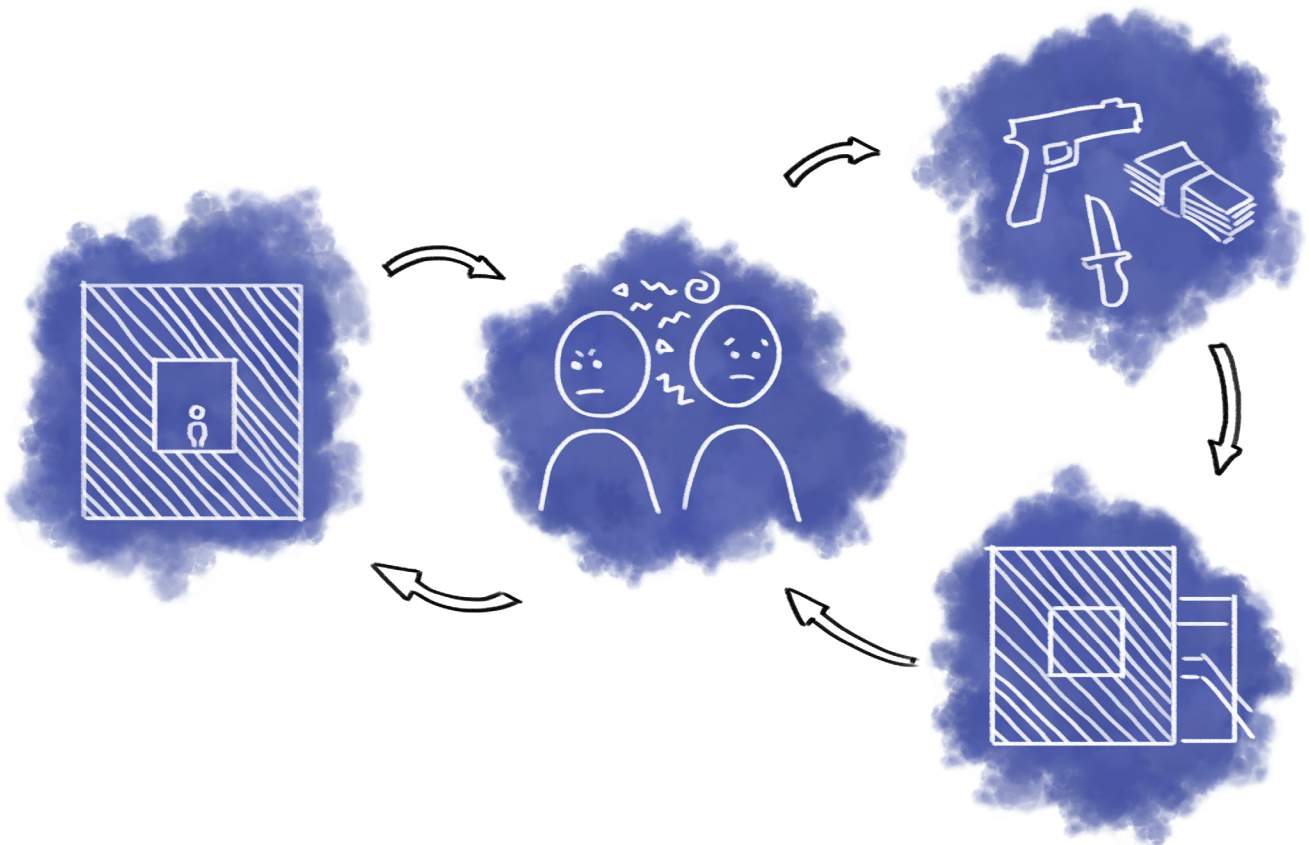

Figure 15. Objective diagram

Value assessment of interventions

10 Value assessment of interventions

The interventions that have been made in order to transform the long building of Hoptille can be categorized in six parts: the reintroduction of a corridor, the addition of the glasshouse, the changes to the south-west and the north-east facade, the rearrangement of the public space, and the connection of east to west with the new passages.

Value assessments were made for each of these six interventions. Based on eight different types of values each intervention was graded using a point system that ranged from a minus three to a positive three. To make sure that I personally would not be biased in making these assessments out of one perspective this was done together with two other students.

By combining the values of each of the interventions together and dividing these values by six a final spider diagram could be made. This final diagram shows that that, apart from

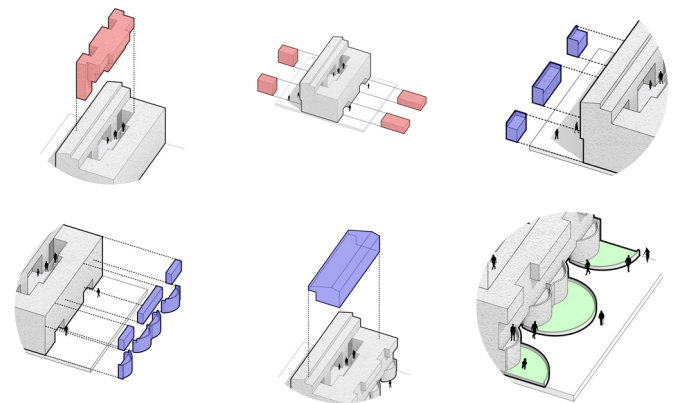

Figure 16. Six interventions

the commemorative and the historical values, each value improves. This outcome gave the motivation to design the new elements in such a way that they would draw more attention to the historical and commemorative values of the building. In the end this was done by over exaggerating the circular elements that were present in the current building.

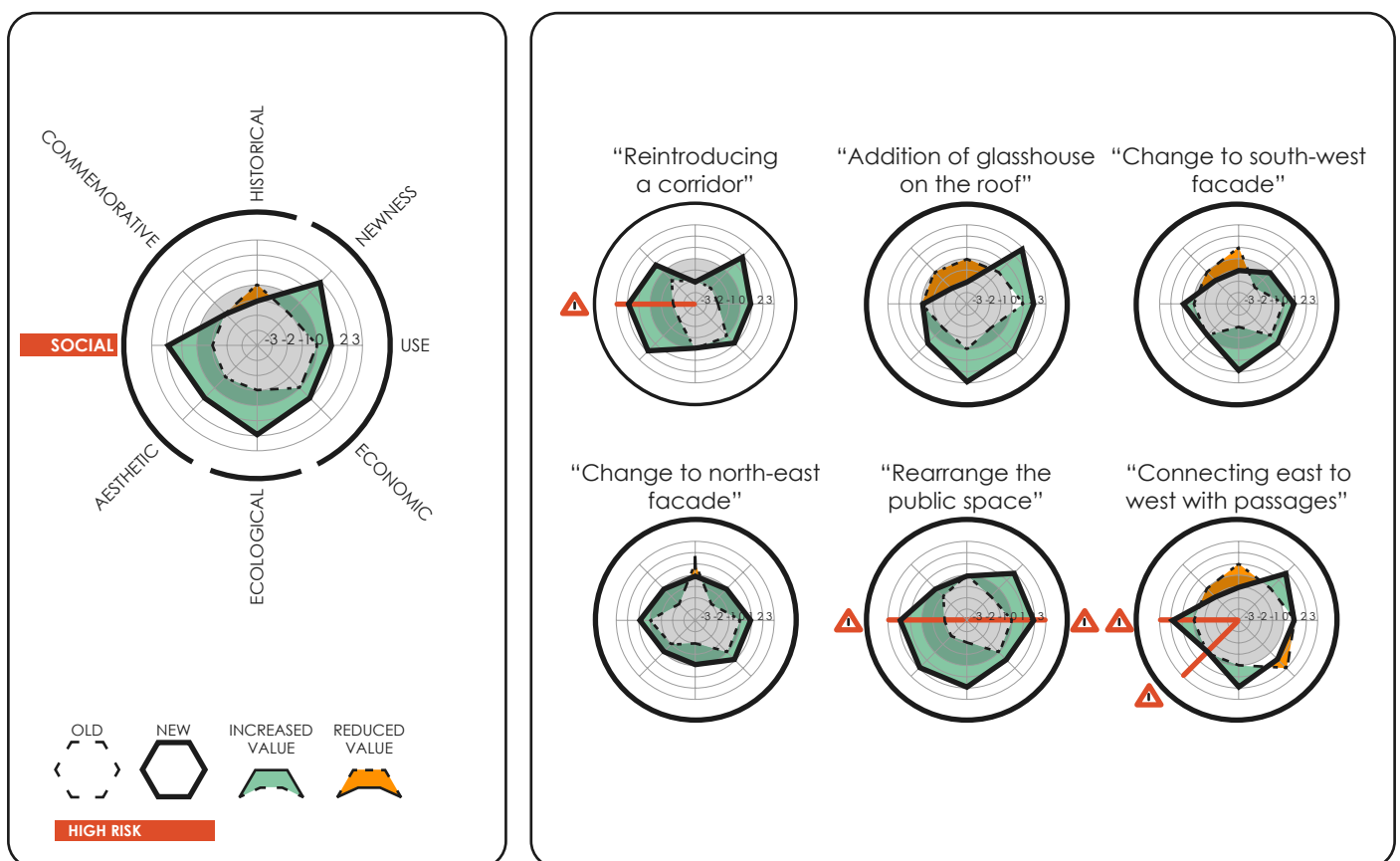

Figure 17. Value assessment

Spatial explorations

11 Spatial explorations

Since the addition of the corridor is meant to solve the main issues that are present in the building a lot of digital spatial explorations have been done to design this specific space. The main goal of designing this new corridor space has been to form a space that feels open, that is functional but also indicates that this space can still be seen as part of the public space.

Whilst designing, I experimented with adding angled walls but ended up using a shape that used straight walls with setbacks to form balconies. By doing so the balconies will help with the neighbour engagement that could happen inside of the corridor.

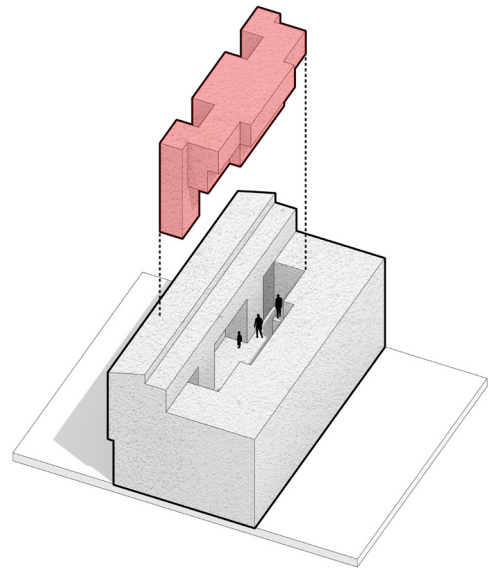

Figure 18. Carved out volume

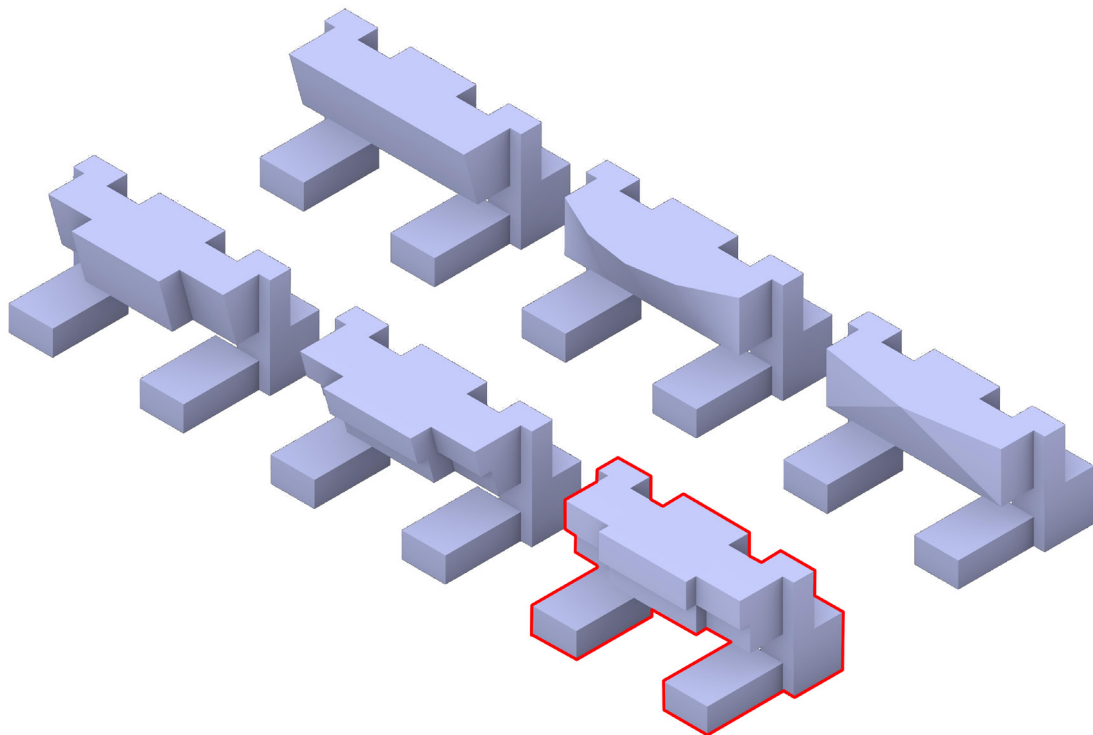

Figure 19. Spatial explorations

Reintroducing a corridor

12 Reintroducing a corridor

The new corridor that will be introduced to the building will be much smaller in length than the original corridor that ran through the entire building block. In the transformation there will be eleven smaller corridors that give access to 26 dwellings. By doing so these new corridors will be much easier to manage for the housing corporation.

As the upper floor of the corridor has set backs and the roof is much higher up with the addition of the glasshouse an outdoor feel is given to this space. Natural lighting, greenery and materiality will give this space the character of something right in between public and private marking this space as a transition zone.

The frames concept that will be explained later in this report allows the inhabitants to shape this corridor. By doing so the space will become more personal to the inhabitants.

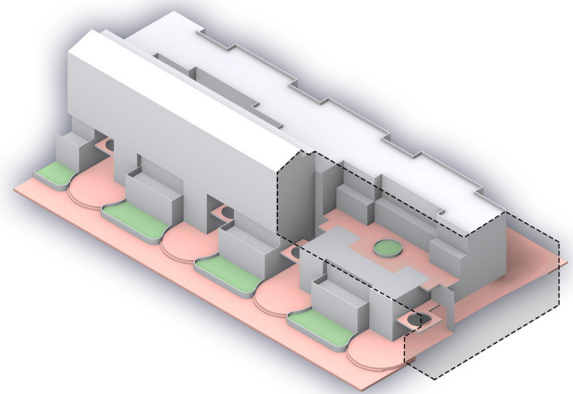

Figure 20. Corridor, isometric

The facade material of this new corridor will mainly be wood panels with circular perforations. These perforations make sure that there will be less sound bouncing off of these panels to make sure that the sound quality inside of these corridors will be comfortable.



Figure 21. Render, corridor

Addition of a glasshouse on the roof

13 Addition of a glasshouse on the roof

To control the air and temperature of the space inside of the corridor a glasshouse is added for each of the corridors. This glasshouse has several operable parts and integrated solar panels. The climate system that this glasshouse offers to the building is explained in the climate drawings that can be found in the presentation file on the repository.

Apart from the climate properties the glasshouse gives to the project, it also offers a space for gardening to the apartments that go up to the top floor. The gardening space is shared between the apartments on top so that the inhabitants can visit one another through this space as well as offer help with gardening.

The steel construction that forms the outline of the glasshouse follows the angle of the angled roof of existing building until it reaches the middle of the block where this angle flips to the

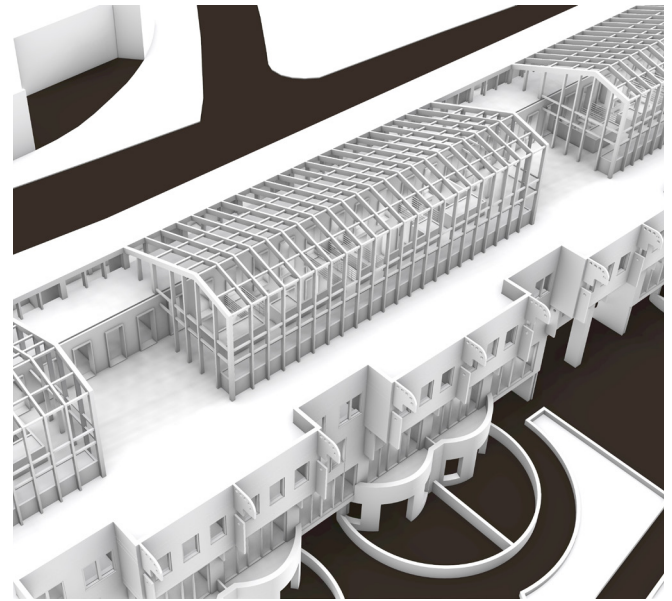

Figure 22. 3D, glasshouse

other side of the block. From the south-west side of the building the glasshouse is barely visible because of this in order to preserve the small scale identity of the low-rise blocks here.



Figure 23. Render, glasshouse

Change to north-east facade

14.1 Change to north-east facade

The changes for this side of the facade start by removing all of the attachments that were made after the building was finished originally. The big staircase volumes, the steel staircases and the steel walkway attached to the building will all be removed. All of the original windows will also be replaced by new aluminium frames with double glazing as the original windows were giving too many technical issues.

New additions have been made in the form of rectangular volumes made of timber. These add floorspace to the apartments and add a terrace on the first floor allowing for some extra social control over the public space in front of the building.

Gardens are also added in front of these new volumes. This pushes the public flow even further away of the building allowing for more privacy in the apartments and allowing the



Figure 24. Render, entrance corridor

public space to gradually transition from public to private.



Change to south-west facade

14.2 Change to south-west facade

On the south-west side of the facade more new volumes are added. These timber additions are placed exactly there where there used to be the rectangular as the rounded balconies. By doing so the rhythm of the original facade is maintained whilst adding extra floorspace to the building.

The parts that replace the rounded balconies on the ground floor curve down further into the facade. By doing so the shape guides people back into the passages that lead to the corridor or other side of the building.

Most of the concrete slab elements have been replaced onto the facade. Instead of being part of the balcony design, they now have a commemorative purpose reminding the people of what the building used to be.

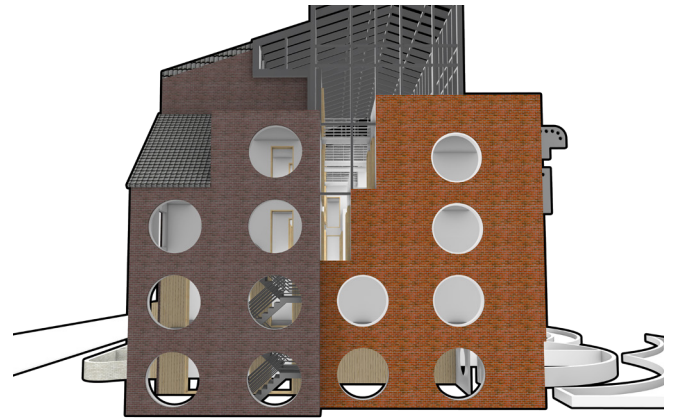

14.3 Change to side facades

Both sides of the long volume were also changed in the transformation. The brickworks from both sides of the facade come together and large circular perforations have been added to draw attention to the 80's architectural elements of the building.



Rearrange the public space

15 Rearrange the public space

The public space on the south-west side of the building is changed completely. Following the circular shapes of the new gardens on this side of the block the new public space is no longer a space for people to move from A to B. The new vision for this area is for it to be a place where the inhabitants of the area can wander around, have a chat with one of their neighbours or just

to get some fresh air. The zones are carefully planned out in such a way that all of the trees that are present in the current situation can remain where they are. By cutting up the green spaces each of them can be given different foliage in order to stimulate the bio diversity.

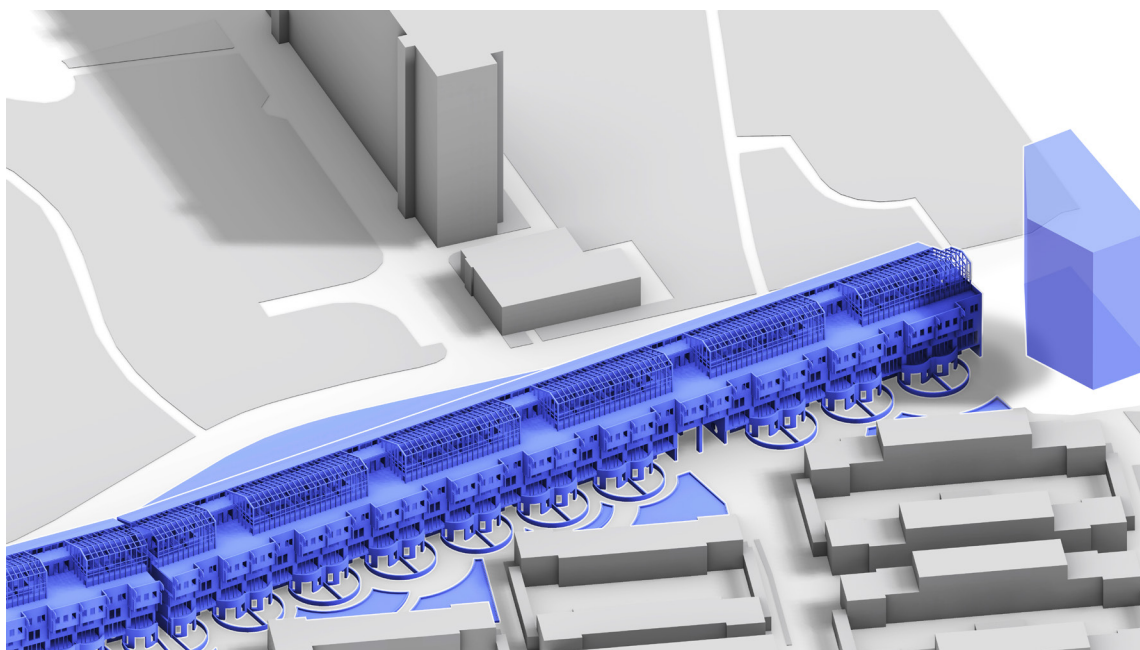
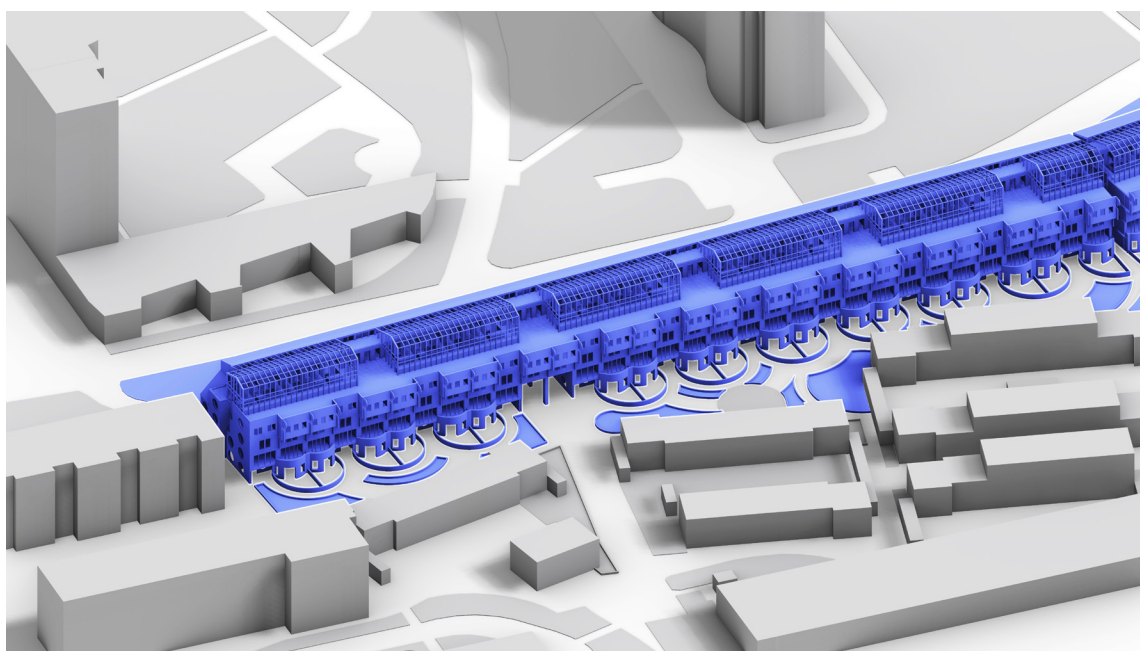

Connecting east to west with passages

16 Connecting east to west with passages

By taking out volumes on both sides of the building block new passages will be formed to connect both sides of the building together as well as to gain access to the new corridor space. Since the structural elements do not line up, the spaces that are formed have more volume next to the straight path that can be walked on to go from the north-east to the south-west side. The extra volume that this has created on the south-west side of the facade will be used as a bike storage. On the north-east side of the building the first level will also be included in order to make sure that no part of the staircases to the corridor are closed off.

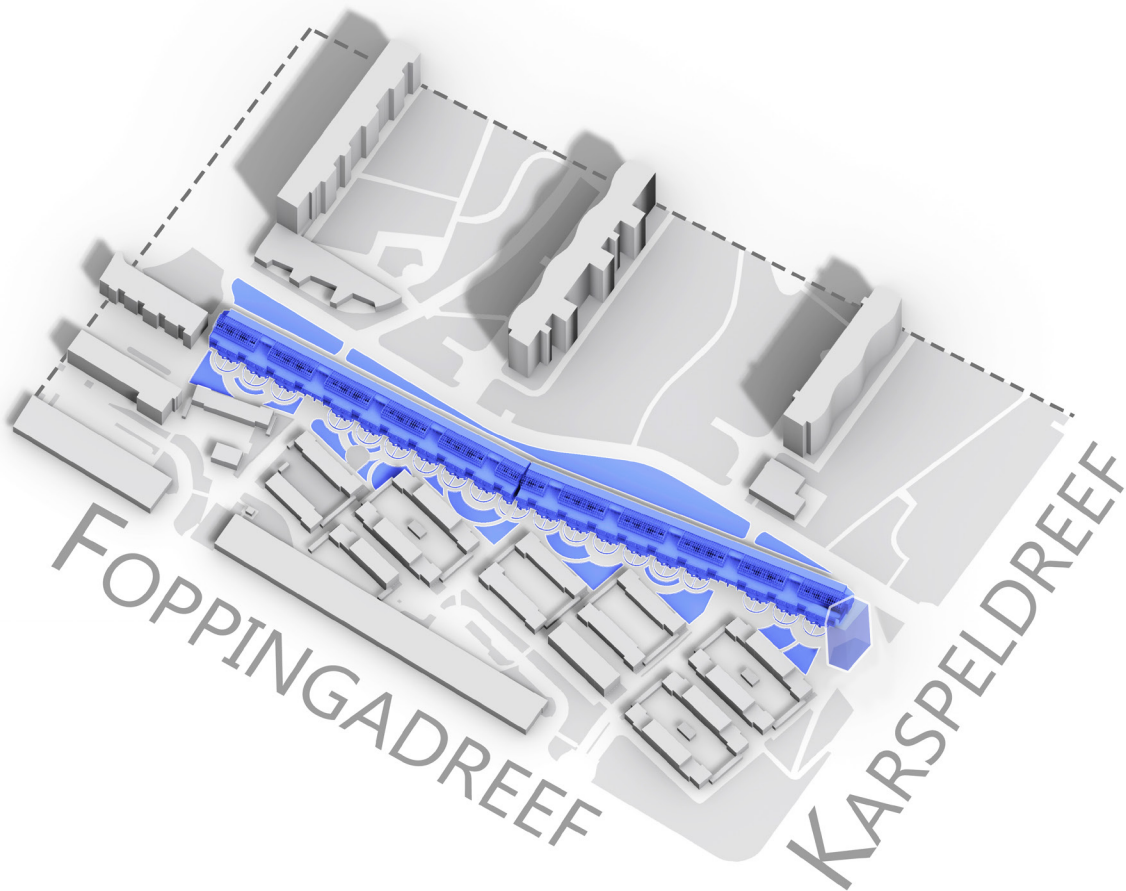
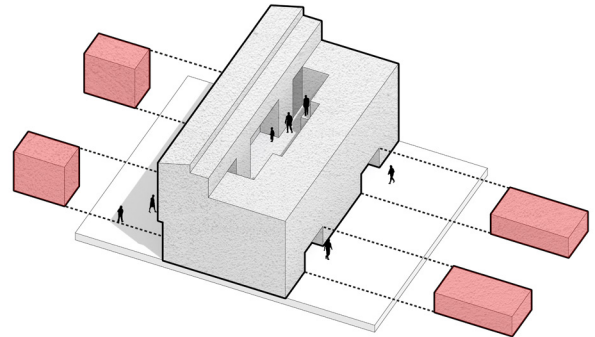

Flexibility concepts

17 Modular additions

The final addition that was made to the building is all about flexibility and identity. To make sure that people will want to live in their apartments for a longer period of time I personally believe that giving people options can be very beneficial. What people put inside of their apartments is of course already up to them, but by making people also have a choice over the architectural

parts of their apartment I believe they will feel more attached to them. Therefore, the doors and windows shown underneath have been designed that fit within one easily demountable system. Together the modular and circular kitchens project by TheNewMakers that Ymere Commissioned these concepts will be placed in the project.

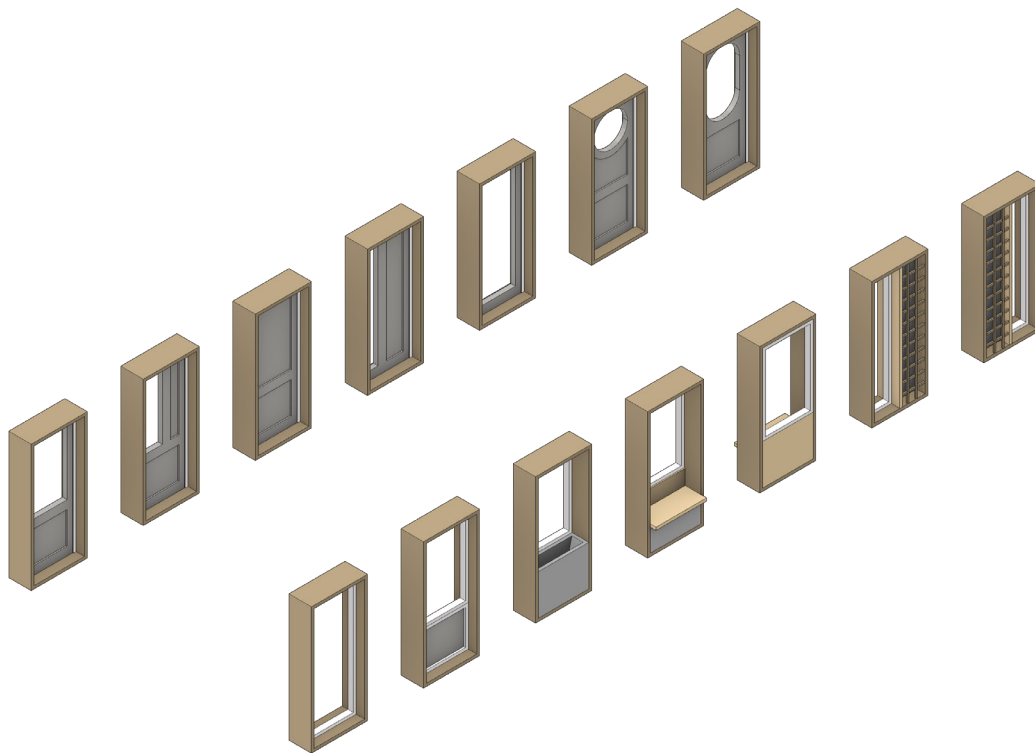

Figure 3. Circular kitchen. From “The-NewMakers,” 2019 (<https://www.thenewmakers.com/2019/09/24/circulaire-keuken-ymere/>)

Bibliography

18. Bibliography

18.1 Literature

Brooklyn. *Space and Culture*, 8(4), 459-471.

Gehl, J. (2011). *Life Between Buildings Using Public Space*. Island Press.

Harper, D. (2002). Talking about pictures: A case for photo elicitation. *Visual studies*, 17(1), 13-26.

Hennink, M., Hutter, I., & Bailey, A. (2020a). In-depth interview. In *Qualitative research methods* (p. 108-131). SAGE Publications Limited

Hennink, M., Hutter, I., & Bailey, A. (2020b). Data Preparation and Developing Codes. In *Qualitative research methods* (p. 207-234). SAGE Publications Limited.

Howard, P. (2003). *Heritage Management, Interpretation, Identity*. Continuum.

Vaeztavakoli, A., Lak, A., & Yigitcanlar, T. (2018). Blue and Green Spaces as Therapeutic Landscapes: Health Effects of Urban Water Canal Areas of Isfahan. *Sustainability*, 10:4010, 16

Wickersham, J. (2001). Jane Jacob's Critique of Zoning: From Euclid to Portland and Beyond. *Boston College Environmental Affairs Law Review*(28:547), 550-552

18.2 Own research

Volunteer De Handreiking (2020). Interview conducted by Marije de Ruijter & Stefan Lichtenveldt (of the users group)

Sjoerd Soeters (2020). Interview conducted by Rolf Oosterhuis, Nurhadi Nugraha, Karry Li and Martinas Sacevičius (makers group)

Government group (2020). Collective research done by Thijs Blom, Jonathan Verhoef and Rebwar Obeid

Interviews users group (2020). Street interviews conducted by Sophie Vrisekoop, Cornee Louwerens, Min Ju Cha, Yuting Hu, Julie Megens, Marije de Ruijter & Stefan Lichtenveldt (users group)