

“Designing a robust supply chain for military operations”

A multi agent simulation approach
considering truck platooning



Koninklijke Landmacht



Designing a Robust Supply Chain for Military operations

A Multi-Agent Simulation approach considering Platooning

by

B.H.T. Reinders

to obtain the degree of Master of Science
at the Delft University of Technology,
to be defended publicly on Wednesday December 11, 2019 at 14:00.



Koninklijke Landmacht

Student number:	4065085	
Report number:	2019.TEL.8381	
Project duration:	April 1st, 2019 – December 11th, 2019	
Thesis committee:	Prof. dr. ir. R. R. Negenborn	TU Delft, 3ME, Chair
	Prof. dr. ir. P. H. A. J. M. van Gelder	TU Delft, TBM
	Dr. F. Schulte,	TU Delft, 3ME, Supervisor
Company supervisor	Maj. A. F. P. de Wit,	Department of Defense, Supervisor

This thesis is confidential and cannot be made public until December 31, 2020.

An electronic version of this thesis is available at <http://repository.tudelft.nl/>.



Abstract

Supply chains are to be found in almost every corporation around the world. When trying to manage a supply chain often two types of disturbance can jeopardize the effectiveness of a supply chain. These are supply and demand uncertainty. This thesis tries to investigate the effects of those two types of disturbances in a supply chain and seeks to find a remedy. When taking a closer look at supply chains, robust supply chains are considered to withstand a higher level of supply and demand uncertainty. Robustness knows many definitions but is mostly characterized by the responsiveness and adaptability of a supply chain. Responsiveness implies a degree of quick reaction to sudden changes, while adaptability is defined as the capacity to deal with new circumstances. This thesis tries to relate robustness according to a level of resistance of supply and demand uncertainties. The supply chain of the royal dutch land forces is prone to such sudden changes. Therefore this research incorporates the context of a military supply chain to perform experiments on. The military supply chain in operational areas is selected and identified as a 3-echelon-multiple tier-supply chain, where the implementation of a networked supply chain can result in an increase in robustness. The research uses three key performance indicators to "measure" a degree of robustness. With the use of a multi-agent discrete-event model that incorporates a highly dynamic environment including real-time transportation and order handling simulations. The model also contains an integer supply optimization module using CPLEX and a distance-based swarming algorithm to emulate the lifelike situation of the supply chain concerning order handling and "Notice to move". Three experimental setups have been created that try to quantify robustness levels according to networked supply chain operations while coping with demand and supply uncertainty. First, a sensitivity analysis is performed, revealing the basic relationships between the indicator and demand/supply fluctuation. Second, an extensive model testing according to three different load cases in uncertainty is performed. Thirdly a case study specified for a military context is done. It is found that robustness can be increased by increasing the amount of networked forward supply nodes and interesting dependencies are revealed between the amount of forward supply centers and robustness. The findings of this research can be applied to other industries that have a similar supply chain design.

Preface

In the past 40 years, the way of combat has drastically changed, large scale warfare with clear distinct enemies changed into more local smaller battles, where foe or friend are hard to distinguish. Instead of large fronts, smaller "swarms" of tailor-made combat units are introduced. New weaponry systems have been developed, replacing the ordinary rifle with more advanced and even autonomous systems. Missiles, artillery and heavy support weapons gained an increase in impact and range. Besides this development, new threats developed due to political, economic and environmental changes, resulting in an increase of world tension.

Although the scales of battle might not be as big as before, a more dispersed behavior is observed that includes rapid maneuvers that need to be supported. These maneuvers stretch troops thin about many miles, under suspicious circumstances of intense threats. This demands an adaptive, tailor-made supply chain to pursue the goal of supply combat units. When taking this into account combined with the increase ranges of impacts of hostile support weaponry, the supply chain seems an easy and alluring target. Ground operations rise or fall with the level of performance of a supply chain. Keeping units well supplied increases the odds of gaining the upper hand in a conflict. That's why the department of defense invests a lot of effort into researching further innovations that benefit the supply chain.

At this part, I'm convinced that with the help of a well supported and decent model more insight can be given into the requirements of a robust supply chain. Many commercial supply chains have already been converted into a wide variety of models, resulting in good insights. Since the supply chain of the Royal Dutch Land Forces resembles those of big corporations, I think there is a lot to gain in such research.

Currently, there is a supply chain model when performing operational logistics, a concept named physic distribution, that is created some years ago. However, the department wants to implement a new concept. This concept might be more robust and resilient, however, before implementation, this concept needs to be mapped out and explored a bit further. This thesis tries to do this by means of a simulation.

*B.H.T. Reinders
Delft, November 2019*

Acknowledgements

This thesis does not just mean the end of a research period. It is a milestone that marks an important decade of my life, full of experiences, good memory and less fortunate moments. However, I would not have been able to reach this moment without the help of some important people.

First I would like to thank Frederik Schulte, with whom I have been cooperating since my literature assignment earlier this year and due to pleasant collaboration did ask to guide me through the graduation project. Frederik, many thanks for your advice about my graduation research and for the confidence in finalizing this research, even though there were some moments where I didn't think I would manage. Your calm and structured manner of outlining large problems was a great help for me to grasp back control in this research. I can definitely say that I enjoyed the collaboration to this day.

Further, I want to thank Nout de Wit, for showing me around in the great, and sometimes a bit bureaucratic, world of the Royal Dutch Land Forces. The weekly visits to the barracks of Soesterberg definitely aided in creating this thesis. Nout, thank you for introducing me to the OTC-LOG kenniscentrum, it was productive as well as pleasant to talk to you and your colleagues, who were all willing to share some of their knowledge and experiences. Also thank you for being closely involved in my research and answering all my questions in no time, making you a great supervisor.

Also, I would like to thank prof. Negenborn for the in-between reviews of the project. After the reviews, many new objectives were set, aiding me in further improving the research and giving guidance during the project.

The major part of my graduation project, that cannot be seen in this thesis, was the modeling process. As will be explained further in this thesis, I decided to go with a modeling package called 'Salabim'. Since I have little knowledge of modeling and working with open source languages, a lot of support was needed. Therefore I want to express my greatest appreciation via this way to Ruud van der Ham, the core developer of Salabim, who was willing to answer all my questions along the way of developing the model. Ruud, many thanks for almost instantly answering my infinite stream of questions about Salabim and for looking for ways to optimize my model. Your support gave me the confidence to advance the model, and my programming skills, into a higher level.

Then I would like to express my appreciation regarding Suzanne who was willing to read through the thesis and give some valuable advice regarding the research project itself. As a former TEL student at the faculty of Mechanical Engineering your views and pieces of advice concerning the project were most welcome and valuable. Also, I want to thank you as well for bringing the bright and fun moments during the graduation project that gave me the needed relaxation and ability to relativize during this long-lasting project.

Also, a word of thanks is deserved for all my friends in Delft and the Hague, including roommates, the new and old and other students of my master track with whom I met regularly. At last, but definitely not least, I want to thank three people that might not have been involved in the actual realization of this thesis, but cannot be forgotten. I would like to thank my parents and sister for their everlasting confidence in my academic journey and constant support. Thank you for giving me this opportunity for studying at this university, since it was a completely new experience for all of us. Henk, Carla and Lyan thank you for letting me leave the comforts of the south of the Netherlands and let me experience Delft at its fullest.

Contents

List of Tables	ix
List of Figures	xi
1 Introduction	1
1.1 Context of the research and Knowledge Gap	1
1.1.1 Context	1
1.1.2 Knowledge gab	3
1.2 Scope and Objectives	3
1.3 Research Question	4
1.4 Approach	4
1.5 Further Lay-out of the Report	5
2 Literature study	7
2.1 Introduction	7
2.2 Main Topics	7
2.2.1 Supply Chains	8
2.2.2 Modeling and Simulation	14
2.2.3 Truck Platooning	17
2.2.4 Multi-Agent Systems	18
2.3 Conclusion	20
3 The Military Supply Chain	23
3.1 Introduction	23
3.2 The Generic Supply Chain Design.	23
3.2.1 National Displacement	24
3.2.2 Strategic Displacement.	25
3.2.3 Operational Displacement & Tactical Displacement	25
3.2.4 Means of Transportation	27
3.2.5 Supplies of the Royal Dutch Land Forces	30
3.2.6 Delivery Methods	33
3.3 Conclusion	34
4 Truck Transport during Military Operations	37
4.1 Introduction	37
4.2 Convoy Styles	37
4.3 Truck Platooning	39
4.4 Integration of Platooning in Military Context.	39
4.5 Conclusion	40
5 System Analysis and Simulation	41
5.1 Introduction	41
5.2 Systems Approach	41
5.3 Modeling Process and Development	43
5.3.1 Model Challenges and Language selection	45
5.3.2 Model Assumptions	46
5.4 Conclusion	47

6	The Simulation Model	49
6.1	Introduction	49
6.2	Model Performance and Robustness Objectives	49
6.3	Supply Optimization and "Notice to Move" Models	50
6.3.1	Supply Optimization model.	50
6.3.2	Distance-based Swarming for Forward Supply Centres	51
6.4	Classes	52
6.5	Processes and Flows.	54
6.5.1	Information Flow	54
6.5.2	Supply Flow.	55
6.5.3	Truck Flow	55
6.5.4	Flows combined	56
6.6	Model Variables.	56
6.6.1	Design Configurations	57
6.6.2	Scenario Configurations	58
6.6.3	Fluctuation of Demand	58
6.6.4	Link Drop-out	58
6.6.5	Node Drop-out	59
6.7	Sample Size	59
6.8	Validation and Verification	60
6.9	Conclusion	61
7	Numerical Experiments	65
7.1	Introduction	65
7.2	Experimental Setups	65
7.2.1	Total Amount of Experiments	65
7.2.2	Sensitivity Analysis	65
7.2.3	Load Cases	66
7.2.4	Case Study - A military operation near Mszanka	67
7.3	Results	69
7.3.1	Sensitivity Analysis	69
7.3.2	Load Cases	72
7.3.3	Case Study - A military operation near Mszanka	77
7.4	Conclusion	81
8	Findings and Insights	83
8.1	Sensitivity Findings	83
8.2	Load case findings	84
8.3	Case study findings	85
8.4	Summary Robust Supply Chain	86
8.5	Summary for Platooning	87
9	Conclusion	89
10	Recommendations	91
	Bibliography	93

List of Tables

3.1	Table with specification of the Scania 165 kN WLS.	30
3.2	Table of 2 types of pallet sizes	30
3.3	Table of quantities, subscripts and units involved in calculation of days of supply.	30
3.4	Table of sub- and superscripts used for truck usage calculations.	31
3.5	Table containing staff planning data about weight and volume per supply class per PAX.	33
3.6	A brief overview of entities in the SC of the Royal Dutch Land Forces. A small description of its main function and constraints are explained.	36
4.1	Table showing quantities and units involved in calculation of convoys	38
4.2	Table showing subscript used in convoy speed calculations.	38
6.1	Table of overview of key performance indicators	49
6.2	Table of agents implemented in the model, including description, functionalities, and physical characteristics	54
6.3	Table of intensity factors used to calculate consumption rates.	59
7.1	Intensity factors and drop-out rates for Duty Classes	67
7.2	Table giving overview of intensity factors for demand fluctuations at unit level, specialized for the case study.	69
7.3	Table containing all mean values of supply stock levels during load case testing	76
7.4	Table containing all mean values of order fulfillment levels during load case testing.	76
7.5	Table containing mean values of lead time during load case experimenting	77
7.6	Table showing the overall, relative robustness increase.	77
7.7	Table presenting results of the case study of the 1-n-3-design configurations. The mean value is given next to the median value.	81
7.8	Case study: Relative improvements due to platooning.	81

List of Figures

1.1	Fysieke distributie model, the current way of supplying from homebase up to combat areas.	2
2.1	Representation of information availability versus availability of inventory [25].	9
2.2	Illustration of a decoupling point and some characteristics [17].	10
2.3	Representation of the control strategies and general simulator interaction.	13
2.4	A representation of the model to be created for this research, already considered by Dubiel [27].	16
2.5	A schematic representation of an example of truck platooning [23].	17
3.1	Generic supply chain of the Royal Dutch Land Forces.	24
3.2	Image of a representation of each displacements section in magnitude of displacement and level of detail.	24
3.3	A figure of the current supply chain design at operational and tactical level of the Department of Defence (DoD).	26
3.4	A figure of the conceptual supply chain design at operational and tactical level of the DoD.	27
3.5	Image of 2 possible load-out combinations of one level stacked flatracks. This configuration shows flatrack load-out with possible workspace.	28
3.6	Figure of truck equipped with WLS handling a container unit.	29
3.7	Figure of a truck equipped with a Wissel-Laad-Systeem (WLS), handling a container unit.	29
3.8	Figure of a truck equipped with WLS and Trekker-opleg-combinatie (TROPKO), used for heavy equipment transport.	29
3.9	Figure of the different stock level indicators of supply. The actual volume differs per unit size, so no standard amount can be specified in this figure without knowing what unit is deployed.	31
3.10	Figure of a schematic drawing of a deployed Supply street	34
4.1	Generic design of a convoy. Source: global security.org	38
5.1	Images of representations of the black box model.	42
5.2	Figure of the black box model complemented with some further information.	42
5.3	Figure of an expanded view of the transport function box and order control.	43
5.4	Figures of 2 fully expanded processes of the supply chain of the DoD.	44
5.5	The process of modeling and simulation.	45
6.1	The flow chart of information in the supply chain	55
6.2	The flow chart of supplies in the supply chain	55
6.3	The flow chart of truck movement in the supply chain, the circularity can be seen clearly	55
6.4	The combination of all 3 separate flows are displayed here in one complete overview.	56
6.5	Image of a representation of all possible variables during experiments in this research.	57
6.6	A generic model of a 4 echelon multiple tier supply system [43].	57
6.7	A comparison between the simplest and most complex design configuration. The simplest exists out of 3 echelons, single tiers configuration. the most complex has 2 Supply Centre (SC)s, 5 Forward Supply Centre (FSC)s and 2 Units.	58

6.8	Figure of the graph to determine the sample size.	60
6.9	Several images of the simulation screen, showing important events and information during an experiment.	63
6.10	Two images of link and node drops	64
7.1	Figure of the 3 different model design configurations that endure the sensitivity analysis.	66
7.2	Figure of the simplest and most complex design configurations during the load case experiments. All model in between those 2 examples are also involved. . .	66
7.3	Image of a representation of the design with the minimum amount of FSCs and maximum amount of FSCs	68
7.4	The area of interest for this case study, concerning eastern Europe within the red rectangle.	68
7.5	Overall information about the location chosen for this case study.	68
7.6	Two figures containing the sensitivity analysis information about the stock levels of three different designs.	70
7.7	Two figures containing the sensitivity analysis information about the order fulfillment percentages of three different designs.	71
7.8	Two figures containing the sensitivity analysis information about the lead time of three different designs.	72
7.9	Figures containing information about stock levels during separate load case tests	73
7.10	Figures containing information about order fulfillment during separate load case tests	74
7.11	Figures containing information about lead times during separate load case tests	75
7.12	Graphs containing information about supply levels versus the amount of FSCs	78
7.13	Graphs containing information about order fulfillment versus the amount of FSCs	79
7.14	Graphs containing information about lead times versus the amount of FSCs . .	80
8.1	Figure of lead times put on a linear scale of link drop and node drop inter arrival time. Clearly shows the relation between inter arrival time and lead times of a 1-1-1-Design.	85

Acronyms

ABM	Agent-Based Modeling	15
ABS	Agent-Based Simulation	15
ASV	Additional stock	25
BG	Battle Group	25
CACC	cooperative adaptive cruise control	17
CSC	Convoy Support Centre	25
DEM	Discrete Event Model	15
DES	Discrete Event Simulation	8
DoD	Department of Defence	xi
DoS	Days of Supply	26
FSC	Forward Supply Centre	xi
KPI	key performance indicator	5
MAS	Multi-Agent Systems	8
OBM	Object-Based Modeling	14
PEO	Peace Enforcement Operations	2
PSO	Peace Support Operations	2
PAX	Person(s)	31
POD	Point of disembarkation	3
POE	Poin of embarkation	25
RDLF	Royal Dutch Land Forces	1
RON	remain over night	25
SARTRE	Safe Road Trains for the Environment	18
SC	Supply Centre	xi
SCM	Supply Chain Management	8
SCN	Supply Chain Network	12
SME	Subject Matter Expert	4
TEL	Transport Engineering and Logistics	1
TROPKO	Trekker-opleg-combinatie	xi
WLS	Wissel-Laad-Systeem	xi

1

Introduction

“You will not find it difficult to prove that battles, campaigns, and even wars have been won or lost primarily because of logistics.” – General Dwight D. Eisenhower

This thesis serves as a graduation project for obtaining the master of science degree in Mechanical Engineering as a specialization in Transport Engineering and Logistics (TEL). The research topic arose as a cooperation between Delft University of Technology and the DoD, Royal Dutch Land Forces (RDLF), with a focus on investigating real-time coordination between multiple agents in a supply chain and how to cope with demand and delivery uncertainties.

1.1. Context of the research and Knowledge Gap

1.1.1. Context

Behind every military mission or campaign hides a logistical plan, which is essential for the execution of these missions. With complex supply chains, having ever more valuable resources, the logistics behind a mission or campaign have become critically important. This is why the DoD acknowledges the importance of their supply chain strategy and is looking for constant improvement of their supply concept, tools, and materials for their land forces. However, at the moment the DoD and RDLF have two major issues concerning their supply chain:

1. A shortage of manpower in the Dutch army is present. The DoD tries to fill this shortage by introducing technological solutions. An interesting concept for logistics is truck platooning. This technology enables trucks to communicate and coordinate with each other, meaning a whole train (platoon) of trucks can drive with fewer drivers.
2. Due to the renewed warfare and threats, the current supply chain design is being investigated. The renewed warfare includes the developed technologies of civil and military equipment and tools, different maneuvers and different adversaries. The current supply chain is not designed for operations in the current theatre of war. Lately, logistics are a specific target during operations and therefore experience more exposure. The increase of range of enemy fires directly impacts the risks of logistics. Therefore, the DoD has new demands and criteria for a new supply chain network, that resulted in a conceptual, new supply chain model as a solution.

In 2015 a letter is written to the parliament, addressing the changes in national security. Plans were created for enforcing national security. Exploratory research was proposed having the central question of:

How to create smart and robust logistic capacities, facilitating improved maneuverability and persistence during operations in the land domain for short, medium and long term period?

New characteristics of logistic operations have been found in this research.

- A shift from Peace Support Operations (PSO) or Peace Enforcement Operations (PEO) to combat operations is inevitable. This has an impact on the way transportation of supply between units is being done. PSO knows mainly base logistics where supply is transported directly to a base location. Units resupply at the base before and after missions. Combat operations are more frontline driven supply chain, where supplies need to be transported into areas of high risk and units need to be reinforced in fighting positions.
- Networked operations are standard in the future logistics chain. A shift towards a more de-central operation mode is needed. This is mainly for spreading risks and better for supporting a more dispersed operation where multiple smaller units, often platoon level, are distributed across the battle group area of operations.
- Expected is an effective fire range of 90 kilometers from the frontline of the adversary and therefore, endangering some of the supply centers in the area. A "Notice to Move" concept is created. This concept dictates a mandatory movement at least every 3 hours. This is needed to prevent the supply centers from being spotted or taken out. Supplies preferable needs to be kept on wheels all the time, to meet the demands of "Notice to Move".

A wide varying range of possible solutions contributing to smart and robust logistics capacities have been discovered lately, most of those solutions involving higher-level automation and a more networked operation.

This report investigates the performance in robustness of several supply chain designs that meet the newly identified changes that are listed above. The research tries to gain insights for designing a robust supply chain for military operations of the RDLF. This is done by using a computer model that considers several "testing" scenarios. Also bringing to light the possible effects of truck platooning. Currently the RDLF has a generic supply chain model named "fysieke distributie" (Physic Distribution) and can be seen in figure 1.1. The current design of the supply chain is a relatively straightforward linear, multi-tiers, multi-echelon, supply chain starting from a supplier in national environments. Suppliers provide the needed supplies for the customers of RDLF, meaning the units deployed in the operational areas. The main goal of the supply chain is being able to supply the deployed units at all times, in full, at the right place.

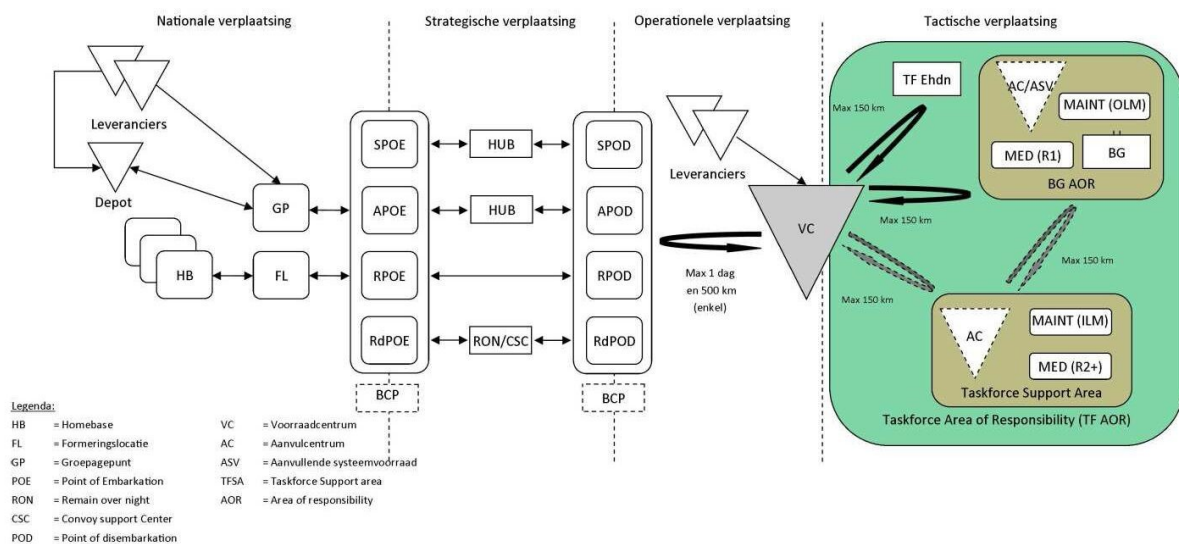

Figure 1.1: Fysieke distributie model, the current way of supplying from homebase up to combat areas.

Disruptions can have several causes like shortage of manpower or material, hostile activities or breakdown of equipment. The way of still being able to supply the land forces, even

when disruptions have occurred in the supply chain is an expression of robustness. The rate of recovering disruptions and developing a new way of supplying is called resilience, both are major focus points for the design of a new supply chain and are needed to achieve readiness of their troops. Readiness means realizing optimal procurement, supply, maintenance, and distribution time[45], in a business concept, in military context readiness mostly results in units that can perform their operation at any given time, by having enough supplies at hand at all times.

The proposed supply chain design features a highly networked way of operating, replacing the centralized supply centers by a group of smaller dispersed, but a networked group of forward supply centers. These groups are supposed to have higher mobility and a smaller risk of drop out, thus promoting robustness and resilience. How the exact supply chain should be designed and what the addition is of semi-automated truck platooning, will be discussed in this report.

1.1.2. Knowledge gab

There have been many investigations in the performances of supply chains in supply and demand uncertainties. However, few have been found to tie these performances under uncertainties to robustness. Also, this research creates a discrete event simulation that models at a detailed level that transport flows and stock levels, in a real-time fashion. Creating supply centers and routes that drop out during simulation and taking into account the demand fluctuation by the end-user. Additionally, an integer supply optimization that is coupled to the real-time stock level monitors of the units is incorporated. Furthermore, the research implements a distance based-highly dynamic flocking behavior of the supply centers to mimic the "Notice to Move" and the natural behavior of a networked operating supply chain.

Also, the military supply chain has changed a lot, however, a low amount of data on their supply chain operations is known. There is a need to close the knowledge gap of what platooning can do to secure a well-performing and effective supply chain. This report tries to develop an answer by designing a multi-agent system simulation that incorporates truck platooning and compares the effects of truck platooning on the performance of the supply chain.

1.2. Scope and Objectives

The scope of this research focuses on the last part of the generic supply chain, typically after the Point of disembarkation (POD). DoD has enough confidence that the supply chain won't be experiencing major challenges before the point of disembarkation. Since most of the logistics before POD is in own national territory, a familiar and safe environment that has good infrastructure and well-defined policies. This part of the supply chain, without a doubt, has its challenges, but due to the limited time and lower priority by the DoD, the research will negate that part.

This research will solely focus on the performance of the supply chain in terms of robustness. The focus will be on the transportation and distribution issues of supply from origin to destination, meanwhile trying to optimize this process. Locations theory, transportation theory, and allocation theory are a matter of importance. Peripheral matter, like communication delays, detailed technological restrictions are left out of the research.

Besides the supply chain, many other elements are involved in the operational area in a military context, that share possible routes, demand certain protocols or influence the supply chain in one way or another. This research focuses on the most likely occurring operations that need to be supported by a supply chain, no special operations are considered. For this research the deployed units that are supported by a supply chain, are three battalions of light infantry that are performing an operation for at most one week time.

Vehicle platooning is a good candidate as a solution for the first problem, the shortage of manpower, as is described in section 1.1. The introduction of truck platooning technology will reduce the overall amount of risk, that drivers are exposed to, during operations in the field under hostile situations. Truck platooning might be killing two birds with one stone, by reducing the number of needed drivers and ensuring higher safety. However, it is yet

unknown how the renewed supply chain performs when platooning is used in the supply chain. Therefore the objectives of this research are:

1. Find out what defines a robust supply chain for military operations.
2. Develop a discrete event model to simulate supply chains and scenarios.
3. See to what end truck platooning affects the robustness.
4. Explore further improvements for the supply chain, also looking outside the military context.

By completing the objectives, the research questions will be answered accordingly. A summary of the research questions and approach are given in the section below.

1.3. Research Question

To guide the research to a final goal, one main research question is defined, which will fill the knowledge gap. To answer the main research question, several sub-questions need to be defined as well. The research question forms the backbone of the report and is a guideline in creating stepping stones that lead to closing the knowledge gap. The main research question is formulated below:

How to design a robust supply chain for military operation considering platooning?

Sub Questions

To answer the main research question several sub-questions immediately arise. The sub-questions are the stepping stone in closing the knowledge gap and thus finally answering the main research question. The sub-questions are listed below:

1. *What are the criteria for a robust supply chain in military environments and how to compare those criteria?*
2. *How is the supply chain of the Royal Dutch Land Forces designed?*
3. *What effect does truck platooning have in a military supply chain context?*
4. *How to design a supply chain for military operations?*
5. *How can we generalize the findings for networked supply chain problems outside military environments?*

1.4. Approach

This section discusses the approach in solving the research questions. An approach is a method to find out the needed information. The various methods to answer the sub-questions are as follows:

- Literature research
- DoD documentation
- Business documentation
- Interviews Subject Matter Expert (SME)
- Modeling

Through a literature survey more knowledge is acquired about current simulation techniques, comprehension of supply chain and truck platooning. By creating a supply chain model and developing a simulation, performance comparisons can be executed, resulting in numerical experiments, with several "scenarios". The main goal is, to be able to answer how a robust supply chain can be designed, using platooning. However, before this question can be solved several sub-questions need to be answered first.

Below each sub-question is listed in bold. directly beneath are in italic that various methods needed to come to an answer and below a short description that justifies why these methods are suited for the sub-question.

What are the criteria for a robust supply chain in military environments and how to compare those criteria?

Literature research, Interview SMEs, DoD documentation, Business documentation

This question tries to reveal the fundamental properties of robustness and can be found by interviewing SMEs, looking into scientific papers and checking the DoD Documentations. Probably some different properties to robustness will be acknowledged by all three information sources, but the overall consensus and overlapping opinion will define robustness for military supply chains. In the end, definitions should be known, some key performance indicator (KPI)s for the model should be clear and different design scenarios are covered. This question will need some information on robustness translated into KPIs that can be observed and thus measured. These KPIs inform us about the performance of the supply chain. Then suited scenarios that occur during operations need to be described, as this enables us to see the effect these scenarios have upon the KPIs. Also, To-Be versus As-Is supply chains can be compared.

How is the supply chain of the Royal Dutch Land Forces designed?

Interview SMEs, DoD documentation

This is a relatively small sub-question, however, it is important to cover this and see of what elements the supply chain of the RDLF is created. It also captures important processes and protocols that are involved that can affect the robustness and performance of the supply chain. This is mainly explored by consulting SMEs and checking DoD documentation.

What effects does truck platooning have in a military supply chain context?

Literature research, Interview SMEs, Business documentation

That truck platooning can deliver a solution to the shortage of manpower is relatively clear. However, what does it mean in terms of robustness when truck platooning is involved. Some literature research in scientific documentation is needed to explore the boundary conditions of truck platooning, SMEs, will give insights into the demands of truck platoons, when driving convoys. Business documentation will also reveal some usages of truck platooning. In the end, some characteristics of truck platooning regarding robustness need to be extracted, to make a statement about considering the technology in the supply chain.

How to design a supply chain for military operations?

Literature research, Interview SMEs, modeling

The modeling will result in certain designs of the supply chain that incorporates the properties and constraints of truck platooning and networked supply centers. For this question, it is important to check the DoD documentation of the demands for highly mobile supply nodes. These highly mobile nodes incorporate the platooning properties already presented by answering sub-question 3 but need additional information about in what capacity the nodes need to operate. DoD documentation and SMEs will give the information needed to be able to model this into the network.

How can we generalize the findings for networked supply chain problems outside military environments?

Business documentation, Concluding of research

The findings of the design of the supply chain after numerical experiments will give some valuable information that could also apply to non-military scenarios. How could this model serve for non-military environments and what needs to be adjusted to make it fit the non-military environments? To what ends can the findings in military applications aid the non-military sector?

1.5. Further Lay-out of the Report

The next chapters of the report will be as followed, in chapter 2 a literature survey will be presented about the newest developments and state of the art knowledge concerning: supply

chain management, simulation techniques, platooning and multi-agent systems. Chapter 3 will present a theoretical background about military supply chains, most of the information is gathered by documentation within the Dutch department or foreign departments of defenses, the chapter aims to create a good understanding of the supply chain that we are dealing with in this thesis, as it is essential for a decent further analysis. Chapter 4 focuses on the possibilities of truck platooning and the effect on the supply chain in terms of robustness. This is done by combining the knowledge of scientific research about truck platooning with the criteria and boundary conditions needed for truck platooning operations in a military environment. After chapters 1, 2, 3 and 4, sufficient information about how to create a valid model with the right detail level should be available, also the knowledge about performing numerical experiments for the design of a military supply chain is present. Chapter 5 discusses the approach of the system analysis and simulation that is most suited to implement in order to solve the main question, and will further elaborate on the transformation of a paper model to a computer model and what approach is chosen. Chapter 6 discusses the simulation model and will further explain the important elements involved. Chapter 7 will discuss the numerical experiments performed and presents results of the experiments, chapter 7 starts with a sensitivity analysis, model robustness testing under certain load cases and a case study matched in an environment that closely relates to a real-life scenario. Chapter 8 discusses the results and tries to capture relations concerning robustness and certain designs of the model. Chapter 9 concludes the experimental aspect of the thesis and answers the main research question. Chapter 10 concludes the whole thesis with a recommendation and reflection of the graduation project.

2

Literature study

2.1. Introduction

This chapter will present the state of the art knowledge, findings and experiments that are closely related to this graduation assignment about designing a robust supply chain for military operations, considering truck platooning. As stated in the introduction chapter before, the literature study is performed utilizing a literature survey in scientific papers, that can be found online at the most widely accepted search databases for scientific papers. The databases that have been consulted are *Google Scholar* [1], *Scopus*[3] and *Research Gate*[2].

Besides these online sources, a large body of internal documentation is available for study at the DoD. The documentation found contains specific information about the supply chain of the RDLF and all associated information. The topics of the internal documentation will address all military aspects for *operational* logistics including; supply chain models, specifications, configurations and techniques used. Please note that the word operational is stressed here. This is because this research focuses on operational logistics, meaning in-field practices. Furtherers will be clarified in the upcoming chapters.

The combination of in-house knowledge that is specified for the Royal Dutch Land Forces, with the latest developments in scientific and business sectors, gives new insights for the supply chain usage within the armed forces.

In this chapter we seek to answer the first sub-question and parts of the third and fourth sub-question:

What are the criteria for a robust supply chain in military environments and how to compare those criteria?

What effects does truck platooning have in a supply chain context?

How to design a supply chain for military operations?

Parts of the findings of the scientific literature will be combined with findings in DoD documentation. Expected is that definitions about robustness will differ, but the information can mutually confirm the findings within a certain spectrum, so findings can be generalized and still decent conclusions can be drawn about what robustness means and how one can compare robustness. While exploring different simulation methods and supply chain design, some initial findings will be revealed. These findings are taken to the next chapter to be able to answer the sub-question satisfactorily.

2.2. Main Topics

Besides just trying to answer the sub-questions stated in the introduction, further exploration of relevant topics are being done. As a guideline to topics that are of interest, the

nouns in the main research question are listed below and give a focus. Topics that are important for this research are *Supply Chain (Management)*, *Truck Platooning*, *Simulation* and *Multi-Agent Systems (MAS)* and *Discrete Event Simulation (DES)*. Below a short description is given per item, explaining why these are important.

- "Supply Chain Management (SCM)": Further referred as SCM, gives valuable insights in how to design a SC in order to operate it effectively. The term "supply chain" originates from the military sector, but is meanwhile developed a lot more due to the commercial sector. What makes a good supply chain and how to measure the performance and robustness? For military purposes it is important to have a high level of order fulfillment, this demands a robust supply chain. What creates a robust supply chain and how is this to relate to the discussion about supply chains nowadays in scientific literature or business documentation?
- "Truck Platooning": The Department of Defense sees possibilities in the usage of truck platooning to fill the gap of manpower shortage. What are the latest developments in platooning, what are the boundary conditions and characteristics for military usage and especially what has platooning to offer when looking at the supply chain of the RDLF?
- "Simulation Possibilities": To perceive the effects of the supply chain and platooning there is a need to develop a simulation for testing and exploring the supply chain under several scenarios that might be interesting for investigation of robustness. However what simulation techniques are available and are most suited for this research?
- "Multi-Agent Systems": further referred to as "MAS", when looking a bit further than just truck platooning, the next step is a fully autonomous supply chain. Consisting of many mobile vehicles. The possibilities and most recent discoveries concerning MAS are discussed. also how to model a MAS is one the interests to reveal.

2.2.1. Supply Chains

Supply chains have to deal with a large number of logistic operations, that can become quite complex. The military may have been the first institution to recognize the importance of supply chains. Romans built roads across greater Europe to move and equip their legions and proceeded to conquer the known world. Books are written about the successes of Alexander the Great due to his careful logistic planning. Napoleon booked great successes as well by well-developed supply chain plans of his generals. The first systematic effort to define the word with some precision and to relate it to other elements of war was made by definition logistics originates from the late 19th century from French word "Logistique" (logis = lodging) which first appeared in the book "Summary of the Art of War" and was described as "the practical art of moving armies" by Antoine Henri Jomini [40] who was the general in French army during Napoleon's rulership.

There are however many varying definitions that try to describe logistics, according to the Oxford English Dictionary logistics means: "logistics (of something) the practical organization that is needed to make a complicated plan successful when a lot of people and equipment are involved". When consulting the Cambridge Dictionary logistics is: "the process of planning and organizing to make sure that resources are in the places where they are needed, so that an activity or process happens effectively".

The same is to be said about definitions trying to describe the relationship between logistics and SCM. According to the author, the best way to capture the SCM to logistics relationship is described by Wallace A. Burns, Jr., Ed.D. Consulting Manager, Associate Professor in the School of Business, Transportation and Logistics Management Program, American Public University:

"Think of the supply chain and logistics as simply this: Logistics is comprised of storage and distribution, which is a subset of the supply chain, which deals with additional customer-tailored components such as schedules, procurement, inventory control, product life cycle management, pricing, demand management, forecasts, and partnerships with strategic and tactical enablers."

The purpose of a supply chain is to add value to its products as they pass through the supply chain (the input part) and to transport them into geographically dispersed markets

in the correct quantities, at the correct time, and at a competitive cost.

The origin of SCM can be traced back to the 1950s, when Forrester studied the dynamics of industrial production-distribution systems[31]. The purpose of a supply chain is to add value to its products as they pass through the supply chain and to transport them into geographically dispersed markets in the correct quantities, at the correct time, and for a competitive cost [20].

At the operational level, the supply chain management network manages three types of flows that require careful planning and close coordination:

- Material flows: represent physical product flows from suppliers to customers as well as the reverse flows for product returns, servicing and recycling.
- Information flows: represent order transmission and order tracking and coordinates the physical flows.
- Financial flows: represent credit terms, payment schedules, consignments, and title ownership arrangements.

The network itself is supported by three pillars [5]:

- Processes: embed the firm capabilities in logistics, new product development, and knowledge management.
- Organizational structures: encompass a range of relationships from total vertical integration to networked companies as well as management approaches and performance measurement and reward schemes.
- Enabling technologies: include both process and information technologies.

For this research it is interesting to see what types of flow are relevant and how these are managed, or perhaps should be managed. When talking about the pillars, most of the interests in this research will possibly be deviated to processes and enabling technologies of the pillars.

When trying to investigate on how to operate a supply chain to realize a well-functioning supply chain and constant flow of supply, mainly to types of operating are described. These two type are a *lean* or *agile* supply chain.

According to Christopher, lean and agile are distinctly different, since in the first case the market winner is cost, whereas in the second case the market winner is availability. Agile supply chains are required to be market sensitive and hence nimble [17].

Lou et al defines agility as the ability to quickly respond to markets changes, called agility, has been recognized as a key element in the success and survival of enterprises in today's market[47].

Agility is needed in less predictable environments where demand is volatile and the requirement for variety is high, whereas leanness works best in high volume, low variety and predictable environments [16]. A representation can be found in figure 2.1

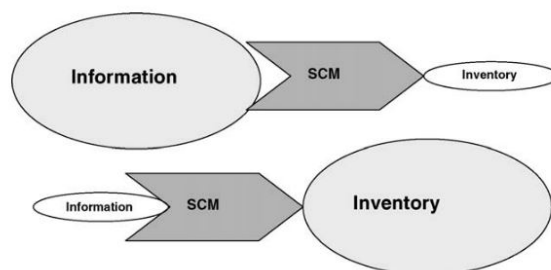

Figure 2.1: Representation of information availability versus availability of inventory [25].

Supply chains can be agile and lean combined, if that is the case there is a certain point, mentioned as the decoupling point, where lean transforms to agile or vice versa. Ideally, this

point, localized into any platform, plant, distribution center, warehouse, depot, or another logistical platform, should lie as far as possible, downstream in the SC, and so near to the final customer coping with order fulfillment in real-time and propose the postponement or delayed differentiation [9][14]. In the figure below an illustration is shown of such a decoupling point and its characteristics 2.2.

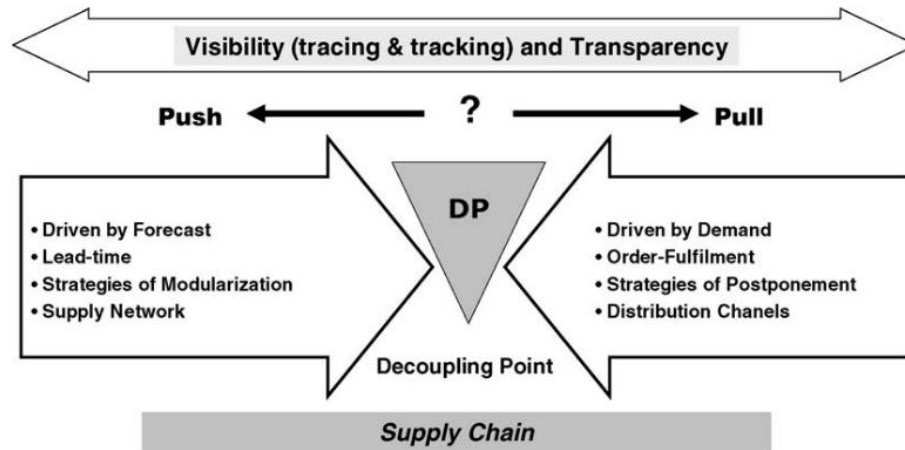

Figure 2.2: Illustration of a decoupling point and some characteristics [17].

According to Ren Lin et al. agility can be "measured" by the following dimensions[32]:

- efficiency: defined as the cycle time reduction of business processes.
- flexibility: defined as the minimization of costs involved in dealing with changes in the process.
- robustness: defined as the strength of the information system to handle uncertainty in the process.
- adaptability: defined as the self-learning ability of the information system such that the performance of the business process can be improved incrementally.

So when working in an agile supply chain, it is important to check the four mentioned dimensions. For military environments, efficiency is important, but not key. When taking the 3 other dimensions to a broader level, robustness not only concerns uncertainty in information, but also uncertainty during operations. Adaptability could be seen as the ability of the supply chain to adjust or improve itself to changes. When working agile in military environments, robustness and adaptability are key, explaining why this research focuses on the robustness of a supply chain.

That military and commercial logistics are recently more intertwined have not gone unnoticed. Military logistics and commercial logistics are part of the same industry. Both are concerned with focused logistics, precision and velocity, coordinated delivery schedules, fast and flexible distribution, and good infrastructure and equipment at distribution centers. Reliability- a guaranteed level of service- is still key for customers in the logistics industry [45].

Rather than earning profits, one of their primary objectives is achieving and maintaining a high state of readiness. The study investigates how to define characteristics of the military, as a non-market, closed-loop, supply chain focused on readiness, affect resource allocation decisions and the consequent design of the supply chain [81].

The over-riding goal of the military's supply chain is to keep the war-fighter properly equipped and ready for combat; and this trumps other considerations such as costs, efficiency, and budgets. Thus, the military seeks efficiency in its operations even as it rebuilds its personnel and equipment and trains for the next engagement. Readiness is the objective, cost the constraint [81]. Some relevant supply chain improvement techniques proposed by Wilhite for the military are:

- Standardization of commercial and military logistics metrics and equipment.
- Real-time stock information.
- Minimal customer wait time.
- Inventory reduction: Stocks in warehouses will be kept at a minimum, continuous resource reduction, supplies "kept on wheels".

M. McGinnis compares military logistics with business logistics and has some interesting findings that are still relevant today. From literature, he noted that the military logistics do recognize that logistics at all levels is highly dependent upon timely information regarding resources and requirements [52][28]. For those who research logistics, the implications of these results suggest that future challenges will emphasize the study of dynamic complex processes rather than stable system components. This suggests that concepts will be more difficult to develop, data will be more difficult to quantify, and that findings and conclusions will be relevant for shorter periods. Besides, research into Reliability-Availability-Maintainability Logistics, Project Logistics, and Material Flow Systems may also provide insights useful to business logistics[52]. Finally, military logistics literature emphasizes that logistics processes occur in environments that are often dynamic and unpredictable. As a result the management of logistics processes often requires a combination of forecasting ability, the ability to control that which is controllable, and the flexibility to adapt to changing conditions and unexpected events [52].

Military logistics planning (LPS) is a complex and time-consuming process. LPS is a project aimed at developing support for the logistics planning process by automating logistics plan formation, analysis, and information gathering. LPS uses agents to model the business process, expertise and interactions of the various organizational and information entities. Together, the agents will automate the logistics planning process, allowing the logistics planners to focus their effort on refining the logistics plan, rather than forming a logistics plan [71].

Tortonesi stresses the importance of automated supply chain logistics. "Accurate and fine-grained information gathered could significantly benefit military intelligence, surveillance, and reconnaissance operations, facilitate automated supply chain logistics, and facilitate urban operations in mega-city environments" [72].

It is interesting to see what agents could achieve in the supply chain of the Royal Dutch Land Forces. The development of an LPS is a decent idea to see how the layout of the Dutch military should supply chain should be and gives us room to refine this supply chain.

The basic forms of operating a supply chain have been a bit more elaborated. Definitions have been given, different types of operating and some techniques for improvement are also shown. Some more in-detail information about former research of robustness is still missing and more information about agent-based supply chain models needs to be collected.

Robustness

Robustness is a demand for the supply chain of the DoD and as can be read in the literature study above an aspect of an agile supply chain, but what defines robustness and how to measure it? Robustness has been studied in many scientific reports presented below.

A significant body of literature tries to describe various matters of achieving robustness. Tang et al. for example presents some robust supply chain strategies for mitigation of disruptions in supply chains. Acknowledged is that issues mainly occur in supply management or demand management. However, in the end, a list of 9 strategies are presented to increase robustness during business supply chain disruptions, as listed below [70]:

- Postponement
- Strategic Stock
- Flexible supply base
- Make-and-buy
- Economic supply incentives
- Flexible transportation
- Assortment planning

- Revenue management via dynamic pricing and promotion
- Silent product rollover

As can be noticed, the methods vary from policies to processes and applying techniques in operations. At last, the paper concludes and suggests further research to reduce the impact of disruptions and thus the risk of a failing supply chain:

- Supply alliance network
- Lead time reduction
- Recovery planning system

Two ways of creating a robust supply chain are particularly of interest in this research. Flexible transportation and strategic stock are closely related to this military research project. As for the conclusion of reducing lead times, this is one of the keys to reduce the likeliness of dropouts in the supply chain on the RDLF.

Klibi et al. discusses a Supply Chain Network (SCN) design problem under uncertainty, and presents a critical review of the optimization models proposed in literature [41]. Klibi concludes that robustness has much to do with responsiveness and resilience of a SCN, where responsiveness is the adequate response in short term variations in supply, capacity and demand and resilience can be seen as the capacity of a system to survive, adapt, and grow in the face of unforeseen changes, even catastrophic incidents[24]. According to consultants of Holland & Davis Lcc resilient can be defined as [38]:

- Elastic and adaptive enough to stay on track
- Capable of retaining or resuming its position
- Capable of recovering rapidly from adverse conditions
- Capable of taking advantage of opportunities when everyone else is dodging bullets

In the end, some further research recommendations are given, one of them, relevant for this research is their recommendation for SCN design modeling that is based on representative samples of plausible future scenarios, using stochastic programming and/or robust optimization approaches[41].

The complexity of supply chain design under uncertainty is explored in Lieckens and Vandaele, where they address the lead times and uncertainty in the collection, production, and transportation as well as uncertain supply, uncertain process times, and unknown quality breakdowns[46].

Melnik et al. argues that effective supply chain design should be based on one or more of six strategic outcomes: cost, responsiveness, security, sustainability, resilience, and innovation[53].

A networked supply chain is also introduced by the renewed supply chain model of the DoD. The older version has just a linear SC, so probably some interesting changes will occur in the new model concerning robustness. Again an overview of papers is shown below.

An important property of networks is whether or not they are subdivided, i.e. whether they consist of sparsely interconnected 'clumps' of highly interconnected nodes. When a network is subdivided, node state changes can occur within a given clump with only minor effects on the other clumps. This has the effect of allowing the network to explore more states more rapidly. Rather than having to wait for an entire large network to converge, we can rely instead on the much quicker convergence of a number of smaller networks, each one exploring possibilities that can be placed in different combinations with the possibilities explored by the other sub-networks[78].

Agent-Based Supply Chain

A relatively new concept for supply chain management is the use of an agent-based approach. Agent-based supply chains are used more often to control the supply chain from beginning to end, so supply chain management does not strive for internal efficiency of operations, as logistics aimed for in the past), but instead for the management and coordination of the activities throughout the whole supply chain[11]. Several studies show the effectiveness of the agents in controlling, procurement, stock and order fulfillment.

According to Lee et al., The most relevant area of real-world application for MAS modeling concerns the study of network dynamics. MAS are especially capable of capturing those aspects of network behavior which change over time. The rationality of business decisions concerning order allocation, demand forecasting, pricing and workforce, and plant investment—all functions with a time dimension – thus centrally fall within the scope of MAS modelling [44]. The preceding review suggests that the next step in modeling must be to account for the complex network arrangement of manufacturing systems or SCs, where agents sharing a different tier may compete for immediate agents. This competition results in several system variabilities or fluctuations in parameters like cost, reliability or volume of supply that a more purely conceptual or deterministic model would not necessarily generate [44].

Fu-Ren Lin et al. proposes a multi-agent information system (MAIS), approach to model the order fulfillment process of a supply chain. Several improvement strategies are applied using SWARM to simulate the results. The most interesting strategy giving a result that might be applicable in this papers' simulation is the dynamics material allocation strategy. Two effects are noticed:

- The dynamic material allocation strategy is an effective approach to reduce OFP vulnerability due to supply uncertainties and to improve OFP robustness under demand uncertainties.
- The effectiveness of dynamic material allocation strategy is highly influenced by the information transfer efficiency [32].

Carvalho et al. successfully show that multi-agents systems technology can be used to model, study and manage supply chains, also they have presented some new tools and results [13]. The use of intelligent multi-agent technology will provide a lean supply chain, more flexible and efficient from the push side and more agile and effective from the pull side, being demand-driven according to Dias et al. [25]. Lout et al. say that a MAS, which is characterized by flexibility and adaptability, is suitable for an open and dynamic environment. Thus MAS is a good method for agile supply chain management[47].

Figure 2.3 illustrates the interaction between the control strategies and the general simulator. The control strategy manages production and distribution and the simulator controls consumption and simulates production, distribution and consumption[78].

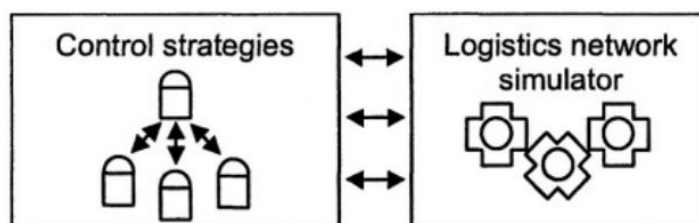

Figure 2.3: Representation of the control strategies and general simulator interaction.

Multi-agent modeling techniques are applied to simulate and control a simple demand-driven supply chain network system, with the manufacturing component being optimized through mathematical programming in Gjerdum et al. [33]. Here some variables related to re-order moments are varied while aiming for reduced inventory costs and high customer fulfillment.

A multi-agent approach is also used for transportation problems with disturbances during transport itself, the possible disturbances are programmed as agents [37]. Also in the context of military applications, where a lot of disturbances will take place, this approach is useful.

The papers above present a successful implementation of MAS to avoid for example the bullwhip effect, as the well known MIT Beer Game shows, the inter-dependencies between the single tiers affect the overall outcome of the logistics chain from the final retailer to the manufacturer[68].

Ettl et al. [30] developed a model for maintaining a certain stock level in all stores in the supply chain. While trying to realize this taken into account are bill of materials, lead times, demand and cost data and customer service level.

2.2.2. Modeling and Simulation

Several arguments were found in literature about why a simulation is a good option when looking into supply chains. First, Supply chains are complex operations and their analysis requires a carefully defined approach. It is easy to get lost into details and spend a large amount of effort in analyzing the supply chain. On the other hand, it is also possible to execute too simplistic an analysis and miss critical issues. Simulation has been identified as one of the best means to analyze supply chain models [65]. Second, due to agents' natural modeling capability, simulation is one of the favorite deployment scenarios of multi-agent technologies. Engineers tend to use agents as an alternative to classical simulation and modeling techniques due to their enormous expressively and run-time reconfiguration possibilities. Identical (or very similar) software environment can be used for simulating but also for the real installation[58].

Supply chain analysis: Spreadsheet or simulation written by Chwif et al, shows the importance of dynamical-simulation compared to a static-spreadsheet analysis. Concluded was that when incorporating varying demands, spreadsheets can give faulty results. This is of course in line with intuition, due to a more probabilistic need for approach. In a case study of Brazilian aluminum production, a discrete event model was created were not only demand, but also travel times vary according to a normal distribution, one of the conclusions is that for demand variation simulation is much more favorable than a static analysis [18].

According to Dias, the latest developments in the modeling technology, agent-based systems, and multi-agent systems, are quite promising modeling situations. They are best suited to handle issues of information asymmetry, decentralized and distributed decision-making, and modeling inter-enterprise issues. Autonomous agents and multi-agent systems represent a new way of analyzing, designing, and implementing complex software systems. They are expected to pioneer a revolutionary paradigm shift in software systems modeling and engineering [25].

In particular, the multi-agent system approach could bring to the SCM tasks important advantages, such as reliability, based on dynamic redundant agent organizations; modularity and scalability, since new capabilities can be added and deleted without breaking or interrupting system operation; adaptivity, agents have the ability to reconfigure themselves to accommodate new changes and events; Concurrency, agents are capable of reasoning and performing tasks in parallel, which in turn provides more flexibility and speeds up computation; and finally, Dynamics, agents can dynamically collaborate to share their resources and solve problems [82].

Modeling and simulation are extremely suited for supply chains. There are however many modeling and simulation techniques. The supply chain can be modeled in different ways. One can see to it as a flow of materials. When talking about flows and modeling, a system dynamics approach is the way to go. It models the whole supply chains and gives deterministic meanings to it, considering a steady-state flow. According to Greasley, system dynamics method maps a problem onto a generic structure that can help to understand the underlying causes behind the behavior of the system [34].

When seeing the model as objects that handle several processes, states and believes, then Object-Based Modeling (OBM) is the best way to tackle the design problem of designing a robust supply chain. Zee and Vorst discusses a modeling framework for supply chain simulations, using object-oriented coding and assembled an overview of main characteristics for a framework [84]:

- Modeling elements and relationships; consisting out of agents, jobs (or processes) and flows. Agents are entities that have a certain level of intelligence and level of discussion possibilities. The activities, often within an agent, are called jobs or processes. Flows are often move-able objects without any intelligence, sometimes called resources.
- Model Dynamics describes how the agents are connected in networks and how jobs are or should be executed.
- User Interface is a recognizable building block for improvement of understanding, and visibility of the supply chain.

- Ease of modeling scenarios: object-orientation facilitates a natural one-to-one mapping of real-world concepts to modeling constructs.

A supply chain can be observed as a series of queues that enable a certain supply to flow from one point to another. While the supply is flowing through it experiences several events along the way, those events determine the way the products flow along. In that case a Discrete Event Model (DEM) is best. DEM are often accompanied by a simulation, often quite useful for verification of the model, but also a great selling point for convincing the usefulness of the model itself. DES is used in queuing simulations and complex networks of queues. DES is a good option when we deal with well-known processes, for which the situations of uncertainty are defined using statistical distributions [37]. Greasley points out that discrete-event simulation technique attempts to replicate the structure of the system and then allows performance to be measured under several scenarios [34].

Another approach is to create agents, that have a certain intelligence for deciding what choices need to be made. For this approach an Agent-Based Modeling (ABM) having multiple agents is best suited. An example of an agent-based modeling process is given by Macal et al. Here the process is described for agent developing process and a collection of questions needed to be answered before developing the correct agent based model [48]. Also, it could be a symbiosis of several programming styles, combining the strength of multiple modeling styles, however, this can become complicated very fast. When wondering if multiple simulation techniques can be combined, like say discrete element modeling and system dynamics or agent-based modeling, DES and SD have been combined sometimes, but no real integrated model has been made so far, the same is told about ABS [49]. There are some elementary differences between DES and Agent-Based Simulation (ABS) like DES is passive, while ABS is active, also DES focuses on networks of queues, this isn't the case with ABS.

An example of a combined modeling process is presented by Djanatliev, where decision making in the field of health technology assessment is not a simple task and is important for different stakeholders, particularly for health industry companies. In the paper, a multi-paradigm simulation method has been presented using SD for simulations at a high abstraction level and ABS/DES at an individual level in a common simulation environment [26].

When considering a simulation it is important to compare the new operating vision versus the older one, meaning there are 2 models needed for simulation. The "as-is" versus "to-be" and a comparison between those can give some essential information, based on several KPIs. Proposed KPIs are:

- service levels
- inventory turns
- order to delivery times

A good methodology is as follows according to Jain et al.[39]:

- Development of an As-Is process model
- Development of the As-Is simulation model
- Development of a To-Be process model
- Development of the To-Be simulation model
- Comparative analysis of As-Is and To-Be scenarios

When developing the process model, for statics process mapping of the overall supply chain, it is essential for collecting the relevant processes in the chain by asking SMEs and documentation. It leads to more accurate abstraction for the simulation, reducing complexity while maintaining effectiveness. When simulations are performed, a sensitivity analysis is also good to make sure all processes included are relevant (or missing out). The process models for As-Is and To-Be will be captured in Visio.

Result validation needs to be done by literature information collection, company documentations, and estimations and interview subject matter experts.

The modeling framework is meant as an explicit guide for the analyst in building higher quality simulation models concerning transparency and completeness, thereby allowing for

improved decision support[84]. For modeling framework, the Delft systems approach is used and will be further evaluated in the next chapter.

Several packages for agent-based modeling and simulations are being collected and analyzed by Abar et al [4]. Since the author has an affinity with mainly python and Matlab, all java options are discarded. Several python packages are presented, that are interesting for this research. MESA is one of the suited Python for moderate development effort and light-weight/medium scalability SIMEvent Matlab moderate development strength and medium to large scalability UrbanSim python language with moderate development strength and suited for large scale implementation, mainly focused for urban development planning and modeling. Two discrete event packages that are open source and available for use are SimPy and Salabim. Both are using python as a language and have extended features for designing a discrete even model. Salabim favors SimPy due to its extensive simulation and monitor functions available. In general, both of them have the same approach when modeling a discrete event model, both have an OBM programming style, ideal for MAS programming, however, got distinct specialized functions for structuring the DEM.

To investigate if platooning is indeed an option for performing in a networked supply chain, a simulation is needed. Unfortunately, no actual data is known. Also, the newer networked way of supplying is not developed yet. This is where simulating can solve the question of whether or not the networked model can work with platooning, and also check if it is an actual improvement or not.

Two modeling options are most likely to be used: Discrete event modeling and Agent-Based modeling. Each having its weaknesses and fortes.

Multi-agent systems and Discrete event modeling have been compared by Becker et al. Several typical differences have been observed, that might have an impact on the preferred simulation technique that can be chosen in this research [7]. The MAS programming paradigm fits nicely the idea of autonomous entities representing logistic objects. At the same time, it allows for an easy adaptation of agents tested in simulations for real-world applications. The DES, on the other hand, is very specifically designed to the problem of simulating autonomous logistic processes. The presented discrete event simulation system is more specific and thereby it is particularly well suited for the analysis of transportation and communication activities in autonomous logistic processes [7]. At last DES knows a faster run time behavior and is nearly 400 times faster as agent-based simulation. When given the correct set of values, DES seems to have a much better reproducibility.

Dubiel et al. proposes to integrate agent-based modeling with discrete event simulation to simulate the movement of people in a discrete event system. They are aware of the benefits of DES, but the lack of programming ease when trying to simulate moving agents, like people. ABS is the more suited way of simulating moving agents. In the paper, they argue that ABS can be integrated into a DES [27].

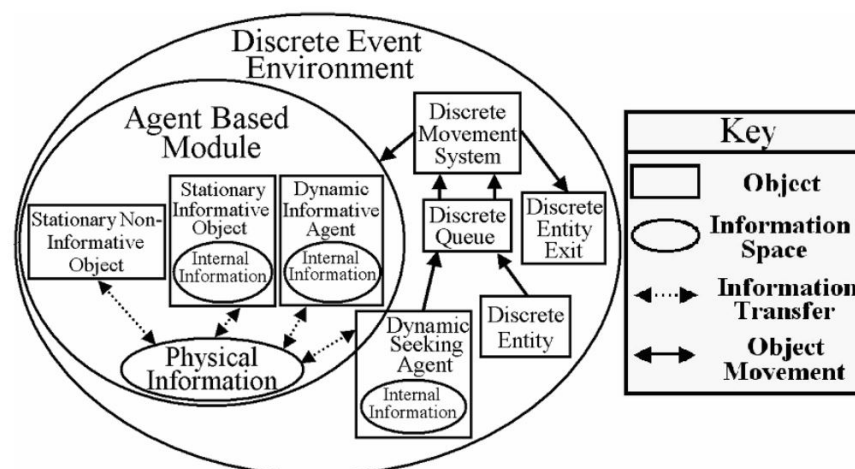

Figure 2.4: A representation of the model to be created for this research, already considered by Dubiel [27].

2.2.3. Truck Platooning

Vehicle platooning is being investigated a lot lately by scientists and companies. It is the linked driving and semi-autonomous driving of multiple vehicles closely behind each other, thus forming so-called platoons. In general, truck platooning uses a so-called leader-follower method, where only the first truck has an active driver, the following trucks adjust their speed and direction according to the shared information of the truck in front or leading, and behind using sensory equipment or information exchange via an ad-hoc or local network. The most promising principle behind this new way of driving is called cooperative adaptive cruise control (CACC).

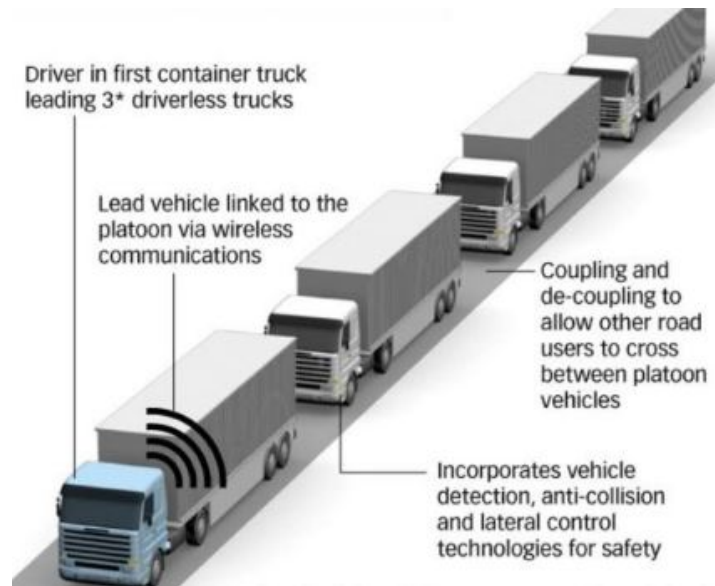

Figure 2.5: A schematic representation of an example of truck platooning [23].

There are important distinctions between CACC and automated truck platooning. First, with CACC, only truck speed control will be automated, using vehicle to vehicle (V2V) communication to supplement forward sensors. The drivers will still be responsible for actively steering the vehicle, lane-keeping, and monitoring roadway and traffic conditions. Second, while truck platooning systems have relied on a Constant Distance Gap (CDG) control strategy, CACC has relied on a Constant-Time Gap (CTG) control strategy, where the distance between vehicles is proportional to the speed [54].

CACC technology allows connected and automated vehicles to form vehicle platoons with shorter inter-vehicle distances. Since vehicles are tightly coupled with their neighbors, the roadway capacity is highly increased, while the energy consumption is reduced due to the mitigation of aerodynamic drags and unnecessary speed changes. Numerous research work has been conducted so far to apply CACC technology to vehicle platooning [79].

A simulation study was conducted and the potential impacts that truck platooning would have on vehicular mobility and the environmental impacts of driving are analyzed. The expected benefits of implementing the system described here are delay reductions by up to 91% and up to 75% reduction in fuel use, among other measures [50]. Tsugawa et al. describes a possible fuel saving per truck that is dependent on gap distances as it is tested within the project of "Energy ITS" (<http://itsasia-pacific.com>). Possible savings per truck are around 20% per vehicle in practice. Theoretical up to 38% per vehicle is possible [74].

Bergenheim et al. presents an overview of 5 different vehicle platooning projects, the expected outcomes of the projects are an increase in fuel and traffic efficiency, an increase of safety and comfort [8]. One particularly project of interest is the SCANIA-platooning focused on heavy-duty vehicles. The Dutch land forces have recently acquired new SCANIA trucks, the collaboration between the land forces and SCANIA will benefit the implementation of vehicle platooning of their trucks.

Still, a lot of challenges need to be overcome especially with regards to communications [59][85], stability, heterogeneous platooning which is the platooning of different trucks and cars among each other [36] and for typical issues like leader election multiple proposals are made [67].

According to Safe Road Trains for the Environment (SARTRE) European research for platooning there are multiple benefits, besides just fuel consumption. SARTRE estimated a 20% fuel reduction, safety improvement expressed in 18% prevented fatal casualties, increased flow of traffic and much faster resolving of congestion and traffic jams [64].

There are however hazards, the most prominent hazards are related to the risk of a vehicle in the platoon running into the preceding vehicle, and another commonly mentioned risk is that caused by cut-ins from surrounding traffic. Many potential technical failures can cause these hazards, such as failures in communication, computation, sensors, actuators, position, and infrastructure. Also, there is a large set of human factors that can cause hazards, including risks related to the introduction of automation, driver workload, and situational awareness [6].

Halle et al. address collaborative driving by using a platoon of cars considered as more or less autonomous software agents and aims to incorporate the vision of a multi-agent system to the platoon architecture and coordinate vehicles through teamwork for agents model [35].

Recently, there has been a notable uptake of allowing ad-hoc car-to-car communication (C2CC) supported by major automotive companies such as DaimlerChrysler or Volkswagen [58].

On the other hand, the community is busy developing demonstrators and prototypes that exploit better the potentials of multi-agent technology in truly distributed environments—such as integration of supply chains, air-traffic-control or car-to-car communication. Unfortunately, we are not aware of any such mature applications to be reported until now [58].

2.2.4. Multi-Agent Systems

Due to the nature of the supply chain in this volatile environment and from literature study, modeling with agents is probably the best way to go. Before starting modeling with agents, some further research is done in the multi-agent models, that present the needed dynamics, laws, consensus and formation control algorithms, that are needed in aiding a correct implementation of the agents. MAS is investigated a lot lately and it contains a broad spectrum of subjects on its own.

Pechoucek et al present a paper where multi-agent technologies and industrial applications of multi-agent simulation with a special focus on manufacturing, logistics and defense applications [58].

Cao, Yu, Ren, et al. have tried to review the main result and progress in distributed multi-agent coordination, including papers from up to 2006. Generally, 2 approaches are chosen for MAS controlling, a centralized and a distributed approach. Assumed is that distributed control is more promising due to physical constraints and multiple advantages, like high robustness and scalability [?]. One of the discussed results, that is useful for this research is the formation control, sometimes called flocking, of MAS. A decentralized configuration of the multi-agents in the papers' model is preferred as well. Due to the nature of the supply chain replenishment.

In the supply chain changes of the DoD a description is given of a dispersed, highly mobile appearance. This resembles the flocking behavior of swarms of birds. All assets in the operational area are moving independently, however, are interconnected. It is interesting to implement this behavior in the supply chain, this asks for a need for a control algorithm. When considering flocking, there are 2 types of formation control. One is *formation producing*, the second is *formation tracking*. The main difference is the absence of a group reference when talking about *formation producing*. Formation tracking is generally harder to accomplish due to additional information need about the group references concerning location, speed, acceleration.

According to Cao et al. is formation control more desirable in many practical applications such as formation flying, cooperative transportation, sensor networks, as well as combat intelligence, surveillance, and reconnaissance [10]. That is why in this research, formation

control will be explained a bit more about, especially about the latest results. The main objective of formation control is to coordinate a group of agents such that they can achieve some desired formation so that some tasks can be finished by the collaboration of the agents [10].

A finite time formation control framework is proposed by Xiao, Wang et al. Performing formation control by some global information, communicated to some "leaders", by using distributed local information sharing, time-invariant and variant formation control and trajectory tracking is achieved and proven by simulation [83]. In the case of this research global information will be given to a dispersed network of FSCs. However since the amount of co-operating agents is relative low, all will be considered leaders and receive global information.

Within formation control there are 3 distinguished types by Oh et al. [55]:

- Position-based
- Displacement-based
- Distance-based

For position-based control more advanced sensing capabilities are required, Distance-based control, however, demands more interaction between the agents. Displacement-based is a mediator when it comes down to sensing capabilities and interaction necessities. Distance-based control has the advantage that less global information is needed, however, stability issues arise when trying to perform distance-based control [55]. In this research no actual sensory equipment or information loss issues will be presented, therefore a distance-based way of control is implemented, where relative positions are calculated.

A classical flocking model proposed by Reynolds consists out of 3 heuristic rules [57]:

- Cohesion: Attempt to stay close to nearby flockmates.
- Alignment: Attempt to match velocity to nearby flockmates.
- Separation: Avoid collision with nearby flockmates.

When talking about multi-agent systems, consensus is an important part when trying to realize flocking. The basic idea of a consensus algorithm is to impose similar dynamics on the information states of each vehicle[60]. Put differently, In networks of agents (or dynamic systems), consensus means to reach an agreement regarding a certain quantity of interest that depends on the state of all agents. A consensus algorithm (or protocol) is an interaction rule that specifies the information exchange between an agent and all of its neighbors on the network [56].

Mastellone et al. have implemented a multi-agent controller to achieve collision avoidance, trajectory tracking of multiple robots. Also, formation control is successfully implemented to change formation during path tracking, advised is to consider more physical systems and complex dynamics implementation [51].

In the paper of Olfati-Saber more theorem to create a good functioning flock, without fragmentation of the flock. The first algorithm encapsulates all 3 basic "laws" of Reynolds [63]. Then a second algorithm is developed, adding a navigational feedback agent into the flock, the feedback says something about the objective of the group, informing all flock members about the goal. Now decent flocking behavior is established. At last a third algorithm incorporates obstacle avoidance and split/join manoeuvres [57]. Su, Wang, et al. proves that concerning the second algorithm of Olfati-Saber not all members of a flock have to be informed by the navigational feedback function to ensure flocking and adjust the algorithm by changing it and introducing a center of mass approach [69]. Concluded is that the larger number of flocking members, that smaller fraction of informed members are needed to guide the same amount of members to the correct velocity.

How does one design consensus protocols that not only account for control input constraints but also make use of system dynamics to converge on an optimal solution concerning an objective? and how do we make the team objectives invariant for the consensus-seeking problem? In other words, as consensus is being formed, the agents must act on the best information available to them at the time. One way of viewing this is that the individuals understand the team objectives differently. Under what conditions will the "design" objectives be satisfied [80].

A decentralized navigation function is proposed to drive each agent of a group toward a desired final configuration which is expressed in terms of distances between the connected agents. The formation can be reached anywhere in the space and with any orientation. The navigation function assures to avoid collision between the controlled agent and the other agents and obstacles [21].

Wei Ren first researched consensus algorithms with constant reference state, thereafter proposed and analyzed algorithms so that consensus is reached on a time-varying reference state. The consensus algorithms have also been extended to achieve relative state deviations among the vehicles. These consensus algorithms are also extended to achieve relative state deviations among the vehicles. An application example to multi-vehicle formation control is given as a proof of concept [61].

Egerstedt and Hu propose a model-independent coordination strategy for multi-agent formation control. The problem is defined by a formation constraint in combination with a desired reference path for a nonphysical, so-called virtual leader. We show that if the robots track their respective reference points perfectly, or if the tracking errors are bounded, the method stabilizes the formation error [29].

Consensus algorithms have been applied to two cooperative control problems including rendezvous and axial alignment. The experimental results of both applications on the MASnet platform have demonstrated the effectiveness and robustness of the consensus algorithms to distributed cooperative control [62].

The reasons to choose a MAS approach for the development of computer systems are the following:

- Complex: The processes have a large number of different behaviors.
- Modular: The processes can be decomposed into several natural modules (physical or functional modules).
- Changeable: The process may have to be changed frequently.
- Decentralized: It should be possible to decompose the application into autonomous stand-alone processes.
- Ill-structured: Knowledge about the process as a whole may be incomplete or impossible to achieve.

The SCM includes most of the characteristics quoted above: a supply chain is dynamic, complex and large processes, spatially distributed and changeable in a dynamic, fragmented and global world. Thus, it can be said that the problems related to the SCM tasks fulfill the requirements for a successful MAS application. However, understanding how to model, design and control e-logistics is fundamental to the productivity and competitiveness of future manufacturing and logistics systems [25].

2.3. Conclusion

This chapter explores the different faces this research has to cope with. Supply chains overall are discussed, by evaluating different scientific papers and business documentation. There is no overall consensus about what a well-performing supply chain is and how this supply chain should be designed. This is related to the widely varying amount of demands and boundary conditions a supply chain can have in a different environment. Multiple techniques and solutions for supply chain analysis are presented. Also, some optimization techniques in scientific literature specified for military applications are presented. Robustness is also discussed, different definitions and specific methodologies to improve robustness presented, although most of them are policy-based, some interesting options are passed in review. In the second paragraph possible modeling and simulation techniques are stated. Different modeling structures and their pro's and cons are presented. Presented are straightforward "spreadsheet" calculation methods, mathematical modeling and dynamic modeling techniques. This is followed up with an approach on when best to use a certain modeling method and an approach on how to compare results of the models. Truck platooning is the next topic since this research will try to incorporate truck platooning into our model. To do this, the possible effects of platooning in a supply chain should be clear, and see the shortcomings or possibilities

of this new research topic. The most promising technologies enabling truck platooning and certain advantages of truck platooning are presented. The main issues that are experienced are stability issues when trying to control a platoon, most of them related to communication delay and maintaining correct spacing. At last multi-agent systems are discussed. In the research, networked operations are going to be investigated, therefore it is good to know how agent-based control in networks are realized. This networked operating is performed by mobile supply centers. A lot of research is performed about MAS dynamics, including swarming a very potent method of controlling MAS movement.

Findings of the literature research are:

- Supply chain
 - The research has to cope with high uncertainties in the model, therefore an agile supply chain model is needed, to deal with hefty fluctuations in the model. Agility is created by adding some redundancy in the system.
 - Robustness is often defined as a reactive and adaptive supply chain, easy to cope with fluctuations by having high modularity. Adding modularity in a dispersed supply chain network will probably aid in this goal.
 - Important indicators found often in literature are: stock level, order fulfillment and lead times. High stock levels, gives redundancy, short lead times ensure quick responses to changes.
 - Comparing supply chain performances can be done by tracking the KPIs and compare as-is designs versus to-be design of the supply chain under certain scenarios. For a better understanding of the whole system, a sensitivity analysis is useful as well.
- Modeling
 - Advised is an object-oriented approach using a discrete-event model to enable processes and interaction between agents. The object-oriented approach is a natural way of creating a DES.
 - Simulations are quite useful for further verification of the model and increasing credibility.
- Truck Platooning
 - Truck platooning is still being developed by major car companies or large research projects, funded by governments. Still, instability issues occur and speeds are relatively low. Successful tests so far, are with at most 10 trucks in a platoon.
- Multi-Agent Systems
 - A lot of varying methods of multi-agent systems implementations are found in literature. For this model however a distance-based, de-centrally managed MAS network seems relevant, for simulating the "Notice to Move", due to less complexity.
 - When trying to emulate the dispersed network in supply chain operations as proposed by the DoD, the implementation of flocking algorithms seems an excellent fit for this research.

Sub-Question 1:

What are the criteria for a robust supply chain in military environments and how to compare those criteria?

Answer:

Important criteria for robustness are: 1. Stock levels, 2. Order fulfillment and 3. Lead times. Therefor these criteria will be monitored in the model and defined as KPIs for this research about robustness.

As-is design of the supply chain versus multiple To-Be designs will be tested in the model under certain scenarios that stresses the KPIs. for better understanding a sensitivity analysis will be performed as well.

3

The Military Supply Chain

3.1. Introduction

This chapter discusses and explores supply chains in a military context, closely related to the supply chain of the RDLF. To better understand the supply chain as a whole, all assets that are involved are mapped out and described in more detail. Also, some further elaboration of the scoping of the research is done, to support the decisions made for further modeling. First, the whole supply chain is briefly looked at. Then further zooming in at the relevant part of the supply chain for this research. While zooming in, the descriptions will become more detailed. Further down this chapter, the attention is shifted towards the actual transportation processes of supply in the supply chain.

The chapter will answer the second sub-question of the research.

How is the supply chain of The Royal Dutch Land Forces designed?

At last, the chapter is concluded with an overview of all findings and an answer to the sub-question mentioned above.

3.2. The Generic Supply Chain Design

Lets start with presenting an image of the overall design of the supply chain, this image already passed by during the introduction, however in this chapter we dive a bit more into it, image 3.1 shows the so-called "Generic Supply Chain Design" of the RDLF covers the whole logistics supply chain from supplier up to consumer. The suppliers can represent factories or large retailers, consumers are the actual units field during operations. The generic supply chain can be considered as the foundation of a house, the general outline is dictated by this form, however, the actual way of deployment is build upon this logistics foundation.

As can be seen, the image contains 4 major displacement section:

- National Displacement: All logistics that are taking place in the homeland.
- Strategic Displacement: Concerns mainly logistics that are going cross the border, typically long displacement
- Operational Displacement: All logistics in the area where the operation is performed, typically a host nation.
- Tactical Displacement: This is the actual displacement concerning operations at unit level.

Although the displacement sections in the image are drawn next to each other, indicating they are operating an equal same displacement "magnitude" level, every displacement-section step to the right, is towards a lowering magnitude level, getting more detailed and "closer to the ground". It can be seen as a staircase that is lowering in magnitude but increasing in detail 3.2.

For the sake of convenience; at national displacements total distances covered can be up to a multitude of 1,000 kilometers (total distance covered by all moving logistic elements in the

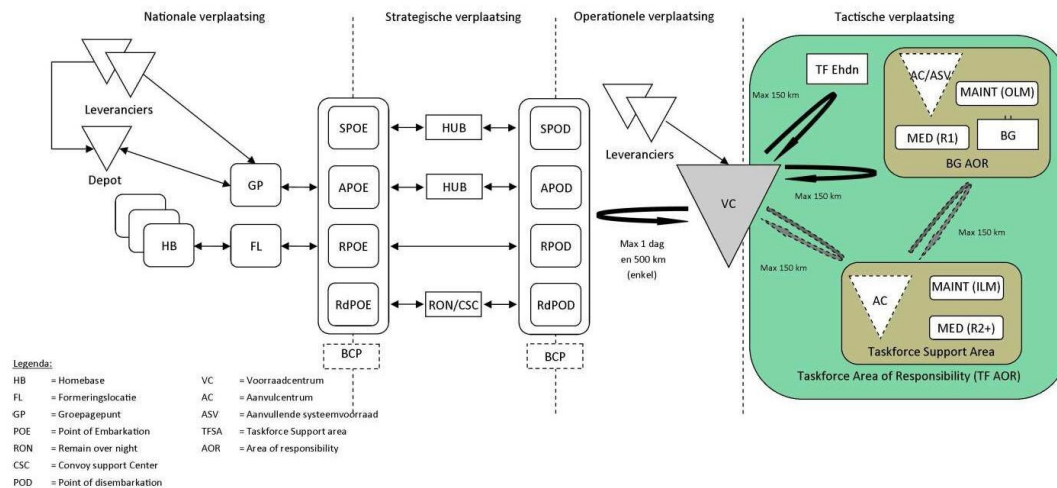

Figure 3.1: Generic supply chain of the Royal Dutch Land Forces.

area), strategic displacement is often about up to 1,000 kilometers, operational displacement has a typical distance of 500 kilometers, and tactical has a typical distance of 150 up till 300 kilometers. As for detail level, national displacement concerns large amounts of clustered supply moving in bulk, when going down the chain up to tactical displacement, very specific amounts of selected supply, need to arrive time, at the right place. From a detail perspective, logistics become more complex.

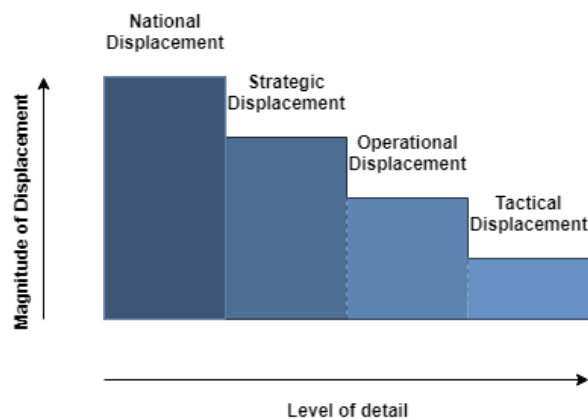

Figure 3.2: Image of a representation of each displacements section in magnitude of displacement and level of detail.

3.2.1. National Displacement

As the name of the displacement section displays, it concerns all logistics in homeland area. In this area important elements of the supply chain are:

- Home bases: These are mainly barracks, proving the manpower to be sent abroad.
- Formation locations: Formation locations groups all units that deployed. When deploying units a customized combination of elements of the RDLF is created, that is best suited for the operation itself. the different manpower elements from all home bases are combined into formed units, of in a combined arms style and made ready for transport.
- Depot and Suppliers: Depots are quite straightforward storing locations for materiel and supply. When needed for an operation these are extracted from the depot. If DoD needs a material that is not in a depot, suppliers provide those directly. Long term contracts are made to ensure supply, especially with a supply that is unpredictable in behavior, like munitions. The image suggests that all suppliers are within borders of

the homeland, this, however, does not need to be the case.

- Grouping location: Mainly material and supply are clustered and made ready for long-distance transport in these areas.

One can notice that most of the logistic movement in a national displacement section is meant to centralize all resources, manpower, materiel, and supply into one location. Its main task can be considered as preparing resources for transportation and quality checking these resources.

3.2.2. Strategic Displacement

The goal of strategic displacement is transportation over larger distances. This is often done by train, plane, and ship. Occasionally road transport is used, depending on the actual distance and infrastructure facilities. The main elements in this section:

- Point of embarkation (POE) and POD: are located in strategic displacements. POEs are locations where all resources are transferred from one displacement section to another, often a cross borders operations. Typical POE locations sea-(s) and airports(A), railway stations(R) and road stations(Rd). The same is for POD, except that resources are loaded off the means of transport.
- HUB, remain over night (RON), Convoy Support Centre (CSC):

3.2.3. Operational Displacement & Tactical Displacement

These two sections of displacements are combined into one sub-chapter because it concerns the areas interest of this research. Operational and tactical displacement are typically in a host nation, or conflict area. Important elements in this section are:

- Local Suppliers: Products that are easy to transport in bulk, have high consumption volumes can be supplied by local suppliers. Typical elements are water, oils, and fuels.
- SC: A central storage facility that receives supply from the POD. Transport between POD and SC happens mainly by truck and standardized containers. At the SC the containers are unloaded and supply is stored in clusters. These can be considered as smaller areas dedicated to a particular type of supply. From the SC supply is transported further to an FSC or unit. Documentation and inventory management are located here as well, coordinating all supplies to a unit in field. From here on transportation to units is being done by flatracks, that can be loaded up to a truck, instead of a container. A SC also facilitates quality checks and safeguarding of supply if necessary.
- FSC: When needed a FSC can be deployed further down the supply chain. FSC are smaller storage facilities, often allocated to a specific unit, in time when a daily resupply cannot be assured by direct supplying from SC. It is dependent on many factors, for example, treats, weather or terrain condition. a rule of thumb is that at least a 24 hours resupply cycle must be made with the unit. Distance-wise a FSC is deployed if the units are located between 90 kilometers and 150 kilometers from the SC.
- Battle Group (BG): This is the actual unit in the field, BG is a general term for different sized deployed units. Units consume supply, it is essential the BG is well supplied, so it can pursue their mission unhindered. For the RDLF a maximum deployment of 3 battalions is relevant for research.
- Addition Stock (ASV): Additional stock (ASV) is assigned to a unit to increase short term supply levels.

Above describes a relatively concise overview of entities that are relevant for this research, during actual in-field operations, numerous processes and entities are involved, like maintenance depots, medical centers, dedicated artillery batteries, maintenance, and reconnaissance units, to name but a few. These are left out of this research though. In table 3.6 all entities are briefly summarized and attached to their corresponding displacement sections.

Current Supply Chain Design

When taking a closer loop at operational and tactical displacements. The major elements that are of interest are:

- Point of disembarkation
- Supply center
- Forward supply Centre
- Battlegroup

As stated before, the point of disembarkation delivers supply by truck daily. Trucks are manned by a driver and co-driver and at this trajectory, trucks are loaded with standard 20 ft containers to the SC. A maximum allowed distance of 500 kilometers between POD and SC is imposed, this can deviate a bit and depends on local circumstances. At the SCs the containers are unloaded and supply is clustered together per supply type, section 3.2.5, elaborates more about the different types. The deployed BG consumes supply every day and when supply reaches under a certain stock level, new orders are created. The unit needs to be resupplied at least every 24 hours. The maximum distance between SC and unit is about 150 kilometers. If needed a FSC is deployed, to support the supply chain and enable this 24-hour resupply move. The FSC receives supply from the SC and is linked to a specific unit. During interviews several of several SMEs, there seemed to be no real consensus what the maximum distance between unit and FSC is, some indicate 90 kilometers, others claim 150. This research uses 90 kilometers as a maximum distance. Image 3.3 shows an illustration of the current model.

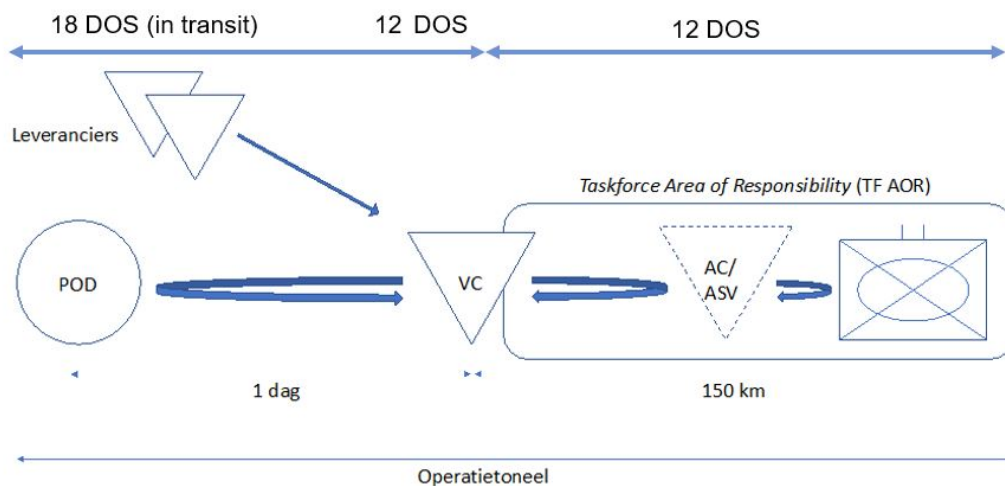

Figure 3.3: A figure of the current supply chain design at operational and tactical level of the DoD.

In figure 3.3 above the supply chain the amount of Days of Supply (DoS) is displayed. In the supply chain 12 DoS is distributed along the elements of SC, FSC and BG, 12 DoS located from POD up to FSC and 18 DoS further in transit, these represent the stock levels that are desired along the supply chain. The exact definition about DoS will be explained further on the report.

When looking at the arrows of supply direction, one can notice a pull-push-push driven configuration. Meaning that a SC requests a certain amount of supply before the supply flows to the SC. From the SC onward, supply is pushed once every 24 hours. The supply chain is thus predominantly a push system, supply is pushed once every 24 hours to the BG, this can and does often result in what some call "steel mountains", where there is a certain overflow of supply at the end of the chain. The RDLF has some minor experiences concerning this problem regarding the water supply.

The FSCs can be considered as mostly supply on wheels. However, a FSC is still quite voluminous and thus less mobile, when needing to relocate.

Conceptual Supply Chain Design

To cope with the ongoing developments in warfare and increase of threats, the DoD is investigating the possibility to worked in a more networked, distributed mode. The networked idea was partly investigated by D.P.A. Claus. Claus investigated the last mile distribution is fitted to support dispersed operations of a brigade. Concluded was that there is a need for flexibility, responsiveness, but mostly robustness [19]. A general idea is displayed in figure 3.4. Expected gains are: less impact due to distributed supply across multiple smaller FSCs and higher mobility. On the other hand, it does increase the complexity of the supply chain. Complexity is generally less favorable during operations but could be worth the possible increase in supply chain robustness. Multiple smaller FSCs are the main game changer for the RDLF. Further, it is noticeable is a multitude of deployed FSCs and the possibility of supporting multiple units with one FSC network.

Also, some changes concerning the pull-push-push driven to a pull-pull-push driven supply chain can be seen. During interviews, it became clear that the supply links between FSC and units are preferably pull-driven as well. In literature, the advantage of a pull driven supply chain driven supply system is a more lean supply chain, reducing inventory stocks. A lean supply chain is definitely not a requirement in this case. The RDLF prefer an agile chain with some redundancy in stock levels instead of a lean supply chain. Otherwise, a lean supply chain means a reduction in inventory. This can result in a more adaptable and responsive supply chain. The FSCs are in the new scenario fully executed as mobile stocks, this is indicated in figure 3.4 as the small wheel below the FSCs. The demand of the DoD is a notice to move of at least 3 hours, meaning that FSCs should relocate every 3 hours to a new position to prevent being taken out. Achieving this high level of mobility is only possible when FSC stock levels are not too high.

When looking at the DoS levels along the supply chain, 3 DoS are assigned to units, 4 to the FSCs and 5 to SCs. The total amount of DoS in the tactical displacement is some halved in dimension. The amount of DoS in transit is unchanged.

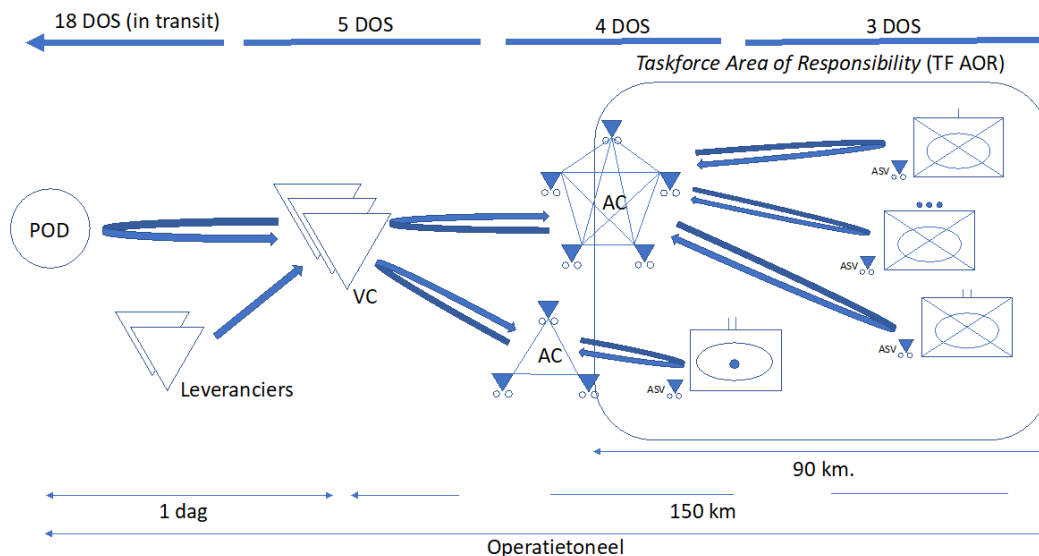

Figure 3.4: A figure of the conceptual supply chain design at operational and tactical level of the DoD.

3.2.4. Means of Transportation

It is essential to know what means of transportation are involved when performing transportation processes. To make transportation easy, a standardized and modular mean of

transportation is desirable. This is the reason a concept is introduced named 'onafhankelijke lastdrager concept' (OLC), in English 'independent load carrier concept'. Resulting in the independence of means of transportation and load carriers, in other words, modularity. This resulted in the adoption of the flatrack and implementation of a WLS at each truck.

- Truck equipped with a WLS: All trucks are equipped with a so-called "Wissel-Laad Systeem". The WLS is a piece of equipment that enables the truck itself to perform unload and load actions, it can be seen as a small crane installed at the truck. The advantage is a fast and modular loading and unloading system, that does not need other equipment. The WLS is mainly used to load flatrack and containers. In table 3.1 the specifications of the Scania are listed.
- Flatracks: A generic platform that enables the storage of NATO- and EURO-pallets. It is the same idea of a container unit, standardized and easy to handle, but a flatrack is adapted to the military context in a sense that a flatrack is easily accessible. The flatrack enables a truck to move with a higher degree of freedom in a less developed infrastructure. A typical flatrack has dimension length, width, and height of 6.61, 2.53 and 2.27 meters respectively and weights 1720 kg. Giving a maximum storage capacity of around $38 m^3$. The types and dimensions of pallets are shown in table 3.2. A flatrack can store 2 NATO pallets in width and up to 5 in length, giving a storage surface of $12 m^2$. If stacked, maximum 2 layers for stability reasons, the total storage surface is $24 m^2$. of the total surface is available if stacked up to 1 meter gives a total of $28.89 m^3$ volume. During operations, euro pallets are used and never stacked because of accessibility reasons. Volume capacity is therefore set at $7 Pallets * 1,2 length * 0.8 width * 1 height = 6.72 m^3$.

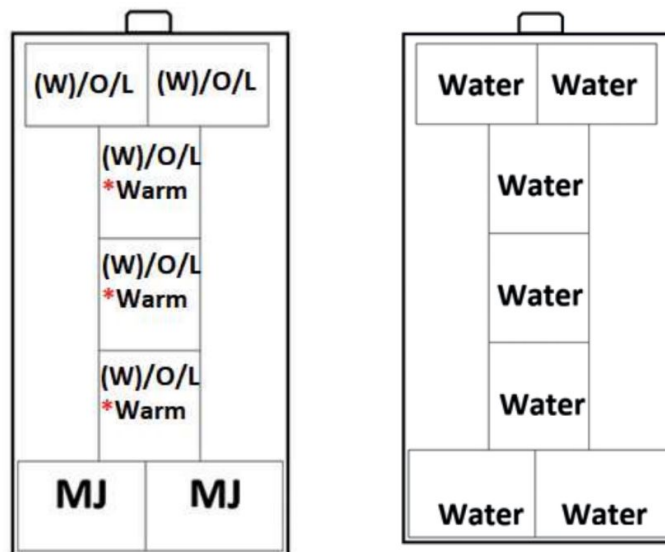

Figure 3.5: Image of 2 possible load-out combinations of one level stacked flatracks. This configuration shows flatrack load-out with possible workspace.

For POD-VC movement mainly containers are used for transportation. These are the well-known standardized sea containers. Heavy transport capacity is used for tracked, mostly armored, vehicles. Heavy transport is performed by the TROPACO, an abbreviation for "Trekker-Opleg-Combinatie" or "Truck-Trailer-combinatie" and most of the time only between POD-VC trajectory.

1. Containers: These are the well known 20' or 40' and less known 10' containers that are used to transport almost every supply type from POD to SC, however containers can also be used between SC and ac/units, for more specified application like a satellite kitchen,



Figure 3.6: Figure of truck equipped with WLS handling a container unit.

storage for spare parts or again transport of bulk materials. Container transport is less suited for areas between SC and units due to the lack of infrastructure. 20 ft container weights 21,720 kg



Figure 3.7: Figure of a truck equipped with a WLS, handling a container unit.

2. Heavy transport capacity: A truck-trailer concept, used for transportation of heavy equipment, mainly armored or tracked vehicles and self-propelled artillery. This trailer supports the extra weight capacity needed and enables a truck to reclaim damage vehicles needed for repair and transport them to a garage.



Figure 3.8: Figure of a truck equipped with WLS and TROPACO, used for heavy equipment transport.

As this paper focuses more on the trajectory between SC and units, the container application will be neglected, due to limited usage in the trajectory of our interest. The heavy transport usage is also a lot less compared to flatracks, and will mainly be used for retraction

Table 3.1: Table with specification of the Scania 165 kN WLS.

specifications	Scania 165 kN WLS
Average velocity	90 km/h
Amount	295
Crew	5 (2 drive + 3 passenger)
Engine	DC12-01, 6 cylinder TD, 420 hp at 1900 cycles
Dimensions(lxwxh)	9.86m x 2.54m x 4m
Action radius	800 km/400 km
Max load cap	16.500

Table 3.2: Table of 2 types of pallet sizes

Pallet Type	measurements [mm]	Minimal capacity [kg]	Minimal capacity (stacked) [kg]
NATO-pallet	1200x1000	1000	4000
EURO-Pallet	1200x800	1000	4000

of damaged or vehicles that are out of use. Since this report does not incorporate the supply chain for revisions and repairs, heavy transport capacities will also be neglected. When equipment is transported at flatracks, there is either a specialized flatrack available, like for water tanks. If the equipment is packed in a break-bulk manner it is stacked at pallets. Pallets have a certain capacity for storing as displayed in table 3.2.

To determine the number of vehicles N_{plat} needed in the convoy, we need to be able to calculate the volumes that are ordered when handling 1 DOS of supply for a unit and know what volume can be taken with us in a flatrack.

Table 3.3: Table of quantities, subscripts and units involved in calculation of days of supply.

Quantity	Units	Explanation
V	$[m^3]$	Volume
DOS	$[-]$	Day of Supply
N	$[-]$	Number of persons
m	$[kg]$	mass
ρ	$[\frac{kg}{m^3}]$	Density

$$V_{DOS}^{unit} = DOS_{ord}^{unit} * N_{pax}^{unit} * \sum_{i=1}^n \frac{m_{DOS/pax,i}}{\rho_i} \quad (3.1)$$

The volume of a flatrack that is completely loaded has a capacity equal to $6.72 m^3$, this results in a total amount of trucks, needed for transporting the requested supplies.

$$N_{WLS}^{unit} = \frac{V_{DOS}}{V_{flat}} \quad (3.2)$$

It could be possible that multiple units order at an SC or FSC, the sum of the volumes of all units will define the total amount of trucks that is needed at that location.

$$N_{WLS}^{tot} = \sum_{j=1}^n N_{WLS}^{unit=j} \quad (3.3)$$

3.2.5. Supplies of the Royal Dutch Land Forces

This subsection discusses supplies that are used within the RDLF supply chain. In a military context, types of supply are called classes and quantities of supplies are expressed in DOS.

Table 3.4: Table of sub- and superscripts used for truck usage calculations.

Sup/Superscripts	Explanation
dos	Day of Supply
flat	flatrack
i	Type of supply
j	Type of unit
ord	order
pax	amount of persons
wls	Wissel-Laad systeem or truck

Day of Supply

A DOS is defined by NATO standards and comes down to the following definition:

The volume of supplies a battle group consumes each day in order to perform its prime purpose.

The volume of a DoS is defined per BG size. Thus when talking about a DOS per unit, one DOS can differ in volume and weight. For example, when a battalion (600 Person(s) (PAX)) orders one DoS, the volume and weight of supply is way less compare to a brigade (2200 PAX) ordering one DoS. So when looking at our supply chain, the sum 3 DoS for each deployed unit is equal to 3 DOS stored at a FSC. Now it makes sense that a 24-hour resupply action is the basis of this supply chain. Each unit consumes one DoS a day. According to a protocol, a unit needs to be re-supplied that day to fill the stock levels back to 3 DoS in total. This means that the supply flow from SC/FSC to that unit is 1 (unit-)DOS, however in volume is $\frac{1}{3}$ of the total volume stored in the SC. Stock levels indications are developed, that are associated with a certain state and coupled to certain actions. The different supply levels are shown in figure 3.9 and explained in decreasing degree as follows:

- *Maximum supply:* The maximum supply that can be held.
- *Warning supply:* Requires actions to request a resupply action to resupply to a maximum level, at this point 2 DoS is left in stock for the unit.
- *Safety supply:* Meant to cope with fluctuations in delivery and consumption.
- *Minimum supply:* The supply level that demands action for rationing/prioritizing to continue the essential processes.
- *Disturbance-supply:* Back-up supply for discontinued deliver supply, around 1 DoS.

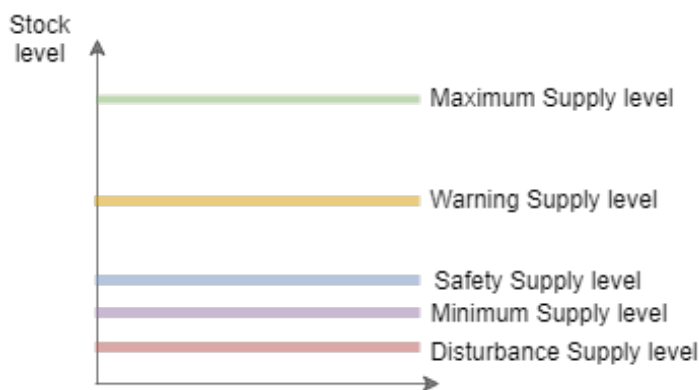

Figure 3.9: Figure of the different stock level indicators of supply. The actual volume differs per unit size, so no standard amount can be specified in this figure without knowing what unit is deployed.

In this research we limit the different supply levels according to these three values:

Full stock = 3 DOS

Average stock = 2 DOS

Low stock = 1 DOS

Full stock level is the ideal situation, however, units order new stock around when their own stock level is around 2 DOS. This would mean that on average 2.5 DOS is in stock. Thus 2.5 is considered excellent in this research. Average stock levels between 1 and 2.5 DOS are considered sufficient. Stock levels below 1 DOS are considered critical. Now it is clear what defines a DOS when it needs to be reordered, the different types of supply in the supply chain are elaborated a bit more.

Types of supply

During military operations, a wide variety of supply is consumed in large quantities. Each having different sizes, weights, and purposes. For the RDLF the amount of supply is tailor-made for each mission type. Supply can appear as ammunition crates, drums of oil, flatracks of potable water, large construction materials needed for preparing defenses, spare parts, equipment, clothing and so on. This section discusses how supplies are organized in such a substantial supply chain.

The Royal Dutch Land Forces use the supply structure defined by NATO documentation, which is widely accepted among other NATO members. In general, 5 different supply types are known. These are listed below:

1. Class I: Means to support life, this class includes all life essentials, water, and food for humans and animals. The consumption of this type of supply is quite uniform and lightly dependent on the local (combat-)scenarios. It is a class that is very predictable and volumes can be easily estimated. Class I has 4 sub-assortments:
 - Operational Rations
 - Prepared meals
 - Canteen goods
 - Drink-water (bottled, bulk)
2. Class II: Equipment authorized by the state. This type involves weapons, clothing, tools, and spare parts. This type of supply does have a larger dependency on (combat-)scenario and environmental circumstances. A higher consumption rate is known when being engaged or engaging. Besides a volatile fluctuation in demand, it is hard to predict volumes of class II, due to the dependency on what kind of missions are to be expected.
3. Class III: This class includes fuel, oils, and lubricants destined for all kinds of purposes during operation, except for aerial purposes or specific weaponry; like flamethrowers. Environment factors have their influence as well, equipment like stationary motors, aggregates and heaters need fuel. Class IIIa involves fuels, oils, and lubricants specific for aerial means. In this research, the aerial factor is not considered. Class III knows a higher consumption rate fluctuation and is therefore not as predictable as class I. If consumption is known, volumes estimations can be relatively accurate. Class III sub-assortments are:
 - 3.1. Bulked Fuel
 - 3.2. Fuel in jerrycans
 - 3.3. Oils, lubricants, chemicals and maintenance goods
4. Class IV: Supply types involving products that need no by state authorization. Mostly fortification and construction materials and administrative features. These supply types can be considered stable in consumption can be predicted quite well. Class II/IV is often combined since it concerns highly diverse and often large packages that are difficult to handle. Therefore a standardized package is composed since consumption is very predictable.
5. Class V: This class is meant solely for munitions, explosives, and chemicals used for combat. Also, the fuel for fuel specified weaponry is supplied by this class type. This

class knows a heavy fluctuation strongly dependent on the (combat-)scenario. The type of supply is a bit more predictable when looking at combat environments, urban combat demands different types of munitions compared to open-field or long-distance combat scenarios. Class V sub-articles are:

- Manoeuvre munitions
- Engineering munitions
- Artillery munitions
- Air defence munitions
- Additional munitions

A general idea of what volumes and weights per type of supply are connected per person is given by table 3.5.

Table 3.5: Table containing staff planning data about weight and volume per supply class per PAX.

Supply Types	Consumption weight [/PAX/Day]*	Consumption volume [/PAX/DAY]*
Class I		
Fresh Ration	3.0 kg	0.01058 m ³
Combat Ration	2.2 kg	0.00776 m ³
Potable Water	9,97 kg	0.01 m ³
Gen Purpose Water	69,79 kg	0.07 m ³
Class II		
Clothing and Equipment	1.65 kg	0.01 m ^{3**}
Vehicle spares	3 kg	0.003 m ^{3**}
Class III***		
FCU	13.84 kg	0.0178 m ³
Lubricant	0.6942 kg	0.00089 m ³
Class IV		
Engineer resources/ Construction	3,85 kg	0.02 m ^{3**}
Class V***		
Munitions, Explosives, Chemicals	3.33 kg	0.025 m ³

* 1 PAX equals one person. ** Assumption made based on interviews. *** Based on estimated NATO numbers of a light brigade. One NATO brigade contains 4500 pax

3.2.6. Delivery Methods

The general form of the supply chain is known, several import entities are discussed, the amount of supply, types of supply and relation with the consumption of the units are clear. The transport modules are also explained, just one last step is needed to completely understand the supply chain, that is the delivery at the end of the chain, there are several methods, each preferred dependent on the circumstances, a different factor can be weather-, speed- or safety issues. A brief overview of delivery methods is listed below.

1. Supply Street: When resupplying using a supply- street, a small detour route is selected, that fulfill the demand of having enough protection and cover. The units that are needing a resupply, drive through a "one-way" street along a row of trucks equipped with flatracks, units can pick up their needed supply. At the end of the supply street, a dump point for return goods or trash is created. Figure 3.10 show a schematic drawing of a supply street.
2. Delta-point: A delta point is deployed behind the line of a company, at a covered, but recognizable location. Here resupplying takes place, where platoon by platoon is being resupplied under the dictation of the commander. Units need to leave their positions for a short time.
3. Dump-points: At dump-point, supply is dumped along a road or specific area. Due to the possible loss of equipment and supply, this technique is seldom used. Also, units need to unload supply themselves, which is less favorable.

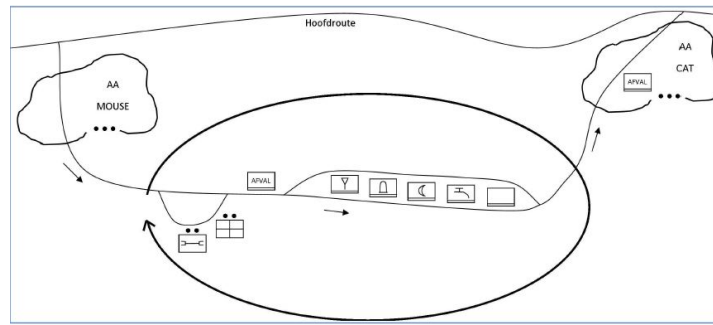

Figure 3.10: Figure of a schematic drawing of a deployed Supply street

4. Gatherings-zone: when units are deployed a relatively long time in a certain area a gatherings-zone is created. Direct resupply from the vehicles to the units is facilitated here, this could be combined with the deployment of a CSC, providing RON and maintenance meanwhile the resupplying is being done.
5. While in emplacement: When resupplying in emplacement, WLS drives by all units while still in emplacement (sort of the counterpart of a delta-point). This takes more time for the means of transportation to do. It is mostly used when units are spread widely.
6. By Air(drop): When the distance to resupply is too large or the resupplying by ground transportation is too dangerous, air resupplying is done. Note: By air is excluded in this research.

3.3. Conclusion

This chapter presents information from internal documentation about the designs of the supply chain of the RDLF. Starting with the general layout of the supply chain ("Generieke Bevoorrading"). The chapter displays the vital entities that are present in the supply chain. Four different displacement sections were indicated, where operational and tactical displacements are the areas of interest for this research. Also, the typical distances, time constraints and differences in designs are reviewed. Table 3.6 presents an overview of entities in the supply chain and gives a brief description.

Besides creating awareness of the entities involved in the supply chain, further matters of importance for operating and establishing a supply chain were discussed. The five classes of supply are reviewed, supply quantities are expressed in DoS, meaning a "Days of Supply". DoS are used for quick calculations in the supply chain. Although a DoS sounds like a standardized unit, the volume of a DoS varies heavily depending on the size of the deployed BG. Also, the means of transportation and some capacity limits, packaging, and delivery methods are briefly discussed.

The findings in this chapter that are relevant for this research are:

- Entities of importance are:
 - POD
 - SC
 - FSC
 - BG
- Typical distance between SC and BG are 150 kilometers, when and FSC is included another 150 kilometers adds up.
- At least every 24 hours a resupply is being done.
- Trucks with an WLS system are considered the main mean of transportation. There are able to equip flatrack, that have a max loading capacity of 8 pallets realizing a transport capacity of $6,72 m^3$ during operations

- 5 Different types of supplies are used in the supply chain, named accordingly class I up to class V.
- A DoS equals one day of supply per specific BG and thus a DoS varies per BG size. Volumes of a type of supply are presented in table 3.5.
- Several ways of delivery are found during supply chain operations, depending on the scenario and environment.

Sub-Question 2:

How is the supply chain of the Royal Dutch Land forces designed?

Answer:

The RDLF design their supply chain according to the generic supply chain model. However, there are many ways of operating this general design. For the part of the supply chain that is being investigated by this research, the supply chain has three main elements: SC, FSC, and unit. The supply chain is considered a linear model, having a three echelon, single tier configuration. However, efforts are made to convert this into a three-echelon, multiple-tiers supply chain.

<i>tier</i>	<i>entity</i>	<i>function</i>
National Displacement	Suppliers/depot	The suppliers and depots are the starting point of the supply chain. Supplies are delivered directly from the suppliers, or if in storage delivered from depots.
	Home base	Home bases are the actual bases with manpower, the barracks of the RDLF, that are dispersed across the country. The units that are deployed are often a combination of multiple companies, belonging to different home bases.
	Grouping location	At grouping location sorting, grouping and packing of all sub shipments are done and made ready for transport.
	Formation location	At formation locations units are combined, materials are made transport ready and documented.
Strategic Displacement	Point of Embarkation	After all units and materials are made ready for transport and everything is documented, the actual shipment starts at a POE. In general, there are four possible POEs; a sea-, air-, rail and road point of embarkation. Depending on the location where the forces are stationed and the available PODs at that location. Materials are mainly transported in containers or specialized bulk handling equipment.
	Point of Disembarkation	Concerns the same concept as a POE, for disembarking all units and materials.
	HUB / Remain Over Night / Convoy Support Centre	A Hub is a strategic point that enables a transfer of materials or units this could be a transfer between means of transport or modality. Remain overnight are time and location bounded necessities for long-distance transport. A CSC and RON can be deployed, these offer services like maintenance, resting location, resupplying or safeguarding.
Operational Displacement	local suppliers	The same as the standard supplier at national displacement, except located at or around the area of operation. Often supplies like potable water, oils and fuels (many in bulk) are provided from local suppliers.
	Supply Centre	This is the central storage location at operational level that collects all supplies from the POD. The maximum distance between a POD and SC is one day traveling, or 500 kilometers, this depends on the quality of the infrastructure. At the SC containers are being unloaded and supply, often placed at euro pallets, is being stored per type in so-called clusters.
Tactical Displacement	Forward Supply Centres	Can be considered as a smaller, pushed forward, SC. A FSC is being deployed whenever time or distance factors demand this, to ensure once a day resupply at unit levels since potential threats and environmental factors can delay convoy speeds significantly. Next to reassuring daily resupplying, a medical or maintenance station can be deployed around an FSC.
	Battlegroup	The BG is the end user or consumer that demands this whole supply chain. A battlegroup can exist out of several units. The supply chain needs to ensure a 24-hour resupply cycle, to let the BG pursue its mission.
	Addition Unit stock	This can be considered as a small detachment of mobile supplies that is assigned to a unit that needs additional supply to ensure continuation of their operation. It's an extra buffer, often kept mobile in trucks with flatracks. A possible reason for an additional unit stock is when units are advancing of heavy resistance is expected. Also when the battlegroups contain some heavy self-propelled artillery the standard amount supply of supply that is carried along with it, simply isn't sufficient.

Table 3.6: A brief overview of entities in the SC of the Royal Dutch Land Forces. A small description of its main function and constraints are explained.

4

Truck Transport during Military Operations

4.1. Introduction

This chapter will elaborate more on truck transport procedures used for military situations. Relocating supply during military operations happens mostly in convoys. Convoys ensure orderly transport by road and often have a security element accompanied for protection. Subsequently, a closer look is taken at the truck platooning knowledge gained by literature review in chapter 2. Thereafter some concluding remarks are made concerning the effect of truck platooning in convoy style procedures.

The sub-question that is to be answered by this chapter is:

What effects does truck platooning have in a military supply chain context?

4.2. Convoy Styles

One definition of a convoy that is given by internal documentation of the DoD:

A number of vehicles, who moves under a hierarchical command along the same route at the same time in the same direction. A convoy can exist out of one or multiple elements, that can be indicated a marching unit, convoys or packets.

Convoys are made up out of one or more "marching columns". A column in its turn consists out of "serials". A "marching unit" is the smallest organizational element within a convoy. These definitions might differ per organization. Image 4.1 shows a generic layout of a convoy. Convoys can be up to a hundred vehicles long, depending on the mission that is executed and what needs to be transported. Experiences in Mali and Afghanistan did point out that convoys were made as long as possible due to safeguarding requirements. Due to a shortage of personal to guide and protect the convoy, few and very long convoys needed to be created. However, this was during PSO missions, where base-logistics is the standard way of resupplying, meaning once every while, not necessary once a day, a huge amount of supply is transported to the base and kept there for consumption.

When looking at combat logistics context, a convoy will typically be as long as the volume of one DOS that needs to be transported, this is often up to 10 vehicles long, when resupplying at battalion level. This research focuses on units of the size of a battalion. The idea of having multiple smaller convoys is attractive due to reducing chances of being spotted, increased mobility and smaller convoys are less tempting targets. When being engaged, small convoys result in potentially smaller losses.

Convoy speeds are not as fast as a single truck can drive. Due to procedures and control-reasons for convoys, they drive at lower speeds. Of course, during missions, these are strongly dependent on the environment and threat levels. However, some rule of thumb formula is given to calculate the specific average speed per convoy. Since we are looking at

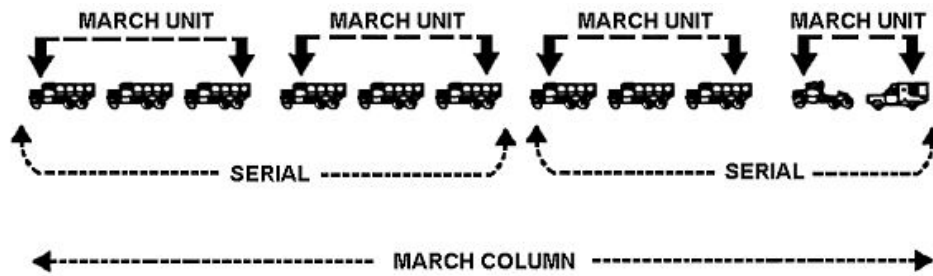

Figure 4.1: Generic design of a convoy. Source: global security.org

Scania's WLS 165 kN trucks as the main element, calculations will be adjusted to that type of truck in the overall research.

Table 4.1: Table showing quantities and units involved in calculation of convoys

Quantity	Units	Explanation
v	$\frac{km}{h}$	velocity
s	km	distance to cover
t	h	time
p	%	percentage for road type
N	[-]	Number of trucks
ρ	$[\frac{kg}{m^3}]$	convoy density

Table 4.2: Table showing subscript used in convoy speed calculations.

subscripts	Explanation
av	average
con	convoy
tr	truck
tot	total
run	per run of a single truck
pass	spacing between first and last trucks to pass a specific point
gap	additional gap between vehicles
halt	time for halts
road	road quality

The average velocity of the convoy, defined as:

$$v_{av,con} = \frac{s_{con}}{t_{con}} \quad (4.1)$$

In order to determine the total time needed to cover a certain distance, several factors are involved, depending on road capacity, number of vehicles in a convoy and convoy density. Halt times are the number of mandatory stops and is calculated as a quarter of time rest per total driving time.

$$t_{tot} = t_{run} + t_{pass} + t_{gap} + t_{halt} \quad (4.2)$$

$$t_{run} = \frac{s_{con}}{v_{av,tr}} \quad (4.3)$$

$$t_{pass} = \frac{N_{con}}{\rho_{con} * v_{av,tr}} \quad (4.4)$$

$$t_{gap} = t_{pass} * p_{road} \quad (4.5)$$

$$t_{halt} = 0.25 * t_{run} \quad (4.6)$$

The distance is known since the destination and origin of the order is given at the beginning of a convoy operation. Often standard convoy velocities are range from 10 *km/h* up to 30 *km/h*. Assumed is that the average velocity of a single Scania is about 30 *km/h* in operations. When the total transport time is known, combined with the distance gives an average column velocity that incorporates time gaps, halts en road capacity.

4.3. Truck Platooning

As could be seen in literature, truck platooning is widely researched lately. Cooperative adaptive cruise control is a much promising technology, that has gotten a lot of attention in the automated truck platooning community. CACC is a sensory-based truck platooning technology and is most likely to be integrated into a military context, when compared to truck platooning technology using cellular network or wifi. This is due to cybersecurity reasons.

In civil industries truck platooning helps to deal with congested roadways, increase driving safety and experience, reduce fuel consumption and cost and results in lowered CO2 emissions [79]. These can be beneficial properties but are certainly not the end goals of truck platooning integration in the military supply chains. The main reason for the DoD to investigate truck platooning is to reduce the number of needed chauffeurs. This is beneficial because of the following reasons:

- Reduction in total drive time per driver: Drivers can take more rest when rotating the main driver of a truck platoon. Besides the state of mind easiness of the drivers is improved, it greatly reduced risky situations like sleep deprivation. In turn, this results in less human errors during convoy procedures. Or:
- Increase of supply chain robustness: fewer drivers needed per convoy, result in a reduction of drivers needed or in operating more and smaller convoys. This indirectly could increase the supply chain responsiveness and adaptability.

According to literature, experiments have proven that truck platooning technology is currently capable of operating at most 10 trucks without experiencing instability issues [15]. In the article of Chen et al., a six truck platoon has a maximum headway speed of 30 *m/s* and experiences positioning error of up to 20% when no large slopes are present when slopes are present in the road this error can increase to around 30%. Operating a truck platoon in a military context, where damaged or bad infrastructure is present, could increase the positioning error. The minimum allowed space-gap is research related to velocity and acceleration capabilities. It comes down to a minimum allowed space gap of up to two meters [66], this is calculated without communication delays and velocity in the range of 20 to 25 *m/s*.

Several successful experiments are performed by major research institutions or companies, specializing in the truck platooning area. A good example is Energy ITS, a project by the Japanese Ministry of Economy tested three platooning trucks that are driving at 80 *km/h*, having a space gap for 10 meters [73]. PATH experimented with an eighth-car-platoon having four meters headway distance in between and a heavy-duty truck experiment having up to 3 trucks having four meters distance.

4.4. Integration of Platooning in Military Context

Since the average speed of a convoy is most likely to be around 30 *km/h*, the speed requirements are met when integrating truck platooning in a military context. There is a limitation set to a maximum of 8 trucks driving in a convoy when truck platooning is integrated into the model. This is not necessarily a problem since smaller convoys are preferred in the new supply chain design. A major benefit could be the elimination of mandatory stops for drivers. When drivers change seats during truck platooning, the elimination of the need for convoy stops would increase the average convoy velocity. Again adding responsiveness into the supply chain. The reduction in convoy size on their turn increases the overall convoy speed as convoy length does impact speed. Another huge benefit is the possibility of a reduction in losses when conflicts happen.

It is important to tell that in this research no effect is done in researching the feasibility of truck platooning, there are many more limitations and complexities involved when implementing truck platooning in a military environment. This thesis only takes into account the possible effects of platooning related to robustness as is defined in the previous chapter.

4.5. Conclusion

In this chapter information about the convoy procedures between SC or FSCs and BGs is stated. First, a closer look is taken to the style of transport that happens in a military context. In the literature study, the benefits of truck platooning in civil industries are shown. The most important benefits were increased safety, improved road capacity and a reduction in fuel consumption. These civil goals of truck platooning are only partly relevant for military usage. The DoD is more focused on using this technology as a solution for relieving the pressure of operating their supply chain. By needing fewer drivers, reduced workloads or improved robustness can be achieved. Also, the reductions of drivers in a convoy will lead to fewer casualties when being taken out. The preserving of chauffeurs will also result in increased robustness, since during operations more will be employable.

Findings:

- Truck platooning is possible to integrate into a military context, when looking at the operation demands of a supply chain. There are of course a lot more complications when implementing truck platooning.
- The overall benefits of truck platooning in civil industries do not apply for military context.

Sub-question 3:

What effects does truck platooning have in a military supply chain context?

Answer:

- Truck platooning in military supply chains might result in a more responsive supply chain, due to the slight increase of average velocity when driving in convoys. This benefit is mainly accountable for the removal of mandatory stops. Platooning limits the sizes of convoys, this is, however, a positive trend. Smaller platoons mean less chance of being spotted.

5

System Analysis and Simulation

5.1. Introduction

This chapter presents the methodology used for creating a framework for a computer model of the supply chain. Literature review in chapter 2 assessed that a discrete event model would be the best manner of capturing the supply chain into an accurate model, that has all the functionalities needed to investigate the robustness of the supply chain in the operational and tactical displacement sections.

Designing a supply chain is a large objective, that can be approached in many ways. A diligent approach is needed to break down the main objective of modeling a supply chain into smaller sub-problems, without losing sight at the actual goal of this report. Important is the level of detail needed, more detailed models are not necessarily better models. Too many details result in complex and incomprehensible models that might not even serve the purpose of the research.

Simulations can greatly aid in verifying the model and is a great way to improve the credibility of the model. Simulation functionalities will, therefore, be implemented in the model. In discrete event packages there exist the possibility to create a real-time simulation, allowing us to observe the model as it runs. This chapter tries to capture the framework for the model, by presenting the development process, implementation challenges and assumptions for the model.

Besides presenting all that is described above, this chapter seeks to answer on sub-question 4:

How to design a supply chain for military operations?

5.2. Systems Approach

Let us first map the whole system into a more clear and precise way. It is important to understand the supply chain system that is being investigated and comprehend the processes of the system. The method selected for the analysis is the "Delft System and Simulation Approach", described in the book of Veeke, Ottjes and Lodewijks [77]. The advantage of this approach is its step by step break down from a global zoomed out view of the system, into a more detailed system. For the sake of clarity; the "system" refers in this section to the supply chain of the RDLF. This step by step approach reveals important assets, processes and links in the system in a more mathematical manner. The method keeps zooming in until the appropriate level of detail is captured. What the actual appropriate detail level is, is left to the judgment of the author.

The supply chain part that is of interest for the black box model involves only the tactical displacement. Therefore a black box representation in this chapter is made just after POD and just after the BG.

First, the system is captured in a general "black box" model as shown in picture 5.1a. Looking at the black box model just the requirement, performance and in- and outputs arrows

are shown. If we dive one level deeper into the function box of the black box model, according to the delft system approach, an information stream and material stream is present, shown in figure 5.1b.

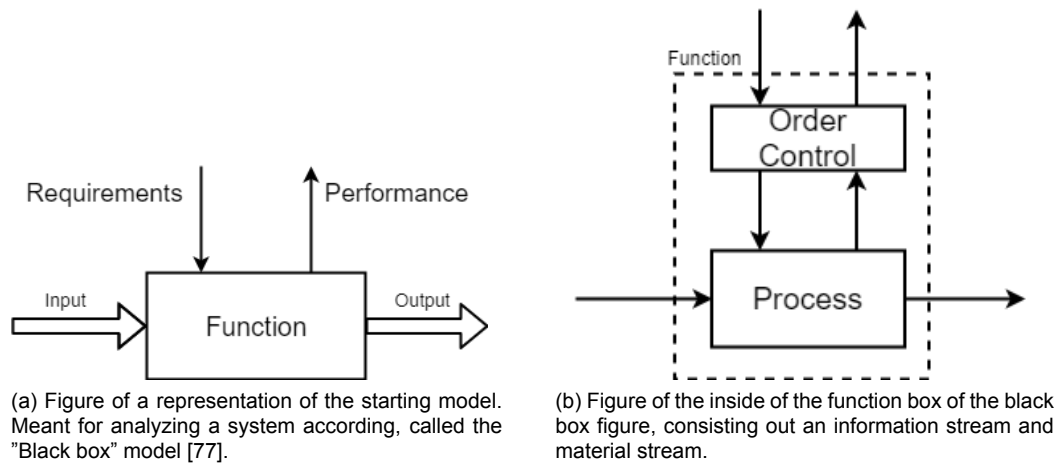

Figure 5.1: Images of representations of the black box model.

The "Black box" model represents the supply chain, where the process or function is the transportation of supply. The in- and output of the model are "supplies" and "consumed supplies". Incoming supply from the POD is represented by the arrow on the left, the consumed supply from the deployed BG is represented by the arrow at the right. Requirements are a robust supply chain, so the systems' requirement is robustness. Performance indicators are, as discussed in the literature review:

1. Stock levels
2. Lead time
3. Order fulfillment

The performance outputs are used to measure up to what level the requirement is achieved. In other words, the KPIs measure the robustness of the system. comparing those KPIs enables us to conclude regarding robustness when the system is subjected to several scenarios. Picture 5.2 shows a filled-in basic black box model.

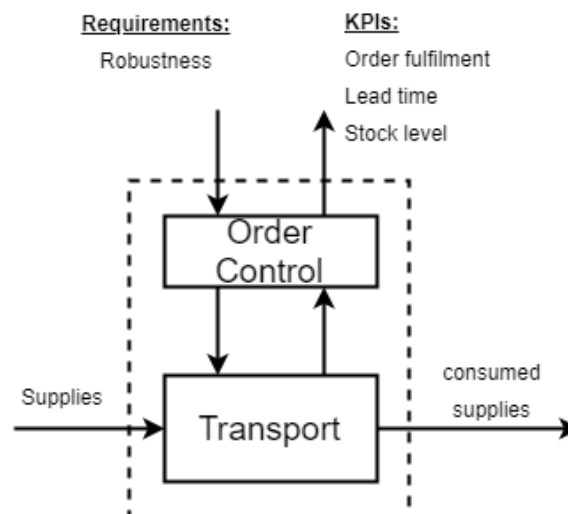

Figure 5.2: Figure of the black box model complemented with some further information.

When zooming a bit more into the transport box, new entities are revealed. Transportation exists out of temporary storing in buffers and movement in between these 2 buffers. The 2 buffers represent the SC and BG. In between, a transportation process links the buffers. The supplies pass through the system as can be seen in figure 5.3.

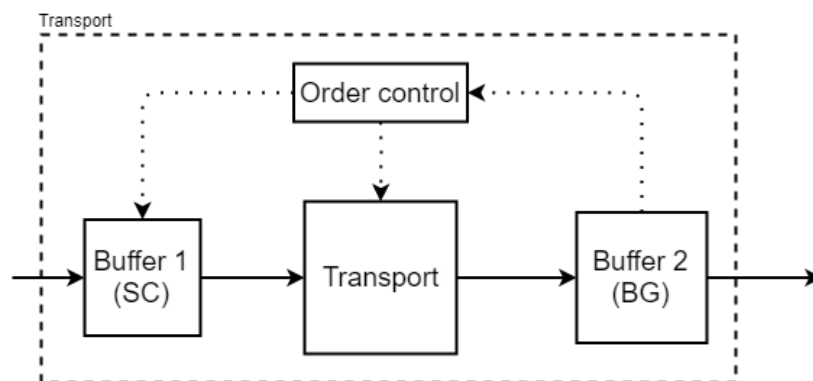

Figure 5.3: Figure of an expanded view of the transport function box and order control.

Zooming in one more level at the sub-transport block, the FSCs are uncovered. Here is the major difference between the old and new model can be spotted. The old supply network only knows a linear stream of supplies, the concept supply chain has a networked behavior. This means that supply can cycle through the FSCs multiple times. It still might be possible to transport supplies directly from the VC to the units, this is why there is a feed-forward loop running above the AC block. At last, it is worth mentioning that the supply chain has a feedback loop containing old supply or material needed for repairs and casualties. This is left out of the scope of this research. The dotted line running from buffer 3 to buffer 2 and 1 is the order information flow. When operating a pull supply chain, this flow originates from the consumer back to FSC and eventually the FSC orders at SC. The order flows directly to SC if no FSC is deployed.

From this point on, it is possible to dive deeper into the separate buffers. Many interesting processes are present in the buffers as well. It will however not be essential to map these processes, because this research is trying to define robustness related to the amount of FSCs that can be deployed. In the context of this research the processes within the FSC, do not matter. This does not mean that investigating the FSCs cannot lead to improved robustness, but that is left for a different research project.

5.3. Modeling Process and Development

The general outline of the modeling process is mapped in this section. What exactly is to be modeled and how to design the experiments performed by this model deliver the right results. Also, the variables and scenarios are discussed. This needs to be clear before starting the creation of the model. An abstract overview of the modeling process is given in figure 5.5.

First testing scenarios need to be developed. The scenarios include a spectrum of variables that will be changed when simulating. It comes down to 3 different variables that are going to be changed during the numerical experiments. Those 3 variable represent the uncertainty in demand and supply that is experienced by every supply chain:

- Link drop-out rate
- Node drop-out rate
- Consumption rate

Link drop-out means a temporary blockage of a supply route. This impedes the flow of material throughout the model. Link-drop rates are expressed in the number of drops per day. Node drop-out target the possibility of elimination of FSC. A node drop-out means large losses in stock levels of FSCs, hindering order processes. Node-drops are also expressed in a number of drops per day. Both link and node drops can be considered aspects of supply

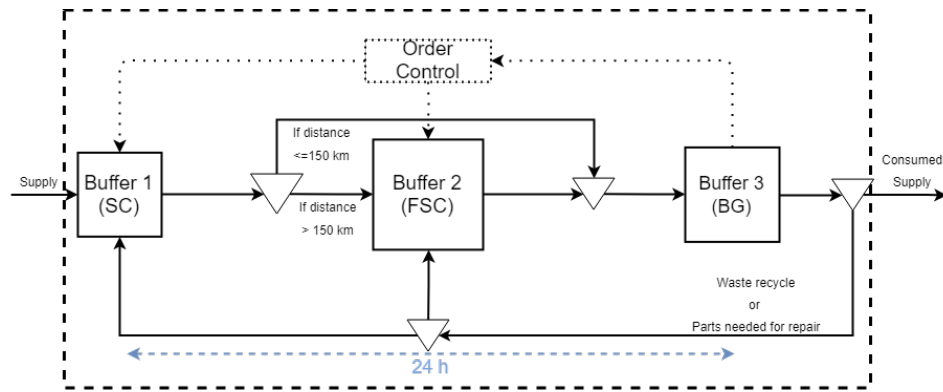

(a) Sub-figure of the linear supply chain model of the DoD, including feedback loop of equipment back to SC or FSC.

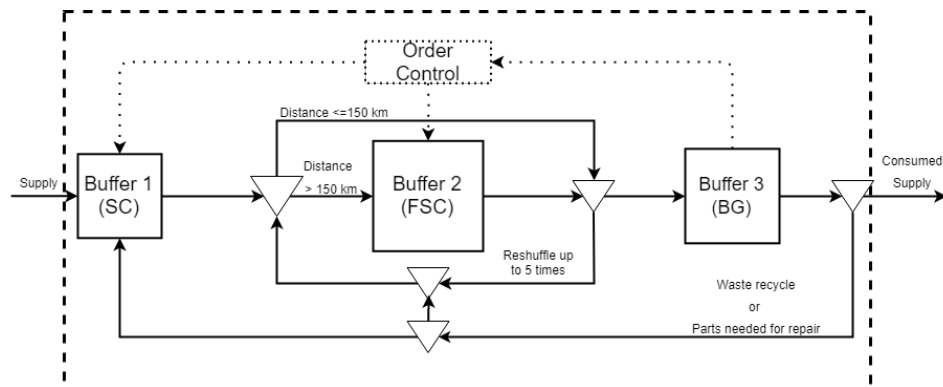

(b) Sub-figure of the networked supply chain model of the DoD, including feedback loop of equipment back to SC or FSC, since at max 5 networked FSCs are investigated, material can loop through at max 5 times.

Figure 5.4: Figures of 2 fully expanded processes of the supply chain of the DoD.

uncertainty. Consumption rate is expressed in the amount of DoS per day, when the BG encounters hostilities or endure harsh environmental conditions, rates might increase. This increase in rate is modeled by a multiplication of the consumption rate with an intensity factor. This results in more pressured stock levels and is considered an aspect of demand uncertainty.

Next is the development of the model itself. We know at what detail level we need to model the supply chain and what entities and processes are involved. Two types of flows have been revealed, a supply flow and an order flow. There is a third flow present in the model, concerning the trucks transporting the supply. However, this flow is not identified in the system approach, since the truck flow is a circular flow inside the model. Trucks enable the process of transportation. The trucks in the supply chain model can be considered as a resource that the order and supply flow use for enabling the function of the model: "transportation".

The computer model itself should consist of 2 sub-modules, one module is concerned with the representation of the different possible designs of the supply chain. This means the variation of FSCs in the supply chain and how this affects the robustness. The second module is all about modeling the truck platooning. The truck platooning module is in reality just a small attachment to the different supply chain designs that can be "turned on and off".

When the variables are clear, parameters are known and modeling is finished, experimenting can start. Three types of experimental setups are created. First, a sensitivity analysis is done for revealing further dependencies of model output and variables. Secondly, the multiple designs are analyzed under specified load cases. These load cases are a combination of the input variables. At last a specific case study is done for the RDLF.

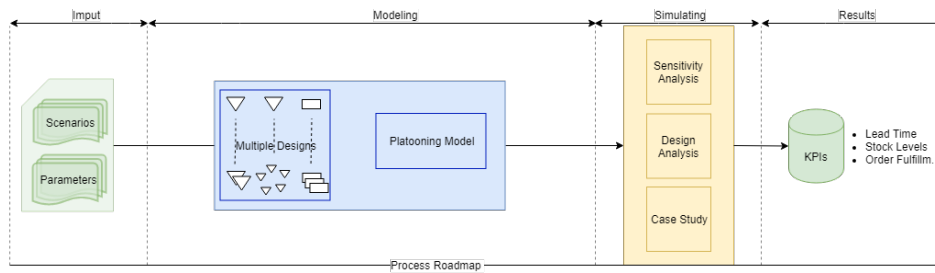

Figure 5.5: The process of modeling and simulation, showing the development needed for getting the final results. From beginning to end (left to right). Starting with a defined input set, creation of the models, followed by the simulations, resulting in KPI output.

5.3.1. Model Challenges and Language selection

The main goal of the simulation is to reveal several degrees in robustness of a supply chain. Robustness is a measure for being able to withstand sudden uncertainties in demand and supply. Testing scenarios need to be developed that simulate fluctuations and disturbances causing these uncertainties in the supply chain network. One of the major challenges is to implement these scenarios. Another major challenge is to describe all entities correctly in the object-oriented style, and have to cope with many different events without bogging down. This requires a robust coding style.

When trying to model a lifelike system, it is impossible to find one hundred percent accurate parameter values. A lot of factors influence the variables in the supply chain, like environmental factors, political, social factors. For example, consumption uncertainty cannot be represented by a deterministic value in the model, it has a certain fluctuation. Tables are present in internal documentation with numbers for intensity factors, depending on a specific situation, however, this is a rule of thumb. Not only consumption is affected by "random" fluctuations. Travel times might be influenced as well by the same influences as stated for consumption. Icy roads can have a significant influence, destruction of infrastructure or obstruction of supply routes can all affect the delivery times. When observing these situations, it creates a realization of needing a model that can incorporate and explore these crucial fluctuations. There is a need for stochastic capabilities that incorporate these fluctuations, also a repetitious model is important to compare several outcomes and provide reproducibility.

A model has to be created that resembles the entities and processes that occur in the real world case. Objects in the model need to get a certain level of intelligence that resembles the behavior of the real-world entity. Like the flow of supplies through the model needs to be correctly coordinated. The model needs to allocate the correct trucks and send them to the right entity to pick up the correct amount and types of material. Subsequently, that same truck has to drive to the unit and deliver the materials. While on route events can happen that disturb transportation, the truck needs to cope with these disturbances.

The model demands a real-time, highly dynamic environment. As can be noticed, modeling becomes quite complex it is obvious that a computer model is a good solution. A discrete event modeling architecture, using object-oriented programming, is the best tool that is available to capture the whole system. Since there is no existing model that incorporates the demands state above, a model needs to be created. The model has some very specific criteria, therefore it is pleasant to have an easy programming language with lots of flexibility. Several open-source languages are available. Python 3.7 suffices in those needs and due to the experience of the author, python is chosen. A fairly easy to understand and language, offering lots of packages and functionalities that can be implemented easily. There are several different discrete event modeling packages, however again due to experience, a package called 'Salabim' is chosen. The package comprises discrete event simulation, queue handling, resources, statistical sampling, and monitoring. On top of that real-time animation is built in [76].

5.3.2. Model Assumptions

Like in every model, this model also includes assumptions for simplifications of the model. The most important assumptions are declared and defined in this subsection.

- Interview pointed out that encounters with high demand and supply uncertainty take at most 72 hours. That is because missions or conflicts won't last longer than 72 hours due to human limitations. Therefore the model run time is set to one week (168 hours). Capturing the initial warm-up period of the model and to see the effects of uncertainty perturb throughout the model for long enough time.
- NATO documentation describes the possible deployment of a full brigade. A NATO defined brigade involves 4500 PAX, however, the state of the land forces allows to deploy up to 3 battalions of 600 PAX each, therefore this is the maximum amount of PAX that is deployed in the simulations.
- The point of disembarkation is left out of this research scope, no design differences are implemented between POD and SC during this research. The supply flow from POD is represented by supply generators in the model.
- Arrival of supplies at SC happens once a day but can be delayed by a quarter of a day. This is represented by a normal distribution with a lower bound of 24 hours and an upper-bound of 30 hours. This assumption is done since it will stress the supply chain further on a bit more. The amount of supply can vary and is delivered with a maximum of 3 DOS if requested by the SC.
- Consumption of supply is also modeled as a normal distribution. 1 DoS a day is the mean-value but can be multiplied by an intensity factor. The lower-bound is 1 DoS each day. An upper limitation of twice the mean value is maintained.
- Routing is performed in a bird's eye view, meaning straight route directly from origin to destination. However, this does not resemble a life-like situation. To compensate for the bird's eye view a factor of 1.2 is multiplied to calculate the additional transport times.
- Order handling will be done according to a first in-first out system. This is the fairest deal, units ordering first, need the resupply the most. However, there is a module implemented sorting orders by supply types, if one order is too big to deal with it will be skipped after one hour waiting time. This is to prevent lockdowns in the order process.
- The order generator is designed to fit the volume of one order exactly at one truck. This simplifies the order handling a lot and probably resembles the real-world situation, where no half-filled trucks are sent to a unit, but always will be loaded to maximum capacity.
- convoys are created according to a minimum and maximum amount of trucks, this is needed to test the effects of truck platooning.
- The entities in the model with a buffer (SC, FSC, and BG), initially start with a full stock, this reduces the warm-up time of the model. If an FSC is disabled, due to node drop-out, the buildup process starts, and stock levels are filled gradually by orders since this is a consequence of node drop-out.
- Link and node drop frequency are hard to predict, therefore after interviewing SMEs, it is decided to perform a sensitivity analysis to see when drop out rate is affecting the KPIs.
- Trucks always try to drive back to their origin location, unless told not to. Meaning that after fulfilling the order the truck returns to the location where the pickup of supplies happened.
- Units are only allowed to reorder if:

1. The previous orders are delivered and still more DOS is needed.
 2. It took longer than 24 hours to deliver and still more DOS is needed.
- For networked FSCs it is allowed to try to refill their stock by invoking other FSCs, however, it is only allowed to move supply forwards in the chain, this is most logic and prevents the model from infinite loping supplies in between FSC.
 - FSCs are allowed to move at a maximum speed equal to the advancing unit that the FSC is assigned to. If the units are stationary, the mobile FSC still have unit standard speed to fulfill the demand of the notice to move time.
 - Communication delays or information stream times are ignored in this model. Only physical delays are modeled, like transfer times, node- and link-recover times, convoy forming times, etc.
 - when order failure might happen in terms of order incompleteness or large delay, the order will still be delivered. A failed order is an order taking longer than 12 hours to arrive after the unit requested the order. The generic model claims 24 hours is the allowed time, but in reality, orders sometimes need to be delivered much faster. SMEs claim 4 hours can be possible demand. It is chosen to meet somewhat halfway at 12 hours of delivery time.
 - Node drop-outs occur only at FSC level. Units are immune to drop-outs because the cause of the model is to stress the supply chain. Unit drop-outs will relieve the supply chain, due to lower consumption rate. When a link drop out occurs, all vehicles that have orders to travel along that link, are canceled as well as their orders, the order flow directly back into the order-pool and will be picked up as soon as possible.

The most rigorous assumptions are displayed above, with an explanation of why these are made. Behind almost every assumption a reason is presented that will try to make sure the supply chain is stressed at its max. Also, assumptions are made because of a modeling point of view; to reduce model complexity or eliminate unnecessary modeling time.

5.4. Conclusion

This chapter breaks down the supply chain into smaller understandable chunks of present entities and interaction processes. The essentials of a supply chain are buffers and transportation. Buffers represent certain supply and demand nodes in the supply chain of the Royal Dutch Land Forces. The first buffer represents the supply center, followed up by an optional forward supply center buffer. If the concept design of the RDLF supply chain a networked configuration is involved, using multitude of FSC. The third buffer in the model represents the individual units of the BG. In between the buffer zones, transport routes, called links, are found. Trucks move along the transportation links to transport supply. Supply gets to move forward, information flows backward in the supply chain. Trucks are considered a circular internal flow of resources in the model.

Furthermore, a process figure is created. This process shows the methodology of the modeling and simulation that will eventually result in useful output, bringing us one step closer to closing the research gap and answering the main research question.

At last, several important assumptions are shown, these assumptions are needed to capture the right level of detail, without overdoing. Also the assumption help in reducing simulation times and computing power needed.

The findings of this chapter:

- SC, FSC and units are the most important entities in the supply chain.
- The supply flows in between entities is performed by trucks, information flows are the orders. Trucks are the connection between supply and information flows.

- Node- and link drop-outs are representing delivery/supply uncertainty, while consumption rate represents demand uncertainty, these are the variables in the model of the supply chain.
- Suited modeling language is Python, a discrete event package called 'Salabim' will be used to create an object-oriented computer model. 'Salabim' contains extensive simulation functions. The simulations can be run in real-time.
- Due to trying to simulate a real-world problem, many stochastic functions are involved.

Sub-Question 4:

How to design a supply chain for military operations?

Answer:

- For designing a supply chain a computer model is going to be developed. An object-oriented programming language is the best method to convert the supply chain into a computer model. Python is chosen as language and a discrete event modeling and simulation package named "Salabim" is used as well. According to the Delft Systems Approach, two types of flows should be modeled, a supply flow and an information flow. These flows perturb through the system in between entities. Trucks are a flow of resources in the system that connect order and supply and enable the transportation function of the model.

6

The Simulation Model

6.1. Introduction

This chapter builds further upon the findings of the previous chapter. In the former chapter, a general methodology and framework were presented. In this chapter modeling structure and experimentation choices are elaborated in more detail. This is for ease of reproducing and understanding the model. The goal of this chapter is to think the model through and examine all that is involved before experimentation. Topics as; key performance indicators, detailed process flows, sample sizes, model structures, variables and validation, and verification are discussed in this chapter.

6.2. Model Performance and Robustness Objectives

KPIs need to be monitored in order to measure the output of the model and consequently compare the results of different scenarios. When comparing the KPIs one can distinguish several model designs that might be preferable for the SC. In table 6.1 an overview of KPIs is presented including an explanation

Table 6.1: Table of overview of key performance indicators

<i>KPI</i>	<i>Description</i>	<i>Quantity & Unit</i>
Stock level	The stock levels of all objects in the SC tell us how well the chain performs, depleted stocks mean an unsuccessful supply chain and are not desirable.	Amount [DOS]
Order fulfillment	Order fulfillment is a great indicator for checking if orders arrive in full and in time at the right unit. Stock levels might be sufficient, but if order fulfillment is low, the supply chain doesn't perform optimally.	Fraction [%]
Lead times	Observes the time it takes to get from the beginning to end through the cycle. Very short throughput often indicates a well-performing supply chain, however, it might point out that the supply levels are constantly too low, therefore a too short throughput might be not desirable. Shorter lead times result in a more responsive supply chain	Time [h]

During the simulation mean values will be used for further analytic endeavors. However, all stock levels are being monitored in real-time and are observable, when the run is done extreme values are printed as well by use of boxplots. Keeping an eye on extreme values will tell us something about the variance of the runs, those are also important when trying to realize a robust supply chain, so an expression can be formulated that can guarantee a certain level of robustness. For example: when average stock levels occur reasonably, but

supply levels vary a lot, units are multiple times exposed to a drastically low amount of supply. When judging the mean values good robustness would be observed, however, when looking at variance it would result in a low robustness observation. The same is to be said for order fulfillment and lead times.

Keeping an eye out for extremes and monitoring the averages of the KPIs is important, but how to express the results in robustness. As can be read in the literature, many agree over the concept of robustness, however, one unified definition does not exist yet, let alone a unified way to measure robustness. In the end, robustness is supply chain specific and depends on the goals per supply chain. In this report, robustness is assessed by comparing different designs.

The way robustness of a military supply chain is proven is by comparing the multiple configurations of the concept supply chains versus the current linear supply chain in a case study. The case study analyzes ten model design configurations and selects a scenario by analyzing a specific area of interest in Europe. Robustness cannot be defined according to one value, in this research robustness will be expressed as the average relative improvement of all three kpis per model configuration. Relative improvement will be expressed in percentages between model design configurations.

6.3. Supply Optimization and "Notice to Move" Models

In this research two sub-modules are added.

- Integer order optimization
- Swarming behaviour for FSCs

These are considered necessary and interesting to implement since the integer-order optimization assures an optimal order creation in the supply chain model. Swarming behavior of FSC deals with a criterion demanded by the DoD that is called "Notice to move". Notice to move means that the FSCs need to relocate every 3 hours while leaving the networked configuration intact. A good way to implement highly dynamic FSCs is what is known as swarming algorithms. This ensures a networked configuration while also simulation a more natural way of behavior.

6.3.1. Supply Optimization model

As soon as units are demanding supplies, it is the task of the order creator to bundle those demands and form optimal orders. This is especially a challenge when multiple demands are present of multiple units at once. Orders sizes are optimized to fit at one truck. Order sizes are therefore limited by the truck's volume and weight carrying capacities. During the creation of orders, it is especially important to resupply the units, that need the supplies most. Therefore an integer optimization keeps track of the supply levels of each unit and creates orders according to the unit and supply type that is needed most. For this optimization, a Python Pulp package is used. This uses CPLEX integer optimization. The optimization can be considered as the knapsack-problem, except that the knapsack problem is a binary optimization technique. In this research, we need an integer optimization that can assign a multitude of supplies in one knapsack, in this case, the knapsack is the order, that needs to fit into a truck.

In general, all supplies are needed equally since the consumption is every time 1 DOS a day, however, due to fluctuations in consumption and travel time fluctuation, it might be a certain type of supply that is needed more. There is a linear inverse correlation between the current supply level at units and the priority a supply should be getting when forming orders. Working with discrete supplies in our model results in a limitation to an integer optimization.

This is how integer programming is implemented:

Let us define our variables first: Maximization of the objective function is defined per order. Where x is the item, r is the revenue per item x . The summation of all types of supply in order times the revenue per item.

The maximization problem is subjected to

$$\begin{aligned} \text{ObjectiveMAX} \quad & \sum_{i=1}^n x_i * r_i \\ \text{Subject to} \quad & \sum x_i \leq O_i \\ & \sum_{i=1}^n x_i * V_i \leq C_v \\ & \sum_{i=1}^n x_i * W_i \leq C_m \\ & x_i \geq 0 \\ & r_i = \frac{1}{L_i} \\ & x_i \in \mathbb{Z} \cap r_i \in \mathbb{R} \end{aligned}$$

The needed parameters for the objective function and constraints are declared below, also the indices are indicated.

O = Maximum order quantity

C = Truck Capacity

r = Revenue

L = Stock length

i=1,...,n Types of supply max 5

v volume

m mass

6.3.2. Distance-based Swarming for Forward Supply Centres

For the simulation of highly mobile movement of the FSC a swarming algorithm is chosen. According to publications of the DoD at least every 3 hours a relocation needs to take place. In the simulation, the FSC relocated every hour across several kilometers, typically about five kilometers. Swarming is a good way to resemble the situation since the FSC are not allowed to get too close, however, they do need to stay interconnected between a certain distance, depending on the situation. Due to communication, the FSCs will continuously try to mitigate an optimal location.

However, their movement is free within certain distance limits in between, the center of mass should lay somewhere around the midpoint between SC and unit.

In literature three relative simple laws have been formulated to simulate the behavior of a swarm. The laws of Reynolds [63]. Three laws dictate three forces enacting upon a FSC. These are separation, cohesion, and alignment.

The input for the control of a swarm is given as:

$$\vec{u} = F_{sep} + F_{ali} + F_{Coh} \quad (6.1)$$

The first law of separation forces is defined by

$$\vec{F}_{sep} = c_1 * \sum_j \frac{1}{l_{i,j}} \quad (6.2)$$

the second law is concerns alignment, meaning that the individual in the flock needs to adjust the same steering angle as the average of the group. This is modeled as a force that steers the angle towards the correct "direction".

$$\vec{F}_{ali} = c_2 * (d_i - \frac{\sum_j^n d_j}{N}) \quad (6.3)$$

the third law is about cohesion, the individual needs to be stick with the swarm. The force that simulates this is described as follows

$$\vec{F}_{coh} = c_3 * \sum_j \vec{l}_{i,j} \quad (6.4)$$

For this model a 4th force has been introduced. This is done due to the need of following one specific unit. For our simulations it is important that the networked FSCs do not move around randomly, but stay clustered around a specific point at 90 kilometer before the unit and between the unit and SC. The is called, the following force F_{fol} .

$$\vec{F}_{fol} = c_4 * \vec{l}_{i,pointfollow} \quad (6.5)$$

No masses of FSCs are included in the simulation model, therefore a direct relationship between input and accelerations that controls the swarm is created:

$$\vec{u} = \frac{\vec{F}}{m} = \vec{a} \quad (6.6)$$

$$\vec{l}_{i,j} = p_j - p_i \quad \text{length between i and j}$$

$$\vec{d}_i \quad \text{direction of i}$$

6.4. Classes

As described in chapter 5, discrete event modeling is the most suited for this study due to its natural way of modeling with objects. These objects can be given a certain intelligence, which results in independent agents that can work in a modular way. In a DEM environment, an agent is an instance of a class. The classes determine the overall behavior of the agents, like a blueprint. Agents of one class, have the same functions, states, and processes inherited by that class. No robust supply chain research can be performed, if there is no robust simulation model, therefor functions and flows between agents need to be clear. One of the biggest advantages of DEM is the protected way of programming within a class, chances within a class do not directly affect the whole system, as long as the communication links in between the agents are kept intact. A table is presented 6.2 that describes all classes present in the model. The classes are briefly explained, functionalities are given and the needed physical information about the class.

Class	Description	Functionalities	Characteristics
Supply Centre	The first entity to encounter in operational areas, a SC stores all incoming supply from the point of disembarkation. Supply arrives according to a Gaussian distribution with a mean around 1 day.	Storage of supplies	Location Capacity Order queue Truck queue
Forward Supply Centre	An optional, smaller, storage location. Deployed to ensure a better flow of supplies. If needed an FSC receives supply from the SC. In the new model, FSCs are mobile and operate networked.	Storage of supplies, Movement, Formation control	Location Capacity Direction Velocity Order queue Truck queue

Class	Description	Functionalities	Characteristics
Unit	A demand node in the supply chain consumes supply, that is delivered by SC or FSC. Consumption is dependent per situation and is represented as a Gaussian distribution function, can move and request supply if needed.	Storage of supplies Movement Consumption of supplies	Location Capacity Direction Velocity
Truck	A Mean of transportation between SC, FSC, and Unit, that is concerned with the displacement of supplies. Needs to be able to claim an order and fulfill it.	Storage of supplies Movement	Location Capacity Direction Velocity Order queue
Supply	Supply appears in 5 different types. Supplies are transported from SC to ultimately the units. Supplies are always in stock if not, they are consumed by the unit. If supplies are transported, they are linked to an order	None	Type Volume Weight
Order	Orders contain information about the requested supplies; the quantity, quality (the kind of supplies), the customer and destination are included. Orders can be transferred between supply nodes and trucks.	Information container	Destination Origin Type of supply Amount of supply
Supply generator	Supply generators are agents that produce the supplies at a certain interval. The interval time is equal to a Gaussian distribution with a mean of one day. Supply generators can generate each type of supply, and are "nested" in an SC.	Generation of supplies	None
FSC generator	If desired, FSCs can be generated automatically. When a distance threshold is exceeded between SC and unit an FSC is created.	Generation FSCs	None
Truck generator	Generates the desired amount of trucks. This can be predefined, locating trucks at SCs and FSC or can be generated at the moment they are needed.	Generation of trucks	None
Order generator	The order generator forms orders according to requested supplies by units. The order generator contains an optimization process, that ensures an optimal truck usage.	Generation of orders	None
Order checker	The order generated by the order generator are pushed through to the order checker. Here a decision is made for the order about what supply node has the available amount of supplies.	Check order destinations	None

Class	Description	Functionalities	Characteristics
Truck selector	After the order has gotten a destination to retrieve the supplies from, the most nearby truck is selected that is available. If no trucks available the order is kept on hold.	Check truck availability	None
Convoy checker	Trucks are not allowed to pick up the order and drive, convoys must be created to resemble reality. The minimum amount of trucks needed to form a convoy is variable and adjustable to the programmers' liking.	Formation of Convoys	Truck queue
Dropout	The drop-out agent created drop out events based on random selection and assigned inter-arrival time.	Node and link drop-out	None

Table 6.2: Table of agents implemented in the model, including description, functionalities, and physical characteristics

6.5. Processes and Flows

This section tries to clarify all processes and flows of different agents, as defined in the classes. As was summarized in table 6.2 about 14 different classes are present managing the model. Three visualizations of the different flows are presented and one overall visualization including all classes

In general, 3 types of flows are present in the model.

- Information flow
- Supply flow
- Truck flow

6.5.1. Information Flow

The information flow is the top layer in the model, as it is involved in every asset or class in the model. The information flow occurs as orders. In figure 6.1 the information flow is visualized as is perpetuates thought the model.

Information flow goes backward in the supply chain, as opposed to the supply and truck flow. The information flow starts at the units. Units create demand in supply. This demand is sent to the order generator. Here all demands from all units are combined into complete orders, orders are designed to fit one truck exactly, for easy implementation in the model, in real life this is not the case. From the order generator, the order flows further down the information stream into the order checker, where it is waiting to be checked for supply nodes to get the supplies from. The order is placed in a virtual queue at that truck selector. Here the closest passive truck is located. If no trucks available, time simply elapses until one is available. When the order is attached to a truck, the convoy checker checks if there is a minimum amount of trucks going to the same destination. If a minimum threshold is surpassed of minimum order, and thus trucks, the trucks are released.

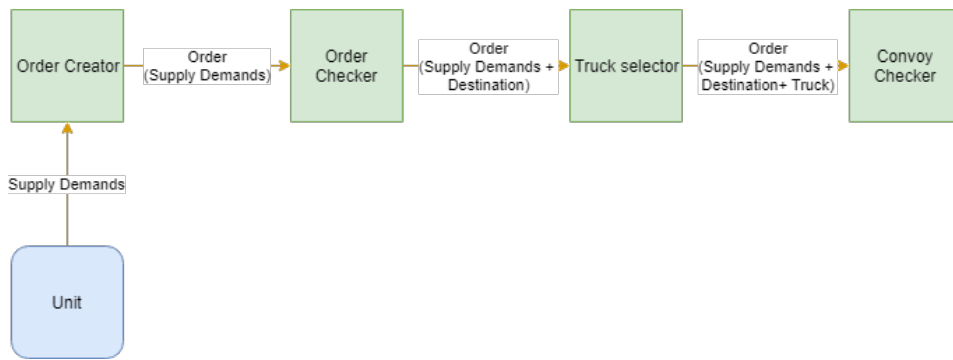

Figure 6.1: The flow chart of information in the supply chain

6.5.2. Supply Flow

Supply is generated by a supply generator, and is part of the SC, however for convenience is drawn before the SC. As soon as the supply is generated, supply is stored at the SC stocks. It stays there until an order picks the supply and stores it at a truck. From here supply can go or directly to the unit, or an FSC. When going to an FSC, it is stored at the stocks of the FSC. When going directly to a unit, supply is consumed after a certain amount of time. That is all involved with supply flows. In contrary to the information flow, supply is only allowed to flow forward in the supply chain. However supply doesn't have much functionality, it is the core element that determines the robustness in our system. All KPIs are deducted from supplies in one way or another. Figure 6.2 visualizes the flow of supplies.

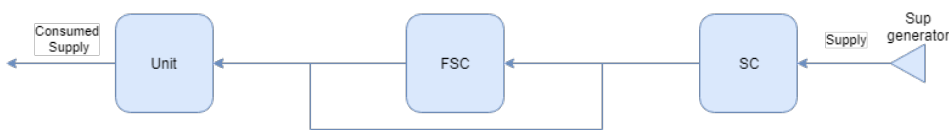

Figure 6.2: The flow chart of supplies in the supply chain

6.5.3. Truck Flow

All trucks the trucks do is the pickup of supply and delivery to a certain demand node. Trucks flow up and down the supply chain in a circular behavior. Truck flows don't start or end since they stay in the supply chain. The only exception for a truck to leave the flow is when it is removed from the supply chain due to node- or link drops. Trucks start loading supply from a supply node and travel in convoys to a customer node where the unloading happens. Figure 6.3 shows the circular flow of trucks.

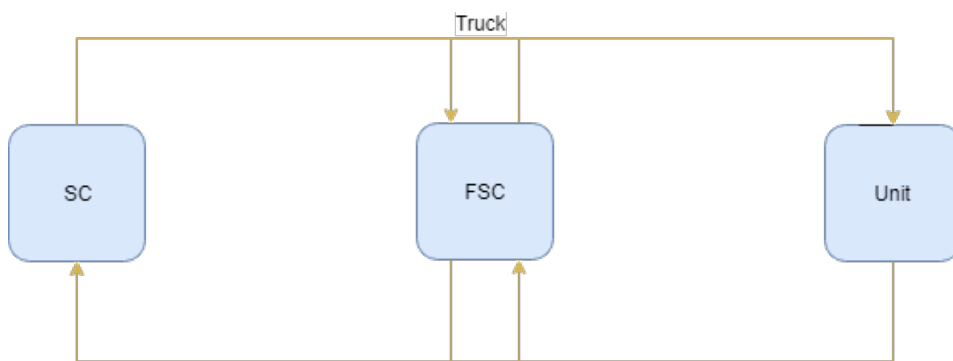

Figure 6.3: The flow chart of truck movement in the supply chain, the circularity can be seen clearly

6.5.4. Flows combined

The total flow and dependencies are displayed in figure 6.4. Here the different flows are combined into one figure so an easy understanding of the system is possible.

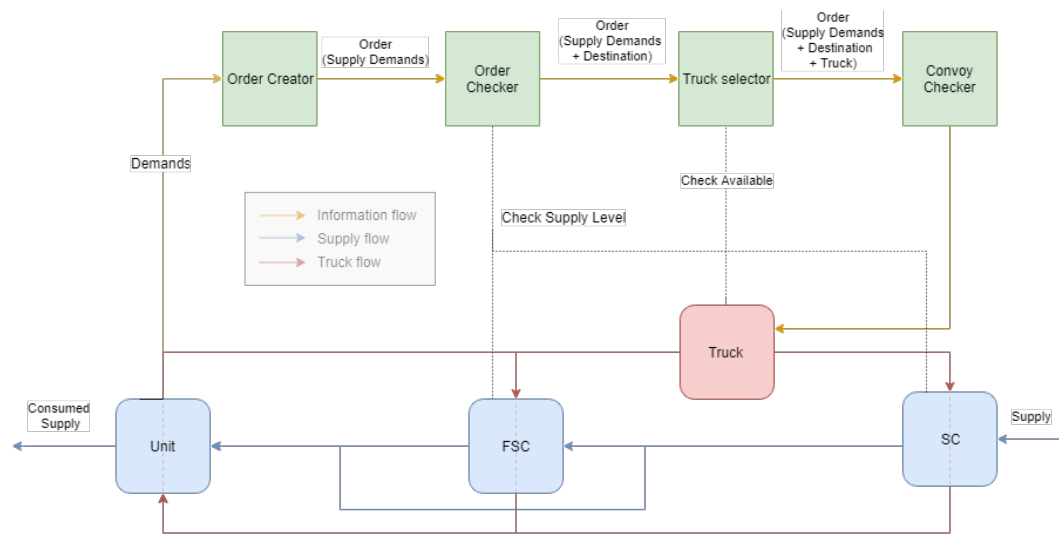

Figure 6.4: The combination of all 3 separate flows are displayed here in one complete overview.

6.6. Model Variables

While experimenting, variables are constantly adjusted to see the effect of those variables at the KPIs that are selected in this research. Two categories of variables in this research are introduced:

- Design configurations
- Scenario Configurations

Design configurations are all about the different possible setups that can be investigated. This could be an infinite amount of different set-ups, however, the different amount of set-ups are reduced according to truthful dimensions. A second way of varying the supply chain design is the introduction of truck platooning. This is an on/off configuration.

Scenario configurations know three different variables. A scenario is defined as an environmental set-up in which the design configurations have to function. The three variables involved are:

- Consumption rates
- Link drop-out rates
- Node drop-out rates

For consumption rates, link and node drop-out rates truthful dimensions are chosen, so the research can be confined to a more doable size in experiments, in figure 6.5, a visualized overview of the variables is given for clarity.

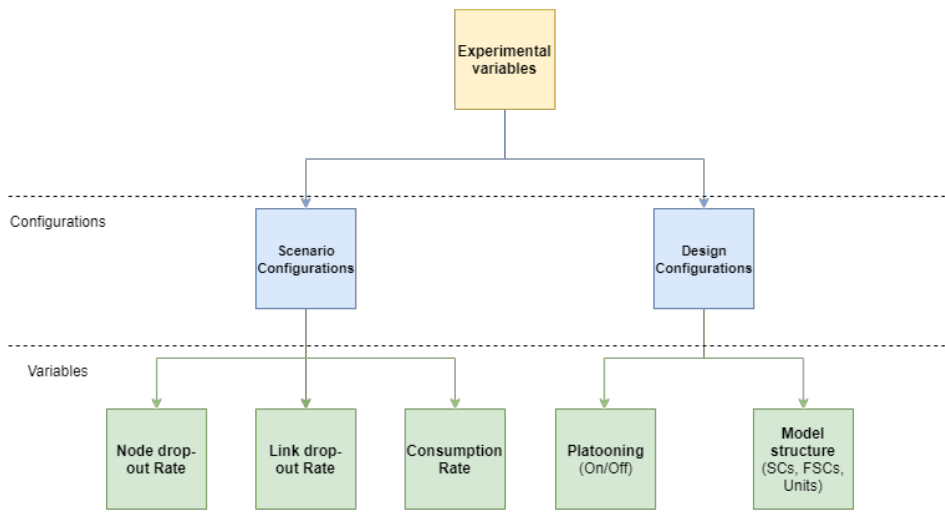

Figure 6.5: Image of a representation of all possible variables during experiments in this research.

6.6.1. Design Configurations

Design configuration concerns the layout or structure of the supply chain itself, thus called the design. It dictates the number of supply nodes and demand nodes and the links between those nodes. As discussed in chapter 3, this research focuses on a 3 echelon, multiple tiers supply chain. Better known as a supplier, retailer, and customer lay-out.

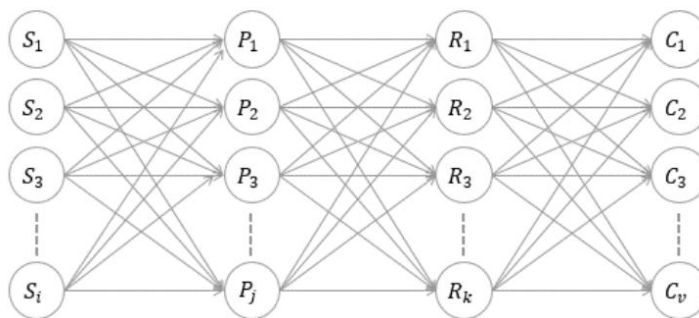

Figure 6.6: A generic model of a 4 echelon multiple tier supply system [43].

During experimenting with supply chain designs, the following applies for the maximum number of supply and demand nodes :

- up to 1 SC
- Up to 5 FSCs
- Up to 3 Units

Resulting in $1 * 5 * 3 = 15$ different design configurations. The lightest configuration is a 3 echelon, single tier configuration as displayed in figure 6.7a, the heaviest configuration is a 3 echelon 1 SC, 5 FSCs and 3 Units tiers supply chain as displayed in figure 6.7b. There are 15 different design configurations without platooning incorporated. When implementing the platooning, the total amount of design configurations is equal to $15 * 2 = 30$.

The simplest model is the as-is configuration that the RDLF already uses. The influence of platooning needs to be incorporated as well, when trying to relate platooning to effects in the supply chain and robustness. This means that all model configurations can be equipped with platooning,

From here on the different design structure are referred to as a:

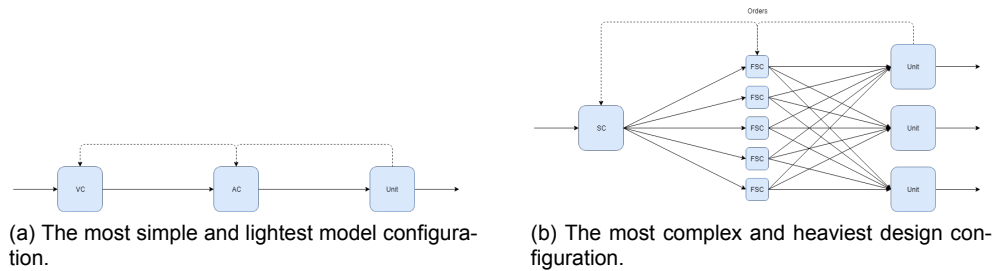

Figure 6.7: A comparison between the simplest and most complex design configuration. The simplest exists out of 3 echelons, single tiers configuration. the most complex has 2 SCs, 5 FSCs and 2 Units.

$$n_{sc} - n_{fsc} - n_{unit} - design \quad \text{where :}$$

$$n_{sc} = \text{amount of SCs}$$

$$n_{fsc} = \text{amount of FSCs}$$

$$n_{unit} = \text{amount of Units}$$

for clarity, a 1-1-1-design refers to a single SC, single FSC, and single Unit design structure, while a 1-5-2-design refers to a single SC, 5 FSCs and 2 units design.

The model configuration research emphasizes the research for networked operating FSCs. Research has not been conducted so far on experimenting with a 3 echelons multiple tier formation with a highly dynamic multi-agent simulation that enables tracking of material and orders throughout the whole supply chain while enduring several scenarios that might jeopardize the robustness of the supply chain.

6.6.2. Scenario Configurations

Besides investigating multiple design configurations, scenarios can be varied as well. Scenarios are the "virtual environments" under which the model designs have to operate. This research looks into 3 different variables that together form a specific scenario configuration. The different scenarios try to emulate the actual real-life situations in which the dutch land forces might be operating in. Besides investigating applications within a military context, these scenarios can be extracted to commercial industries as well. The parameters of the experiments can be adjusted to different values matching commercial environments, more on that in the discussion.

6.6.3. Fluctuation of Demand

A topic often discussed in literature concerning supply chains is uncertainty in demand and supply. Estimates of numbers for fluctuations are available. These estimates are called intensity factors. The actual consumption fluctuates heavily depending on the situation and is dependent on the type of deployed unit, the type of mission, kind of warfare and environmental conditions. Environmental conditions are overall more predictable when preparing the missions, and can thus be incorporated in the calculations of a DoS. During experiments, an hourly sample will be generated to determine the consumption intensity factor. This factor is multiplied by the standard consumption rate.

Table 6.3 shows the typical numbers given. Here a selection is made.

6.6.4. Link Drop-out

As second scenario configuration link drop-outs are simulated. Link drop-outs involve blockage of supply routes for a certain amount of time. When a link is blocked, all trucks located at that specific link are removed and orders recycled. The link drop-out is a method to test supply uncertainty in the model.

The main reasons for link drop-out in a military context are material-breakdown and hostile activities. Link drops occur at all the supply routes that are in field, from SC to

<i>factor</i>	<i>Condition</i>	<i>Class I</i>	<i>class I water</i>	<i>Class II</i>	<i>class III</i>	<i>Class IV</i>	<i>Class V</i>
Climate	Cold(<5)	1	1.5	1	1.3	1.5	1
	Average	1	1	1	1	1	1
	Hot(>20C)	1	1.5	1	0.9	1.5	1
Mission	Combat	1	1	1	2	1	1
	PSO	1	1.2	1.2	1	2	0.1
NBC	NO	1	1	1	1	1	1
	Yes	1	1.5	1.3	1	1.1	1
Terrain	Flat	1	1	1	1	1	1
	Hilly	1	1	1	1.2	1	1
	Mountain	1	1	1	1.5	1	1
Unit Type	Combat	1	1	1	1	0.9	1

Table 6.3: Table of intensity factors used to calculate consumption rates.

unit. During military operations, trucks are used extensively and in harsh circumstances. Extreme loads occur regularly, in environments that can easily vary between -5 deg Celsius up to 30 deg Celsius. Expected is that link dropouts mainly influence order fulfillment and lead times, this perpetuates into a lower stock level.

The duration times of a link dropout can vary. When a convoy encounters a destroyed bridge or tunnel, it will easily take up to a day before a solution is created. When encountering an ambush the link dropout can be solved within a couple of hours. In this research, a link drop duration of a value of 12 hours is chosen. The link drop rate is expected to influence the robustness, only when occurring multiple times a day, therefore the research will focus more on multiple dropouts per day.

6.6.5. Node Drop-out

The third scenario configuration variable is about node drop-out. Node drops result in temporary disabling a supply node. This can be a SC or FSC. Besides disabling the node as a possible supply destination, the stocks are cleared completely of supply and trucks and orders deleted and recycled respectively. It is interesting to find out whether the supply chain can adequately react to such a drop. Especially the rebuilding time for the supply node and the effect on the supply stock levels of the units are expected to endure the consequences. The drop-out of supply nodes will be testing the supply uncertainty in the model.

The duration time of a node drop varies as well and no numbers are known. Fact is that when a node drop happens in a military context, all supplies will be gone and safety and security protocols will be in place. Resupplying a whole FSC would mean transportation of 4 DoS from SC. Transport alone could be achieved within a day if all supplies are at hand. Therefore this model applies a 24 hours recovery time for this model. Expected is that node dropouts impact is reduced in networked design configuration since networked operating reduces the risk of detection and overall impact. Node drops can only occur at FSC level. Units do not experience node drops, simply because it would alleviate the stress in the supply chain. SCs are considered for node dropouts

When operating in a networked, distributed manner, supplies are spread out, the chance of discovery is reduced and impact also reduced. Damage of hostilities can occur at supply nodes and links. A drop out of demand nodes occurs also in a real-life scenario, however, is left out in this research, because of the investigation of supply chain robustness due to multiple FSCs.

6.7. Sample Size

Given the supply chain incorporates multiple stochastic distributions, a distributed output can be expected. Since most of the distribution contributing to the model are simply normal or Gaussian distributions, the expected output values are Gaussian distributed as well.

There are many papers written about sample size determination for models having mul-

multiple stochastic distributions. Each having some advantages on their own and specified to specific expected distributions. For this simulation is chosen to pick the method of 'confidence interval bound variance', a methodology offered by Law & Kelton [42]. This method seeks a sample size in which the variability remains within some predefined proportion of the confidence interval around the mean. The goal is to reach a stable variance and mean after a certain number of runs are performed that are within the allowed confidence.

Calculate the coefficient of variation per sample set, while increasing the sample sizes σ is the standard deviation and μ the mean value.

$$c_v = \frac{\sigma}{\mu} \quad (6.7)$$

this gives a list of coefficients of variation. Next is to determine when the difference between the coefficients of samples is small enough. Small enough is often the allowed error. The n_{min} follows directly.

$$n_{min} = \operatorname{argmax}_n (\operatorname{abs}(c_v^{x,n} - c_v^{x,m})) < E \quad \forall x \quad \text{and} \quad \forall m > n \quad (6.8)$$

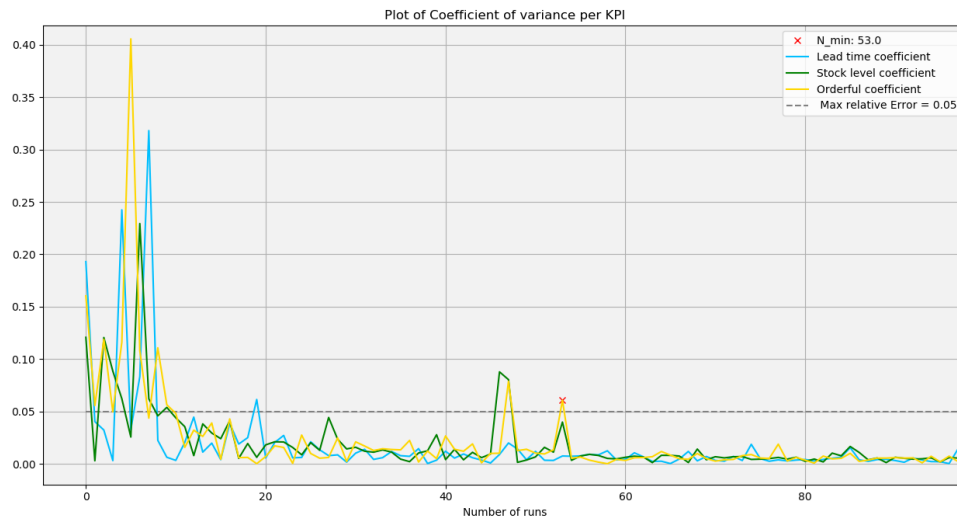

Figure 6.8: Figure of the graph to determine the sample size.

For looking at the variety in results, 300 runs are performed and the averages of each KPI per run are collected. Of all independent averages, a moving mean is calculated.

In figure 6.8 can be seen that after 53 runs no more overshoots happen to the minimum demands of a 5 % error. To be sure that enough runs are performed to do the experiments, the minimum amount of runs is multiplied by 1.5 and rounded to eventually 75 runs.

6.8. Validation and Verification

Validation is the check if the model is likely to resemble a real-life situation. The question one has got to ask: "Is the model an accurate representation of the situation? Unfortunately, there is no prescribed, fully rigid way of validating [12]. The goal of validation is to gain credibility about the model, by comparing results to a possible reference. Carson proposes several techniques to perform validation and verification, some of which will be used in this research.

Output values are examined. Are the values reasonable and do they match SME of the DoD. Output values of local processes are observed. Not only the KPI are examined, but other indicators can also be observed by monitors in real-time and give us further validation assurances. Animation implementation: Animations show the decisions that are made by

the DES, do the decisions resemble real-life situations. Idle/Active times are observed as well as totals in the systems, do the active or idle times suits possible real-life scenario's.

Verification is all about checking whether the model functions as the way it is supposed to function. This is about correctness within the model. A good way to do this is by simulation. This is the way verification has been done in this research.

During the development of the model, simulations can easily show what functions correct or incorrect. For several aspects of this research are important to keep an eye out.

- Routing: Correct routing of the simulated truck is essential. The fastest route should be picked at all times, and trucks should maintain correct speeds
- Order handling: Orders contain all the information for the model to function correctly. At all times the number of orders should be known and the orders information should be passed correctly to get the correct order fulfillment.
- Resupplying of SC, FSC and units should be monitored at all times.
- Orders in a queue and in field have to be monitored as well, to check if the correct behavior in order handling is achieved.
- FSC clusters have to be checked if the networked operated FSC are behaving correctly.
- when forming platoons it is important to check all truck platooning does meet the demands at all times.
- Dropouts of nodes and links should be observable, for the entire time a drop out is present.

Below images of the simulation are shown, indicating how validation can be achieved during experimentation. Figure 6.9a show the overall screen of the simulation, it displays the different sections. In the top left, a time control button enables us to increase the speed of the simulation. Below in red the monitors of stock levels per supply type of the SC, FSC and unit are shown, monitoring the real-time the stock levels. In green is the deployment field, this field shows the actual movement of the convoys, displays locations of all nodes in the field and has a color indicated entities to indicate supply level. In purple at the top right position, all information about the trucks is displayed including active and passive trucks. In the middle right in blue some important general information and KPIs. In the bottom right section, the order queues are displayed. Figure 6.9b are close-up of the deployment field is shown, including 2 active convoys and the list of active orders and trucks in the field. Figure 6.10a and figure 6.10b show an active link drop and node drop in the deployment field, clearly indicating what link has dropped, also a node drop can be spotted by the big cross, the black color of the FSC indicates that supply stocks are empty. Figure 6.9c shows the queue of orders in the order queues. From this order queue, orders are picked and put into the deployment field orders list. Figure 6.9d show valuable information about the trucks, including real-time total amount and passive trucks. Figure ?? displays some further information about the experiment.

Verification of the model has mainly been done by a trial and error process while keeping a close eye on the simulation screen. by trial and error an iteration of modifications in the model is performed, a quite time consuming, but necessary process. Also, validation could be achieved up to a certain level. When seeing illogical decisions during an experiment, direct actions can be taken to create a model more suited to the desired behavior that is defined by literature research, business documentation, and interview with SMEs.

6.9. Conclusion

The goal of this chapter was to elaborate on the model in more detail. Started was with clear identification and justification of the KPIs chosen. Secondly, all classes where identified that must be present in the model to operate satisfactorily. Then three different processes and their flows in the model were described in detail. Then the variables of the model were

clearly stated, this is important to know in what direction one must go when it comes down to experimenting. Now the model is completely explained and some incentives for experimenting gained. Due to the many stochastic distributions present in our model, a minimum sample size needed to be determined in order to create statements that have some significance. At last the validation and verification process is explained a bit more in detail.

Findings:

- 5 independent variables are identified with whom can be experimented and gain some insights in robustness:
 - Model design structures
 - Platooning on/of
 - Node drop-out rates
 - Link drop-out rates
 - Consumption rates
- A sample size of at least 75 runs per experiment is necessary to eliminate statistic uncertainty.
- Although validation and verification are hard to prove, the main element in the validation and verification in this research is by observing the behavior simulated in real-time. The model has been updated and corrected by a trial and error process.

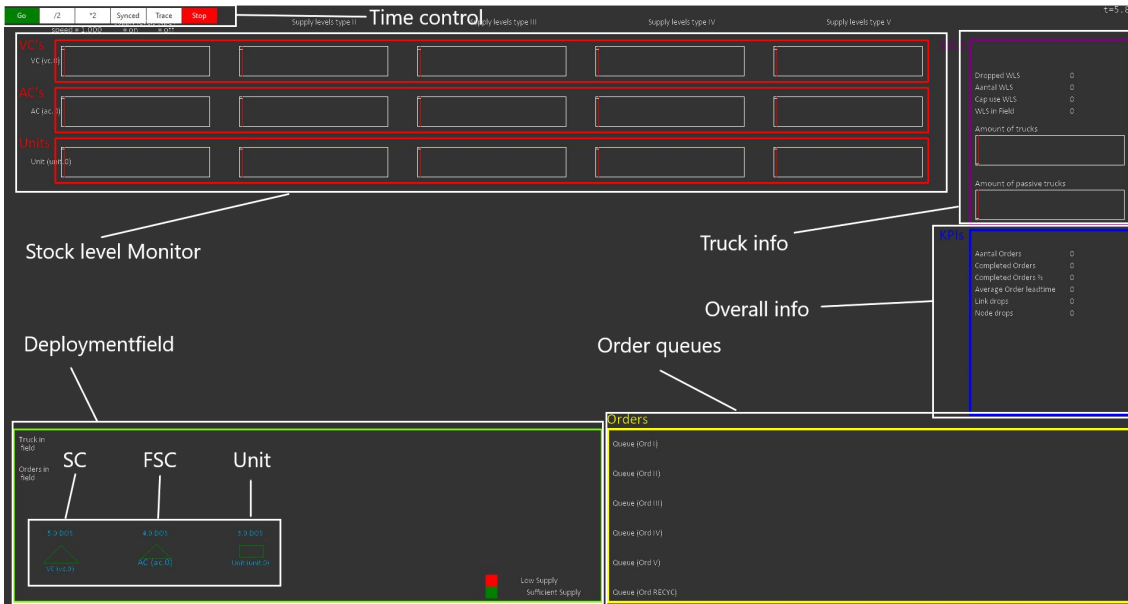

(a) General view of the simulation screen.

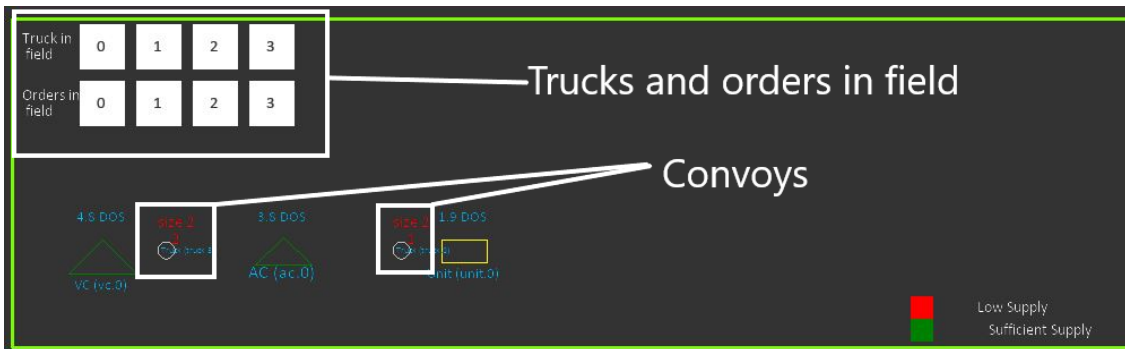

(b) view of a close up or deployment field.

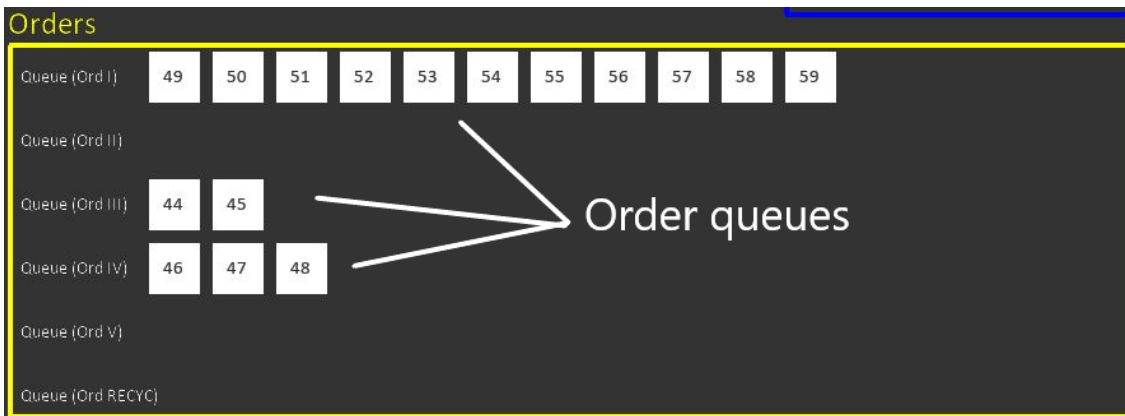

(c) View of a close up of the order queues, with several order stored.

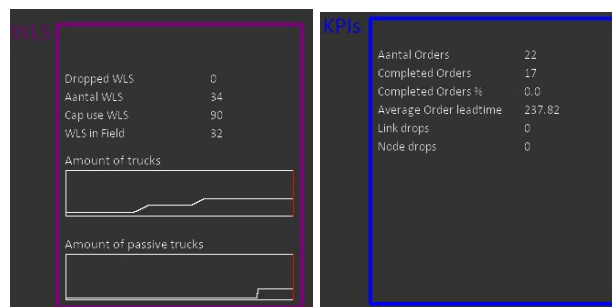

(d) View of a close up of the WLS (e) View of a close up of the overall (truck) information section.

Figure 6.9: Several images of the simulation screen, showing important events and information during an experiment.

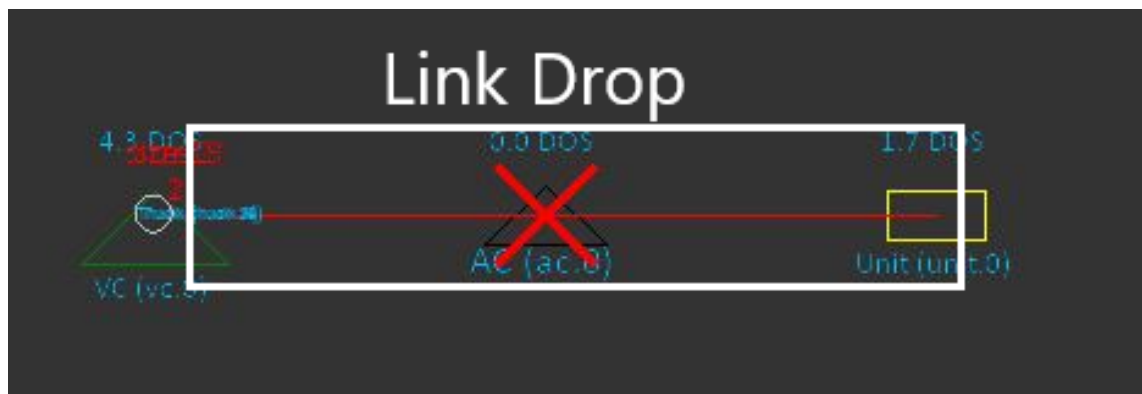

(a) View of 2 simulated link drops between unit and SC.

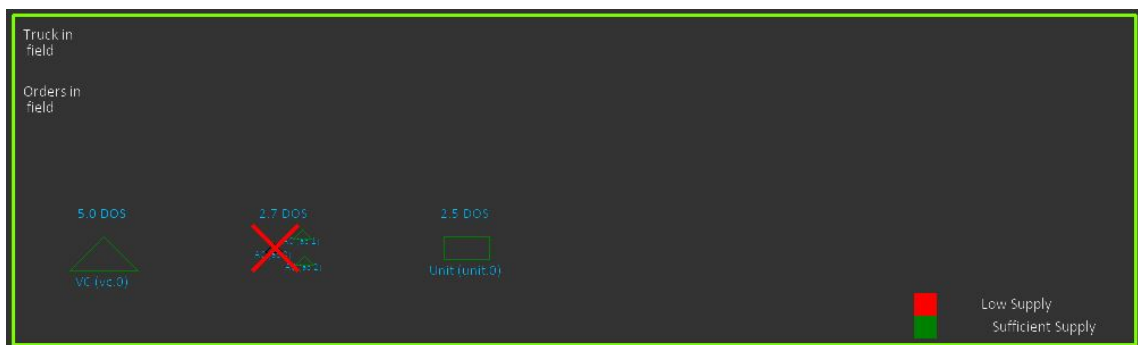

(b) View of a simulated node drops.

Figure 6.10: Two images of link and node drops

7

Numerical Experiments

7.1. Introduction

This chapter focuses on experimenting and its goals are to find relations of robustness in our model. In total three different experimental setups are presented, each having a specific goal in mind to understand robustness in supply chains that endure demand fluctuation and supply uncertainty. The chapter starts with a sensitivity analysis that tries to map out the relationship between scenario variables and KPIs. After the sensitivity analysis, an experiment is presented with three distinct load cases, testing several supply chain designs to a combination of scenarios variables. At last a case study for the RDLF is presented, trying to find the best possible supply chain design for that specific case.

7.2. Experimental Setups

This section discusses the three different experimental setups. The sensitivity analysis picks 6 different model design configurations and 15 different scenario configurations. The load-case experiment involves 3 different load packages of combined scenario configurations and 15 different model configurations. At last the case study experiment picks 10 different possible design configurations and 1 single scenario configuration, tailor-made for the RDLF.

7.2.1. Total Amount of Experiments

As written above, a wide variety of experiments are planned. This would result in the following amount of different simulations.

Sensitivity analysis:

$6 \text{ Design configs} * 15 \text{ Scenario configs} = 90 \text{ Experiments}$

Load cases:

$15 \text{ Design configs} * 3 \text{ Scenario configs} = 45 \text{ Experiments}$

Case study:

$10 \text{ Design config} * 1 \text{ Scenario configs} = 10 \text{ Experiments}$

This results in a total of 145 experimental setups. Every experimental setup has to run 75 times for significance, meaning that a total of 10.875 runs will be performed.

7.2.2. Sensitivity Analysis

To get a feeling of how the KPIs behaves as a consequence of a link drop, node drop or increased consumption fluctuations, a sensitivity analysis is created. A sensitivity analysis varies only one variable at a time, so the effects of that variable can be seen in the KPIs. For this sensitivity analysis node, link and consumption rate varied, while keeping the same model design configuration.

Besides knowing the effects of node, link and consumption rates at our model, it is interesting to see the effect when a more networked model undergoes a similar sensitivity. Decided is to pick three different model design configurations and perform sensitivity analysis at them. The three different models are shown in image 7.1. It shows the most linear 1-1-1-design, a 1-3-1-design, and the most networked model 1-5-1-design.

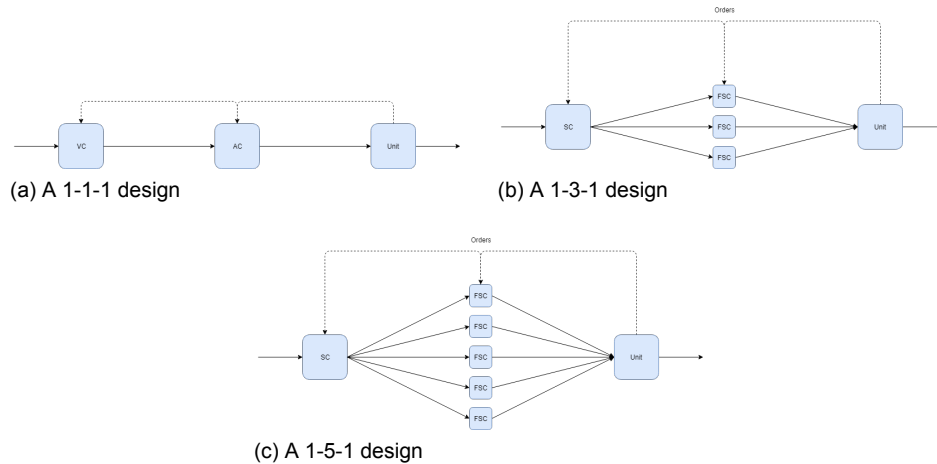

Figure 7.1: Figure of the 3 different model design configurations that endure the sensitivity analysis.

The node and link drop interval during sensitivity analysis is between once every 2 days and once every 6 hours. Smaller than an interval of 6 hours link drop would most likely mean a mission is impracticable. Consumption rates are starting with 1 DOS each day up to 3.5 DOS each day, with increments of 0.5 DOS. Besides having these three different model design configurations, platooning is tested as well. Resulting in multiplication with factor two, giving six different design configurations.

7.2.3. Load Cases

It is unfortunately not possible to test all model configurations with all different scenario configurations, due to computational and time limitations. Simulating the 15 different model design configurations and every scenario configuration (link, node and consumption rates each having 5 different rate values) will result in a total of $15 * 3 * 125 = 5,625$ individual experimental setup up, that would eventually result in $11,250 * 75 = 421,875$ runs. Still, all model configurations need to be tested, figure 7.2 shows the simplest and most complex designs that are tested. All design configurations in between are tested as well but are not shown.

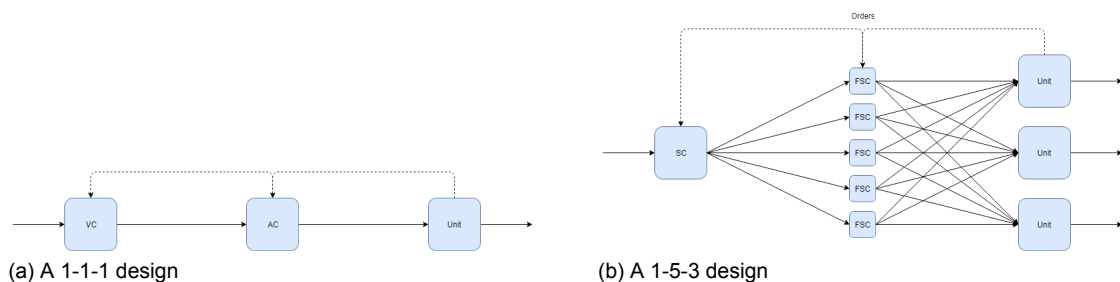

Figure 7.2: Figure of the simplest and most complex design configurations during the load case experiments. All model in between those 2 examples are also involved.

To reduce the total amount of runs, realistic packages are created of different scenario configurations. The packages let us create several "loads", based upon drop-out and consumption rates. These packages are called load cases and vary between light, medium and

heavy. This way we can explore the full range of model design configurations and see the major effects of the load cases in every KPI. The goal of this section is to make a statement about the robustness of certain designs of the supply chain, related to all possible model configurations. With the former in mind, creating packages of load cases won't influence the outcome of what supply chain is best suited.

The three different load cases are shown in table 7.1, it can be noticed that the intensity factors of Type I and Type I water are merged into one factor which is the average of both Type I intensity factors. The volumes that will be calculated within the model will thus also be an average of both volumes.

Table 7.1: Intensity factors and drop-out rates for Duty Classes

Load cases	Operational conditions				Calculated IF					
	Climate	Mission	Terrain	NBC	Type I	Type II	Type III	Type IV	Type V	Drop-outrate [h]
Light	Avr.	PSO	Flat	No	1.1	1.2	1	1.8	0.1	24
Medium	Hot	Combat	Hilly	No	1.25	1	2.16	1.35	1	12
Heavy	Cold	Combat	Mount	Yes	1.56	1.3	3.9	1.49	1	8

When calculating the different total intensity factors, the average heaviness of the load cases can be seen. A steep inclination of heaviness is observed. The IF of load case 2 is 10 times as heavy. Load case 3 is roughly 3 times as heavy. This is done on purpose, because increasing the 3rd IF by a factor 10 will result in an completely bugged down supply chain, with unrealistically high IF.

$$\text{Loadcase 1 IF} : 1.1 * 1.2 * 1 * 1.8 * 0.1 = 0.2376$$

$$\text{Loadcase 2 IF} : 1.25 * 1 * 2.16 * 1.35 * 1 = 3.645$$

$$\text{Loadcase 3 IF} : 1.56 * 1.3 * 3.9 * 1.49 * 1 = 11.785$$

7.2.4. Case Study - A military operation near Mszanka

In the previous section, three different duty classes are defined by creating a combination of variables. This in contrast to the sensitivity analysis, where just one variable was tested at a time. The types of duty classes were expressed in a low, medium and high duty. When testing the designs of the supply chains, the behavior could be seen between duty classes and different model designs.

However, these 3 duty cases don't resemble a real possible situation very well. In this section, a brief case-study is done into the most realistic scenario possible. After the scenario is explained, the most likely supply chain designs are tested with and without platooning. So we can conclude what supply chain suits best for the given scenario.

In total 5 different supply chains are tested. Starting with 1 SC, 3 deployed units and a variety of up to 5 FSCs. All an image of the minimum and maximum configurations are shown in figure 7.3. The battle group deployed is a complete brigade, build up out of 3 battalions, consisting out of 600 PAX each. For the case study, the units deployed are consisted partly mobilized Light infantry.

Besides testing 5 different designs, platooning will be implemented as well and compared to the performance without platooning. This will result in 10 different setups of the case study.

Location

The thing to decide is what location is a likely location for our study and is suited for the study. Due to changes in the political climate, a shift is made from a peace support mindset to a more combat-focused mission character. Also, the center of attention is slowly shifting to the east border of Europe, due to several events that happened recently.

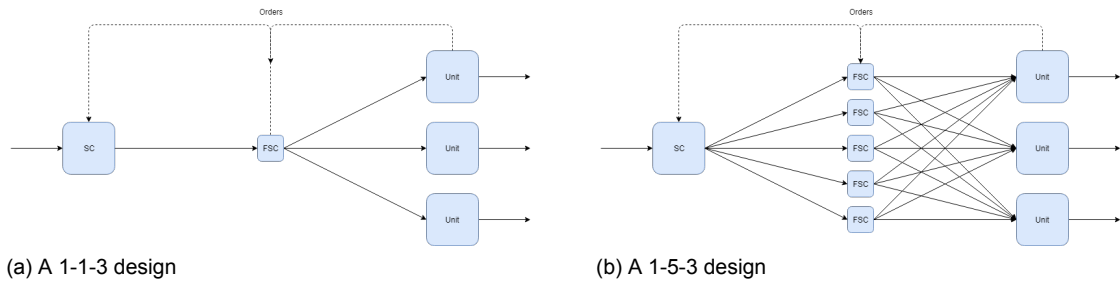

Figure 7.3: Image of a representation of the design with the minimum amount of FSCs and maximum amount of FSCs



Figure 7.4: The area of interest for this case study, concerning eastern Europe within the red rectangle.

Even the focus is shifting towards combat, the principle is still mainly defense. According to handbook staff planning data, the maximum defense width of a brigade is about 20 kilometers. This is therefore the maximum defense line width in this case study. Along this line, the height difference is observed, so the terrain is known. Possible advantages of highland are a better overview, also forested areas give better protection and are particularly of interest.

the chosen location is the area near the Polish town of Mszanka. It has a decent height, is forested and close to the eastern border.

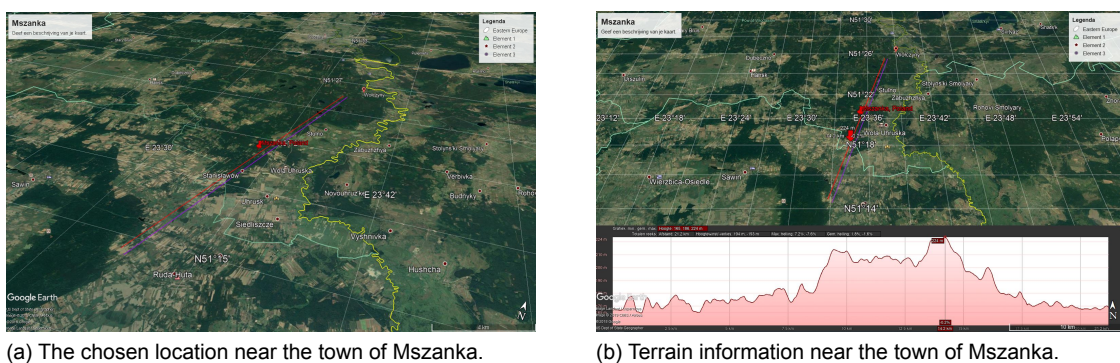

Figure 7.5: Overall information about the location chosen for this case study.

As can be seen, the height differences are quite present in this area. Up to a maximum of about 224 meters, the lowest value is about 160 meters. Terrain, therefore, gets the qualification hilly. The climate around this area is most of the year does not reach 20 degrees Celsius. During winter months a temperature of -5 degrees Celsius can be reached (source:

<https://en.climate-data.org/>). Climate conditions are considered cold. Furthermore, no nuclear, biological or chemical (NBC) warfare is expected in this area. A summary is given in table 7.2.

Factor	Conditions	Values				
		Class I	Class II	Class III	Class IV	Class V
Climate	Cold (<5 ° C)	1.25	1	1.3	1.5	1
Terrain	Hilly	1	1	1.2	1	1
Mission	Combat	1	1	2	1	1
NBC	No	1	1	1	1	1
Unit	Light Infantry(C)	1	1	1	1	1
Totals		1.25	1	3.12	1.5	1

Table 7.2: Table giving overview of intensity factors for demand fluctuations at unit level, specialized for the case study.

The next question we have to ask is how many link and/or node drop-outs will occur. When getting involved in a defensive combat scenario, logistics are an attractive target, to soften up deployed units, artillery advances of a possible adversary can easily reach a 70 kilometers [22]. According to SMEs, it is not unthinkable that around 4 link- and node drops occur every hour. This is, however, a rough assumption and hard to estimate. Nevertheless, node- and link drop frequency is put to 4 each day, in other words, every 6 hours.

7.3. Results

Results are shown here by graphs and boxplots. These graphs will give insights into the trend of the averages. The boxplots will show the medians and outliers. Even though the outliers are sometimes considered not relevant for the overall measurement, in this research outlier gives a lot of information about what percentage of runs give a certain outcome below the desired value.

Robustness cannot be determined by a single value, but has to be observed relative to each model design. The relative improvement between models is expressed as a percentage increase or decrease in KPI values. The mean value is calculated of the relative improvement per design, this will be an indicator for robustness.

The results are displayed in three subsections. The first subsection contains all results of the sensitivity analysis. The second subsection is all about model design testing under 3 different load cases. The last subsection displays the results of the case study. Table with values used for the graphs of the sensitivity analysis are added in the appendix, due to the size.

Discussion of the result will follow in chapter Findings and Insights.

7.3.1. Sensitivity Analysis

Below, the figures related to the sensitivity analysis with and without the results of implementation of truck platooning are depicted. First, a graph and boxplots 7.6 of stock levels are shown, followed by a graph and boxplots 7.7 showing order fulfillment percentages and at last a graph and boxplots 7.8 containing the lead times is given. Below each graph three small boxplots are shown per model design configuration. Each graph contains six values linked to the scenario variables. To compare each KPI correctly a baseline value is developed and is the first value of each set of the graph during all sensitivity analysis. The baseline is a value that arose by having a rate of zero link or node drops per day and a consumption rate of 1 DOS per day. The graphs contain the results of sensitivity analysis of a 1-1-1-, 1-3-1- and 1-5-1-design. Additionally in the graph the platooning results are also shown.

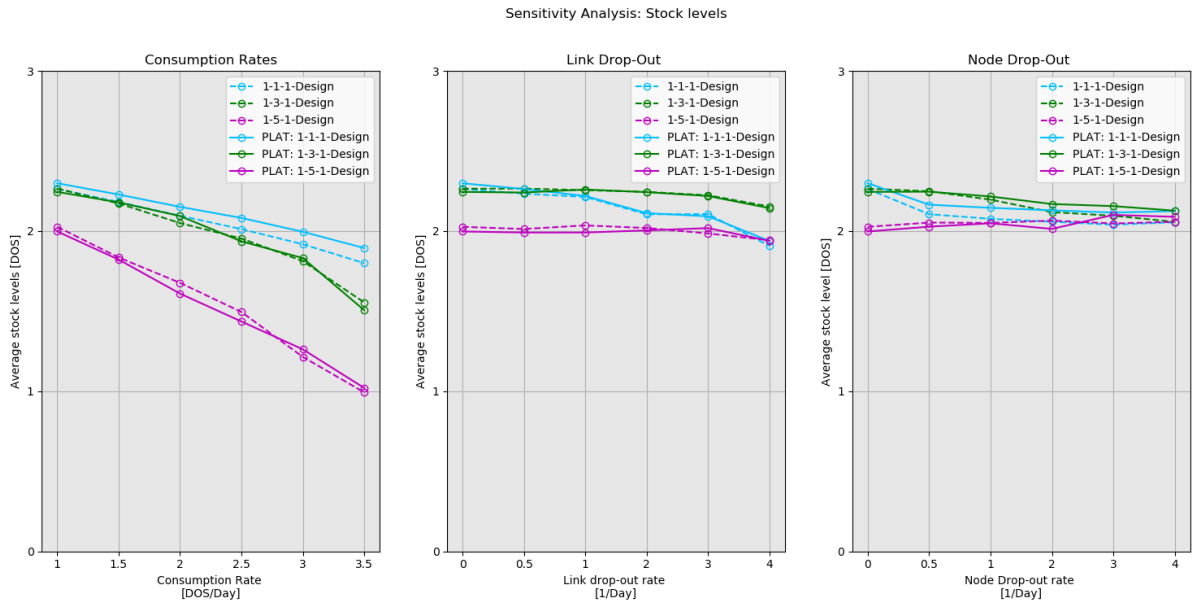

(a) A graph showing the stock level information of the sensitivity analysis. The results of implementing platooning are added.

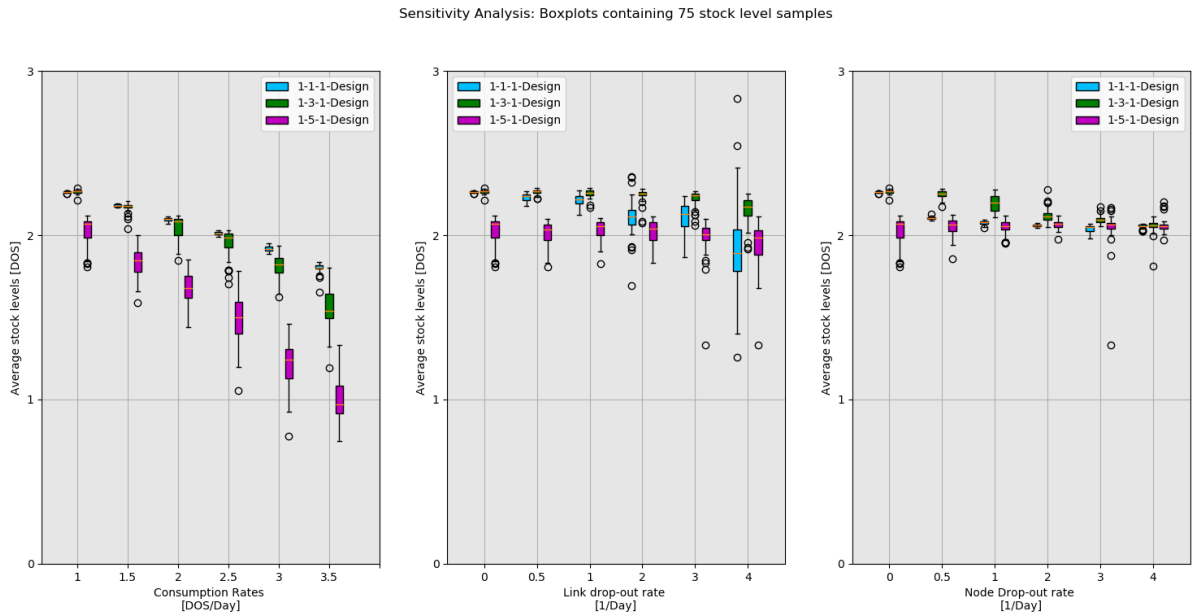

(b) A boxplot showing the stock level information of the sensitivity analysis.

Figure 7.6: Two figures containing the sensitivity analysis information about the stock levels of three different designs.

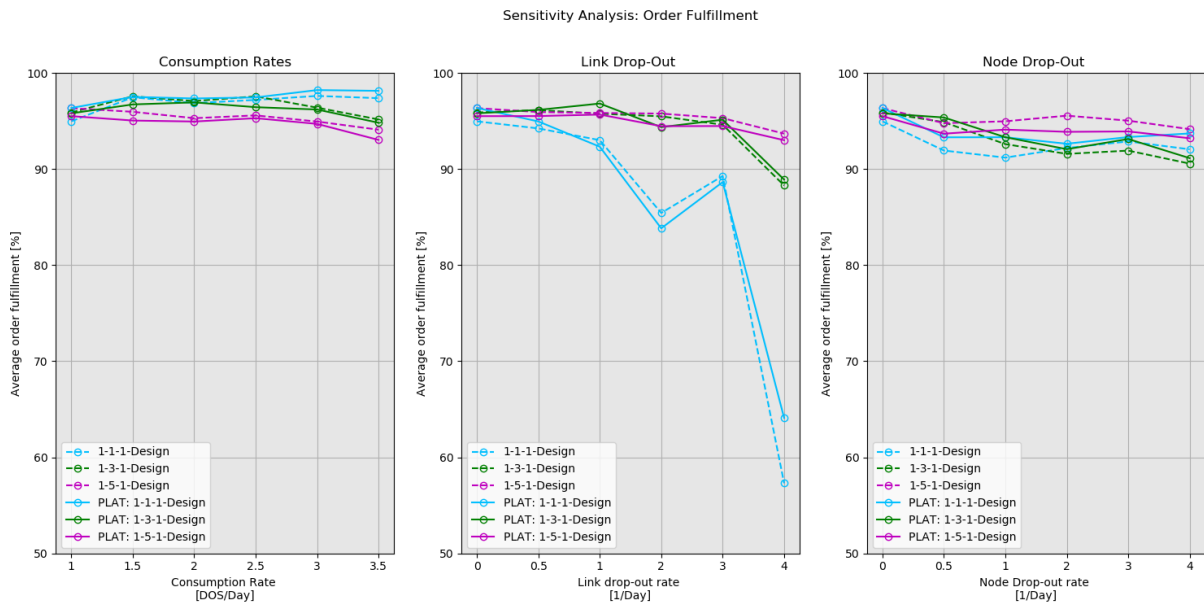

(a) A graph showing the order fulfillment information of the sensitivity analysis. The results of implementing platooning are added.

Sensitivity Analysis: Boxplots containing 75 order fulfillment samples

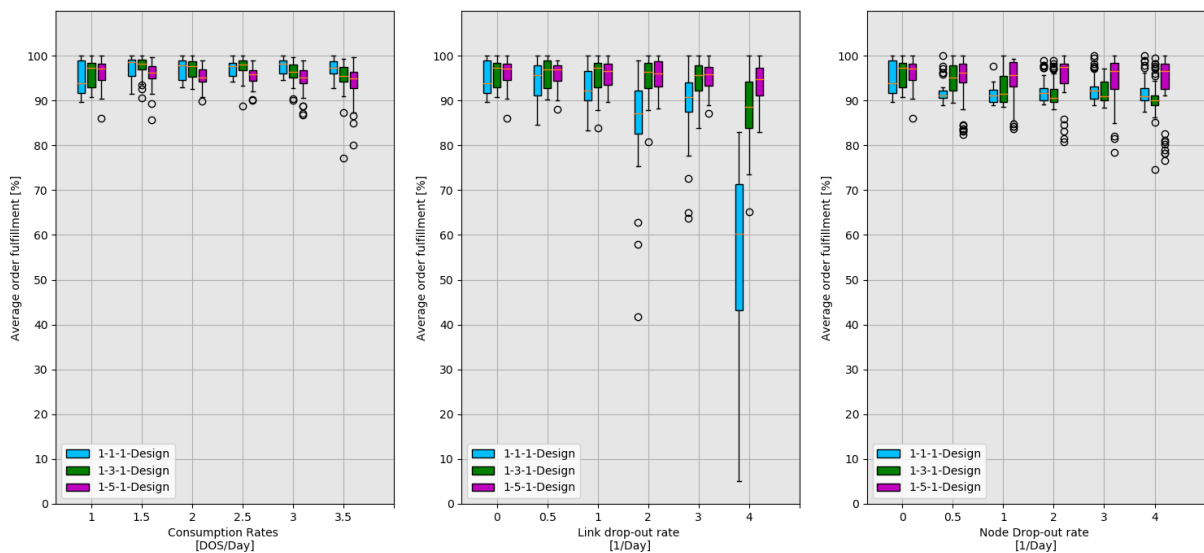

(b) A boxplot showing the order fulfillment information of the sensitivity analysis.

Figure 7.7: Two figures containing the sensitivity analysis information about the order fulfillment percentages of three different designs.

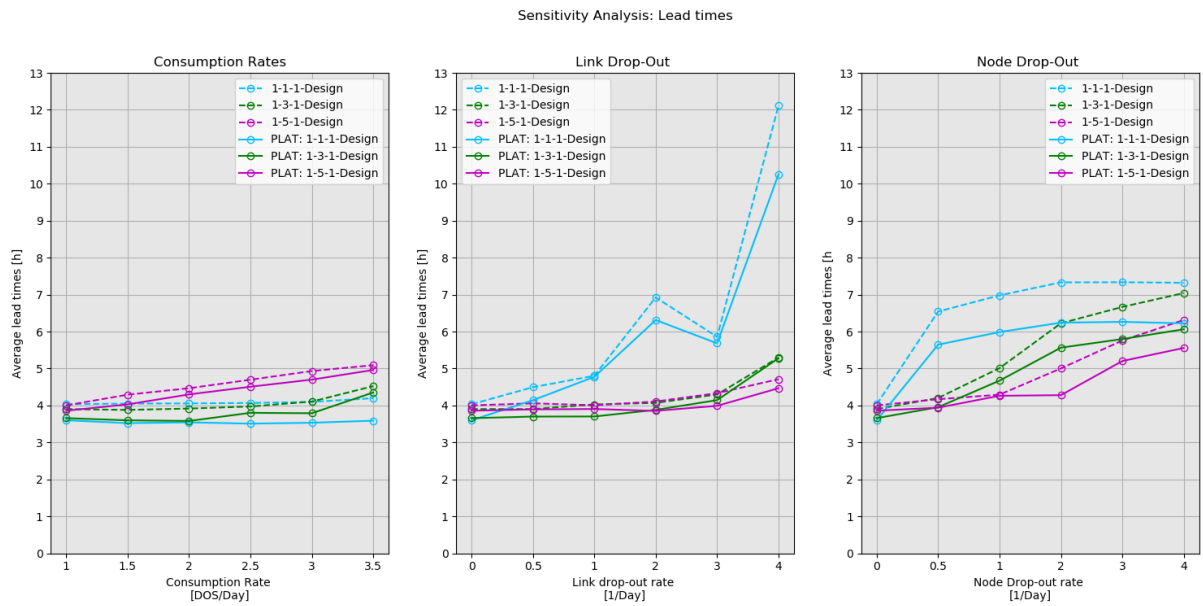

(a) A graph showing the lead time information of the sensitivity analysis. The results of implementing platooning are added.

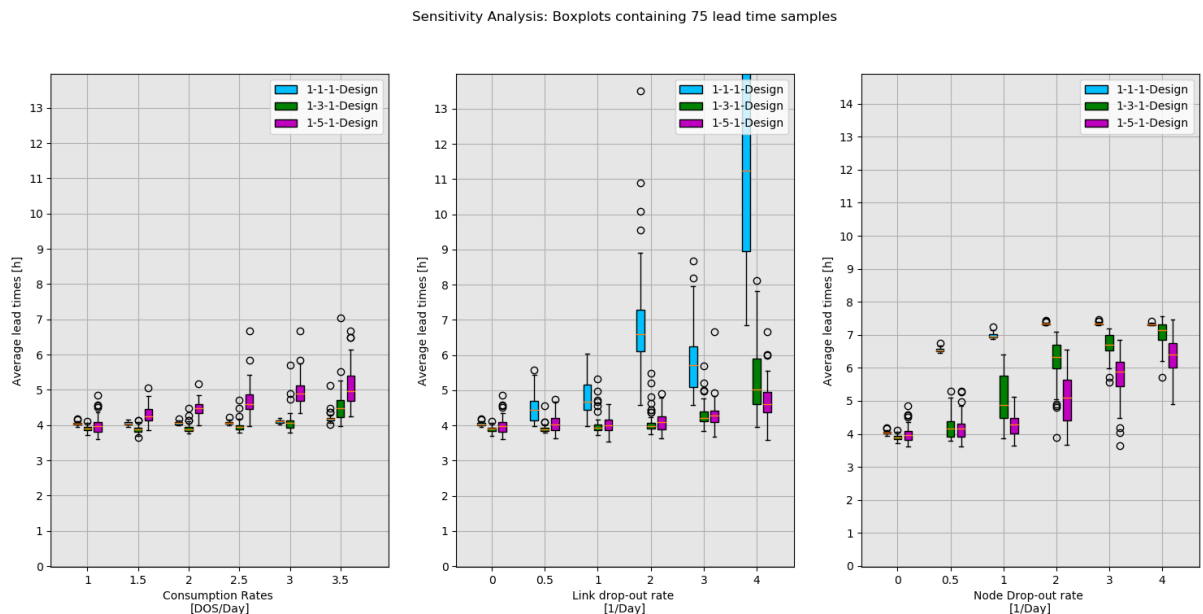

(b) A boxplot showing the lead time information of the sensitivity analysis.

Figure 7.8: Two figures containing the sensitivity analysis information about the lead time of three different designs.

The boxplots give a sense for the spread of the results and indicate indirectly how accurate the mean values are as plotted in the graphs above the boxplots. At high link dropout frequencies one can see an increase in result variation, meaning that the mean values become less accurate.

7.3.2. Load Cases

It is also good to see the combined effects of the node- and link drops and supply fluctuation. This section shows all graphs and tables that resulted from the load case experiments. Each graph is represented by the number of units that are involved in the design. These 3 graphs are grouped into one figure that contains all information about each KPI, so a clear overview of all different configurations can be seen at a glance. First figure 7.9 given an overview of

the stock levels performing under three different load cases.

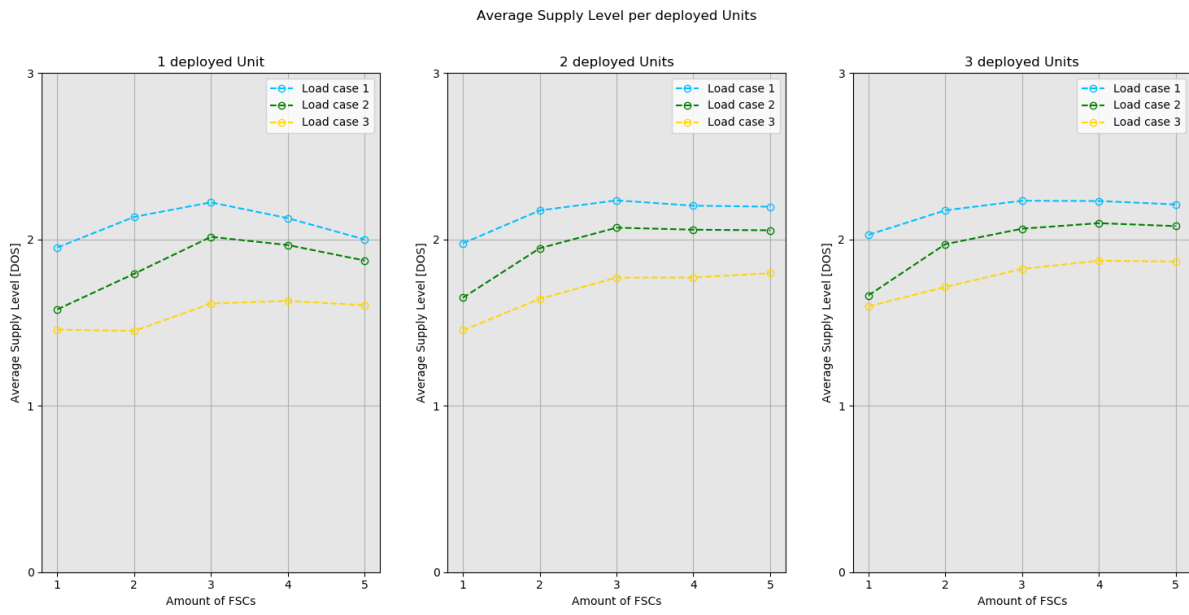

(a) Graph of stock level averages during 3 different load cases

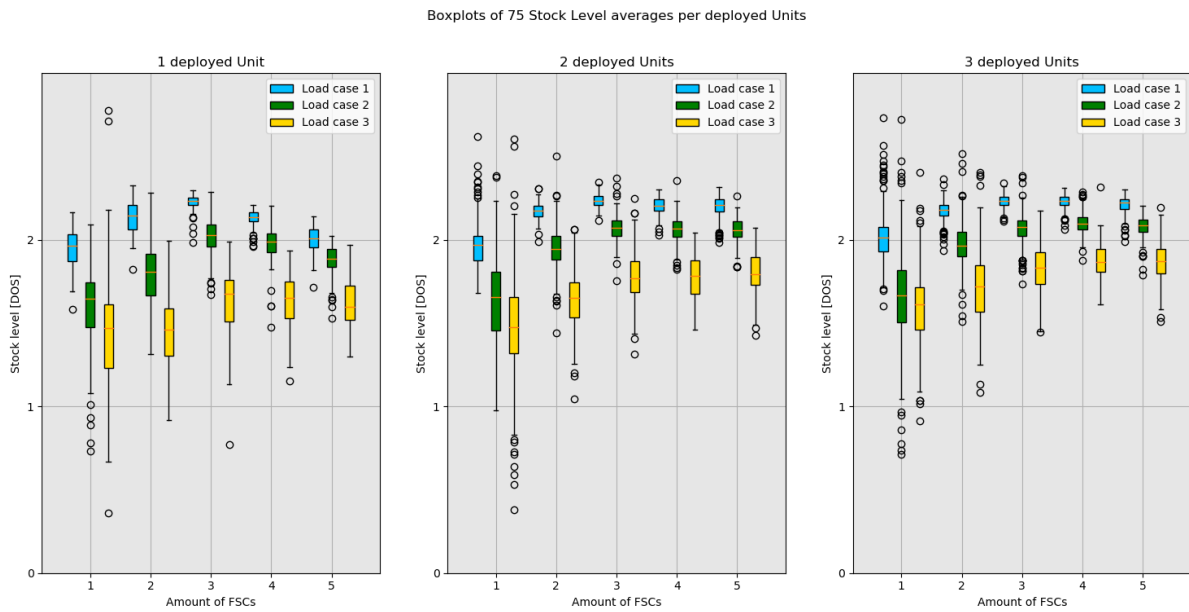

(b) Boxplot of stock level averages during 3 different load cases

Figure 7.9: Figures containing information about stock levels during separate load case tests

Figure 7.10 presents a graph and boxplot showing the order fulfillment percentage.

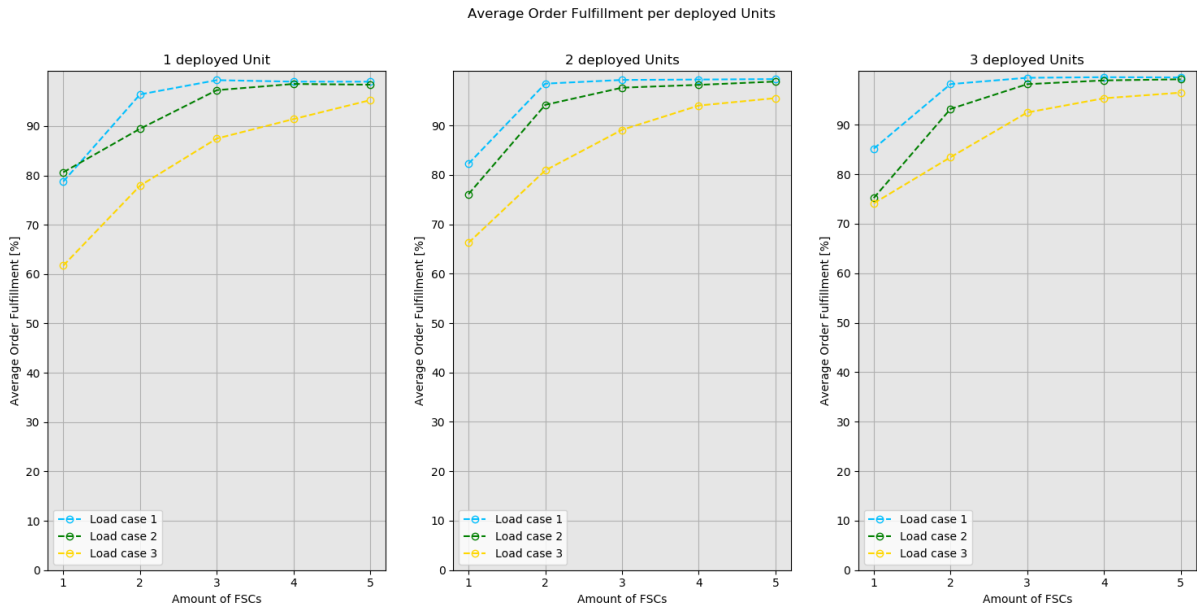

(a) Graph of order fulfillment averages during 3 different load cases

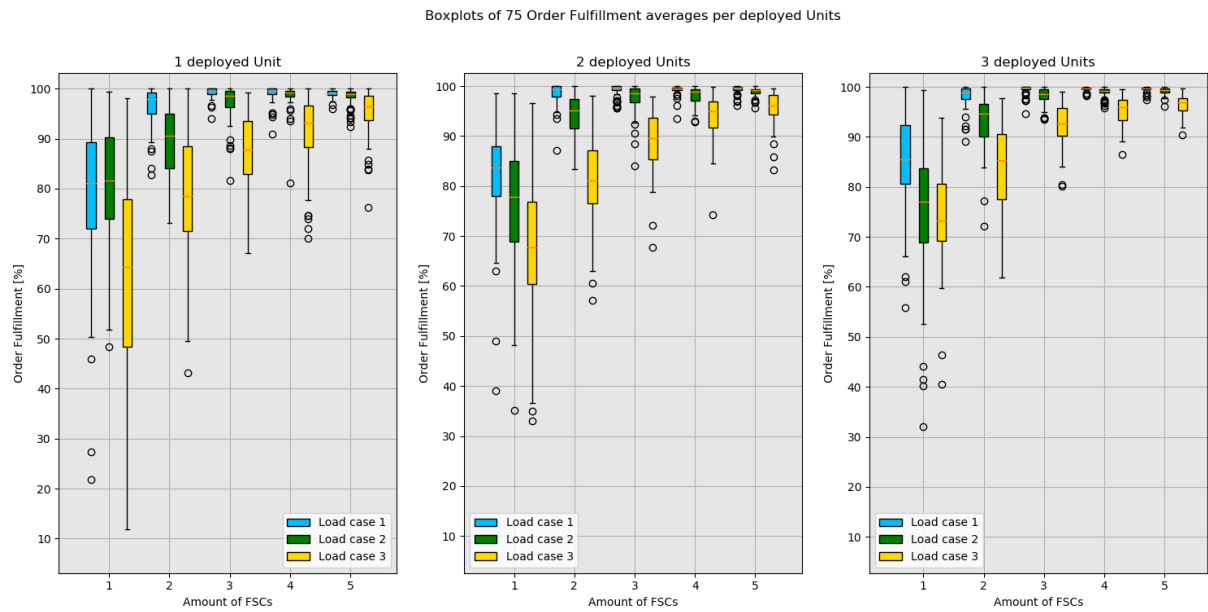

(b) Boxplot of order fulfillment averages during 3 different load cases

Figure 7.10: Figures containing information about order fulfillment during separate load case tests

Figure 7.11 shows the lead times and its relation with multiple networked FSCs and units under the three different load cases.

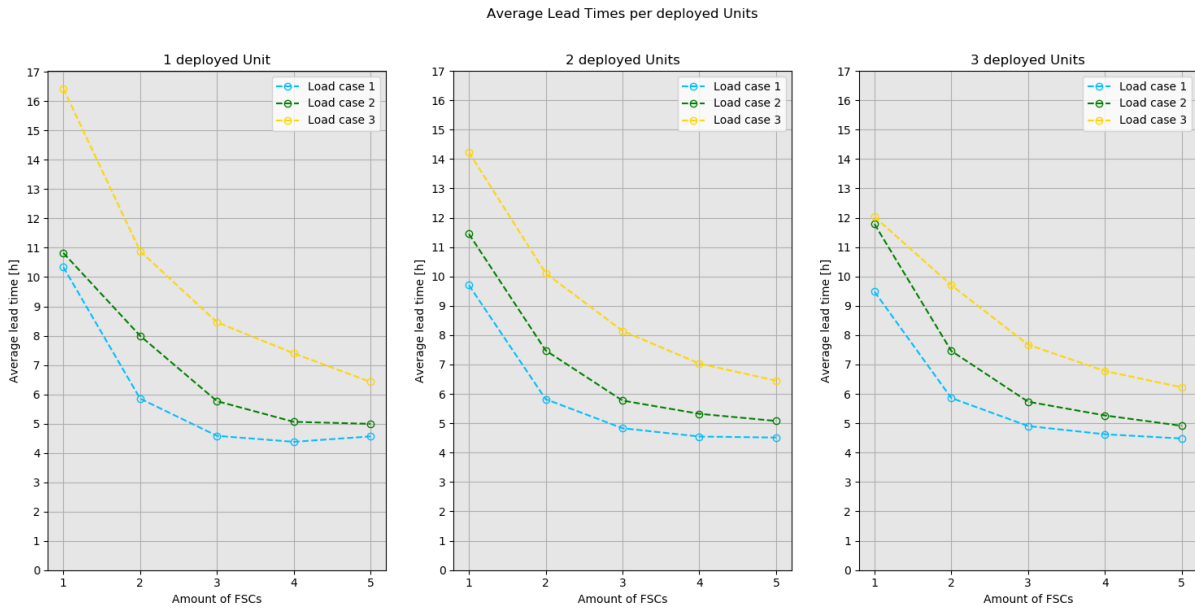

(a) Graph of order lead time averages during 3 different load cases

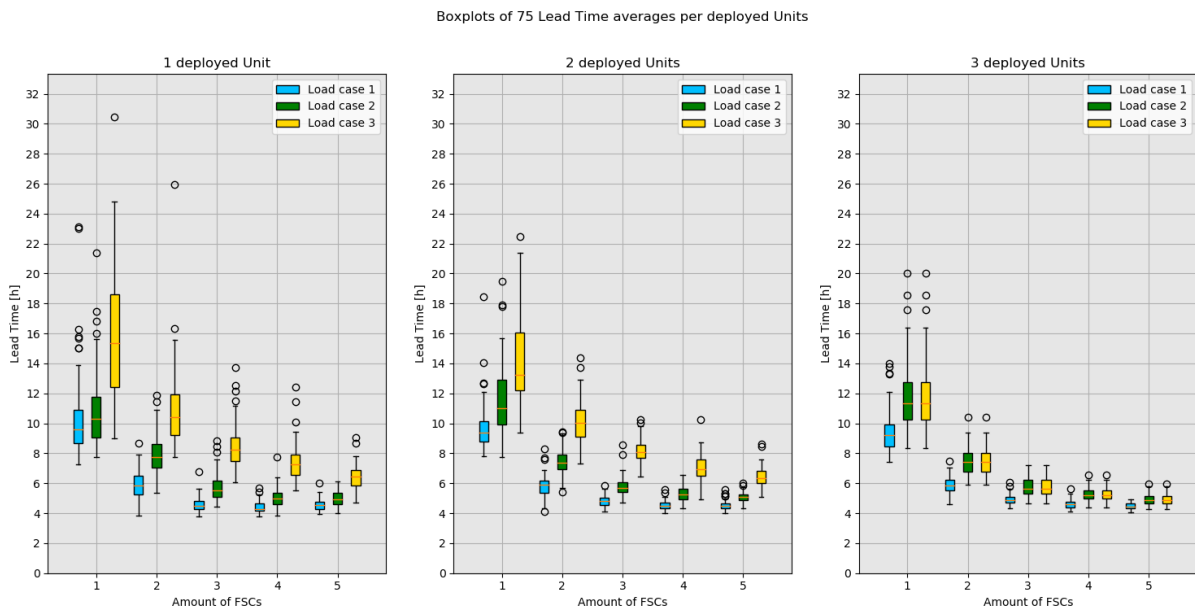

(b) Boxplot of order lead time averages during 3 different load cases

Figure 7.11: Figures containing information about lead times during separate load case tests

Tables 7.3, 7.4, 7.5 are presented, containing all KPI values of the load case tests. A relative improvement is calculated per unit design configuration. The table shows rounded values for ease of reading the table, percentages have been calculated with full numbers, the rounding errors. The bold numbers are the highest relative improvements per load case and unit time.

Table 7.3: Table containing all mean values of supply stock levels during load case testing

Load case	average stock levels [DOS]					Relative improvement [%]					Max impr.	
	1 FSC	2 FSC	3 FSC	4 FSC	5 FSC	1 FSC	2 FSC	3 FSC	4 FSC	5 FSC		
1 Unit												
LC 1	1.95	2.13	2.22	2.12	1.99	-	9.2	4.2	-4.5	-6.1	13.8	
LC 2	1.57	1.79	2.01	1.96	1.87	-	14.0	12.3	-2.5	-4.6	28.0	
LC 3	1.45	1.44	1.61	1.62	1.60	-	0.7	11.8	0.6	-1.2	11.7	
2 Units												
LC 1	1.97	2.17	2.23	2.20	2.19	-	10.2	2.8	-1.3	-0.5	13.2	
LC 2	1.64	1.94	2.06	2.06	2.05	-	18.3	6.2	0.0	0.5	25.6	
LC 3	1.45	1.64	1.76	1.77	1.79	-	13.1	7.3	0.6	1.1	23.4	
3 Units												
LC 1	2.01	2.13	2.27	2.27	2.27	-	6.0	6.6	0.0	0.0	12.9	
LC 2	1.62	1.95	2.07	2.09	2.09	-	20.3	6.2	1.0	0.0	29.0	
LC 3	1.51	1.76	1.82	1.87	1.89	-	16.6	3.4	2.7	1.1	25.2	

Table 7.4: Table containing all mean values of order fulfillment levels during load case testing.

Load case	Order fulfillment percentages [%]					Relative improvement [%]					Max impr.	
	1 FSC	2 FSC	3 FSC	4 FSC	5 FSC	1 FSC	2 FSC	3 FSC	4 FSC	5 FSC		
1 Unit												
LC 1	78.7	96.4	99.3	99.0	99.0	-	22.4	3.0	-0.3	0.0	22.4	
LC 2	80.6	89.5	97.3	98.5	98.4	-	10.9	8.8	1.3	-0.2	22.2	
LC 3	61.1	77.9	87.5	91.4	95.3	-	27.5	12.3	4.5	4.2	55.9	
2 Units												
LC 1	82.3	98.5	99.2	99.3	99.4	-	19.7	0.8	0.9	0.1	20.8	
LC 2	76.1	94.2	97.2	98.2	98.8	-	23.7	3.2	1.1	0.6	29.9	
LC 3	66.2	80.4	89.4	94.5	95.9	-	21.5	11.2	2.7	1.5	44.9	
3 Units												
LC 1	85.1	98.2	99.5	99.6	99.6	-	15.4	1.3	0.1	0.0	17.0	
LC 2	75.1	93.1	98.2	98.9	99.2	-	23.9	5.5	0.7	3.1	32.1	
LC 3	74.1	83.4	92.5	95.4	96.5	-	12.6	10.8	3.1	1.2	30.2	

Table 7.5: Table containing mean values of lead time during load case experimenting

Load case	Average lead times [h]					Relative improvement [%]					Max impr.
	1 FSC	2 FSC	3 FSC	4 FSC	5 FSC	1 FSC	2 FSC	3 FSC	4 FSC	5 FSC	
1 Unit											
LC 1	10.3	5.9	4.6	4.4	4.6	-	43.4	21.7	4.4	-4.5	59.6
LC 2	10.8	7.9	5.8	5.1	4.9	-	26.2	27.8	12.3	1.4	53.9
LC 3	16.4	10.9	8.56	7.4	6.4	-	33.7	22.3	12.5	13.2	60.9
2 Units											
LC 1	9.7	5.8	4.8	4.5	4.5	-	40.1	17.0	6.8	0.0	53.6
LC 2	11.5	7.5	5.8	5.3	5.1	-	34.7	22.9	7.8	4.5	55.6
LC 3	14.2	10.1	8.2	7.0	6.5	-	29.0	19.4	13.7	8.3	54.7
3 Units											
LC 1	9.5	5.9	4.9	4.6	4.5	-	40.1	16.4	5.5	2.2	52.37
LC 2	11.8	7.5	5.7	5.3	4.9	-	36.7	23.2	8.0	6.8	58.3
LC 3	12.0	9.7	7.7	6.8	6.2	-	19.4	20.8	11.7	8.3	48.2

Table 7.6 presents the combined robustness scores of every load case and supply chain design configuration. The score is calculated by calculating the mean value of all 3 relative improvement-values of the 3 KPIs.

Table 7.6: Table showing the overall, relative robustness increase.

Robustness "score" based on the mean of relative improvements of three different KPIs in [%].						
Number of Units	Load case	Number of FSCs deployed				
		1 FSC	2 FSCs	3 FSCs	4 FSCs	5 FSCs
1 Unit	LC 1	-	25.00	9.60	-0.13	-2.37
	LC 2	-	17.03	16.3	3.70	1.13
	LC 3	-	20.6	15.47	5.87	5.40
2 Units	LC 1	-	23.33	6.87	2.13	-0.2
	LC 2	-	25.57	10.77	2.97	1.87
	LC 3	-	21.2	12.63	5.67	3.63
3 Units	LC 1	-	20.5	8.10	1.87	1.07
	LC 2	-	26.97	11.63	3.23	3.3
	LC 3	-	16.2	11.67	5.83	3.53

The robustness score gives information about the relative increase of an upgrade to a design that has one more FSC added into the design configuration. When the score is negative, the total robustness is decreasing. If positive, the robustness still is improving. However, since adding more FSCs in general improves robustness, except with some cases of increased consumption rate, it is important to see how much robustness is increased. So one can get a feeling for what the optimum number of FSCs should be.

7.3.3. Case Study - A military operation near Mszanka

The case study investigates a specific scenario configuration closely related to a potential life-like situation. As is explained in the section experiments it concerns a possible defense operation near the town of Mszanka in Poland. As a design configuration, a 1-n-3-design is chosen. The n represents the FSCs and is being investigated. The scenario configuration is given in table 7.7 as well as the result of the study.

Graphs are presented in figures 7.12, 7.13 and 7.14. Showing the trend of each KPI versus the amount of possible FSCs.

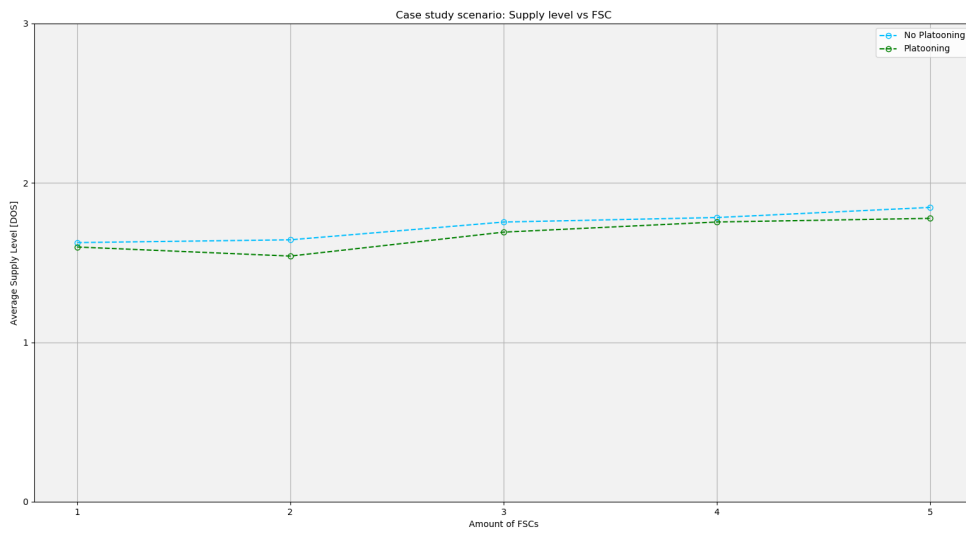

(a) A plot of the average supply levels versus the amount of possible FSCs.

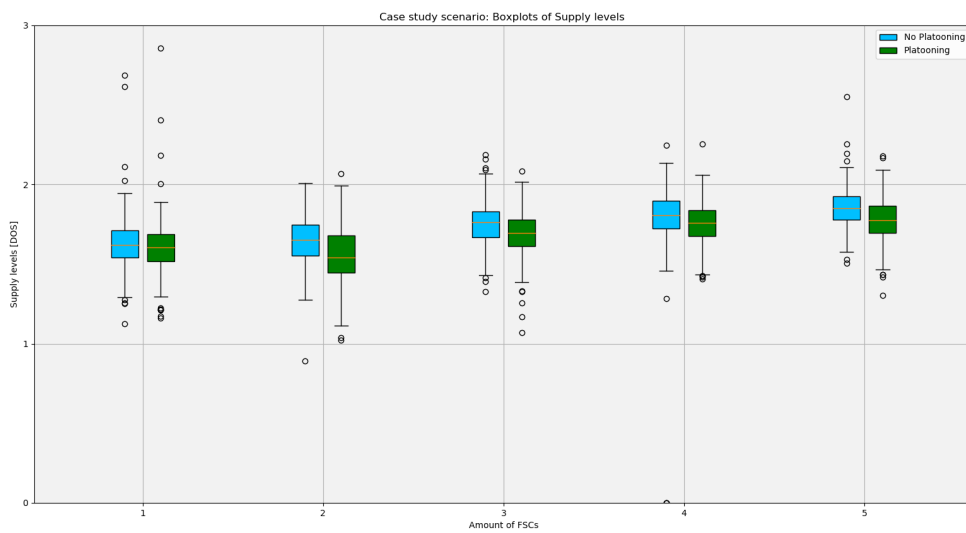

(b) A boxplot of supply levels versus the amount of possible FSCs.

Figure 7.12: Graphs containing information about supply levels versus the amount of FSCs

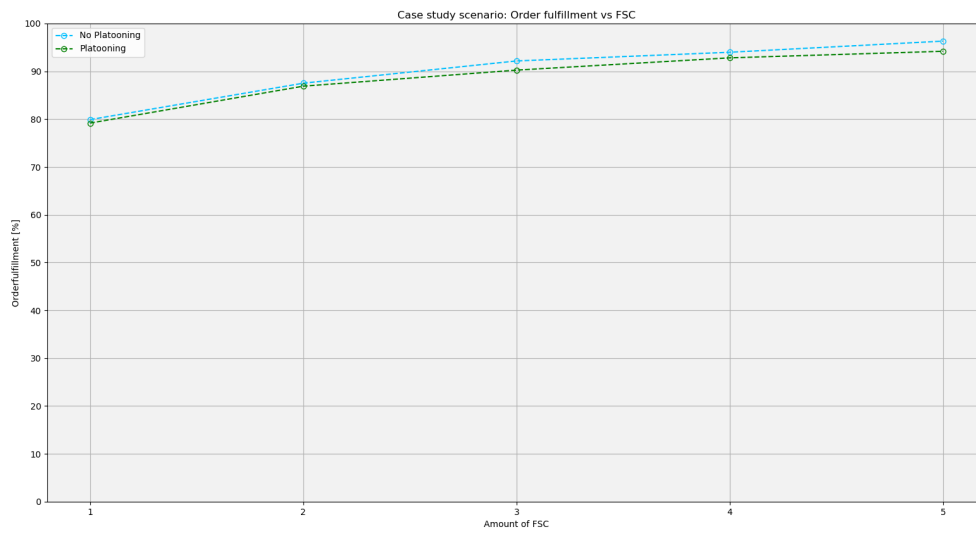

(a) A plot of the average order fulfillment versus the amount of possible FSCs.

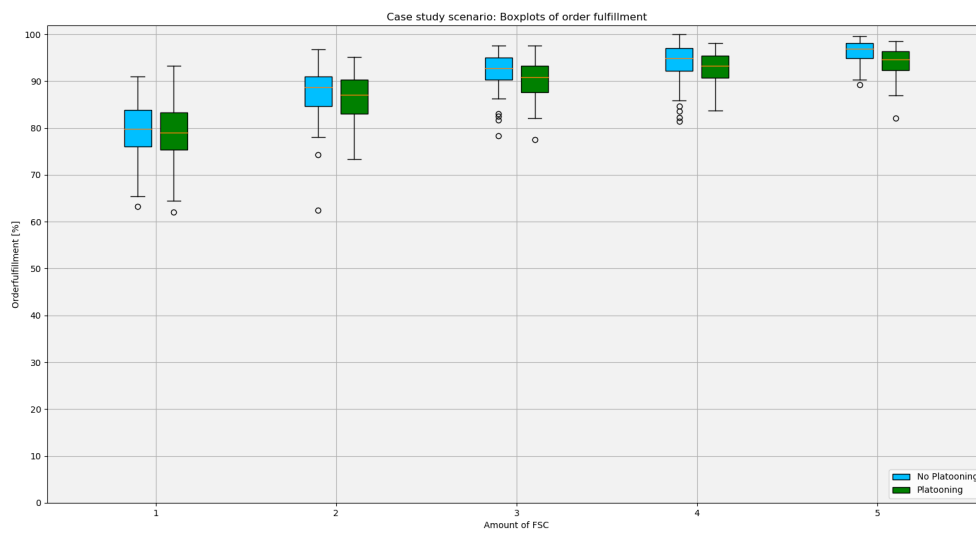

(b) A boxplot of order fulfillment versus the amount of possible FSCs.

Figure 7.13: Graphs containing information about order fulfillment versus the amount of FSCs

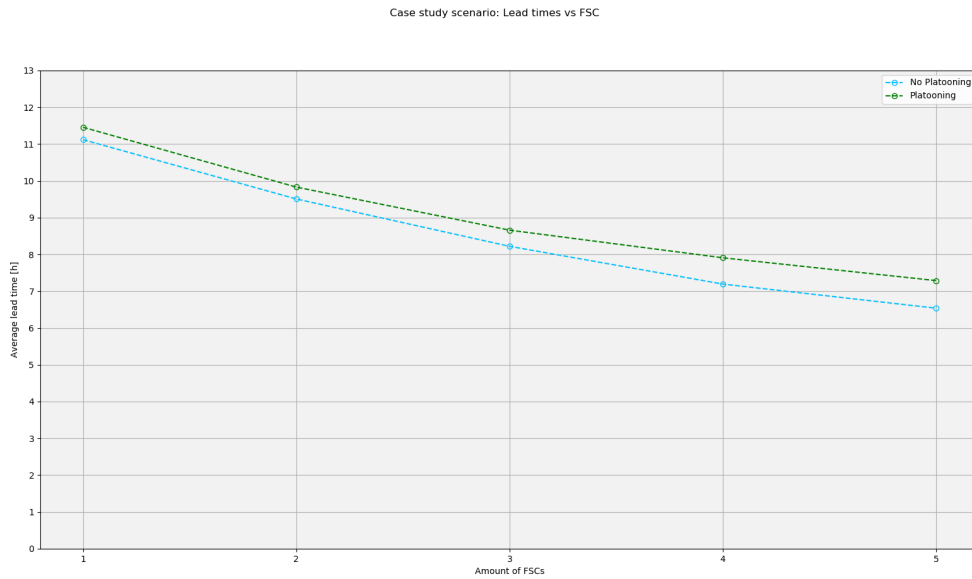

(a) A plot of the average lead times versus the amount of possible FSCs.

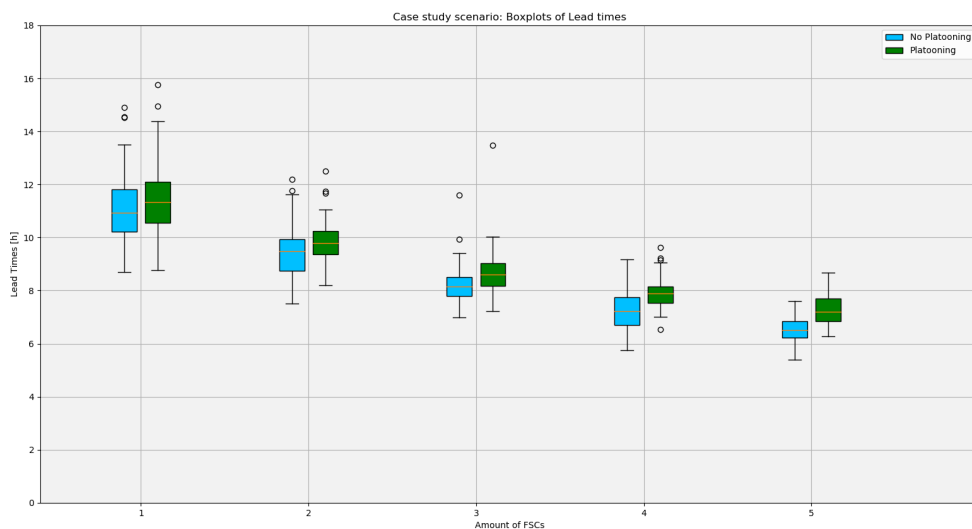

(b) A boxplot of lead times versus the amount of possible FSCs.

Figure 7.14: Graphs containing information about lead times versus the amount of FSCs

The table presents all mean and median values of the KPIs. The relative improvements are presented in table 7.7 as well. Table 7.7 the effect of platooning is shown in relative improvements as well, and a total robustness indicator is presented

The biggest difference is spotted in the 1-2-1-design when looking at stock level with a -6.1% lower score, -11.5% for lead times and -2.2 % at order fulfillment. Platooning score practically the best relatively to non-platooning at order fulfillment with only a difference of -0.7%. It can be seen that platooning never results in better outcomes for the KPIs that are observed.

Table 7.7: Table presenting results of the case study of the 1-n-3-design configurations. The mean value is given next to the median value.

IF : [1.25, 1, 3.12, 1.5, 1] Drop-freq: 6 [1/Day]							
Amount of FSCs	Stock levels	Lead times	Order fulfillment	Improv. Stock levels	Improv. Lead time	Improv. Order fulfillment	Robustness indication
No Truck Platooning							
1	1.63/1.61	11.12/10.94	79.91/79.84	-	-	-	-
2	1.64/1.65	9.51/9.49	87.53/88.66	0.6%	14.5%	9.5%	8.2%
3	1.75/1.76	8.22/8.16	92.17/92.78	6.7%	13.6%	5.3%	8.5%
4	1.78/1.81	7.19/7.22	93.99/94.83	1.7%	12.5%	2.0%	5.4%
5	1.85/1.85	6.54/6.51	96.32/96.97	3.9%	9.0%	2.5%	5.1%
Cumulative improvement				13.5%	41.2%	20.5%	25.1%
Truck Platooning							
1	1.60/1.60	11.46/11.33	79.18/78.99	-	-	-	-
2	1.54/1.54	9.83/9.78	86.90/87.10	3.8%	14.2%	9.7%	9.2%
3	1.69/1.70	8.66/8.6	90.26/90.84	9.7%	11.9%	3.9%	8.5%
4	1.75/1.76	7.91/7.90	92.82/93.28	3.6%	8.7%	2.8%	5.0%
5	1.78/1.77	7.29/7.19	94.20/94.65	1.7%	7.8%	1.5%	3.7%
Cumulative Improvement				11.3%	36.4%	19.0%	22.2%

Table 7.8: Case study: Relative improvements due to platooning.

Amount of FSCs	Stock level	Lead times	Order fulfillment
1	-1.8 %	-3.0%	-1.0%
2	-6.1 %	-3.4 %	-0.7%
3	-3.4%	-5.4 %	-2.1%
4	-1.6%	-10.0%	-1.3%
5	-3.0 %	-11.5%	-2.2%

7.4. Conclusion

The results of this chapter show several outcomes that are worth noting. Observations are discussed briefly in this conclusion. The interpretations and further findings are discussed in chapter 8.

The first experimental setup explores the sensitivity of separate variables related to the KPIs. Three standard model design configurations are tested. The different designs are named according to their amount of SC, FSCs, and units deployed respectively. The involved designs are 1-1-1-design, a 1-3-1-design, and a 1-5-1-design.

- Stock levels: A strong relation between demand fluctuation and stock level can be noticed. When deploying a single FSC stock levels drop quite linear with the increase of number FSCs. The effect is amplified when deploying multiple FSCs. Link and node drops do not directly impact the stock level averages. This is according to expectations.
- Order fulfillment: Order fulfillment seems unaffected by increased consumption rates. Link drops seem to have to affect the 1-1-1 design the most. Node drops do impact the order fulfillment, but not that severely.
- Lead times: Lead times are influenced most by link and node drops and do increase with the number of deployed FSCs
- Platooning: truck platooning only seems to have a negligible influence on consumption rates and minor influences at stock level management. Order fulfillment and lead time do show some minor differences in favor of platooning.

The second experimental setup tests all possible models subjected to three kinds of created load cases. One load case is a package that combines different scenario variables. Load cases are created due to limited computing power. The load cases are created in such a manner

that the total of stresses that the supply chain experience is increased per load case, allowing us to still test the performance of a supply chain and express it in robustness. The model design configuration is a variety of 1-1-1-Design up to 1-5-3-Design and all configurations in between.

- Stock levels: In general all stock levels increase when implementing an increased amount of FSCs. For stock levels, there seems to be an optimum when a 1-3-1 design is applied.
- Order fulfillment: Order fulfillment show an increasing trend as well, with an increasing amount of FSCs.
- Lead times: Lead time decrease with an increase of FSCs.

Thirdly the case study is investigated. The case study involves a specific scenario, designed for a life-like situation in possible near-future deployment. The case study takes a location in the east part of Poland near the town Mszanka and deploys it in a fictional operational context.

- Stock level: For stock levels in case study only a minor increase is observed with the implementation of multiple FSCs, platooning shows a minor difference. Influencing the supply chain stock level management in a less favorably manner.
- Order fulfillment: With an increasing number of FSC, a better order fulfillment percentage is witnessed. Truck platooning has a negligible difference in performance.
- Lead times: Lead times decrease as the amount of FSCs increase, platooning in the most linear example has a negligible difference, but when operating fully networked, the difference is substantial.

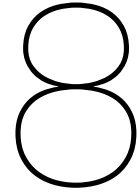

Findings and Insights

This chapter discusses the major findings and insights of this graduation research. The goal is to answer the main research question of this thesis and elaborate the results a bit more in general.

Here the main research question that has to be answered is stated:

How to design a robust supply chain for military operation considering platooning?

8.1. Sensitivity Findings

- Stock levels:
 - placing multiple amounts of FSC does not seem to help to increase the stock level at one unit. Initially, at baseline stock level is a discrepancy of 0.24 DOS between a 1-1-1-design and 1-5-1-design. This discrepancy increases when a high consumption rate is applied up to 0.83 DOS, resulting in a 246 % increase of discrepancy. At 3.5 DOS consumption rate a 1-1-1-design can assure about 60.0% stock level, a 1-5-1-design only achieves just above critical 32.2%.
 - For the 1-5-1-design there is 1 DOS difference when consumption rate increases by a factor 3.5, a significant influence. It can be concluded that networked operating does not profit of a higher stock level. This can be explained, when operating in a networked manner, the sum of stock level at FSCs is still 4 DOS, when dividing these 4 DOS over 5 FSCs less than a DOS of stock is available at each FSC, as soon as orders are created, larger than 1 DOS, the convoys that need to be created are more dispersed throughout the system, making convoy creation take longer, resulting in longer lead times and thus lower stock level averages as time progresses.
 - when looking at link- and drop-out no significant difference are observed, except a decreasing stock level for the 1-1-1-design. This is due to a relatively high link block fraction at a 1-1-1-design. Platooning does not seem to influence these results notably. This would mean that when operating in a supply chain that has high consumption rates and low link or node drop-outs a 1-1-1-design would still be preferred. This is in line with literature that describes a military supply chain as an agile supply chain, meaning that redundancy in stock levels is a good way to counter demand uncertainty. When looking at a single FSC in a 1-1-1-design it has a higher stock level than a single FSC at a 1-5-1 design.
- Order fulfillment:
 - Order fulfillment is not significantly influenced by consumption rates. A slight increase when operation in 1-1-1-design, again mostly due to the same reason as to looking at the relations of stock levels and consumption rates.

- Link drop-out sees a significant drop when operating in a 1-1-1-design, a drop from 95.0 % to 57.3 % can be seen, almost halving the order fulfillment, harming the supply chain in a major manner. A 1-3-1-design has a significantly higher resistance to node drops, due to the increasing amount of links available. Performing 65.8% better when comparing to a 1-1-1-design. A 1-5-1-design performs even better but has just in relative increase to a 1-3-1-design of 6.1%.
 - The node drops show no significant decrease in order fulfillment, a 1-5-1-design resists node drops the best. When node drops occur, the destinations of order can be reallocated to a secondary supply node (FSC or SC). When looking at a 1-1-1-design, one would expect node drops to harm order fulfillment the most, however, orders can be relocated to an SC, and still arrive in full and in time.
- Lead times:
 - As expected by the observation of stock levels, it now can be seen that an increase of lead time influences those stock levels. The 1-5-1-design has higher lead times with increasing consumption rates, therefore influencing the stock levels in a negative manner.
 - The link drop frequency does significantly influence the lead time for a 1-1-1-design, and one can observe the beginning of an inclination of lead time for the 1-3-1 and 1-5-1 only at the highest drop out frequency. A 1-3-1-design has a relative 153,5% better performance. The lead times will eventually converge to infinite because an increase of link drop frequency will in the end result in disabling all transport routes.
 - For node drops the dependencies show different behavior and seems to reach an asymptotic value of 7,5 hours. Since in the model SC drops are not applied, the asymptotic value of 7,5 hours is equal to the time a transport directly from SC to the unit is facilitated. It can be observed that 1-3-1- and 1-5-1-design are less or lesser influenced by node drops, however will eventually converge to the 7.5 hours value as well.

Furthermore, it is noticed that the axes of the graphs of link- and node-drops aren't as linear as they appear. At the x-axes, the node and link drop frequency is displayed, however, the increase of node- or link drop rate with 1 step, is not linear if one keeps increasing the rate with one additional dropout per day. In figure 8.1 the same lead time values of a 1-1-1-design are plotted against the linear inter-arrival time of node or link drops.

A curve fit has been done and now we can see the real dependencies of inter-arrival time and lead times. The first fitting, for link-drop, is an exponential fit that suited best, the second fitting for node-drops seem linear but is a square-root function.

8.2. Load case findings

- Stock levels:
 - In the graphs of the stock level versus number of FSCs, an increase is seen in stock levels when the number of FSCs increases. An Exception is seen when only 1 unit is deployed, meaning 1-n-1-designs. at 1-3-1 there seems to be an optimum in the amount of deployed FSCs. This seems odd, however, when remembering the sensitivity analysis, a decrease in stock level was observed, when the number of FSCs increases. It was said that stock level under low drop-out rate prefers less FSCs. When load case 1 is applied, having a very low drop-out rate of links and nodes, one can see that optimum. When 2 or more units are deployed an optimum is found as well. However, no significant decreases in stock levels are observed after deploying 3 FSCs.
 - As the load cases increases in severeness, there is a drop in performance, which is according to expectations, heavier load cases result in the higher stressed supply chain. It is, however, important to see the relative gains in performance when

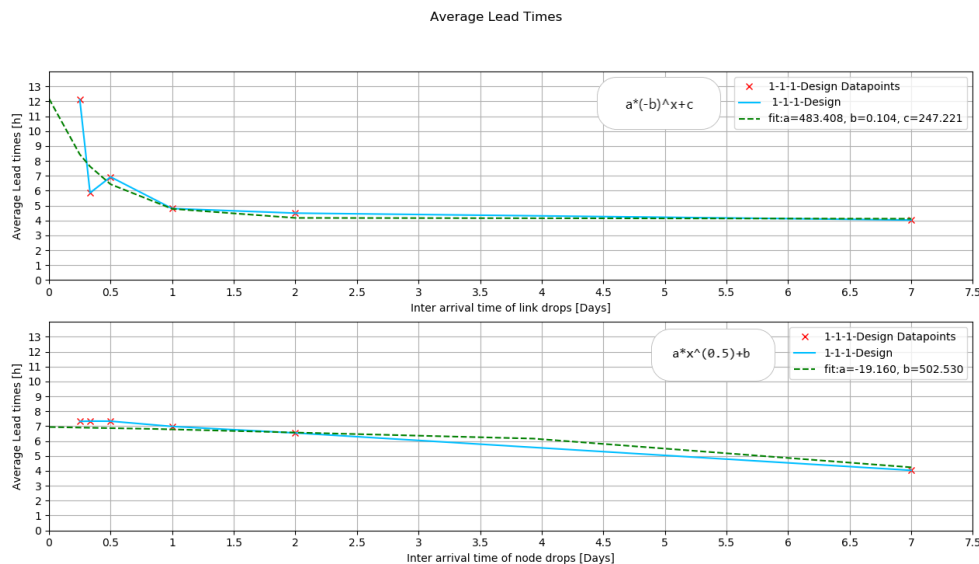

Figure 8.1: Figure of lead times put on a linear scale of link drop and node drop inter arrival time. Clearly shows the relation between inter arrival time and lead times of a 1-1-1-Design.

deploying an extra FSC. These are shown in table 7.6. Where relative robustness increases are displayed in percentages. In general, deployment of a second FSC shows a significant boost in every model design. When deploying a third FSC, this boost is reduced a lot.

- When looking at the relative improvements, an optimum is reached when deploying 2 FSCs. However, when deploying a third FSC an additional increase of robustness between 6.8% and 16.30% can be seen.
- Order fulfillment:
 - The graphs clearly displays how order fulfillment percentages are benefiting an increase of FSCs in all supply chain design. For load cases 1 and 2 an optimum is found at 2 or 3 FSCs when deploying one unit. When two or three units are deployed, this optimum is found at 2 FSCs.
 - Load case 3 seems to be benefiting the most of deploying multiple FSCs. The relative increase when one unit is deployed is the most significant. A discrepancy of 19,4% converges to 3.0% when comparing with load case 1.
- Lead times:
 - Lead times decrease are observed with an increase of FSCs. When deploying one unit, this is seen best. Optimums can be seen around 4 FSCs for load cases one and two. A slight increase in lead time is observed in a 1-5-1-design . This is again in line with the observation in the sensitivity analysis. Where an increase of FSCs leads to increase of lead times, due to the distribution of supply over multiple FSCs.
 - High lead times are observed for heavier load cases, as expected due to higher drop out rates.

8.3. Case study findings

- Stock level:
 - Stock levels for the case study do not benefit greatly when deploying multiple FSCs. There is a slight increase observable, this is about 13% relative increase between a 1-1-3 and 1-5-3 design. Still, the stock levels are 1.85 DOS in a 1-5-3-design, not critical, but leave a lot for improvement.

- Platooning does not bring any benefits, although impacting the stock levels a lot in a negative manner.
- Order fulfillment:
 - The absolute difference in order fulfillment between a 1-1-3 and 1-5-3-design is 16.4 %. However relative to 1-1-3-design results in 20.5% improvement.
 - When incorporating platooning, the discrepancy of order fulfillment increases when the amount of FSCs increase. Therefore making platooning not beneficial for order fulfillment
- Lead time:
 - Lead times show a significant decrease in lead time. When comparing the 1-1-3-design and 1-5-3-design an absolute difference of 4,5 hours can be observed, resulting in a relative decrease in lead times of about 41.2%. After 4 FSCs the slope decrease and only 9.0% relative decrease is observed.
 - Platooning does not improve the lead time over the complete trajectory between 1-1-3-design and 1-5-3-design.

8.4. Summary Robust Supply Chain

This section concludes the findings of the possible supply chain designs. Answering the main research questions:

How to design a robust supply chain for military operation considering platooning?

When looking at the sensitivity analysis, more deployed FSCs result in a decrease of stock level for high consumption rates, therefore the amount of FSCs should be as low as possible. However for lead time and order fulfillment a higher amount of FSCs is desired, to make the supply chain withstand a high rate of link and node drops. Advised is to go with 3 FSCs, as an optimum of the total chain. Meaning that a 1-3-1-design gives the best configuration.

This can be seen as well in the load cases that research all possible configurations under certain load cases. Here most relative gains in stock levels, order fulfillment and lead times are gained up to 2 or 3 FSCs. When implementing more FSCs, improvement continues, however not at such high rates as up to 3 FSCs and sometimes even drop. Table 7.6 shows the relative robustness score that is based on the average of relative improvement of the single KPIs.

Under the most extreme load cases, the fully networked operating is always advised, due to its ability to withstand node- and link-drop much better. This will come at the cost of stock level. However, stock levels only drop faster when high consumption rates are in full force and effect. When realizing that a consumption rate of 2.0 up to 3.5 means that a unit consumes 2.0 to 3.5 times the amount of prescribed DOS, one can imagine that this is quite extreme. It is thus more likely that higher node- and link dropouts occur, comparative to high consumption rates. Therefore making deployment of more than three FSC more likely to gain in robustness.

It should be said that the robustness score is the mean value of three different KPI performances, thus having equal weight. It is dependent on the situation and to the likings of the supply chain designer, to attach specific weights for specific KPI performances. When applying those weights, different advises can roll out of the supply chain designs.

As for the RDLF case study, A fully networked 1-5-3-design, compared to a 1-1-3-design of the supply chain results in an improvement of:

- 13.5% Stock level
- 20.5 % Order fulfillment
- 41.2 % Lead time

The relative largest improvements are observed up to 2 FSCs as well. As for the complexity of organizing a supply chain, this would be the way to go. However, keep in mind that this is only the case in the scenario design of this specific case study.

8.5. Summary for Platooning

Truck platooning has been considered alongside the design of a robust supply chain. Truck platooning does not seem to be suited within a fully networked supply chain. Discrepancies between operating non-platooning and platooning operations seem only to increase when going towards a more networked supply chain.

Platooning however should not be completely forgotten, there are other segments of a military supply chain, that might be more suited for this technology. When reflecting at the literature about platooning, it was found that almost every benefit of platooning in civil industries aren't really relevant for military applications. Besides the discussion of whether or not platooning is suited for this trajectory of the supply chain, one should know that the results about platooning presented in this research have been created with a certain setup of the simulation model. In this model the valuable aspects of platooning that seem relevant for robustness checking are incorporated, however, there are many more factors that decide if this technology is suited in certain parts of a supply chain. Meaning that a different view upon the opportunities might influence future platooning performance. In future the technology might have been developed even further, and open up other possibilities for implementation in the supply chain and making platooning more suited for in a military context. All in all, the verdict of this research is that supply chain robustness does not benefit from truck platooning.

9

Conclusion

This chapter concludes the research of investigating robustness of a supply chain for military operations. Also an answer to the last sub-question is provided:

How can we generalize the findings for networked supply chain problems outside military environments?

One of the biggest issues in all supply chains is uncertainty in supply and demand. This behaviour is even more unpredictable in a military context. Here peak demands and possible hindered supply routes make designing a supply chain quite hard. The answer to these supply insecurities is an increase in robustness of the supply chain. This translates into the capacity of the supply chain to adapt to new environments to operate the supply chain, and the capacity to respond quick to heavy fluctuations.

The department of defense did have a conceptual design of a supply chain that is supposed to increase robustness, these adaptations involve:

1. Networked operation of forward supply centers.
2. Truck platooning technology.
3. Implementation of "Notice to Move".

Networked operations mean a more dispersed manner of resupplying the deployed units during operations. A concept to achieve this is by deploying multiple smaller forward supply centers to increase supply security. Truck platooning refers to the relatively new technology where trucks can form convoys where only the leading truck is manually operated, the rest of the convoy is automated. This should reduce the amount manpower needed to operate a supply chain.

These new requirements sound promising, but there is no knowledge about the actual impact on robustness. This research incorporates all these requirements into a single model and couples robustness to three indicators; stock level, order fulfillment, and lead time, in an attempt to quantify robustness. This is done by creating a multi-agent simulation model in python, using a discrete event simulation package. Demand and supply uncertainty are simulated by incorporating fluctuating consumption rates of units, link- and node-drop out respectively. These are identified as the variables that influence the overall performance. A truck platooning module is implemented to check the effect of this technology. To resemble a life-like supply chain and get the right output, the "Notice to move"- ability should be emulated as well. To do this a distance-based swarming algorithm is implemented into the model. In order to ensure optimized supply level management at the unit-level, an integer optimization module using CPLEX integer optimization has been created to monitor stock levels of deployed units.

The research project started with extensive literature research on different information sources. Academic papers, internal documentation of the DoD, business documentation and interviews were the main sources of gaining insights and knowledge about:

- Supply chain management
- Truck platooning
- Simulation and modeling techniques
- Multi-Agent systems

Further, some more applied knowledge about military supply chains is extracted from internal documentation of the department of defense and the Royal Dutch Land Forces, truck platooning has been evaluated to see to what end it can be implemented. In order to do this, literature findings and requirements found in internal documentation are combined and the essentials of platooning for the model were extracted. Thereafter the supply chain is systematically analyzed, in order to get an understanding of all important flows, processes, and instances involved in the supply chain. A discrete event model is created that can perform real-time simulations giving valuable insights into the supply chain and key performance indicators that are related to robustness. Experiments are performed resulting in some interesting findings and insights in networked operations of supply chains. Furthermore, a small case study is developed and tested in order to give a piece of tailored advice for robust supply chain design for the Royal Dutch Land Forces.

Out of these experiments was concluded that networked operations, in general, will significantly improve the robustness of the supply chain. However, optimal performance do not per-se require a fully networked supply chain. This is also dependent on the supply chain designers preferences and demands concerning robustness. There is an optimum spotted around two to three networked forward supply centers. Platooning is considered to be not suited in the context of this research, meaning not suited in operational part of the supply chain. This does not render truck platooning fully useless in other parts of the supply chain or when considering future improvements of the technology. Although the research did use a military context to explain and show the robustness in a supply chain, when taking a step back, one can see that this research could be about every type of supply chain that has a similar configuration as the supply chain design of the Royal Dutch Land Forces. It is no more than a "standard" three-echelon, multiple-tiers supply chain, that many industries can relate to. In a military context link- and node-drops are due to blockade or disruptions during operation, mainly due to hostile events, however node drops in a civil industry could represent in a supplier unable to provide supply or natural disasters blocking transport routes, the model parameters' can be adjusted to resemble such situations as well.

Two especially interesting applications of the highly mobile supply chains we encountered during this research. Both examples involve different industries that are going to need mobile forward supply centers. On the 5th of September 2019, Albert Heijn, one of the major supermarkets in the Netherlands, is going to start a test with mobile supermarkets. Those supermarkets do not need personnel and can be relocated to every place Albert Heijn wants to, wherever there is high demand.

"Customers want to access their groceries everywhere when needed. This store is so small, it can be stored within a truck and moved around anywhere. We see the possible opportunities"
- Project lead at Albert Heijn - Jasper Hoogers. (source: nu.nl)

Another good example of a highly mobile supply node and a forward supply center is a new project in Germany. Here a possible project about medical busses, named "DB medibus" has started. It is a highly mobile medical outpost that can drive to several locations and is meant for supplying medical services in rural areas of Germany. This is yet another example of highly mobile supply nodes in a supply chain that could result in interesting applications[75].

10

Recommendations

This chapter lists the recommendations about several aspects that are encountered during the research that. There are some key points that could be explored in more detail in future research.

- Due to limited time and computational power, the model was not able to expand the amount of SCs deployed in field or increase the number of networked FSCs. Expected is that expanding the amount of SCs will have some interesting effects on the supply chain, especially when looking at node drops at SC level as well. There are concepts of supply chain designs at the RDLF that incorporate multiple smaller, and perhaps networked, SCs. In other industries, multiple suppliers are involved in a supply chain as well, so it is worth investigating the effects of robustness when operating with multiple SCs.
- The model has a lot of parameters that needed to be determined, before experimenting could be done. However, when considering some parameters as possible variables, further interesting discoveries connected to robustness could be brought to light. For example by varying stock level capacities, adjusting distances of units relative to FSC or SC, increasing velocities, limiting the number of trucks available or adjusting recovery times of SC/FSC/links after a drop-out. A lot of potential gains are to be discovered if these could be investigated in more detail.
- More in-depth risk assessment concerning link- and node- drops is needed. This model sets the number of dropouts per day. In reality, this is certainly not the case. There might be several days that multiple dropouts occur or days were none are experienced. Furthermore is the chance of a drop out dependent on multiple factors. These factors are mainly:
 1. Distance relative to front units
 2. Threat-level in the area
 3. Surface and volumes of the entities in the field
 4. Accuracy of weapon systems

It could be a complete study on its own to do these risk assessments and calculate the impact of drops of a truck or supply center. Another addition to detailed risk assessment could be the effect of smaller lead times of orders. When trucks delivers faster to units, it could mean that the truck would have less risk of being taken out during transport, in its turn resulting in a more robust supply chain.

- The possibility of fully autonomous transportation is not explored by this research, platooning might not be useful in this context of the research, but fully autonomous transportation could make a real difference. Autonomous transportation could eliminate the idea of de-central forward supply centers and replace them with a completely

dispersed supply network. Reducing the chance of being spotted and overall impact when just one single truck drop outs.

- The model created has the possibility of letting units move across the deployment field and automatically generate new FSCs if needed. However these features of the model have not been used so far. Increasing distances due to advancing or retreating could significantly impact the supply chain performance. Resulting in a shift in the needed amount of FSCs along with the movement. Automatically generating FSCs could result in some interesting research opportunities concerning the deployment phase of a mission.
- When reducing the number of different supplies in the supply chain, the supply chain will have a smaller footprint while in operation. The effect of relieving the supply chain might result in a different configuration of the chain itself. Reduced amount of supply needed to be transported could be achieved due to technologies like 3D-printing or other self sustaining technologies.
- Genetic optimization or machine learning of the overall supply chain would present interesting figures in the possibility to reduce stock capacity at unit and FSC level. Making the supply chain more lean without jeopardizing the order fulfillment and stock levels. Less supply running through the supply chain, means less impact when link- or node-drops occur.
- The internet of Things is becoming more integrated into our daily lives and provides a lot of information. Research in the application of IoT into the military supply chain, could not only increase robustness due to tailor-made supply opportunities increasing the just-in-time concept to a next level.

Bibliography

- [1] -. GoogleScholar, . URL <https://scholar.google.nl/>.
- [2] -. Researchgate, . URL <https://www.researchgate.net/>.
- [3] -. Scopus, . URL <https://www.scopus.com/home.uri>.
- [4] Sameera Abar, Georgios K. Theodoropoulos, Pierre Lemarinier, and Gregory M.P. O'Hare. Agent Based Modelling and Simulation tools: A review of the state-of-art software. *Computer Science Review*, 24:13–33, 2017. ISSN 15740137. doi: 10.1016/j.cosrev.2017.03.001. URL <http://dx.doi.org/10.1016/j.cosrev.2017.03.001>.
- [5] Henk A. Akkermans, Paul Bogerd, Enver Yücesan, and Luk N. Van Wassenhove. The impact of ERP on supply chain management: Exploratory findings from a European Delphi study. *European Journal of Operational Research*, 146(2):284–301, 2003. ISSN 03772217. doi: 10.1016/S0377-2217(02)00550-7.
- [6] Jakob Axelsson. Safety in vehicle platooning: A systematic literature review. *IEEE Transactions on Intelligent Transportation Systems*, 18(5):1033–1045, 2017. ISSN 15249050. doi: 10.1109/TITS.2016.2598873.
- [7] M. Becker, B.-L. Wenning, C. Görg, J. D. Gehrke, M. Lorenz, and O. Herzog. Agent-Based And Discrete Event Simulation Of Autonomous Logistic Processes. (June 2014): 566–571, 2012. doi: 10.7148/2006-0566.
- [8] Carl Bergenhem, Henrik Petterson, Erik Coelingh, Christofer Englung, Steven Shladover, and Sadayuki Tsungawa. Overview of Platooning Systems. Technical Report 1, 2012. URL http://publications.lib.chalmers.se/records/fulltext/174621/local_174621.pdf.
- [9] D Bowersox, C David, and M Bixby Cooper. Logistical Management: The Integrated Supply Chain Process. Technical report, Michigan State University, 1996. URL https://www.academia.edu/31653226/Supply_Chain_Logistics_Management_-_Bowersox_McGrawHill.
- [10] Yongcan Cao, Wenwu Yu, Wei Ren, and Guanrong Chen. An overview of recent progress in the study of distributed multi-agent coordination. *IEEE Transactions on Industrial Informatics*, 9(1):427–438, 2013. ISSN 15513203. doi: 10.1109/TII.2012.2219061.
- [11] Maria Caridi and Sergio Cavalieri. Multi-agent systems in production planning and control: An overview. *Production Planning and Control*, 15(2):106–118, 2004. ISSN 09537287. doi: 10.1080/09537280410001662556.
- [12] John S. Carson. Simulation model verification and validation. *Winter Simulation Conference Proceedings*, pages 37–47, 2002. ISSN 02750708. doi: 10.1145/268437.268448.
- [13] Rui Carvalho and Luís Custódio. A multiagent systems approach for managing supply-chain problems: A learning perspective. *2005 International Conference on Integration of Knowledge Intensive Multi-Agent Systems, KIMAS'05: Modeling, Exploration, and Engineering*, 2005(2):454–459, 2005. doi: 10.1109/KIMAS.2005.1427124.
- [14] C. Caux, F. David, and H. Pierreval. Implementation of delayed differentiation in batch process industries: A standardization problem. *International Journal of Production Research*, 44(16):3243–3255, 2006. ISSN 00207543. doi: 10.1080/00207540500521543.

- [15] Danjue Chen, Soyoung Ahn, Madhav Chitturi, and David Noyce. Truck platooning on uphill grades under cooperative adaptive cruise control (CACC). *Transportation Research Part C: Emerging Technologies*, 94:50–66, 2018. ISSN 0968090X. doi: 10.1016/j.trc.2017.08.025. URL <https://doi.org/10.1016/j.trc.2017.08.025>.
- [16] Martin Christopher. The Agile Supply Chain: Competing in Volatile Markets. *Industrial Marketing Management*, 29(1):37–44, 2000. ISSN 00198501. doi: 10.1016/S0019-8501(99)00110-8.
- [17] Martin Christopher and Denis R. Towill. Supply chain migration from lean and functional to agile and customised. *Supply Chain Management*, 5(4):206–213, 2000. ISSN 13598546. doi: 10.1108/13598540010347334.
- [18] L. Chwif, M. Ribeiro Pereira Barretto, and E. Saliby. Supply chain analysis: spreadsheet or simulation? (1998):59–66, 2003. doi: 10.1109/wsc.2002.1172869.
- [19] D.P.A. Claus. *It takes a network to support a network*. PhD thesis, TIAS School for Business and Society, 2017.
- [20] Paul Davidsson and Fredrik Wernstedt. *A Framework for Evaluation of Multi-Agent System approaches to Logistics Network Management*. PhD thesis, Blekinge Unstitute of Technology.
- [21] M.C. De Gennaro and A. Jadbabaie. Formation control for a cooperative multi-agent system using decentralized navigation functions. *2006 American Control Conference*, page 6 pp., 2006. doi: 10.1109/acc.2006.1656404.
- [22] Nicholas de Larrinaga and Nikolai Novichkov. Russia ’ s armou revolution, 2015. URL <https://web.archive.org/web/20150517063353/http://www.janes.com/article/51469/russia-s-armour-revolution>.
- [23] J. De Turck. *The European Truck Platooning Challenge: Transforming Europe’s Road Transport on Autopilot*, 2017.
- [24] Debra van Opstal. The resilient economy: Integrating competitiveness and security. (July):1–49, 2007. doi: 10.2172/945030. URL <http://www.osti.gov/servlets/purl/945030-43KAur/>.
- [25] J. C.Q. Dias, J. M.F. Calado, A. Luís Osório, and L. F. Morgado. RFID together with multi-agent systems to control global value chains. *Annual Reviews in Control*, 33(2): 185–195, 2009. ISSN 13675788. doi: 10.1016/j.arcontrol.2009.03.005.
- [26] A. Djanatliev and R. German. PROSPECTIVE HEALTHCARE DECISION-MAKING BY COMBINED SYSTEM DYNAMICS, DISCRETE-EVENT AND AGENT-BASED SIMULATION. In *Proceedings of the 2013 Winter Simulation Conference*, pages 270–281, 2013. ISBN 9781479920778.
- [27] B. Dubiel and O. Tsimhoni. Integrating Agent Based Modeling into a Discrete Event Simulation. In *Proceedings of the 2005 Winter Simulation Conference*, pages 1265–1274, 2005.
- [28] H.E. Eccles. *Military Concepts and Philosophy*. New Brunswick, 1965. doi: 10.1175/1520-0477-6.8-9.123b.
- [29] Magnus Egerstedt and Xiaoming Hu. Formation constrained multi-agent control. *IEEE Transactions on Robotics and Automation*, 17(6):947–951, 2001. ISSN 1042296X. doi: 10.1109/70.976029.
- [30] Markus Ettl, Gerald E. Feigin, Grace Y. Lin, and David D. Yao. A Supply Network Model with Base-Stock Control and Service Requirements. *Operations Research*, 48(2):216–232, 2003. ISSN 0030-364X. doi: 10.1287/opre.48.2.216.12376.

- [31] J.W. Forrester. "Industrial Dynamics: A Major Breakthrough for Decision Makers". Technical report, 1958.
- [32] Fu-Ren Lin, Gek Woo Tan, and M.J. Shaw. Modeling supply-chain networks by a multi-agent system. *Proceedings of the Thirty-First Hawaii International Conference on System Sciences*, 5(c):105–114, 2002. doi: 10.1109/hicss.1998.648302.
- [33] Jonatan Gjerdrum, Nilay Shah, and Lazaros G. Papageorgiou. A combined optimization and agent-based approach to supply chain modelling and performance assessment. *Production Planning and Control*, 12(1):81–88, 2001. ISSN 09537287. doi: 10.1080/09537280150204013.
- [34] Andrew Greasley. A comparison of system dynamics and discrete event simulation. *2009 Summer Computer Simulation Conference. 13-16 June 2009*, pages 83–87, 2009. URL <http://dl.acm.org/citation.cfm?id=2349508.2349519>.
- [35] Simon Hallé and Brahim Chaib-draa. A collaborative driving system based on multiagent modelling and simulations. *Transportation Research Part C: Emerging Technologies*, 13(4):320–345, 2005. ISSN 0968090X. doi: 10.1016/j.trc.2005.07.004.
- [36] Youssef Abou Harfouch, Shuai Yuan, and Simone Baldi. An adaptive switched control approach to heterogeneous platooning with intervehicle communication losses. *IEEE Transactions on Control of Network Systems*, 5(3):1434–1444, 2018. ISSN 23255870. doi: 10.1109/TCNS.2017.2718359.
- [37] Patycja Hoffa and Pawel Pawlewski. Agent Based Approach for Modeling Disturbances in Supply Chain. *Communications in Computer and Information Science*, 430:144–155, 2014. ISSN 18650929. doi: 10.1007/978-3-319-07767-3{_}14.
- [38] Holland & Davis LLC. Business Resilience ... for Changing Times. (February):1999, 1999. URL www.hdinc.com/hotTopics/hot_topic_2-99.html.
- [39] Sanjay Jain, Russell W. Workman, Lisa M. Collins, Eric C. Ervin, and Andrew P. Lanthrop. Development of a high-level supply chain simulation model. *Winter Simulation Conference Proceedings*, 2:1129–1137, 2001. ISSN 02750708. doi: 10.1109/WSC.2001.977425.
- [40] Antoine Henri Jomini. *Summary of the Art of War Author:.* 1838.
- [41] Walid Klibi, Alain Martel, and Adel Guitouni. The design of robust value-creating supply chain networks: A critical review. *European Journal of Operational Research*, 203(2):283–293, 2010. ISSN 03772217. doi: 10.1016/j.ejor.2009.06.011. URL <http://dx.doi.org/10.1016/j.ejor.2009.06.011>.
- [42] A.M. Law and W.D Kelton. *Simulation modelling and Analysis*. Boston: McGraw Hill., 2007.
- [43] Armin Lawi, Nur Ilmiyati Djalal, and Aidawayati Rangkuti. Inventory model of supply chain management 3-echelon multi-tiers. *2017 5th International Conference on Cyber and IT Service Management, CITSM 2017*, (March), 2017. doi: 10.1109/CITSM.2017.8089254.
- [44] J. H. Lee and C. O. Kim. Multi-agent systems applications in manufacturing systems and supply chain management: A review paper. *International Journal of Production Research*, 46(1):233–265, 2008. ISSN 00207543. doi: 10.1080/00207540701441921.
- [45] K.L. Leiphart. Creating a Military Supply Chain Management Model. page 3, 2001.
- [46] K Lieckens and N Vandaele. Multi-level reverse logistics network design under uncertainty. *International Journal of Production Research*, 7543:23–40, 2012. doi: 10.1080/00207543.2011.571442. URL <https://doi.org/10.1080/00207543.2011.571442>.

- [47] Ping Lou, Zu De Zhou, You Ping Chen, and Wu Ai. Study on multi-agent-based agile supply chain management. *International Journal of Advanced Manufacturing Technology*, 23(3-4):197–203, 2004. ISSN 02683768. doi: 10.1007/s00170-003-1626-x.
- [48] C Macal and M North. INTRODUCTORY TUTORIAL: AGENT-BASED MODELING AND SIMULATION. In *2014 Winter Simulation Conference*, number Id, pages 1539–1548, 2014. ISBN 9781479974863.
- [49] Robert Maidstone. Discrete Event Simulation, System Dynamics and Agent Based Simulation: Discussion and Comparison. *System*, (August):1–6, 2012.
- [50] Kristin J. Malakorn and Byungkyu Park. Assessment of mobility, energy, and environment impacts of intellidrive-based Cooperative Adaptive Cruise Control and Intelligent Traffic Signal control. *Proceedings of the 2010 IEEE International Symposium on Sustainable Systems and Technology, ISSST 2010*, pages 1–6, 2010. doi: 10.1109/ISSST.2010.5507709.
- [51] Silvia Mastellone, Dušan M. Stipanović, Christopher R. Graunke, Koji A. Intlekofer, and Mark W. Spong. Formation control and collision avoidance for multi-agent non-holonomic systems: Theory and experiments. *International Journal of Robotics Research*, 27(1):107–126, 2008. ISSN 02783649. doi: 10.1177/0278364907084441.
- [52] M.A. McGinnis. Military Logistics : Insights for Business Logistics. *International Journal of Physical Distribution & Logistics Management*, 22(2):22–32, 1992.
- [53] Steven A Melnyk, Robert E. Spekman, and Edward W Davis. Outcome-Driven Supply Chains. *MIT Sloan Management Review*, 51(2):38, 2010.
- [54] Christopher Nowakowski. Cooperative Adaptive Cruise Control (CACC) for Truck Platooning: Operational Concept Alternatives. 2015. doi: UCB-ITS-PRR-2015-05. URL http://escholarship.org/uc/item/7jff9n5wm%5Cnhttp://www.escholarship.org/help_copyright.html#reuse%5Cnhttp://escholarship.org/uc/item/7jff9n5wm%5Cnhttp://www.escholarship.org/help_copyright.html#reuse.
- [55] Kwang Kyo Oh, Myoung Chul Park, and Hyo Sung Ahn. A survey of multi-agent formation control. *Automatica*, 53:424–440, 2015. ISSN 00051098. doi: 10.1016/j.automatica.2014.10.022.
- [56] Reza Olfate-Saber, Alex J. Fax, and Richard M. Murray. Consensus and Cooperation in Networked Multi-Agent Systems. 95(1):1–7, 2007. ISSN 00189219. doi: 10.1109/JPROC.2006.887293.
- [57] Reza Olfati-Saber. Flocking for Multi-Agent Dynamic Systems: Algorithms and Theory. 2004. URL <https://apps.dtic.mil/docs/citations/ADA462317>.
- [58] Michal Pěchouček and Vladimír Mařík. Industrial deployment of multi-agent technologies: Review and selected case studies. *Autonomous Agents and Multi-Agent Systems*, 17(3):397–431, 2008. ISSN 13872532. doi: 10.1007/s10458-008-9050-0.
- [59] Daniel Ploger, Leo Kruger, and Andreas Timm-Giel. Analysis of Communication Demands of Networked Control Systems for Autonomous Platooning. *19th IEEE International Symposium on a World of Wireless, Mobile and Multimedia Networks, WoWMoM 2018*, 2018. doi: 10.1109/WoWMoM.2018.8449782.
- [60] W Ren, R W Beard, and E M Atkins. Information consensus in multivehicle cooperative control: Collective group behavior through local interaction. *{IEEE} Control Systems Magazine*, 27(2):71–82, 2007.
- [61] Wei Ren. Multi-vehicle consensus with a time-varying reference state. *Systems and Control Letters*, 56(7-8):474–483, 2007. ISSN 01676911. doi: 10.1016/j.sysconle.2007.01.002.

- [62] Wei Ren, Haiyang Chao, Student Member, William Bourgeois, and Student Member. Experimental Validation of Consensus Algorithms for Multivehicle. 16(4):745–752, 2008.
- [63] Craig W Reynolds. Flocks, herds, and schools. *Computers & Graphics*, 21(4):25–34, 1987.
- [64] Tom Robinson, Eric Chan, and Erik Coelingh. Operating platoons on public motorways: An introduction to the SARTRE platooning programme. *17th ITS World Congress*, (October), 2010.
- [65] D. Schunk and B. Plott. Using simulation to analyze supply chains. In *Proceedings of the 2000 Winter Simulation Conference*, pages 1095–1100, 2002. doi: 10.1109/wsc.2000.899070.
- [66] Shuming Shi, Ling Li, Yu Mu, and Guanghui Chen. Stable headway prediction of vehicle platoon based on the 5-degree-of-freedom vehicle model. *Proceedings of the Institution of Mechanical Engineers, Part D: Journal of Automobile Engineering*, (5988), 2018. ISSN 09544070. doi: 10.1177/0954407018785736.
- [67] Pranav Kumar Singh, Sahil Sharma, Sunit Kumar Nandi, Roshan Singh, and Sukumar Nandi. Leader Election in Cooperative Adaptive Cruise Control Based Platooning. pages 8–14, 2018. doi: 10.1145/3267195.3267197.
- [68] John Sterman. Instructions for Running the Production-Distribution Game ” The Beer Game ”. Technical report, MIT, Systems Dynamics Group, Cambridge, 1984. URL <http://www.albany.edu/cpr/sds/>.
- [69] H. Su, X. Wang, and Z. Lin. Flocking of multi-agents with a virtual leader part I: With a minority of informed agents. *Proceedings of the IEEE Conference on Decision and Control*, 54(2):293–307, 2007. ISSN 01912216. doi: 10.1109/CDC.2007.4434066.
- [70] Christopher S. Tang. Robust strategies for mitigating supply chain disruptions. *International Journal of Logistics Research and Applications*, 9(1):33–45, 2006. ISSN 1367-5567. doi: 10.1080/13675560500405584.
- [71] Ingo J Timm, Ralf Schleiffer, Paul Davidsson, and Stefan Kirn. Agent Technologies in Logistics. (June 2013), 2003.
- [72] M. Tortonesi, A. Morelli, M. Govoni, J. Michaelis, N. Suri, C. Stefanelli, and S. Russell. Leveraging Internet of Things within the military network environment - Challenges and solutions. *2016 IEEE 3rd World Forum on Internet of Things, WF-IoT 2016*, pages 111–116, 2017. doi: 10.1109/WF-IoT.2016.7845503.
- [73] S. Tsugawa, S. Kato, and K. Aoki. An automated truck platoon for energy saving. In *2011 IEEE/RSJ International Conference on Intelligent Robots and Systems*, pages 4109–4114. IEEE, 9 2011. ISBN 978-1-61284-456-5. doi: 10.1109/IROS.2011.6094549. URL <http://ieeexplore.ieee.org/document/6094549/>.
- [74] Sadayuki Tsugawa, Sabina Jeschke, and Steven E. Shladover. A Review of Truck Platooning Projects for Energy Savings. *IEEE Transactions on Intelligent Vehicles*, 1(1):68–77, 2016. ISSN 2379-8858. doi: 10.1109/tiv.2016.2577499.
- [75] Unknown. <https://land-der-ideen.de/wettbewerbe/deutscher-mobilitaetspreis/preistraeger/best-practice-2019/db-medibus>, 2019. URL <https://land-der-ideen.de/wettbewerbe/deutscher-mobilitaetspreis/preistraeger/best-practice-2019/db-medibus>.
- [76] Ruud van der Ham. Salabim, 2019. URL <https://www.salabim.org/manual/index.html>.

- [77] Hans P.M. Veeke, Jaap A. Ottjes, and Grabriël Lodewijks. *The Delft Systems Approach*. 2008. ISBN 9781848001763. URL <http://weekly.cnbnews.com/news/article.html?no=124000>.
- [78] T.A Wagner. *An Application science for multi-agent systems*. 2004. ISBN 0792372107.
- [79] Ziran wang, Guoyuan Wu, Senior Student Member, Matthew J Barth, Guoyuan Wu, Senior Student Member, and Matthew J Barth. A Review on Cooperative Adaptive Cruise Control (CACC) Systems. *arXiv preprint arXiv:1809.02867*, pages 2884–2891, 2018. URL <https://arxiv.org/ftp/arxiv/papers/1809/1809.02867.pdf>.
- [80] Wei Ren, R.W. Beard, and E.M. Atkins. A survey of consensus problems in multi-agent coordination. In *Proceedings of the 2005, American Control Conference, 2005.*, pages 1859–1864. IEEE, 2005. ISBN 0-7803-9098-9. doi: 10.1109/ACC.2005.1470239. URL <http://ieeexplore.ieee.org/document/1470239/>.
- [81] Allen Wilhite, Laird Burns, Ravi Patnayakuni, and Fan Tseng. Military supply chains and closed-loop systems: Resource allocation and incentives in supply sourcing and supply chain design. *International Journal of Production Research*, 52(7):1926–1939, 2014. ISSN 1366588X. doi: 10.1080/00207543.2013.787173.
- [82] M Wooldridge. *An introduction to multi-agent statistics*. John Wiley & Sons, Ltd., Chichester, 2nd edition, 2002. ISBN 9783642144349. doi: 10.1007/978-3-642-14435-6{_}1.
- [83] Feng Xiao, Long Wang, Jie Chen, and Gao Yanping. Finite-time formation control for second-order multi-agent systems. *Proceedings of the 33rd Chinese Control Conference, CCC 2014*, 45(11):1761–1766, 2009. ISSN 21612927. doi: 10.1109/ChiCC.2014.6896895. URL <http://dx.doi.org/10.1016/j.automatica.2009.07.012>.
- [84] Durk-Jouke Van Der Zee and Jack G A J Van Der Vorst. A modeling framework for supply chain simulation: Opportunities for improved decision making*. *Decision Sciences*, 36(1):65–95, 2005.
- [85] Limin Zhang, Jian Sun, and Tao Cai. Distributed Topology Switching Strategy Designing for Heterogeneous Vehicle Platoons. *IEEE International Conference on Control and Automation, ICCA, 2018-June:734–738*, 2018. ISSN 19483457. doi: 10.1109/ICCA.2018.8444177.

Appendix I

This appendix displays all table values that are extracted from python. These tables contain all KPI values, that have been used to create graphs in sensitivity experiments and load cases.

Table 1 : Table containing mean value of stock levels in the sensitivity analysis

Design	Consumption rate					Link drop-out rate					Node drop-out rate										
1-1-1	2.26	2.18	2.10	2.01	1.92	1.80	2.26	2.23	2.21	2.10	2.11	1.91	2.26	2.11	2.08	2.06	2.04	2.05			
1-3-1	2.26	2.17	2.05	1.95	1.81	1.55	2.26	2.27	2.26	2.24	2.22	2.15	2.26	2.25	2.20	2.12	2.10	2.06			
1-5-1	2.03	1.84	1.68	1.47	1.19	0.97	2.03	2.01	2.03	2.02	1.96	1.92	2.03	2.05	2.05	2.02	2.03	2.06			
1-1-1-P	2.30	2.23	2.15	2.08	2.00	1.89	2.30	2.26	2.22	2.11	2.09	1.94	2.30	2.16	2.14	2.13	2.12	2.12			
1-3-1-P	2.24	2.18	2.09	1.94	1.83	1.51	2.24	2.24	2.26	2.24	2.22	2.14	2.24	2.25	2.22	2.17	2.16	2.13			
1-5-1-P	1.94	1.82	1.56	1.38	1.18	0.99	1.94	1.91	1.94	1.98	2.02	1.86	1.94	2.00	2.00	1.99	2.10	2.04			

Table 2: Table containing median value of stock levels in the sensitivity analysis

Design	Consumption rate				Link drop-out rate				Node drop-out rate									
	2.26	2.18	2.10	2.01	1.92	1.80	2.26	2.24	2.22	2.11	2.13	1.89	2.26	2.11	2.08	2.06	2.06	
1-1-1	2.27	2.18	2.08	1.99	1.82	1.54	2.27	2.27	2.26	2.25	2.24	2.18	2.27	2.25	2.20	2.11	2.09	2.06
1-3-1	2.07	1.85	1.68	1.50	1.24	0.97	2.07	2.04	2.05	2.04	2.01	1.99	2.07	2.07	2.06	2.03	2.06	2.06
1-1-1-P	2.30	2.23	2.15	2.08	1.99	1.90	2.30	2.27	2.23	2.14	2.11	1.93	2.30	2.17	2.15	2.13	2.12	2.13
1-3-1-PT	2.27	2.20	2.12	1.97	1.87	1.49	2.27	2.27	2.27	2.26	2.23	2.16	2.27	2.25	2.22	2.16	2.15	2.14
1-5-1-P	2.03	1.83	1.62	1.43	1.26	1.03	2.03	2.05	2.05	2.03	2.04	1.98	2.03	2.06	2.09	2.03	2.11	2.12

Table 3: Table containing mean values of lead times in the sensitivity analysis

Design	Consumption rate							Link drop-out rate							Node drop-out rate								
1-1-1	242.1	243.1	243.4	244.1	245.9	251.9	242.1	269.8	288.3	415.5	351.5	726.8	242.1	392.6	418.8	439.9	440.2	439.2					
1-3-1	234.2	232.9	235.1	238.4	246.4	271.5	234.2	234.2	241.8	244.3	258.0	317.8	234.2	252.3	300.7	373.5	400.0	422.5					
1-5-1	240.3	257.6	268.1	285.9	300.0	309.5	240.3	243.5	240.4	246.5	264.1	286.7	240.3	250.2	257.7	300.2	348.9	378.9					
1-1-1-P	216.0	211.4	212.7	210.6	212.1	215.4	216.0	248.6	286.5	378.8	341.0	615.5	216.0	338.8	359.2	374.5	375.8	373.4					
1-3-1-P	219.5	216.0	214.9	228.1	227.5	261.2	219.5	222.0	222.2	232.9	248.8	316.7	219.5	237.3	280.4	333.9	347.9	363.8					
1-5-1-P	0.6	241.9	266.0	278.5	294.0	301.7	239.6	245.7	242.3	235.3	239.5	280.1	239.6	239.8	262.5	260.8	312.2	340.1					

Table 4: Table containing median values of lead times in the sensitivity analysis

Design	Consumption rate						Link drop-out rate						Node drop-out rate					
	241.7	243.0	243.2	244.1	245.9	250.0	241.7	266.1	279.6	394.8	343.0	674.7	241.7	392.0	417.3	439.8	439.8	438.8
1-1-1	241.7	243.0	243.2	244.1	245.9	250.0	241.7	266.1	279.6	394.8	343.0	674.7	241.7	392.0	417.3	439.8	439.8	438.8
1-3-1	233.9	232.5	233.1	236.9	244.4	268.7	233.9	233.2	236.3	238.3	252.1	301.7	233.9	250.1	293.3	380.5	402.3	427.8
1-5-1	238.2	254.5	268.7	276.2	293.9	298.4	238.2	240.8	240.3	245.2	257.3	275.6	238.2	249.1	256.5	306.4	352.8	383.9
1-1-1-P	216.1	210.7	213.0	210.6	211.9	214.3	216.1	239.1	283.9	358.2	332.1	621.9	216.1	339.0	357.2	376.1	377.6	373.6
1-3-1-P	217.0	212.8	212.1	219.4	222.1	255.7	217.0	218.7	218.9	228.3	248.0	293.3	217.0	235.6	278.0	342.3	350.2	367.7
1-5-1-P	223.9	240.1	247.1	266.9	274.5	287.9	223.9	222.2	223.4	227.0	234.4	257.5	223.9	232.3	251.6	252.0	316.9	334.0

Table 5: Table containing mean values of order fulfillment in the sensitivity analysis

Design	Consumption rate						Link drop-out rate						Node drop-out rate					
1-1-1	95.0	97.5	96.9	97.2	97.6	97.4	95.0	94.2	93.0	85.4	89.3	57.3	95.0	91.9	91.2	92.2	92.9	92.0
1-3-1	95.9	97.6	97.1	97.6	96.4	95.2	95.9	96.1	95.8	95.5	94.6	88.3	95.9	94.9	92.6	91.6	91.9	90.6
1-5-1	96.3	95.9	95.3	95.6	94.9	94.1	96.3	95.9	95.8	95.8	95.3	93.7	96.3	94.8	95.0	95.5	95.0	94.1
1-1-1-PLAT	96.3	97.5	97.3	97.4	98.2	98.1	96.3	94.9	92.3	83.8	88.6	64.1	96.3	93.3	93.3	92.6	93.3	93.7
1-3-1-PLAT	95.8	96.7	96.9	96.4	96.2	94.8	95.8	96.1	96.8	94.4	95.1	88.9	95.8	95.4	93.3	92.1	93.1	91.1
1-5-1-PLAT	95.5	95.0	94.9	95.3	94.7	93.0	95.5	95.5	95.7	94.5	94.5	93.0	95.5	93.7	94.1	93.9	93.9	93.2

Table 6: Table containing median values of order fulfillment in the sensitivity analysis

Design	Consumption rate					Link drop-out rate					Node drop-out rate							
	93.8	98.7	97.9	97.7	98.3	97.3	93.8	95.7	92.3	87.1	90.8	60.3	93.8	91.2	91.1	91.7	92.3	91.0
1-1-1	97.2	98.2	97.7	98.1	96.5	95.6	97.2	97.0	97.3	96.4	95.7	88.6	97.2	95.0	91.4	90.6	90.9	90.1
1-3-1	97.2	96.2	95.2	95.8	95.1	94.9	97.2	96.9	96.5	96.1	95.8	94.7	97.2	96.3	95.6	97.4	96.6	96.6
1-5-1	97.5	98.4	98.1	98.5	98.6	98.5	97.5	96.3	94.3	88.2	89.8	66.4	97.5	94.4	93.2	92.5	94.1	94.3
1-1-1-PLAT	96.2	97.7	97.8	97.3	96.7	95.9	96.2	97.1	97.1	94.8	96.2	91.5	96.2	95.8	93.1	91.2	93.6	91.1
1-3-1-PLAT	96.1	96.1	95.9	96.5	95.9	93.8	96.1	96.1	96.1	95.3	95.6	93.6	96.1	95.4	96.0	95.3	95.8	94.5

Table 7: Table containing all median values of lead time during load case experimenting.

Load case	1 Unit					2 Units					3 Units				
LC1	9.6	5.8	4.5	4.3	4.5	9.4	5.9	4.8	4.5	4.5	9.2	5.8	4.9	4.6	4.4
LC2	10.3	7.8	5.5	5.0	4.9	11.0	7.4	5.7	5.2	5.1	11.3	7.4	5.6	5.2	4.9
LC3	15.3	10.4	8.2	7.2	6.4	13.2	10.0	8.0	6.9	6.3	11.5	9.4	7.6	6.8	6.1

Table 8: Table containing all median values of supply stock levels during load case experimenting.

Load case	1 Unit			2 Units			3 Units		
	2.0	2.1	2.2	2.1	2.1	2.2	2.0	2.2	2.2
LC1	2.0	2.1	2.2	2.1	2.1	2.2	2.0	2.2	2.2
LC2	1.6	1.8	2.0	2.0	1.9	2.1	1.7	2.1	2.1
LC3	1.5	1.5	1.7	1.7	1.6	1.8	1.5	1.6	1.9

Table 9: Table containing all median values of order fulfillment levels during load case experimenting.

Load case	1 Unit						2 Units						3 Units					
	LC1	81.2	97.8	99.5	99.5	99.0	83.7	99.4	99.7	99.5	99.7	85.5	98.9	99.8	99.6	99.7		
LC2	81.6	90.5	98.6	99.2	99.0	77.9	95.1	98.6	98.9	99.1	77.0	94.6	98.6	99.2	99.4			
LC3	64.4	78.5	87.8	93.3	96.5	67.8	81.1	89.5	95.0	96.2	73.3	85.3	92.7	95.9	96.9			