

## Design of a Micro-Propulsion Subsystem for a PocketQube

Uludag, Sevket; Pallichadath, Vidhya; Speretta, Stefano; Radu, Silvana; Chronas Foteinakis, Nikitas; Melaika, Antanas; Cervone, Angelo; Gill, Eberhard

### Publication date

2019

### Document Version

Final published version

### Published in

Proceedings of the International Symposium on Space Technology and Science, Fukui (Japan), June 15th-21st, 2019

### Citation (APA)

Uludag, S., Pallichadath, V., Speretta, S., Radu, S., Chronas Foteinakis, N., Melaika, A., Cervone, A., & Gill, E. (2019). Design of a Micro-Propulsion Subsystem for a PocketQube. In *Proceedings of the International Symposium on Space Technology and Science, Fukui (Japan), June 15th-21st, 2019* Article 2019-f-50

### Important note

To cite this publication, please use the final published version (if applicable).  
Please check the document version above.

### Copyright

Other than for strictly personal use, it is not permitted to download, forward or distribute the text or part of it, without the consent of the author(s) and/or copyright holder(s), unless the work is under an open content license such as Creative Commons.

### Takedown policy

Please contact us and provide details if you believe this document breaches copyrights.  
We will remove access to the work immediately and investigate your claim.

# Design of a Micro-Propulsion Subsystem for a PocketQube

By Mehmet Sevket ULUDAG,<sup>1)</sup> Vidhya PALLICHADATH,<sup>1)</sup> Stefano SPERETTA,<sup>1)</sup> Silvana RADU,<sup>1)</sup> Nikitas CHRONAS-FOTEINAKIS,<sup>1)</sup> Antanas MELAIKA,<sup>1)</sup> Angelo CERVONE,<sup>1)</sup> and Eberhard GILL<sup>1)</sup>

<sup>1)</sup>Delft University of Technology, Delft, The Netherlands

This paper gives an insight on different sub topics related to a micro-propulsion subsystem for a PocketQube. First, PocketQubes will be introduced and then Delfi-PQ will be presented, providing an overview of the mission for which this micro-propulsion system will be used. Step by step, the paper will explain the subsystem, its challenges, mechanical aspects, electronics aspects and future work. In the long term, these miniaturized micro-propulsion systems might play an important role for micro satellites for attitude control, low-altitude orbital maintenance, formation flying, orbital transfer and several other potential applications.

**Key Words:** PocketQube, Micro-Propulsion, Resistojet, VLM, LPM

## 1. Introduction

Miniaturization within the space field during the past year has been possible due to the strict standardization. A great example of standardized miniaturization that emerged into an expansive business is the well known CubeSat. CubeSats represent satellites of roughly 100x100x100 mm size and they can be joined into multiple combinations of cubes, building a bigger satellite if needed. The Delft University of Technology was one of the pioneers in designing, developing, manufacturing and launching a 3U CubeSat called Delfi-C3. However, due to its standardization and afferent massive use in the industry, we oriented towards a new miniaturized version of the CubeSats, the PocketQube. This type of satellite represents a platform of approximately 50x50x50 mm per unit and, at the time the Phase A of Delfi-PQ (Fig. 1) was started, no standardization of this form factor existed. In the meantime, The Delft University of Technology along with other partners from the PocketQube community, published a first revision of the PocketQube Standard.<sup>1)</sup> Because Delfi-PQ represents the first PocketQube developed in Delft, the aim is to set a standard for this type of satellite and qualify its structure as well as validating in flight the designed and developed core bus.

The long-term goal of Delfi-PQ is to develop a core platform which secures basic functionalities and shall iteratively evolve over time. Given the fact that the development happens in a university, it is desired that as many students as possible work on the satellite. As the previous missions from the group, missions had a clear objective for education, technology demonstration and innovation.

## 2. Pocketqube standard

The idea of this new form factor was first presented and proposed in 2009 by Prof. Robert J. Twiggs in collaboration with Morehead State University (MSU) and Kentucky Space. As first showcased, the so called PocketQube represents a cube-shaped platform of 50x50 mm with an approximated mass of 250 g. The first launched PocketQube was through the UniSat5 mission.<sup>2,3)</sup>

The first revision of the standard published in July 2018 com-



Fig. 1. Assembled 3 unit(3P) Delfi-PQ.

prises the harmonisation in dimensions between the main players within the PocketQube Community: Delft University of Technology, Alba Orbital and Gauss Srl. The aim of the published document is to converge towards common numbers and interfaces for a PocketQube platform.

## 3. Mission Description

The overall goal of Delfi-PQ is based on the previous Delfi satellite projects. The Delfi program (until now, consisting of CubeSats developed within the university) had clear objectives for education, technology demonstration and innovation. The goal with respect to PocketQubes is developing a baseline that will be demonstrated in orbit. After the in-orbit demonstration, advancements to the satellite platform will be made in an iterative manner having as primary goal the finding of innovative payloads and applications that can make the platform sus-

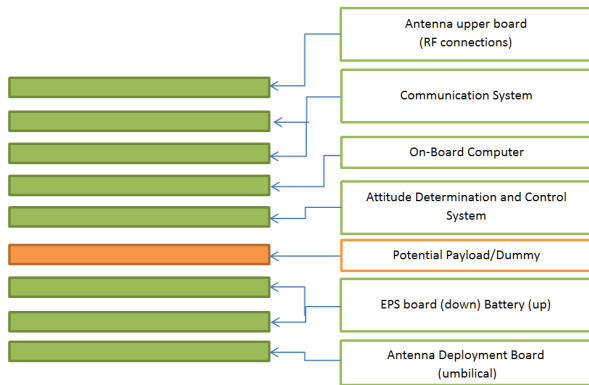

Fig. 2. Delfi-PQ subsystems.

tainable. Technology demonstration of subsystems is foreseen starting with the following iterations of the satellite, such as micro-propulsion,<sup>4)</sup> thermal payloads, lens-less cameras, etc. The long term goal of the PocketQubes program is building 3P PocketQubes and fitting the core bus in 1P, both micro-propulsion and ADCS in 1P and an innovative payload within the remaining 1P.

The Delfi program mission objectives align with the development of the first PocketQube of TU Delft through the following main directions:

1. Education: As a university, one of the main goals is to pass know-how to students in space engineering field.
2. Technology demonstration: Several payloads that need in orbit demonstration are foreseen at the moment for Delfi-PQ and/or its successor: The micro-propulsion team is developing a dual thruster system based on: VML (Vaporizing Liquid Micro-resistojet) and LPM (Low-Pressure Micro-resistojet).<sup>4)</sup> Other teams are working on a GPS payload, on radio experiments, an optical reflector and a radar calibration experiment as future applications.
3. Innovation: A PocketQubes is 8 times smaller in volume when compared to a CubeSat, a constellation of PocketQubes launched at once can enable interesting applications (such as optical reflectors, radio and radar experiments) provided there is a frequent launch available. At the moment, Alba Orbital is developing a 96P deployer<sup>5)</sup> that is meant to have the footprint of a 12U CubeSat deployer but instead it can place in orbit a very large amount of PocketQubes.

The goal of the first launch of Delfi-PQ is to demonstrate a reliable core bus platform that can fit in 1P and to test the overall integrity of the designed structure. The subsystems of Delfi-PQ are shown in Fig.2

#### 4. Micro-Propulsion Subsystem

The micro-propulsion demonstration payload consists of dual thrusters including both VLM and LPM, a common propellant tank, feed system, and other supporting control electronics. The aim of the system is to test the two different micro-resistojet technologies: one based on vaporization of slightly pressurized liquid water (VLM Vaporizing Liquid Micro-resistojet) and one based on the free molecular acceleration of propellant molecules stored at very low pressure (LPM Low-Pressure

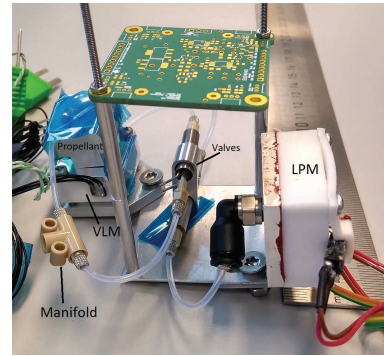

Fig. 3. Assembly of the prototype completed in the cleanroom; pressure sensors and wiring are not attached.

Micro-resistojet).

Some of the main requirements that were set for this demonstration payload are thrust level between 0.1 to 3 mN and a specific impulse from 50 to 100s. The required technology demonstrator should fit within the volume budget of 42 mm x 42 mm x 30 mm. A preliminary table top assembly can be seen in Fig. 3. The main characteristics of the micro-resistojet are a high thrust-to-power ratio, low system specific mass and the possibility to use almost any type of fluid as a propellant. The latest developments, testing, and results carried by the research group on MEMS-based Vaporizing Liquid Micro-resistojet (VLM) and the Low-Pressure Micro-resistojet (LPM) design concepts for CubeSats have been presented in.<sup>6-13)</sup> Also, the complete design of the corresponding micro-propulsion system including while a system engineering challenges, description and development plan of the micro-propulsion payload for Delfi-PQ preliminary design, fabrication and test results for the picosatellites are presented in.<sup>4,14)</sup>

The block diagram of the system is shown in Fig. 4. An initial mass estimate for the demonstrator, based on the real hardware for two thrusters, micro-valve, feed system, and supporting electronic board is shown in Table 1. Mass can be further optimized by introducing a MEMS valve and by optimizing the mechanical interface including the channels and connections. The payload has common propellant storage for the two thrusters, based on the use of the capillarity properties of water in small diameter tubes and two separate MEMS chips with their own dedicated valves (for heating and accelerating the propellant). The storage tubing which is shared between the VLM and LPM is filled with water, pressurized by gaseous nitrogen. During the testing, the first mode to be initiated is the VLM testing (VLM valve open, LPM valve closed). As the water propellant gets depleted due to the VLM firing, the nitrogen gas has more available volume in the storage tubing and the pressure decreases. When the pressure has dropped sufficiently, the VLM valve is closed and the LPM testing mode is initiated. A description of the requirements and design of the complete micro-propulsion demonstrator, as well as its expected operational envelope for in-orbit functional testing, is provided in.<sup>15)</sup>

#### 4.1. Challenges

In addition to PocketQube dimensions, there are many additional challenges due to the requirements of the micro-propulsion subsystem. These challenges can be divided in two main groups. One of them is mechanical aspects and the other

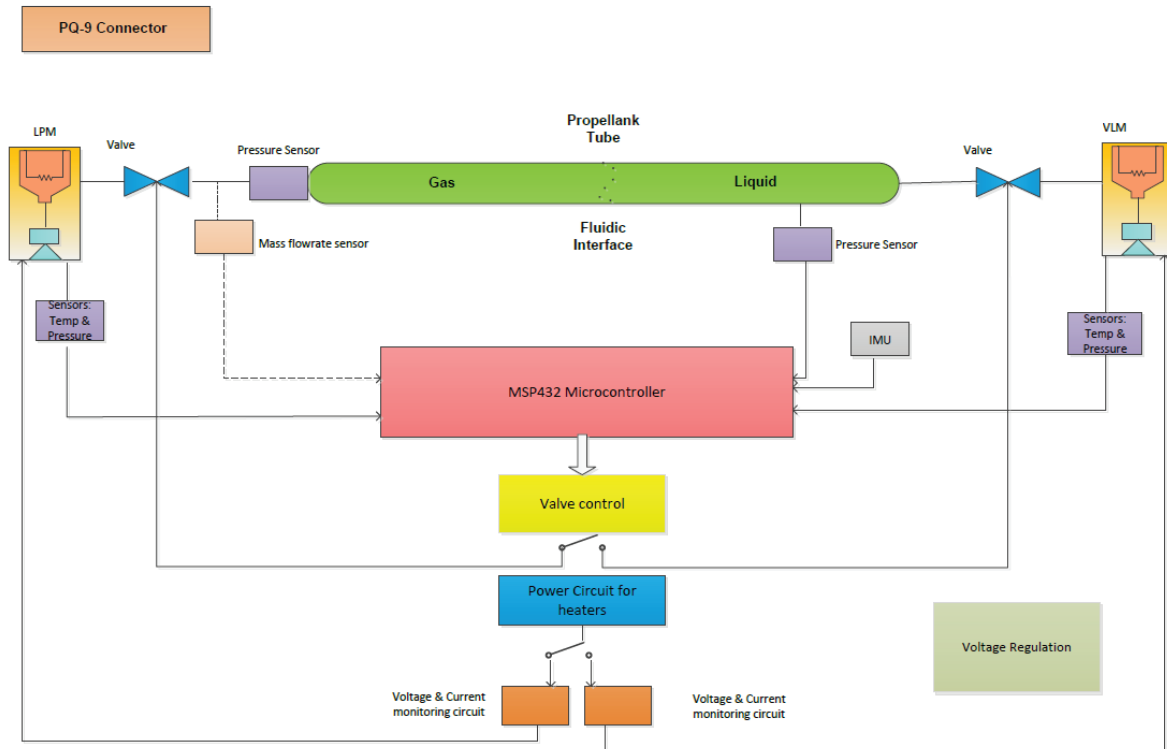

Fig. 4. Block diagram of the micro-propulsion system.

one is electronics aspects.

First problem is due to multiple thruster being baselined. As stated in the previous section, the subsystem will have two different thruster elements, where both of them will be tested and validated individually. Fitting multiple thrusters, valves and other mechanical parts in a confined volume (approximately  $50\text{cm}^2$ ) is an obvious challenge. Besides the internal limitation, there are external factors which effect the design of both the satellite and the subsystem. In order to fill the tank, there should be an access point for the subsystem without disassembling the satellite. Also there has to be two additional open surfaces to be able to place the thrusters for exit planes. Lack of a complete mechanical structure inside the satellite causes integration and assembly problems which will be explained in the next section.

Second aspect is electronics. Electronics can only be on both sides of a  $42 \times 42$  mm PCB with the height limit of 2mm on the bottom side and 4mm on the top side of PCB (Fig. 8). Besides this mechanical limitation, the system requires multiple supply voltages and multiple dedicated sensors for validating the subsystem which will be explained in Section 6.

### 5. Mechanical Design

First of all, most of the problems are caused by the small volume also containing two different systems in the same volume using a single configuration. The micro-propulsion subsystem consists of 7 main elements: electronics, 2 solenoid valves, 2 MEMs thrusters (VLM and LPM), check valve and cage (please refer to Fig. 5 for further details). These elements need to fit in a  $42 \times 42 \times 30$  mm volume and the reason behind this is that a 1

unit PocketQube (1P) is approximately  $50 \times 50 \times 50$  mm and, beside the micro-propulsion unit, spare volume is required for the core subsystems, such as communication and power.

Instead of using a propellant tank, coiled tubes are going to be used as the tank itself. This allows the system to be more flexible, able to accommodate different shapes by bending the tubes with proper bending radius. The other challenge is the size of the safety screens. These are filters like tubing adapters, which

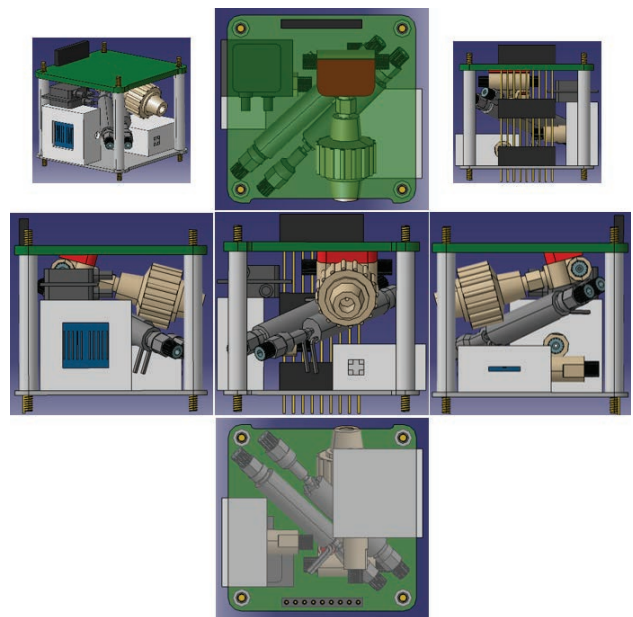

Fig. 5. CAD drawing of the micro-propulsion subsystem without its cage from different angles; (starting from top left): orthogonal, top, back, left, front, right and bottom view.

have 12 micron mesh inside and allow proper connections of the elements via tubing. In Fig. 5, it can be seen that two parallel valves are suspended in diagonal position due to their length and to allow a sufficient bending radius for the tubes. Thrusters are placed on the edge to minimize the distance between the nozzle and the solar panel cut out. In addition to these, thrusters are placed close to one edge of the solar panels which allows them to rotate the satellite, thus, enabling the usage of the gyros as sensors in case the accelerometer are be able to achieve the required precision. Gyroscopes can easily measure the angular acceleration, thus, providing extra data for validation (further details are given in Section 6.). When the whole subsystem is assembled, everything will be in a cage in order to shield other subsystems from any possible leakage. The cage and its placement can be seen in Fig 6. The first prototype of the cage is 3D printed to do a fit check and to verify the integration with the rest of the satellite (Fig. 7).

In addition to its internal integration, the micro-propulsion subsystem forced the structure of the satellite to be changed. In Figure 1 it can be seen that, in the middle of the solar panel, there is a cut out which is at its maximum dimensions to save area for the solar cells; there is a metal structure (grey in in Fig. 1) for the placement of the thrusters on the structure of the satellite. This metal structure was designed to allow the solar panels to be connected mechanically to each other and to provide structural integrity to the satellite. The same metal piece in its current design is clashing with the thrusters and this needs to be solved with a custom solution. This problem was solved by designing the cage to be also used as the structural part for the whole satellite. In Figure 6 and 7, it can be seen that the cage is used a structural part and its fit check has been verified. Elements of the subsystem will be assembled on the support frame, then it will be placed inside the cage and, as the last step, the PCB (which also acts as a lid) will be placed on to the cage. During the final assembly of the subsystem, the PCB will be glued to the cage to provide extra protection against any possible leakage.

Table 1 shows the mass budget of the subsystem. Structural components include the propulsion system cage (the red 3D

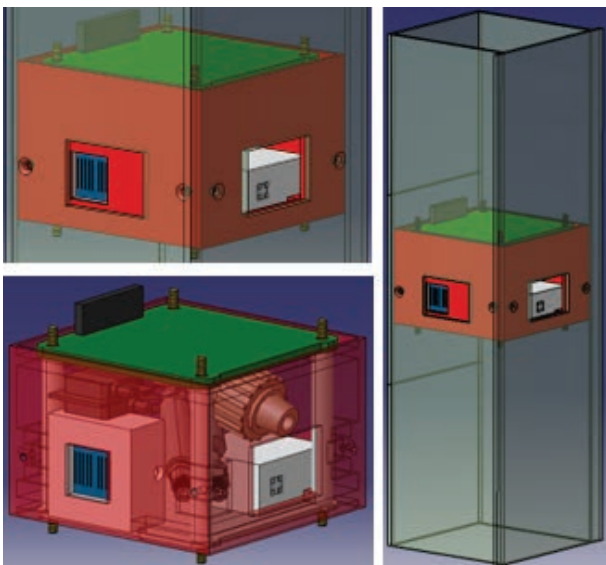

Fig. 6. CAD drawing of the micro-propulsion subsystem.

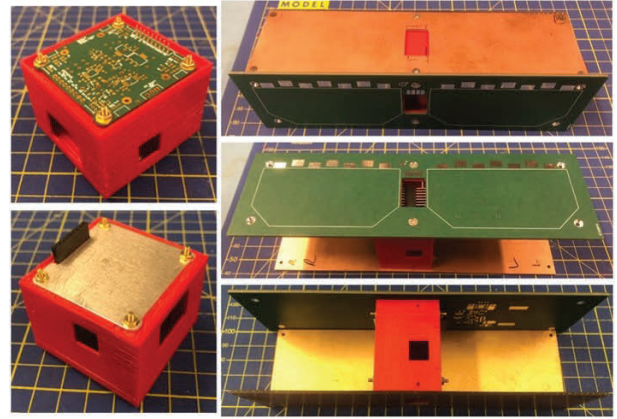

Fig. 7. Integrated micro-propulsion subsystem dummy.

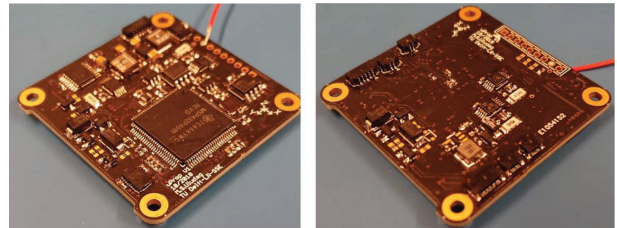

Fig. 8. PCB of the Micro-Propulsion subsystem. Bottom side on the left, top side on the right.

printed box, which will be produced from aluminum for the actual application), M2 torque screws, Aluminum base plate, thruster interface brackets, Aluminum valve support structure and Aluminum propellant tube container. Electrical components include sensors, PCB, electronics, and wiring. Propulsion components include VLM thruster interface (the green 3D printed box), LPM thruster interface (which will be produced from ceramic material), solenoid valves, tubes, 3-boss manifold, check valve, propellant, male-male adapter, and safety screens.

## 6. Electronic Design

Figure 8 shows the electronics of the micro-propulsion subsystem (bottom PCB side on the left and top side on the right). To reduce the development time for the second version and to validate the bare minimum functionalities, additional sensors and an SD card were not placed. As a result of this, the top side of the PCB is currently empty for future improvements.

The subsystem will receive its power from one of the PQ-9 voltage bus lines.<sup>19-21)</sup> The peak instantaneous power consumption for the bus line is limited to 4.5 W. Another value to consider is that the bus voltage will be unregulated and will vary between 3-4.2 V.<sup>16)</sup> There are two separate solenoid valves to control each thruster which requires 24 V to open and 3.3 V to keep

Table 1. Estimated mass budget.

Component	Estimated Mass[g]	Measured Mass[g]
Structural	36	23.283
Electrical	20	14.524
Propulsion	28.6	17.015
10% Contingency	6.4	6.400
Total	84.6	61.222

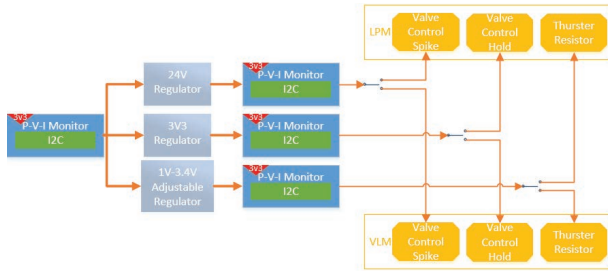

Fig. 9. Power distribution diagram.

it open. As the thrusters itself, they require a varying power supply with respect to pressure of the propellant tank, varying between 1-3.5 V. The overall system requires at least 3 different voltage values. In order to validate the propulsion payload demonstrator there are 2 IMUs (inertial measurement unit), 4 pressure sensors, 3 temperature sensors, 4 voltage-current monitors.

### 6.1. Power supply and power management

Power received from the bus will be going through the main V-I Monitor, so that the overall power consumption of the subsystem can be monitored. Figure 9 shows how the power lines are then split to power the different component groups. The power consumption during the hold and open phases are monitored with different V-I monitors. The fourth monitor is used to measure the power consumption of resisto-jets. Due to the limited space on the PCB, the same measurement lines are being used for both of the systems (VLM and LPM). Power is routed via 6 individual MOSFETs switches: at the output of each V-I monitor, there are multiple switches as seen in Fig 9 (S1, S2 and S3). These switches are used to control the thrusters. When the subsystem is turned on, all the power supplies will be active but the thrusters have to be controlled individually for safety reasons.

### 6.2. Thrusters Selection and control

Each thruster has its own control circuitry which in the end is controlled via 3 signals. The first signal is used to initiate the resisto-jets (heaters) by enabling the low-side switches of the resisto-jet. After the initial heating, the second signal which controls the spike (opening) of the valve, is triggered. This signal enables both LPM\_CTRL\_1 and LPM\_CTRL\_2 which can be seen in Fig 10. LPM\_CTRL\_1 is related to valve spike and hold, and LPM\_CTRL\_2 is related to valve spike only which is shown in Fig. 11. This signal needs to be active for at least 0.35 ms to open the valve. When the valve is opened, the third signal is triggered to keep the valve open, disabling the LPM\_CTRL\_2 while keeping the LPM\_CTRL\_1 enabled. Both the thrusters have individual control switches to enable them one at a time. Software prevents both thrusters working at the same time even if the wrong command is received. In addition to the heater initiation signal, there is a control algorithm which is currently in development phase, to change the supply voltage level of the resisto-jet to adapt to the changes in pressure (which influences also the mass flow rate). Since the heating chamber size is fixed, the amount of power needs to be varied according to mass flow rate to keep temperature at the required level.

Figure 11 shows control sequence to activate the valves and the timeline for the activation of the different signals. The

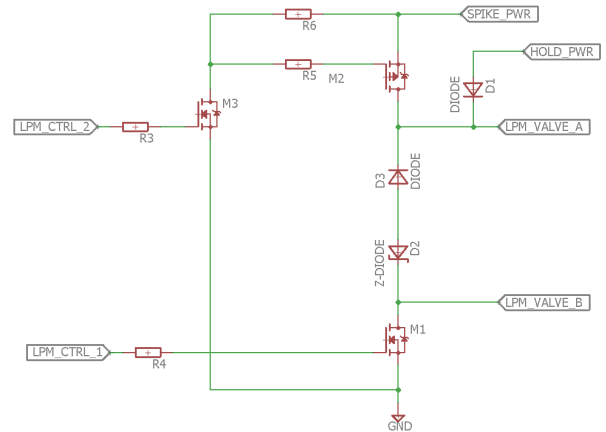

Fig. 10. Valve control circuitry.

graphs are not in scale, they are made in different levels for visual clarity. The heater initiation at step 1 is used to optimize fuel consumption. When the subsystem is on, it will repeat the steps 2, 3 and 4 with respect to the required activation frequency to achieve a controlled thrust. Currently, the planned frequency is between 250 and 500 Hz. The resistor power consumption is used in Figure to show on or off states (D stands for Disabled and E stands for Enabled). If one of the thrusters is in use, a software protection keeps the other one off. In case of a failure, the electrical power system has a power protection to limit the power consumption to 4.5 W or 1.5 A. Power protection and current protection is made via software and additionally current is limited on the switches located on the power system board.<sup>16)</sup>

### 6.3. Sensors for validation

To validate the subsystem in space, multiple sensors have been placed. Figure 4 shows two of the pressure sensors placed on the LPM side, with one of the sensors having the capability to measure the temperature too. The same set of sensors is placed on the VLM side, too, but at different locations. Due to the limited communication lines, a limited amount of sensors can be connected to MCU directly. Each set of sensors is connected to different communication lines in order to prevent data clash and to simplify the overall design. In addition to the pressure and temperature sensors, there are 2 IMUs (BMX055). This is capable of sensing down to an acceleration of  $0.0096m/s^2$  and an angular velocity of  $0.004^\circ/s$ .<sup>17)</sup> With respect to minimum thrust level requirement of 0.12mN and a

Sequence	Step 0	Step 1	Step 2	Step 3	Step 4	Step 5-0
Valve Spike	D	D	E	D	D	D
Valve Hold	D	D	E	E	D	D
Heater (Resistor)	D	E	E	E	E	D
EVENT	System is off	Heater standby	Open Valve	Keep Valve	Valve Off, Ventilation	System is Off
24V Valve Spike						
3V3 Valve Hold						
Resistor Power						
Duration		TBD	Min 0.35ms	TBD	TBD	

Fig. 11. Control sequence.

Table 2. Figures with respect to electronics of the mirco-propulsion system.

Items	Mass	Cost of 1	Cost of 5
PCB	7 gr	100 €	150 €
Electronics	3.2 gr	144 €	526 €
Total	10.2 gr	244 €	678 €

total mass of 0.5 kg and dimensions of 50x50x178 mm, the minimum acceleration and angular velocity increment are respectively  $0.0024 \text{ m/s}^2$  and  $0.055 \text{ }^\circ/\text{s}^{14,18}$  (measurement noise not considered). As a result, the BMX055 would be good to measure the angular velocity change but is not capable of measuring the minimum acceleration.

#### 6.4. Electronics production costs

This section is to provide information and basic data related to the electronics of the subsystem. Table 2 shows the mass and material cost for the PCB. The connector which is used for the bus connection is not included. PCB costs are given for 7 days delivery from manufacturer data. Electronics cost changes a lot due to minimum order quantity of some of the components. These values have been presented in order to give more insights into the the system and to give an idea of the production cost for the system.

#### 7. Software & Interface of the Subsystem

The onboard software runs on the MSP432 micro-controller with the TI-RTOS real-time operating system. The software consists of 2 parts: the first one is generic and used on all other subsystems in the satellite, while the second is specific for the micro-propulsion subsystem. The subsystem specific code includes the propulsion control code and the interfaces with the sensors.

Commands and telemetry are issued through the interface and the PQ9 bus<sup>22</sup>) when the subsystem is used in the satellite. It can also be used as a standalone system, with commands and telemetry sent through the UART found in the programming connector of the subsystem.

There are 3 tasks running on the system. The main task performs system initialisation and updates sensor values in a user-defined interval. When a new command is received, the 2<sup>nd</sup> task processes and executes it. The 3<sup>rd</sup> task is used only when the system is used as standalone or when testing and provides the standalone command interface and extra debugging functionality when needed.

The system is accessed through the command interface and the following commands are available:

1. Retrieve the system parameters using the housekeeping data
2. Controls the heaters
3. Starting propulsion: the user selects the VLM or LPM valve and the duration that the system will be active. Before accepting the command, the software checks that propulsion is not already active or not and that duration is in a normal preset range.

#### 8. Conclusion

This paper presented a micro-propulsion subsystem for PocketQubes including electrical and mechanical challenges, mechanical design, electronics design and the integration of the system in the satellite. It has been shown that the subsystem is feasible even with all the challenges presented.

As a next step, a table top model will be integrated with all mechanical and electrical components. Currently these systems have been tested separately via different test setups due to limited time and man power and also to allow the different aspects of the system to be developed simultaneously.

#### Acknowledgments

The authors want to acknowledge Leon Turmaine, Ackaert Gillies and Barry Zandbergen for their contribution to this project.

#### References

- 1) Radu, S., Uludag, M. S., Speretta, S., Bouwmeester, J., Menicucci, A., Cervone, A., Dunn, A., Walkinshaw, T., Kaled Da Cas, P. L., Capelletti, C., and Graziani, F.: PocketQube Mechanical Interface Standard, <https://dataverse.nl/api/access/datafile/11680>, (accessed April 5, 2019).
- 2) Capelletti, C., Battistini, S., Graziani, F.: Small Launch Platforms for Micro-Satellites, *Advances in Space Research*, **62** (2018), pp. 3298–3304.
- 3) Capelletti, C.: Femto, Pico, Nano: Overview of New Satellite Standards and Applications, 4th IAA Conference on University Satellite Missions and Cubesat Workshop, Rome, Italy, IAA-AAS-CU-17-07-01, 2017.
- 4) Pallichadath, V., de Athayde Costa e Silva, M., Guerrieri, D. C., Uludag, M. S., Zandbergen, B. and Cervone, A.: In-orbit Micro-propulsion Demonstrator for Pico-satellite Applications, 69th International Astronautical Congress, Bremen, Germany, IAC-18,C4,8-B4.5A.6,x44909, 2018.
- 5) AlbaOrbital Deployers, 2019, <http://www.albaorbital.com/deployers/>, (accessed April 10th, 2019).
- 6) Guerrieri, D. C., Cervone, A. and Gill, E.: Analysis of Non-Isothermal Rarefied Gas Flow in Diverging Microchannels for Low Pressure Micro-Resistojets, *ASME Journal of Heat Transfer*, **138** (2016).
- 7) Guerrieri, D. C., de Athayde Costa e Silva, M., van Zeijl, H., Cervone, A. and Gill, E.: Fabrication and Characterization of Low-Pressure Micro-Resistojets with Integrated Heater and Temperature Measurement, *Journal of Micromechanics and Microengineering*, **27** (2017).
- 8) de Athayde Costa e Silva, M., Guerrieri, D. C., van Zeijl, H., Cervone, A. and Gill, E.: Vaporizing Liquid Microthrusters with Integrated Heaters and Temperature Measurement, *Sensors & Actuators: A. Physical*, **265** (2017), pp. 261–274.
- 9) de Athayde Costa e Silva, M., Silvestrini, S., Guerrieri, D. C., Cervone, A. and Gill, E.: A Comprehensive Model for Control of Vaporizing Liquid Microthrusters, *IEEE Transactions on Control Systems Technology*, (2018).
- 10) Silvestrini, S., de Athayde Costa e Silva, M. and Cervone, A.: Closed-Loop Thrust Control for Micropropulsion Systems, 68th International Astronautical Congress, Adelaide, Australia, IAC-17,C4,IP,14,x39001, 2017.
- 11) Pallichadath, V., Silvestrini, S., de Athayde Costa e Silva, M., Maxence, D., Guerrieri, D. C., Mestry, S., Perez Soriano, T., Bacaro, M., van Zeijl, H., Zandbergen, B. and Cervone, A.: MEMS Based Micro-Propulsion System for CubeSats and PocketQubes, 68th International Astronautical Congress, Adelaide, Australia, IAC-17,C4,8-B4.5A.4,x38791, 2017.
- 12) de Athayde Costa e Silva, M., Guerrieri, D. C., Cervone, A. and Gill,

- E.: A Review of MEMS Micropropulsion Technologies for CubeSats and PocketQubes, *Acta Astronautica*, **143** (2018), pp. 234–243.
- 13) Guerrieri, D. C., de Athayde Costa e Silva, M., Cervone, A. and Gill, E.: Selection and Characterization of Green Propellants for Micro-Resistojets, *ASME Journal of Heat Transfer*, **139** (2017).
  - 14) Pallichadath, V., Radu, S., de Athayde Costa e Silva, M., Guerrieri, D. C. and Cervone, A.: Integration and Miniaturization Challenges in the Design of Micro-Propulsion Systems for Picosatellite Platforms, ESA Space Propulsion Conference, Seville, Spain, SP2018\_00163, 2018.
  - 15) Turmaine, L.: A review on current micro-propulsion systems and the design of a micro-resistojet for the PocketQube platform, Literature Study, Delft University of Technology, 2017.
  - 16) Uludag, M. S., Speretta, S., Bouwmeester, J., Gill, E., and Perez Soriano, T.: A New Electrical Power System Architecture for DELFI-PQ, 4th IAA Conference on University Satellite Missions and Cubesat Workshop, Rome, Italy, IAA-AAS-CU-17-07-03, 2017.
  - 17) BOSCH: BMX055 Datasheet, [https://ae-bst.resource.bosch.com/media/\\_tech/media/datasheets/BST-BMX055-DS000.pdf](https://ae-bst.resource.bosch.com/media/_tech/media/datasheets/BST-BMX055-DS000.pdf)(accessed April 8, 2019).
  - 18) Gilles, A.: Verification of micro-propulsion systems:Review and application to Delfi-PQ demonstration payload, Literature Study, Delft University of Technology, 2019.
  - 19) Bouwmeester, J., Gill, E., Speretta, S. and Uludag, S.: A New Approach on the Physical Architecture of CubeSats & PocketQubes, *JBIS.*, **71** (2018), pp. 239–249.
  - 20) Bouwmeester, J., Radu, S., Uludag S., Chronas Foteinakis, N., Speretta, S., Menicucci, A. and Gill, E.: Conditions and Potential Applications for PocketQubes, Small Satellites, System & Services Symposium, Sorrento, Italy, 4S 2018.
  - 21) Speretta, S., Prez Soriano, T., Bouwmeester, J., Carvajal Godnez, J., Menicucci, A., Watts, T., Sundaramoorthy, P., Guo, J. and Gill, E.: CubeSats to PocketQubes: Opportunities and challenges, 67th International Astronautical Congress, Adelaide, Australia, IAC 2016.
  - 22) Bouwmeester, J.: PQ9 and CS14 Electrical and Mechanical Subsystem Interface Standard for PocketQubes and CubeSats, <https://dataverse.nl/dataset.xhtml?persistentId=hdl:10411/3V8RUF>, (accessed April 12, 2019).