

## Liability Factors and Conceptual Framework for Contracts to Manage Design for Digital Fabrication in Construction Projects

Ng, Ming Shan; Hall, Daniel Mark; Hsieh, Shang Hsien

**DOI**

[10.1061/\(ASCE\)LA.1943-4170.0000578](https://doi.org/10.1061/(ASCE)LA.1943-4170.0000578)

**Publication date**

2023

**Document Version**

Final published version

**Published in**

Journal of Legal Affairs and Dispute Resolution in Engineering and Construction

**Citation (APA)**

Ng, M. S., Hall, D. M., & Hsieh, S. H. (2023). Liability Factors and Conceptual Framework for Contracts to Manage Design for Digital Fabrication in Construction Projects. *Journal of Legal Affairs and Dispute Resolution in Engineering and Construction*, 15(1), Article 04522043. [https://doi.org/10.1061/\(ASCE\)LA.1943-4170.0000578](https://doi.org/10.1061/(ASCE)LA.1943-4170.0000578)

**Important note**

To cite this publication, please use the final published version (if applicable). Please check the document version above.

**Copyright**

Other than for strictly personal use, it is not permitted to download, forward or distribute the text or part of it, without the consent of the author(s) and/or copyright holder(s), unless the work is under an open content license such as Creative Commons.

**Takedown policy**

Please contact us and provide details if you believe this document breaches copyrights. We will remove access to the work immediately and investigate your claim.

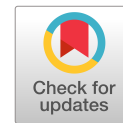

# Liability Factors and Conceptual Framework for Contracts to Manage Design for Digital Fabrication in Construction Projects

Ming Shan Ng, D.Sc., M.ASCE<sup>1</sup>; Daniel Mark Hall, Ph.D., M.ASCE<sup>2</sup>;  
and Shang-Hsien Hsieh, Ph.D., M.ASCE<sup>3</sup>

**Abstract:** The adoption of digital fabrication—fabrication based on digital design—in the early design phase in projects requires a thorough understanding of the liability factors to design the contract. This paper addresses this issue using a two-stage research approach. First, a case study research maps the process from digital design to digital fabrication in an existing project that adopted digital fabrication using the design-bid-build model. Second, a three-round Delphi survey of 14 stakeholders of that project identifies and ranks 163 liability factors under eight categories: actors, resources, conditions, attributes, processes, artifacts, values, and risks. The resources of *management capability* and *building information modeling (BIM) expertise* rank as the two most important liability factors. Building on these findings, the paper presents a conceptual framework for contract design and discusses how the existing project delivery models—design-bid-build, construction management, design-build, and integrated project delivery (IPD)—can consider the liability factors in contracts. DOI: [10.1061/\(ASCE\)LA.1943-4170.0000578](https://doi.org/10.1061/(ASCE)LA.1943-4170.0000578). This work is made available under the terms of the Creative Commons Attribution 4.0 International license, <https://creativecommons.org/licenses/by/4.0/>.

## Introduction

There are many current attempts in the architecture, engineering, and construction (AEC) industry to transform the design and construction process. Conventional construction methods often suffer from design misalignments, poor quality of construction work, and schedule delays. This can incur extra costs due to project schedule overruns or claims and disputes among project parties (Caine and Thomas 2013). Digitalization has been slowly adopted in projects in the industry to improve the process. Among various approaches to adopting digitalization, one is the use of digital fabrication technologies (Bock and Linner 2015). Digital fabrication refers to data-driven production directly based on digital design information and operated by digitally controlled machines. Hence, integration incorporates the upstream design information and the downstream fabrication as well as construction; information through digital systems is needed in digital fabrication to ensure design and fabrication align (Ng et al. 2022). State-of-the-art digital fabrication includes additive manufacturing (e.g., 3D printing) and subtractive manufacturing, [e.g., computer numeric control (CNC) production].

As demonstrated by the literature (e.g., Bock and Linner 2015; Ng et al. 2021), digital fabrication can foster automation in construction and improve quality and efficiency. It also can reduce errors through integration in projects. However, the process from digital design to digital fabrication can bring new liability uncertainties that could increase the possibility of disputes. For example, a faulty digital fabrication operated by a downstream contractor could be due to a poorly constructed three-dimensional (3D) design model with inadequate design information passed from upstream design teams. Such liability uncertainty could be caused by the fragmented understanding of, for example, fabrication machine constraints among the project teams (Celoza et al. 2021a).

To address the liability uncertainties and avoid disputes, a clear understanding of the liability factors in the process is needed for project stakeholders to consider when designing the contracts. This helps eliminate negligence of responsibility or tort liability. Hence, this can avoid evitable claims and disputes among project teams (Gad et al. 2011; Caine and Thomas 2013). Despite the emerging adoption of digital fabrication in construction projects, the liability factors in the digital fabrication process—including the connection from digital design to digital construction—have received little attention in the current scholarship.

In the following sections, this work presents the literature review as the point of departure, the research methodology, the findings of the case study, the identified liability factors, and the proposed contractual framework. This is followed by a discussion section with the authors' recommendations for adopting digital fabrication on projects using the existing project delivery models. Thereby, this work contributes to ensuring the successful management of digital design and digital fabrication for the industry's increasing adoption of emerging technologies in design and construction. Three key contributions of this work are as follows:

1. To identify and rank the key liability factors for digital fabrication, this work conducted a single in-depth case study for a successful implementation of digital fabrication on a Taiwanese construction project. The research used process mapping and

<sup>1</sup>Associate Professor, Kyoto Institute of Technology, Matsugasaki, Sakyo-ku, Kyoto, 606-8585, Japan; ETH Zurich, Stefano-Francini-Platz 5, Zurich 8093, Switzerland (corresponding author). ORCID: <https://orcid.org/0000-0003-2610-3561>. Email: [ng@kit.ac.jp](mailto:ng@kit.ac.jp)

<sup>2</sup>Assistant Professor, Delft Univ. of Technology, Gebouw 8, Julianalaan 134, BL Delft 2628, Netherlands; ETH Zurich, Stefano-Francini-Platz 5, Zurich 8093, Switzerland. ORCID: <https://orcid.org/0000-0002-0957-484X>. Email: [d.m.hall@tudelft.nl](mailto:d.m.hall@tudelft.nl)

<sup>3</sup>Professor, National Taiwan Univ., No. 1, Section 4, Roosevelt Rd., Da'an District, Taipei City 10617, Taiwan. ORCID: <https://orcid.org/0000-0002-2093-2337>. Email: [shhsieh@ntu.edu.tw](mailto:shhsieh@ntu.edu.tw)

Note. This manuscript was submitted on March 7, 2022; approved on August 4, 2022; published online on October 31, 2022. Discussion period open until March 31, 2023; separate discussions must be submitted for individual papers. This paper is part of the *Journal of Legal Affairs and Dispute Resolution in Engineering and Construction*, © ASCE, ISSN 1943-4162.

**Table 1.** Recent literature and the examples of factors related to liabilities for digitalization in construction under eight categories

First author	Year	Key topic	Examples of factors					Risks		
			Actors	Resources	Conditions	Attributes	Processes		Artifacts	Values
Hamdi	2014	BIM contractual challenges	AEC professionals	—	Model ownership	Accurate in BIM for facility management	High level of detailing in BIM for facility management	Cost control Return of investment	—	—
Alwash	2017	BIM legal uncertainties	—	Shared information Negligence from professionals	Collaborative virtual space with limited liability	Admissibility of digital documents for courts	—	—	Negligence from professionals	Dissipation of shared information Data misuse
Celoza	2021	Legal factors of information management	—	Standard of care	Risk allocation in contracts Responsible control	Confidentiality	Data transition	Information preservation	—	—
Celoza	2021	BIM contract factors	General contractor Subcontractor	—	Contract provision of BIM usage by stakeholder BIM execution plan (BEP) in contracts	—	—	—	—	—

semistructured interviews to identify the sequence of design and construction activities for the digital fabrication activities.

- Next, the corresponding Delphi study was conducted among the project participants to first identify the potential liability factors and later rank their importance.
- From the Delphi method, this work proposes contractual provisions for contract design and recommends how future digital fabrication projects can consider the proposed provisions using the existing project delivery models in current practice with additional agreements, clauses, and practices.

## Literature Review

### Digital Design and Digital Fabrication in Construction

Digital design involves a data-rich design process that includes 3D design modeling, virtual design collaboration, and digital design documentation (Barlish and Sullivan 2012). State-of-the-art digital design technology is building information modeling (BIM). BIM facilitates design collaboration in a common virtual environment to cocreate data-rich 3D models. It enables simulation, monitoring, and digital twinning of construction processes as well as data management through digital systems (Wu and Hsieh 2012; Tsai et al. 2019; Ravi et al. 2021). Digital fabrication falls under the category of construction automation. It involves a digitally controlled fabrication process directly based on digital design information such as 3D geometry and coordination (Bock and Linner 2015). Digital fabrication entails a rethinking of management for the design process (Ng et al. 2020). It requires process, organization, and information integration between upstream design and downstream construction value chain (Ng et al. 2021). Recent scholarship explores lean and integrated design approaches, e.g., design for manufacture and assembly (DfMA), to manage design for digital fabrication in construction to different extents. The literature includes Bridgewater's (1993) design for automation (DfA), Bock and Linner's (2015) robot-oriented design (ROD), and Ng et al.'s (2021) design for digital fabrication (DfDFAB). However, the legal aspect has not yet been thoroughly studied to the authors' knowledge.

### Liability Factors Research for Digitalization in Construction

Past scholarship has studied liability-related factors in the field of construction management. For example, Gad et al. (2011) explored various dispute methods for risk factors such as cost overruns. Mahfouz and Kandil (2009) studied factors such as project owner's changes on clauses and the litigation outcomes of differing site conditions disputes. In this work, a liability factor is defined as a way, a mechanism, or a medium that can be responsible for impacting humans or nonhuman competency or incompetency that can contribute to improvements or failures in project performance (Celoza et al. 2021b). Through understanding the liability factors, project contracts can be designed to consider them in the early design phase so as to avoid evitable claims and potential disputes as well as to design to achieve project target values (Caine and Thomas 2013; Hyun Lee et al. 2020).

Recent literature studied factors related to liabilities for digitalization, in particular BIM adoption, in the AEC industry. This work studies liability factors under eight categories. The categorization is not limited to the approach presented in this paper. The literature and the examples of the factors are summarized in Table 1 and explained as follows. Hamdi and Leite (2014) identified the liability factors for conflicts of BIM implementation. These include cost control and return of investment as *values*, model ownership as

condition, as well as accuracy and level of detailing in BIM for facility management as *attribute* and *artifact*. Alwash et al. (2017) presented the *risk* of dissipation of shared information as *resource*, limited liability of parties in collaborative virtual space as *condition*, negligence from professionals as *condition* and *actors*, as well as the admissibility of digital documents for courts as *attribute* as the liability factors of legal uncertainties in BIM adoption. Celozza et al. (2021a) identified risk allocation in contracts as *condition*, data transition as *process*, information preservation as *artifact*, standard of care as *resources*, responsible control as *condition*, and data misuse as *risk* as the liability factors for information management. Celozza et al. (2021b) found three necessary *conditions* for the project with cost success. They include the contractor and subcontractor (actors) being contractually required to use BIM, as well as the inclusion of the BIM execution plan in contracts. Despite the emerging adoption of digital fabrication in AEC, no research has studied liability factors in the process from digital design to digital fabrication.

### Digitalization with the Existing Project Delivery Models

The current practice commonly uses four project delivery models, namely, Design-Bid-Build (DBB), Construction Management (CM), Design-Build (DB), and Integrated Project Delivery (IPD). Fig. 1 summarizes the key elements that are relevant to this work.

DBB is well known as the conventional project delivery model. It is also commonly called the traditional procurement route in the UK. DBB usually involves two fragmented procurement steps and two solicitations. First, the design teams are appointed to complete design documents for a tender process. Second, the construction teams are selected, usually by providing the bid with the lowest

price (Sullivan et al. 2017). The design process usually involves high design flexibility and low cost burden because DBB in general involves no early contractor involvement. However, DBB projects could suffer from change orders and claims due to negligence of construction know-how in the early design phase. Also, project owners usually control the assets and operations including project teams and schedules and thus they are financially liable for costs of any errors and omissions (E&O) in construction (Touran et al. 2011). Hence, DBB can “improperly presume a high degree of clairvoyance when allocating risk” (O’Connor 2009), but there are also cases when contractors “tend to be claim-oriented” (El-adaway et al. 2017).

In a CM project, the project owner usually manages all contracts separately with all parties, including hiring a construction manager as an agent with a separate contract to advise the owner and the design teams regarding construction methods and costs in the early design phase. The construction managers are usually selected based on qualifications (Ahmed and El-Sayegh 2021). In most cases, the construction manager is the general contractor for the construction (Sullivan et al. 2017). The early contractor involvement in CM can lead to relatively fewer change orders and more controllable costs and schedules while maintaining relatively high flexibility in design. The most commonly adopted derivation of CM is construction management at risk (CMR), where the general contractor (as the construction manager) provides a guaranteed maximum price contract to deliver the design during the construction phase. Hence, the owner is not financially liable for the cost above the set price (Touran et al. 2011).

DB has become more and more popular for the private sector and public projects since early 1996 when the US Congress passed the

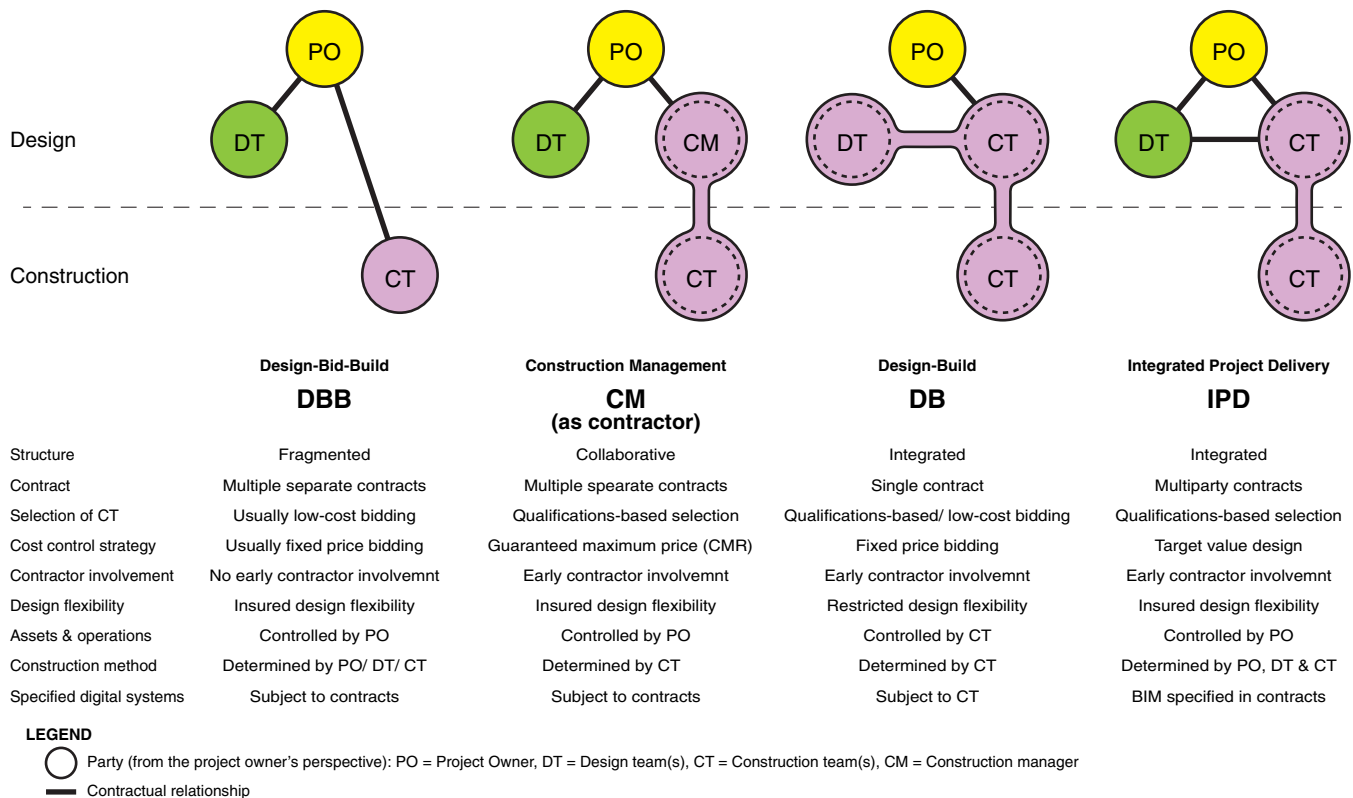

**Fig. 1.** The four commonly adopted project delivery models in current practice, Design-Bid-Build (DBB), Construction Management (CM) with the construction manager as the contractor, Design-Build (DB), and Integrated Project Delivery (IPD). Design teams (DTs) include architects and/or design engineers; construction teams (CTs) include general contractor and/or key trade contractor. Within a party, the teams can still involve multiple firms and subcontractors. In these four hypergraph diagrams, the design changes during the construction process are not illustrated.



Clinger-Cohen Act, which provides DB guidelines (Hale et al. 2009). In a DB project, the project owner can issue one single contract to the DB party (also known as the general contractor) to complete the design and construction. They are selected based on qualification and/or, most often, the lowest fixed price bidding during the request for qualifications (RFQ) and request for proposal procedures. A DB party is liable for costs and also controls the assets and operations in design and construction (Touran et al. 2011). The early contractor involvement in DB allows for shorter project duration, fixed cost, and nonadversarial relationships throughout the process. Also, it is possible that some parts of the construction can be started while the design activities are still ongoing to save cost and time (Ahmed and El-Sayegh 2021). However, DB can lead to restricted design flexibility because the typical design professional liability insurance policy, commonly known as an E&O policy in the US, might not cover dissatisfaction of design (Hyun Lee et al. 2020).

The recent development of IPD intends to break with the tradition of fragmentation and low-cost competition in the AEC industry by integrating the supply chain through multiparty relational contracting. This involves architects, general contractors, and key trade contractors who are usually selected based on qualifications (Fischer et al. 2017). Instead of costing based on detailed design, IPD projects use the lean-based target value design for designing based on detailed costing (AIA 2007). The early contractor involvement and risk-and-reward sharing mechanism foster systemic innovation across disciplines and adoption of digital fabrication with cost control (Ng and Hall 2021). IPD also involves the BIM protocol to facilitate the BIM-based design and construction process. Moreover, innovative construction methods such as prefabrication and modular construction are usually specified in IPD contracts such as the Integrated Form of Agreement (IFOA). IPD projects can suffer from disputes due to the mismanagement of collaborative resources. For example, in the Sutter Health Fairfield Medical Office Building project, the architects found it unfair that their hours of work saved were added to the incentive pool, and thus they received a smaller portion than if they had not saved the hours (AIA 2012). Recent scholarship suggests relational management theories to manage collaborative resources as the commons in an IPD project, for example, Hall and Bonanomi (2021) explored Ostrom's (2015) common pool resource governance to enable an agile, decentralized, and transparent governance structure, liability waivers, early contractor involvement and joint decision-making among multiple parties in IPD projects. However, how they can manage the integrated process of digital design and digital fabrication in an IPD project has not yet been examined.

For each of the four project delivery models, there is little to no research that investigates how they need to change in response to digital fabrication adoption. More broadly, there have been calls from scholars to investigate how new digital technologies impact project delivery models (Whyte 2019; Ahmed and El-Sayegh 2021).

### Research Questions

To summarize the reviewed literature, there is a research gap in liability factors and contracting for design for digital fabrication projects in current practice. This can lead to conflicts and large claims and disputes among project parties. To assist the increasing number of project stakeholders in designing for digital fabrication, there is an urgent need to understand the liability factors in the process of digital design and digital fabrication and the corresponding contract design for digital fabrication for the main types of project delivery models. This work fills the gaps by addressing three research questions as follows:

1. Who and what are involved in the process from digital design to digital fabrication?

2. What are the liability factors involved in this process?
3. How can the important liability factors be considered for different project delivery models to successfully contract the design for digital fabrication?

### Methodology

To address the research questions, this work comprises a two-stage research design for a single case study as shown in Fig. 2. Stage 1 involves a descriptive case analysis of Case R in Project Q. To illustrate the timeline and the stakeholders involved, a process map was developed. Stage 2 involves a three-round Delphi survey of 14 selected stakeholders from Project Q to identify 163 liability factors under eight categories. Based on the findings, this work proposes a conceptual framework for contract design considering the important liability factors.

#### Stage 1: Case Study Research and Process Mapping

To address the first research question, the first author conducted case study research on Case R in Project Q in Taiwan from March to September 2021. Primary data collection occurred through a review of project documents and schedules, and so forth, as well as 21 semistructured interviews with the project stakeholders. The first author then mapped the design-fabrication process of Case R in a swimlane diagram to illustrate the tasks and information flow from design to construction completion with validations by the project stakeholders (Ng et al. 2021).

This work employs an extended deep dive into a single case study using a case study approach and Delphi surveys of experts, who interpreted identical questions in identical ways to confront the reliability problem and achieve a consistent set of criteria for the data selection. The standardized interviews thus homogenized all experience by keeping the external conditions fixed to transfer their situational experience to situational knowledge to generate grounded theory with decontextualized generalizations from the systematic analysis of data (Burawoy 1998).

#### Stage 2: The Delphi Method

The Delphi method is a systematic multistage research approach to acquire detailed feedback on a specific topic from a preselected group of experts. It consists of anonymity, controlled feedback, and statistical group response (Dalkey 1969). The Delphi method involves an iterative process with various rounds, three in this work, of structured surveys (Hallowell and Gambatese 2010). The steps were defined based on Dalkey (1969) and Okoli and Pawlowski (2004). The Delphi method was chosen because it would identify liability factors from both the case study and expert experience and prioritize these factors based on expert experience. This iterative process allows the interviewees to first propose the factors based on their first impressions, then review feedback from others and revise their responses to gain consensus. Also, this method allows surveys to be conducted asynchronously and digitally (Celoza et al. 2021a), which suits the constraints during the pandemic period, when the research in this work was conducted. Furthermore, this method helps researchers develop frameworks based on the resultant data set. The Delphi method has already been adopted in much construction engineering and management research. For example, Giel and Issa (2016) and Celoza et al. (2021a) adopted the Delphi method to identify BIM-related competencies for developing a framework for evaluation and legal factors impacting information management, respectively; Ruhlandt et al. (2020) identified the drivers of data and analytics utilization within smart cities to

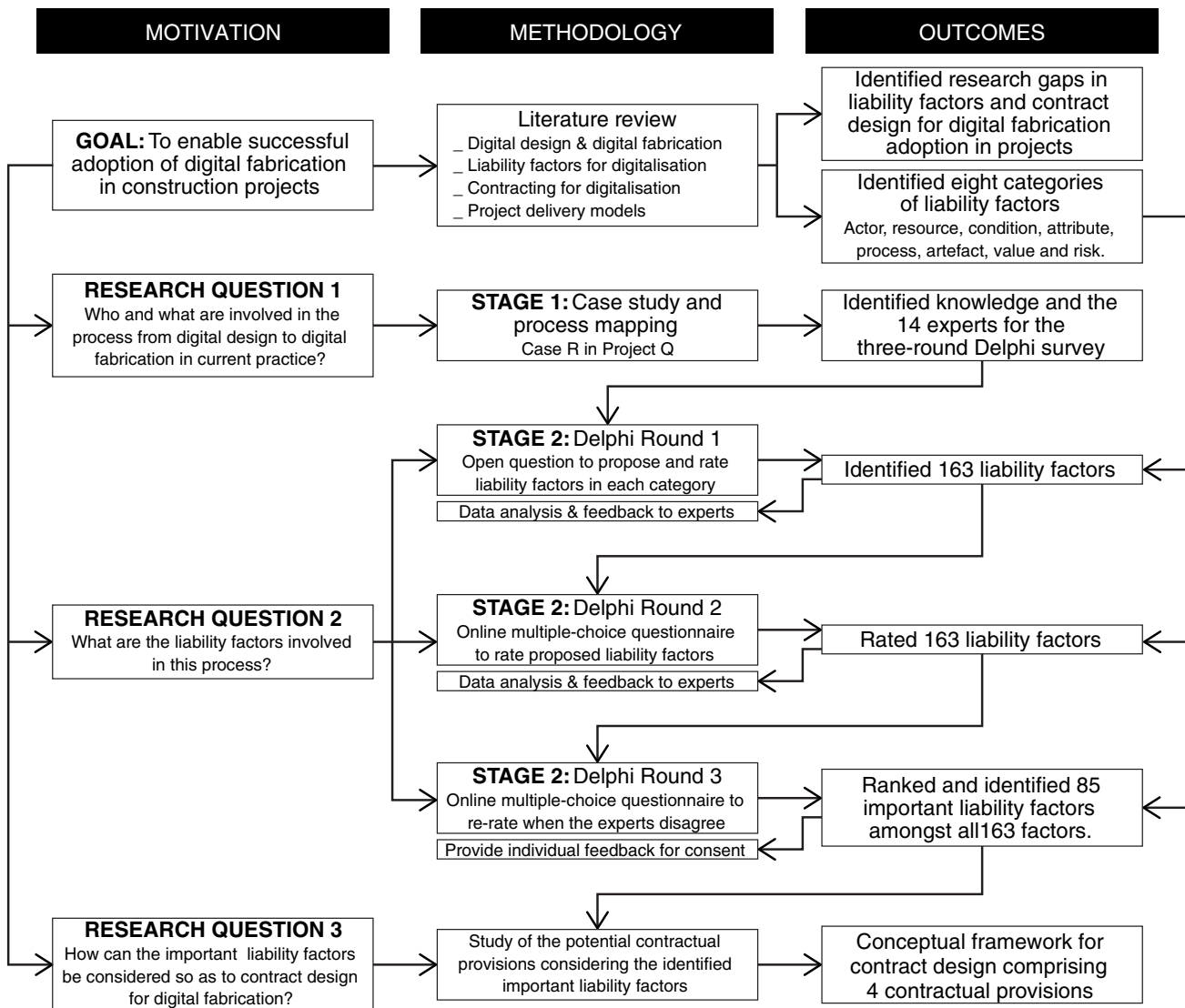

Fig. 2. Research methodology in this work.

develop a conceptual model; and Gunduz and Elsherbeny (2020) identified key operational factors to develop a contract administration performance framework.

### Delphi Surveys Design

Based on the study of Case R, 14 stakeholders from Project Q were selected through snowball sampling as the experts for the Delphi surveys in Stage 2. They were selected because they had strong responsibility and influence during the process of adopting the digital fabrication technology for Case R. Also, the affiliations of the selected experts were diverse to ensure the neutrality of the findings. This helps to generalize the findings of the proposed liability factors. Their qualifications can be found in Table S1. Although Experts 2 and 11 have no experience in contracts and working abroad, they had been extensively involved in the technical work for preparing the implementation of digital fabrication. Their work influenced digital fabrication's liability on Project Q. Hence, the liability factors during the digital design and digital fabrication processes proposed by these two experts are valid for the Delphi study. Moreover, the factors proposed by them in Round 1 were further validated by other experts in Round 2.

The first author of this work conducted the three-round Delphi survey from May 2021 to January 2022. The survey design follows Okoli and Pawlowski (2004), Ruhlandt et al. (2020), and Celozza et al. (2021a). Even though many survey participants had prior relationships from working together on the project, during and after the Delphi surveys the experts' identities and their responses remained anonymous to limit the effect of dominance bias (Dalkey 1969; Hallowell and Gambatese 2010). The experts were asked to identify the liability factors in the process from digital design to digital fabrication and rate the importance of liabilities for future digital fabrication adoption in projects based on their experience in Project Q. Round 1 involved interviews with open questions. Each expert was asked individually to propose important liability factors and rate their importance between 1 (marginally important) and 5 (highly important). Based on the literature, all proposed liability factors were categorized into eight categories: actor, resource, condition, attribute, process, artefact, value, and risk. The responses from each expert were documented digitally and sent back to the individual for their consent. After Round 1, the authors received in total 163 liability factors, which were sorted into eight categories, proposed by all 14 experts severally. In Round 2, each expert received a unique online questionnaire with all the factors

that were not proposed by that expert. They were asked to rate each given factor with the importance in liability between 0 (not important) and 5 (highly important). They could answer “do not know/decline to answer,” which would be excluded from the calculation of the mean values. The responses from each expert were documented digitally and sent back to the individual for consent. Round 3 involved a common set of an online questionnaire with all the ratings of the liability factors collected in the first two rounds. Each expert was asked to rerate individually if they disagreed with any of the ratings. The final responses from all experts were documented and sent back to each for their consent.

### Case Study and Stakeholders and Process Mapping

Project Q is a NT\$ 10.7 billion (USD 360 million) theater project with a gross floor area (GFA)–40,000 m<sup>2</sup> single building under a 35,000 m<sup>2</sup> complex geometry roof structure. The project design started in 2004 and construction was completed in 2016. This work focuses on the study of Case R, the digital fabrication of 4,500 pieces of 1-mm-thick, 40-cm-wide metal standing seam profiles, each having a unique geometry and unrestricted length, on top of the multiskin roofing system supported by a steel tubenet structure underneath. Case R in Project Q was selected for study in this work because

1. This case involves a bespoke design process for adopting a standardized digital fabrication process with an off-the-shelf machine. The design for digital fabrication in Case R solely involves the adoption instead of developing the technology itself or configuring the fabrication process.

2. Project Q adopted a conventional DBB project delivery model, which is still the most commonly adopted model in current practice worldwide.
3. Despite the tremendous disputes involving approximately USD 8 million mainly due to project schedule overruns and design changes during construction, Case R is considered relatively successful among all other cases within Project Q in terms of meeting the tight schedule and design intents.

Fig. 3 presents the process from digital design to digital fabrication in Case R. The overall process was relatively sequential. Design for digital fabrication happened during the construction phase. The project owner Firm 10 was responsible for contracting the general contractors Firm 5 for the two tender packages: the structural package and the envelope package. After being appointed, Firm 5 set up a new BIM division with BIM consultants to develop the 3D BIM models for construction. Firm 5 was responsible for contracting all the subcontractors, including the digital fabrication trade contractor Firm 6. Firm 6 was legally responsible for the fabrication in Case R by appointing the fabricator Firm 7. Firm 7 consists of two teams: one conducted the fabrication on-site in Taiwan, and the other conducted the point-cloud data analysis at their headquarters in Germany. Firm 7 was not legally responsible for the risks in Case R except for machine failure, which did not happen in this case.

After the tendering, Firm 5 set up a new BIM division with BIM consultants to develop the 3D BIM models for construction since Task 6. The models were constantly updated to capture the construction information. The entire roofing structure in Project Q was constructed module by module. The complex geometry and multiskin roofing system deviated from the planned 3D BIM

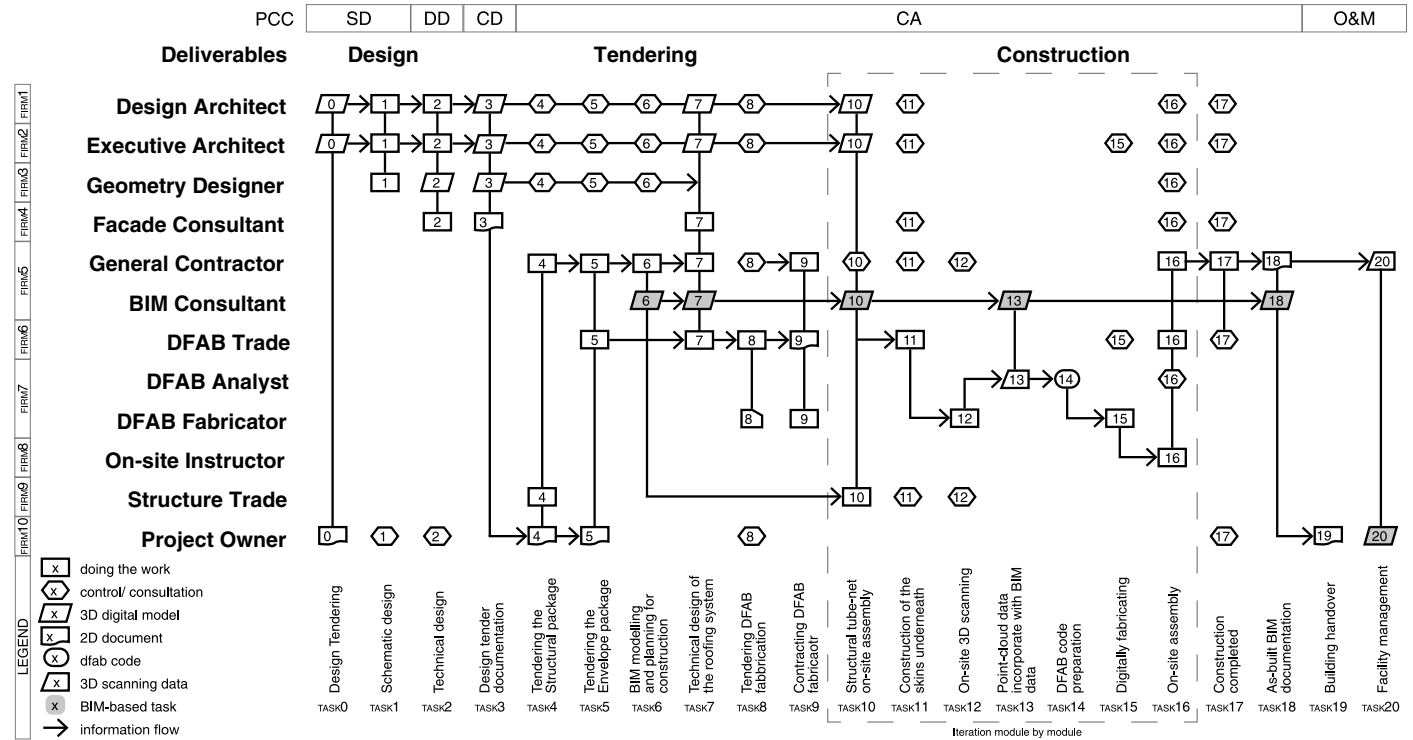

**Fig. 3.** Project Q Case R stakeholder and process mapping. The x-axis represents the timeline of the design process, which does not represent the exact process time spent on each task. On the y-axis, each row presents a role or a group of people with the same role. The number represents a task. An arrow from one icon to another represents an information flow and/or knowledge exchange with iterations. The process starts at Task 0 and goes from left to right. DFAB = digital fabrication; SD = schematic design stage; DD = design development stage; CD = construction documentation stage; CA = construction administration stage; and O&M = operation and maintenance stage.

models due to delamination of the skins within the roofing system and construction tolerance errors after the structural tube-net and the multiskin systems underneath the standing seam were constructed. When one module of the roofing system had been constructed after Tasks 10 and 11, Firm 7 used a 3D scanning camera operated by one person to scan the geometry of the modules of the constructed skin and structure system at Task 12 to create 3D point-cloud data and incorporate that with the BIM data from Firm 5 at Task 13. The corresponding digital fabrication codes were then generated at Task 14 to control the machine to bend a standardized metal sheet to a singly or doubly curved profile at Task 15. The process from Task 12 to Task 15 was to ensure that each fabricated standing seam profile would perfectly fit the constructed roofing system underneath and the adjacent profiles constructed in the previous module. The on-site assembly instructor Firm 8 was appointed to assist Firms 5 and 6 to assemble each profile fabricated with a stranding machine at Task 16. Then the standardized process from Task 12 to Task 16 was repeated for the next module. Both Firm 7 and Firm 8 were not legally responsible for all risks of the assembly work and did not participate in the design process for adopting digital fabrication. After completion, Firm 5 continued

to assist Firm 10 with BIM-based facility management using 3D scanning technology to detect defects.

## Liability Factors in the Process from Digital Design to Digital Fabrication

Based on the case study, 14 project stakeholders from Project Q were selected as experts for the Delphi research, where 163 liability factors were identified and categorized into eight categories: 13 actors, 18 resources, 23 conditions, 20 attributes, 22 processes, 14 artifacts, 25 values, and 28 risks. Table 2 presents 85 important liability factors with their means ( $\mu$ ) above the second quartile of the cumulative mean,  $\mu$ -Q2 (mean value 3.69). The most important liability factors ranked by the expert interviewees are (1) resource—management capability, (2) resource—BIM expertise, and (3) actor—general contractor, resource—BIM modeling coordination platform, and value—reduce errors. A complete list of all 163 liability factors and their definitions can be found in Table S2. The following paragraphs explain the liability factors under each category.

**Table 2.** Eighty-five important liability factors with their means above  $\mu$ -Q2 (mean value 3.69), ranked in a descending order

Rk ( $\mu$ )	Category	Liability factor	$\mu$	$\sigma$	$\sigma$ below $\sigma$ -Q1	Contractual provision
1	Resource	Management capability	4.45	0.69	X	A
2	Resource	BIM expertise	4.43	0.85	—	B
3	Actor	General contractor	4.36	0.93	—	B
4	Resource	BIM modeling coordination platform	4.36	0.84	—	B
5	Value	Reduce errors	4.36	0.63	X	A
6	Resource	Platform's 3D interface capability	4.29	0.91	—	B
7	Condition	On-site constructability	4.29	0.83	X	A
8	Artifact	Precise 3D BIM construction model	4.29	0.83	X	A
9	Value	Improve quality/performance	4.29	0.91	—	B
10	Artifact	Integrated construction data	4.25	0.75	X	A
11	Artifact	Physical mock-up of processes	4.23	0.73	X	A
12	Process	Architectural design optimization	4.21	0.8	X	A
13	Artifact	Integrated BIM model	4.21	0.89	—	B
14	Artifact	Precise 3D BIM design model	4.21	0.7	X	A
15	Resource	Platform for performance analysis	4.17	1.03	—	B
16	Condition	DFAB information involved early	4.17	0.94	—	B
17	Risk	Design/BIM and on-site misalignment	4.17	1.03	—	B
18	Attribute	Customizable	4.15	0.55	X	A
19	Risk	Constructability uncertainty	4.15	0.8	X	A
20	Attribute	Mutual trust and sharing among teams	4.14	1.03	—	B
21	Process	Integration within packages	4.14	0.77	X	A
22	Resource	Coordination/information exchange platform	4.08	0.79	X	A
23	Resource	Technical skillset	4.08	0.95	—	B
24	Condition	Common virtual environment	4.08	0.64	X	A
25	Condition	Design-construction integration	4.08	0.95	—	B
26	Condition	Early contractor involvement	4.08	0.95	—	B
27	Process	DFAB processes optimization	4.08	0.79	X	A
28	Process	Engineering design optimization	4.08	0.67	X	A
29	Risk	Lack of skilled labor	4.08	0.95	—	B
30	Attribute	Optimizable	4.07	0.73	X	A
31	Process	Construction processes optimization	4.07	0.73	X	A
32	Artifact	Integrated 3D models	4.07	0.83	X	A
33	Value	Improve design communication	4.07	1.14	—	B
34	Resource	Affordable BIM platform	4	1.22	—	B
35	Condition	Good supervision	4	0.88	—	B
36	Attribute	Constructable	4	0.78	X	A
37	Attribute	On-site integrable	4	0.78	X	A
38	Artifact	Integrated two-dimensional (2D) drawing and 3D model	4	0.78	X	A
39	Value	Reduce uncertainty	4	1.18	—	B
40	Resource	High-performance hardware	3.93	1	—	B
41	Attribute	Modular	3.93	0.62	X	A



Table 2. (Continued.)

Rk ( $\mu$ )	Category	Liability factor	$\mu$	$\sigma$	$\sigma$ below $\sigma$ -Q1	Contractual provision
42	Condition	Information integration	3.92	1.19	—	D
43	Attribute	Certainty in cost	3.92	1.04	—	D
44	Process	Digital prefabrication	3.92	0.9	—	D
45	Process	Values engineering	3.92	1	—	D
46	Artifact	Fabrication specification	3.92	0.76	X	C
47	Risk	Expectation misalignment	3.92	0.86	—	D
48	Risk	DFAB knowledge not integrated	3.92	0.79	X	C
49	Artifact	Automated tracking systems	3.91	0.94	—	D
50	Process	Review of shop drawings	3.86	0.66	X	C
51	Attribute	Knowledge capture	3.85	0.99	—	D
52	Risk	Errors in platforms/formats exchange	3.85	1.07	—	D
53	Risk	Increase overall cost	3.85	1.07	—	D
54	Risk	Workforce training is required	3.85	0.99	—	D
55	Attribute	2D and BIM integrable	3.83	1.11	—	D
56	Attribute	Risks sharing/agile management	3.83	0.58	X	C
57	Risk	Fragmented understandings	3.83	1.03	—	D
58	Risk	Documentation misalignment	3.83	0.83	X	C
59	Actor	DFAB trade contractor	3.79	0.89	—	D
60	Actor	Executive architect	3.79	1.12	—	D
61	Condition	Flexible design	3.79	0.8	X	C
62	Process	Modularization	3.79	0.8	X	C
63	Artifact	Detailed 2D drawings	3.79	0.97	—	D
64	Resource	DFAB machine	3.77	1.36	—	D
65	Condition	Appropriate project design delivery model	3.77	1.09	—	D
66	Attribute	Automated in fabrication	3.77	1.01	—	D
67	Attribute	Ability to be prefabricated	3.77	1.01	—	D
68	Attribute	Precise design information	3.77	0.93	—	D
69	Process	Post-rationalization	3.77	0.93	—	D
70	Value	Improve capability	3.77	1.17	—	D
71	Actor	On-site assembly contractor	3.75	1.14	—	D
72	Attribute	Flexible	3.75	0.87	—	D
73	Attribute	Integrated design-build	3.75	1.22	—	D
74	Process	Lean fabrication	3.75	1.29	—	D
75	Risk	High dependency on BIM	3.75	0.87	—	D
76	Risk	High dependency on supply chain	3.75	0.87	—	D
77	Process	Performance test	3.73	1.1	—	D
78	Actor	3D modeler	3.71	1.2	—	D
79	Actor	BIM specialist	3.71	1.14	—	D
80	Actor	DFAB engineer	3.71	0.99	—	D
81	Value	Reduce construction complexity	3.71	1.33	—	D
82	Condition	Cost control	3.69	1.03	—	D
83	Process	On-site modification	3.69	0.75	X	C
84	Risk	Increase design cost	3.69	0.75	X	C
85	Risk	Lengthen design processes	3.69	0.75	X	C

Note:  $\sigma$  = standard deviation; Rk = rank; and DFAB = digital fabrication.

### Actors

Thirteen types were proposed as the important liability factors to different extents in the process from digital design and digital fabrication. They are named after their roles or professions. For example, the actor named *digital fabrication (DFAB) engineer* refers to a person or a group of people who work on the engineering of digital fabrication technology. *General contractor* was rated as the most important actor in liabilities. One reason stated by one of the surveyed experts is that in a typical project, “the general contractor is responsible for the overall construction process including planning and managing digital fabrication.” The importance of general contractor is followed by the *DFAB trade contractor* and the *executive architect*. The former is defined as an actor who is “legally responsible for the success/failure of the digital fabrication adoption in the construction process,” as quoted by one expert in this work. Moreover, one expert surveyed in this work stated that

*executive architects* are “important, in particular, for large-scale public or public–private partnership projects.” Also, two experts specified that *BIM specialist* ought to be “in-house either as a member of the general contractor or as a member of the architect team(s).”

### Resources

Eighteen types were proposed by the experts. The most important resource is *management capability*, which is defined as the capacity within multiparty project stakeholders to manage design for digital fabrication. This includes “managing and planning skill-set to integrate 3D design models for adopting digital fabrication,” as stated by one of the surveyed experts. *BIM expertise* for design and construction and *BIM modeling coordination platform* rank second and third, respectively, regarding the importance in liabilities.

They usually “come along with one another during the process from digital design to digital fabrication,” as stated by one expert in this work. They are followed by *platform’s 3D interface capability* and *platform for performance analysis*, ranking fourth and fifth regarding importance in liabilities. It can be concluded that BIM-based digital systems are in general important in liabilities.

### Conditions

Twenty-three types were proposed as the liability factors under this category. *On-site constructability* was rated as the most important condition. One reason stated by one expert in this work is that “a system fabricated digitally off-site should be integrable with other building parts during on-site assembly.” This is followed by *digital fabrication information involved early* as the second and *common virtual environment, design-construction integration*, and *early contractor involvement* as the third. The condition of *early contractor involvement* is relevant to “design for constructability,” as stated by one surveyed expert. This factor was initially proposed by 8 out of 14 experts in Round 1 of the Delphi survey.

### Attributes

Twenty types were identified through the Delphi surveys. *Customizable* ranks first in terms of importance in liabilities. One reason stated by an expert in this work is that “a customizable digital fabrication process can increase design complexity to achieve the project requirements.” *Mutual trust and sharing among team* and *optimizable* rank second and third. The former attribute was considered important because “trust is important to bring the digital design to digital fabrication with information integration from different parties,” as stated by one expert. Regarding the attribute *risk sharing/agile management*, one expert stated that “the more complex the project, the more important it is in liabilities.”

### Processes

Twenty-two types were proposed as important liability factors. *Architectural design optimization* ranks the first. It includes optimizing “the geometry of the building system to achieve both the design intents and constructability,” as quoted by one surveyed expert in this work. This is followed by *integration within packages*. Some packages can be fabricated digitally, some can be constructed manually. “Their system interfaces should be well integrated through collaborative work,” as stated by one expert in this study. *Digital fabrication process optimization*, which specifically refers to the process of adopting digital fabrication, and *engineering design optimization* rank third; while *construction process optimization*, which refers to the overall construction process, ranks fourth. It can be concluded that processes of optimization are in general important in liabilities.

### Artifacts

Fourteen types were proposed by the experts. *Precise 3D BIM construction model* ranks first. This artifact is in particular important for DBB projects because it is usually the model that provides “construction information and pricing,” including the “bill of materials and quantity takeoff,” as quoted by one expert. This is followed by *integrated construction data* from “not only general contractors but also the subcontractors involved,” as stated by one expert in this work. The third is *physical mock-up of the digital fabrication process*. Surprisingly, *virtual mock-up of the digital fabrication process* ranks 12th under this category. Also, although Case R in Project Q has demonstrated the effectiveness of using

point-cloud technology to assist digital fabrication adoption, the artifact *point-cloud files* ranks last in terms of importance in liabilities.

### Values

Twenty-five types were proposed as the liability factors under this category. *Reduce errors in the digital fabrication process* was rated as the most important value. This has been well demonstrated in Project Q, where Case R had one of the lowest errors among all other cases. This is followed by *improve quality/performance* and *improve design communication*, respectively. Surprisingly, various types of cost reduction were proposed by the experts. However, values regarding costs were not rated highly in terms of importance in liabilities.

### Risks

Twenty-eight types were identified through the Delphi surveys. The ratings of each factor under this category are in general not high compared to other categories. However, this category has the most types of liability factors. *Design/BIM and on-site misalignment* ranks first. One reason as shared by an expert is that “digital design [in BIM] and off-site digital fabrication could be fragmented with the situation on-site.” This is followed by *DFAB constructability uncertainty*. Digital fabrication is still in its early phase of adoption despite its technological advancement. One expert stated that “many stakeholders in the AEC industry are still skeptical about its performance in particular regarding constructability.” Some experts raised concerns over *cyber security*, *building codes not suitable for digital fabrication*, as well as *limited market competition/monopoly*. To the authors’ knowledge, these aspects of digital fabrication adoption have been rarely studied.

## Conceptual Framework for Contract Design

Based on the case study and the liability factors identification through the Delphi survey, this work develops the conceptual framework for contract design that considers the 85 important liability factors with their means above the second quartile of the cumulative mean  $\mu$ -Q2 (mean value 3.69). The third quartile of the cumulative mean  $\mu$ -Q3 (mean value 3.93) and the first quartile of the cumulative standard deviation  $\sigma$ -Q1 (standard deviation value 0.83) of all 163 identified liability factors are used as the thresholds to categorize the liability factors into four contractual provisions as illustrated in Fig. 4 and explained as follows:

- **Contract Provision A:** To enable a successful digital fabrication implementation in the early design phase, the design of the contract between all parties for general conditions is recommended to include these 22 highly important liability factors: two resources, two conditions, five attributes, five processes, six artifacts, one value, and one risk. For example, the contract can specify the project target value of *error reduction* and mitigate the risk of *constructability uncertainty*.
- **Contract Provision B:** The design of the contract between certain parties for general conditions is recommended to include these 19 highly important liability factors: one actor, seven resources, four conditions, one attribute, one artifact, three values, and two risks. For example, the contract between the project owner and the digital fabrication contractor can specify the *early involvement* to design for digital fabrication; the artifact of *integrated BIM model* can be included in the contract between the architect and the general contractor.

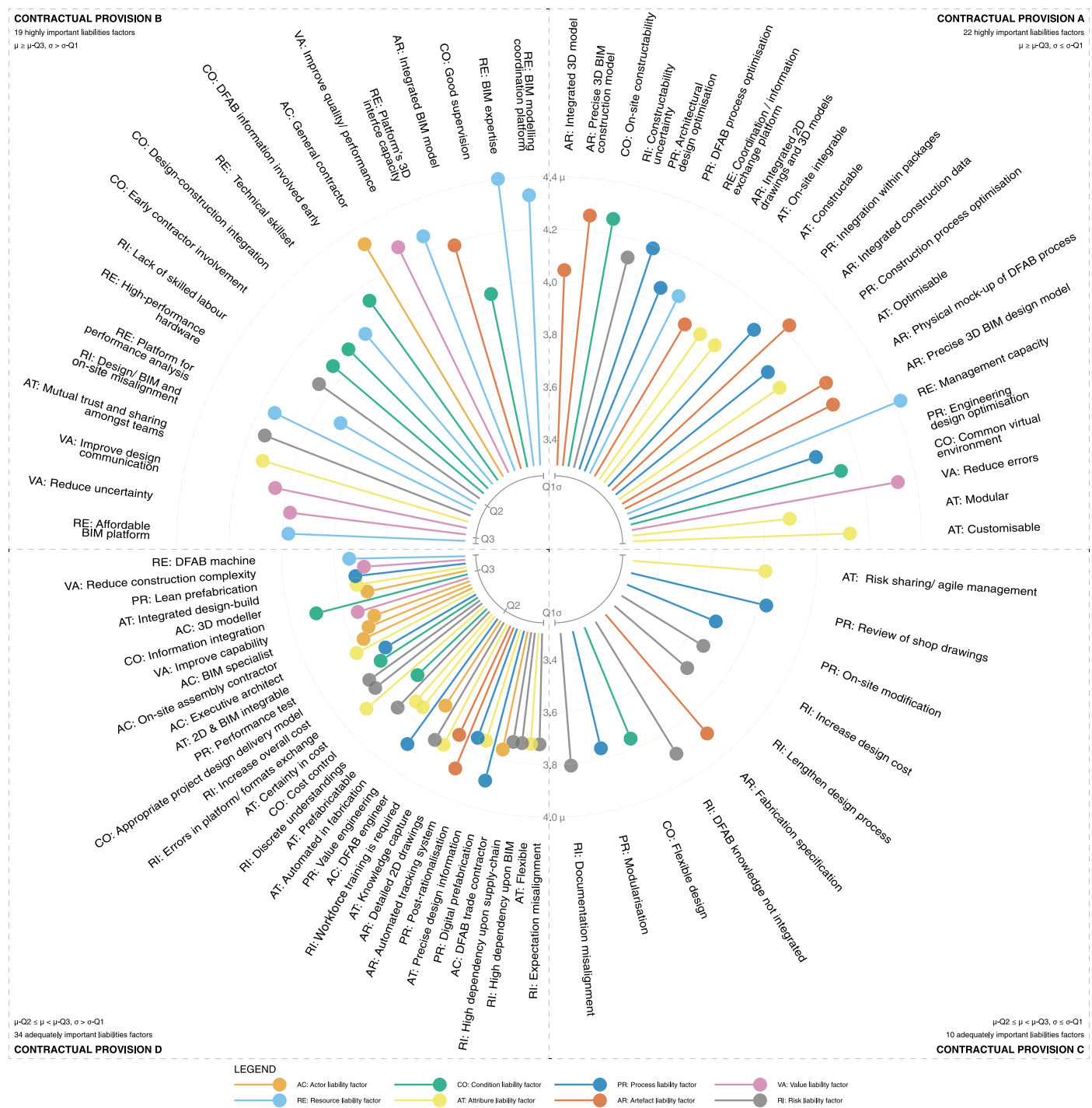

**Fig. 4.** Conceptual framework for contract design comprising four contractual provisions with the 85 identified important liability factors to enable design for digital fabrication in construction. In this radial histogram, the line for each factor is colored according to its category and the length of the bar reflects its mean ( $\mu$ ). In each sector, the factors are arranged from left to right in ascending order of their standard deviation values. The length of each line colored according to category of liability factor with a circular header represents mean value ( $\mu$ ).

- Contract Provision C:** The design of the contract between all parties for request conditions can consider these 10 adequately important liability factors: one condition, one attribute, three processes, one artifact, and four risks. For example, an *agile management for risk-sharing* mechanism for all key stakeholders can be included in contracts.
- Contract Provision D:** The design of the contract between certain parties for request conditions can consider include these
  - 34 adequately important liability factors: six actors, one resource, three conditions, eight attributes, five processes, two artifacts, two values, and seven risks. For example, an optional clause stating the project target value of *construction complexity reduction* can be included in the agreement between the project owner and the digital fabrication trade contractor; incentives can be given to teams who have *reduced construction complexity* through design for digital fabrication.

CATEGORY	LIABILITY FACTOR	SUPPLEMENTARY AGREEMENT				SUPPLEMENTARY CLAUSE			SUPPLEMENTARY PRACTICE								
		PCSA	BIM Protocol			Prescriptive tender spec.	Selective tendering		Concurrent engineering		Design-to-target value						
Resource	Coordination/ information exchange platform		DBB	CM	DB	IPD			DB								
Resource	Management capability						DBB	CM									
Condition	Common Virtual Environment		DBB	CM	DB	IPD			DB	DBB							
Condition	On-site constructability	DBB	CM				DBB	CM									
Attribute	Constructable	DBB	CM				DBB	CM									
Attribute	Customisable		DBB	CM	DB	IPD					DBB	CM	DB	IPD			
Attribute	Modular		DBB	CM	DB	IPD	DBB	CM			DBB	CM	DB	IPD			
Attribute	On-site integrable	DBB	CM				DBB	CM									
Attribute	Optimisable	DBB	CM					DB		DB	DBB	CM					
Process	Architectural design optimisation		DBB	CM	DB	IPD			DB		DB		DBB	CM	DB	IPD	
Process	Construction process optimisation	DBB	CM				DBB	CM			DBB	CM					
Process	DFAB process optimisation	DBB	CM				DBB	CM	DB	IPD							
Process	Engineering design optimisation		DBB	CM	DB	IPD					DBB	CM	DB	IPD			
Process	Integration within packages	DBB	CM				DBB	CM		IPD			DB	DBB	CM		
Artefact	Integrated 2D drawings and 3D models		DBB	CM	DB	IPD	DBB	CM									
Artefact	Integrated 3D models	DBB	CM				DBB	CM					DBB	CM			
Artefact	Integrated construction data		DBB	CM	DB	IPD	DBB	CM	DB	IPD			DBB	CM			
Artefact	Physical mock-up of process	DBB	CM				DBB	CM	DB	IPD							
Artefact	Precise 3D BIM construction model		DBB	CM	DB												
Artefact	Precise 3D BIM design model		DBB	CM	DB												
Value	Reduce errors	DBB	CM											DBB	CM	DB	IPD
Risk	Constructability uncertainty	DBB	CM						DB					DBB	CM	DB	IPD

**Fig. 5.** The 22 important liability factors in Contract Provision A in Design-Bid-Build (DBB), Construction Management (CM), Design-Build (DB), and Integrated Project Delivery (IPD) project delivery models to contract for design for digital fabrication.

## Discussion

### Contracting Design for Digital Fabrication in Existing Project Delivery Models

Further to the case study, the identification of liability factors through the Delphi survey, and the development of the contractual framework for contract design, the authors further examined how the existing project delivery models in current practice can consider the proposed contractual provisions based on the findings in this work. Based on the knowledge of the process from digital design to digital fabrication from the case study and the studies of the four existing project delivery models in current practice from the literature (e.g., Sullivan et al. 2017; O'Connor 2009; Fischer et al. 2017), the authors further proposed three ways to consider the 22 important liability factors in Contract Provision A in contracts as shown in Fig. 5:

1. Liability factors can be included in a supplementary agreement such as a preconstruction services agreement (PCSA) or a BIM protocol;
2. Factors can be included in a supplementary clause in a standard agreement, for example, in a prescriptive specification for tendering or as a criterion for selective tendering; and
3. Factors can be included as a supplementary practice, such as concurrent engineering and design-to-target value during the design for the digital fabrication process.

Three examples are presented as follows:

1. On one hand, the authors recommend the BIM protocol include the resource of a coordination/information exchange platform on a DBB, CM, DB, or IPD project; on the other hand, the authors recommend including this resource as one selection criterion when appointing the DB party on a DB project.
2. To facilitate the artifact of a physical mock-up of the digital fabrication process when designing for digital fabrication, PCSA is recommended for a DBB or CM project to enable the early involvement of the digital fabrication trade contractor to participate in the design process. Also, this artifact is recommended to

be included in the prescriptive specification for tendering the appropriate fabrication team.

3. To ensure on-site integrability, PCSA is recommended to be included in the prescriptive specification for a DBB or CM project; DB and IPD involve the corresponding contractors who are accountable for the on-site integration and thus no particular supplementary contractual consideration is necessary.

Based on Fig. 5, the authors evaluated that, among the other three project delivery models, IPD requires fewer supplementary considerations when designing the contract for design for digital fabrication. IPD could require more considerations, in particular, in the BIM protocol and with design-to-target value practice to manage projects commons (Ostrom 2015) in the integrated process from digital design to digital fabrication. The considerations can include distributed ledger technology such as blockchain on BIM-based platforms to govern collaborative resources for multi-party relational contracting.

### Contribution to Theory and Practice

This work presents the knowledge in digital fabrication adoption through an in-depth single case study of an existing project that had successfully adopted digital fabrication in practice. The work illustrates the process mapping that can provide a good reference for researchers and industry stakeholders to design for digital fabrication. Also, this work identifies important liability factors in the process from digital design to digital fabrication. Based on the findings, this work presents the contractual framework for contract design that comprises four contractual provisions to consider the important liability factors. This contributes to the body of knowledge in the legal aspect of construction management by establishing a foundation that explores the corresponding mitigation, dispute resolution mechanisms, and litigation for future digital fabrication projects. Moreover, this work elaborates on the contractual considerations of the important liability factors with supplementary agreements, clauses, and practices for existing project delivery models in current practice to foster a successful adoption of digital fabrication in the



early design phase. The proposed framework provides insights for industry practitioners to design the contracts immediately.

## Conclusion

This work aims to enable the successful adoption of digital fabrication in the early design phase in a construction project. This requires a thorough understanding of the liability factors in the process from digital design to digital fabrication. This, however, receives very little to no attention in scholarship to the authors' knowledge. Thereby, this work conducts two-stage research. The first author first studied and mapped the process of a successful digital fabrication adoption case in an existing project in Taiwan. Second, this work ranked 163 liability factors under eight categories—13 actors, 18 resources, 23 conditions, 20 attributes, 22 processes, 14 artifacts, 25 values, and 28 risks—identified through a three-round Delphi survey of 14 experts from the studied project. Among all, the resources of *management capability* and *BIM expertise* rank the top two highly important liability factors. To assist in contracting for digital fabrication adoption, the authors developed the conceptual framework for contract design that comprises four contractual provisions—A, B, C and D—with the 85 important liability factors. This work recommends including the 22 highly important liability factors in Contract Provision A when designing the contract between all parties for general conditions. These factors are further proposed to be considered in three ways—supplementary agreements, clauses, and practices—with the four existing project models, namely, Design-Bid-Build (DBB), Construction Management (CM), Design-Build (DB), and Integrated Project Delivery (IPD), in current practice. Three examples to facilitate design for digital fabrication in projects are presented.

This work contributes to the body of knowledge in construction management and contracting to ensure successful management for digital design and digital fabrication. This aims to facilitate the increasing adoption of emerging technologies in design and construction in the AEC industry.

## Data Availability Statement

Expert responses to Delphi ranking surveys may be provided upon request, and respondent information will be anonymized to keep personal information confidential.

## Acknowledgments

The authors would like to thank all 14 experts for supporting our case study research and the three-round Delphi survey in 2021–2022, as well as Dr. Robert Ruhlandt supporting the questionnaire development.

## Supplemental Materials

Tables S1 and S2 are available online in the ASCE Library ([www.ascelibrary.org](http://www.ascelibrary.org)).

## References

### Works Cited

Ahmed, S., and S. El-Sayegh. 2021. "Critical review of the evolution of project delivery methods in the construction industry." *Buildings* 11 (1): 1–25. <https://doi.org/10.3390/buildings11010011>.

- AIA (American Institute of Architects). 2007. *Integrated project delivery: A guide*. Sacramento, CA: American Institute of Architects.
- AIA (American Institute of Architects). 2012. *IPD case studies*. Saint Paul, MN: American Institute of Architects.
- Alwash, A., P. E. D. Love, and O. Olatunji. 2017. "Impact and remedy of legal uncertainties in building information modeling." *J. Leg. Aff. Dispute Resolut. Eng. Constr.* 9 (3): 04517005. [https://doi.org/10.1061/\(ASCE\)LA.1943-4170.0000219](https://doi.org/10.1061/(ASCE)LA.1943-4170.0000219).
- Barlish, K., and K. Sullivan. 2012. "How to measure the benefits of BIM—A case study approach." *Autom. Constr.* 24 (Jul): 149–159. <https://doi.org/10.1016/j.autcon.2012.02.008>.
- Bock, T., and T. Linner. 2015. *Robot-oriented design*. New York: Cambridge University Press.
- Bridgewater, C. 1993. "Principles of design for automation applied to construction tasks." *Autom. Constr.* 2 (1): 57–64. [https://doi.org/10.1016/0926-5805\(93\)90035-V](https://doi.org/10.1016/0926-5805(93)90035-V).
- Burawoy, M. 1998. "The extended case method." *Sociological Theory* 16 (1): 4–33. <https://doi.org/10.1111/0735-2751.00040>.
- Caine, C. P., and H. R. Thomas. 2013. "Negligent tort liability of the design professional." *J. Leg. Aff. Dispute Resolut. Eng. Constr.* 5 (1): 45–52. [https://doi.org/10.1061/\(ASCE\)LA.1943-4170.0000098](https://doi.org/10.1061/(ASCE)LA.1943-4170.0000098).
- Celoza, A., D. P. de Oliveira, and F. Leite. 2021a. "Identification and ranking of legal factors impacting information management in the AEC industry using the Delphi method." *J. Leg. Aff. Dispute Resolut. Eng. Constr.* 13 (4): 04521022. [https://doi.org/10.1061/\(ASCE\)LA.1943-4170.0000494](https://doi.org/10.1061/(ASCE)LA.1943-4170.0000494).
- Celoza, A., F. Leite, and D. P. de Oliveira. 2021b. "Impact of BIM-related contract factors on project performance." *J. Leg. Aff. Dispute Resolut. Eng. Constr.* 13 (3): 04521011. [https://doi.org/10.1061/\(ASCE\)LA.1943-4170.0000478](https://doi.org/10.1061/(ASCE)LA.1943-4170.0000478).
- Dalkey, N. 1969. "An experimental study of group opinion: The Delphi method." *Futures* 1 (5): 408–426. [https://doi.org/10.1016/S0016-3287\(69\)80025-X](https://doi.org/10.1016/S0016-3287(69)80025-X).
- El-adaway, I., I. Abotaleb, and S. Eteifa. 2017. "Framework for multiparty relational contracting." *J. Leg. Aff. Dispute Resolut. Eng. Constr.* 9 (3): 04517018. [https://doi.org/10.1061/\(ASCE\)LA.1943-4170.0000238](https://doi.org/10.1061/(ASCE)LA.1943-4170.0000238).
- Fischer, M., H. Ashcraft, D. Reed, and A. Khanzode. 2017. *Integrating project delivery*. 1st ed. Hoboken, NJ: Wiley.
- Gad, G. M., S. N. Kalidindi, J. Shane, and K. Strong. 2011. "Analytical framework for the choice of dispute resolution methods in international construction projects based on risk factors." *J. Leg. Aff. Dispute Resolut. Eng. Constr.* 3 (2): 79–85. [https://doi.org/10.1061/\(ASCE\)LA.1943-4170.0000067](https://doi.org/10.1061/(ASCE)LA.1943-4170.0000067).
- Giel, B., and R. R. A. Issa. 2016. "Framework for evaluating the BIM competencies of facility owners." *J. Manage. Eng.* 32 (1): 04015024. [https://doi.org/10.1061/\(ASCE\)ME.1943-5479.0000378](https://doi.org/10.1061/(ASCE)ME.1943-5479.0000378).
- Gunduz, M., and H. A. Elsherbeny. 2020. "Operational framework for managing construction-contract administration practitioners' perspective through modified Delphi method." *J. Constr. Eng. Manage.* 146 (3): 04019110. [https://doi.org/10.1061/\(ASCE\)CO.1943-7862.0001768](https://doi.org/10.1061/(ASCE)CO.1943-7862.0001768).
- Hale, D. R., P. P. Shrestha, G. E. Gibson Jr., and G. C. Migliaccio. 2009. "Empirical comparison of design/build and design/bid/build project delivery methods." *J. Constr. Eng. Manage.* 135 (7): 579–587. [https://doi.org/10.1061/\(ASCE\)CO.1943-7862.0000017](https://doi.org/10.1061/(ASCE)CO.1943-7862.0000017).
- Hall, D., and M. Bonanomi. 2021. "Governing collaborative project delivery as a common-pool resource scenario." *Project Manage. J.* 52 (3): 250–263. <https://doi.org/10.1177/8756972820982442>.
- Hallowell, M. R., and J. A. Gambatese. 2010. "Qualitative research: Application of the Delphi method to CEM research." *J. Constr. Eng. Manage.* 136 (1): 99–107. [https://doi.org/10.1061/\(ASCE\)CO.1943-7862.0000137](https://doi.org/10.1061/(ASCE)CO.1943-7862.0000137).
- Hamdi, O., and F. Leite. 2014. "Conflicting side of building information modeling implementation in the construction industry." *J. Leg. Aff. Dispute Resolut. Eng. Constr.* 6 (3): 03013004. [https://doi.org/10.1061/\(ASCE\)LA.1943-4170.0000137](https://doi.org/10.1061/(ASCE)LA.1943-4170.0000137).
- Hyun Lee, J., Y. Zhou, and B. Ashuri. 2020. "Key challenges to design professional liability in the design-build environment." *J. Leg. Aff. Dispute Resolut. Eng. Constr.* 12 (3): 04520031. [https://doi.org/10.1061/\(ASCE\)LA.1943-4170.0000413](https://doi.org/10.1061/(ASCE)LA.1943-4170.0000413).

- Mahfouz, T., and A. Kandil. 2009. "Factors affecting litigation outcomes of differing site conditions (DSC) disputes: A logistic regression models (LRM)." In *Proc., Construction Research Congress 2009: Building a Sustainable Future*, 239–248. Reston, VA: ASCE.
- Ng, M. S., M. M. Bonanomi, D. M. Hall, and J. Hackl. 2020. "Design for digital fabrication: An industry needs analysis of collaboration platforms and integrated management processes." In *Proc., 37th ISARC, Kitakyushu, Japan*, 318–325. Oulu, Finland: The International Association for Automation and Robotics in Construction Publications.
- Ng, M. S., Q. Chen, D. M. Hall, J. Hackl, and B. T. Adey. 2022. "Designing for digital fabrication: An empirical study of industry needs, perceived benefits, and strategies for adoption." *J. Manage. Eng.* 38 (5): 04022052. [https://doi.org/10.1061/\(ASCE\)ME.1943-5479.0001072](https://doi.org/10.1061/(ASCE)ME.1943-5479.0001072).
- Ng, M. S., K. Graser, and D. M. Hall. 2021. "Digital fabrication, BIM and early contractor involvement in design in construction projects: A comparative case study." *Archit. Eng. Des. Manage.* (Aug): 1–17. <https://doi.org/10.1080/17452007.2021.1956417>.
- Ng, M. S., and D. M. Hall. 2021. "Teaching target value design for digital fabrication in an online game: Overview and case study." In *Proc., 29th Annual Conf. of the International Group for Lean Construction (IGLC)*, 249–258. Lima, Peru: International Group of Lean Construction.
- O'Connor, P. 2009. *Integrated project delivery: Collaboration through new contract forms*. Minneapolis: Faegre & Benson, LLP.
- Okoli, C., and S. D. Pawlowski. 2004. "The Delphi method as a research tool: An example, design considerations and applications." *Inf. Manage.* 42 (1): 15–29. <https://doi.org/10.1016/j.im.2003.11.002>.
- Ostrom, E. 2015. *Governing the commons, Vol. Canto Classics*. 2nd ed. Cambridge, UK: Cambridge University Press.
- Ravi, K. S. D., M. S. Ng, J. M. Ibáñez, and D. M. Hall. 2021. "Real-time digital twin of on-site robotic construction processes in mixed reality." In *Proc., 38th Int. Symp. on Automation and Robotics in Construction (ISARC)*, 451–458. Dubai, UAE: International Association for Automation and Robotics in Construction Publications.
- Ruhlandt, R. W. S., R. Levitt, R. Jain, and D. Hall. 2020. "Drivers of data and analytics utilization within (smart) cities: A multimethod approach." *J. Manage. Eng.* 36 (2): 04019050. [https://doi.org/10.1061/\(ASCE\)ME.1943-5479.0000762](https://doi.org/10.1061/(ASCE)ME.1943-5479.0000762).
- Sullivan, J., M. El Asmar, J. Chalhoub, and H. Obeid. 2017. "Two decades of performance comparisons for design-build, construction manager at risk, and design-bid-build: Quantitative analysis of the state of knowledge on project cost, schedule, and quality." *J. Constr. Eng. Manage.* 143 (6): 04017009. [https://doi.org/10.1061/\(ASCE\)CO.1943-7862.0001282](https://doi.org/10.1061/(ASCE)CO.1943-7862.0001282).
- Touran, A., D. D. Gransberg, K. R. Molenaar, and K. Ghavamifar. 2011. "Selection of project delivery method in transit: Drivers and objectives." *J. Manage. Eng.* 27 (1): 21–27. [https://doi.org/10.1061/\(ASCE\)ME.1943-5479.0000027](https://doi.org/10.1061/(ASCE)ME.1943-5479.0000027).
- Tsai, Y.-H., J. Wang, W.-T. Chien, C.-Y. Wei, X. Wang, and S.-H. Hsieh. 2019. "A BIM-based approach for predicting corrosion under insulation." *Autom. Constr.* 107 (Nov): 102923. <https://doi.org/10.1016/j.autcon.2019.102923>.
- Whyte, J. 2019. "How digital information transforms project delivery models." *Project Manage. J.* 50 (2): 177–194. <https://doi.org/10.1177/8756972818823304>.
- Wu, I.-C., and S.-H. Hsieh. 2012. "A framework for facilitating multi-dimensional information integration, management and visualization in engineering projects." *Autom. Constr.* 23 (May): 71–86. <https://doi.org/10.1016/j.autcon.2011.12.010>.