

THE INSIDE

THE RING

THE OUTSIDE

---

REDEFINING IDENTITY OF THE RING A10 IN AMSTERDAM

MAGDALENA NALEPA  
EXPLORE LAB 23

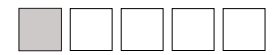

# STRUCTURE OF THE PRESENTATION

---

- INTRODUCTION
  - Fascination
  - Relevance
  
- CHAPTER 1:
  - Research
  - Conclusions
  - Problem statement
  
- CHAPTER 2:
  - Position statement
  - Project proposal
  
- CHAPTER 3:
  - Design proposal
  
- CHAPTER 4:
  - Reflection

# FASCINATION

---



Delft, A13



Zabrze, DTS



Amsterdam, Ringroad A10

# FASCINATION

RING A10



# INSIDE OR OUTSIDE THE RING?

---





CITY CORRIDOR



BARRIER



ROAD

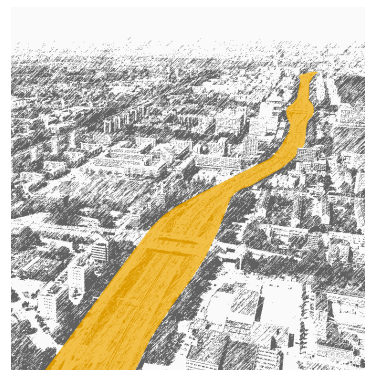

LINK



MARK

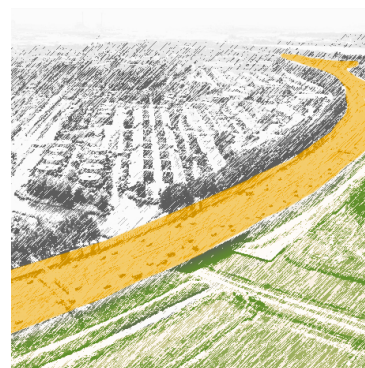

EDGE

# MULTILAYERNESS OF THE RING

---

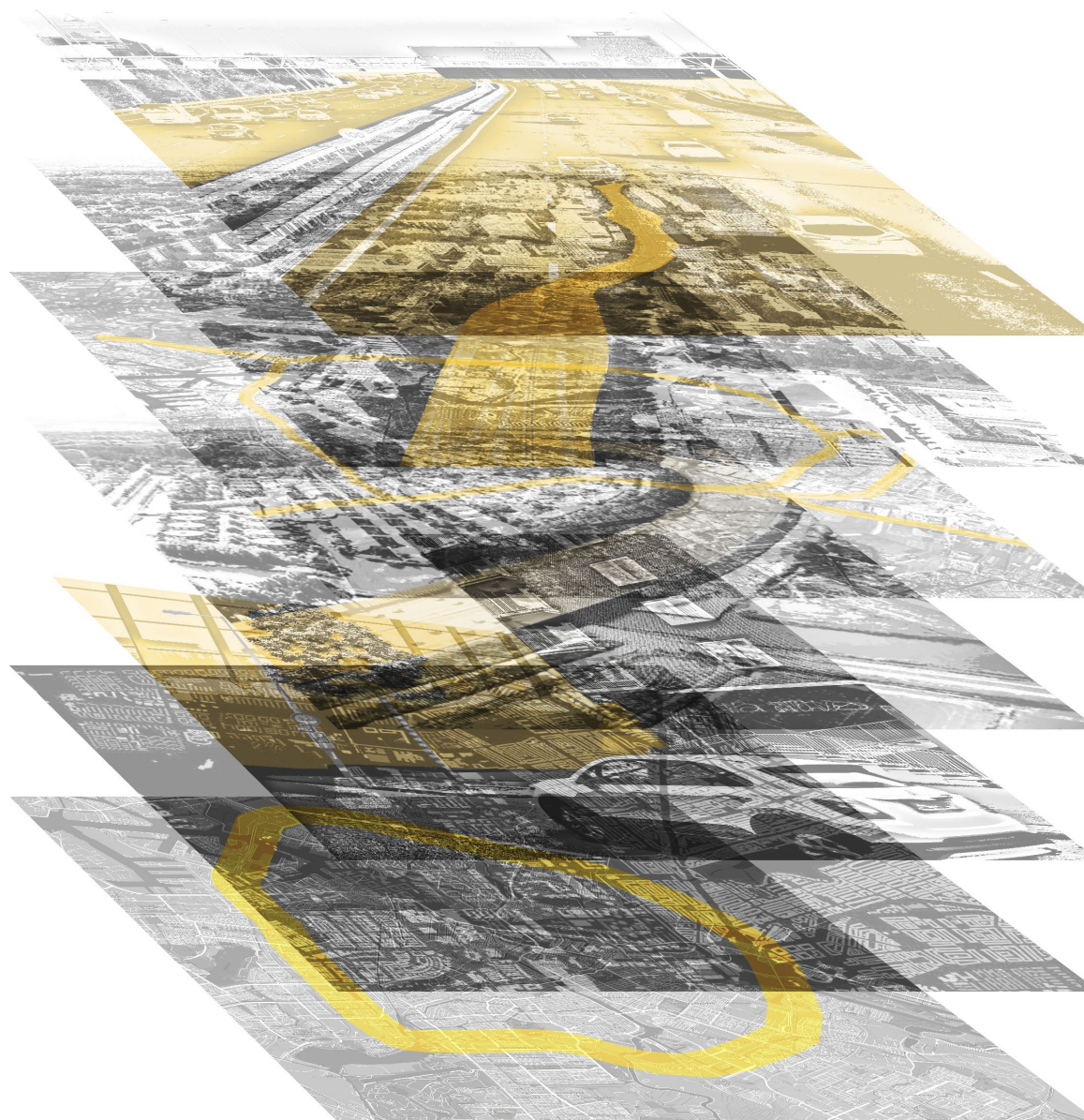

# CHALLENGES OF THE GROWING CITY

## HIGHWAY AND THE CITY



XIII Century - Dam in the river Amstel



XVII Century - Canal Rings



XVIII Century - City walls



XXI Century - Ringroad A10



# ONGOING RESEARCH

## HIGHWAY AND THE CITY



UN STUDIO - RING AMSTERDAM - BOULEVARD A10

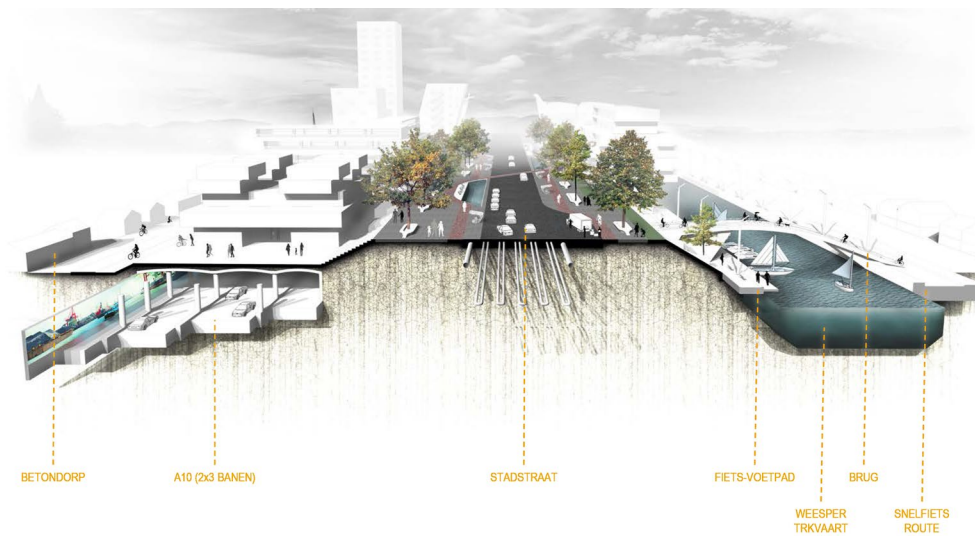

NEXT ARCHITECTS - RING AMSTERDAM - TUNNEL



VENHOEVEN CS - RING UTRECHT - MULTITRANSPORT HUB



BENTHEM CROUWEL ARCHITECTS - RING UTRECHT

# RESEARCH ON THE HIGHWAY AND THE CITY

MAIN FOCUS

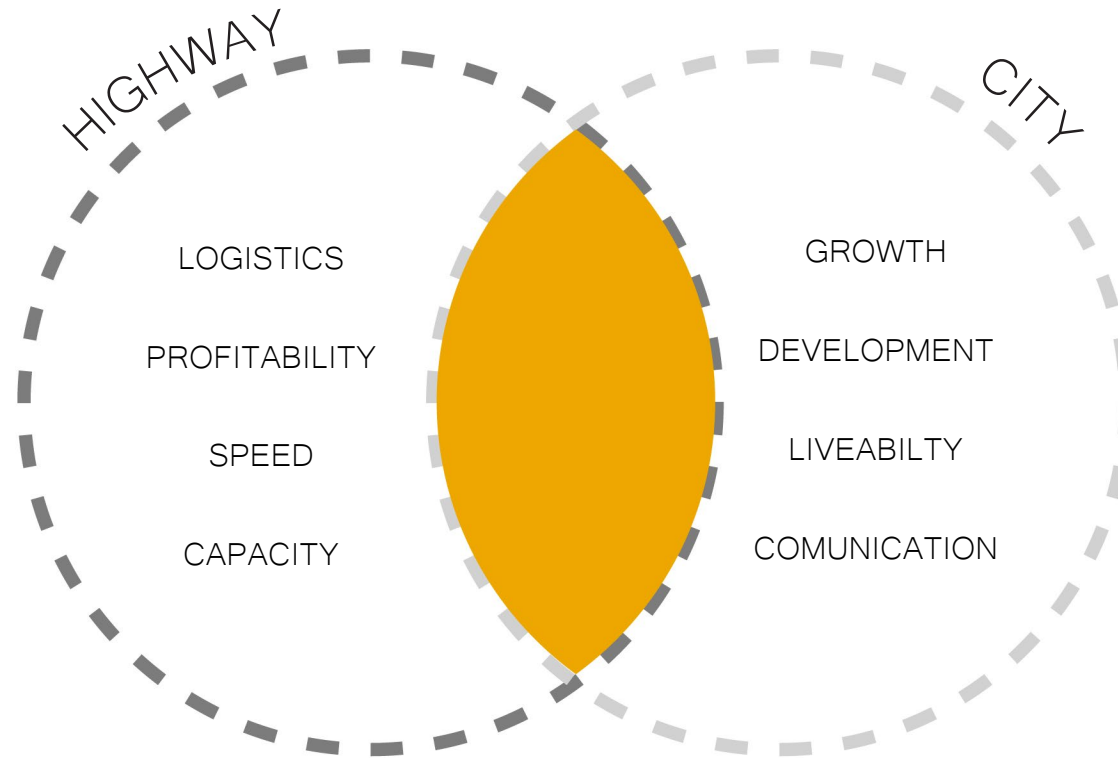

# THE HIGHWAY, THE CITY, AND THE HUMAN

MISSING PART

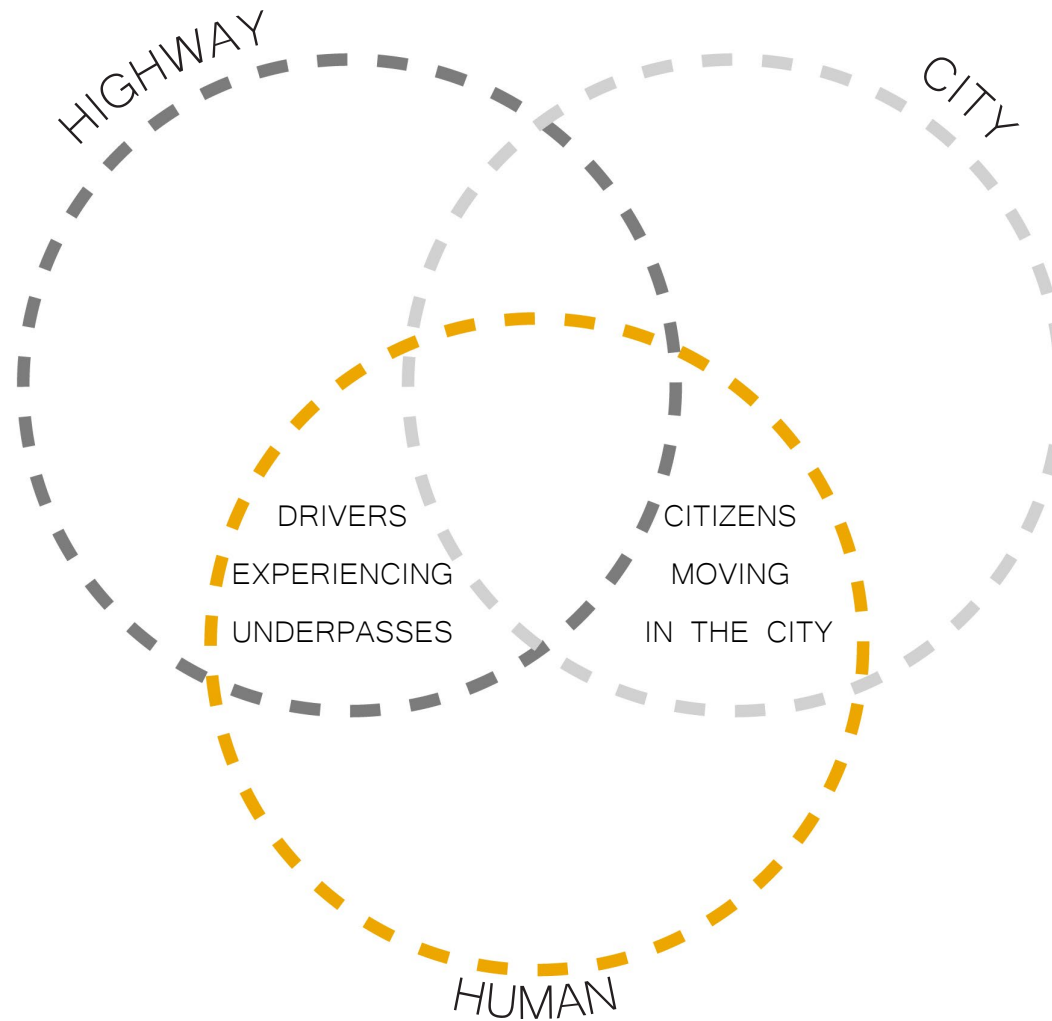

# CHAPTER I



Research

# FOCUS ON THE HUMAN

---

PARTICIPATION

RESEARCH

DESIGN

- INTERVIEWS
- WORKBOOKS
- MENTAL MAPS
- ASSOCIATIONS
- SOCIAL MEDIA
- SENSORY EXPERIENCE

- WORKSHOPS
- DISCUSSIONS
- BRAINSTORMING
- MULTIDISCIPLINARY
- CONSULTS
- PRESENTATIONS

# RESEARCH STRUCTURE

## 3 SCALES OF RESEARCH





# URBAN SCALE RESEARCH

## WORKBOOKS





RESEARCH

# DISTRICT SCALE RESEARCH

VIRTUAL IDENTITY

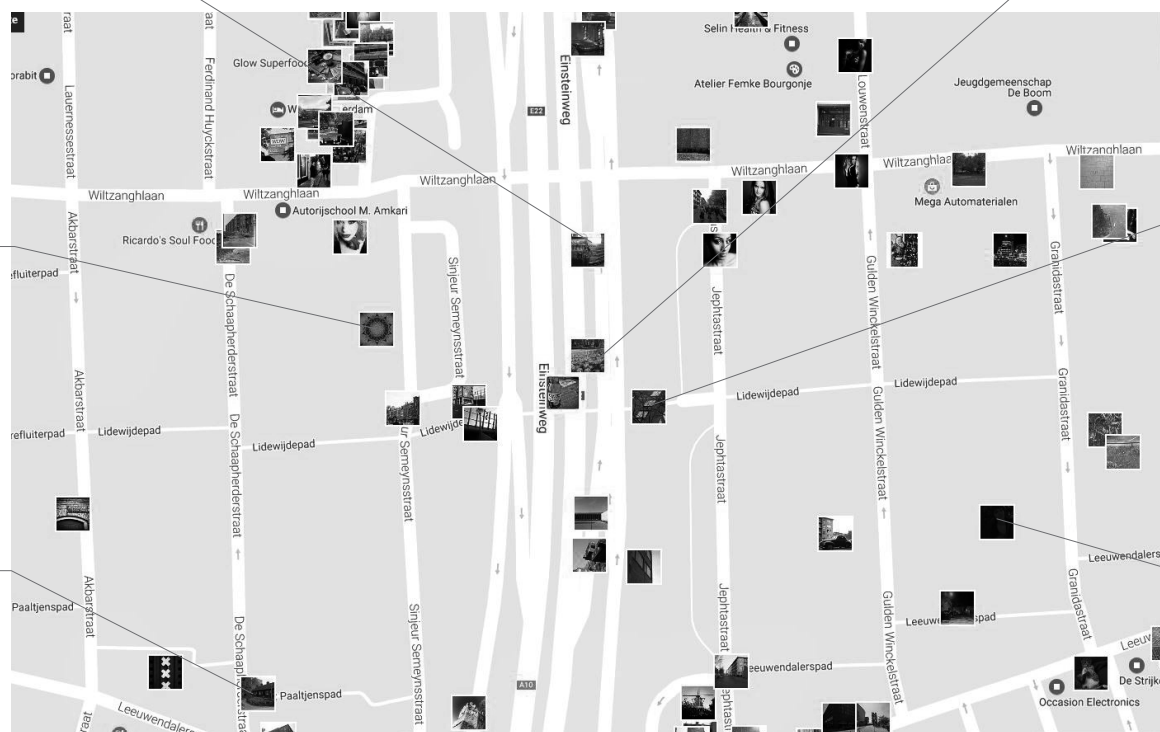



# LOCAL SCALE RESEARCH

## SENSORY WALKS



# SENSE WALKS

Research on sense of smell  
Location: Leewardorweg  
Participant: Magda

1. fresh, not distracting
2. petrol
3. very cold air, not nice, temp } strong feeling

4. rough, rattlingness, cold concrete
5. smoke
6. smother air but no smell
7. soap
8. bird

armament  
nothing  
particular

Research on sense of hearing  
Location: Leewardorweg  
Participant:

Handwritten notes in green ink describing auditory observations and environmental sounds.

Research on sense of touch  
Location: Leewardorweg  
Participant:

Handwritten notes in blue ink describing tactile observations and textures.

Research on sense of sight  
Location: Bittangham  
Participant:

Handwritten notes in yellow ink describing visual observations and architectural details.

# RESEARCH CONCLUSIONS

ROLE OF THE RING IN PERCEPTION OF THE WITHIN AND THE OUTSIDE

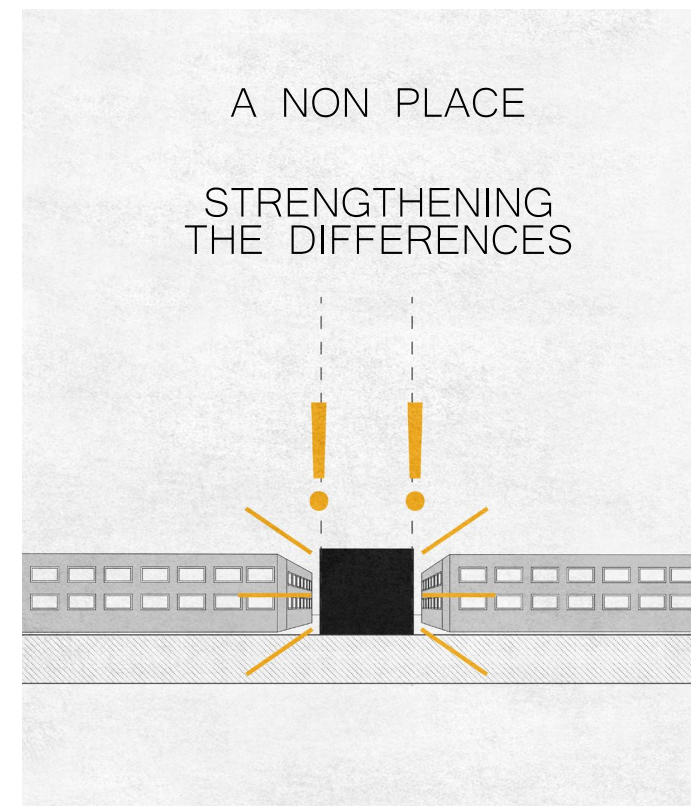
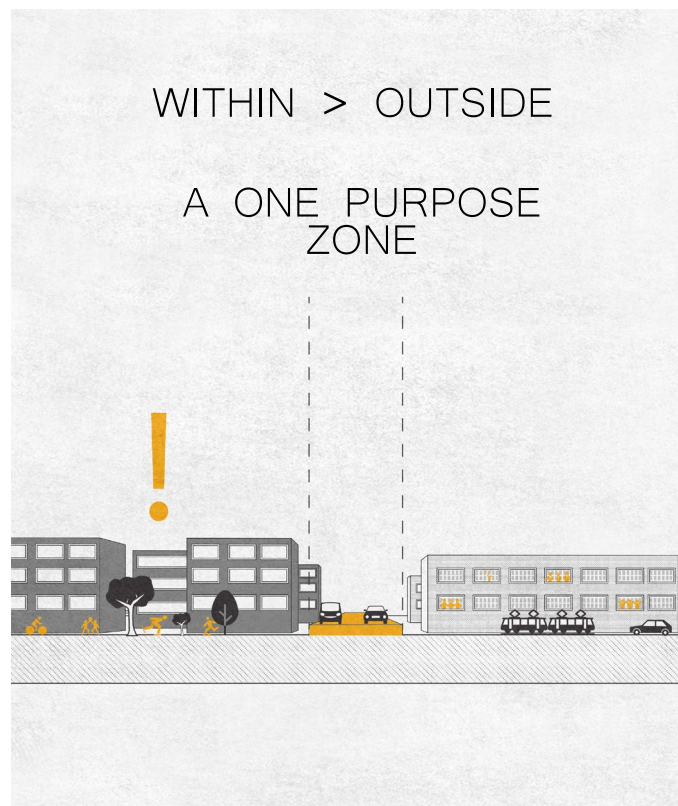

# IDENTITY IN ARCHITECTURE

---

## THEORY

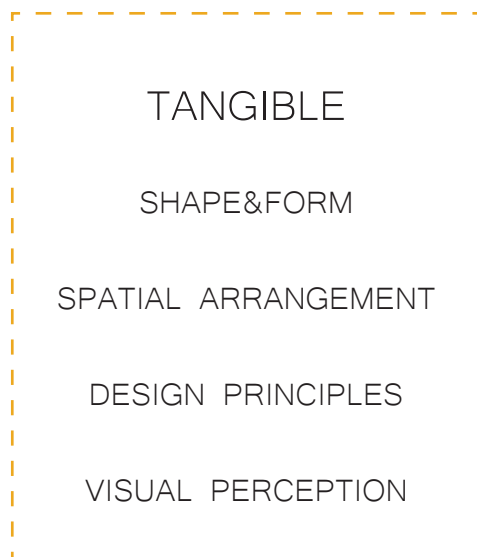

# THE GOOD, THE BAD (AND THE UGLY)

HOW TO DEAL WITH CONTRADICTIONS?

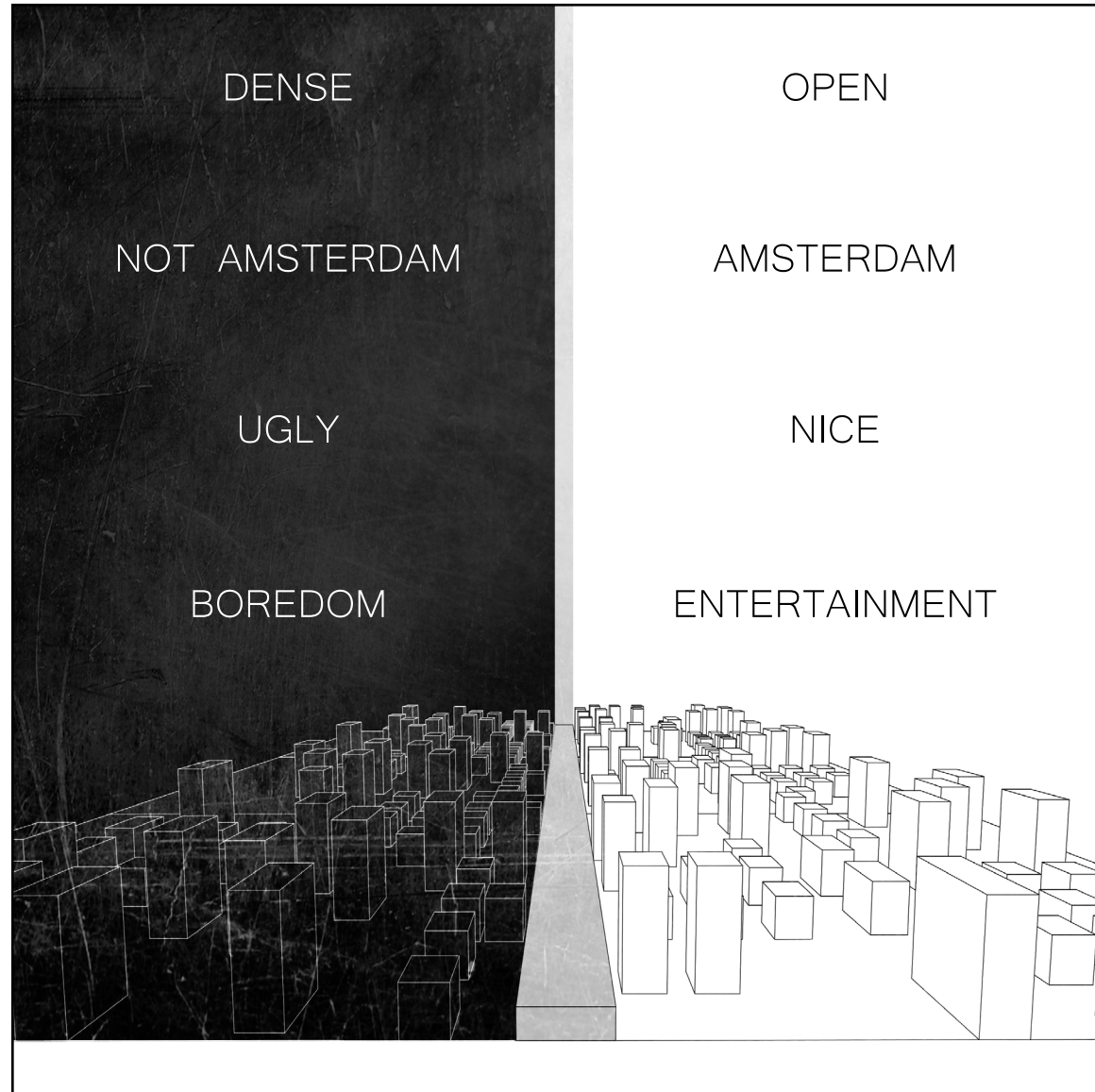

# CHAPTER II



Project proposal

# POSITION STATEMENT

## PERCEPTION OF RING A10

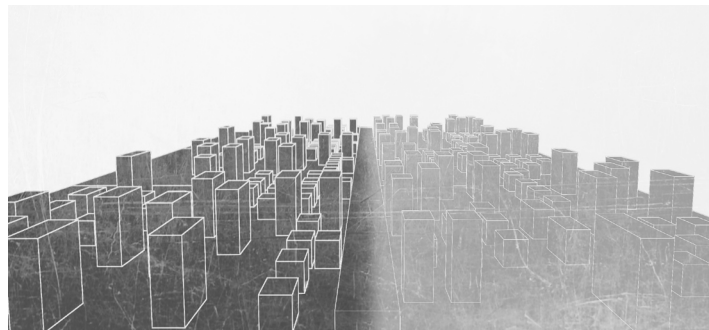
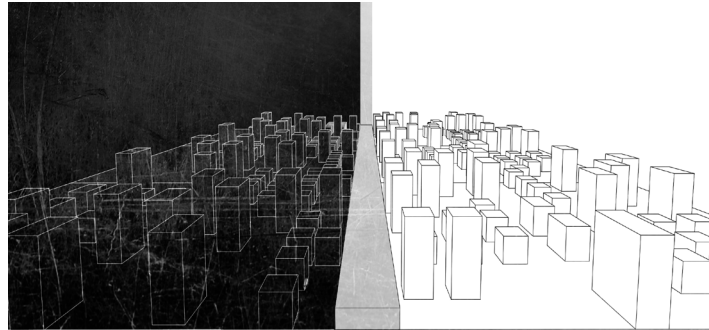

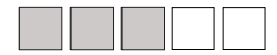

# PROJECT PROPOSAL

---

**OUTSIDE  
THE RING**

**IN  
THE RING**

**INSIDE  
THE RING**





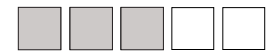

# REDEFINING THE IDENTITY OF THE RING

CREATING SENSE OF PLACE



# 3 SCALES OF INTERVENTION

HUMAN - HIGHWAY - CITY

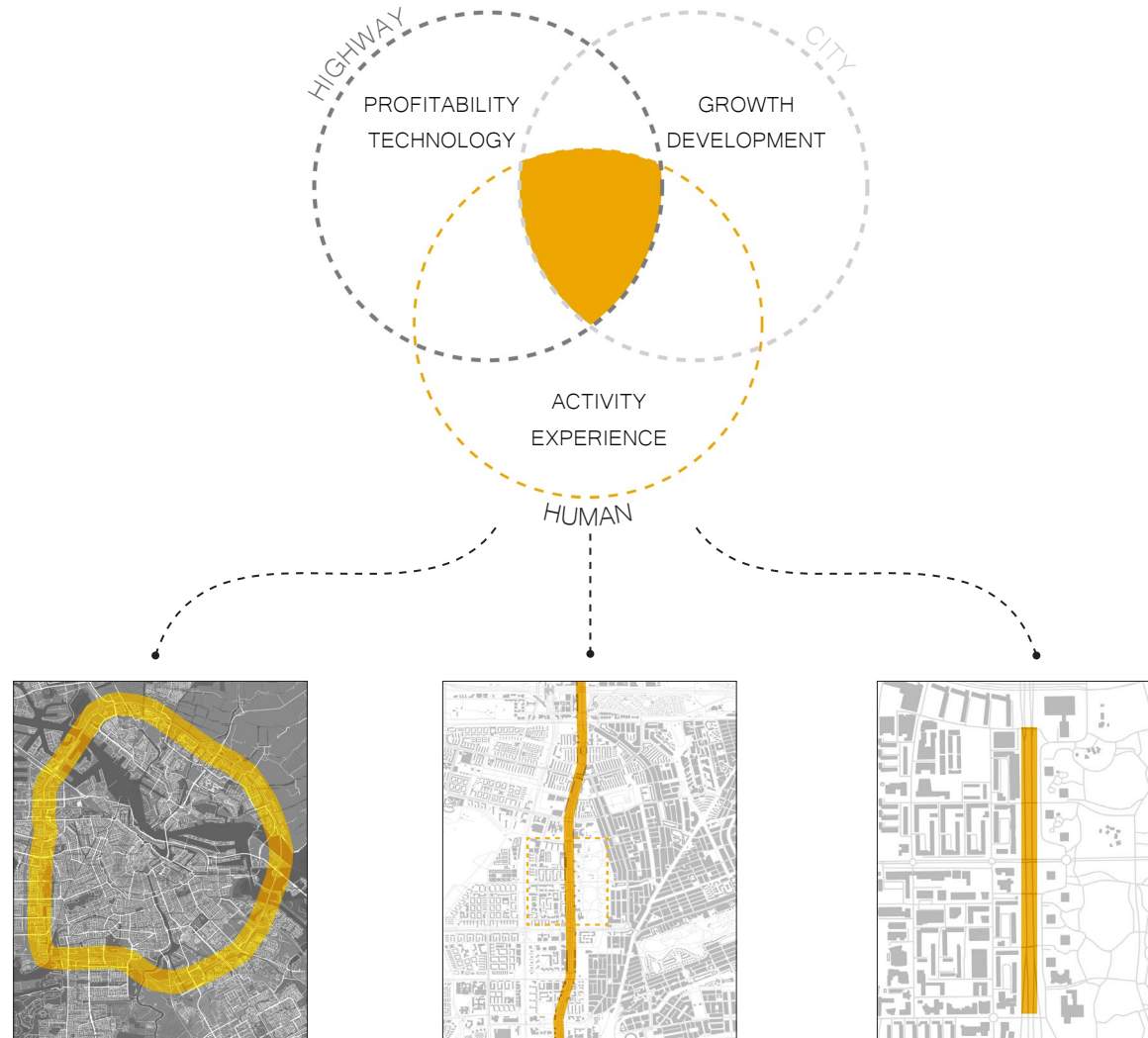

# FROM THE HIGHWAY TO THE CITY ROAD

## URBAN SCALE

DECREASING  
SPEED LIMIT

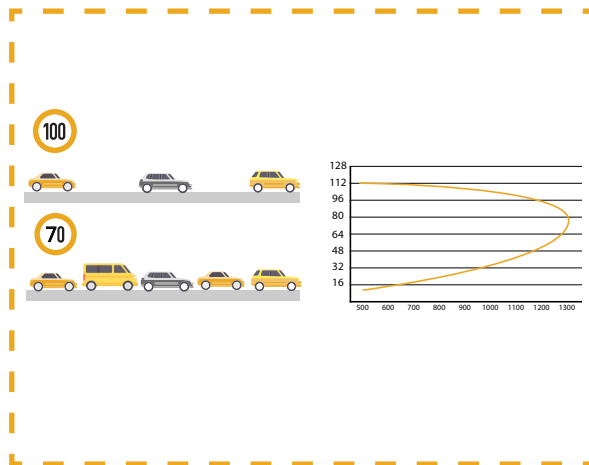

INTRODUCING  
PUBLIC TRANSPORT

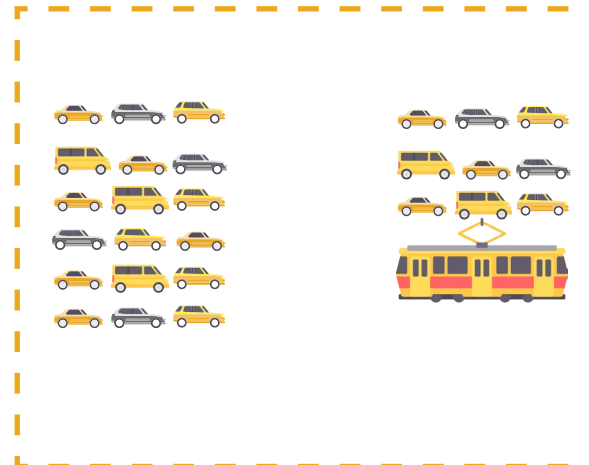

USING A5 AS  
THE OUTER RING



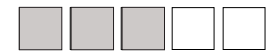

# TRIPLE RING

URBAN SCALE

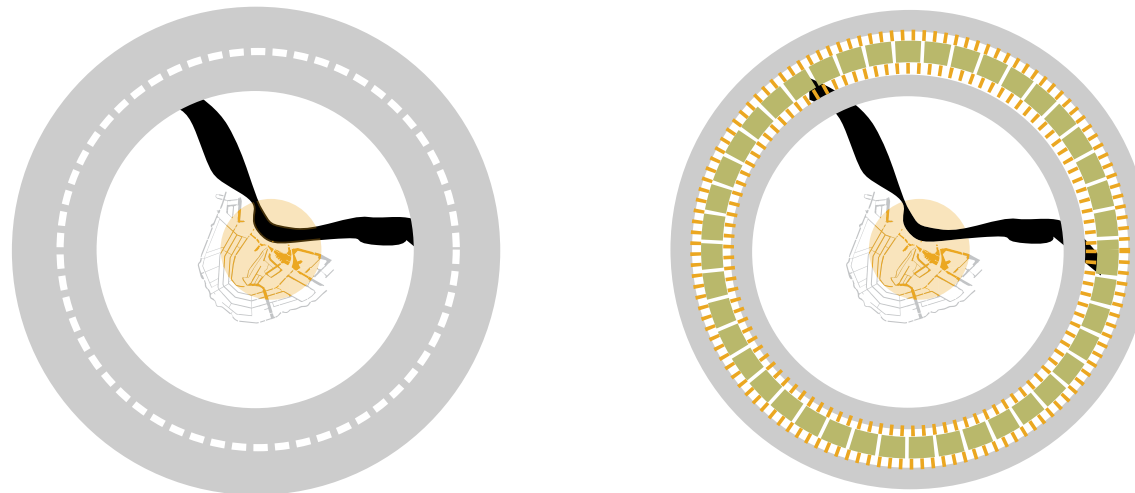
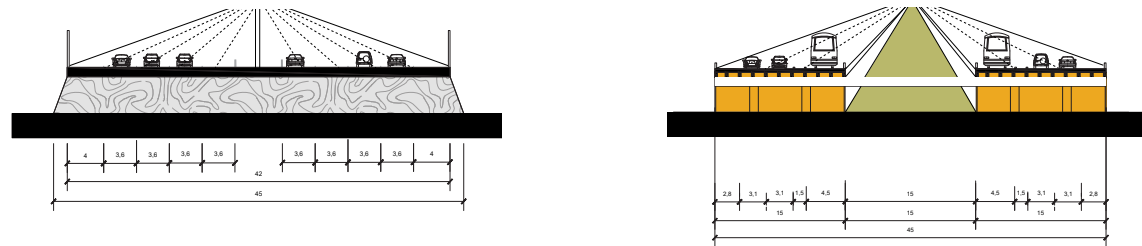

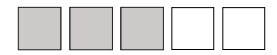

# RING AS PART OF THE CITY

URBAN SCALE



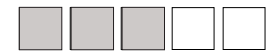

# IDENTITY OF THE RING IN THE DISTRICT SCALE

## NEW CITY CENTER FOR THE LOCALS

EXISTING BUILDINGS  
AND URBAN INTERIORS

MULTATULIWEG STADIUM  
WOW AMSTERDAM

BOS EN LOMMER PLEIN

KLIMHAL

DE SCHOOL

DE APPEL ARTS CENTER  
UNIVERSAL PICTURES INTERNATIONAL  
WORLD FASHION CENTER

DELFTLANPLEIN

SOCIAL SERVICE YOUNG&OLD



PROPOSED STATIONS  
AND NEW PROJECTS  
SLOTERDIJK

MARKET

SPORTS ARENA

EVENTS HALL

KUNSTWERK RING A10

EXHIBITION HALL

COMMUNITY CENTER

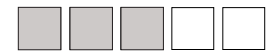

# IDENTITY OF THE RING IN THE DISTRICT SCALE

NEW CITY CENTER FOR THE LOCALS



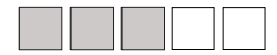

# IDENTITY OF THE RING IN THE LOCAL SCALE

ROLE OF ARCHITECTURE

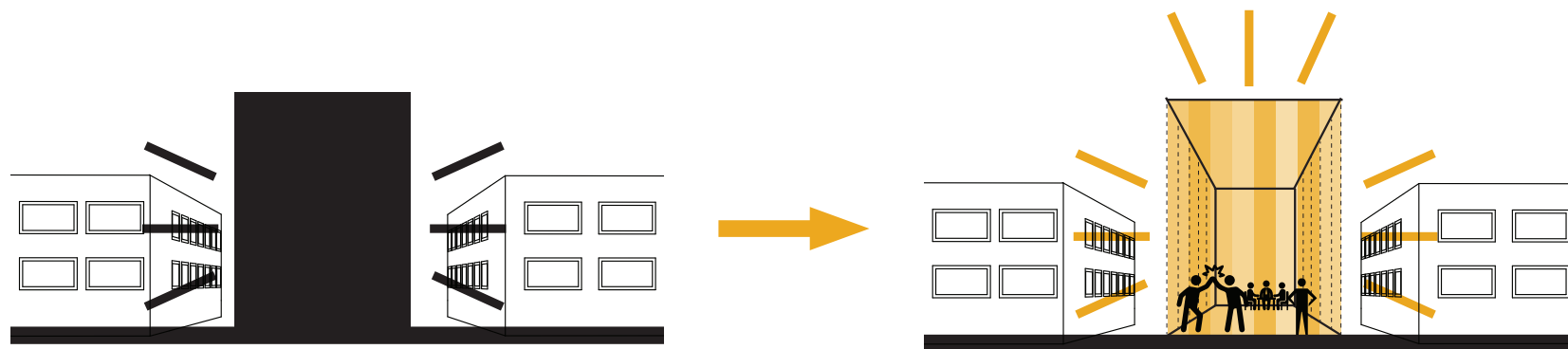



# CHAPTER III



Design proposal



# LOCATION OF THE INTERVENTION

REMBRANDT PARK, POTSJESWEG



# IN SEARCH OF THE THIRD PLACE

---



Le Centquatre-Paris  
établissement artistique  
et culturel innovant



Creative Organisation  
Slow Art Collective



Before I Die: Lively  
Interactive Street Art  
Stencil Project

# KUNSTWERK

---



CIVIL WORK

WORK OF ART

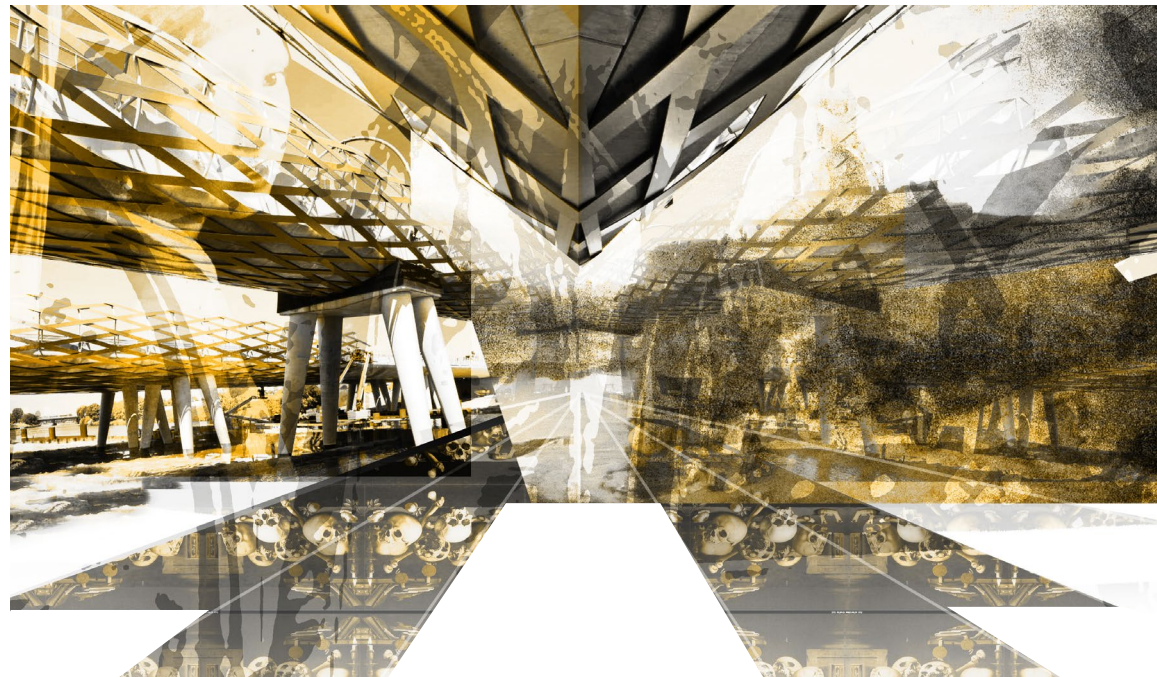

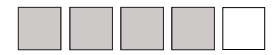

# IDENTITY IN ARCHITECTURE

---

## NEW DEFINITION

*Identity - A sum of specific material components and features which promote the unique non-material character of a place ( that distinguishes it from the environment”*

# KUNSTWERK

---

*“You can never start from scratch. It always builds upon a preexisting set of symbolic materials which form the bedrock”*

(Thompson, 1966)

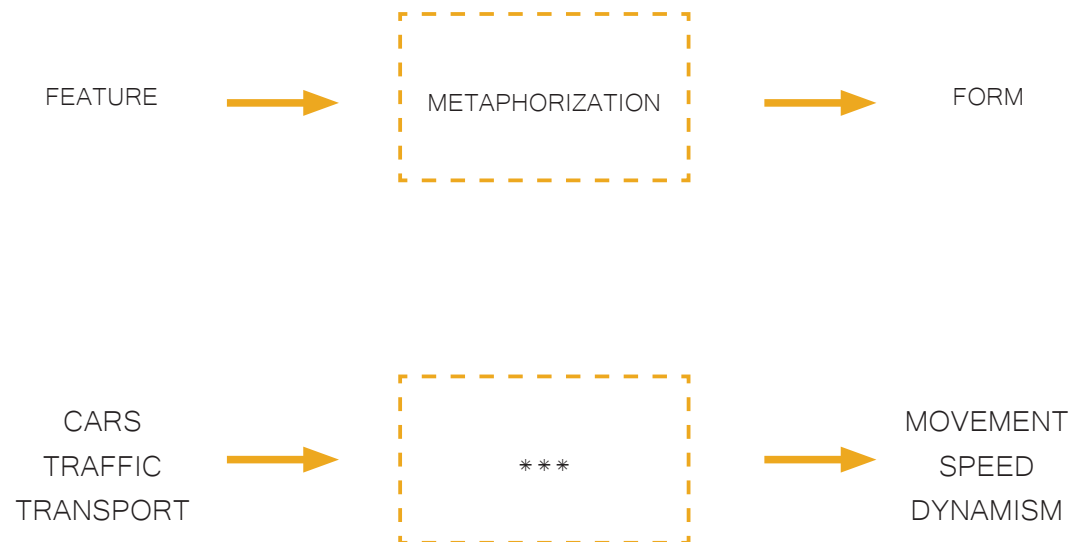

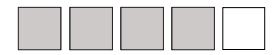

# TRANSFORMING WORDS INTO VISUALS

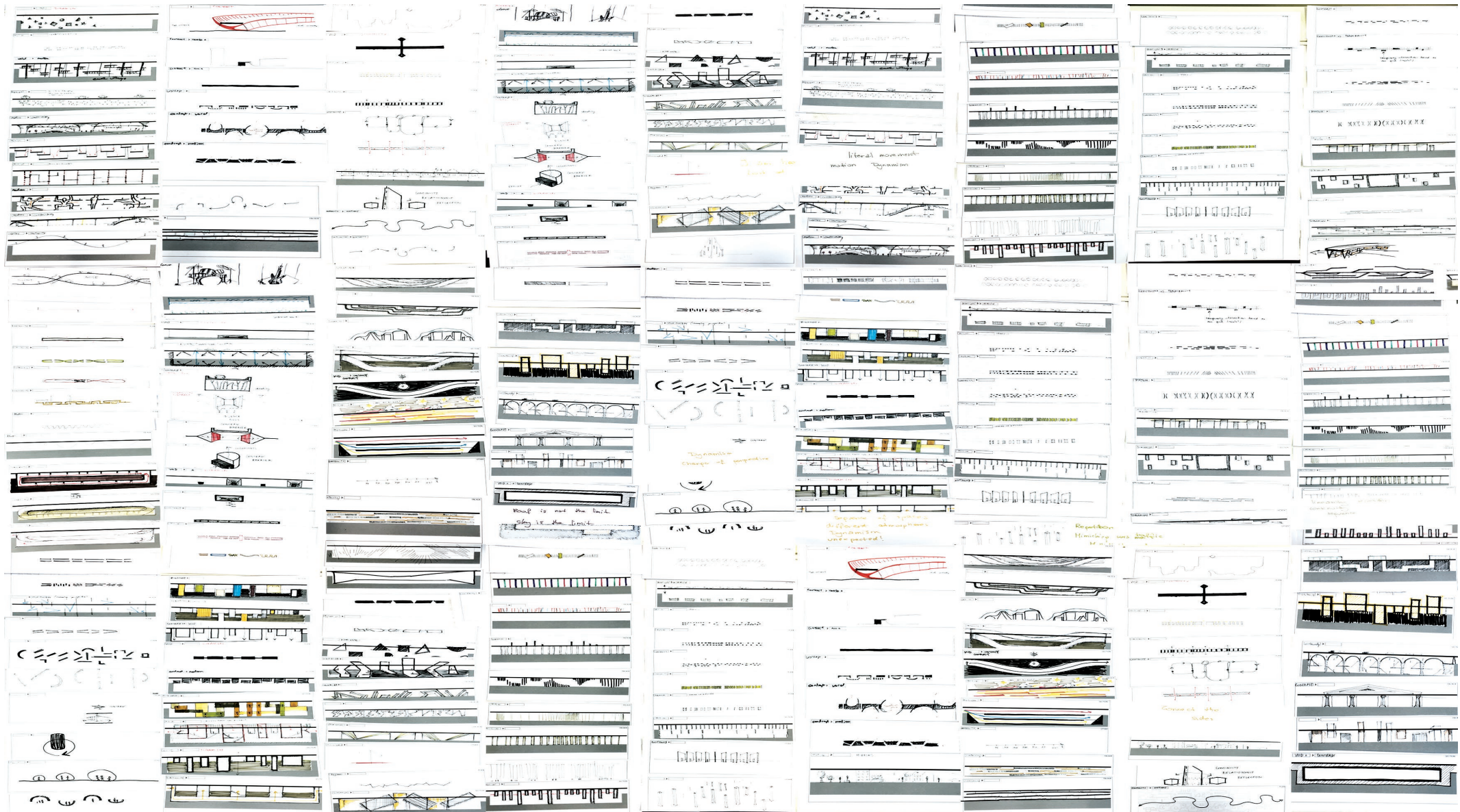

# DESIGN PRINCIPLES

METAPHOR OF  
MOTION



PERCEPTION OF SPACE

INTERNAL  
CHARACTER

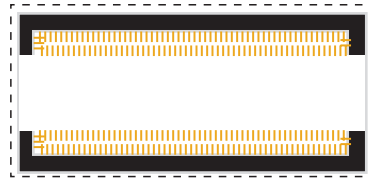

SPATIAL ARRANGEMENT

LINEARITY  
CONTINUITY

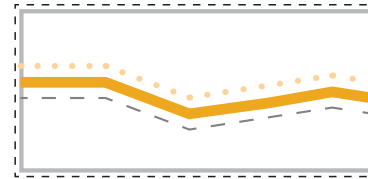

VISUAL PERCEPTION

SHOUTING  
DOMINANT

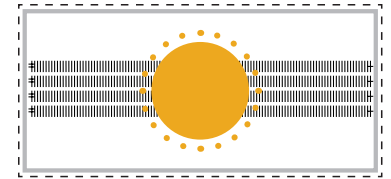

FORM & SHAPE



# DESIGN PRINCIPLES

---

METAPHOR OF MOTION

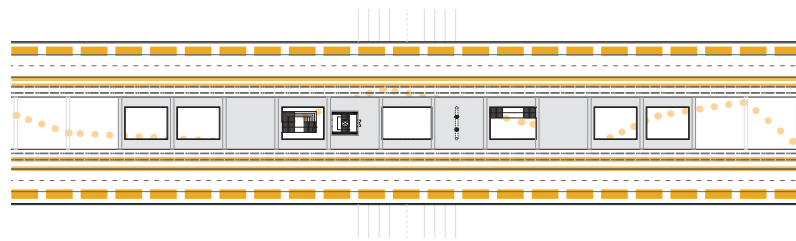

INTERNAL CHARACTER

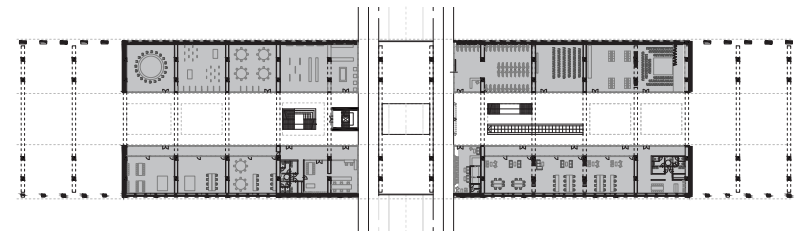

LINEARITY  
CONTINUITY

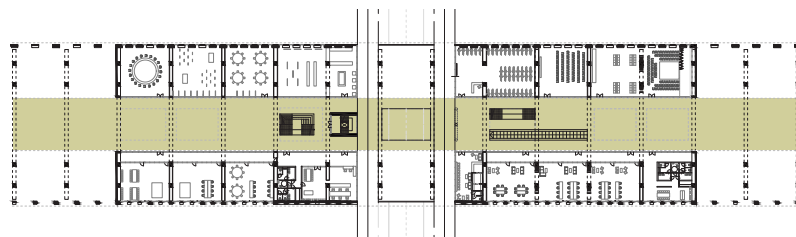

SHOUTING  
DOMINANT

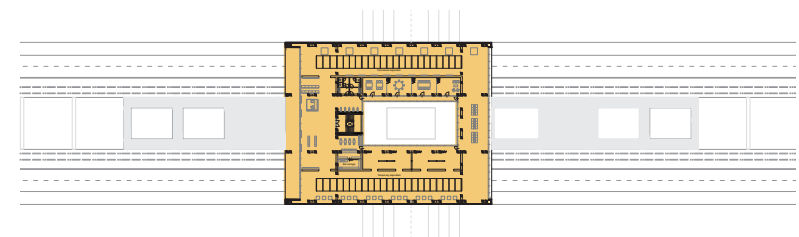



# 1. METAPHORS OF MOTION

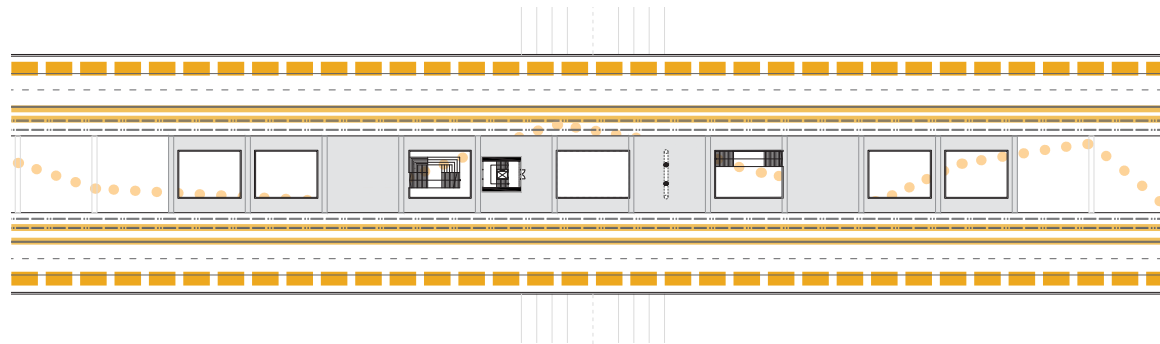



# MULTIPLE PERCEPTIONS OF MOTION

.....

## IN SECTION

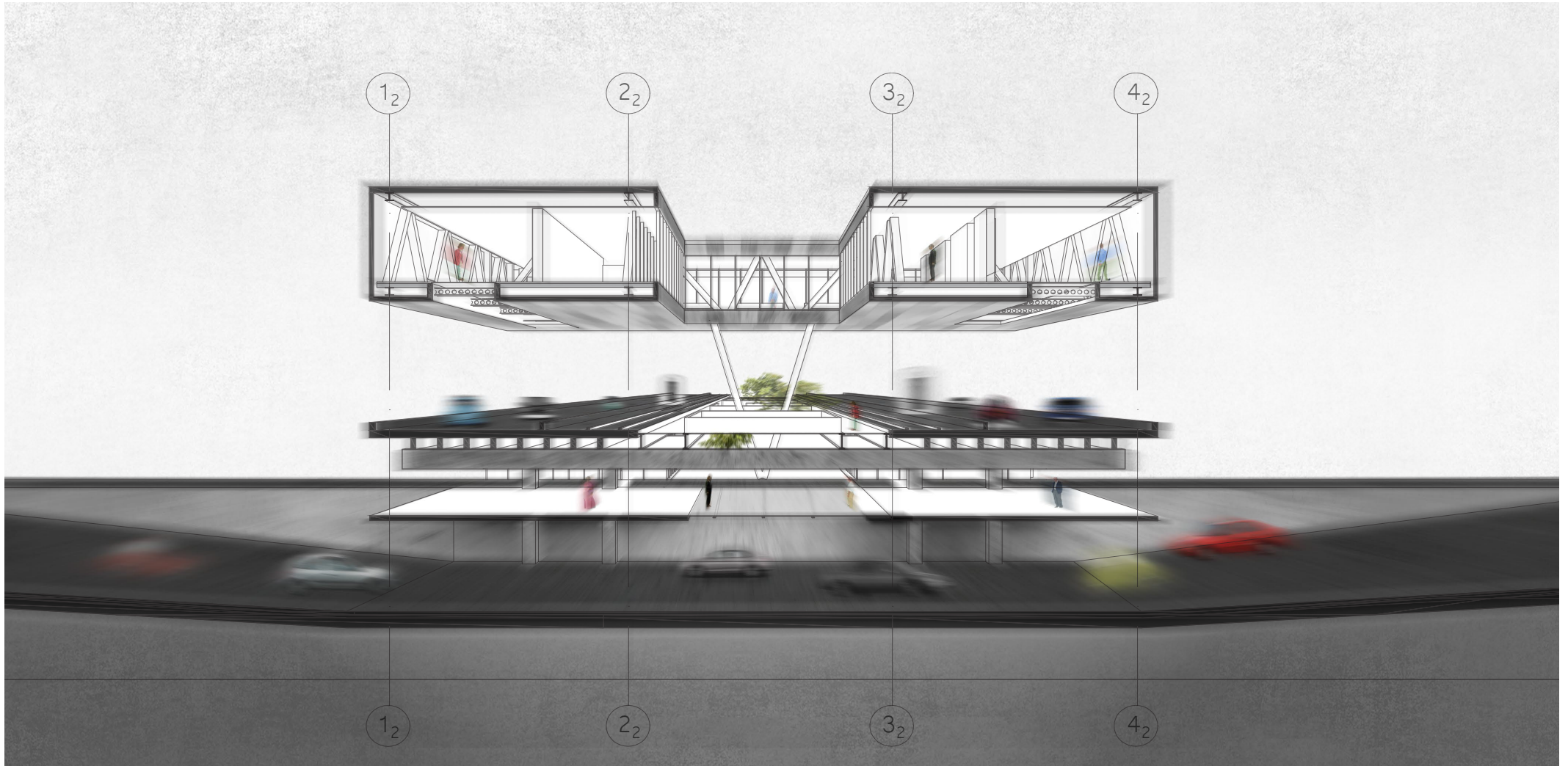



# MULTIPLE TYPES OF MOTION

IN PLAN

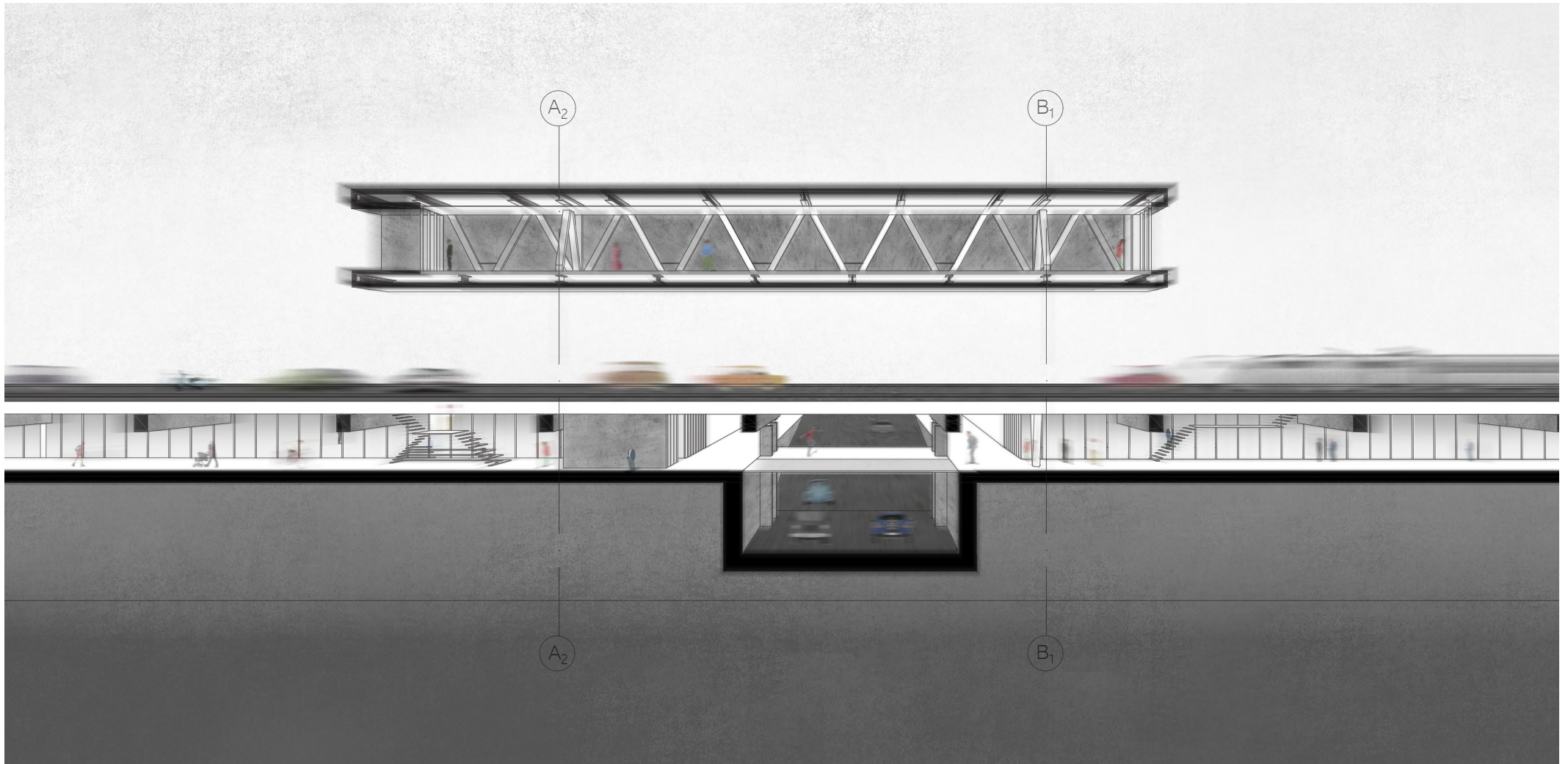

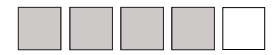

# UBIQUITOUS MOVEMENT

---





## 2. INTERNAL CHARACTER

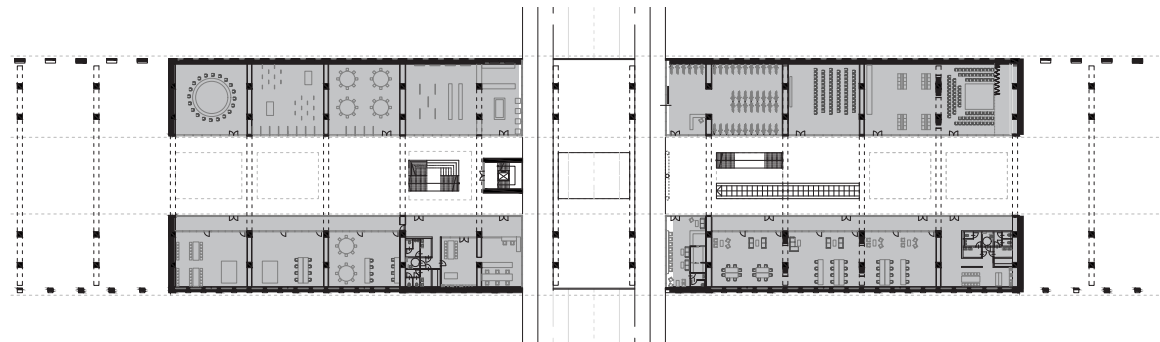

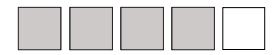

# INTERNAL CHARACTER

## SPATIAL ARRANGEMENT

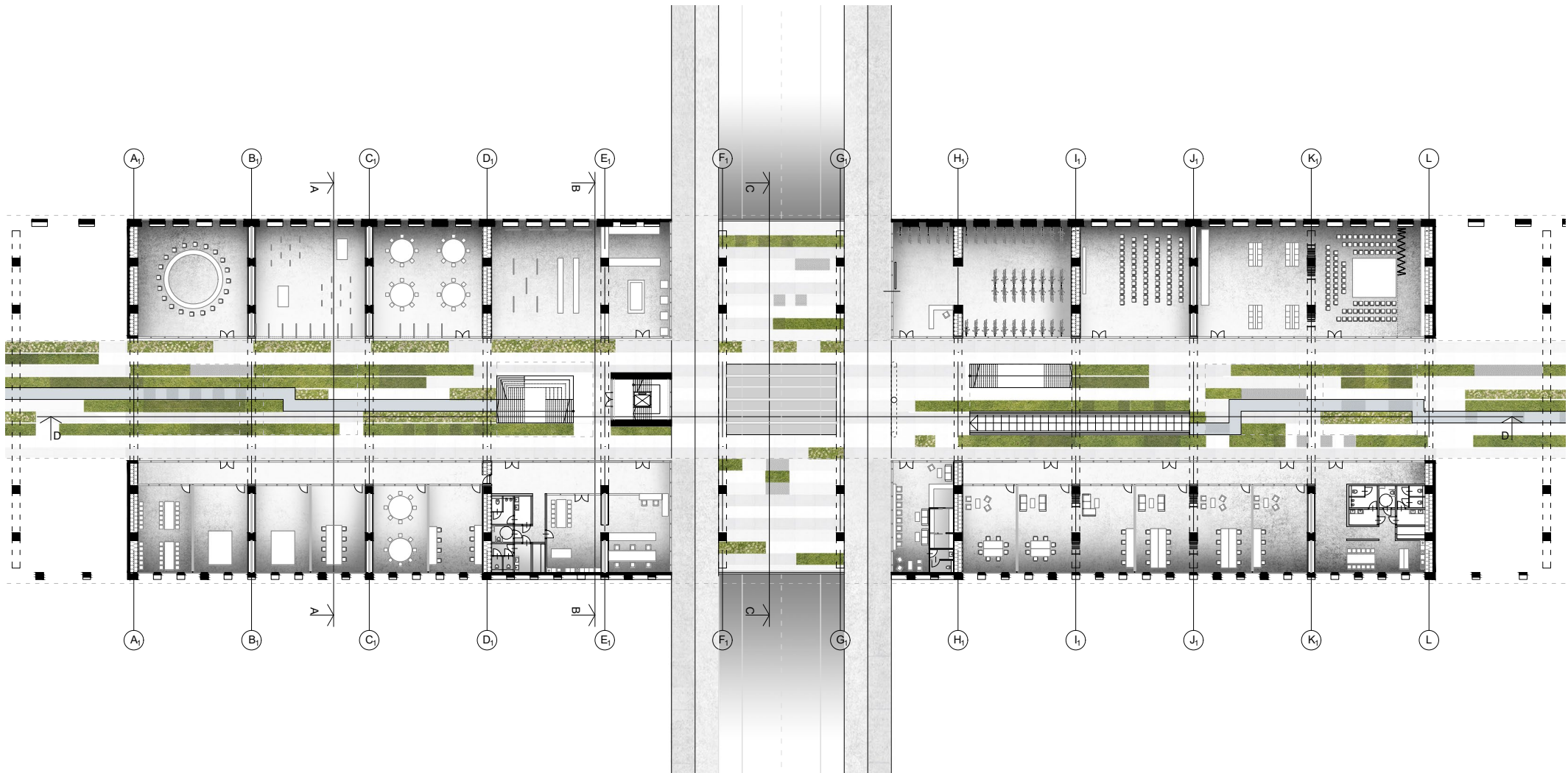



# INTERNAL CHARACTER

## SECTIONS





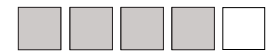

# INTERNAL CHARACTER

## USE OF THE FACADE





# INTERNAL CHARACTER

## MULTIFUNCTIONALITY OF THE FACADE BLOCKS



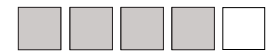

# INTERNAL CHARACTER

## ASSEMBLY SCHEME

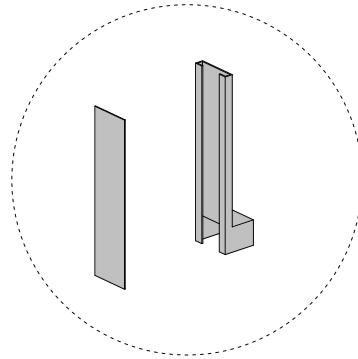

GFRC SHELLS

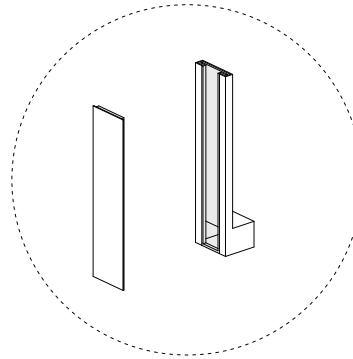

SPRAYED INSULATION

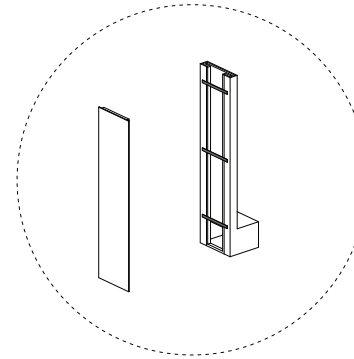

ATTACHING SYSTEM

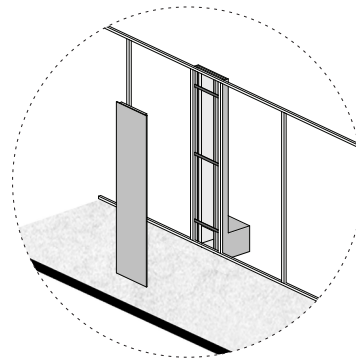

GLASS FACADE FRAME

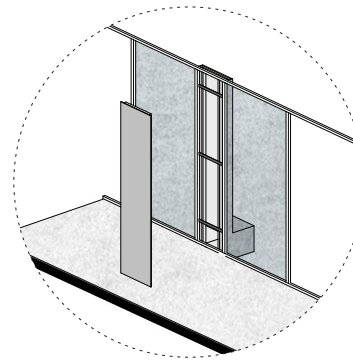

GLASS MONTAGE

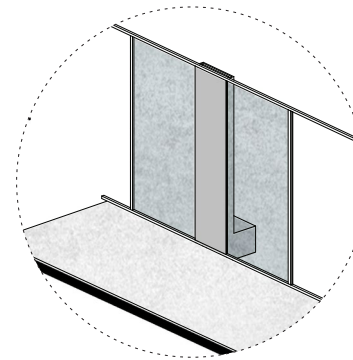

CLOSING THE PANEL



# INTERNAL CHARACTER

WEST AND EAST FACADE



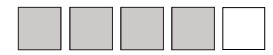

# INTERNAL CHARACTER

USE OF THE FACADE





# 3. LINEARITY & CONTINUITY

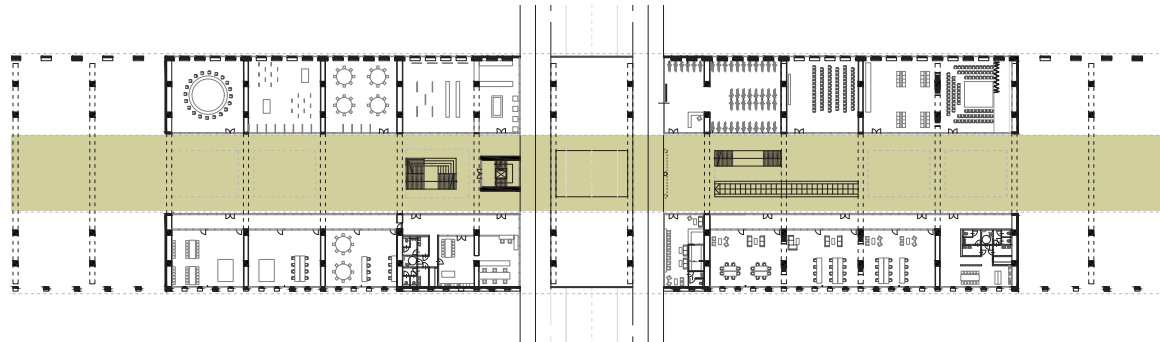



# LINEARITY & CONTINUITY

## PUBLIC GARDEN

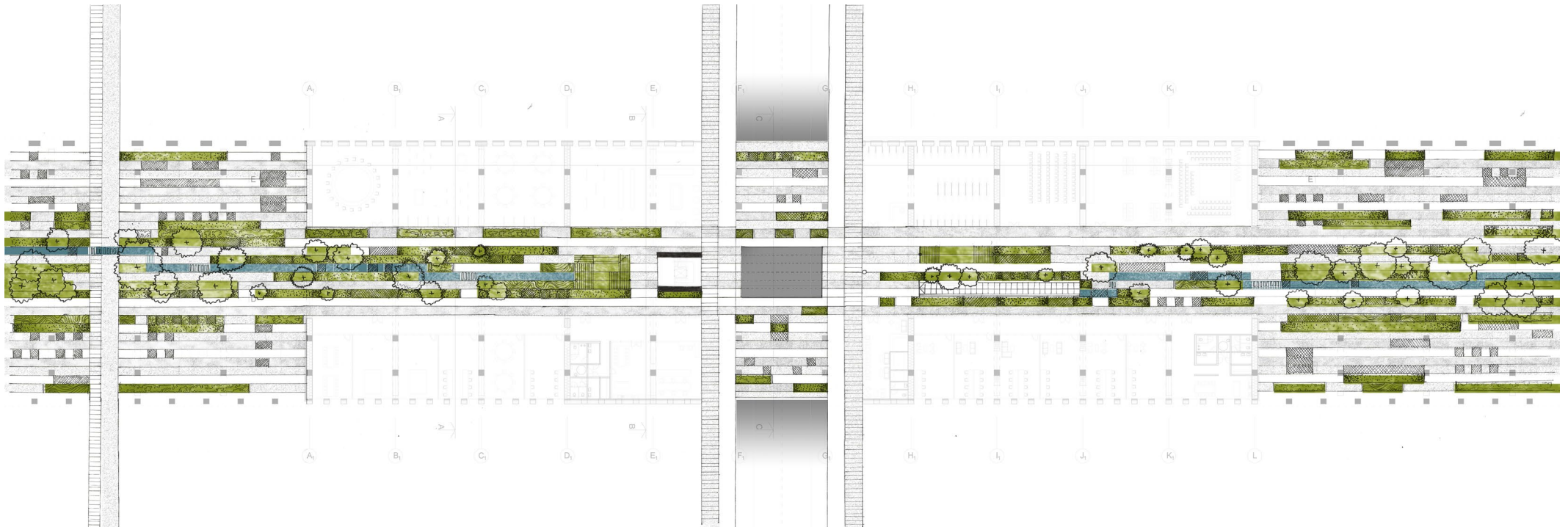



# LINEARITY & CONTINUITY

## SECTION OF THE PARK





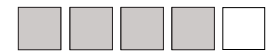

# LINEARITY & CONTINUITY

## SECTION OF THE PARK

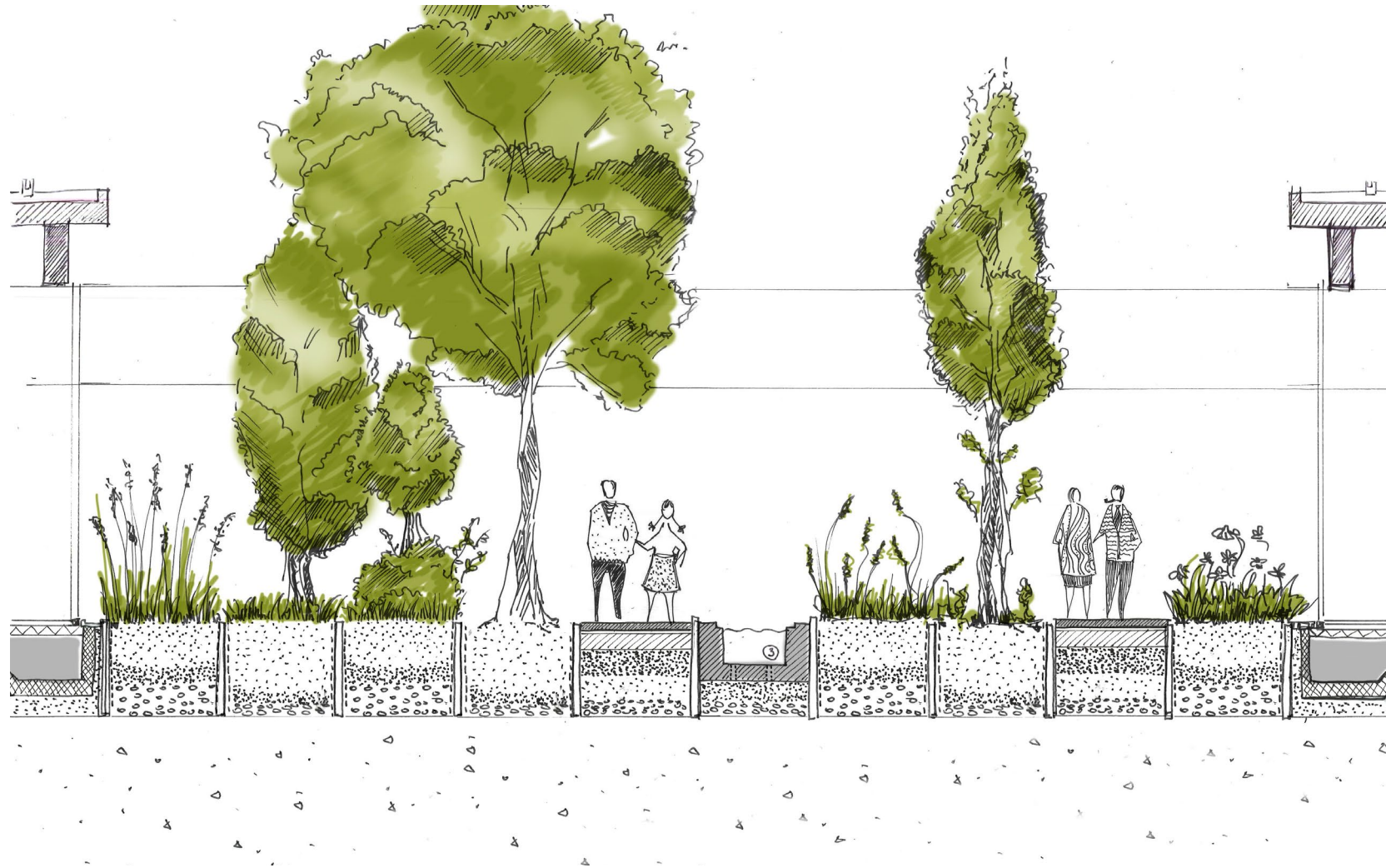

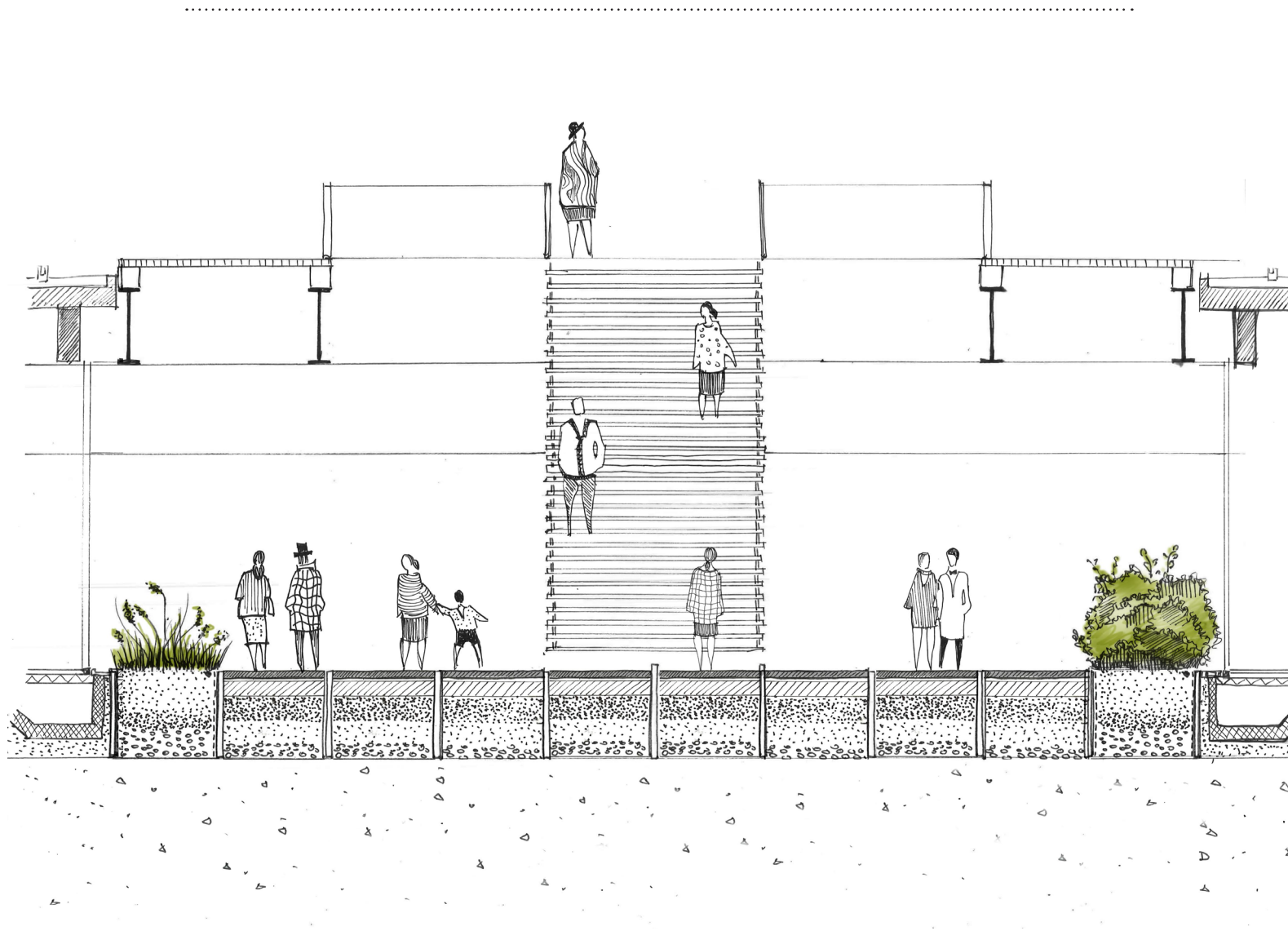



# LINEARITY & CONTINUITY

HANGING ELEMENTS - MINIMUM INTERRUPTION

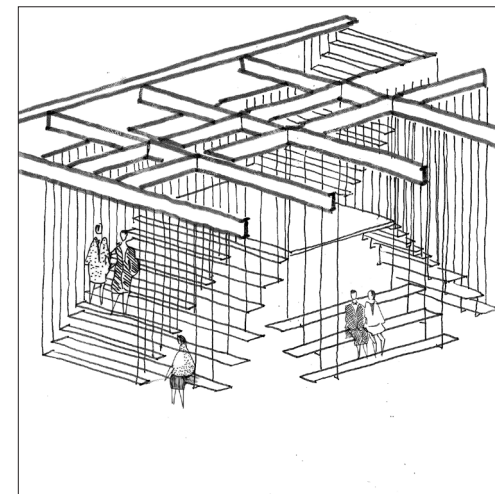
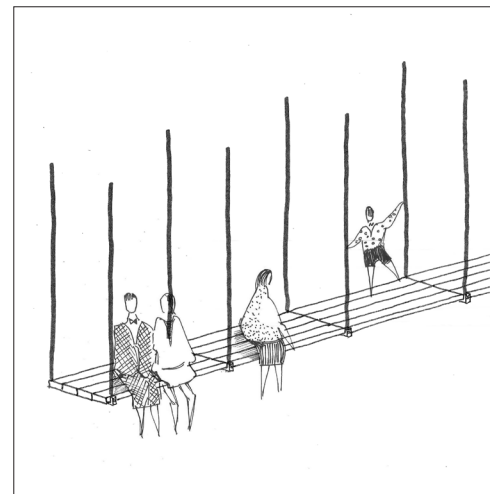
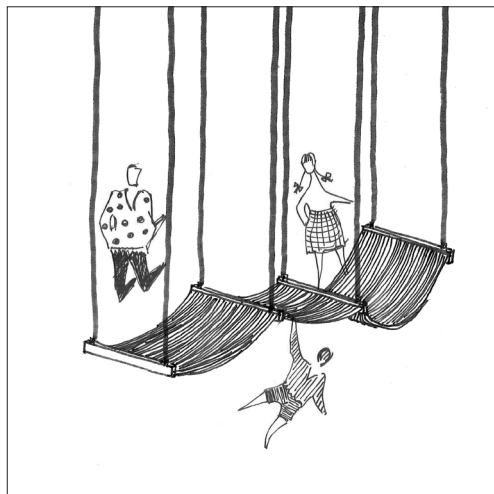
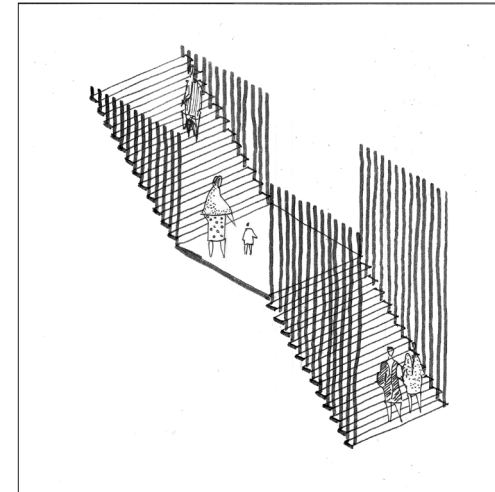
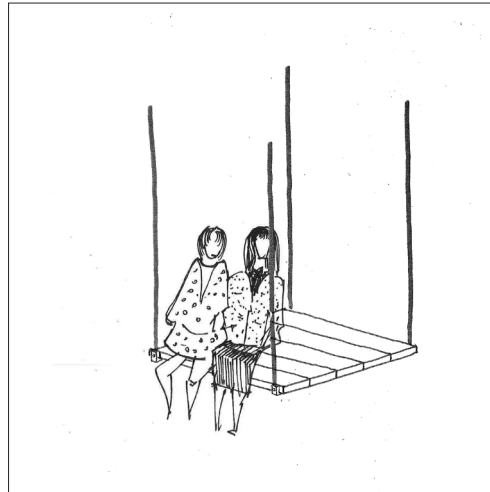
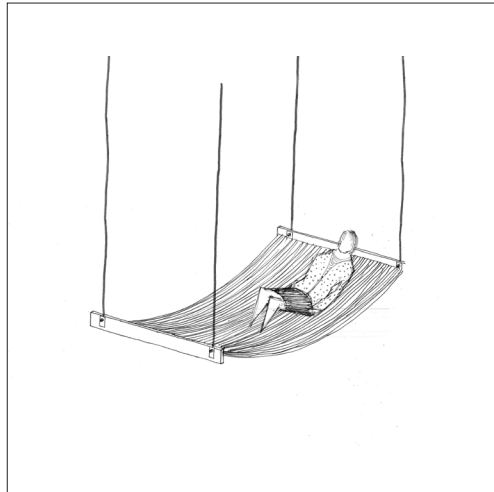



# LINEARITY & CONTINUITY

MAXIMUM INVISIBILITY

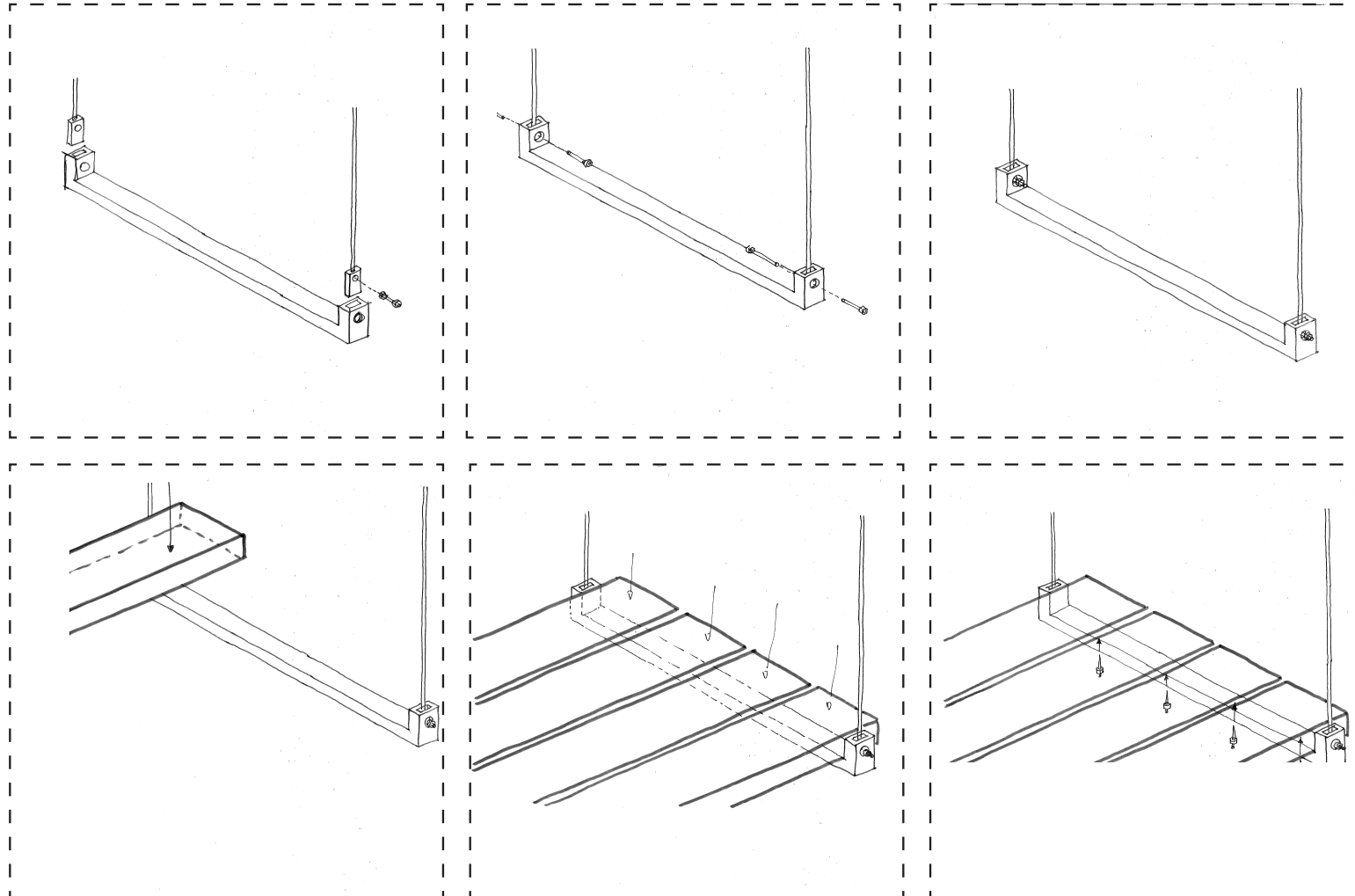

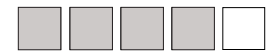

# LINEARITY & CONTINUITY

---

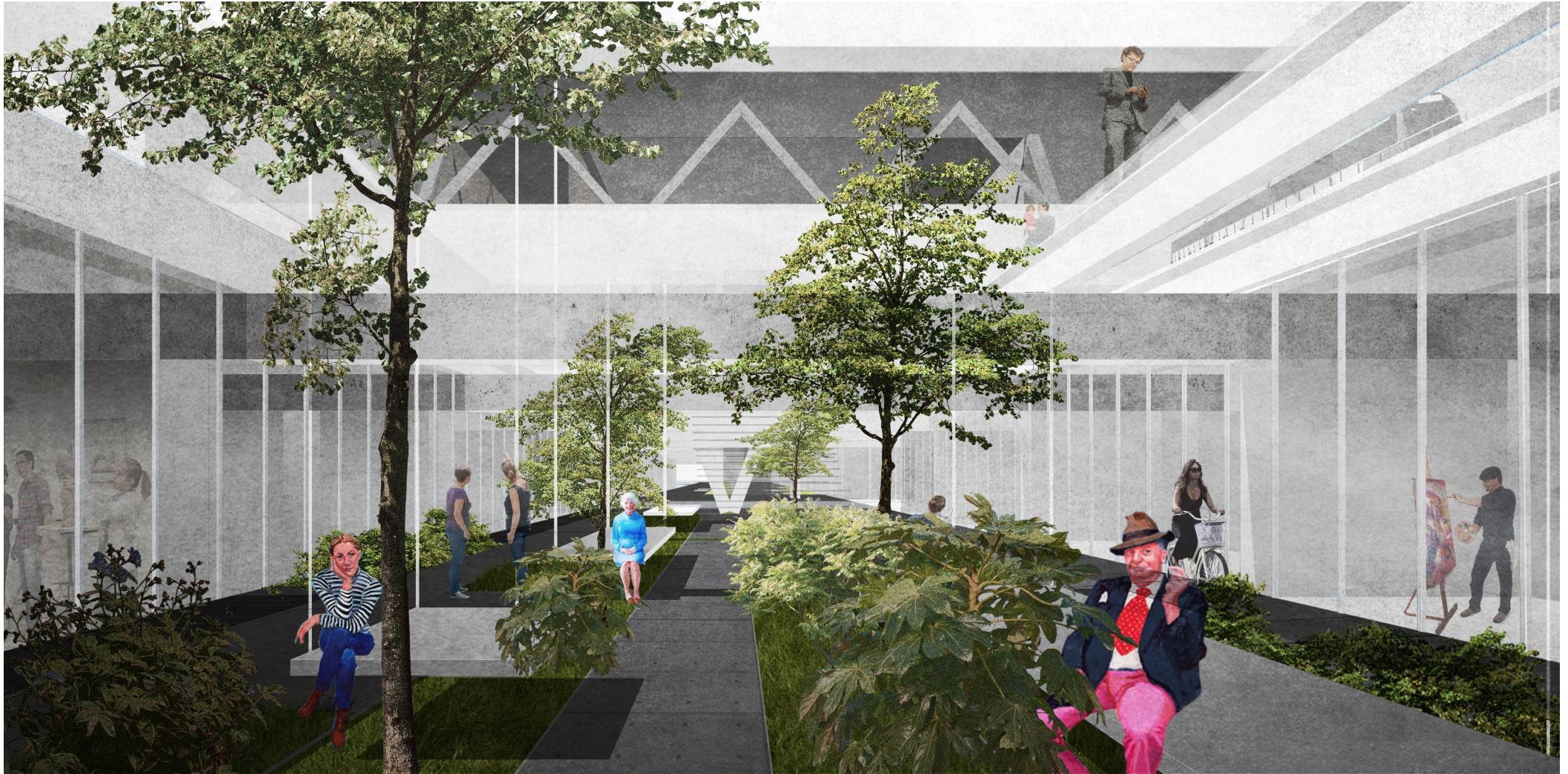



## 4. SHOUTING DOMINANT

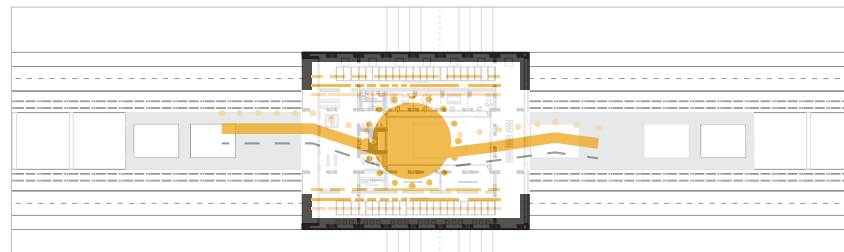

LINEARITY/  
CONTINUITY

INTERNAL  
CHARACTER

UBIQUITOUS  
MOTION

SHOUTINESS



# SHOUTING DOMINANT

## FORM TESTS





# INTERNAL CHARACTER

## SPATIAL ARRANGEMENT

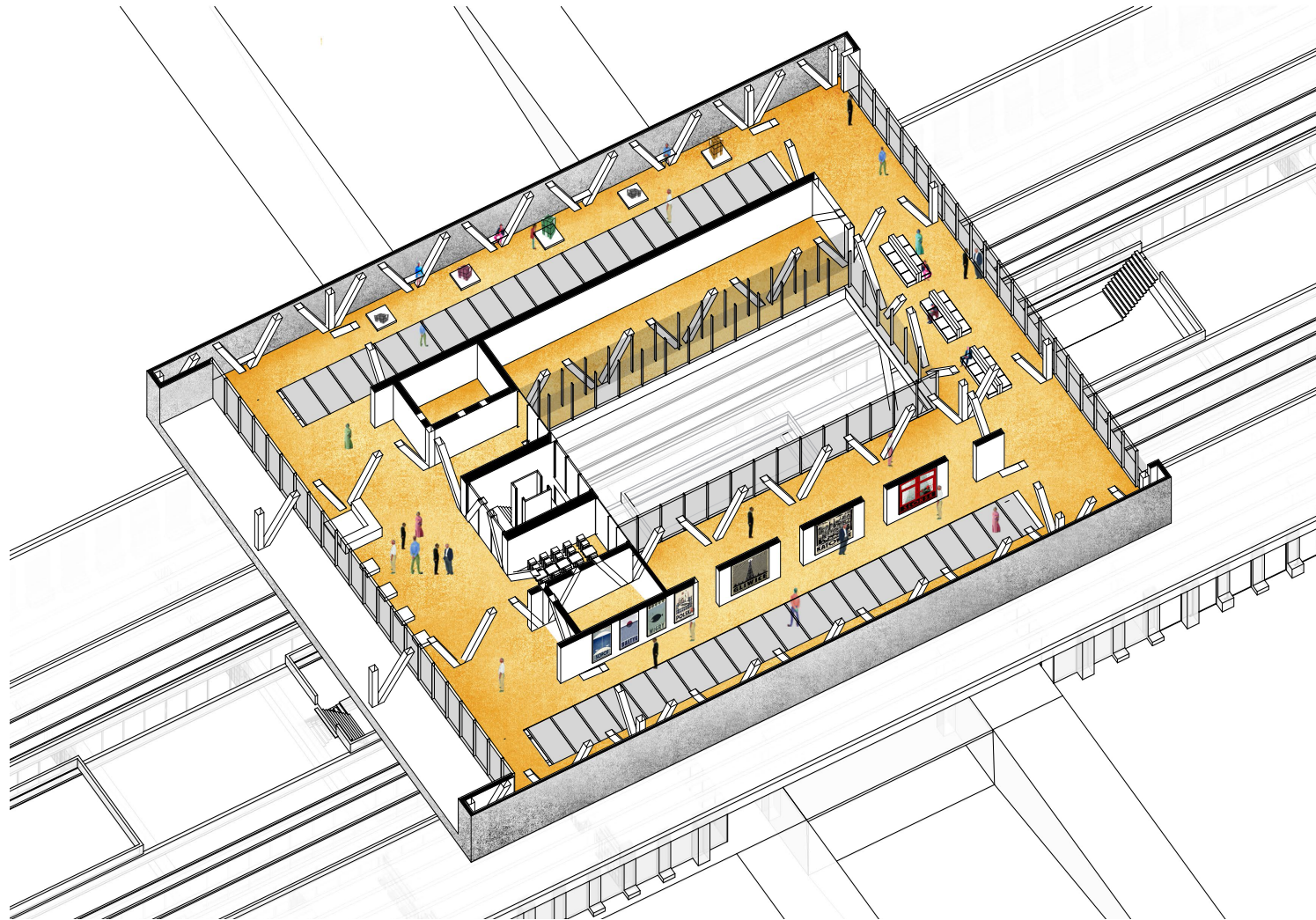



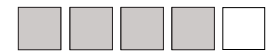

# CONTINUOUS PERCEPTION OF MOTION

TRAFFIC AS PART OF THE EXHIBITION



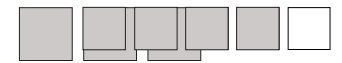

# CONTINUOUS PERCEPTION OF MOTION

REFLECTION ZONE





# MATERIALIZATION

ABSTRACT MODELS STUDIES





# THOUSANDS FACES OF CONCRETE

---

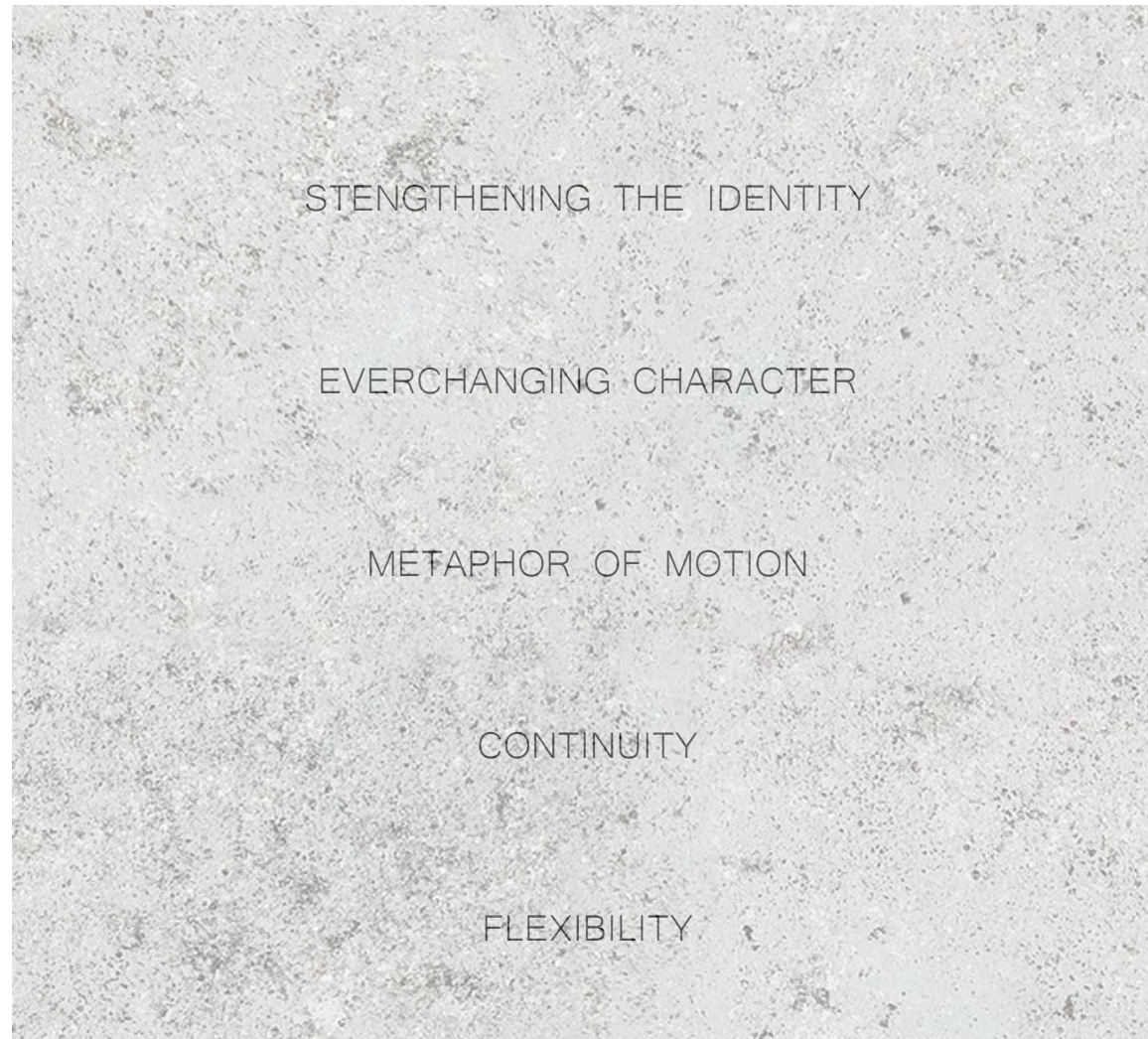

# MATERIAL STUDIES

---

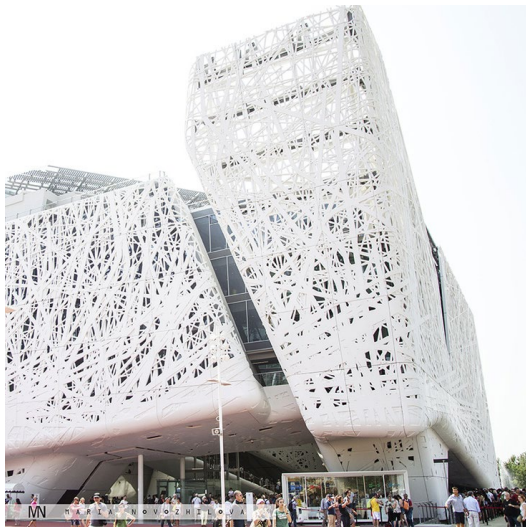

SMOG EATING CEMENT  
i.Active Biodynamic



TRANSLUCENT CONCRETE

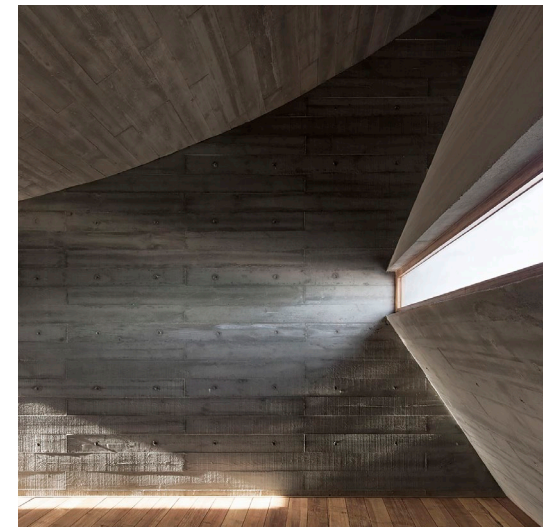

CAST IN SITU CONCRETE



# CONCRETE TESTS

---



# CONCRETE TESTS

## LIGHT TESTS

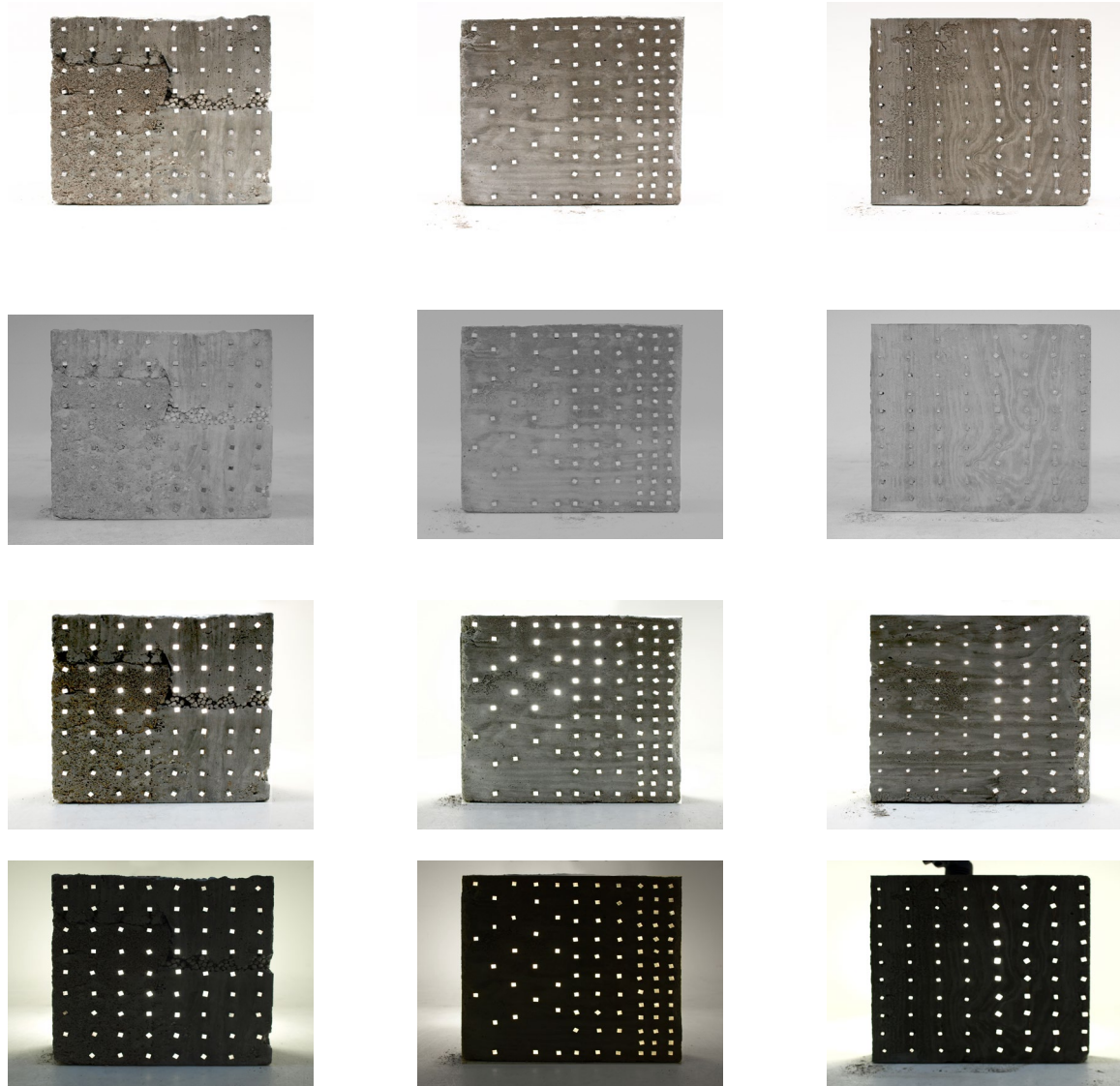



# METAPHOR OF MOTION & LINEARITY

---

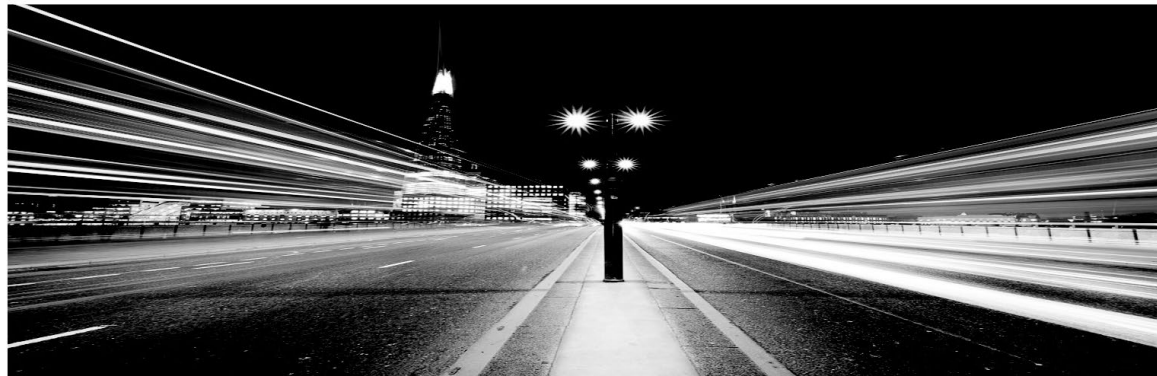



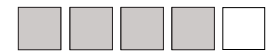

# METAPHOR OF MOTION

## FACADE STUDIES

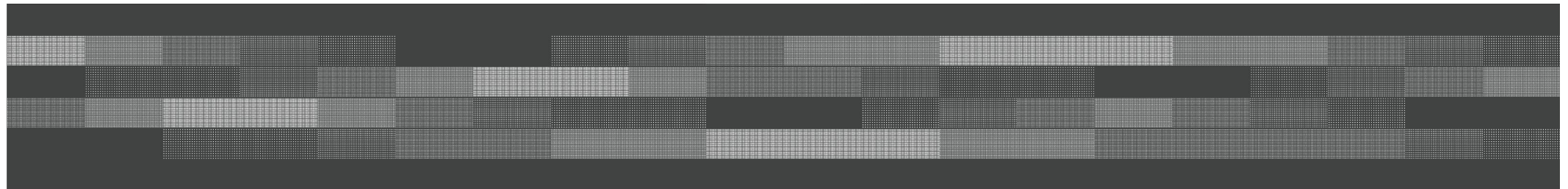
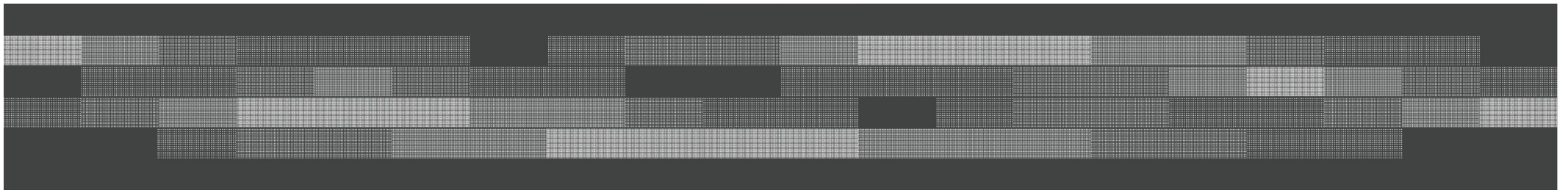
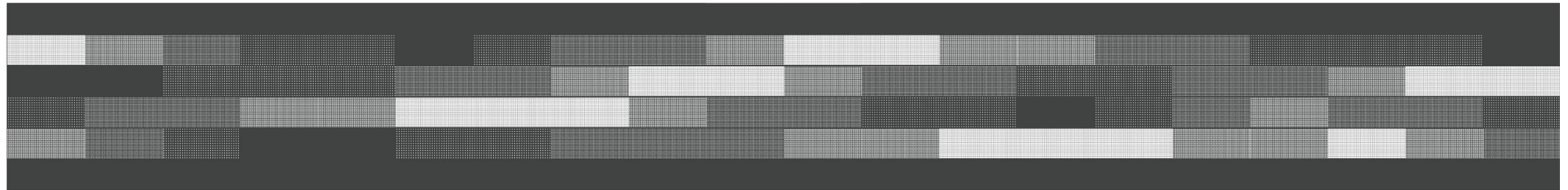
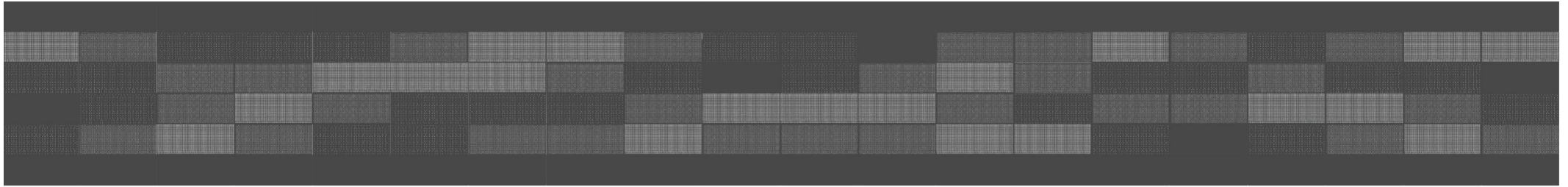



# SYSTEM OF CONCRETE SANDWICH PANELS

## DIFFERENT TRANSLUCENCY

PANEL 1  
spikes grid  
40mmx40mm

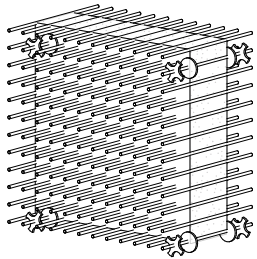

PANEL 2  
spikes grid  
50mmx50mm

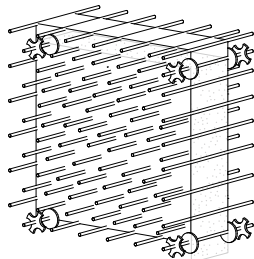

PANEL 3  
spikes grid  
60mmx60mm

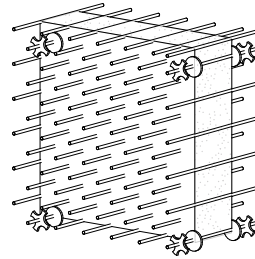

PANEL 4  
spikes grid  
70mmx70mm

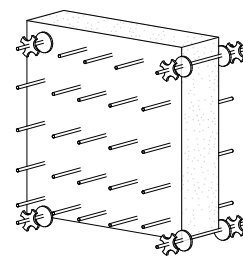

PANEL 5  
spikes grid  
90mmx90mm

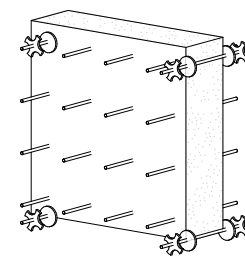

PANEL 6  
no spikes

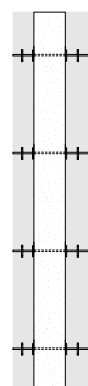
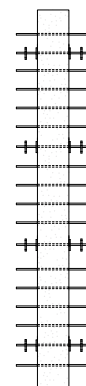
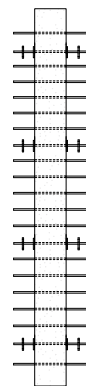
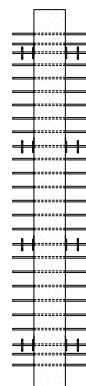
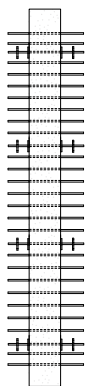
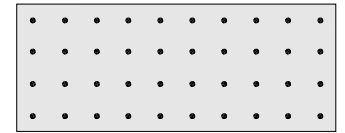
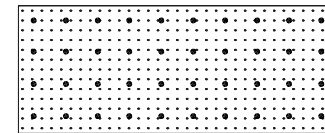
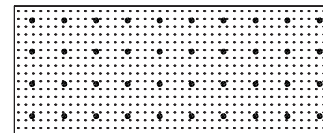
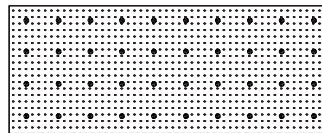
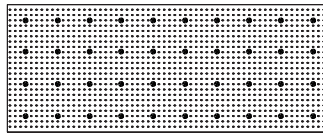
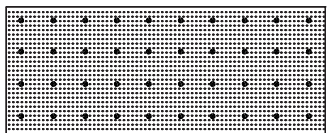
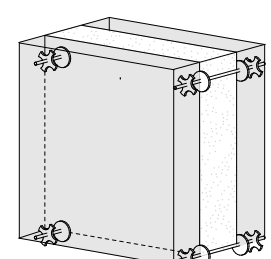



# FACADE DURING THE DAY

---





# FACADE DURING THE NIGHT

---

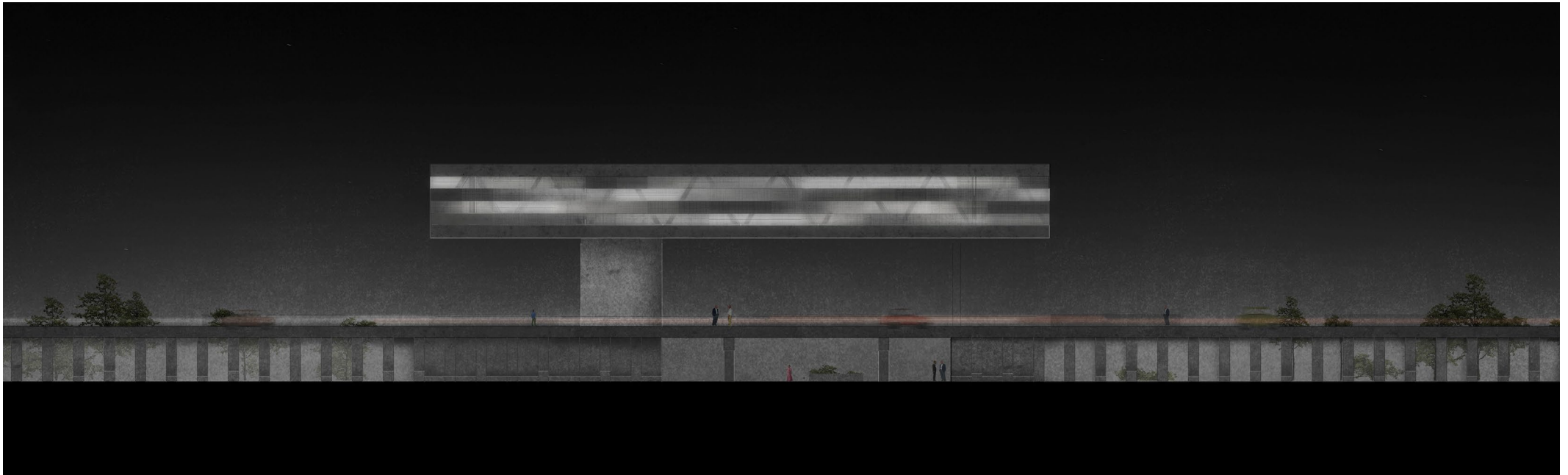

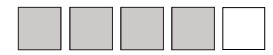

# CONTINUITY IN DETAIL

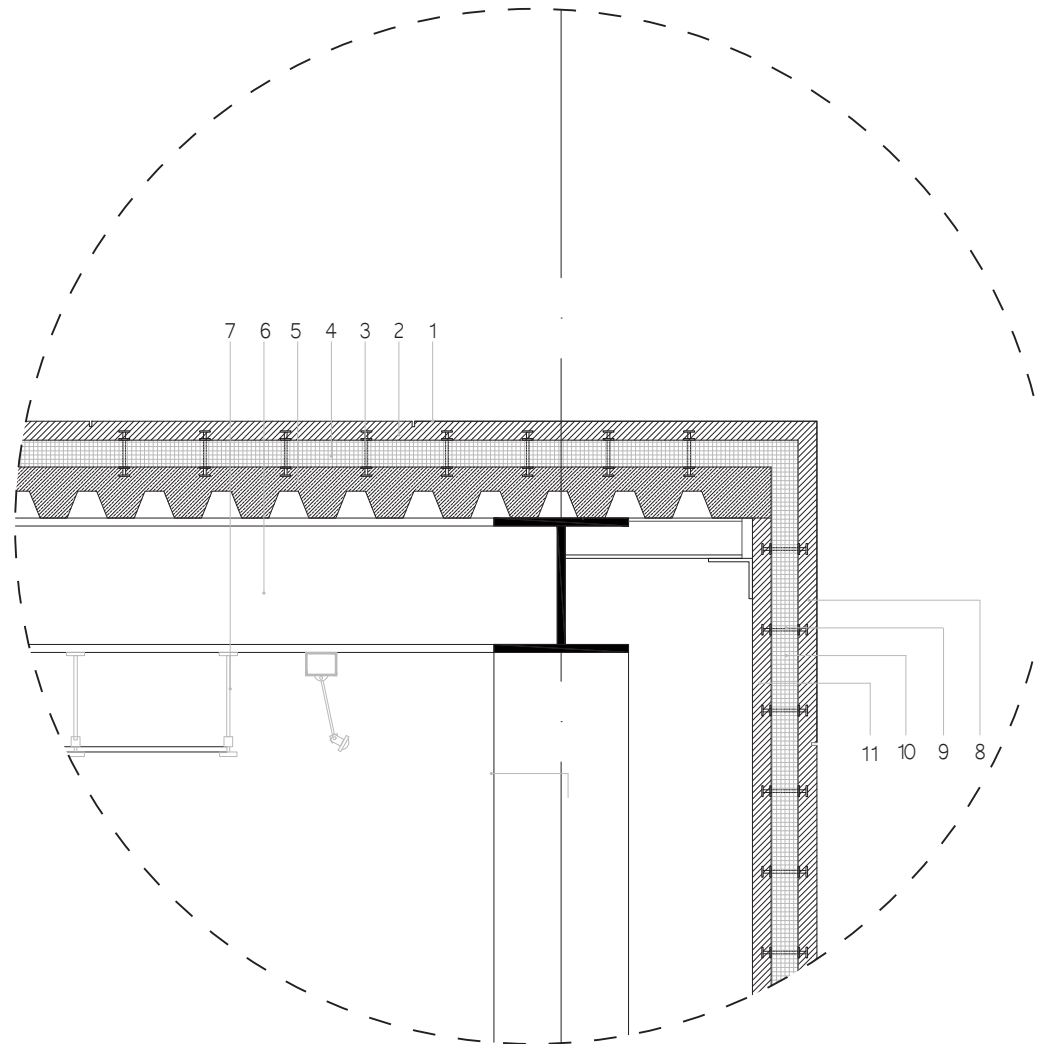

1. concrete waterproofing membrane
2. concrete 70mm
3. fiber reinforced concrete connector
4. XPS insulation 100mm
5. composite slab 200mm
6. steel beam 500mm
7. suspended ceiling 300mm
8. concrete 70mm
9. fiber reinforced concrete connector
10. XPS insulation 100mm
11. concrete 70mm

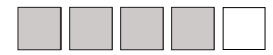

# CONTINUITY IN DETAIL

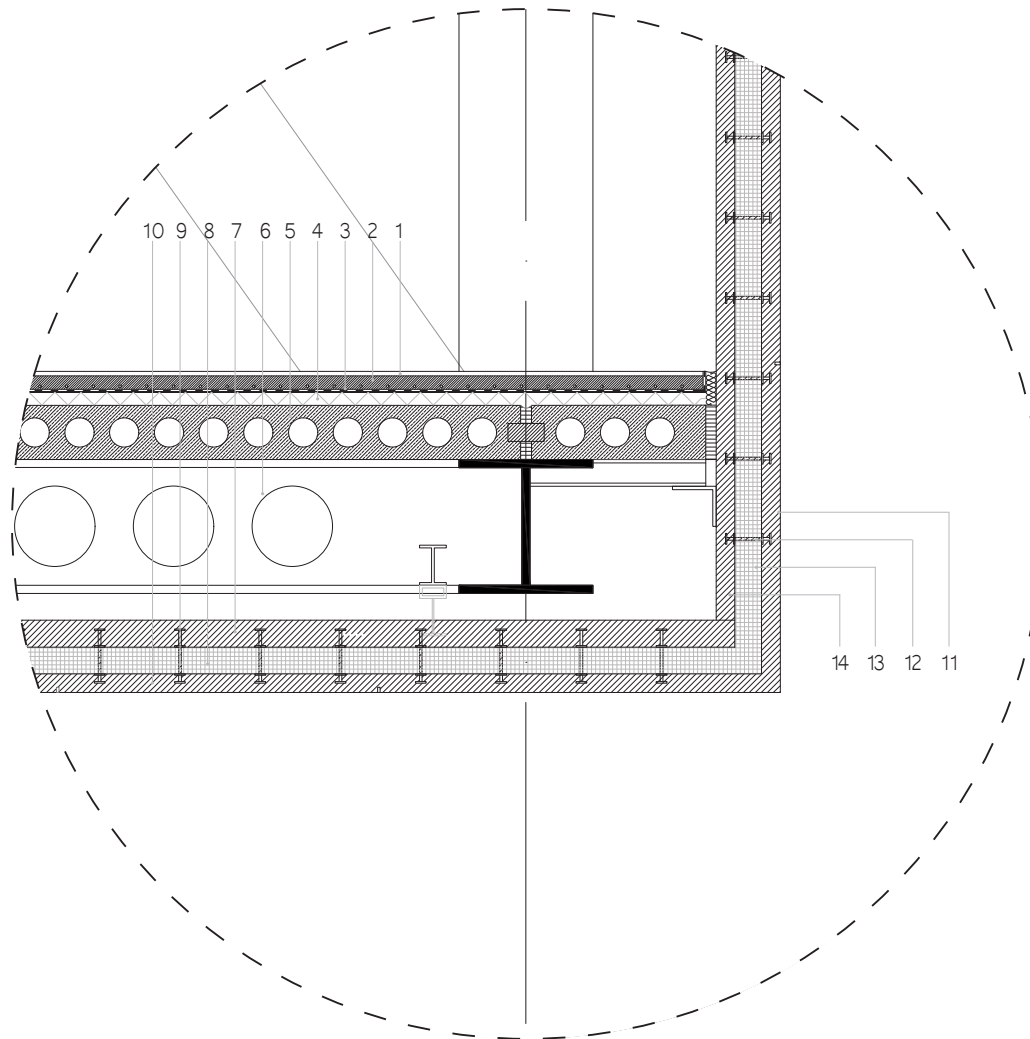

1. Resin concrete floor 15mm
2. Creed + underfloor heating system pipes 65mm
3. Waterproof insulation
4. Hardstyrofoam 50mm
5. Prefabricated slab 200mm
6. Steel beam 500mm
7. Poured concrete reinforced with metal mesh 100mm
8. XPS insulation 100mm
9. Fiber reinforced concrete connectors
10. Poured concrete 70mm
11. Concrete 70mm
12. Fiber reinforced concrete connector
13. XPS insulation 100mm
14. Concrete 70mm

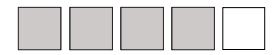

# CONTINUITY IN THE BUILDING PERFORMANCE

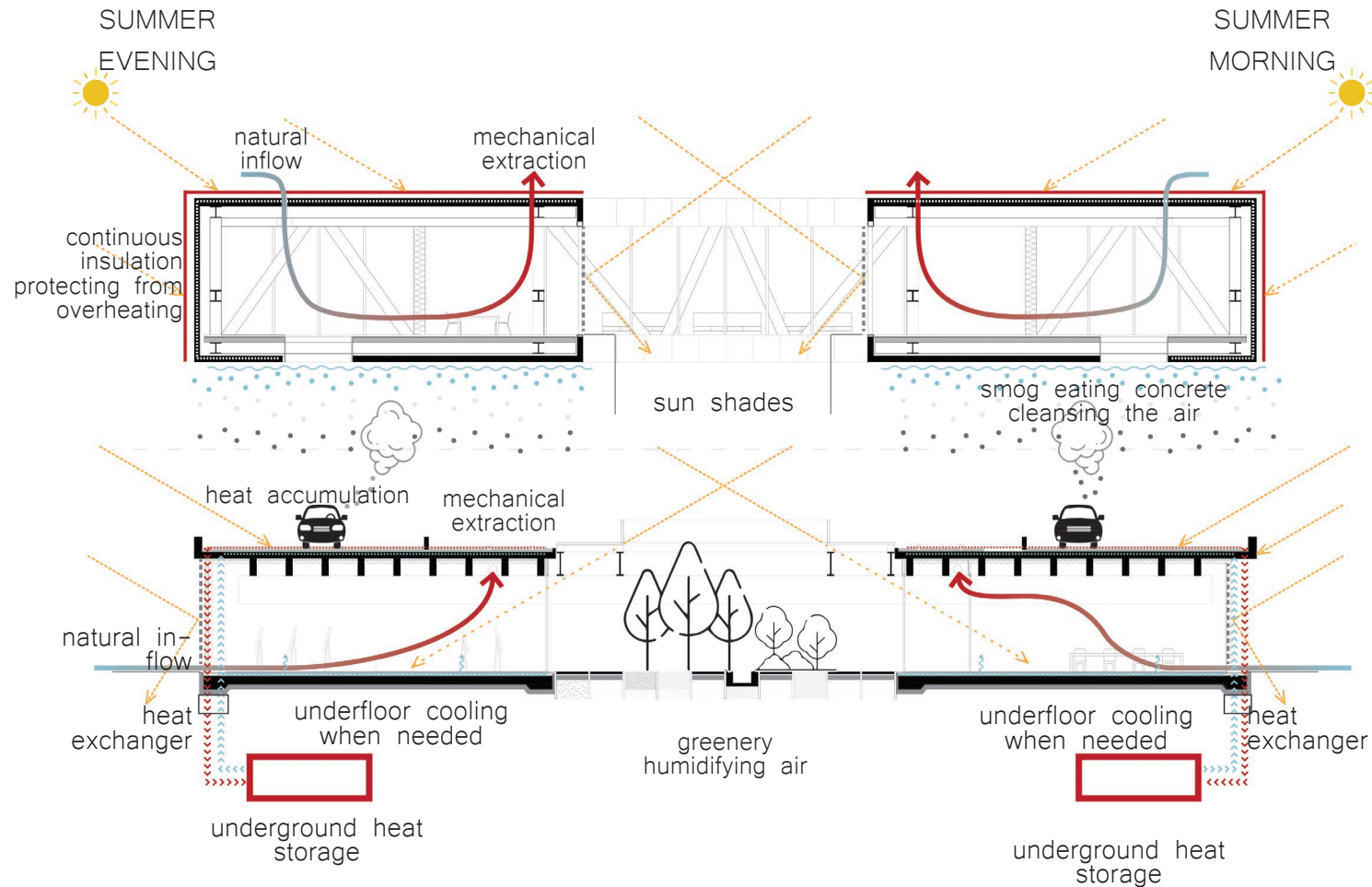

# CHAPTER IV



Reflection





REFLECTION

# REFLECTION

---

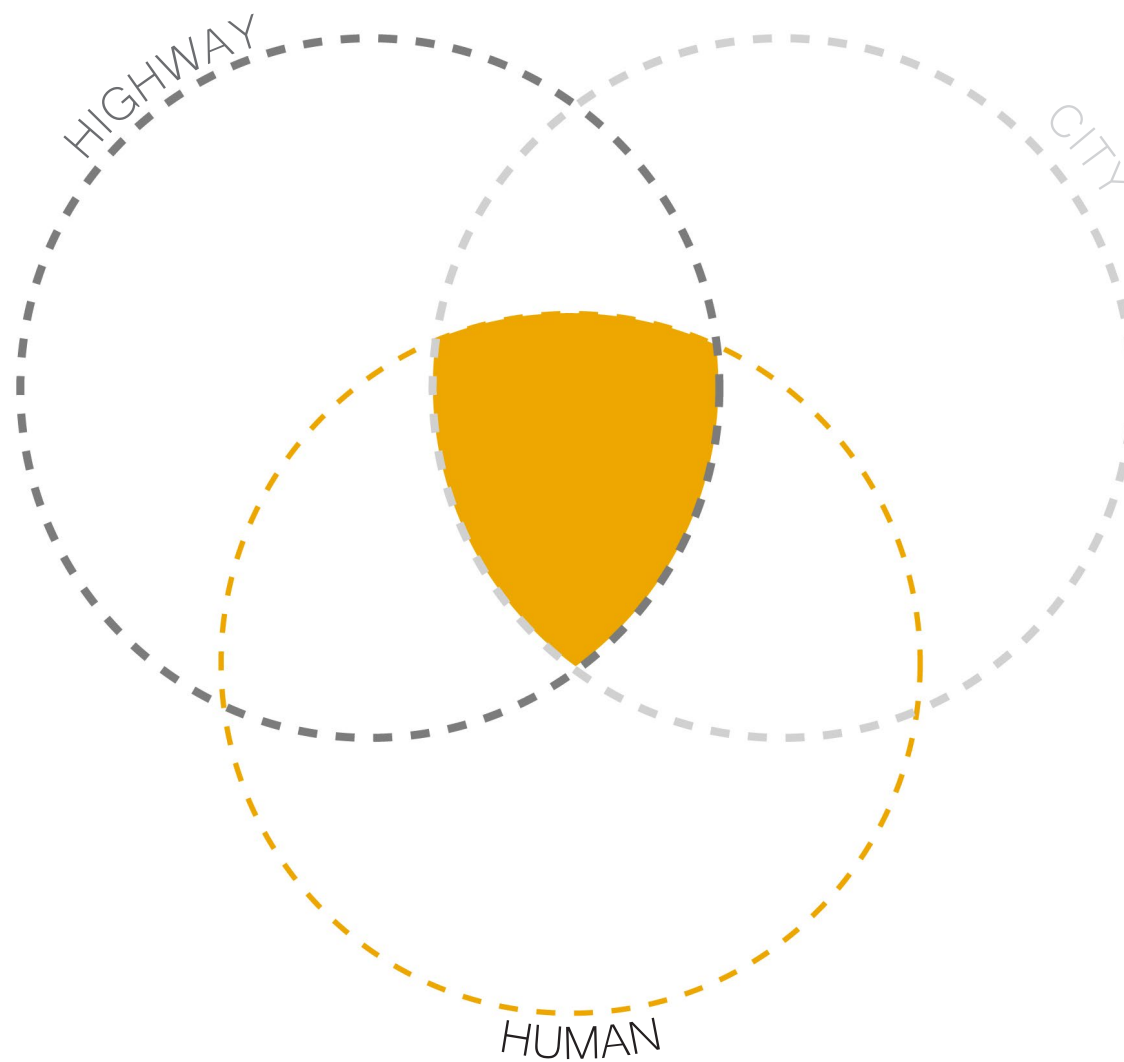



REFLECTION

# REFLECTION

---

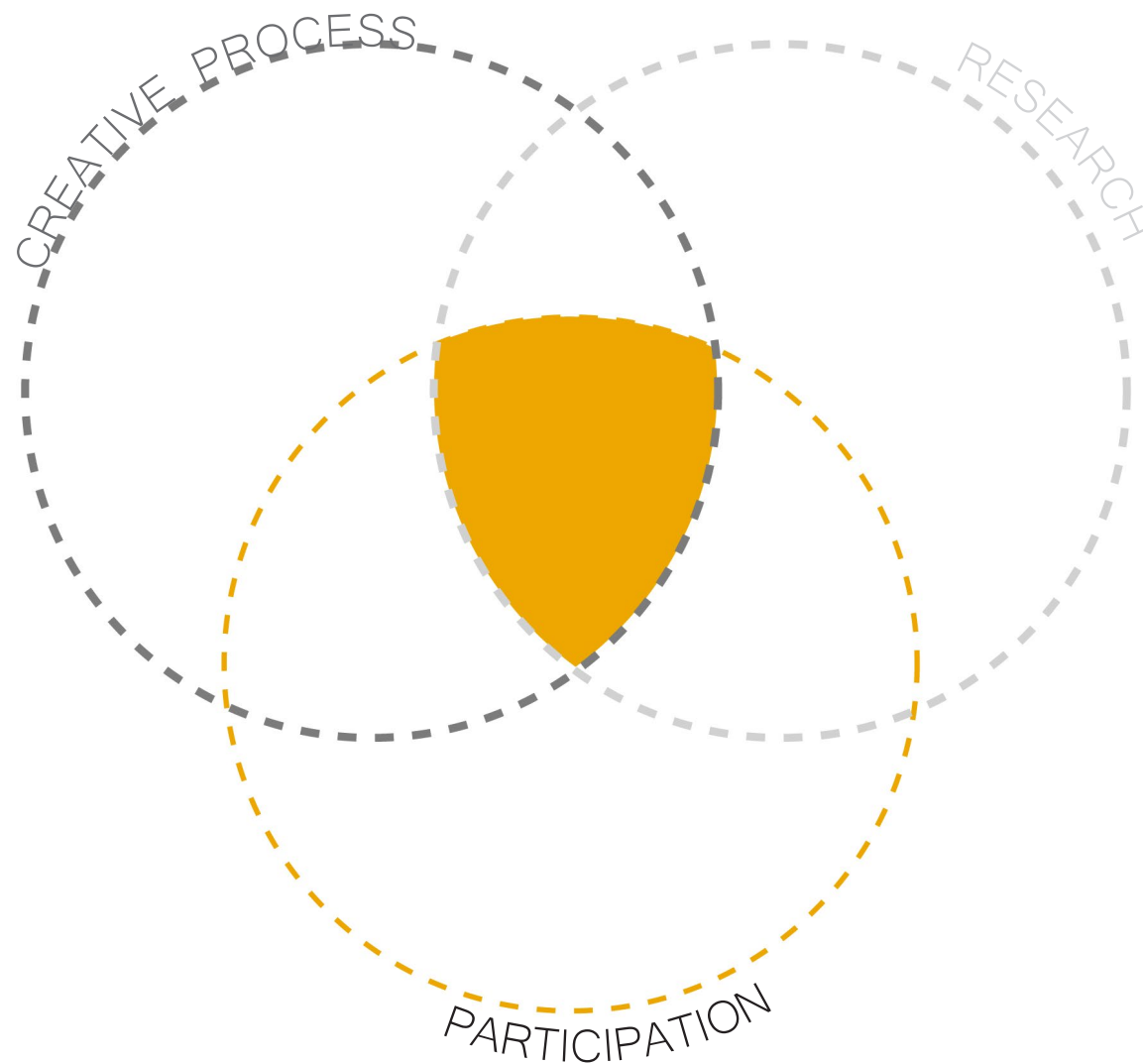



# SHOUT - OUTS

## PARTICIPATORY RESEARCH

- Klaas van Olphen
- Yafim Simanovski
- Jan Ksiazek
- Olivier Boright
- Jakub Jekiel
- Andreas Root
- Quita Schabracq
- Alexandra Mirou
- Claudiu Lionte
- Michel Couzy
- Bart Nauta
- J. Bras
- Pim Burgers
- Dawid X
- Fallon Walton
- Jesse Willis
- Fokke Jongerden
- Roel Jongerden
- Pacome Rsnn
- Lisa van Beek
- Federico Riches
- Koen Fraijman
- Fadime Gökkaya
- Damen Ton
- Jesse's mum
- Huib van Zeijl
- Brigitte O'Regan
- Hanneloes Pen
- Esther Reith
- Florian Nelemans
- Danielle Segers
- Ola gordowy
- Ania Bozek
- Rosa Stapel
- Marc Kruyswyk
- Veronique Ten Holter
- Jan Fraijman
- Betty

## PARTICIPATORY DESIGN

- Marta Szczepanska
- Kevin Gunawan
- Margot De Man
- Ola Gordowy
- Kuba Lewicki
- Rafal Tarczynski
- Edyta Milczarek
- Chloe Eersel
- Matteo Santangelo
- Zbigniew Nalepa
- Maria Nalepa
- Alfreda Podlacka
- Jakub Jekiel

## MULTIDISCIPLINARY CONSULTS

- Olindo Caso (First mentor)
- Hubert van der Meel (Second mentor)
- Franklin van der Hoeven (Third mentor)
- Dave Wendt
- Rosa Stapel (urbanist)
- Jeroen van der Hoek (Structure advisor)
- Christien Janssen (Climate advisor)
- Mark Minkjan (Arcam)
- Arthur Perdijk (Artist)
- Hans de Boer (Architect)
- Rients Dijkstra (Government avisor)
- Johannes Langer (Urbanist)
- Esther Reith (MUNICIPALITY OF AMSTERDAM)
- Pieter Bannenbergh (NL ARCHITECTS)
- Huib van Zeijl (EQUIPE)
- Daniëlle Segers (EQUIPE)
- Laura Groenendijk (GOUDAPPEL)
- Maurice Harteveld (AMS INSTITUUT)
- Jurriaan Hillerstrom (NEXT ARCHITECTS)
- Lars van Hoften (UN STUDIO)
- Ton Venhoeven (VENHOEVEN CS)
- Rene Boers (FAILED ARCHITECTURE)
- David Ten Napel (ARCAM)
- Stefan Bendiks (ARTGINEERING)

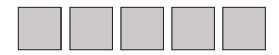

REFLECTION

# THANK YOU

---

