

HOMES THAT WORK

THE ARCHITECTURE FOR HOME WORKING PARENTS
AND CHILDREN IN AN URBAN CONTEXT

TUTORS:

Theo Kupers
Ferry Adema
Anne Kockelkorn
Pierijn van der Putt

DELEGATE

Paul Chan

PRESENTATION BY

Karwan Omar

Date 10/01/2022

1. Design Location

2. Research Topic

- Urban families
- Live / Work

3. Design

DESIGN LOCATION



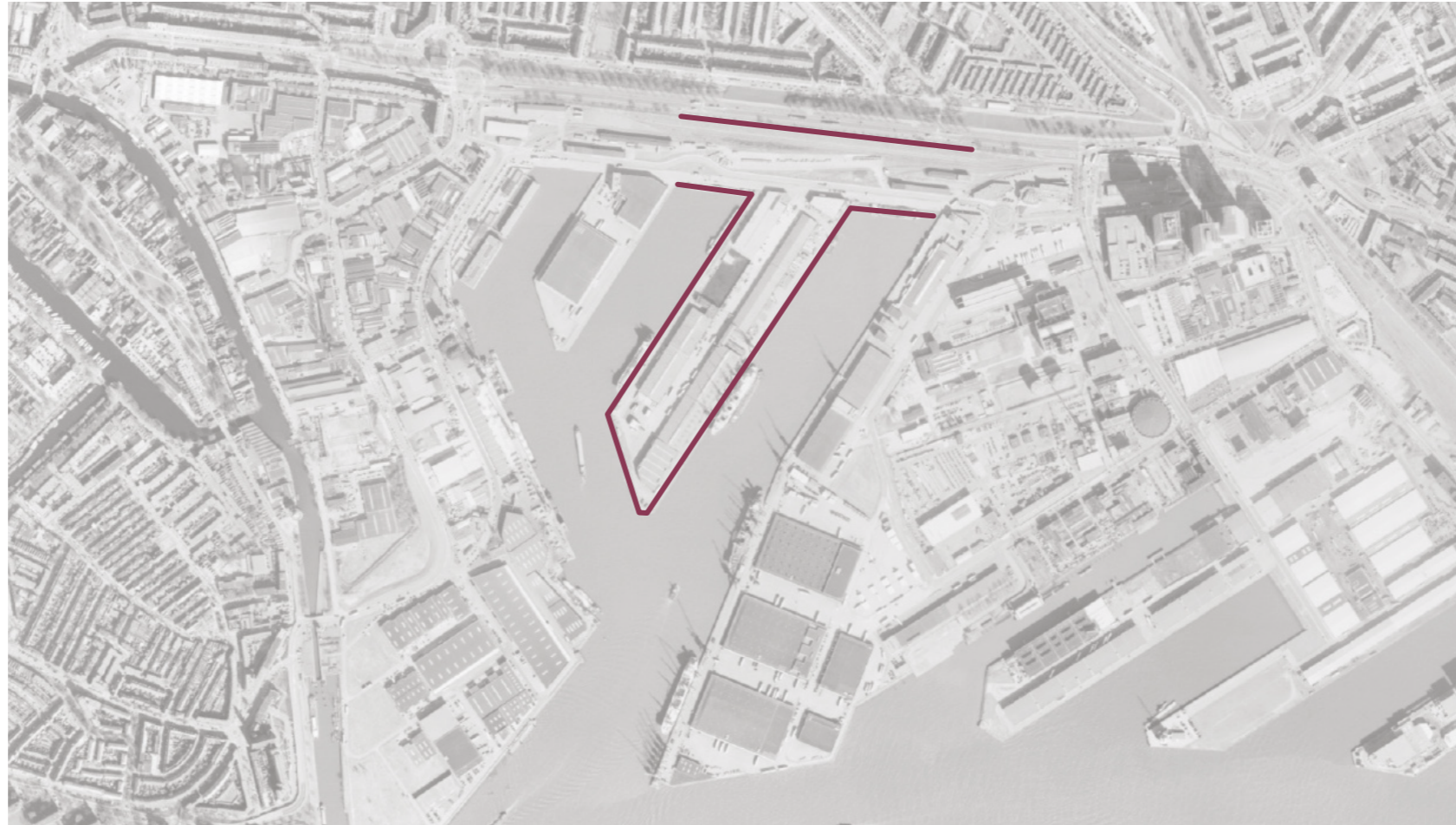





RESEARCH TOPIC

Urban families



Living and working from home
with children



Reasons:



Dwelling size



Affordability



Lack of outdoor space



Safety



Heavy traffic

Design principles for Urban families

Neighborhood



Safety



Outdoor space



No/Low Traffic



Play garden



Day-care



Other families



Café & Supermarket



Schools

Building

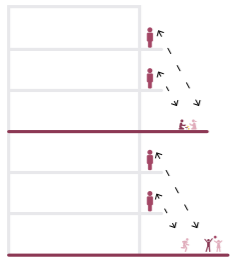

Max. 03 level height difference for supervision

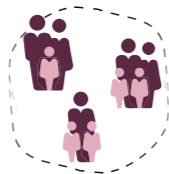

Clustering families and sharing care tasks

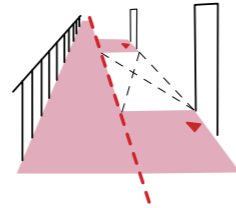

Dual-use of space

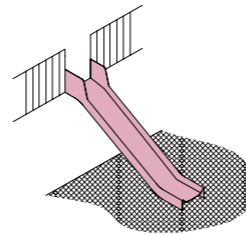

Connect levels playfully

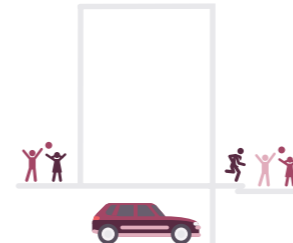

Space for play instead of parking

Dwelling

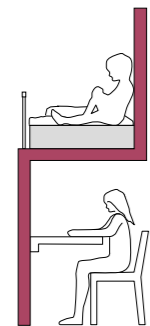

Adaptability of spaces

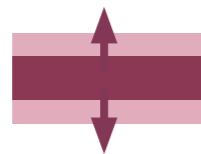

Oversized hallway for work, play and supervision

Range of action

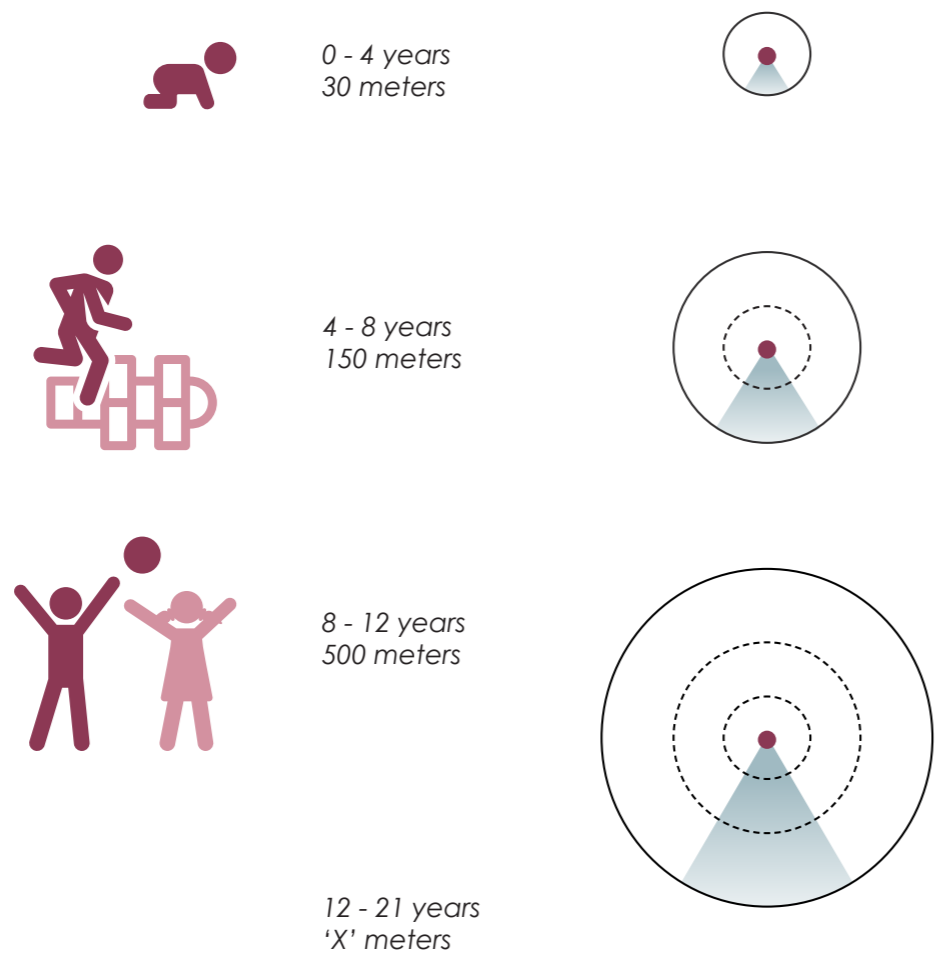

Supervised

Unsupervised

Accomodate all characters of children



Urban families



Living and working from home with children



The workhome was the norm in many shapes and forms all over the world, until the industrial revolution



Separation of live/work



Future of home-based work?

MEDIEVAL

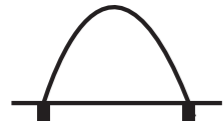

Longhouse

MEDIEVAL

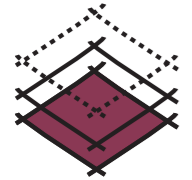

Townhouse

MEDIEVAL



Merchant's house

MEDIEVAL



Manor house

19TH CENTURY

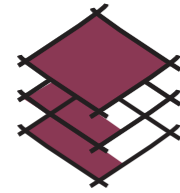

Top-shops

19TH CENTURY

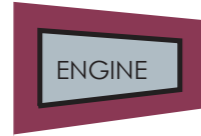

Cottage factory

19TH CENTURY

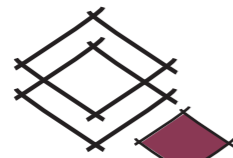

Knitters' cottages

19TH CENTURY

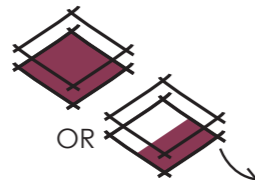

Shop-houses

OR
Small shops

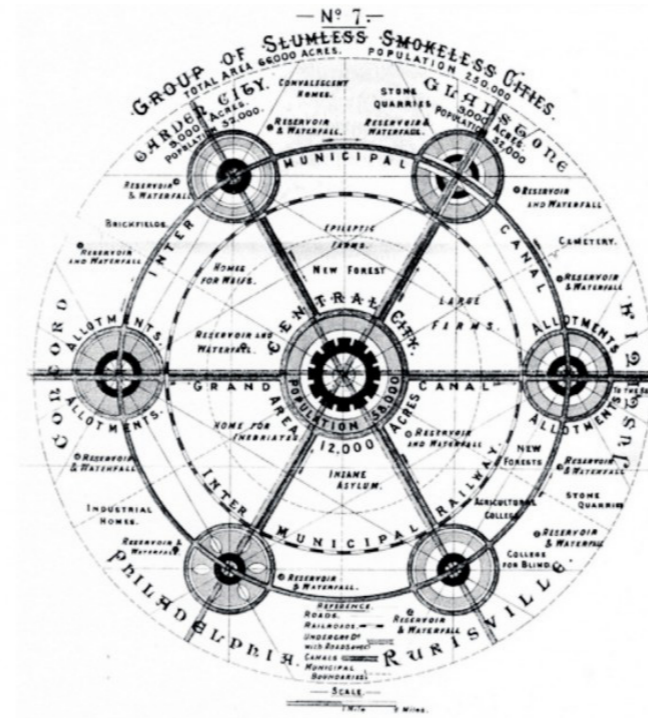

1. Urban planning: Ebenezer Howard - Garden Cities of Tomorrow
2. 'Model Houses' replacing the unhygienic dwellings and environments
3. Prevent home-based work through tenancy agreements
4. Factories required employees to be at one location to increase the control they had over their employees



information era



COVID-19
Pandemic



Growing
home-based
workforce

The workhome was the norm in many shapes and forms all over the world, until the industrial revolution



Separation of live/work



Future of home-based work?

MEDIEVAL

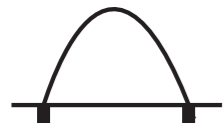

Longhouse

MEDIEVAL

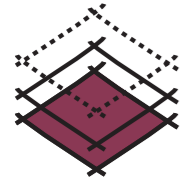

Townhouse

MEDIEVAL



Shop - Hallway - Shop
Merchant's house

MEDIEVAL



Manor house

19TH CENTURY

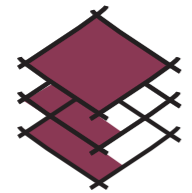

Top-shops

19TH CENTURY

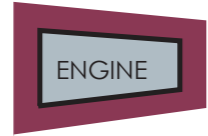

Cottage factory

19TH CENTURY

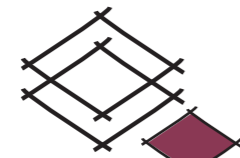

Knitters' cottages

19TH CENTURY

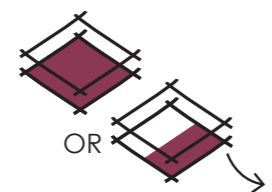

Shop-houses
OR
Small shops



1. Urban planning: Ebenezer Howard - Garden Cities of Tomorrow
2. 'Model Houses' replacing the unhygienic dwellings and environments
3. Prevent home-based work through tenancy agreements
4. Factories required employees to be at one location to increase the control they had over their employees



information era



COVID-19
Pandemic



Growing
home-based
workforce



Increase of the homebased workforce

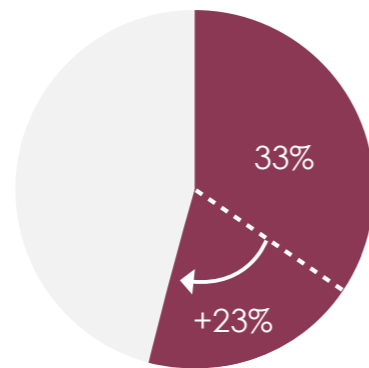

Before the pandemic about 1 in 3 workers worked occasionally at home, about 6% of them did this (almost) completely.

As a consequence of the pandemic and related restrictions the number increased up to 45-56%

Future expectation of working from home

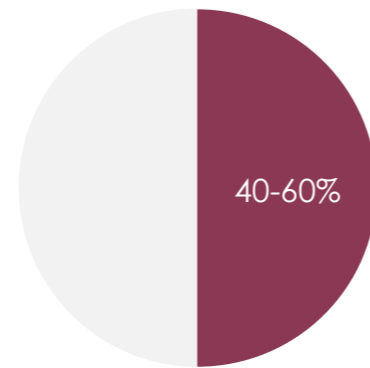

A significant proportion (roughly 40-60%) of home workers expect to work from home more often than before the pandemic.

* Predominantly 1 up to 3 days a week

Satisfaction working from home

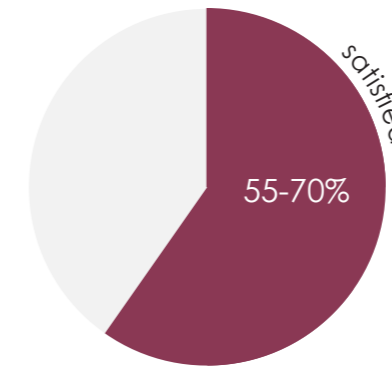

About 55-70% of home workers have positive experiences with working from home (during corona).

The majority of workers (55-70%) have positive experiences with working from home. However, the job satisfaction is lower than before the corona crisis

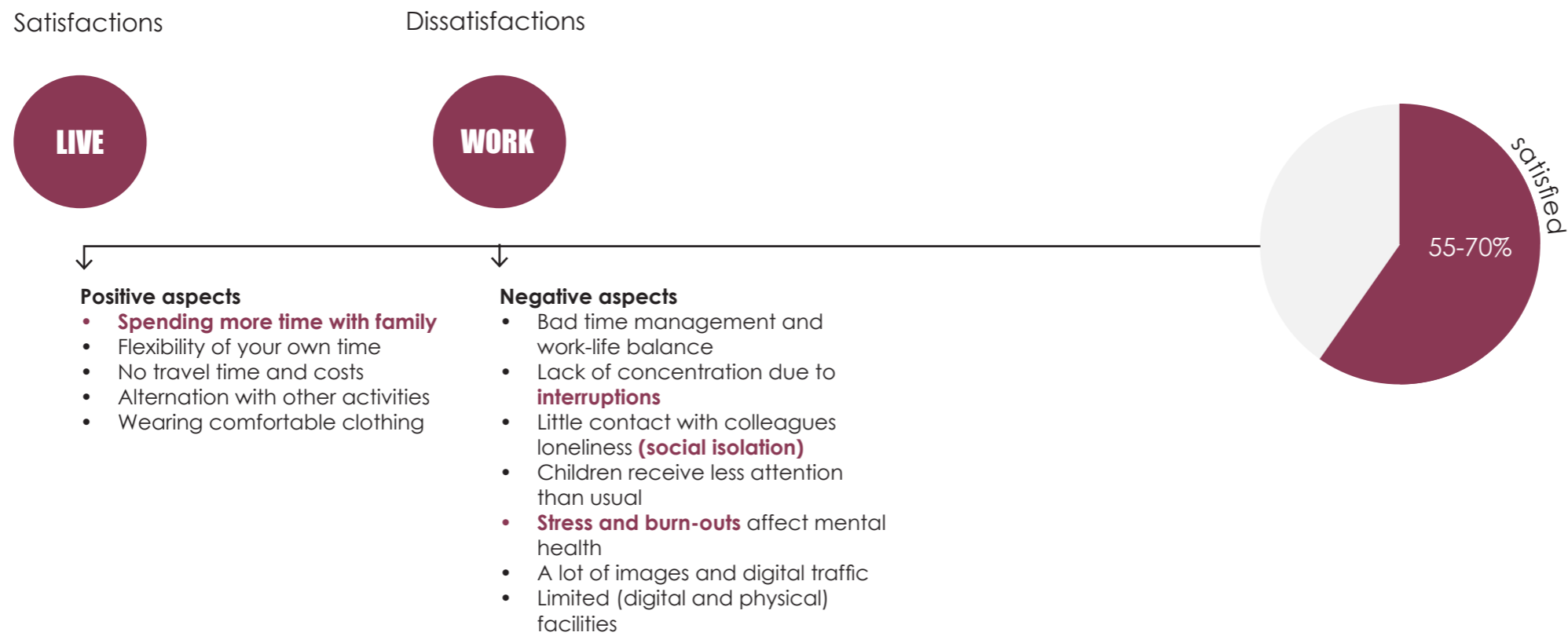

! Studies highlight that **workers with children, especially younger than the age of 12**, have more negative experience working from home than workers without children.

Target group choice: Urban families with home working parents

© Hamersma, M., de Haas, M., & Faber, R. (2020, 31 augustus). Thuiswerken en de coronacrisis - Een overzicht van studies naar de omvang, beleving en toekomstverwachting van thuiswerken in coronatijd. Kennisinstituut voor Mobiliteitsbeleid.

© NCJ. (2015). Ontwikkelingsaspecten en Omgevingsinteractie.

How can family life, child supervision and work-life take place at the same time, in the same dwelling – and how can dwelling design actively support such complex social relations?

Single parent with toddlers

Modern nuclear family

URBAN FAMILIES

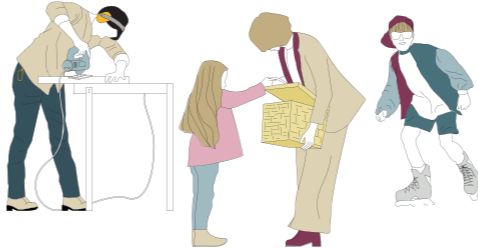
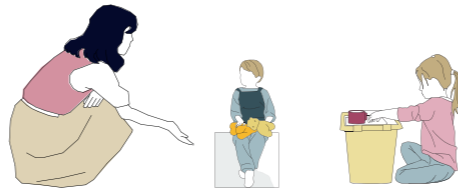

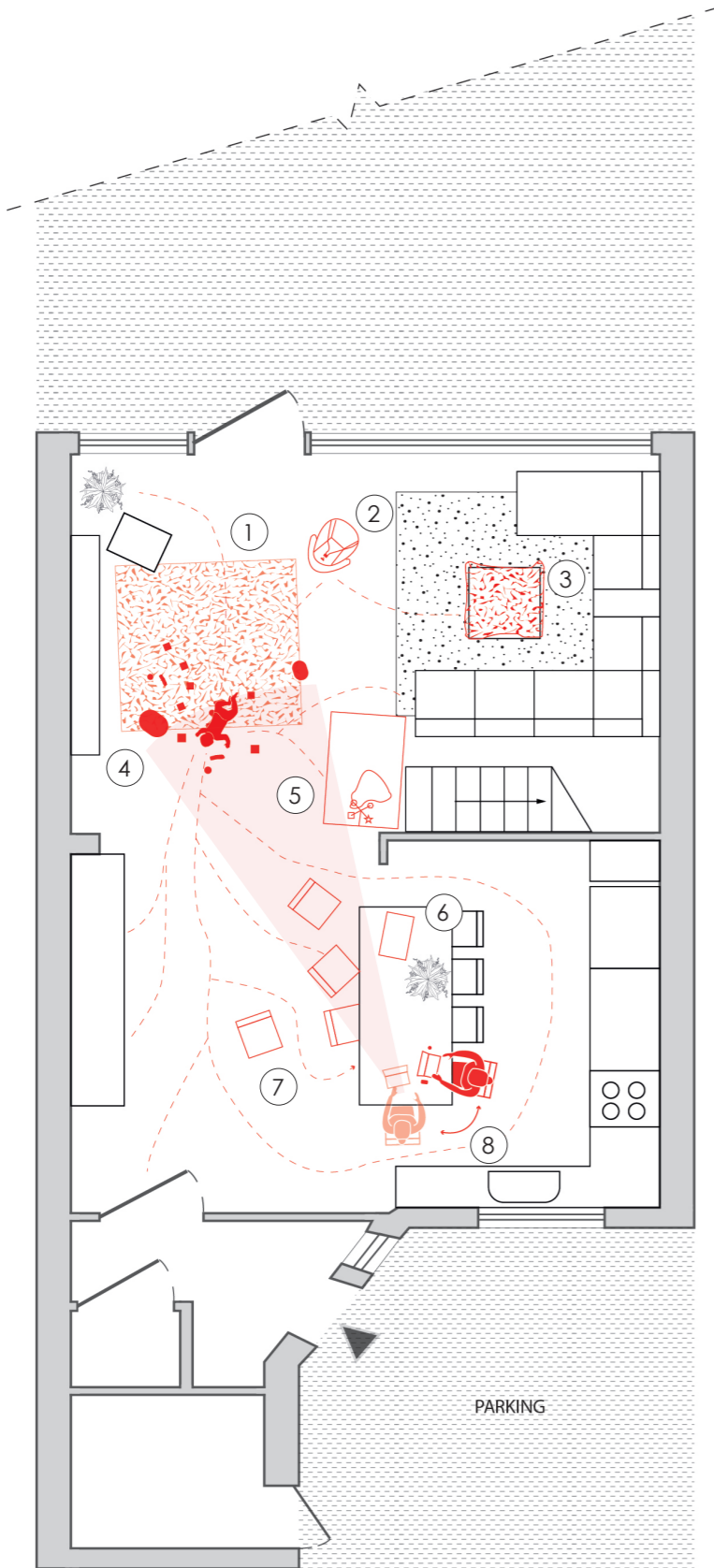

1. Rubber safety mat with a playful pattern.
2. Automatic swinging chair with a safety belt to watch television.
3. Blanket to cover sharp edges of the coffee table.
4. Toys to entertain the toddler during working hours.
5. Playpen blocking stairs to prevent the toddler from going up.
6. Changing pad within reach to minimize care time.
7. The walking route of the child and the disorganization of space.
8. Mother switches her work position for supervision.



Family van Modem- SCHOOL AGED CHILDREN
(Modern nuclear family)

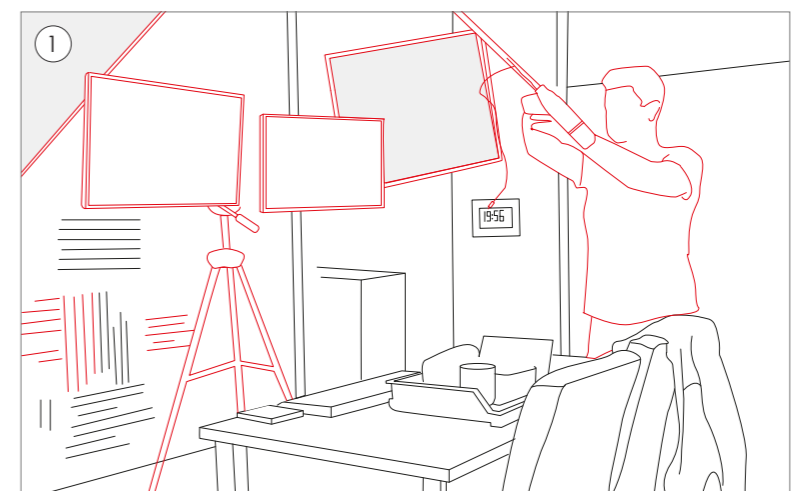
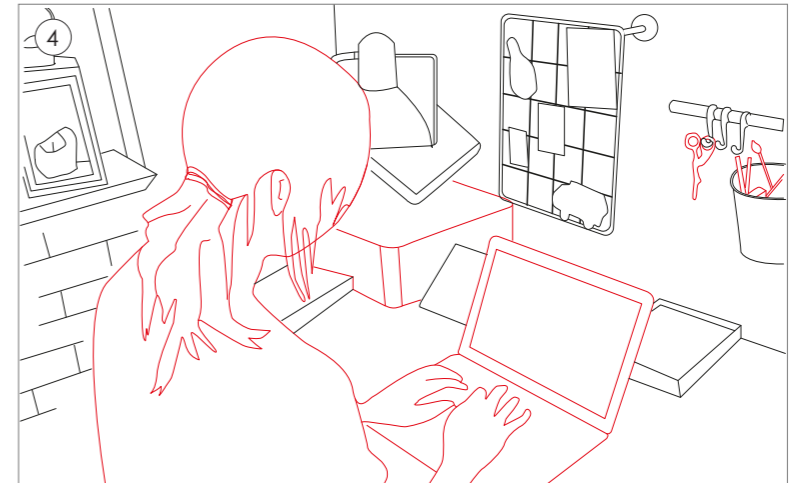
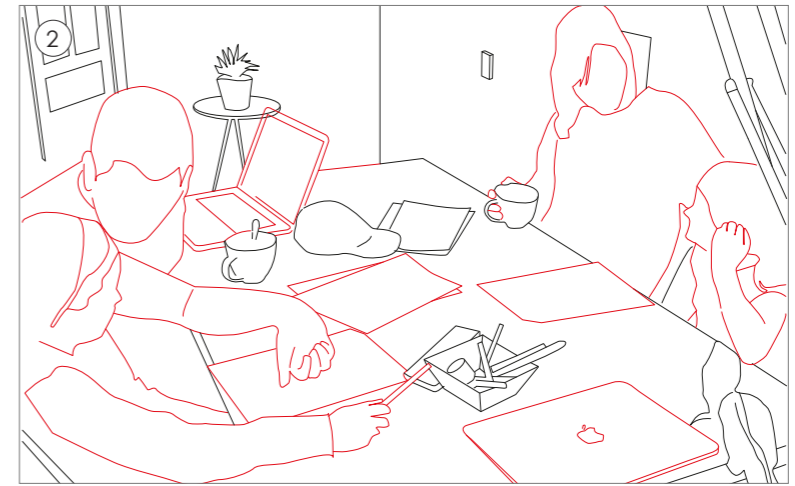
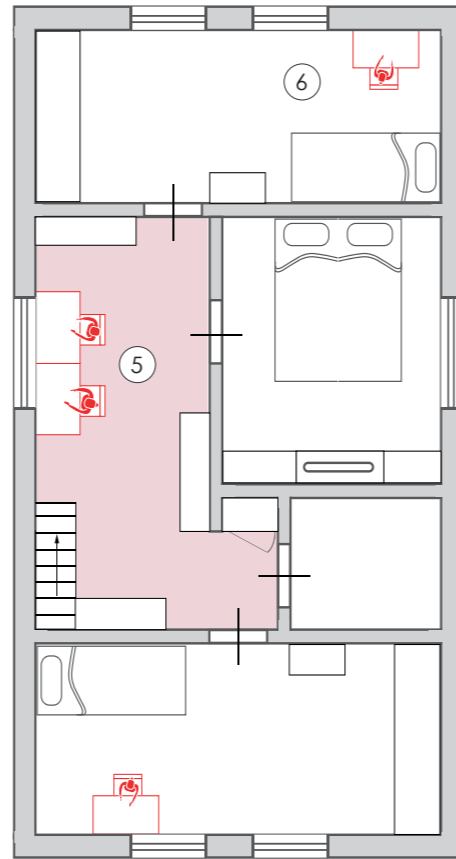
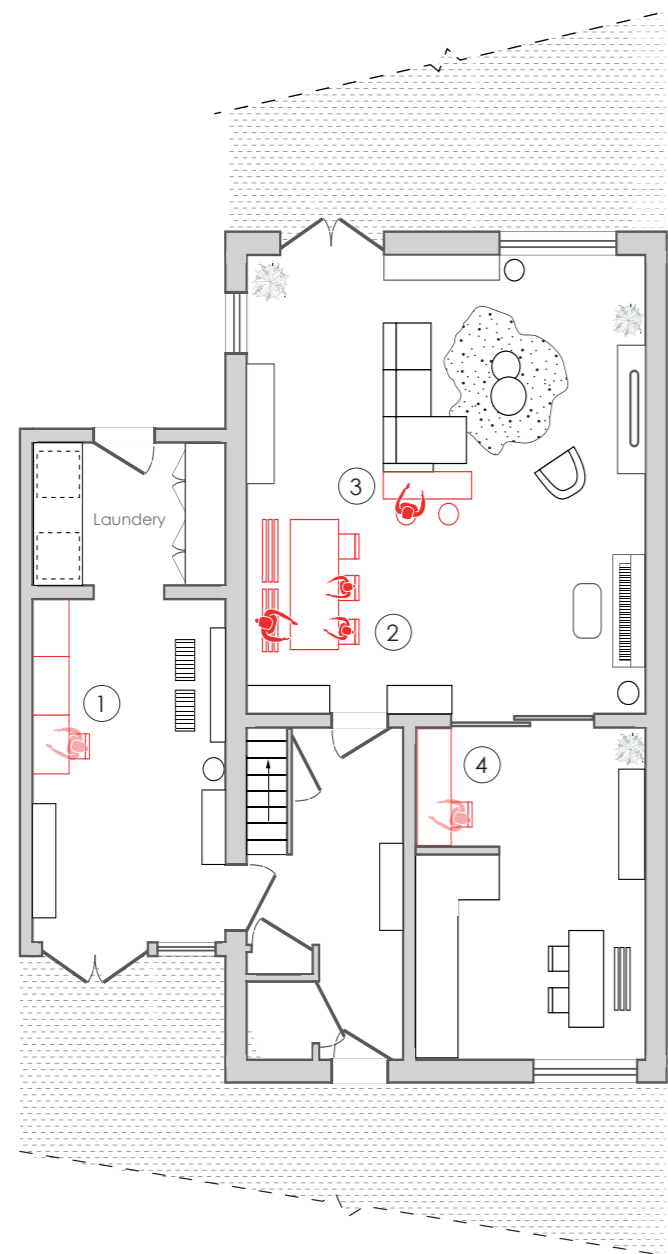

1. Craft and paint workshop, occasionally transformed into a live-stream studio.
2. The collective table in the living room is dedicated to waged work and educational activities.
3. A small separate desk allows one parent to work whilst being part of family life.
4. Small craft and edit space for in-between hours.
5. The workspaces of both parents with fixed computers are organized in the hallway on the second floor.
6. Both children have an individual desk.

Family van Modem - SCHOOL AGED CHILDREN
 (Modern nuclear family)

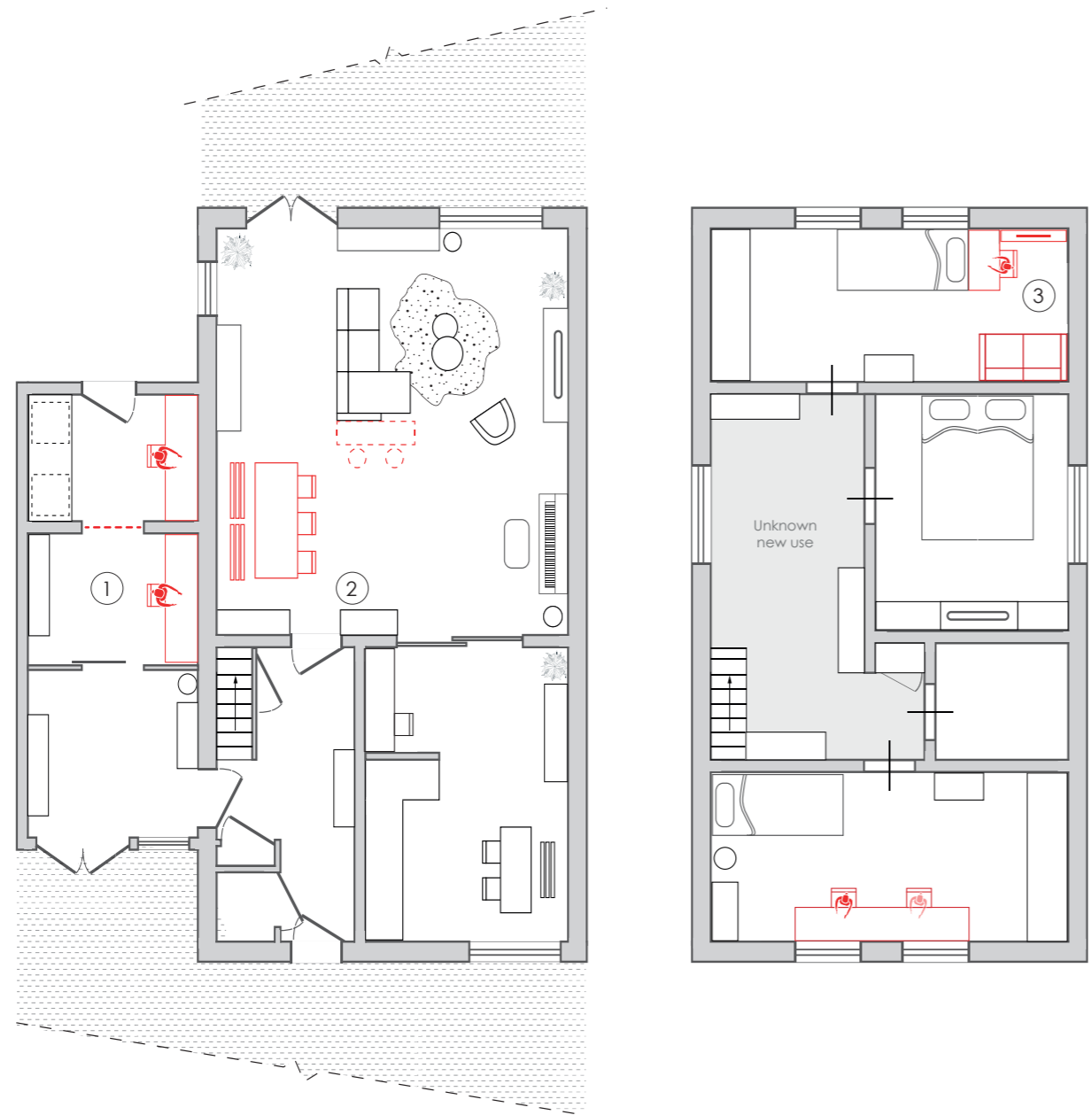

1. The workspace in the hall on the second floor has been moved to the extension. The workplace of both parents has a clear boundary and is separated from family life (live-nearby). The sliding wall allows the parents to work collectively, but also individually without interrupting each other. The new use of the hallway on the second floor is unknown.
2. The collective workspace remains.
3. The children's bedrooms are upgraded as the needs change as they grow older and the private space will be used more intensively.

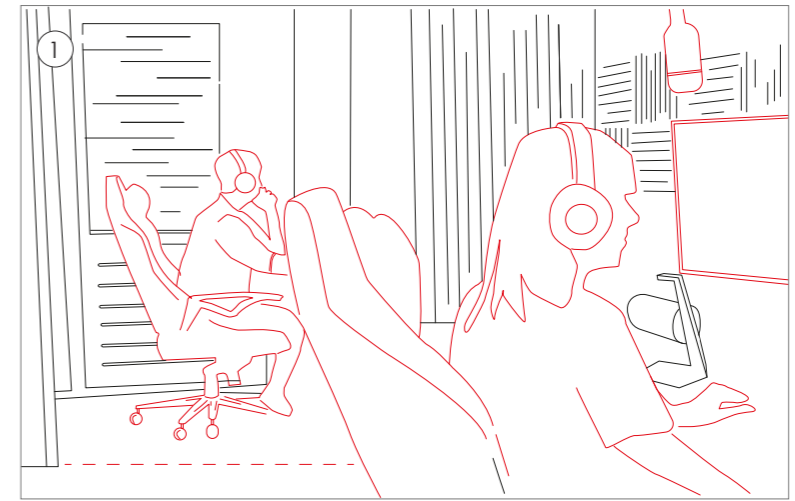
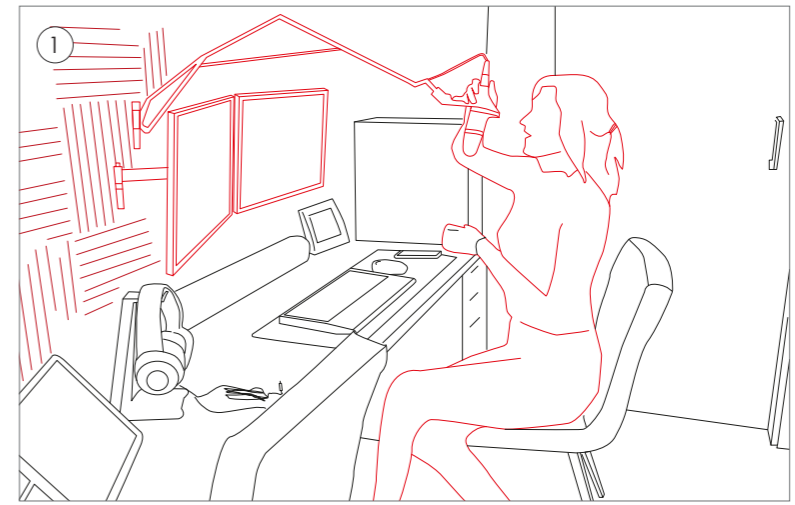

Dependent children

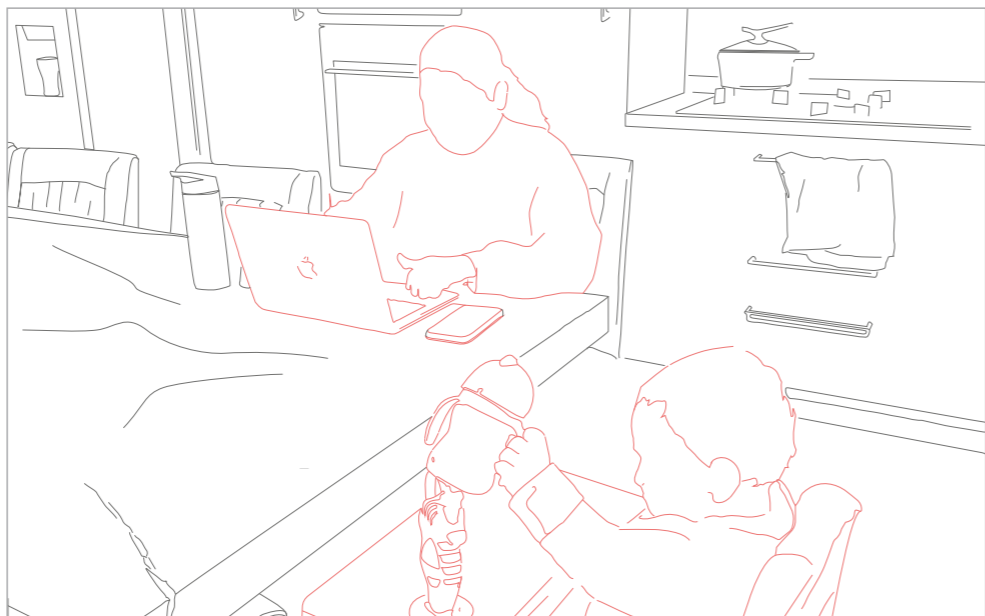

Independent children

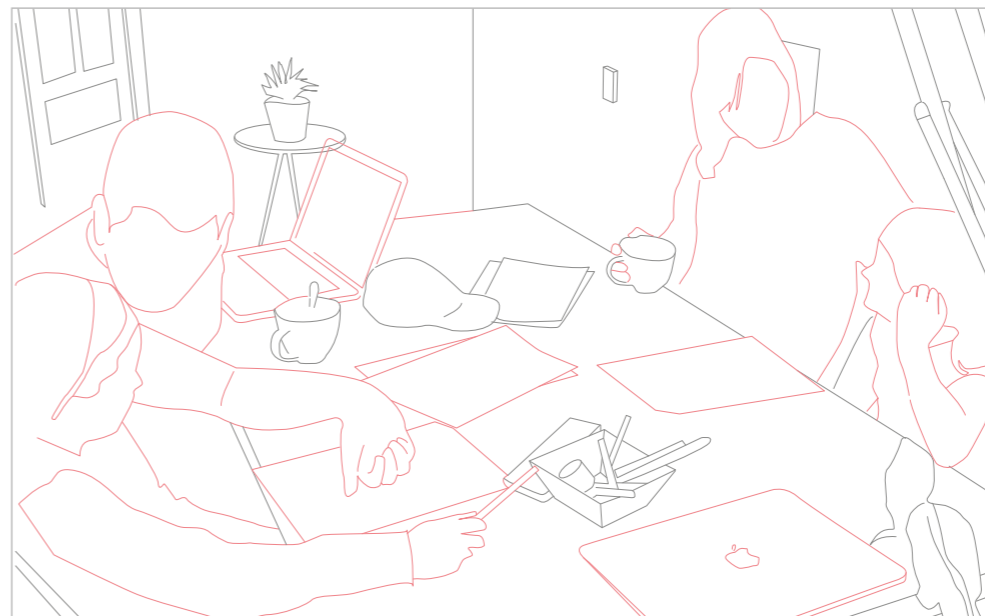

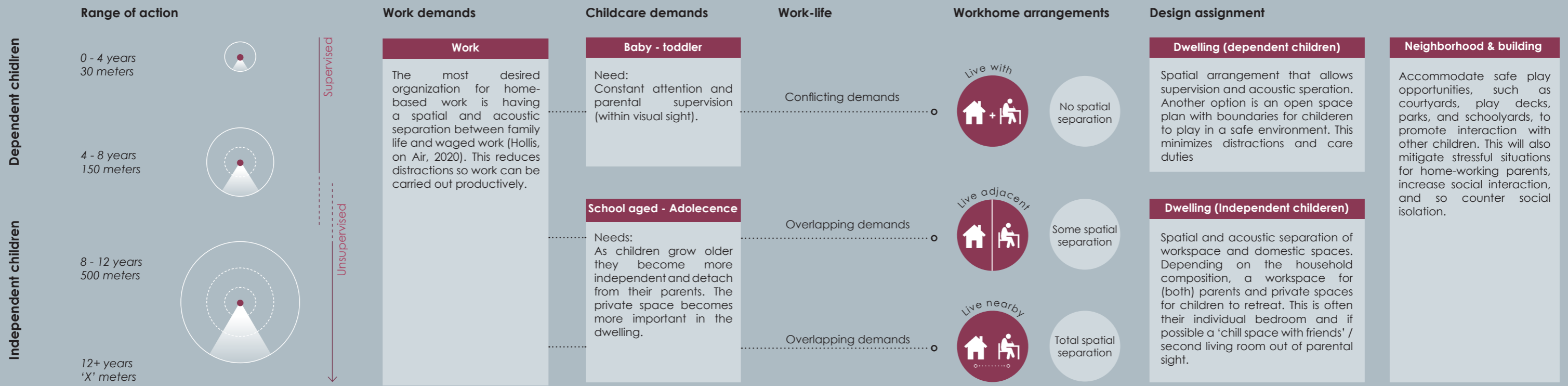

Design principles for home working parents with children

Neighborhood



Safety



Outdoor space



No/Low Traffic



Play garden



Day-care



Other families



Café & Supermarket



Schools

Building

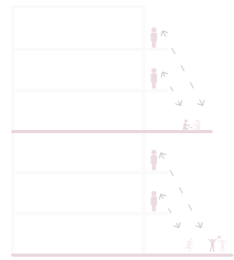

Max. 03 level height difference for supervision



Clustering families and sharing care tasks



Dual-use of space

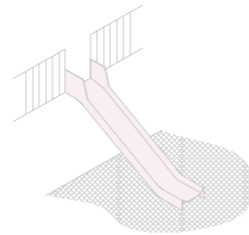

Connect levels playfully



Space for play instead of parking



Make work visible

Dwelling



Adaptability of spaces

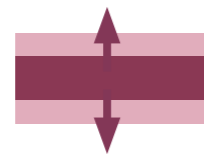

Oversized hallway for work, play and supervision

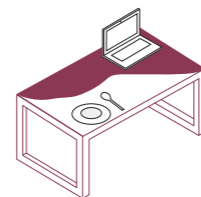

Dual-use



Supervision vs Boundaries



'Professional' background

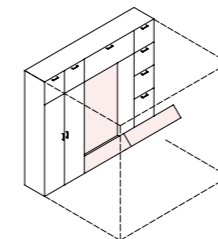

Transformable furniture



Design for a specific target group

DESIGN

Site

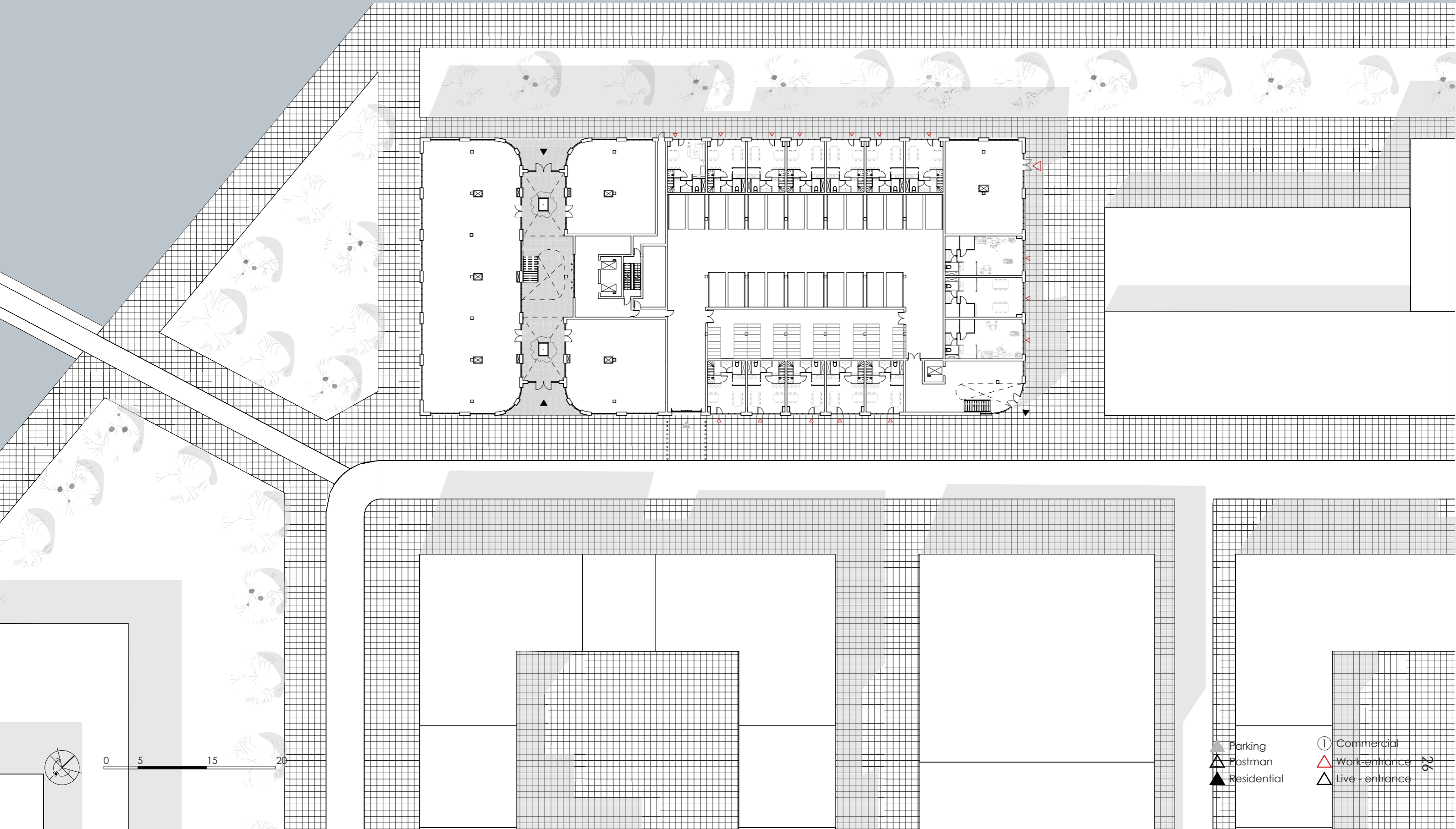

- ▲ Parking
- ▲ Postman
- ▲ Residential
- ① Commercial
- ▲ Work-entrance
- ▲ Live-entrance

0 5 15 20





- Dwelling
- Functional
- Commercial
- Work/Play
- Circulation

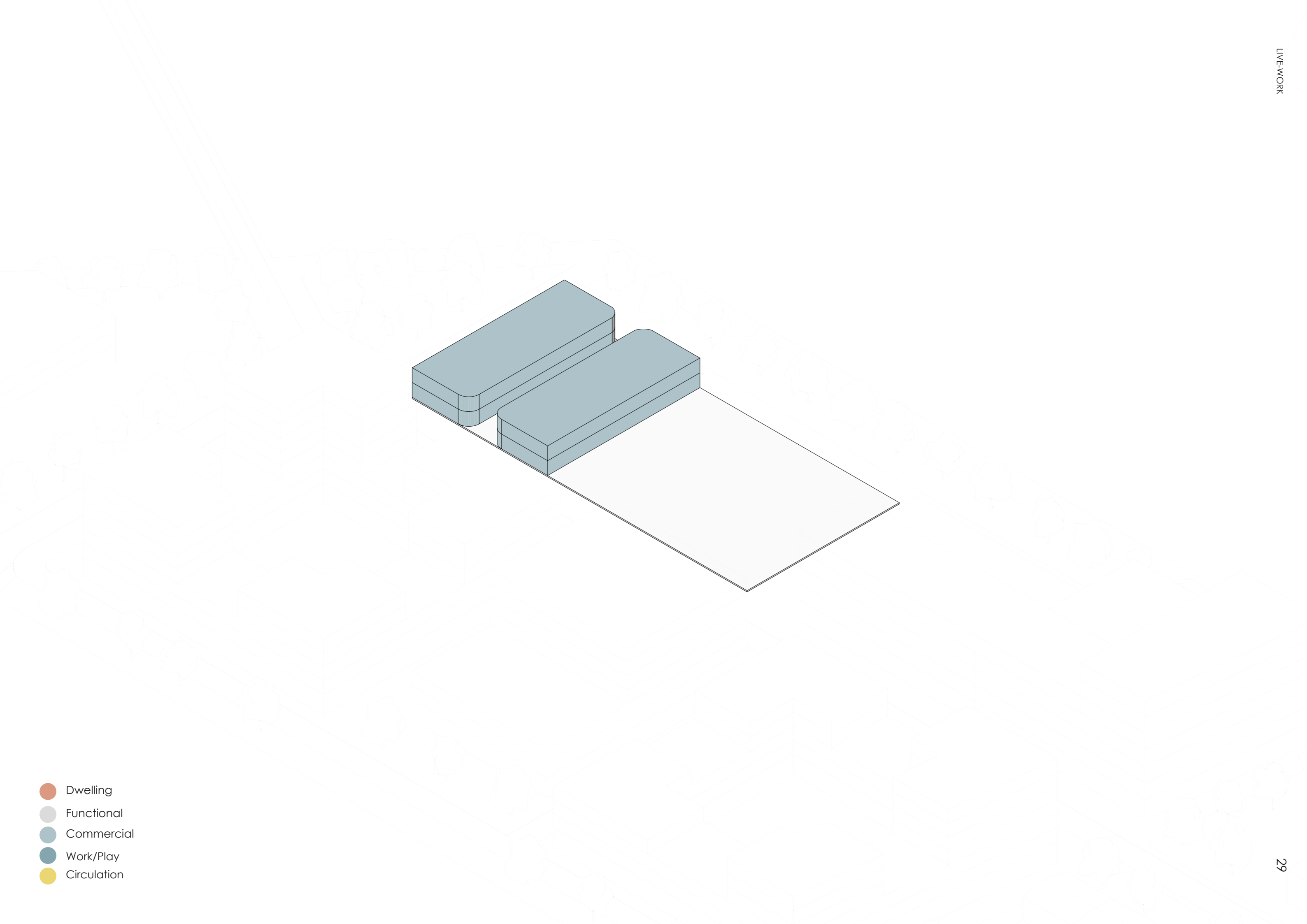

- Dwelling
- Functional
- Commercial
- Work/Play
- Circulation

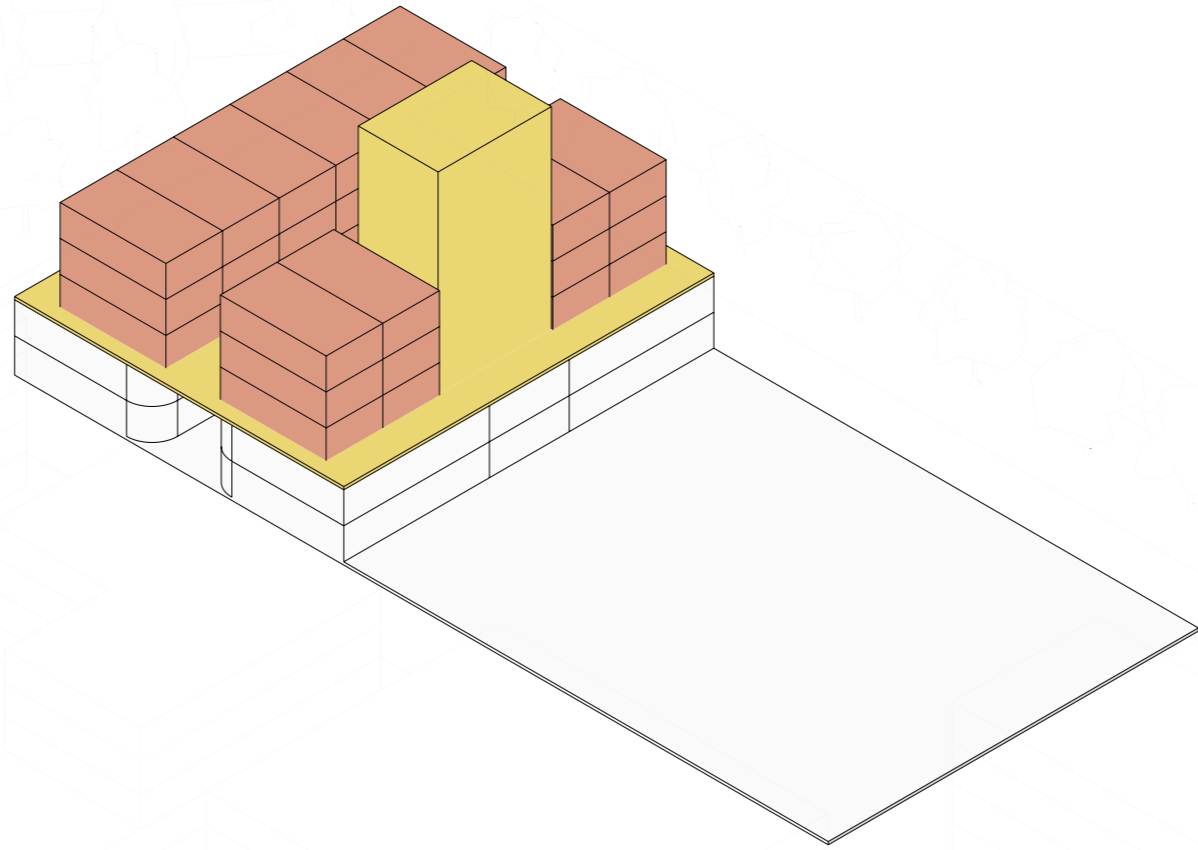

- Dwelling
- Functional
- Commercial
- Work/Play
- Circulation

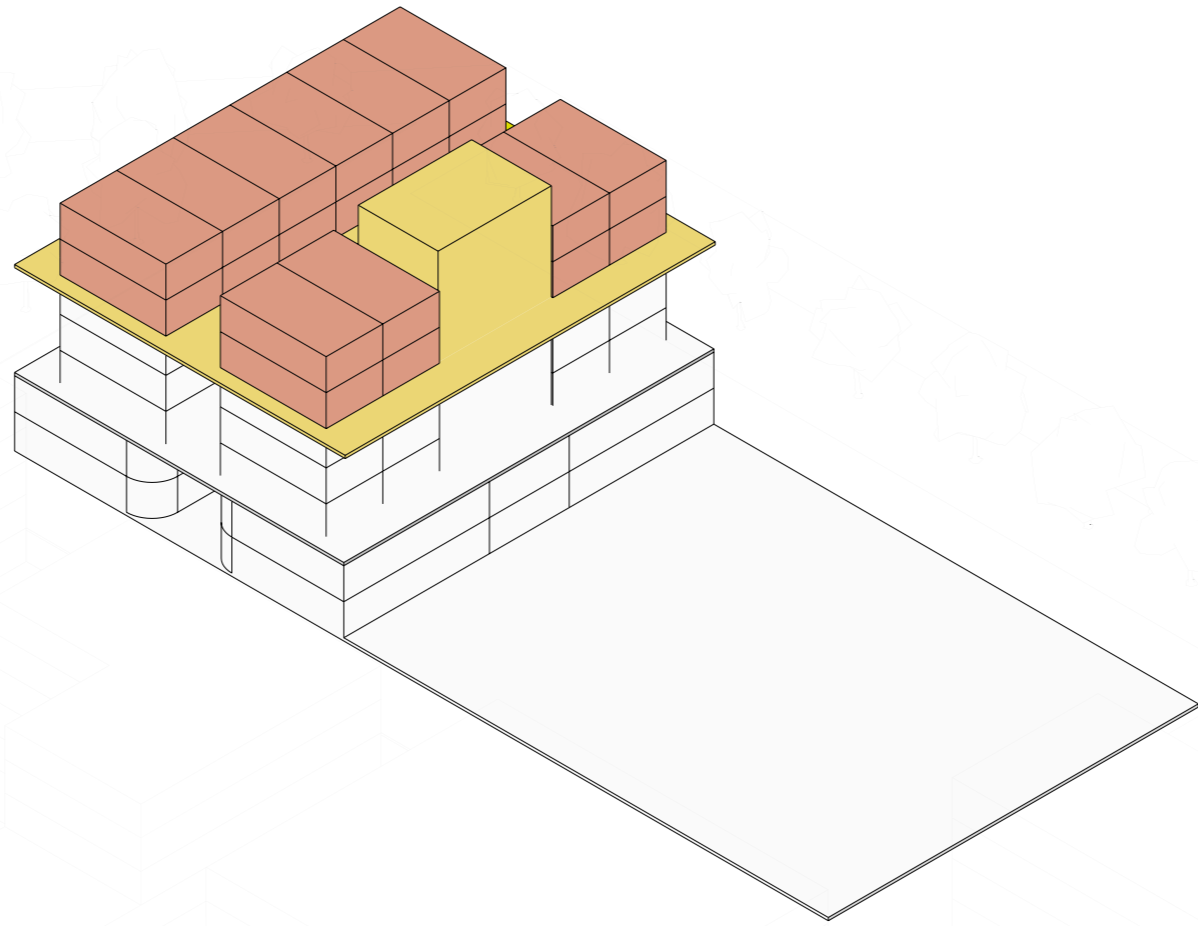

- Dwelling
- Functional
- Commercial
- Work/Play
- Circulation

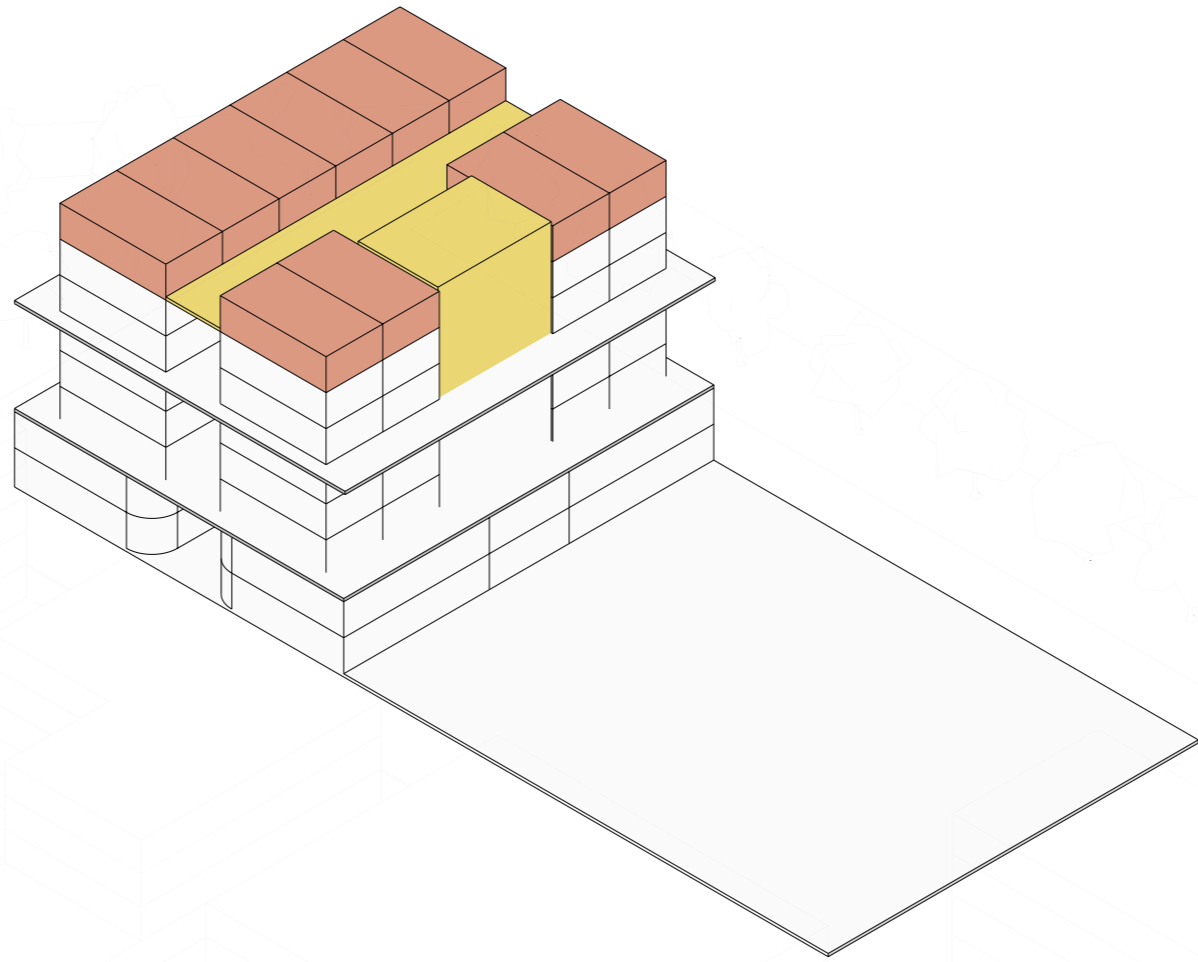

- Dwelling
- Functional
- Commercial
- Work/Play
- Circulation

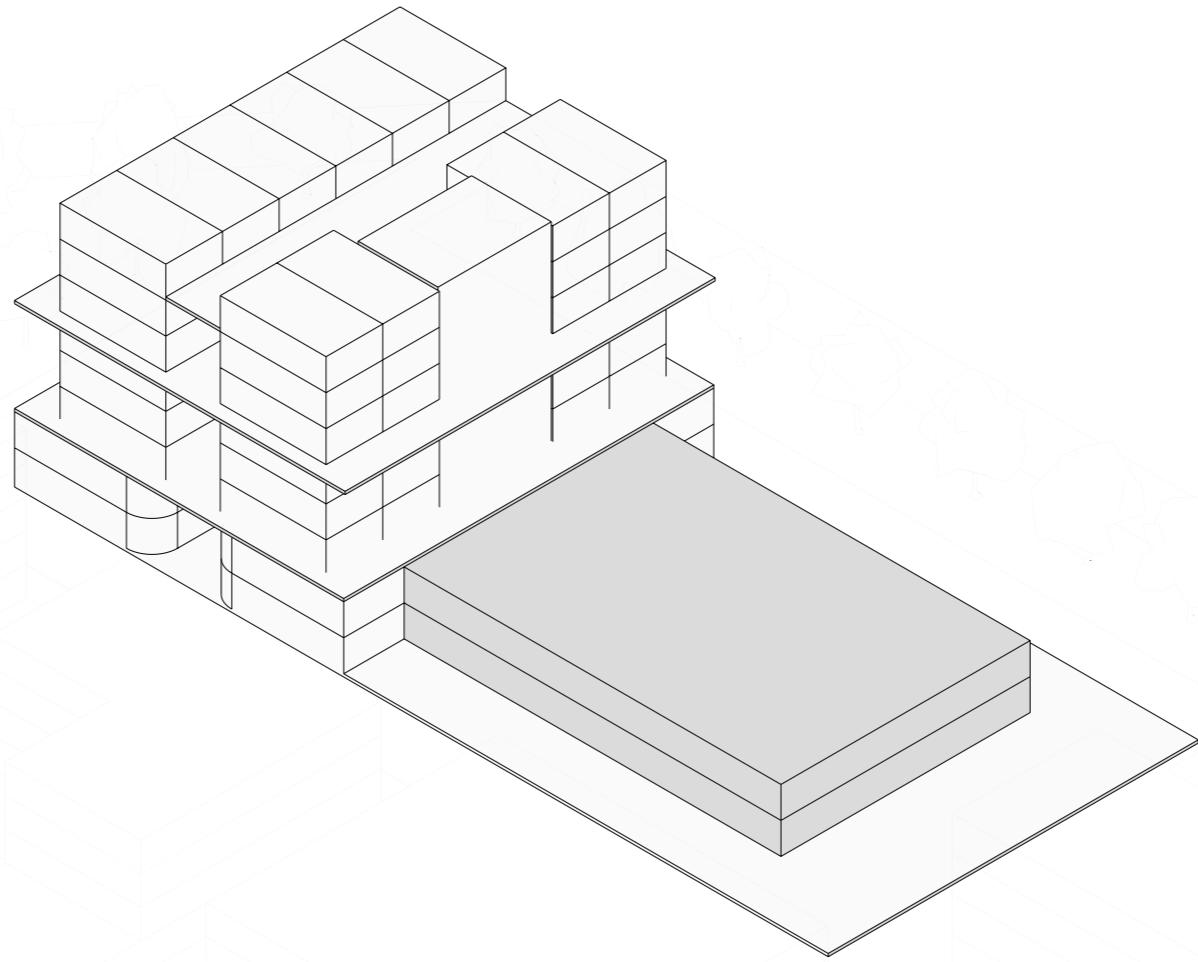

- Dwelling
- Functional
- Commercial
- Work/Play
- Circulation

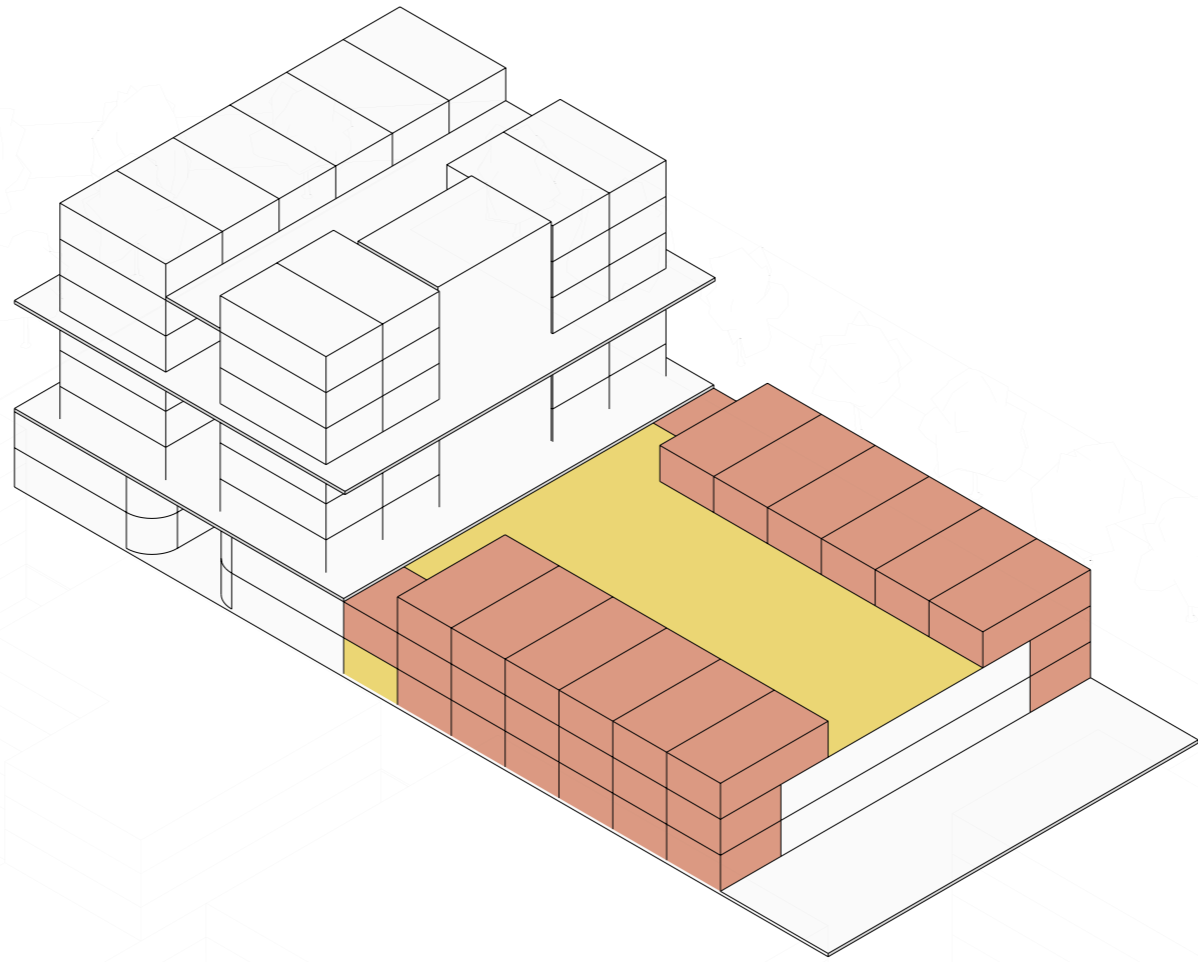

- Dwelling
- Functional
- Commercial
- Work/Play
- Circulation

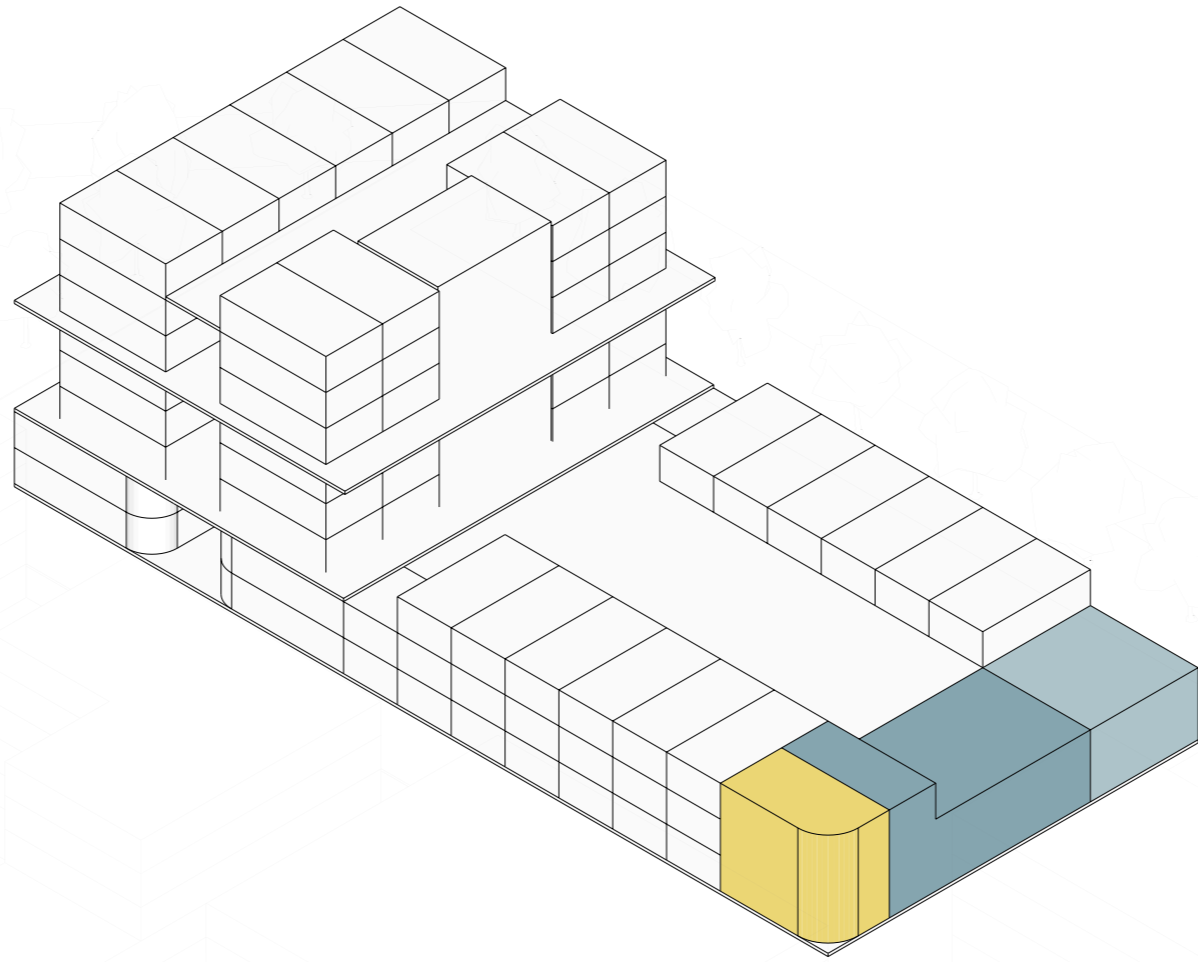

- Dwelling
- Functional
- Commercial
- Work/Play
- Circulation

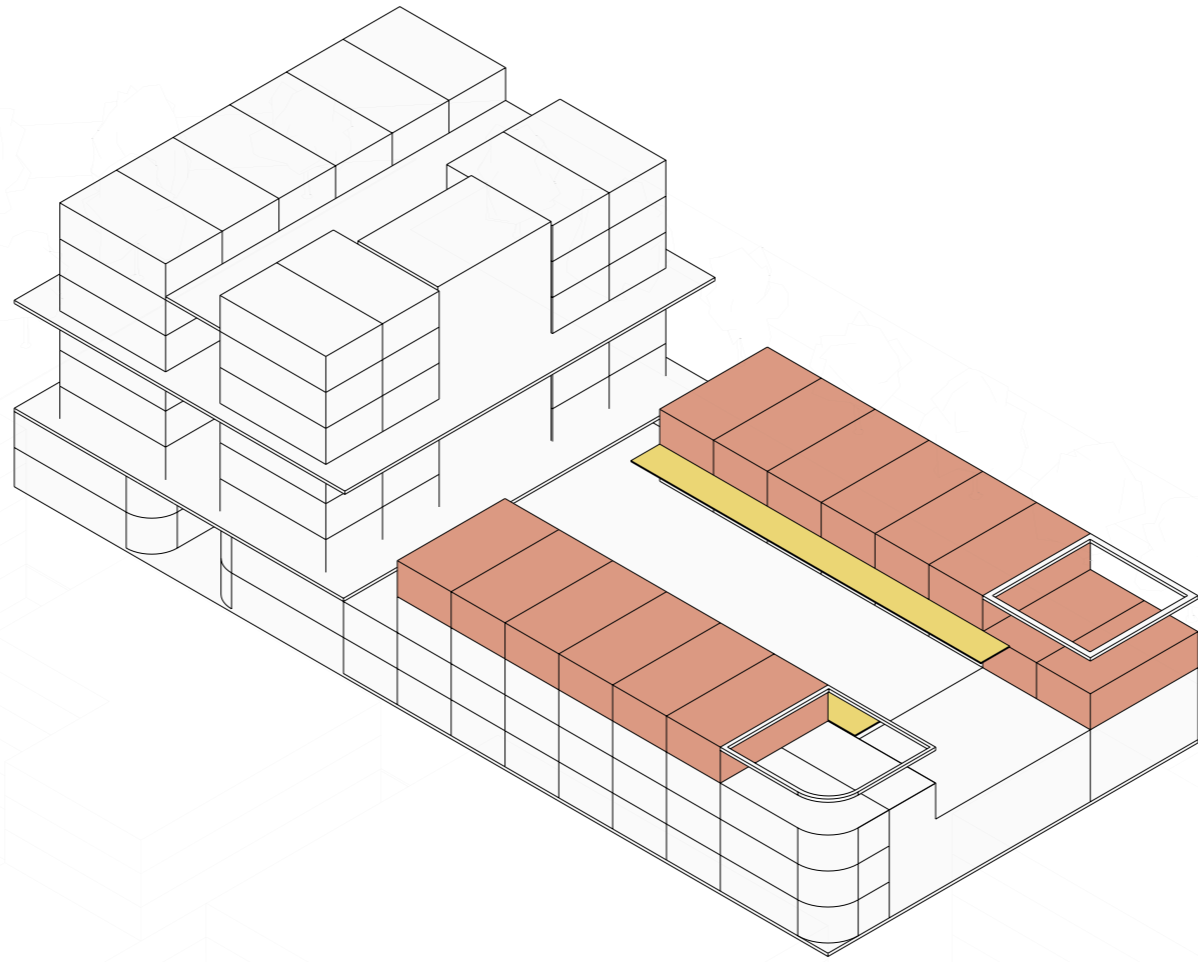

- Dwelling
- Functional
- Commercial
- Work/Play
- Circulation

Building concept based on the context

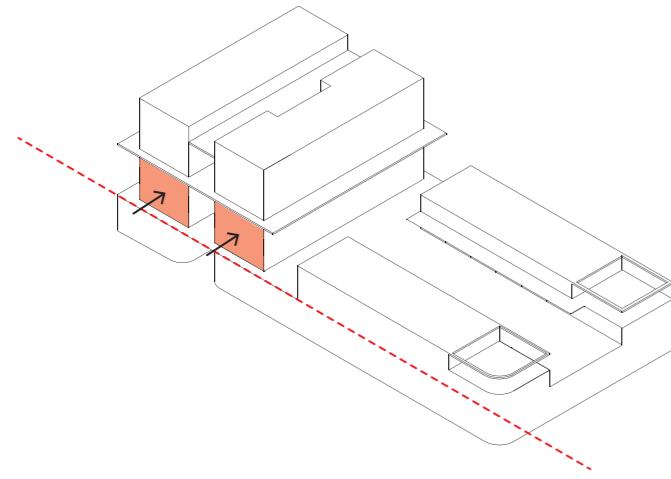

Height of ware houses and setback 'Rotterdamse Laag'

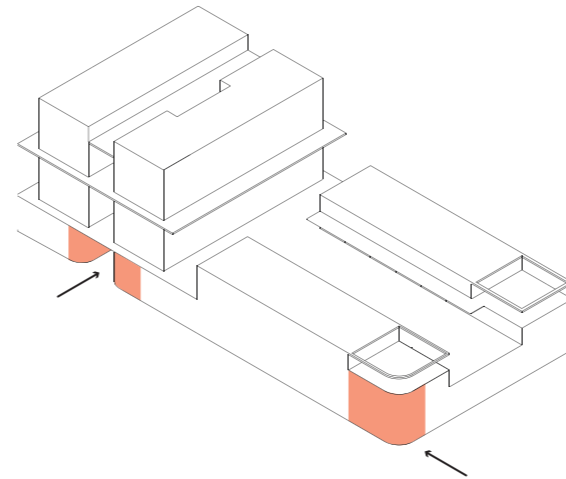

Curving the building mass to highlight the entrances

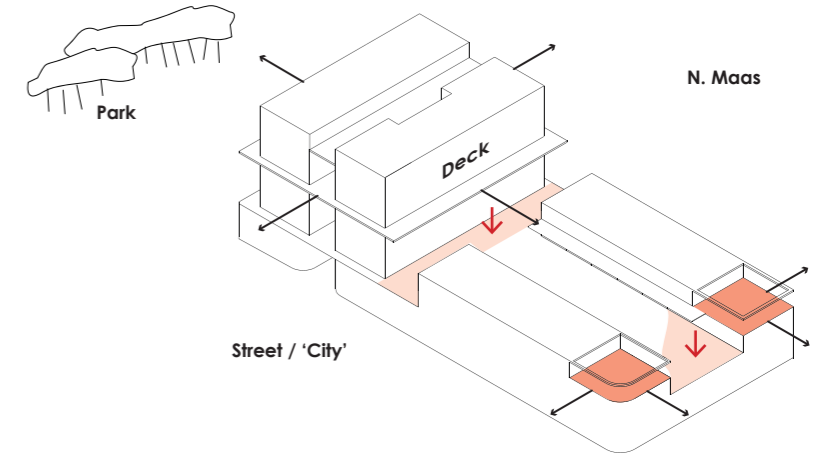

View and connections
● Lower volume to give deck 'air'

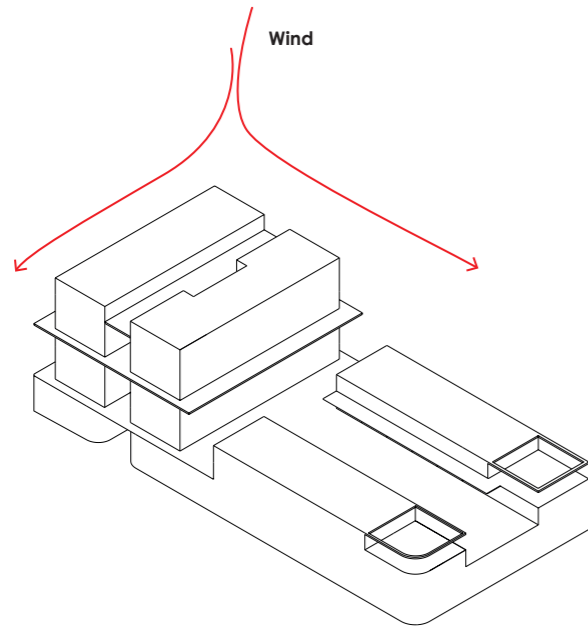

Protect deck from wind

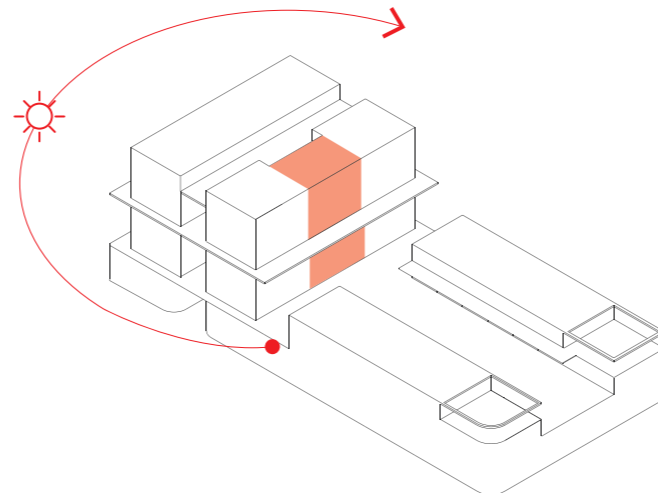

Circulation oriented toward the north for sun path and visibility of play deck



Streets in the building

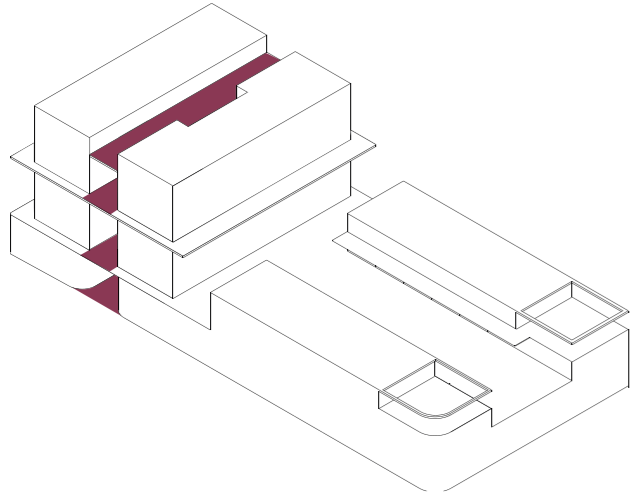

The street



Streets in the building

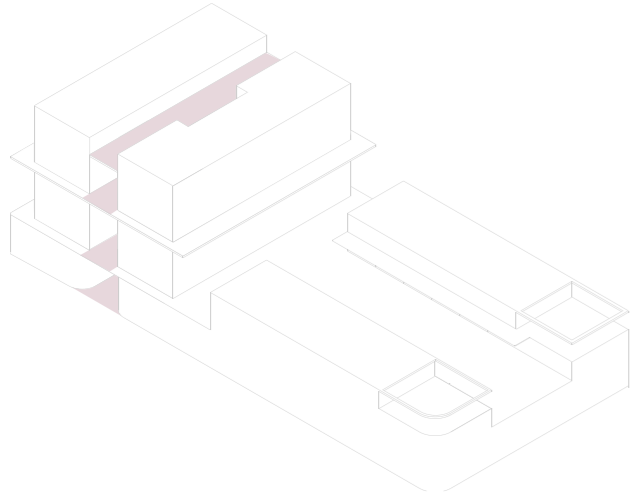

The street



The sidewalk



Streets in the building

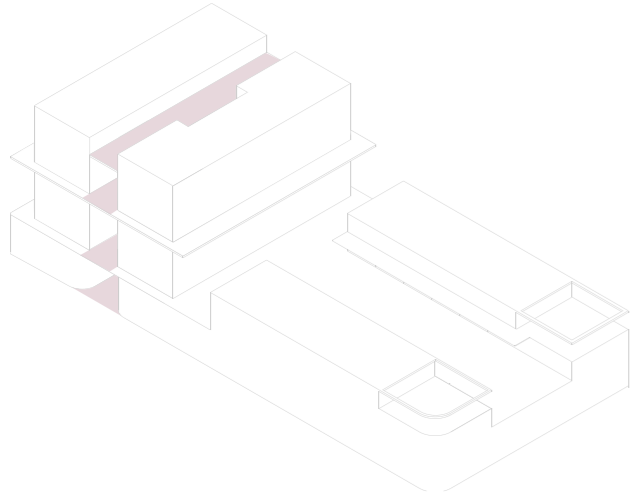

The street

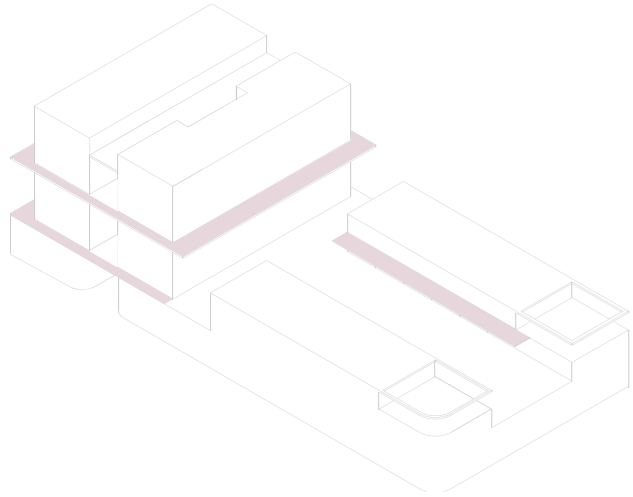

The sidewalk

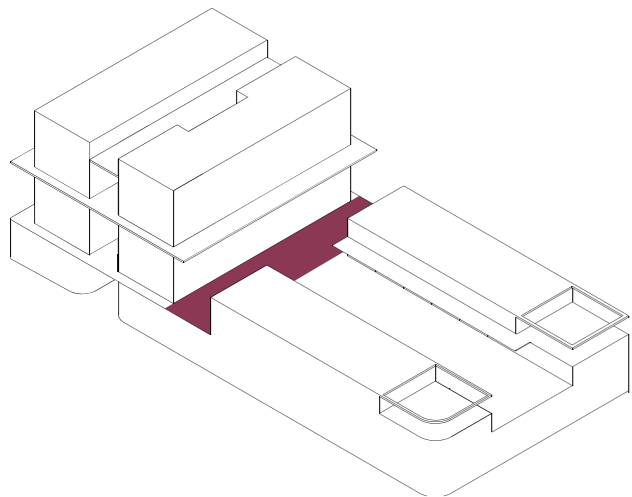

The Square



Streets in the building

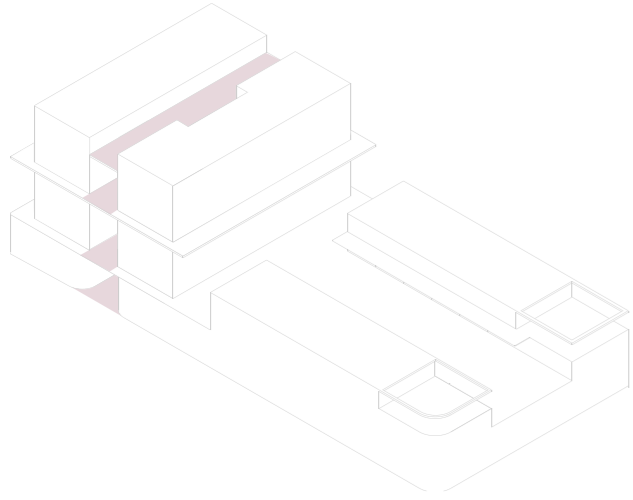

The street

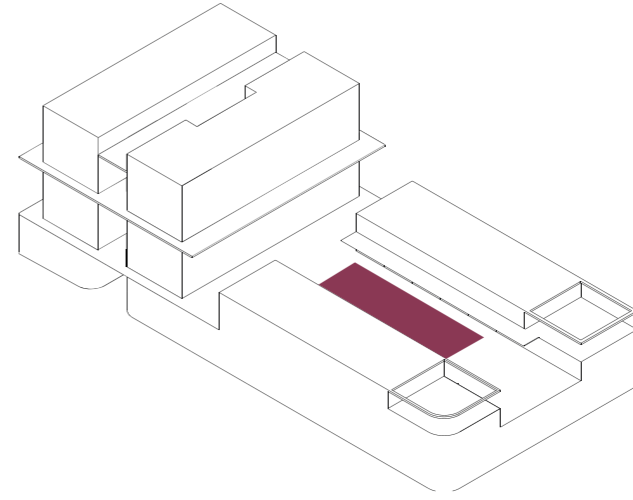

The field

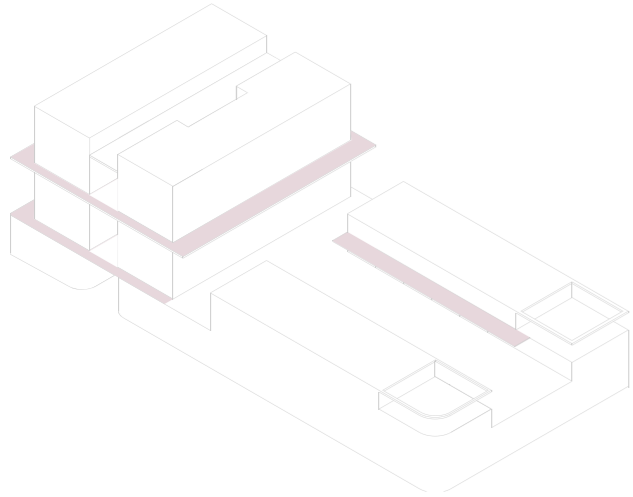

The sidewalk

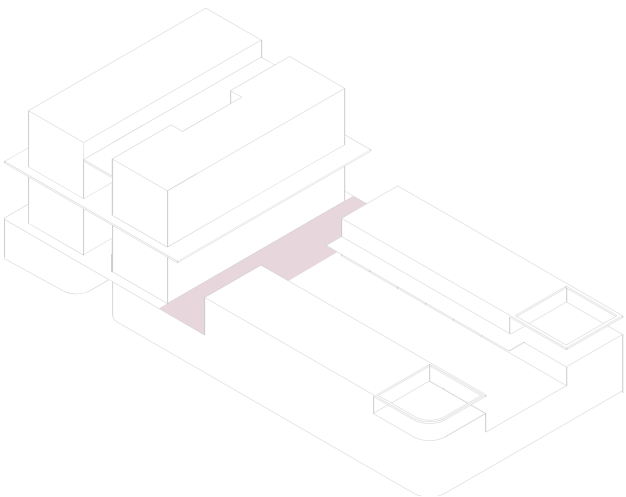

The Square



Streets in the building

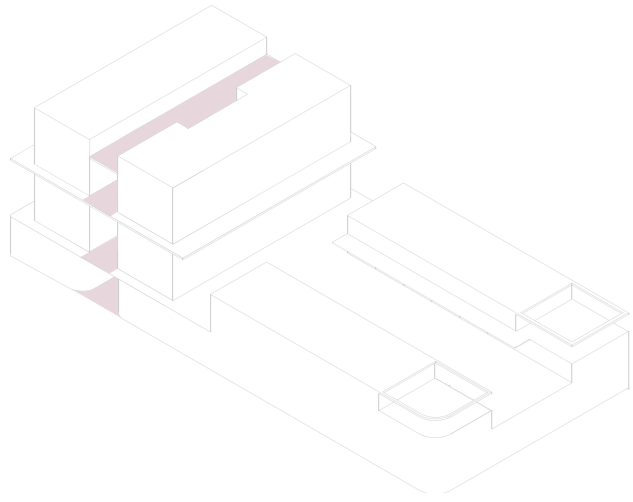

The street

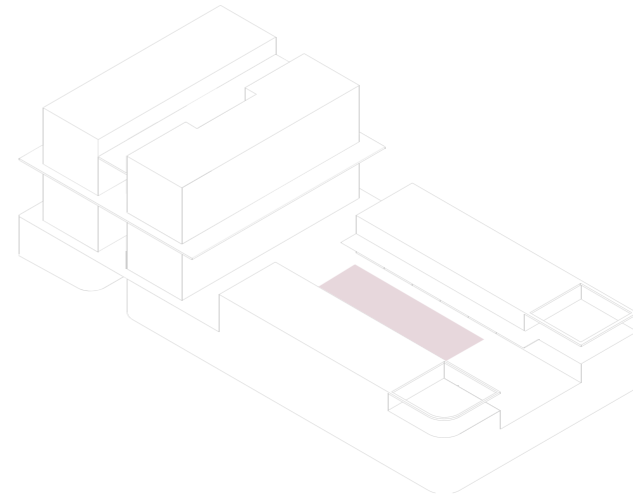

The field

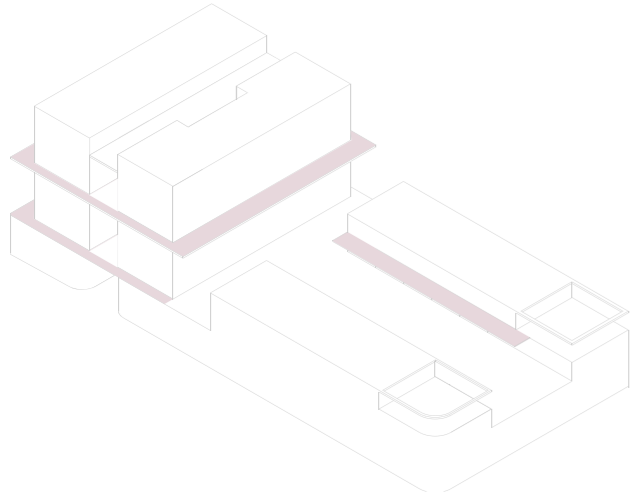

The sidewalk

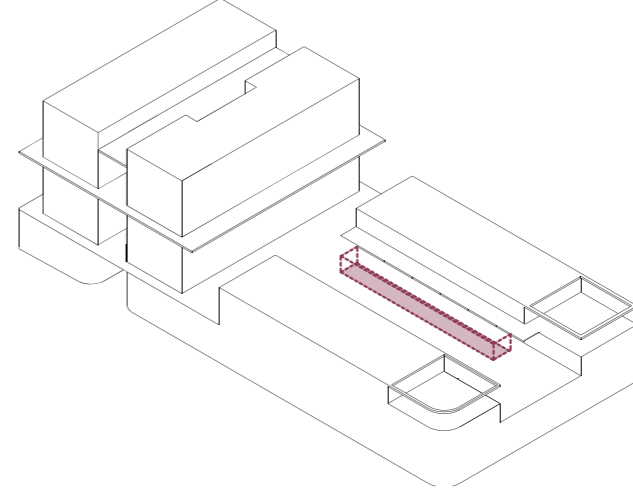

The alley

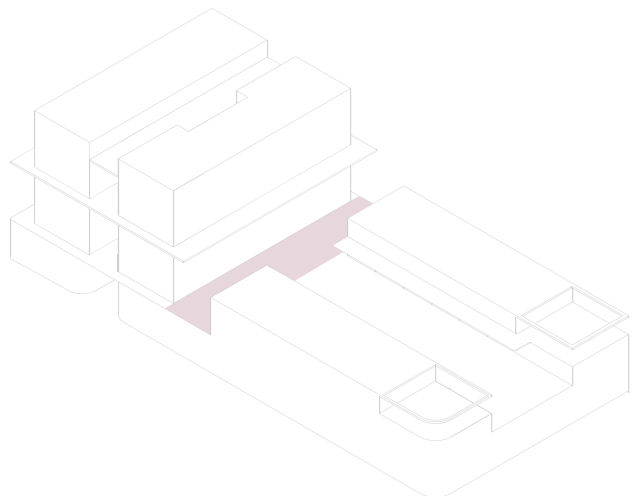

The Square



Level 01 - Ground floor

6500 8250 6500 8250 6500 5700 5700 5700 5700 5700 5700 5700 5700 5700

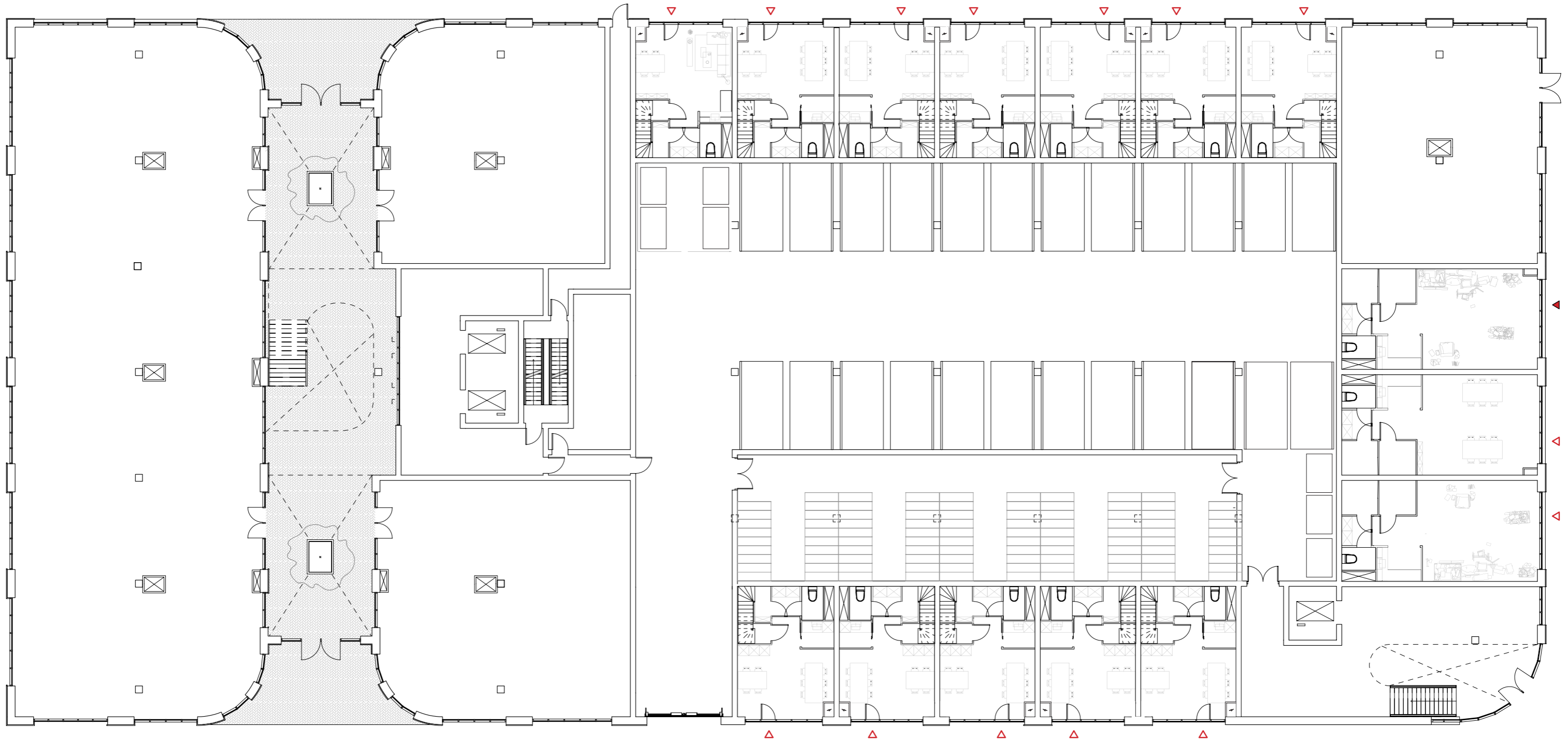

0 2.5 7.5 12.5m

△ Work-entrance
▲ Live - entrance

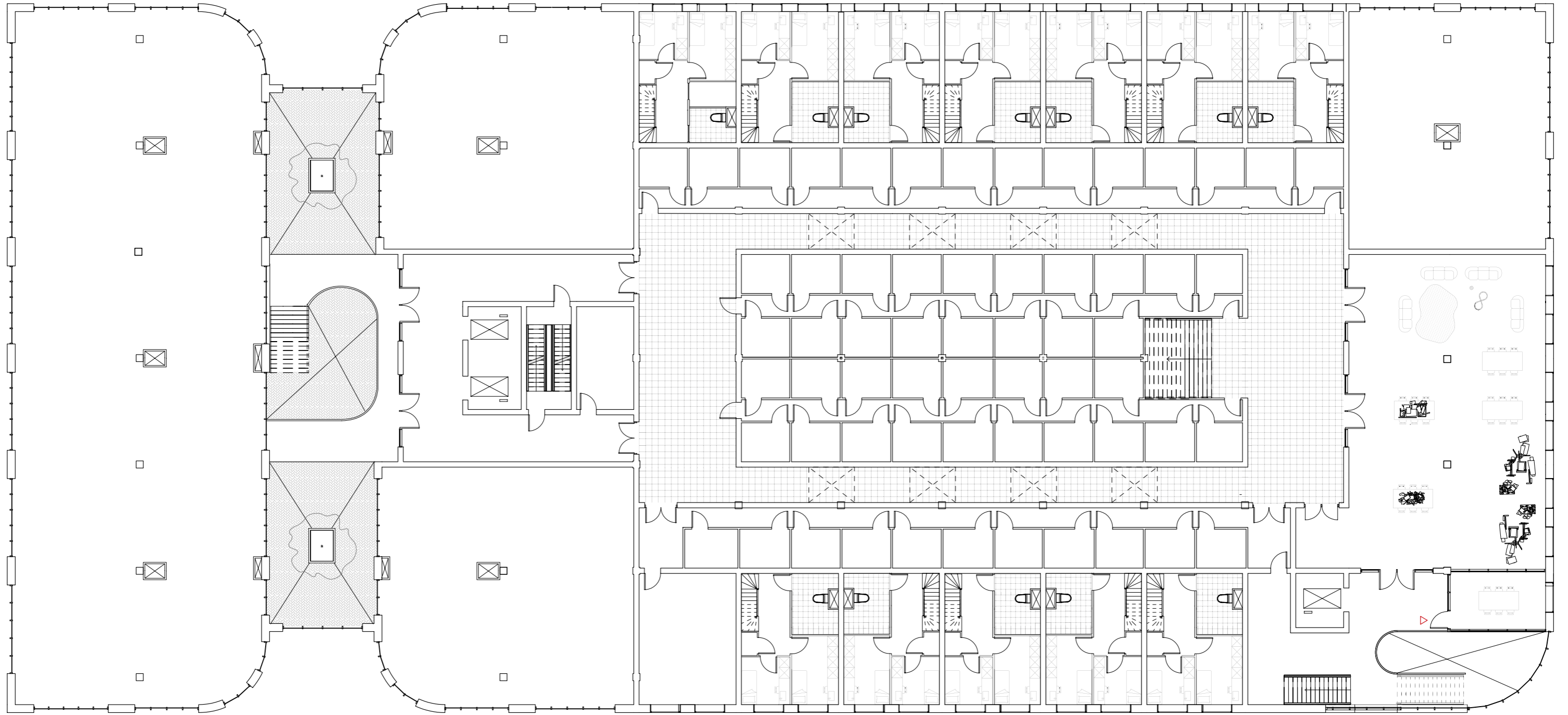

0 2.5 7.5 12.5m

△ Work-entrance





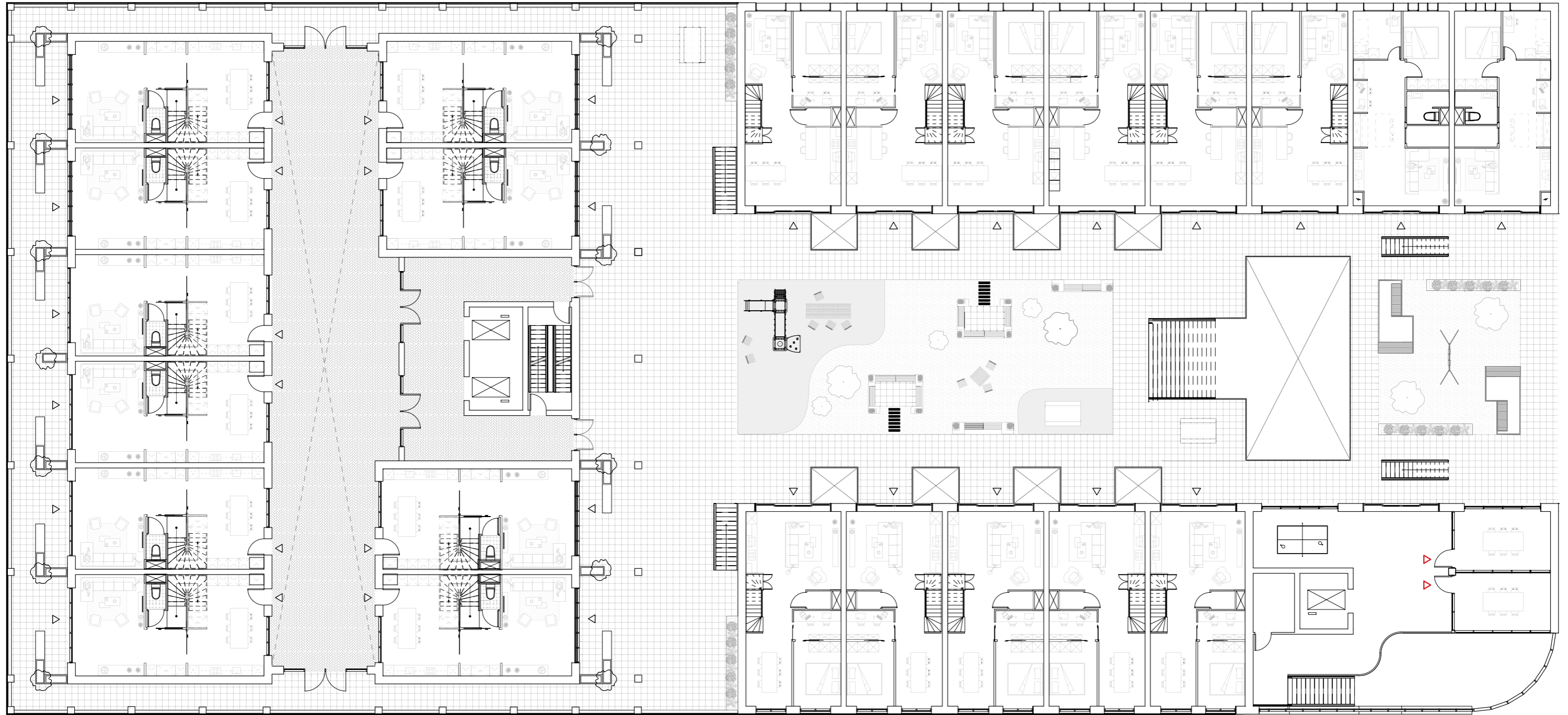

0 2.5 7.5 12.5m

△ Work-entrance
△ Live - entrance



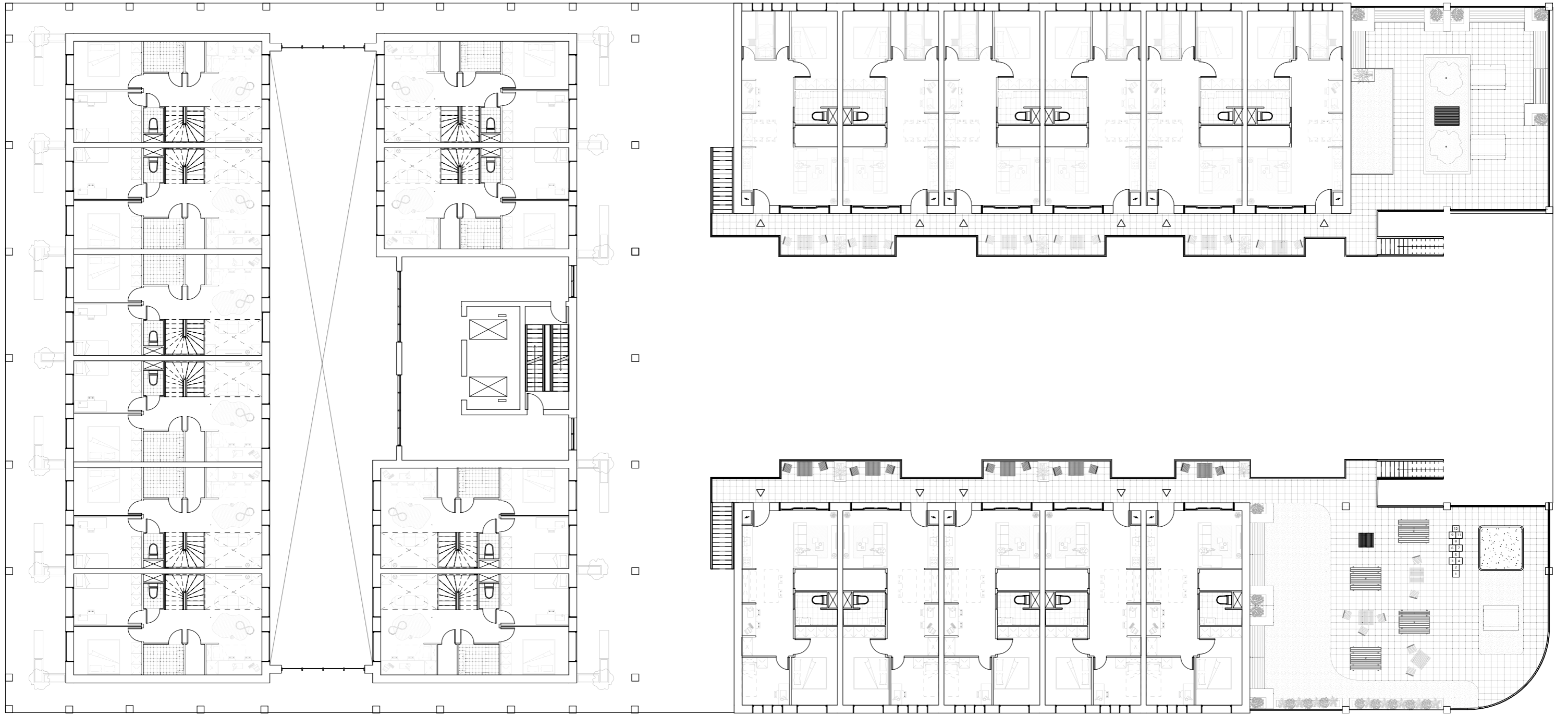

0 2.5 7.5 12.5m

△ Live - entrance



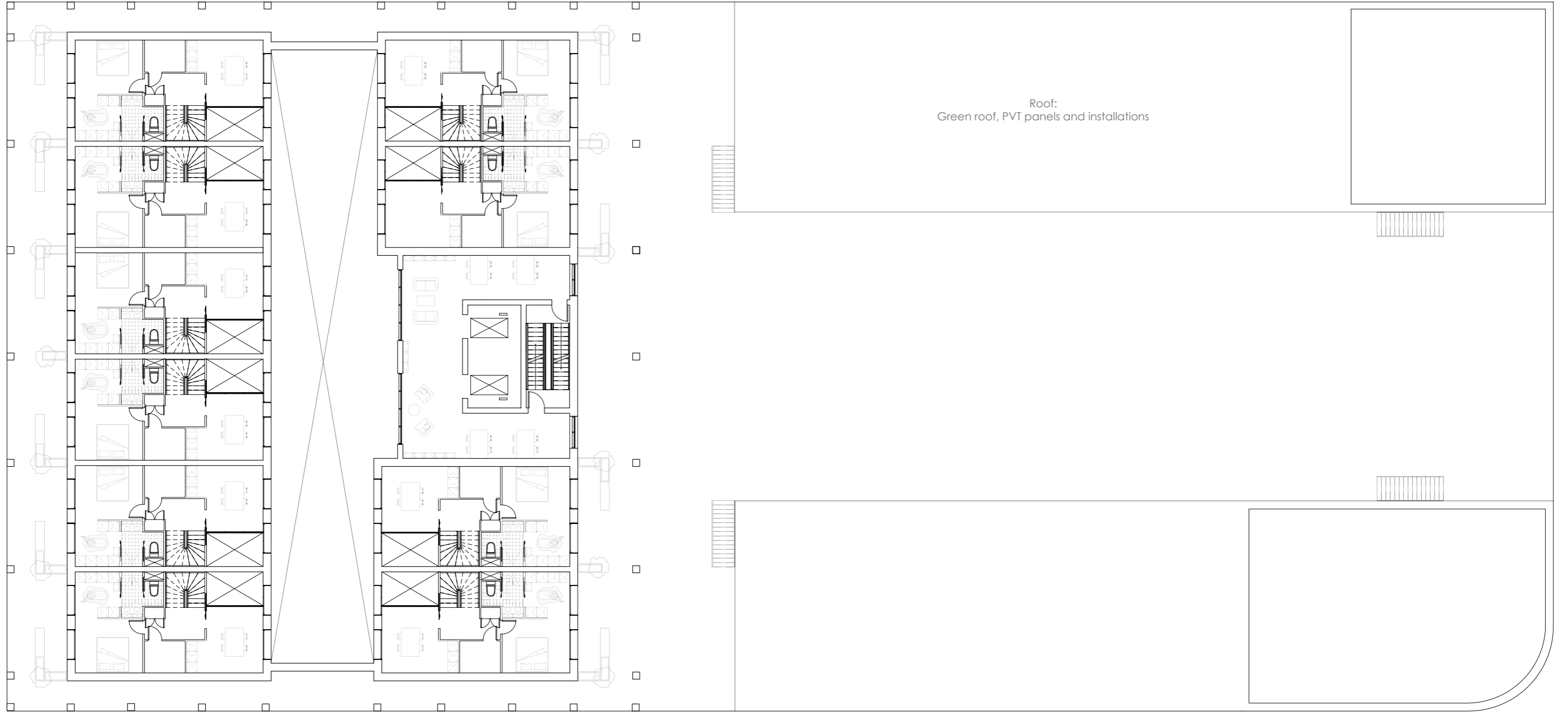

0 2.5 7.5 12.5m

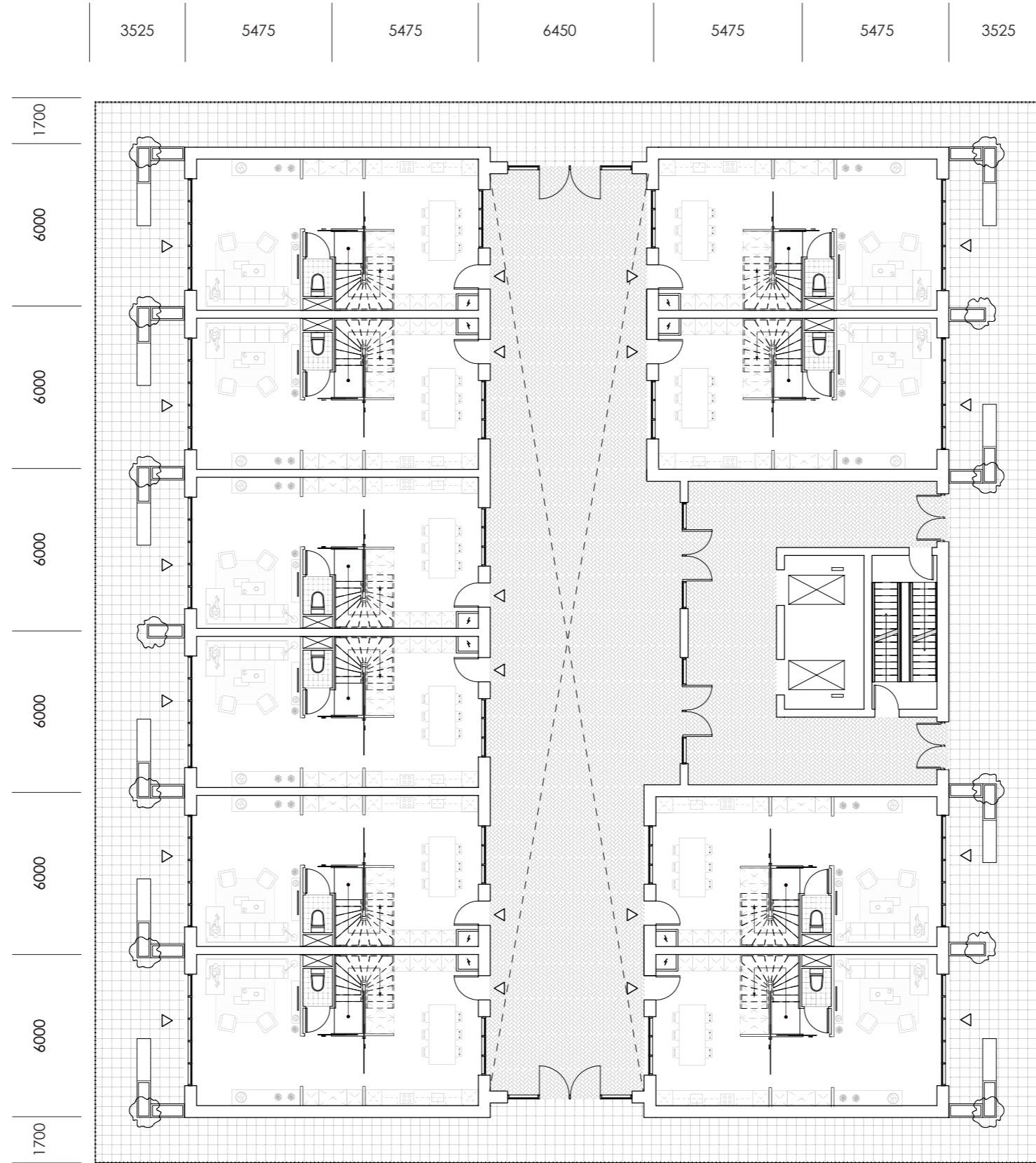
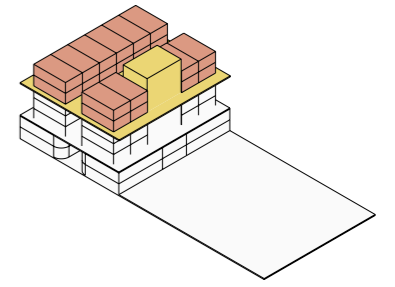

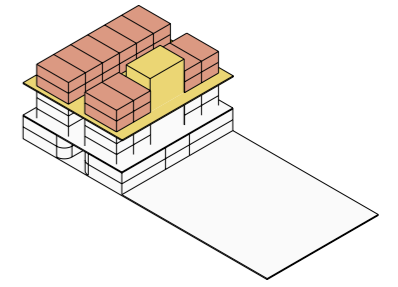
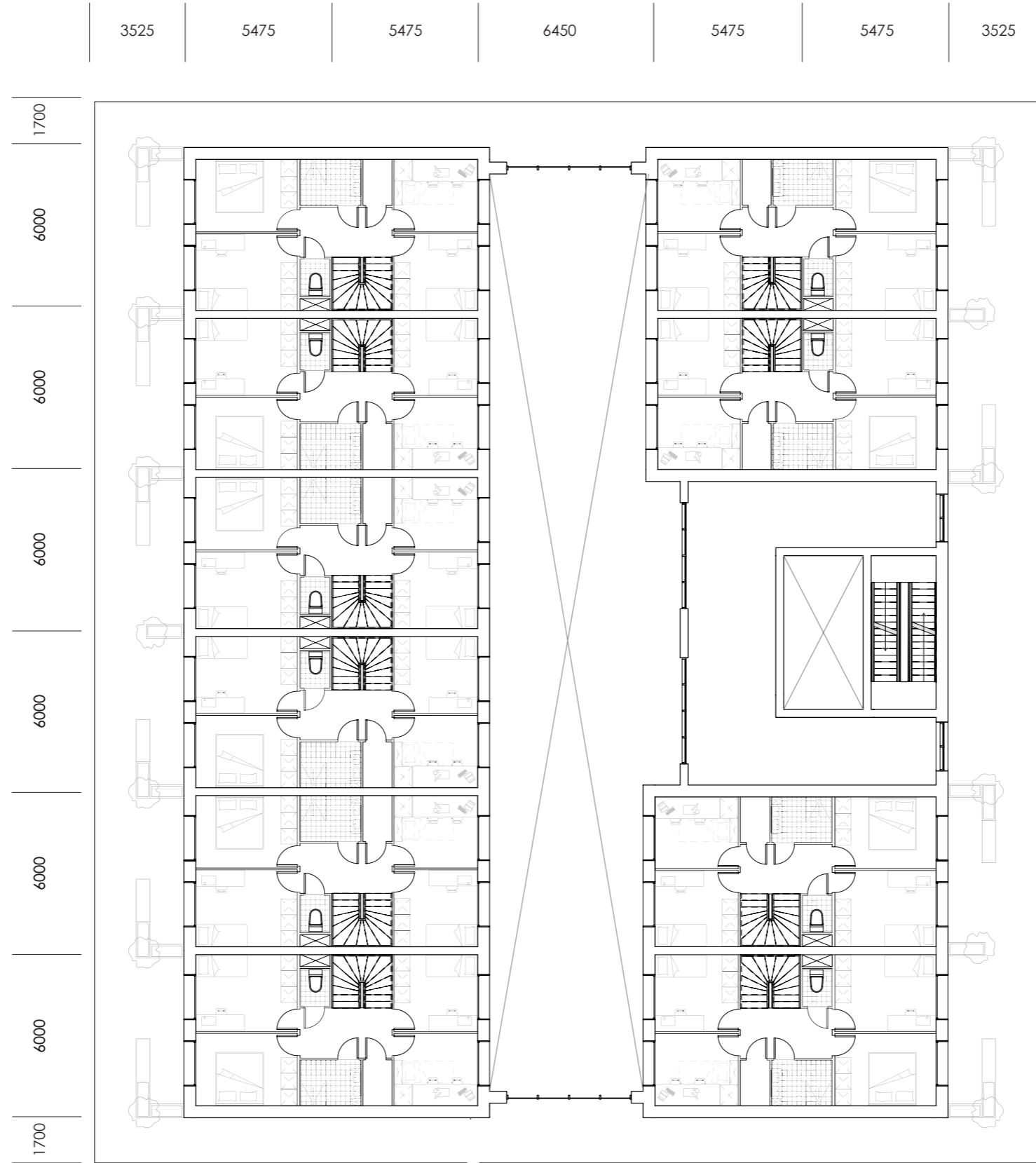



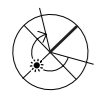
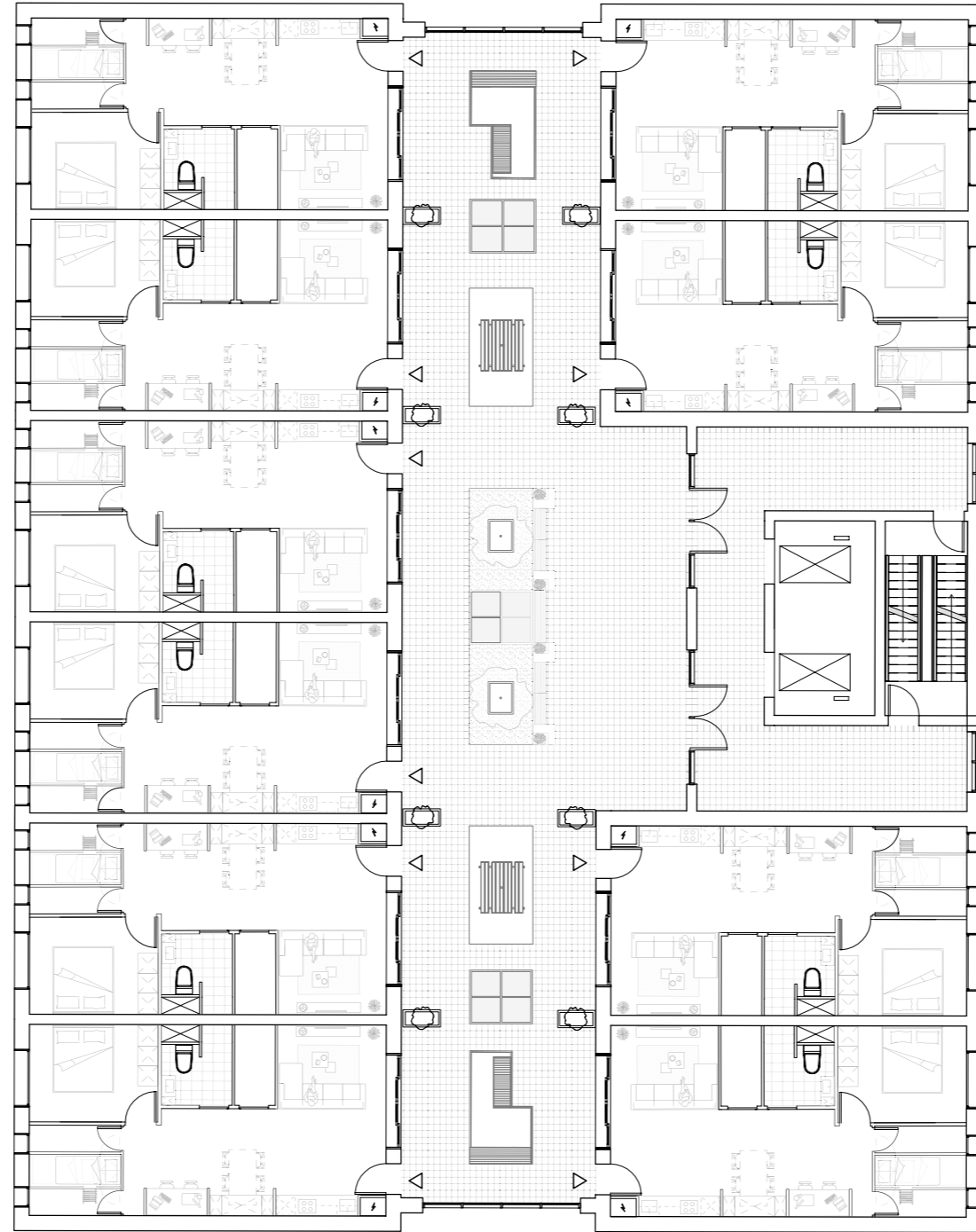
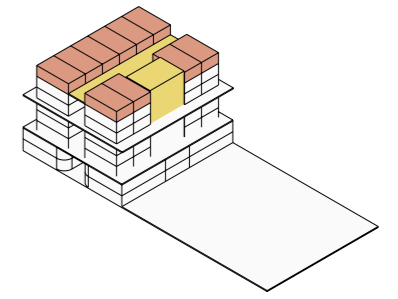

0 2.5 7.5 12.5m

△ Live - entrance

Contextual Materiality



Brick with vertical **(concrete)** column aligned with **wooden** window frame



Two tone brick and sliding panel with dark green window frames



Brick with vertical **(concrete)** lines aligned with **wooden** window frame



Metal container with vertical pattern.
Corntenstaal: warm appearance



Square patterned brick and **aluminium** panels (vertical)



Two tone brick - dwelling behind the dike

PATTERNS

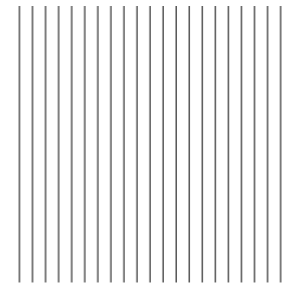
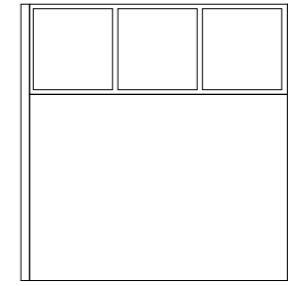
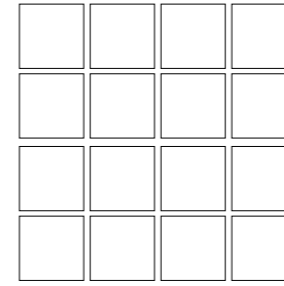

PALETTE



South Facade



West Facade



Aluminium paneling and window



Aqua Grijs Zwart WF - Kameleon collectie



Aluminium rainwater pipe

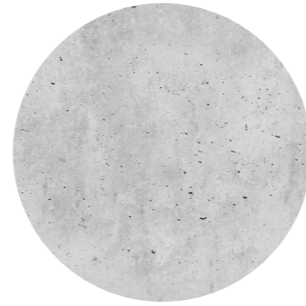

Concrete penants



I-Profile





North Facade



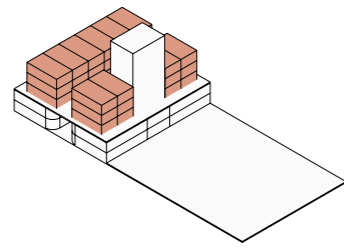

Unit A1 (03 levels)
Amount: 10
Area: 179.5m²

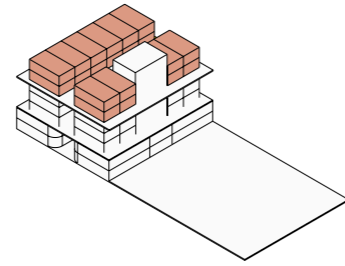

Unit A2 (02 levels)
Amount: 10
Area: 119.7m²

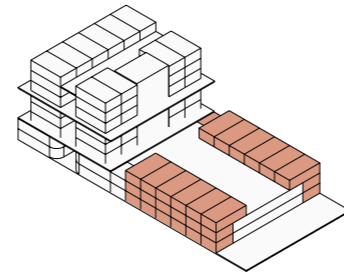

Unit B (03 levels)
Amount 12
Area: 120.5m²

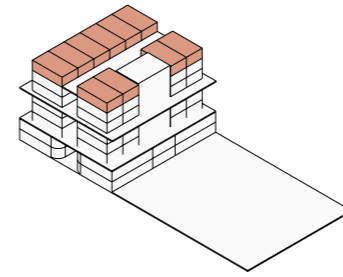

Unit C1
Amount: 10
Area: 59.4m²

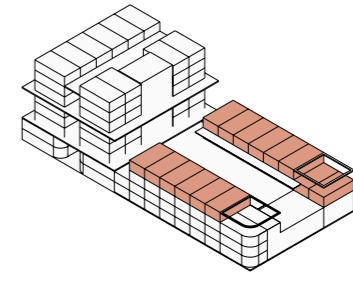

Unit C2
Amount: 14
Area: 59.85

Modern nuclear family

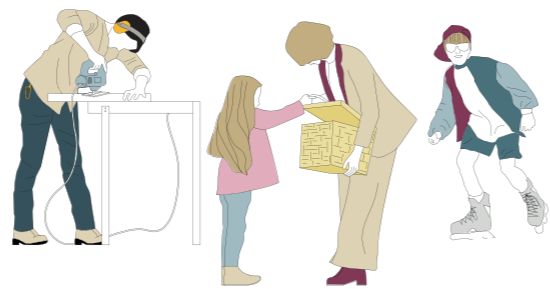

Single parent with toddlers

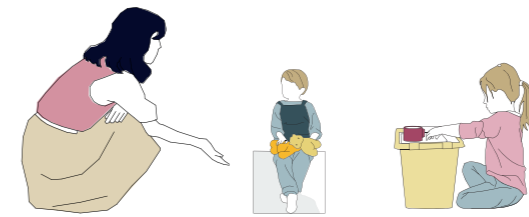

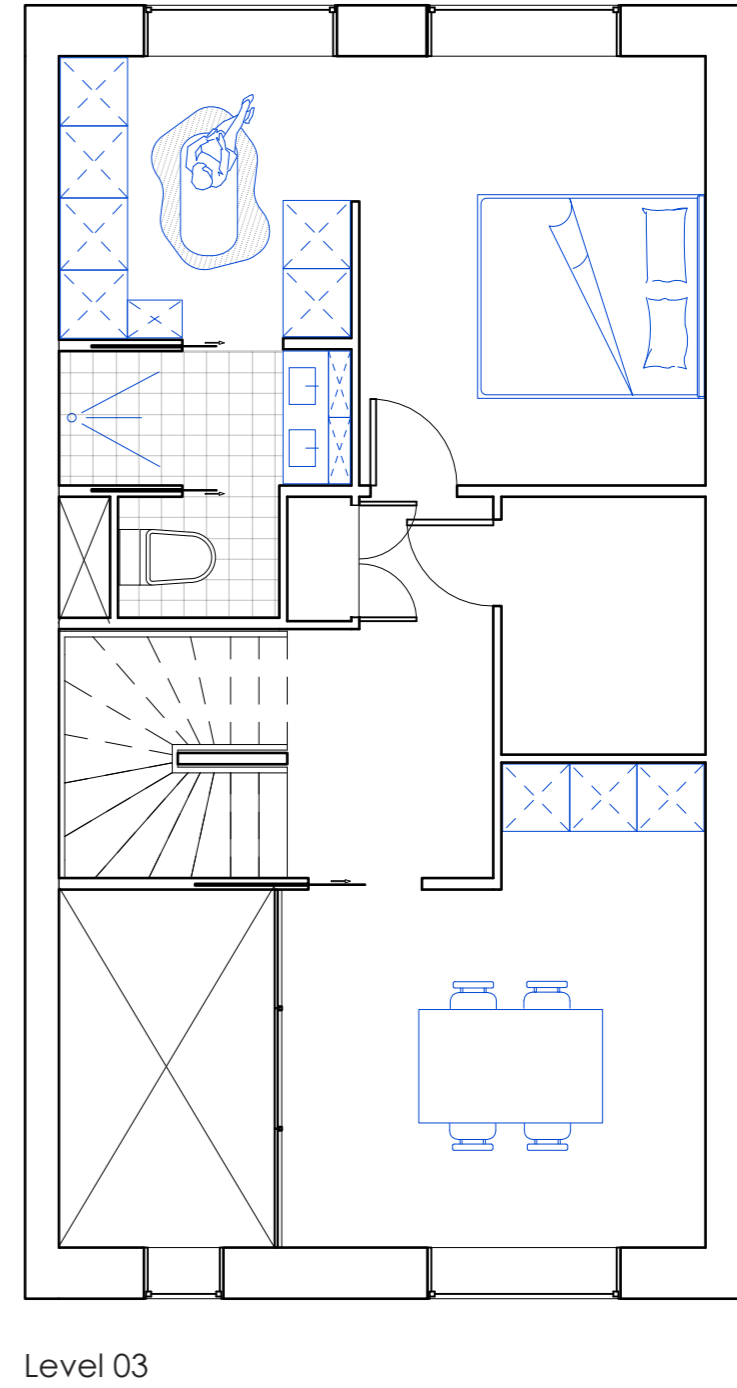
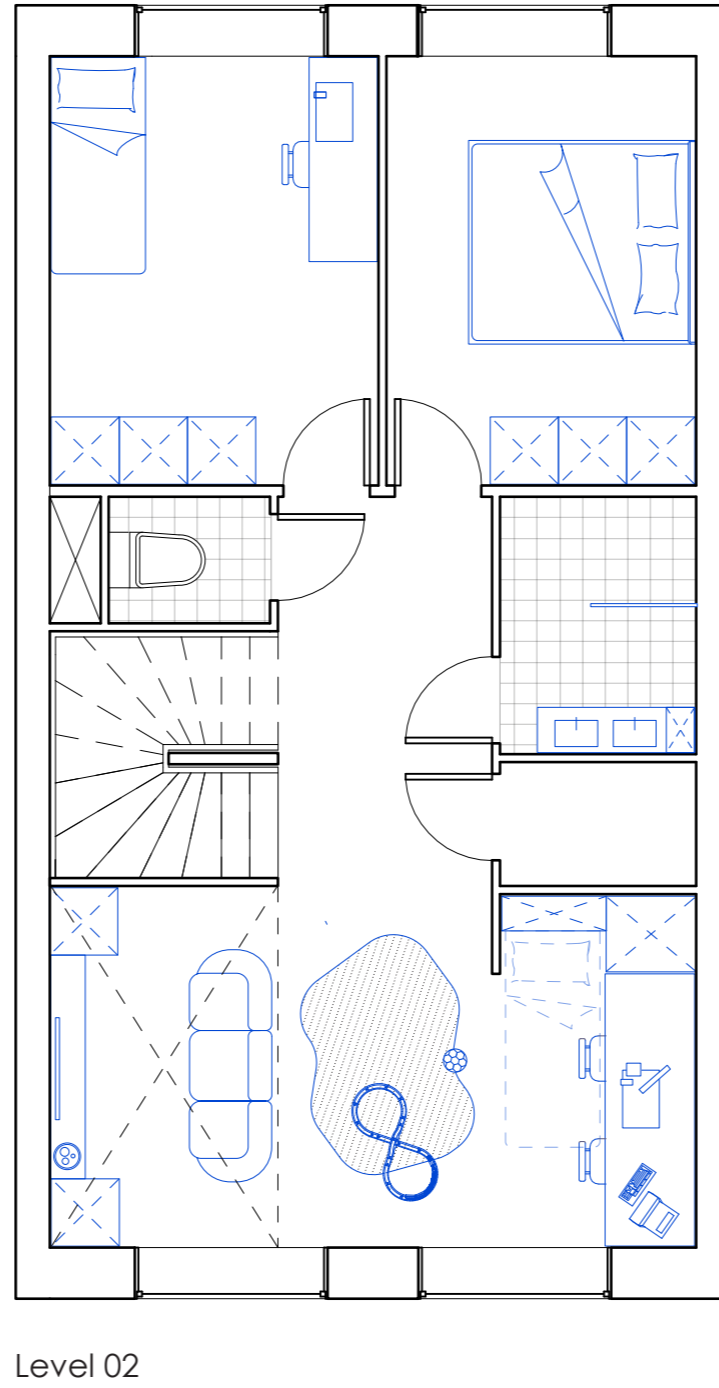
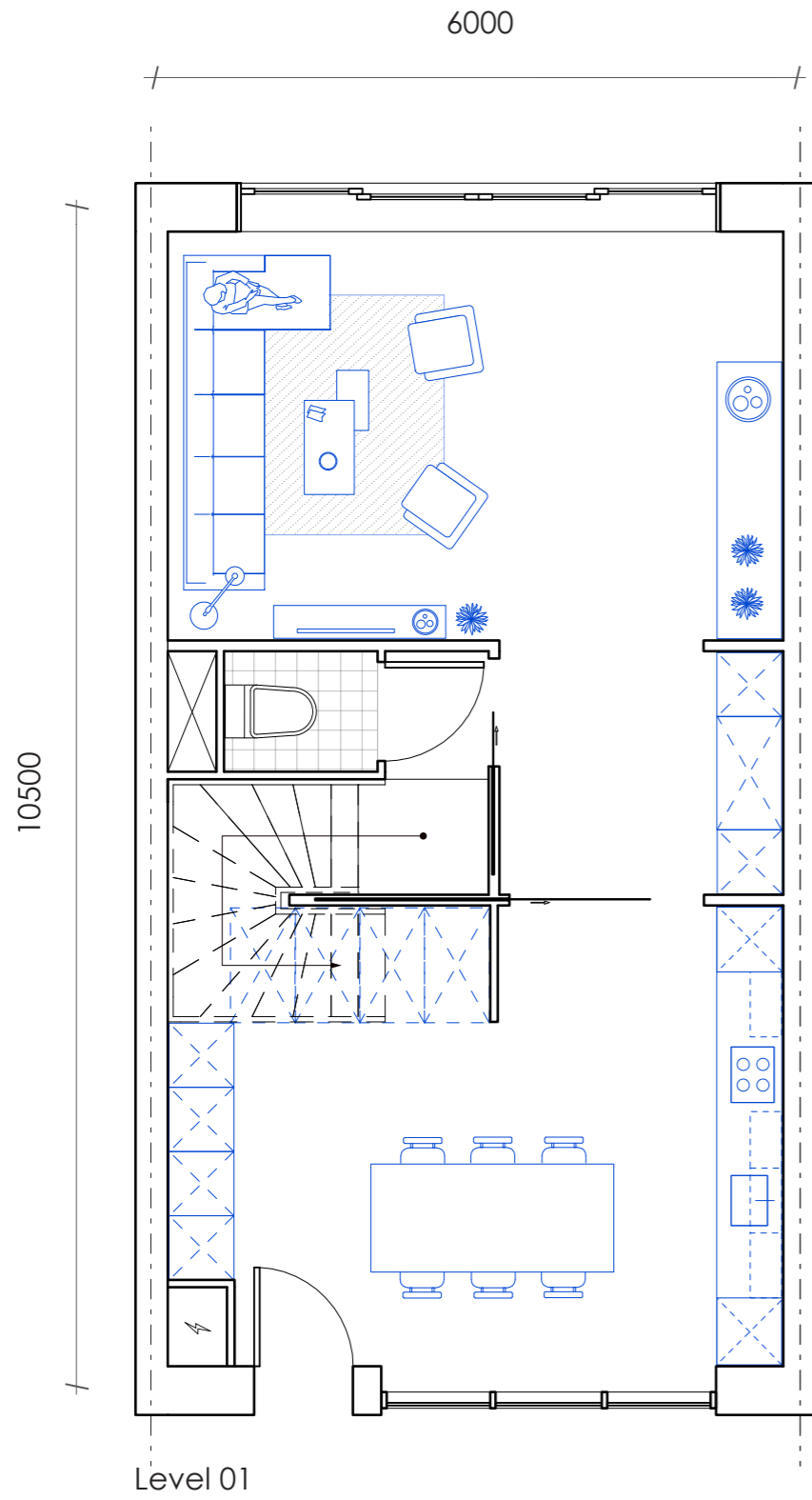



TI 196
klo 10.00
MA 25.6
klo 13.00
TI 3.7
klo 14.00 DO
TUE
J B

klo 13.00
TI 3.7
klo 14.00

DO
THE
JOB

EASY
LIVE
YOUR
LIFE



Unit C

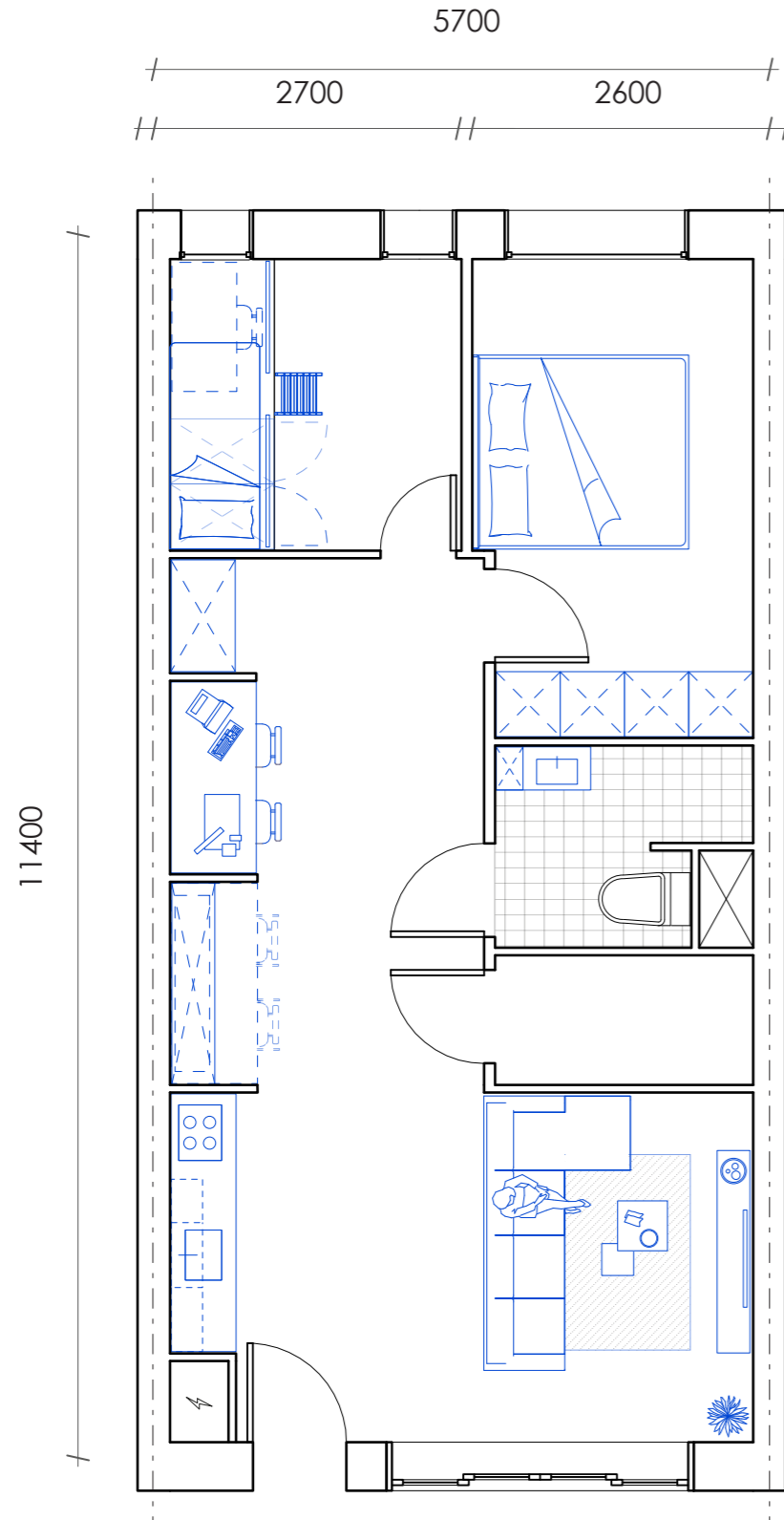

Stacking of bed and desk (Bunkbed)

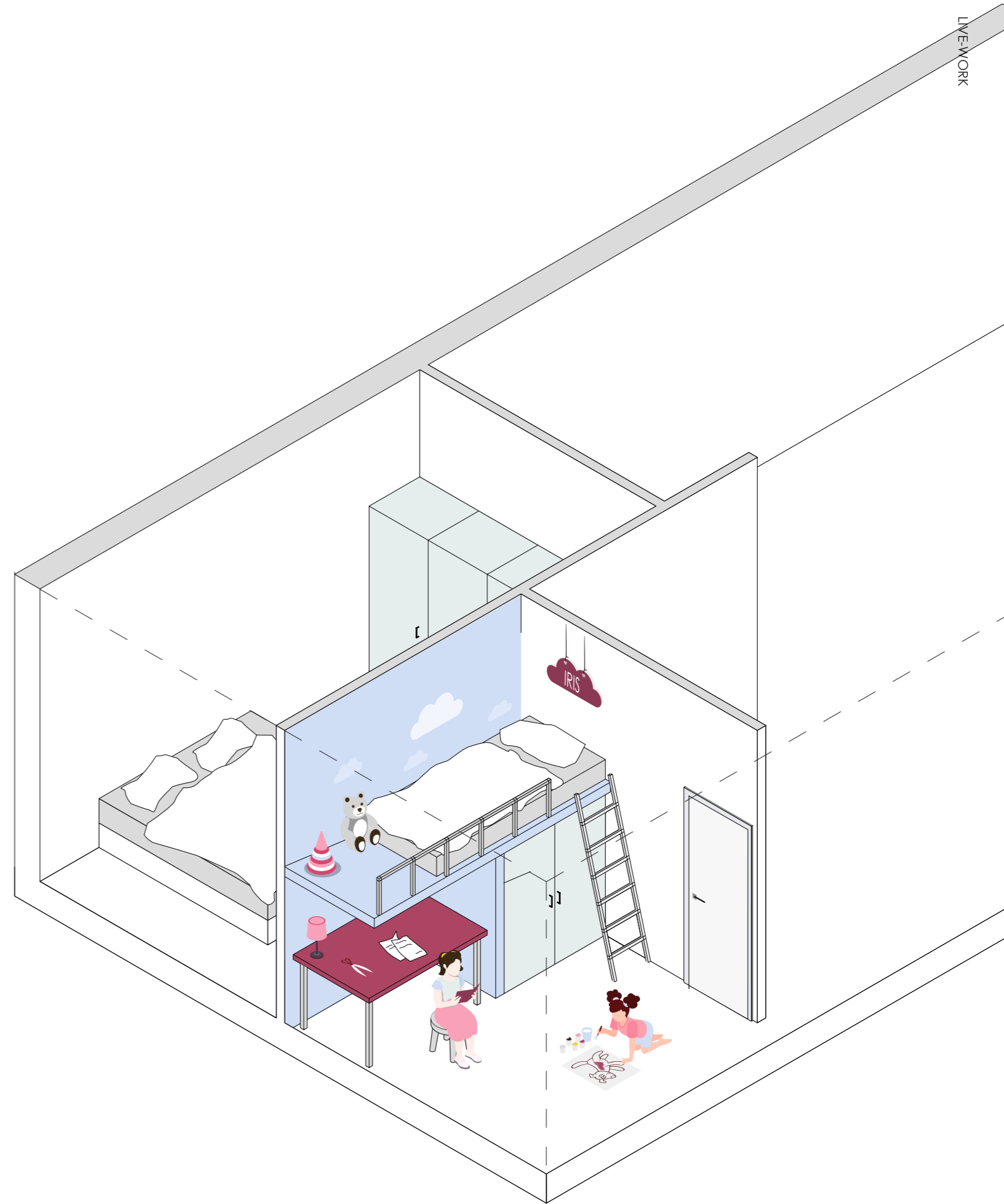

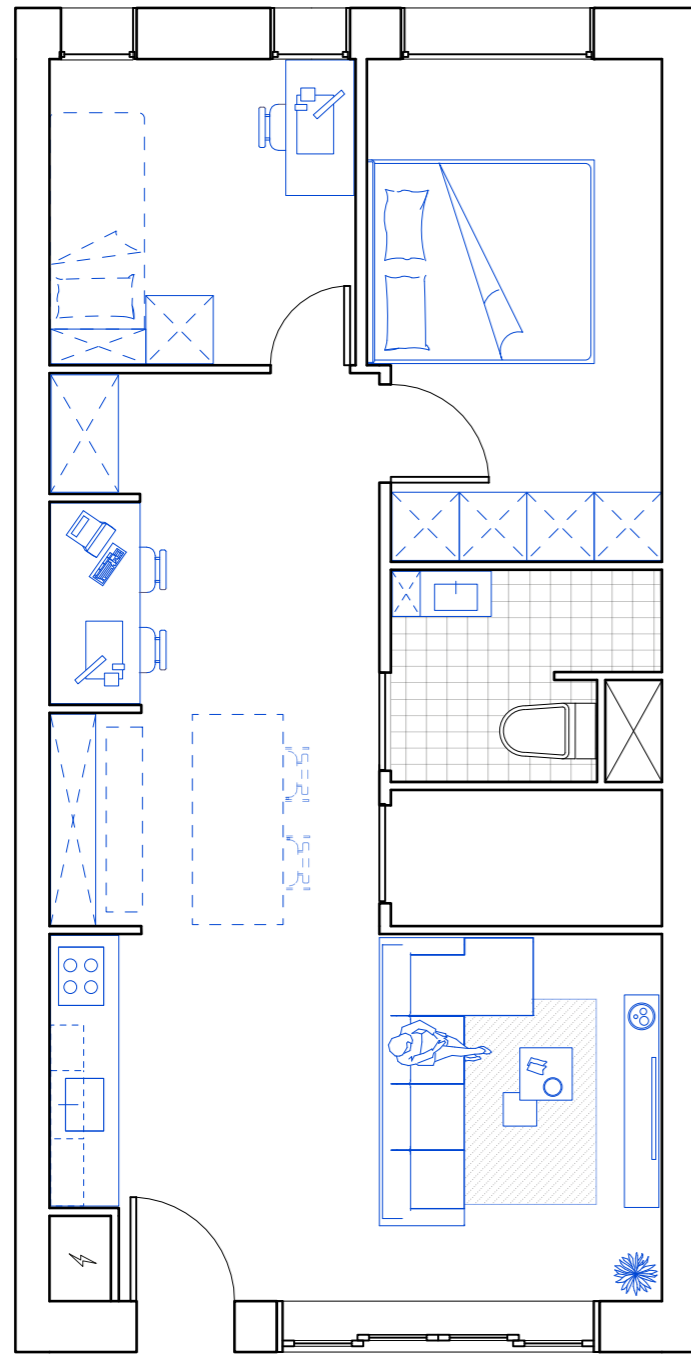

Murhpey bed and workspace

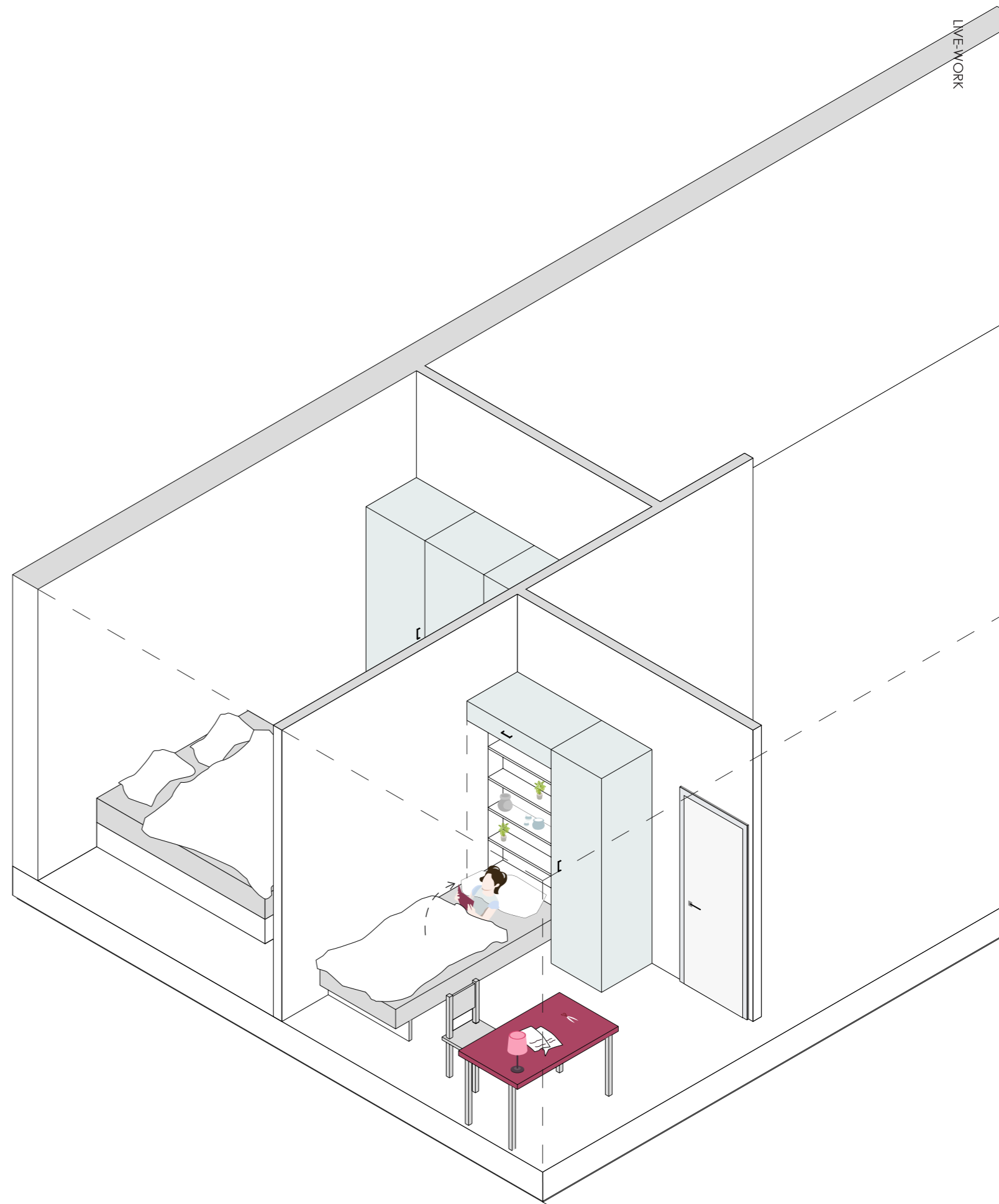

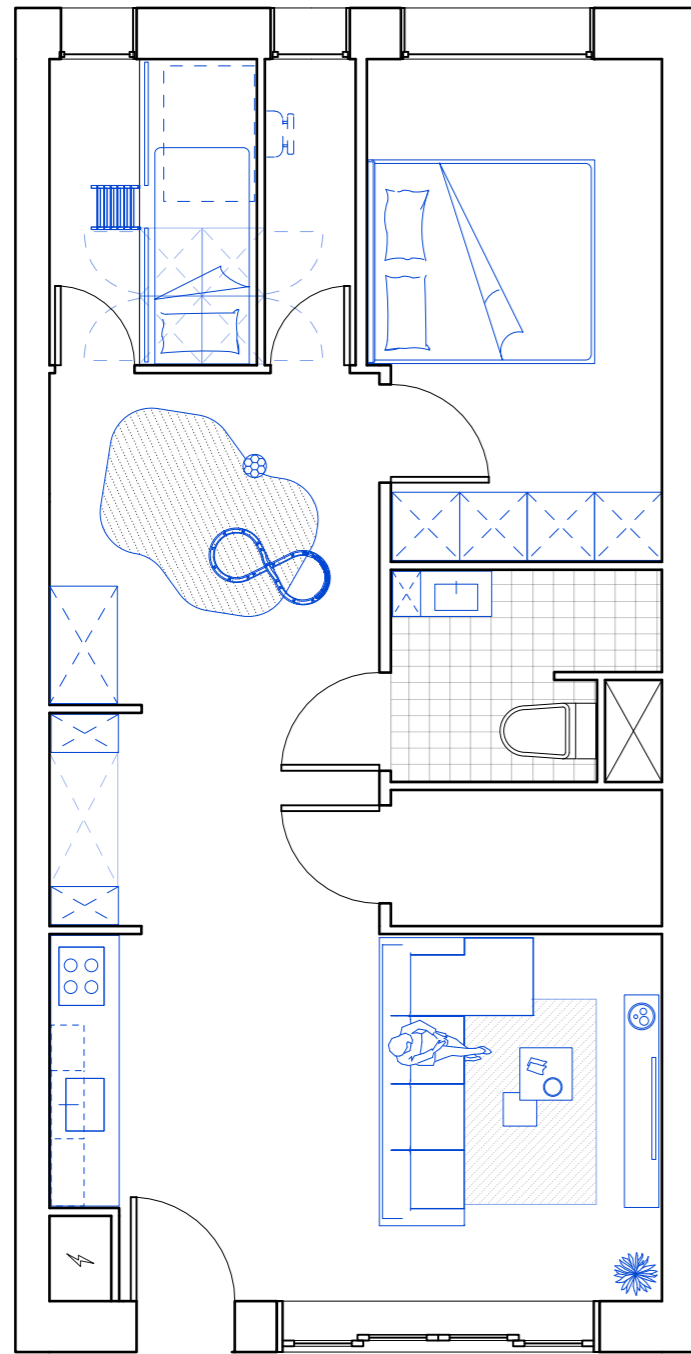

Stacking of bed and desk **in two separate spaces**

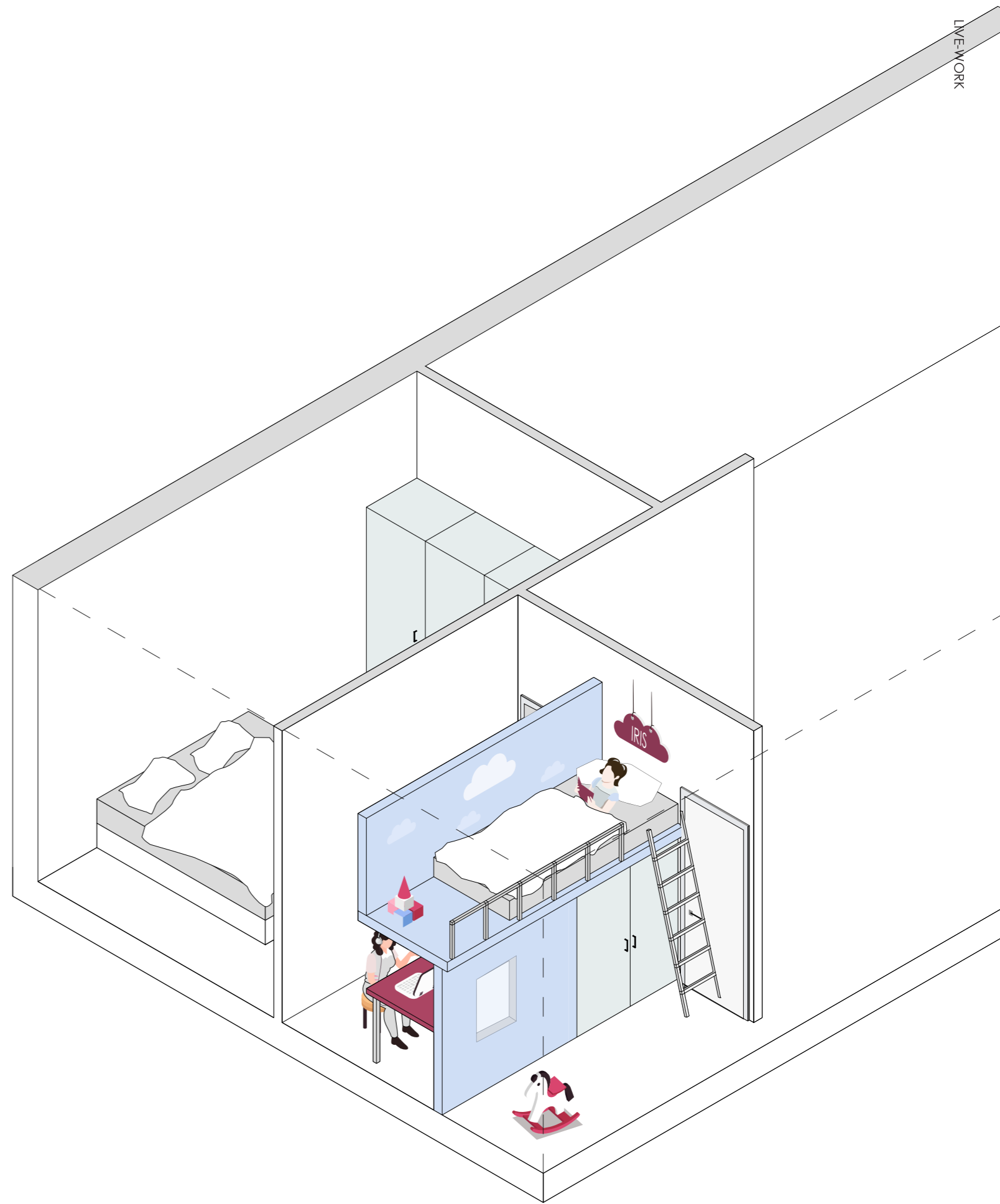

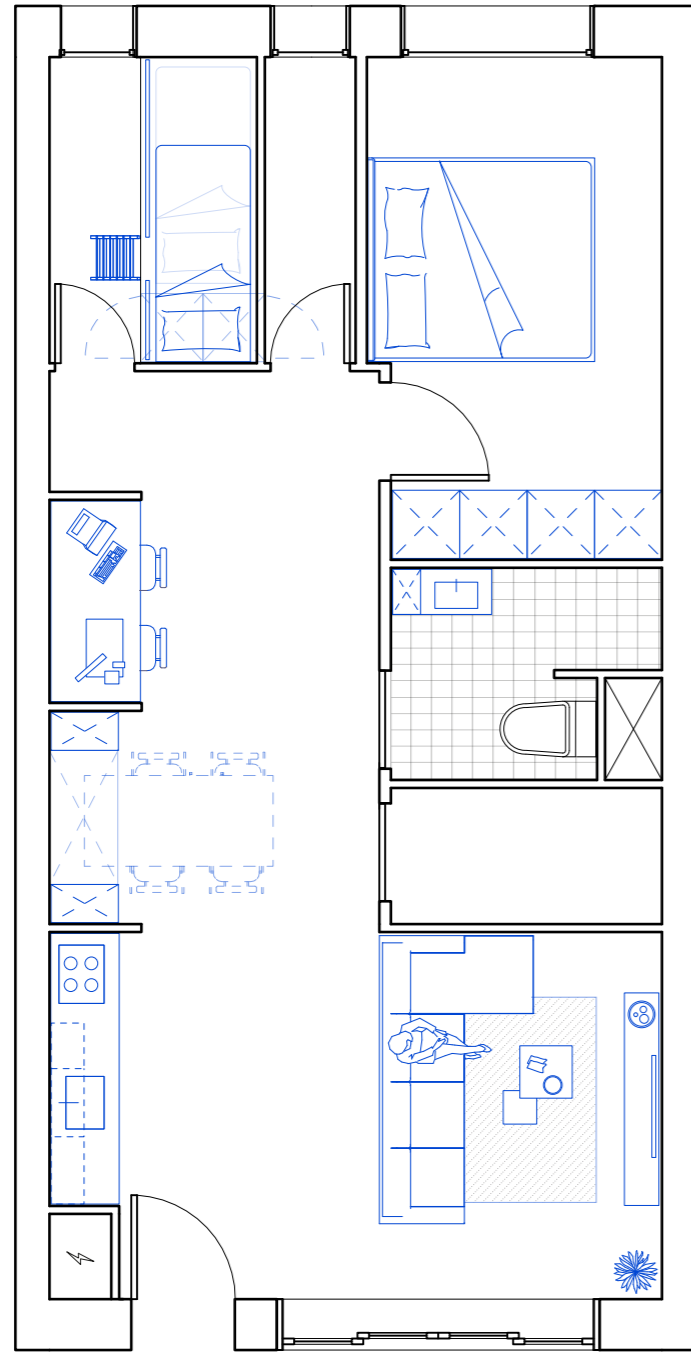

Stacking of bed and desk **in two separate spaces**

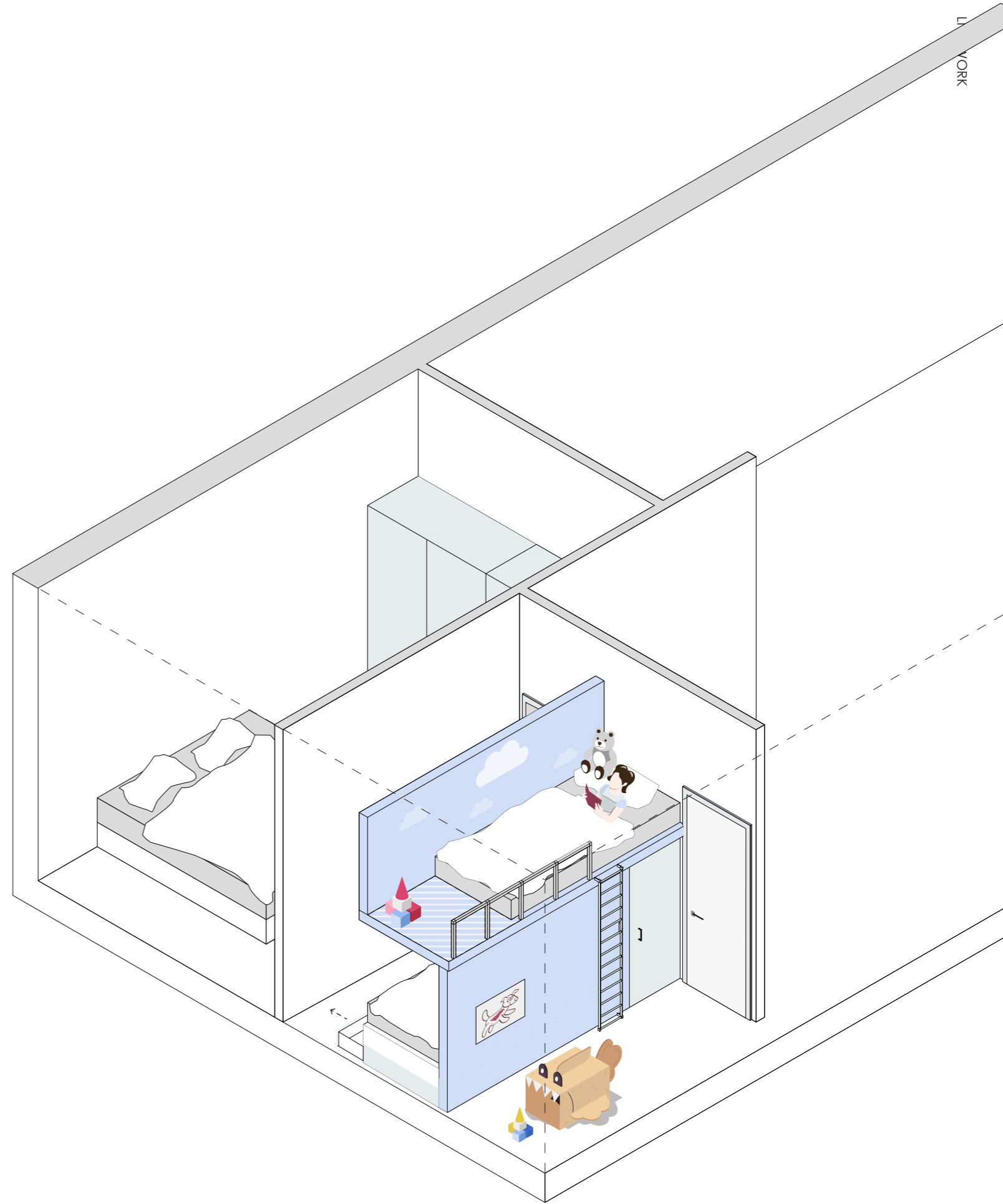

Facade fragment

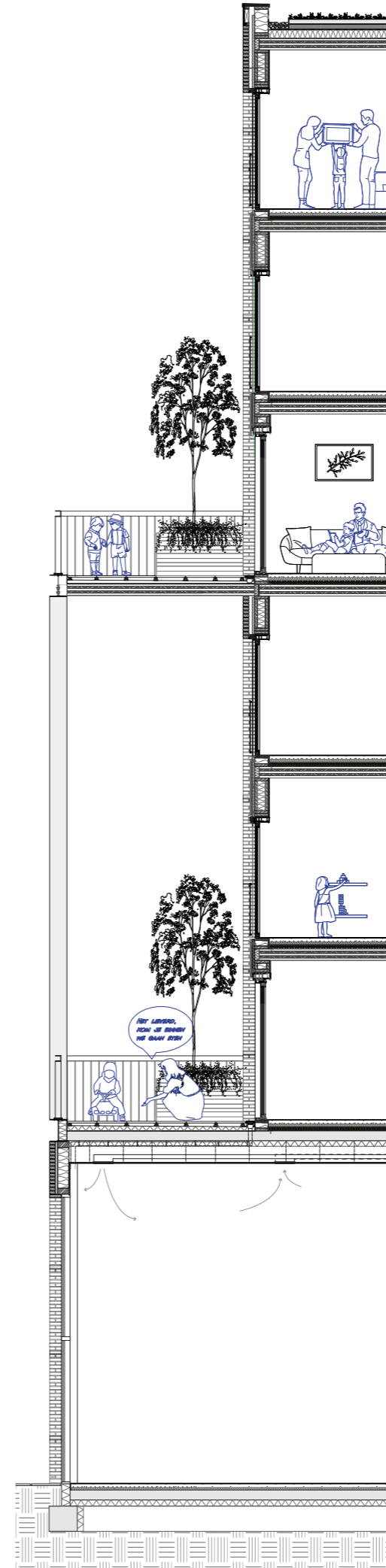

Scale 1:100

Facade fragment



Scale 1:50

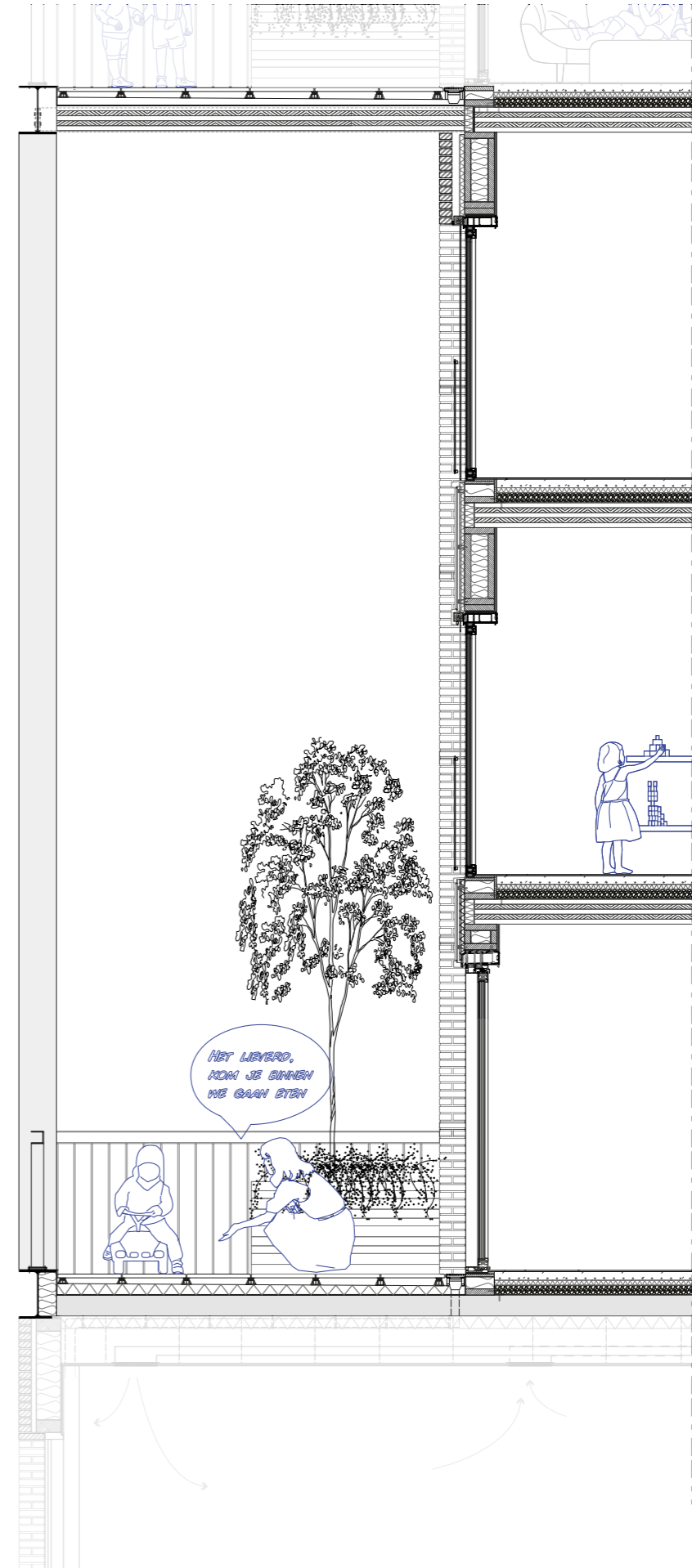

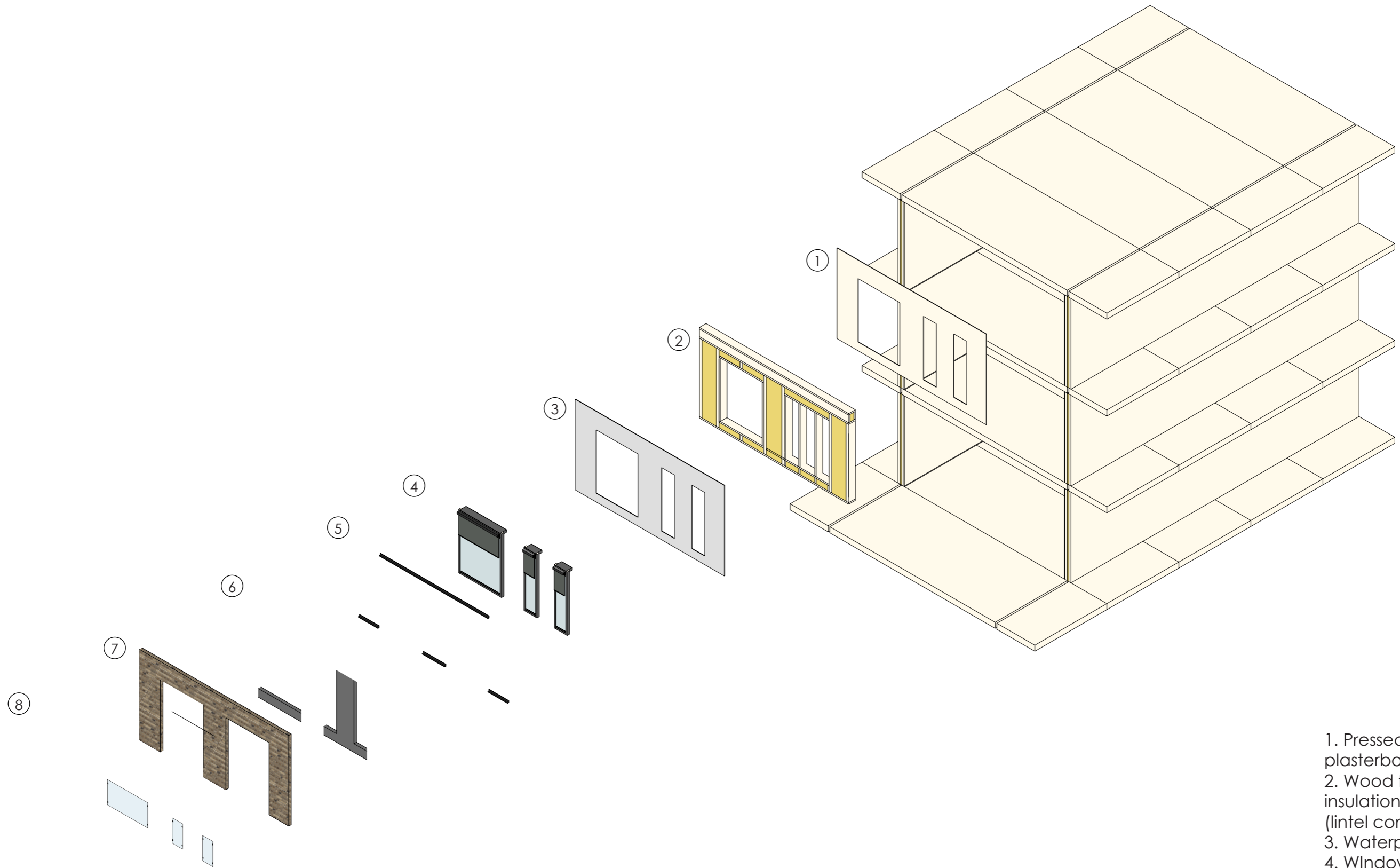

1. Pressed wood and plasterboard
2. Wood frame with insulation (lintel construction)
3. Waterproof membrane
4. Windows and screen
5. Brick lintel
6. Aluminium cassette cladding
7. Brickwork
8. Window fall protection

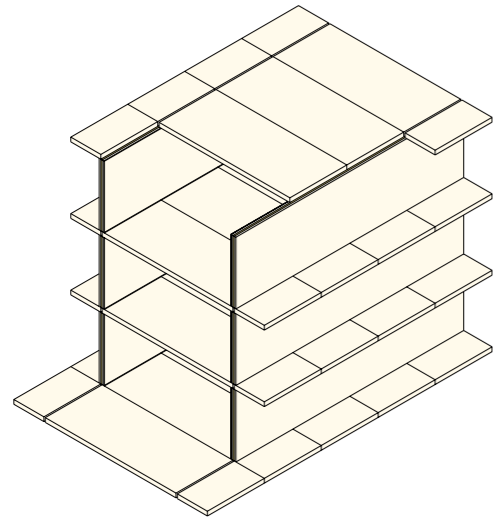

① Build up CLT floor and wall construction.

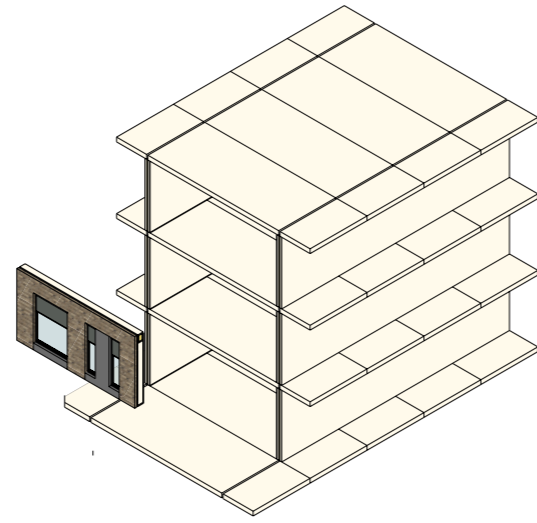

② Placement of the facade and connection it to the floors.

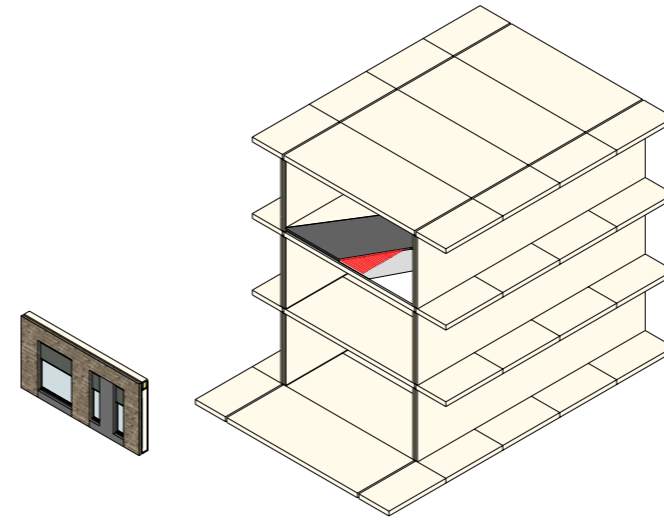

③ Building up the floor (choices made by designer)

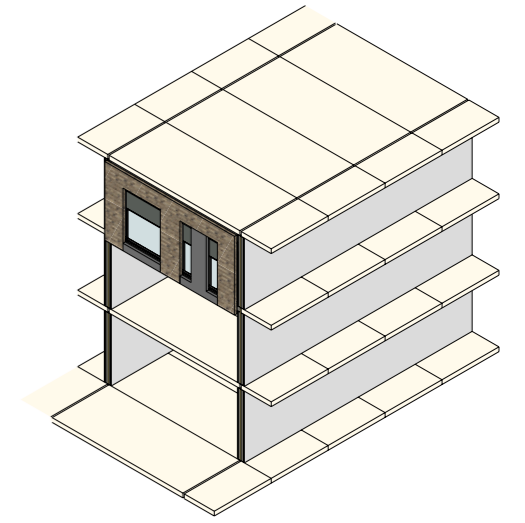

④ Add additional isolation layer and plasterboard for acoustics and fire protection.

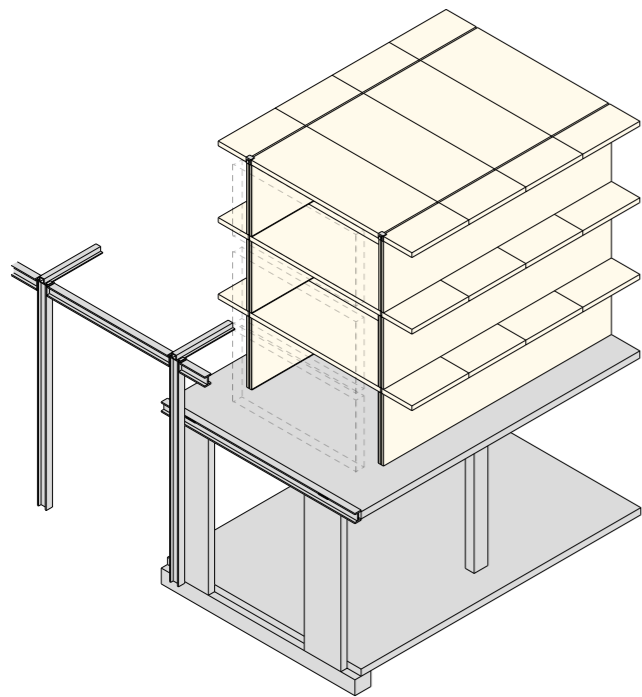

⑤ Connect facades to construction

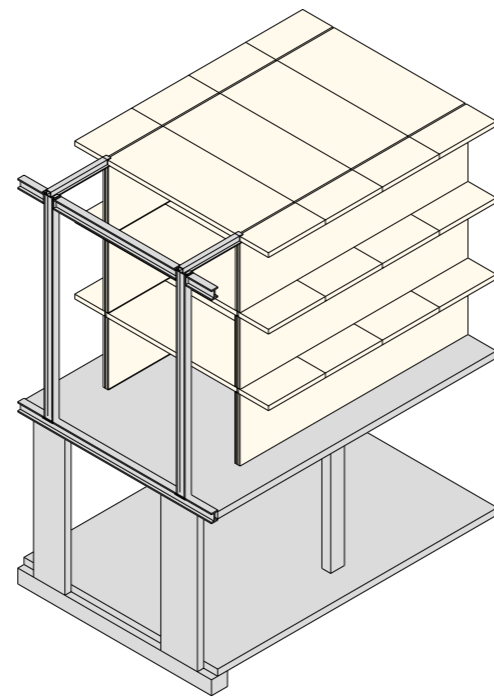

⑥ Build up the circulation construction after placing the facade.

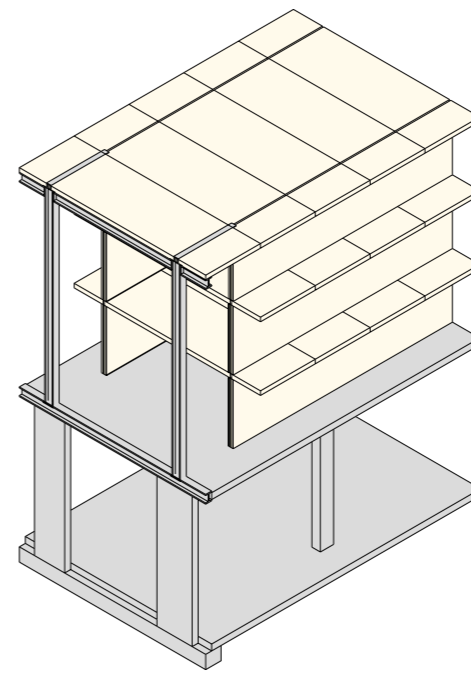

⑦ Place CLT floor between THQ beams (span direction).

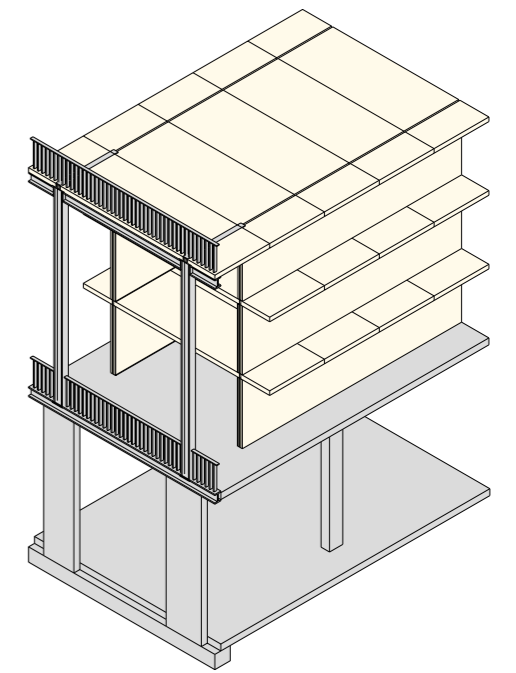

⑧ Placement of railing after all floor layers are stacked.



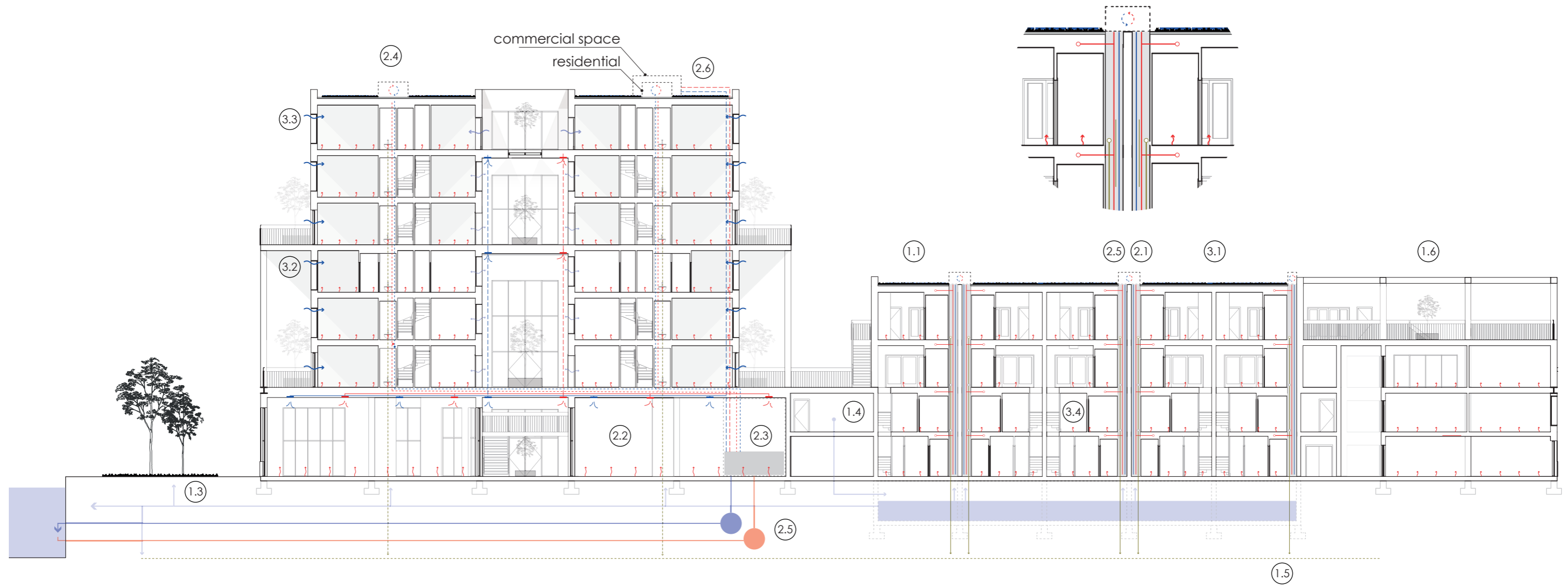

Rainwater management:

- 1.1 Rainwater absorbed by the green roof
- 1.2 Excess water drained along facade/shafts and collected in the basin
- 1.3 Re-use of filtered rainwater for irrigation of deck, flushing toilet, irrigation of public greenery, and in case of overflow direct excess water to Nieuwe Maas or sewage.
- 1.4 Re-use filtered greywater of collective washing machines
- 1.5 Sewerage
- 1.6 Green deck and trees in building and public space to reduce heat island effect and increase biodiversity.

Ventilation system:

- 2.1 Natural supply and mechanical extraction for the residential program
- 2.2 Mechanical supply and extract for the commercial program
- 2.3 Heat pump
- 2.4 Mechanical extraction unit with heat recovery
- 2.5 Sewerage venting
- 2.6 Separation inlet and outlet ventilation for clean air (smell)

Heating and electric installations

- 3.1 PVT panels for heat and electricity
- 3.2 Sun shading (screen, trees & circulation construction)
- 3.3 Preheating fresh air in winter
- 3.4 Floor heating & cooling

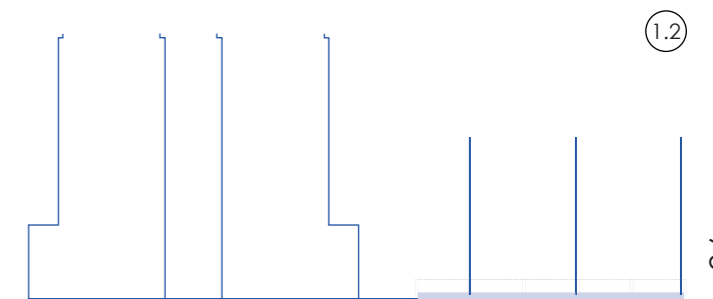

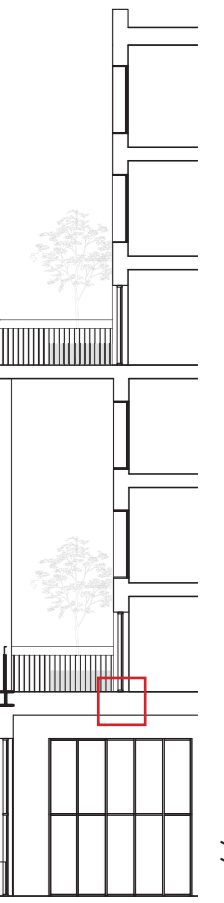
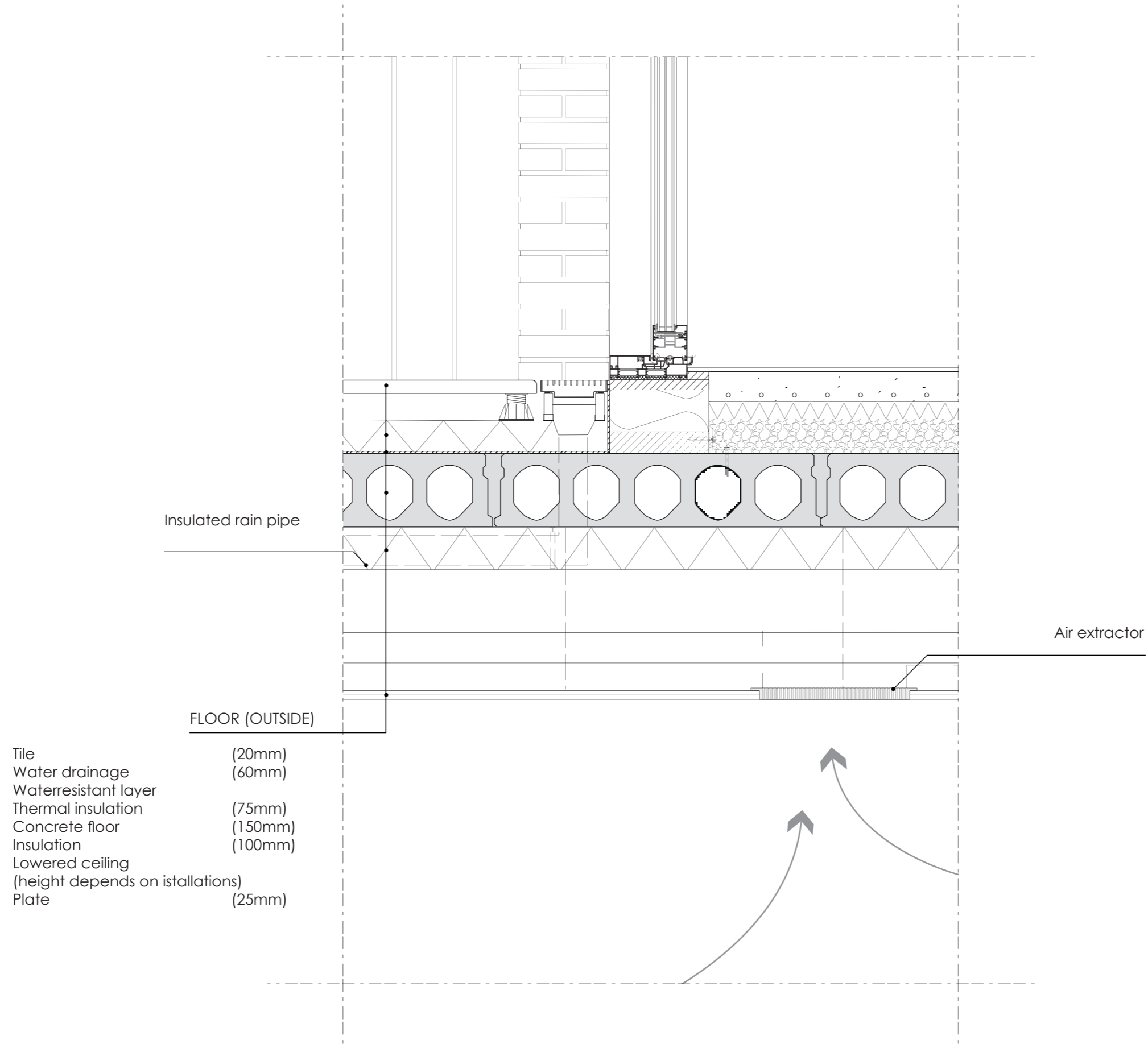

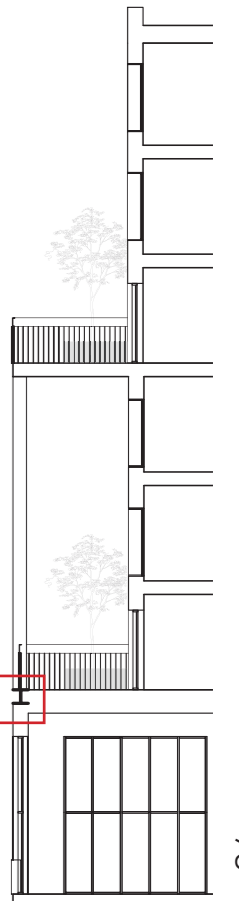
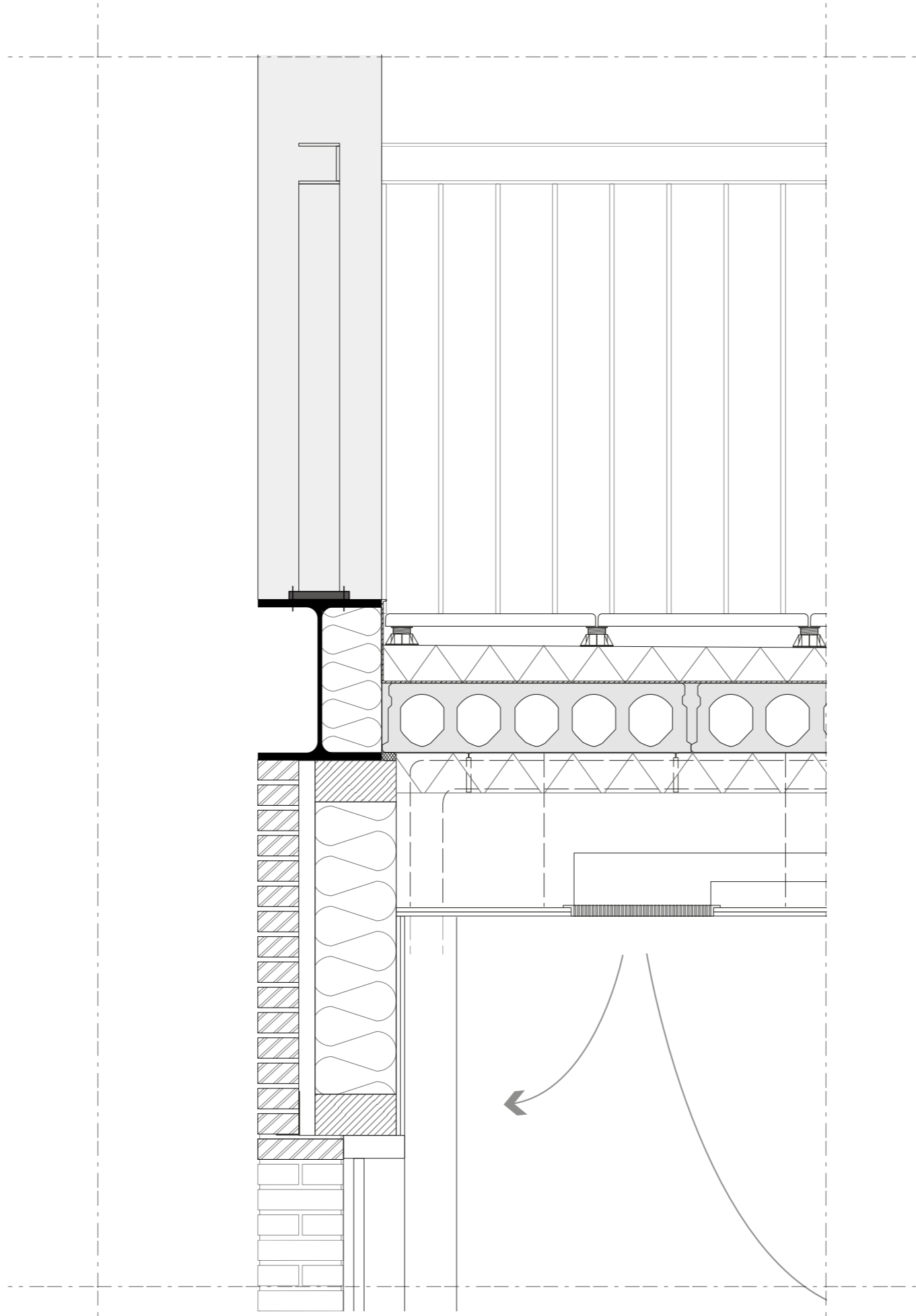

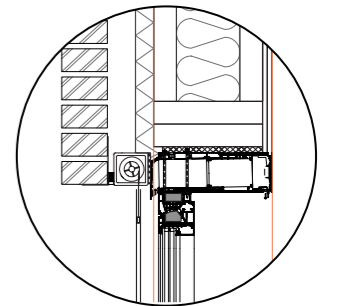
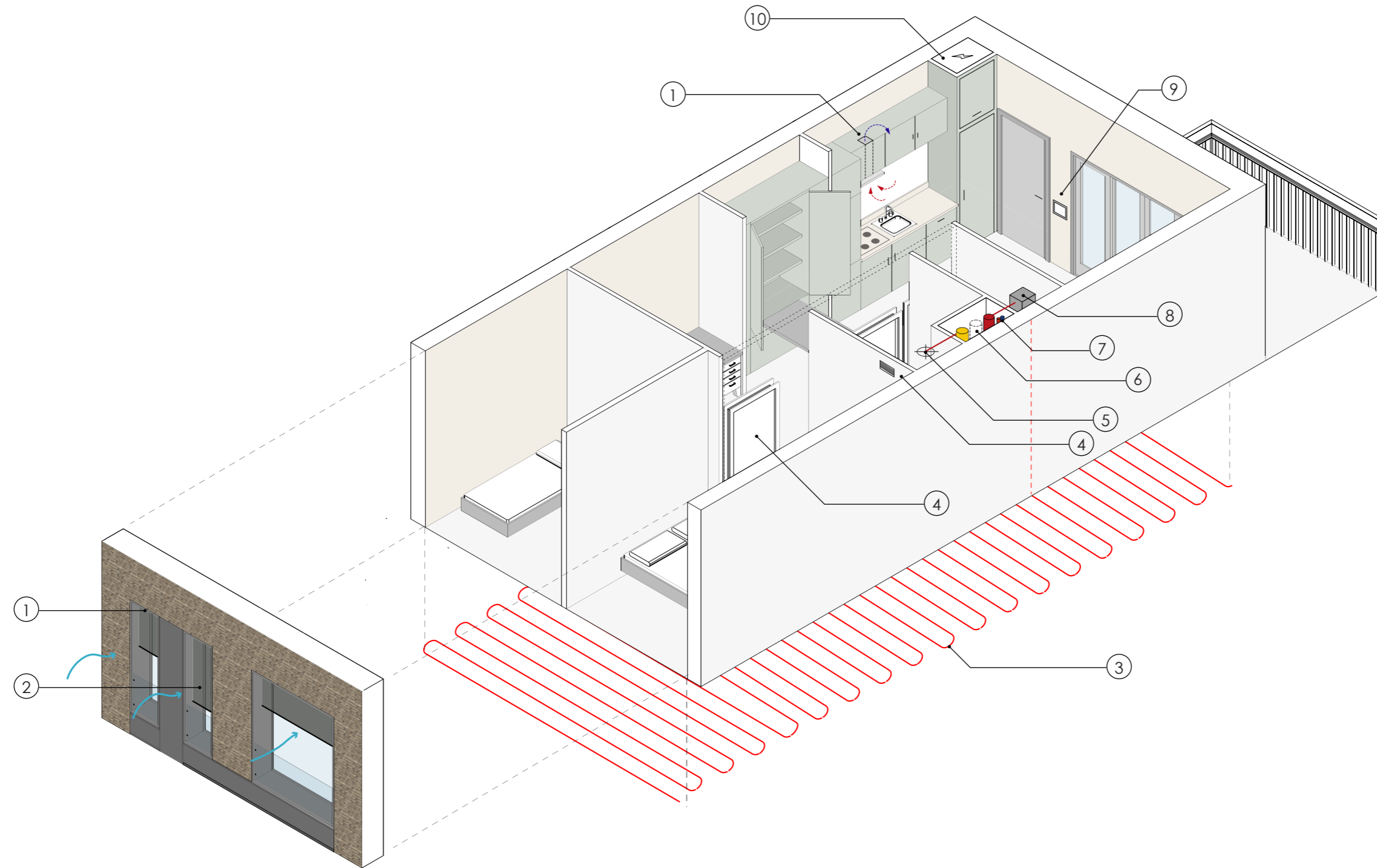

1. Schüco VentoTherm

- 1. Preheating fresh air in winter
- 2. Window screen for sun shading
- 3. Underfloor heating system and cooling grouped per space (verblijfsruimte)
- 4. Gap under door for ventilation or grill in wall for ventilation
- 5. Air extractor
- 6. Sewage
- 7. Hot/cold water
- 8. Unit Heating Pump/Boiler
- 9. Home control system (on demand)
- 10. Fuse box
- 11. Recirculation extractor

