

AT MY HOUSE I TAKE
THE WOOD UP TO MY ROOM.
FIND AT A TABLE, STALKING
THEM TO MAKE A NEW FOOD.

6 PM EVENING APPOINTMENT
WITH MY THERAPIST AS THE
CARS LINED UP TO THE
HIGHWAY ENTRANCE, LINE
OF RED TAIL LIGHTS

ED A REGULAR TO THE
BARBERS, DROPPED
BY TO SAY HELLO.
MENTIONED THE TOWER.
HE WORKS AT LONDON
LOOK AT MINI EXHIBITS
CLOSED, HE CAN SET
HOME WOOD IF I GET THERE
AT 5 PM

A COFFEE MEETING WITH STAVRO
BY THE STATION TO TALK ABOUT
THE PROJECT - OF ENHANCING
FLOW, OF WORD, TECHNOLOGY
(EMPLOYMENT) TOURS
AFFECTING OTHERS, FORMING
COLLECTIVES (ON THE SPECIFIC
MOMENT IT HAPPENS)

I ARRANGED
WITH LUK
HUIS TO BORROW
THE BOOKS,
KIM LET ME IN
AT 7 AM

I RETURNED LATE TO
LIVE HUIS. A PATH LEANED
SPACE OF NEARLY COYING
AND GOING, POPPING IN AND
LEAVING SOMETHING.
I WANT WITH ANNO, AGREEMENT
OF GOING UP, AND THE TALK
FINDS HE TALKS IN GERMAN
A GIVE, A RESEARCH, CLAIMING
SOMETHING, CLAIMING THE
RESEARCH AND LIFE OF OBJECTS

ED AND ALBERT LAY OUT
THE BEST LMS, I STAY IN LUK
LAW ROOM TO EAT THE MOST SPACE
THE LONG ONES STICKING OUT THE
TOP, BOOKS HEAT MEANS TAKING
AGES TO GO ONE METER

A SHIFT AT LES ZAAL. BOOKS
PARKED OUT FRONT, IM COVERED IN
MUD STILL FROM THE PREVIOUS NIGHT,
I WORK THE COUNTER WITH LIDIA AND
KENNAN, BUMPING INTO RILU AND
SISERINE, WHO LIKED THE TEXT I
WROTE AND WANTED TO JOIN THE
TOWER. ROOZBEH ALSO CAME FOR
COFFEE, WE CHATTED AND HE WILL
ALSO JOIN, AND WE MIGHT TRANSCRIBE
A CONVERSATION FOR HIS BLOG.

03:00

01:30

00:00

23:00

THE GROUND SEEMED SOFT ENOUGH AGAIN TO ATTEMPT TO HAMMER THEM IN THE GROUND DIRECTLY. AND NOW WITH A CAP OF TREATED WOOD DRILLED TO THE TOP OF THE PILE, IT SEEMED WORTH A SHOT. BUT IT DIDN'T WORK, THE CAP SPLIT AT THE SCREW, THE PILE BEGAN TO SPLIT AND IT HARDLY WENT DOWN.

THE AUGER, WITH A DIAMETER SLIGHTLY LESS THAN THE PILE, COULD MAKE A HOLE EASILY IN THE PEAT, A TWISTING MOTION CUT INTO THE EARTH, CATCHING IT IN THE GRIPS TO PULL OUT EVERY THREE ROTATIONS. THE DEPTH OF THE AUGER WAS 60-70% THE LENGTH OF THE PILE. IT GAVE US A GOOD START AND STILL ALLOWED THE PILE ENOUGH FRICTION WITH THE EARTH

WITH A HOLE TO GO INTO, THE PILE ONLY NEEDED TO BE HIT DIRECTLY, FLATLY AND CONSISTENTLY - NOT HARD OR ON EDGE WHICH RISKS TO SPLIT THE PILE. IT WENT EASILY FROM THERE, AND WE PLAYED IN THE MUD WE MADE AT OUR FEET - TAKING TURNS DIGGING, HAMMOLING & LIFTING BLENDED TUBS. SOME POST HOLES HIT CLAY AND WATER SOONER THAN OTHERS, SOME SPOTS WERE SURPRISINGLY FILLED WITH STONES AND WE STRUGGLED TO FIND A GAP,

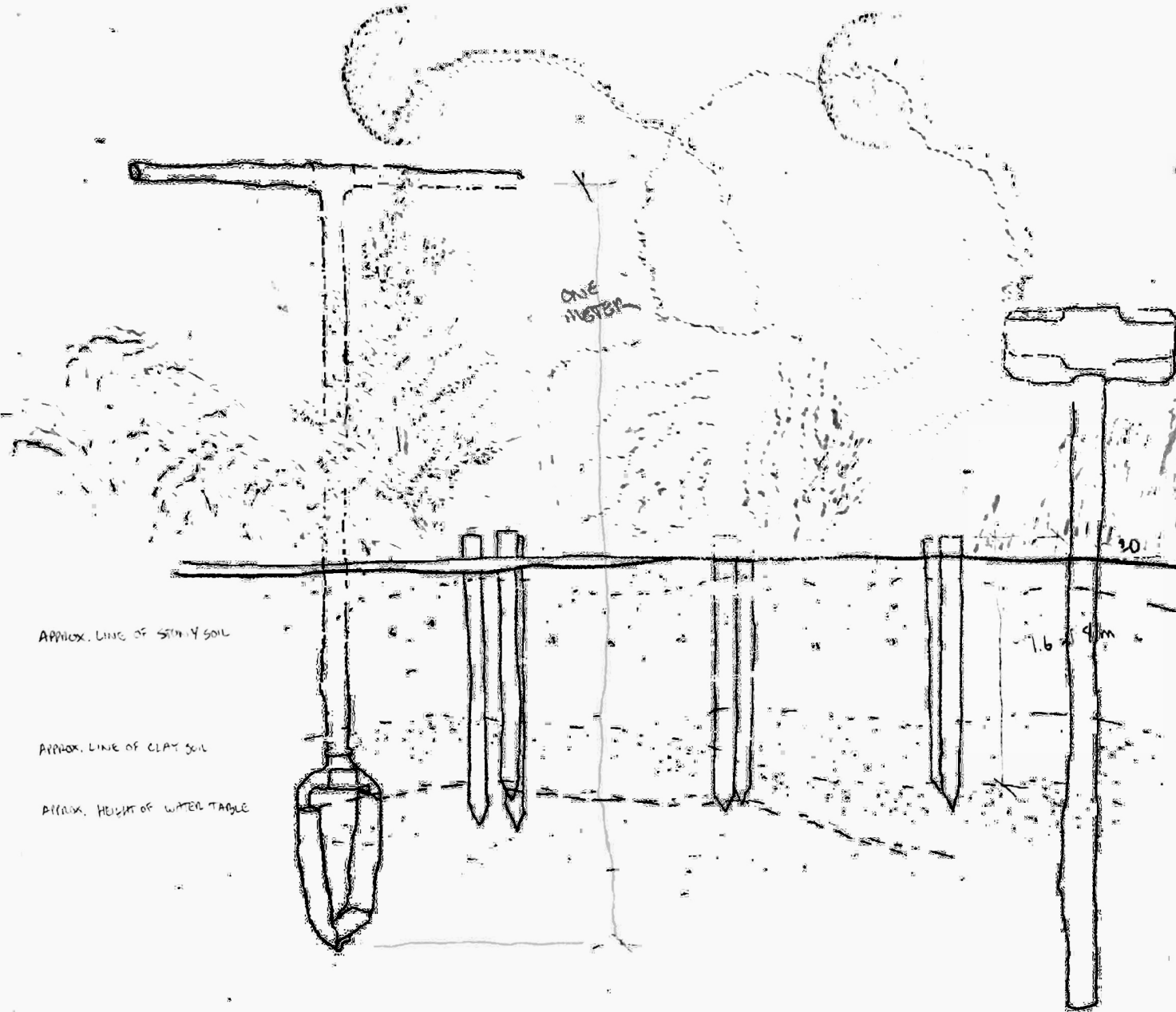

APPROX. LINE OF STIFF SOIL

APPROX. LINE OF CLAY SOIL

APPROX. HEIGHT OF WATER TABLE

ONE METER

1.6 m

THE FOUR OF US STOOD THERE IN THE COLD, LOOKING OUT AT THE LAKE, POSTS IN OUR HANDS, THE MOON HIGHLIGHTING THE TALL GRASS AND THOUGHT WE WERE TO PUT A TOWER.

NESTLED PARTLY INTO THE BUSHES, BUT STILL VISIBLE TO THE LAKE, THE SUN, - OPENING TO THE PATH - COULD THIS BE AN ENTRANCE? WILL THIS BE THE TALLEST PART? IS IT TOO EXPOSED IF WE ARE TOO FAR OUT INTO THE TALL GRASS? LET'S NOT ONLY DO RIGHT ANGLES, THIS FEELS RIGHT.

"I THINK IT'S A BIT FRAZT TO THINK WE SHOULD FIGURE OUT ALL THESE THINGS, SO DEFINITELY NOW LET'S GO WITH WHAT FEELS RIGHT AND LEAVE IT OPEN FOR THE NEXT THINGS WE DO."

"AND I'M COLD - LET'S JUST POUND THESE THINGS INTO THE GROUND."

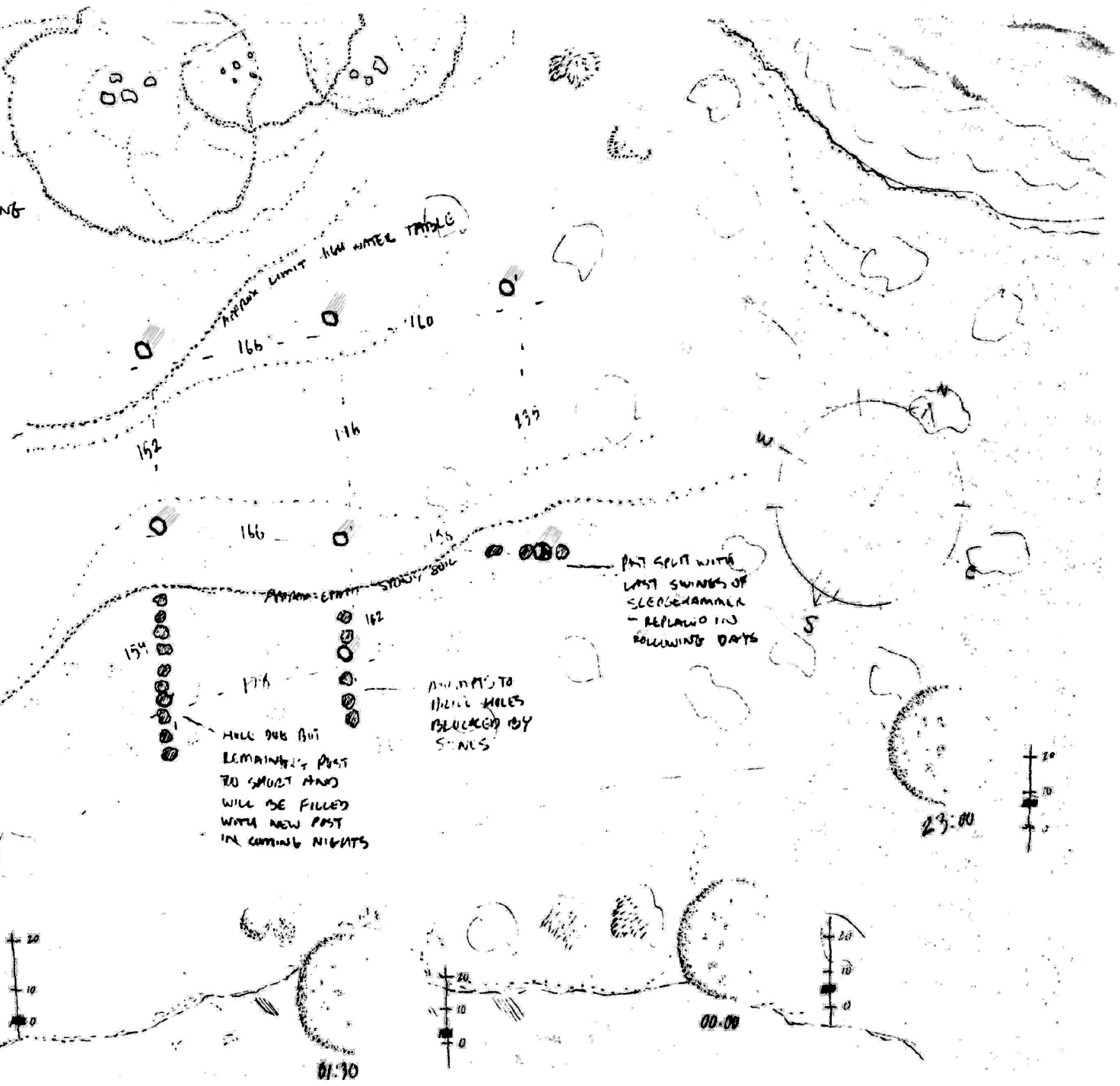

PNT SPILT WITH LAST SWINGS OF SLEDGEHAMMER - REPLACED IN FOLLOWING DAYS

HOLE DUG BUT REMAINING POST TOO SHORT AND WILL BE FILLED WITH NEW POST IN COMING NIGHTS

APPROXIMATE HOLE BLENDED BY SAILS



03:00

01:30

00:00

23:00

SOBREM. NETHERLANDS DEAT SOIL SUITS A POLE FOUNDATION - I MEAN IT'S NECESSARY - BUT ALSO GIVES AN OPPORTUNITY TO MAKE A CHEAP AND EASY FOUNDATION. I SCOURED FOR POLES AT SHOPS - TOO EXPENSIVE - I REMEMBERED AN UNATTENDED PILE OF LOGS IN AN EMPTY LOT BY THE MERWETHERVEN. THE PILES ARE DUMPED IN A MESS. I BEGAN SORTING THROUGH FOR STRONG PILES WITH A POINTED TIP - MANY TIPS ARE CUT OFF. I STRUGGLE TO CLIMB TO RETRIEVE GOOD PIECES FROM THE BOTTOM. I THINK THESE WERE USED TO HOLD UP YOUNG TREES IN THE CITY. THE SUN COMES OUT THROUGH THE CLOUDS AND WEATHER OVER THE HARBOR. IT MAKES A FUNNY RELUCTANT RED GLOW - I'M LATE FOR MY SHIFT AT LEES ZAAL.

I COME BACK TO GATHER THEM, CUT TO MY HEIGHT AND LUG THEM TO MY HUGE HELPER. SHE SEES MY STRUGGLE AND OFFERS HER VAN - I TELL HER I'M NOT SURE IF ITS ALLOWED, SHE DOESN'T MIND. THE RAIN IS GROWING

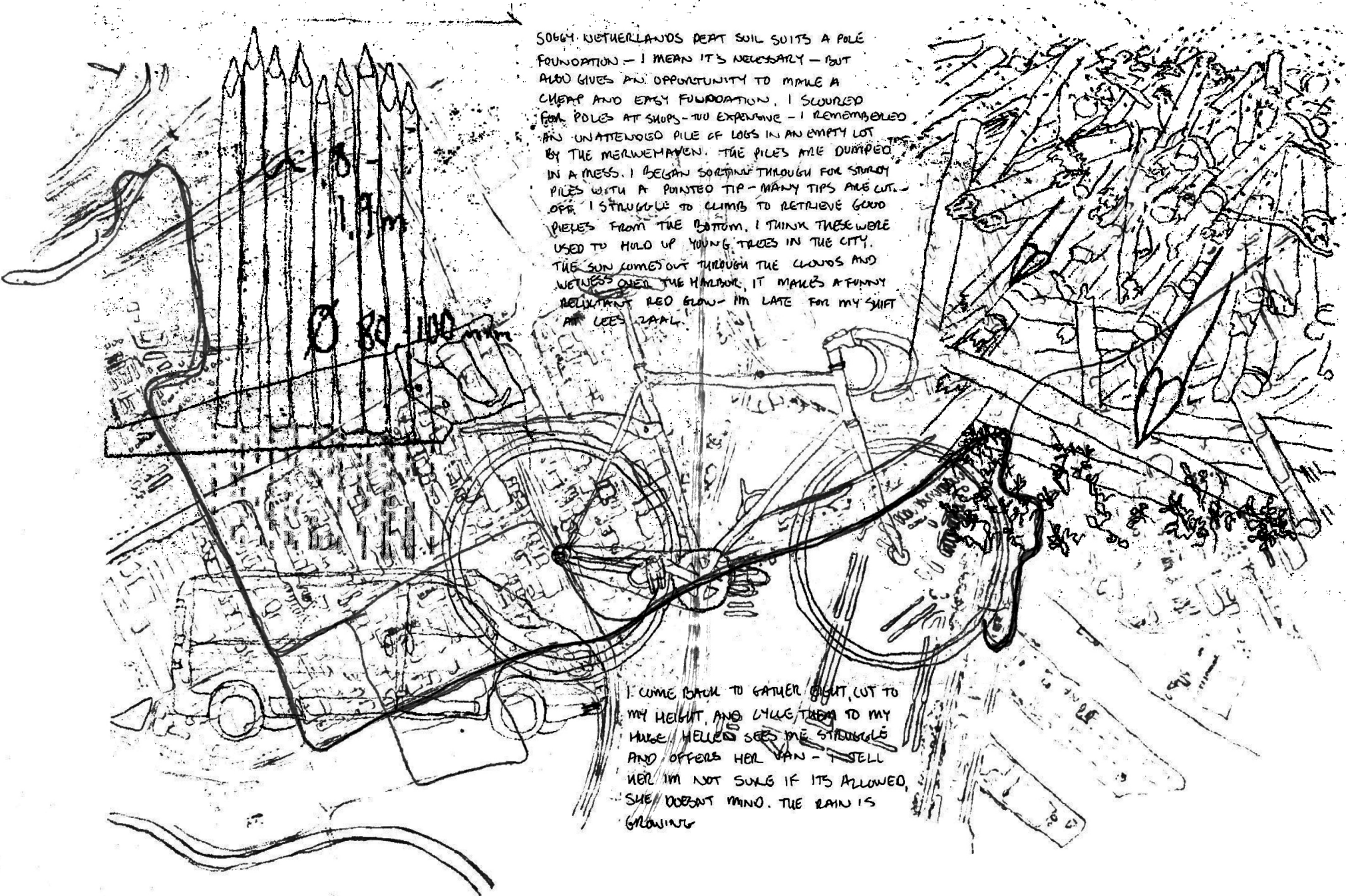

WE MADE ONE L BEAM AND CONNECTED IT ON THE LONG SIDE OF THE POSTS BEFORE THE DRILL SPATTERED AND DIED. THE SCREWS ARE BIG AND THE WOOD THICK AND IMPREGNATED - 12V FESTOOL I GUESS FROM FONS IS NOT INTENDED FOR HEAVY DUTY OUTDOOR WORK. WE HEARD SOME PEOPLE WALKING ON THE PATH. (AT 2AM PITCH DARKNESS), WE WAD SILENTLY IN THE BUSHES WAITING FOR THEM TO PASS - IT REMINDED AARU OF HAMBURGER FOREST, IT EXCITED ME AS WELL, BUT I ENJOYED THE STILLNESS.

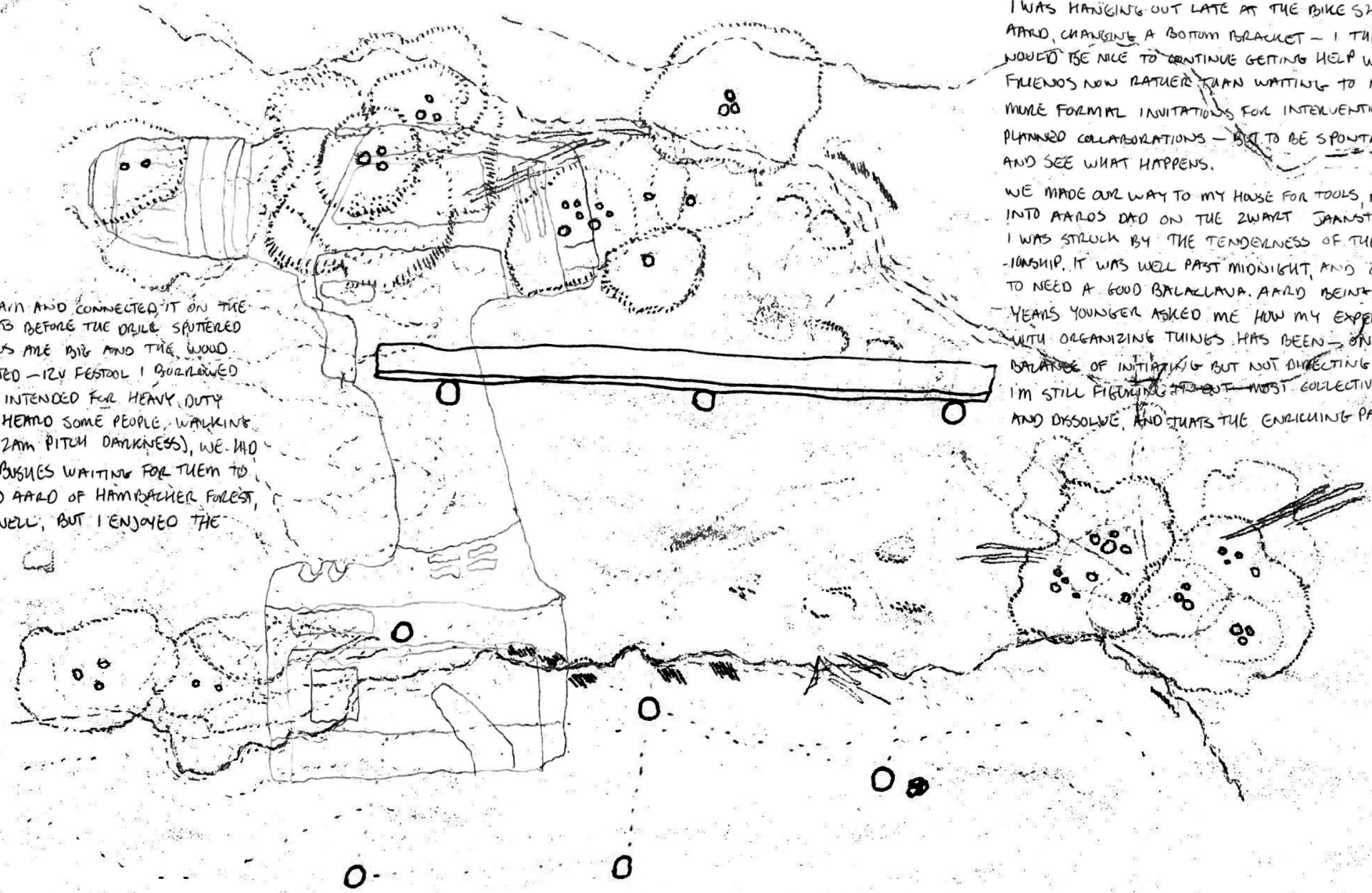

I WAS HANGING OUT LATE AT THE BIKE SHOP WITH AARU, CHANGING A BOTTOM BRACKET - I THOUGHT IT WOULD BE NICE TO CONTINUE GETTING HELP WITH FRIENDS NOW RATHER THAN WAITING TO MAKE MORE FORMAL INVITATIONS FOR INTERVENTIONS AND PLANNED COLLABORATIONS - BUT TO BE SPONTANEOUS AND SEE WHAT HAPPENS.

WE MADE OUR WAY TO MY HOUSE FOR TOOLS, BUMPING INTO AARU'S DAD ON THE ZWART JAANSTRAAT - I WAS STRUCK BY THE TENDERNESS OF THEIR RELATIONSHIP. IT WAS WELL PAST MIDNIGHT, AND COLD ENOUGH TO NEED A GOOD BALACLAVA. AARU BEING EIGHT YEARS YOUNGER ASKED ME HOW MY EXPERIENCES WITH ORGANIZING THINGS HAS BEEN - ON THIS BALANCE OF INITIATING BUT NOT DIRECTING. I SAID I'M STILL FIGURING OUT MOST COLLECTIVES FORM AND DISSOLVE, AND THAT'S THE ENLIGHTENING PART.

I BORROWED AN 18V DRILL FROM PONS FOR THE EVENING, AND VENTURED BACK OUT PAST MIDNIGHT AGAIN WITH SANDRA. THE MOON WASNT VISIBLE WHEN WE ARRIVED. IT WAS THE LOWEST AND DARKEST NIGHT YET - THE FROST ON THE GROUND LAUNCHED AS WE STEPPED. I SWITCHED INTO MY BOOTS, SANDRA WORE THEIR LEATHER HIGHTOPS. THE RED SIGNS FROM THE HIGHWAY REFLECTED ACROSS THE STILL LAKE. WE WORKED DILIGENTLY AND EASILY, ROTATING MAKING CUTS, HOLDING THE BEAMS WHILE THE OTHER SCREWED AND VICE VERSA, GETTING INTO A RHYTHM. THE LAYOUT PRESENTED ITSELF FROM THE ONLY CONNECTION POINTS POSSIBLE. - A SLIGHT EXTENSION SEEMED TO SUGGEST SOMETHING.

THE AIR WAS COMPLETELY STILL - APPROXIMATELY 3am WE TOOK THE CUTOFFS BACK TO THE BUSHES - PAUSED IN SILENCE TAKING NOTE OF THE COLD BREATH AND BLUE HUES - THE STILL LEAVES SILHOUETTED AGAINST THE SKY, A SHARP HALF MOON HAD RISEN DYNAMIOMATICALLY.

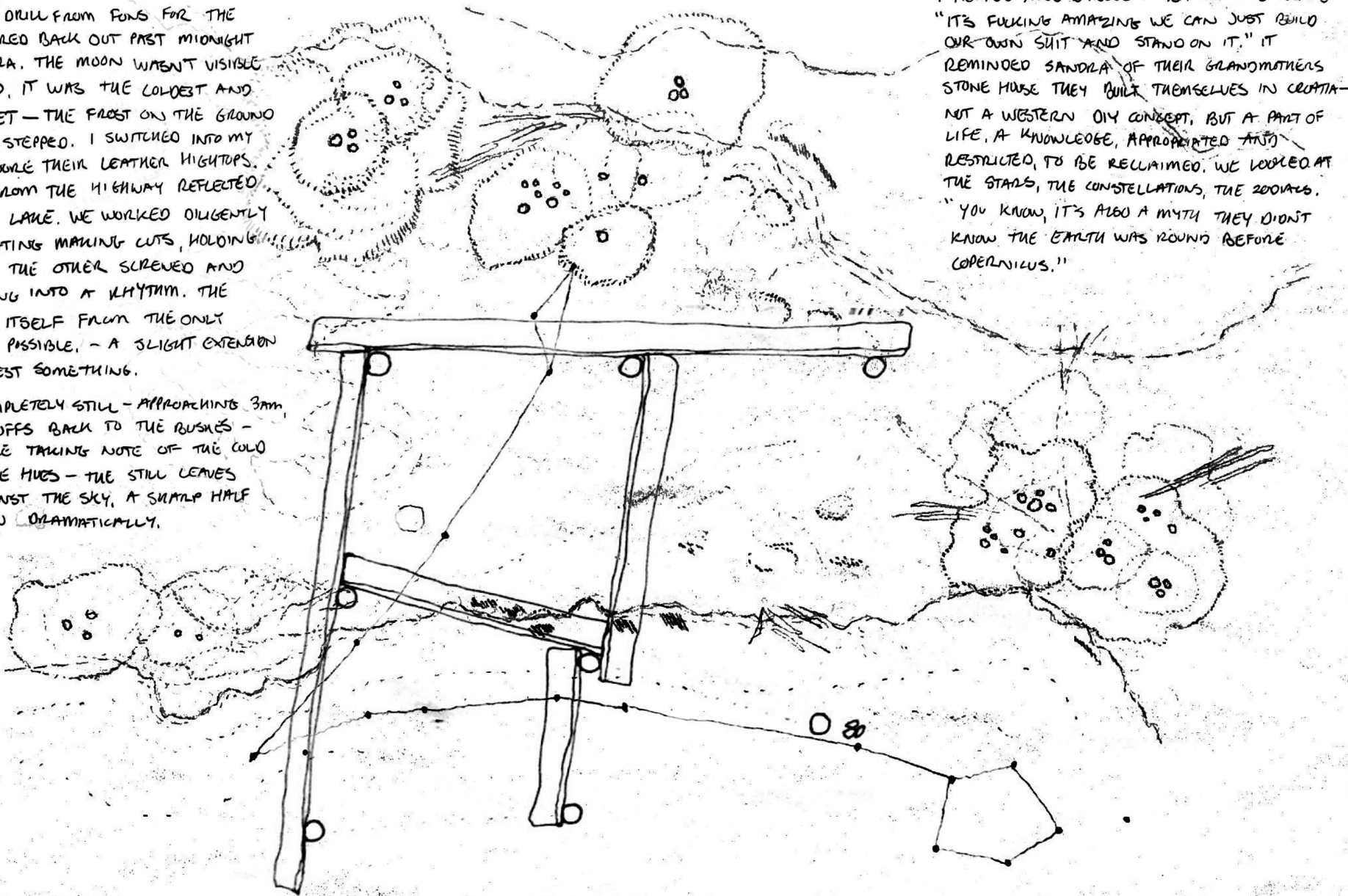

I HOPPED AND DANCED A BIT ON THE BEAMS "IT'S FUKING AMAZING WE CAN JUST BUILD OUR OWN SUIT AND STAND ON IT." IT REMINDED SANDRA OF THEIR GRANDMOTHERS STONE HOUSE THEY BUILT THEMSELVES IN CROATIA - NOT A WESTERN DIY CONCEPT, BUT A PART OF LIFE, A KNOWLEDGE, APPROPRIATED AND RESTRICTED, TO BE RECLAIMED. WE LOOKED AT THE STARS, THE CONSTELLATIONS, THE ZODIACS. "YOU KNOW, IT'S ALSO A MYTH THEY DIDNT KNOW THE EARTH WAS ROUND BEFORE COPERNICUS."

THE MUD WAS GROWING FROM OUR CONTINUAL
WORKING ON OUR KNEES - WE HAD TO TAKE
EXTRA CARE TO BRING PROVED PANTS TO KEEP
WARM AS WE GOT WET AND MUDDY.

WE WERE ENJOYING THE MUD ALL THE MUCH
MORE ACTUALLY. STRANGELY WE HEARD AND
SMELLED A CAMPFIRE, SPURRING US ON. WE
WENT TO TALK TO THEM BUT ONLY FOUND
EMBERS - SPEAKING INTO THE TREES THAT
WE WERE FRIENDS, WE GOT NO RESPONSE. TWO
HOURS LATER WE SMELLED THE FIRE AGAIN -
STRANGE... I WONDER IF THEY STOLE OUR WOOD.

WE MADE A LOT OF EFFORT TO ATTEMPT TO
LEVEL THE GROUND SOMEWHAT AS WE NOTICED
THE LEFT SIDE WAS SUBSTANTIALLY LOWER THAN
THE RIGHT, VISIBLE ONCE YOU LIE A BEAM
THERE. NOT SURE IF ITS SUCH AN ISSUE - WE
CAN LEVEL THE FIRST PLATFORM RATHER THAN
THE FOUNDATION - BUT WE MADE AN EFFORT TO
DISTRIBUTE THE LOAD SO THAT THE BEAMS
WOULDN'T HINDER. WE TOOK THE CLAY LUMPS
FROM THE POST HOLES AND PACKED THEM
UNDER THE FOUNDATION, USING CUT OFFS
FOR THE VERY LARGE GAPS, WE SMACKED
THE MUD FLAT WITH THE BEAMS, MAKING
A SQUISHY SOUND.

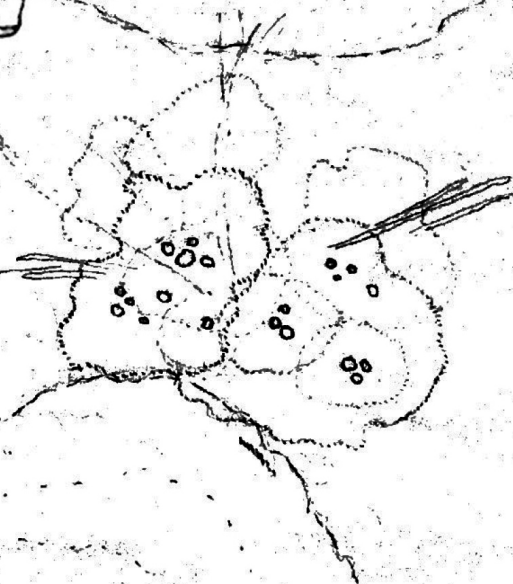
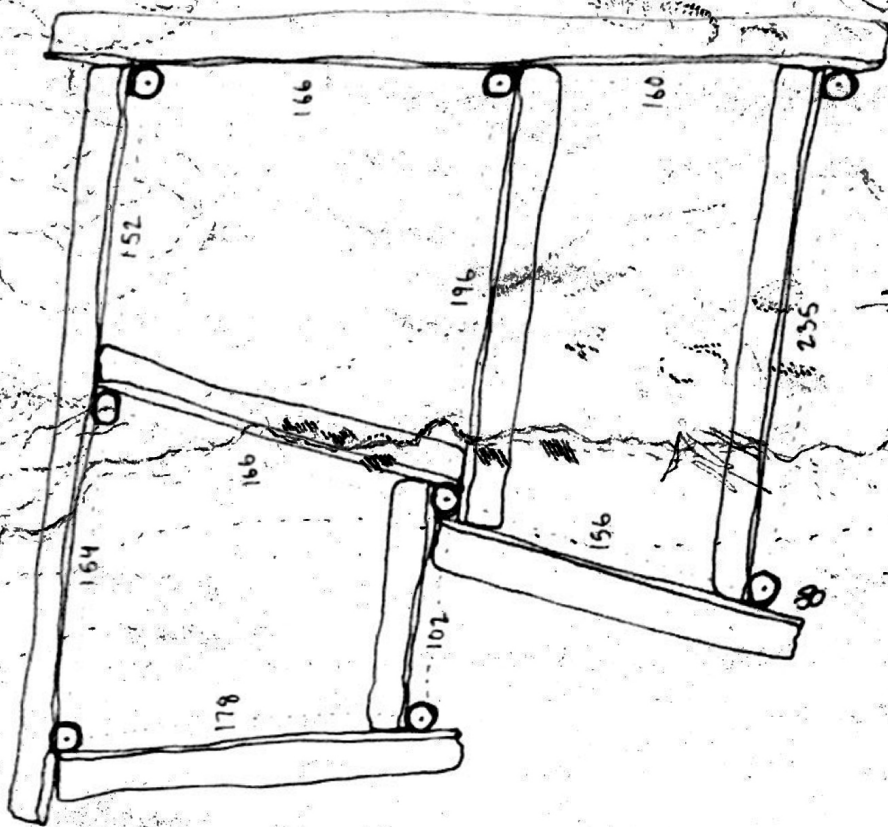

WHEN WE FIRST ARRIVED, WE HAD TO FIGURE OUT THE BEST WAY TO ACCOUNT FOR THE DIFFERENCE IN THICKNESS BETWEEN THE FOUNDATION BEAM AND THE STRUCTURAL BEAM - IF WE WERE TO STICK TO THE METHOD OF SANDWICHING BEAMS BETWEEN TWO POSTS, ANGELOKI SUGGESTED THAT A FLEX PINCHING IN AT THE TOP WOULD BE BETTER THEN A PINCHING IN AT THE BOTTOM. MICHELE AGREED, AND THE REST OF US THOUGHT IT MADE SENSE SO THAT'S WHAT WE DID.

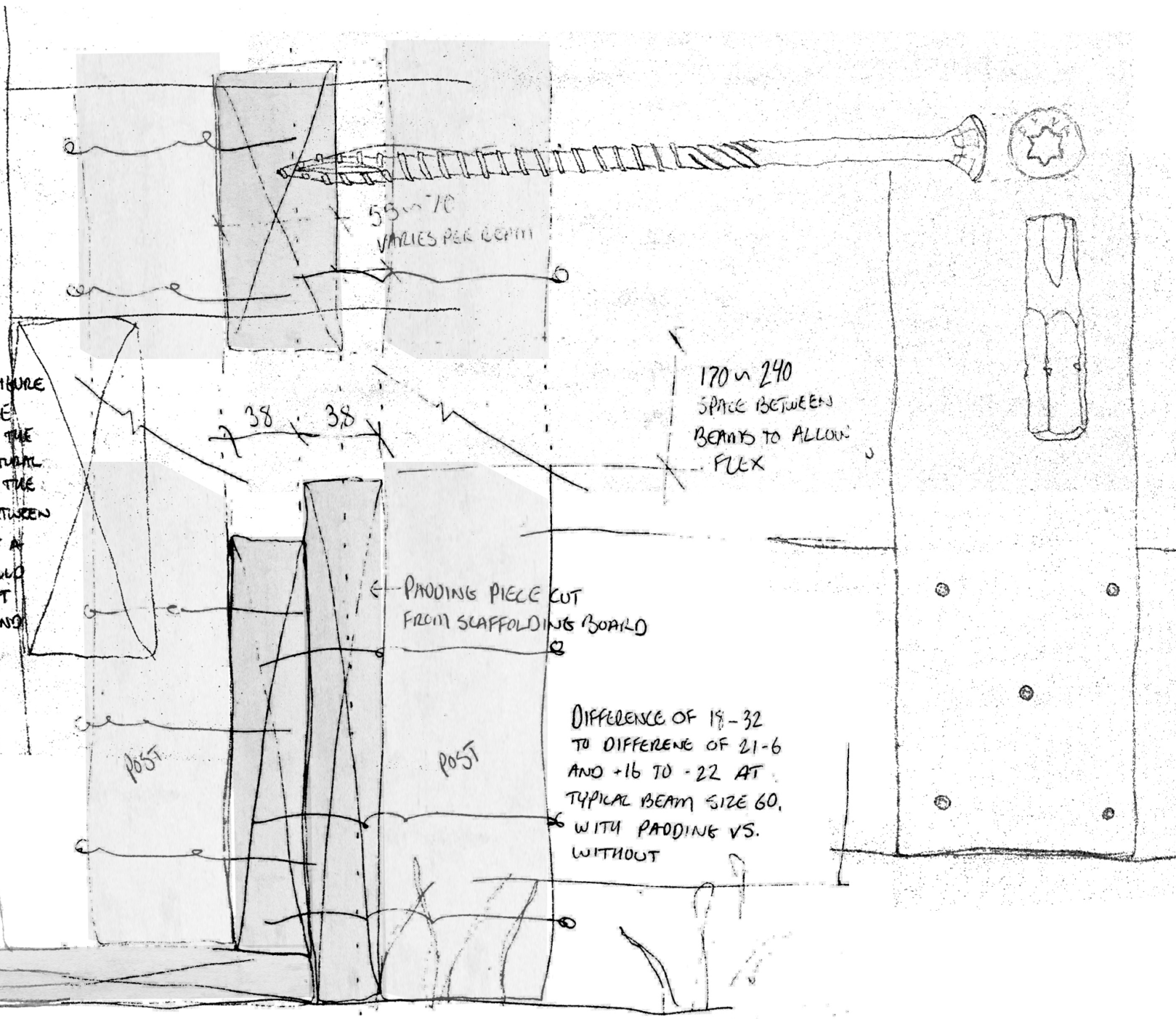

55-70
VARIES PER DEPTH

38 38

170-240
SPACE BETWEEN
BEAMS TO ALLOW
FLEX

← PADDING PIECE CUT
FROM SCAFFOLDING BOARD

DIFFERENCE OF 19-32
TO DIFFERENCE OF 21-6
AND +16 TO -22 AT
TYPICAL BEAM SIZE 60,
WITH PADDING VS.
WITHOUT

POST

POST

IT'S GETTING DARK NOW. THE PLANES FLY

DIRECTLY OVERHEAD. THE RUNWAY IS IMMEDIATELY
ON THE OTHER SIDE OF THE REEDS. WE TAKE ABOUT SOME
65 MILLIMETRAL RESINITE TO THE ANTAROPOLICENS. WE
LAY OUT THE POSTS BY THE SIMPLE 20cm SQUARES I
HAD THOUGHT BEFORE. "DON'T YOU WANT TO CHECK IF
THE ANGLES ARE 90°? YOU'LL HAVE TO MAKE SO MANY
CUTS OTHERWISE." "NO I DON'T MIND. I MIGHT
ACTUALLY LIKE IT. PREFER IT EVEN."

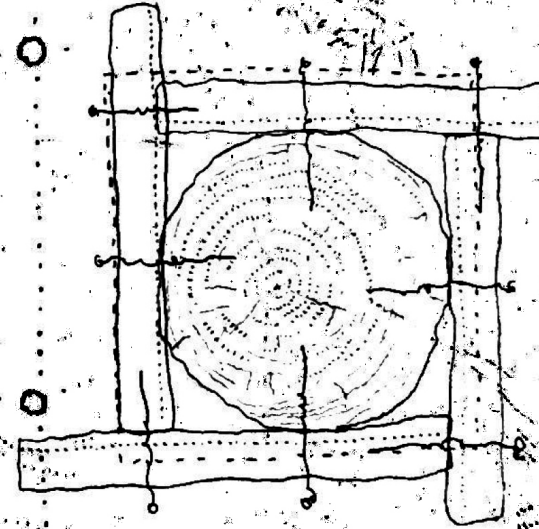
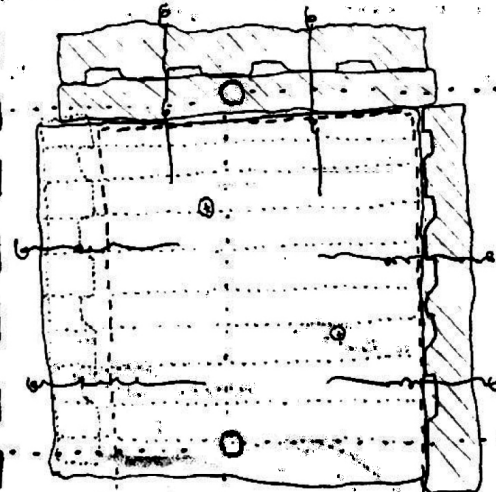
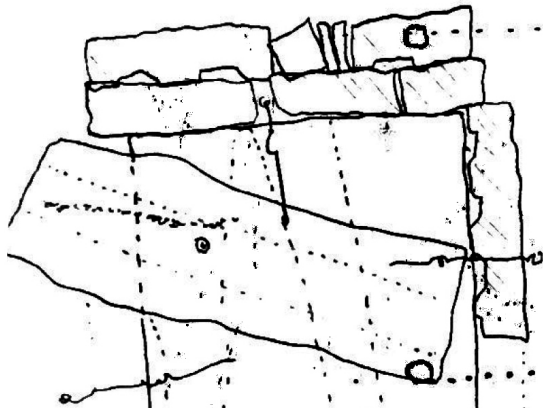

WE STRUGGLE TO POUND POSTS FURTHER THAN
50cm BEFORE THEY BEGIN TO SPLIT. I GO TO A
DUMPER NEARBY TO FIND SCRAP WOOD TO MAKE
A CAP WE CAN HIT TO ABSORB BLOWS OF THE
HAMMER. THE DRIVING WOOD IS TOO BRITTLE AND
SNAPS AT THE SCREWS AFTER A FEW HITS.
OUR HANDS ARE COLD IT GETS DARKER. WE
CAN HARDLY SEE A THING - A DESOLATE
DARK WINTER, IN A DESOLATE PARK ON THE
EDGE OF THE CITY. BY THE MOUNTAIN AND CANYON

POLDER FIELDS EXTRACTED FROM PEAT IN SHELLEWIC

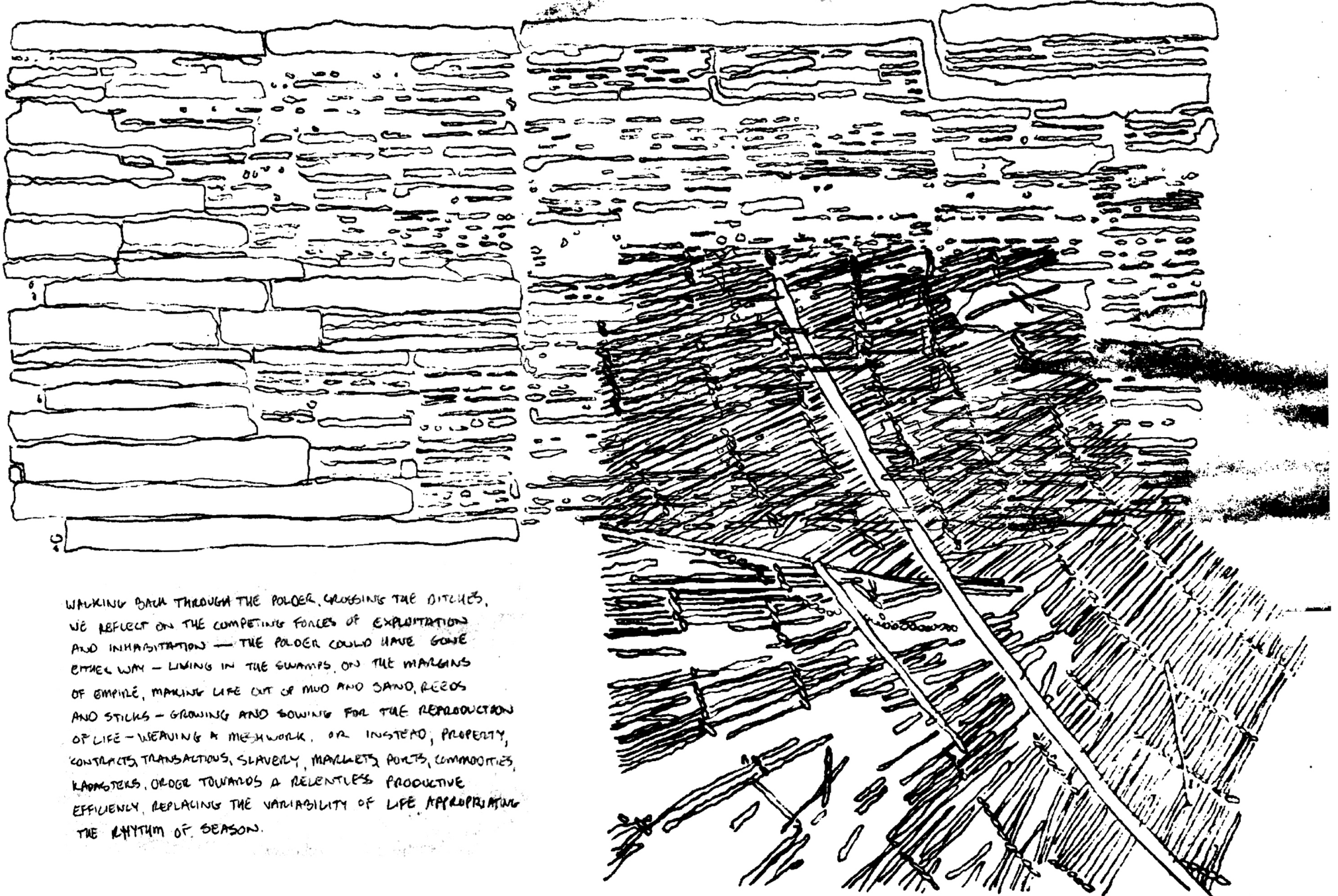

WALKING BACK THROUGH THE POLDER, CROSSING THE DITCHES,
WE REFLECT ON THE COMPETING FORCES OF EXPLOITATION
AND INHABITATION — THE POLDER COULD HAVE GONE
OTHER WAY — LIVING IN THE SWAMPS, ON THE MARGINS
OF EMPIRE, MAKING LIFE OUT OF MUD AND SAND, REEDS
AND STICKS — GROWING AND SOWING FOR THE REPRODUCTION
OF LIFE — WEAVING A MESHWORK, OR INSTEAD, PROPERTY,
CONTRACTS, TRANSACTIONS, SLAVERY, MARKETS, PORTS, COMMODITIES,
KAMPSTERS, ORDER TOWARDS A RELENTLESS PRODUCTIVE
EFFICIENCY, REPLACING THE VARIABILITY OF LIFE APPROPRIATING
THE RHYTHM OF SEASON.

A NEOLITHIC FISHING NET FOUND IN BELLSCHENHOEK

I BEGAN MOVING THE POTS
FROM MY HOUSE TO THE SITE,
ONE BY ONE ON MY BIKE.
IT TAKES 8 TRIPS BACK
AND FORTH, 10 MINUTES
EACH. THE DAY IS ENDING.

THE REPETITION AND THE PROMISE
LOW WINTER SUN ZONE ME OUT
AND WARMS MY FACE, BLOWN BACK
AND GOLDEN SHADOWS. I REMINISCE
ON THE NIGHT BEFORE, THE QUEER
ENCOUNTERS, AND MISSED ENCOUNTERS,

AND HOPEFUL TO STILL BE ENCOUNTERS.
I KNOW EVERY BUMP IN THE ROAD,
MEMORIZING THE PATH OF MY BIKE,
THE MISSING BRICK BY THE HIGH-
WAY ENTRANCE, AND THE S-SHAPED
GULCH BY THE END OF MY STREET

SANDRA ASKED ME IF
I DO GET SCARED OF
MAKING EYE-CONTACT ON
THE DANCE FLOOR. I SAID
YES, I WISH IT WAS
EASIER.

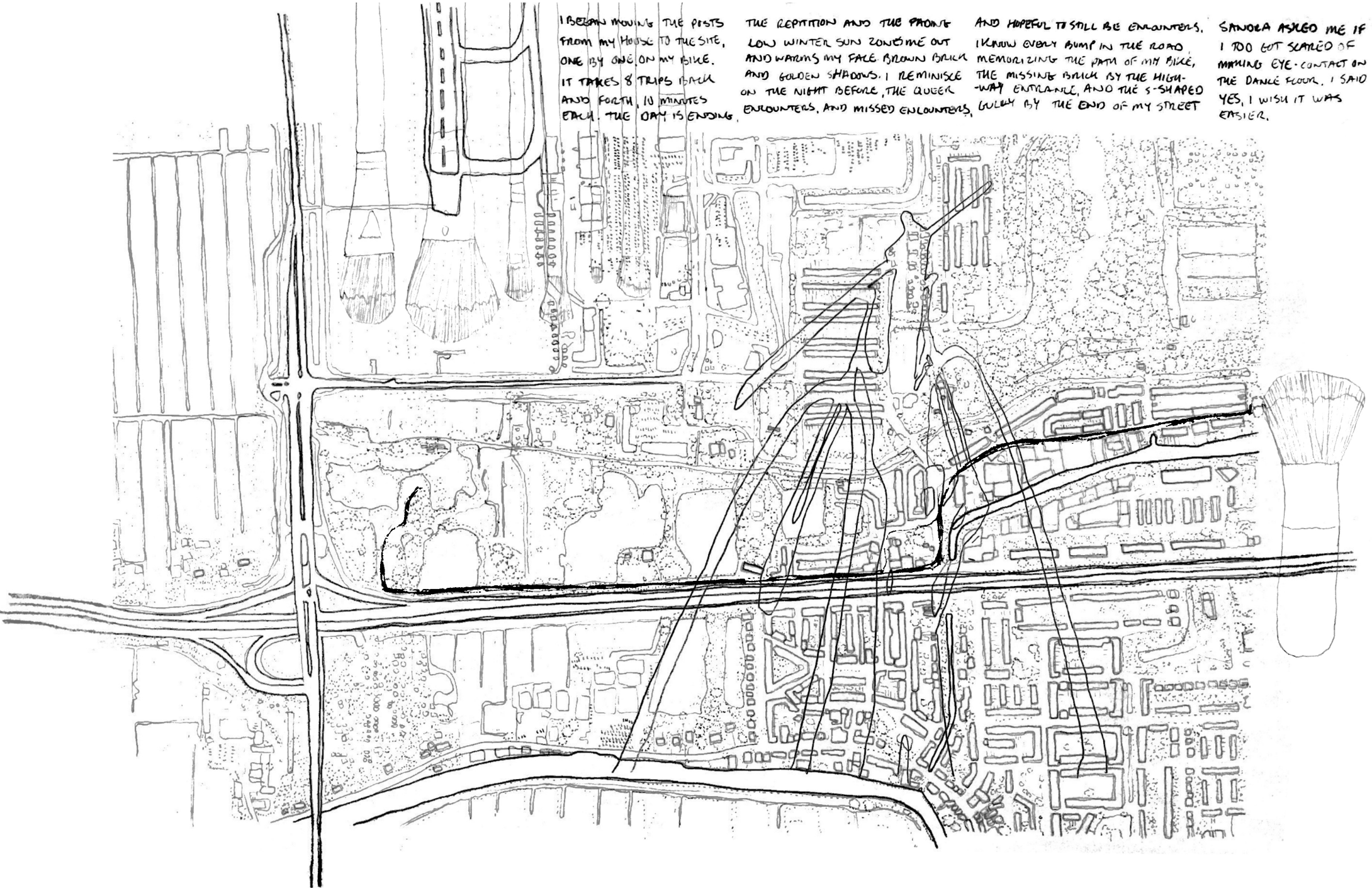

IN THE SHORT GRASS I FELT EXHAUSTED -
 I SPENT SOME FAINT DAYS THERE ATTEMPTING
 TO PUT THE PANTS IN TO NO AVAIL, SURPRISED
 AT THE AMOUNT OF JOB WALKERS WHO FELT
 IT EASY TO COME QUESTION ME - IT'S NOT
 SO VISIBLE, CAN EASY AND INVITING TO ACCESS -
 A TOWER STANDS OUT STRANGELY THERE...

IN A WHILE I DECIDED TO MOVE THE
 TOWER, I'D TAKE THE BEAMS TO THE
 TALL GRASS. I TOOK TWO ON MY
 BACK BEFORE I ENCOUNTERED WHAT
 LOOKED LIKE A MUNICIPAL WORKER,
 WHO LOOKED AT ME WITH PICKING
 EYES. SPOOKED, I GOT ON MY BIKE
 AND LEFT, LEAVING THE REST OF THE
 BEAMS BY THE SIDE OF THE ROAD.

I RETURNED LATE AT NIGHT, AFTER
 MY WORK SHIFT, TO FIND 2 OF THE
 BEAMS MISSING. DISTRAUGHT, I CARRIED
 THE REMAINING TO A BEAMS THICKET
 HIDDEN FROM VIEW OF THE PARK
 I'M NOT ALONE HERE. MY SHADOW STUMBLES
 ME.

WITH MICHELE WE TWIST AND
 PIVOT THE PARTIALLY INSERTED
 POSTS LOOSE FROM THE LAY,
 WITH A POPPING SUCTION. GALAXY
 THEM IN THE DARK TO THE TALL
 GRASS, ONE AT A TIME, MAKING
 EIGHT TRIPS INSTEAD OF FOUR.

I TOLD THE LUMBERYARD TO MAKE THE DELIVERY
 ALONG THE FRONTAGE ROAD OF THE HIGHWAY, JUST
 BEFORE THE BEND IN THE ROAD, AND I'D BE THERE
 WAITING. THEY DIDN'T ASK TOO MANY QUESTIONS I TOLD
 THEM IT WAS A STUDENT ART PROJECT IN THE PARK.

AS I WAITED, WHICH WAS A LONG WAIT, I STUMBLED
 BACK AGAIN THROUGH THE PARK - NOVEMBER HAD
 TURNED THE GRASS GOLDEN BROWN, THE LEAVES
 HAD LEFT THE TREES BARE, AND THE WATER SILKY
 GRAY - I WANDERED TO A SECLUDED SPOT NESTLED
 BY THORN BUSHES, TREES, THE LAKE, A POND AND A
 FALLEN TREE - IT WAS UNUSUAL TO EVERYWHERE, BUT
 SOMEHOW FELT SAFE, AMONG THE TALL GRASS AND
 BEAUTIFUL...

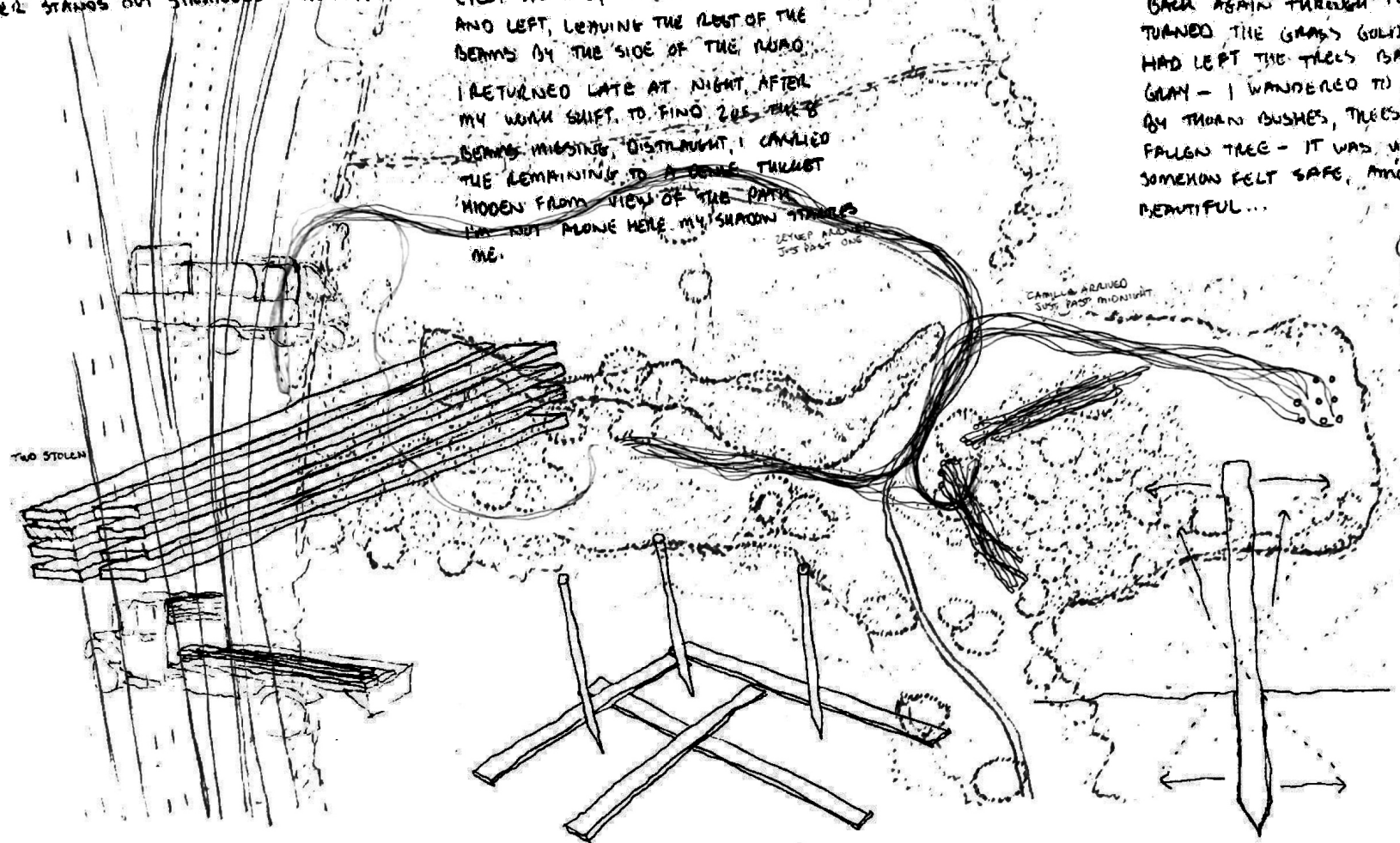

TWO STOLEN

I'M NOT ALONE HERE. MY SHADOW STUMBLES ME.

CAROL ARRIVED SOME PAST MIDNIGHT

WE LAID OUT THE BEAMS AS A REFERENCE POINT FOR LINES

EAGER TO BEGIN, UNLESS OF COLLECTIVE ORIGINS, —
 POSTS AND BEAMS ON THE GROUND, A FOUNDATIONS,
 SEEMED LIKE AN EXCITING INITIATIVE TO INVITE
 FRIENDS TO DANCE AND WALK ON. SHARING
 THE IDEA WITH ALVARO, PASSING BY IN WORK,
 SUGGESTED A PLATE TO PREVENT THE POSTS FROM
 SINKING.

A FAIRLY EVENING I CHATTED WITH PONS IN THE
 SHED CHANGING THE DRILL BATTERIES. HE WITTED ON
 A HANDLE, THE IDEA OF AN L HE APPROVED, BUT
 SUGGESTED AN ANGLE IN THE POSTS TO COUNTERACT
 THE WIND — I WAS SKEPTICAL IF IT WAS NECESSARY,
 SO WAS ALVARO — THE UPWARD FORCES DIDN'T
 SEEM STRONG ENOUGH

I SENT SOME IDEAS OF AN L TO ALVARO, **B** WORKED
 BETTER — ACTS AS A FOOT TO PREVENT SINKING, DISPERSE
 THE LOAD DIRECTLY TO THE EARTH, AND ACT AS A
 MOMENT CONNECTION TO PREVENT ROTATION. KEY TO
 GET THE TWO BEAMS TO ACT AS ONE, THESE SHOULD
 BE IMPLANTED IN PRESSURE TREATED TO PREVENT
 ROT SINCE THEY WILL BE ON THE GROUND, SO WE
 SHOULD BUY NOT SLAVEAGE TO SAVE TIME AND TO
 BE SURE, AND CONSISTENT — TO GET STRATFED

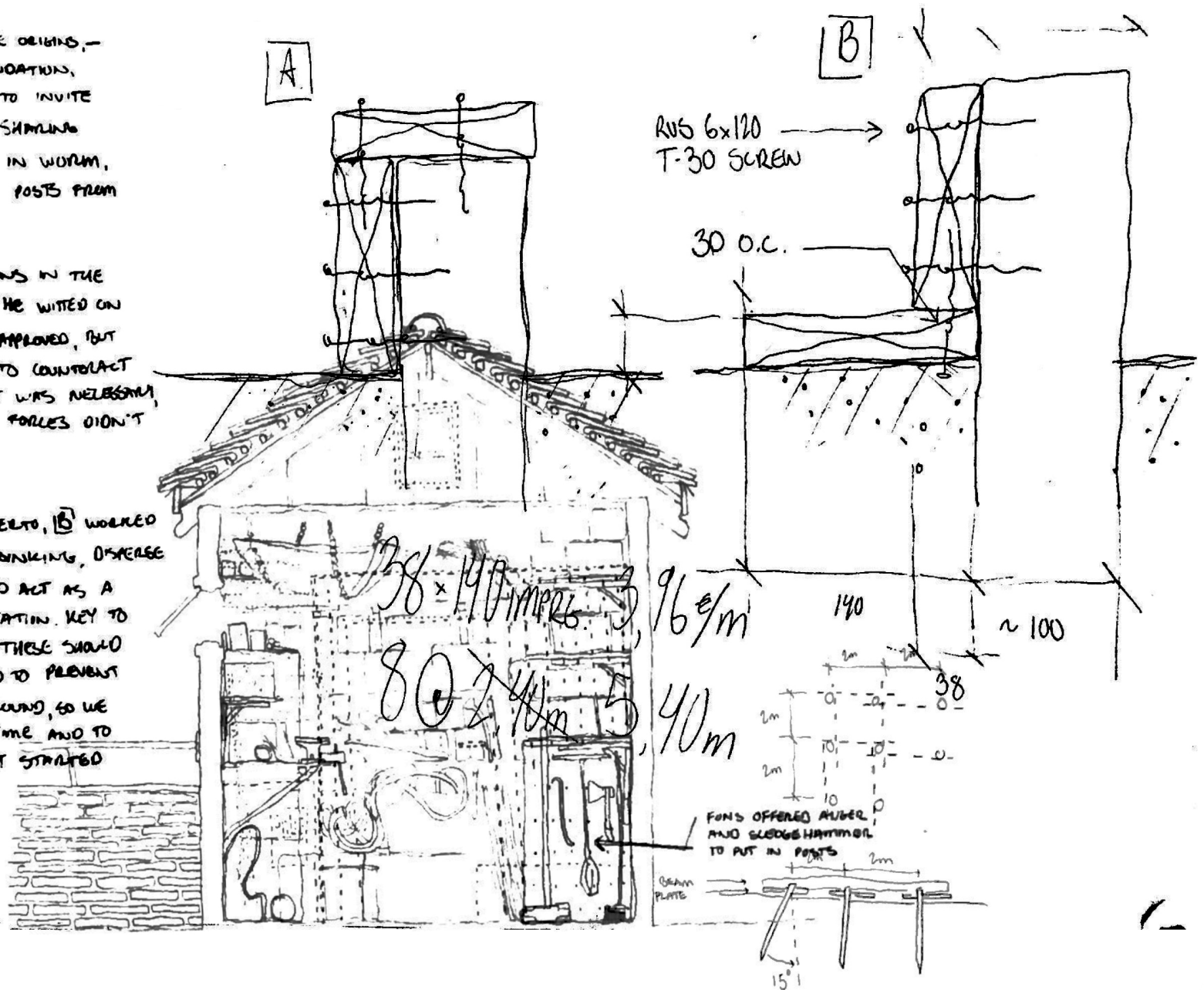

I SPoke WITH MAAMI ABOUT THE TOWER
ONE LATE NIGHT AT THE BAR AT PONTAGE-
MAJUN AFTER THE CLOTHES SWAP. THE LIVING
COMMUNITY BY THE MARS, STARTED AS A
SWAP. WE TALKED ABOUT HER GRAD PROJ-
ECT, THE CHALLENGES IN BUILDING COLLECTIVES,
THEIR ATTEMPTS AT A PIRATE RADIO, AND
SHARING PRIVATE SPACES. RETURN WITH FINE
RULES WITHOUT HIERARCHY - BOUNDARIES WITH
OPEN FORM & HOW TO DEAL WITH SOMEONE WHO
TAKES TOO MANY CLOTHES.

MULRE AND CAMILO HELPED CURS SET UP THE
GETCAFE, COMMUNALLY COOKING IN A MANNER
OF PICKING UP WHERE THE LAST PERSON LEFT
OFF, LEAVING OPEN FORMS THAT WERE
GRASPABLE; MARLI, GURLOON AND I ESCAPED
THE RAIN FOR A LONG CHAT ON REPRODUCTIVE
CARE WORK, STRETCHING OUT OVER THE PAB
TABLE. ZEYNER AND DOMINIK JOINED US
FOR SEWING THE FABRIC WALLS, SHOWING
SHEVER HOW TO MAKE A KNOT. MANY
WALKS ALONG THE HARBOUR, PARTIES, BARS,
ENCOUNTERS. LADDERS STORED IN THE
BASEMENT.

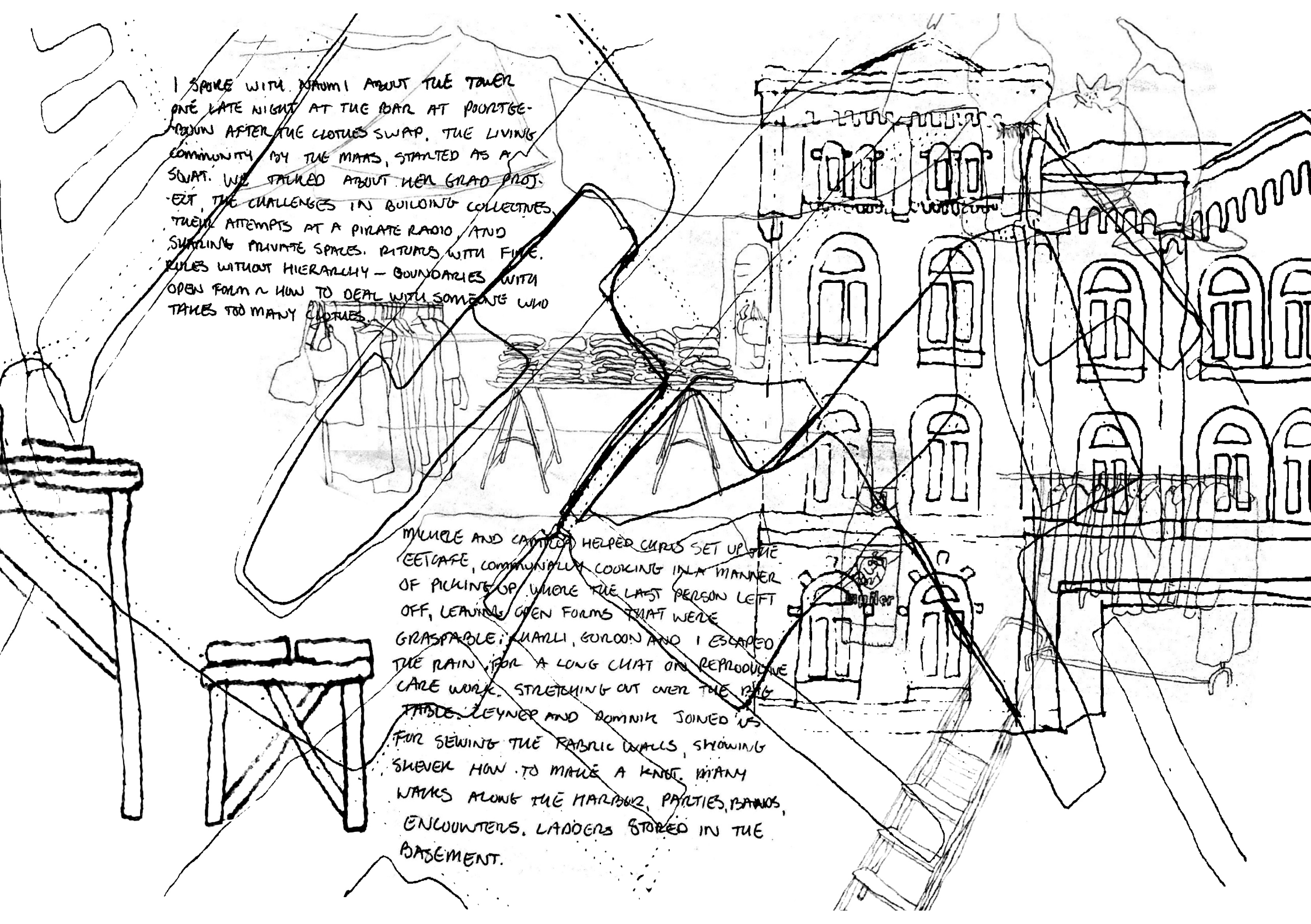

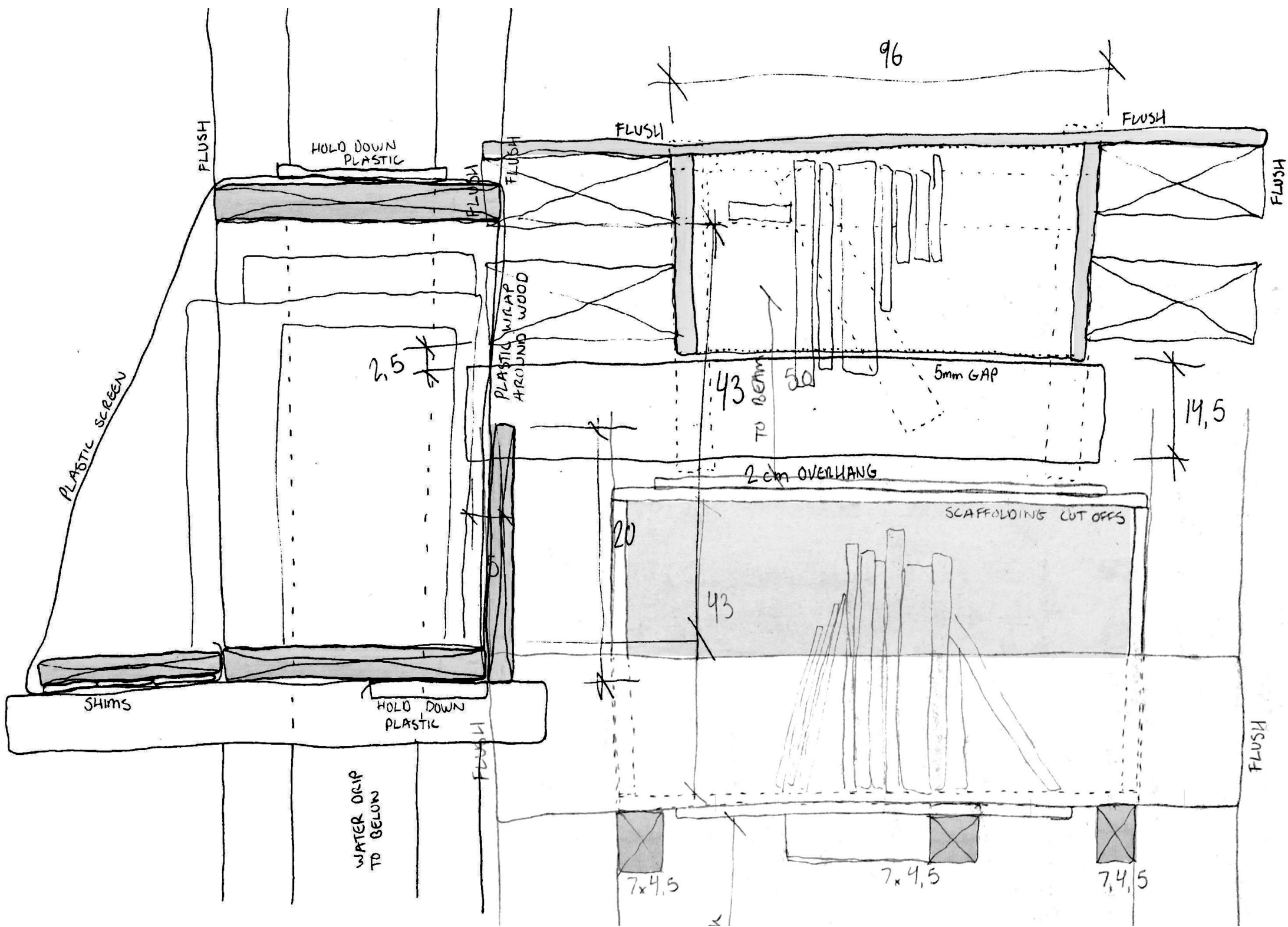

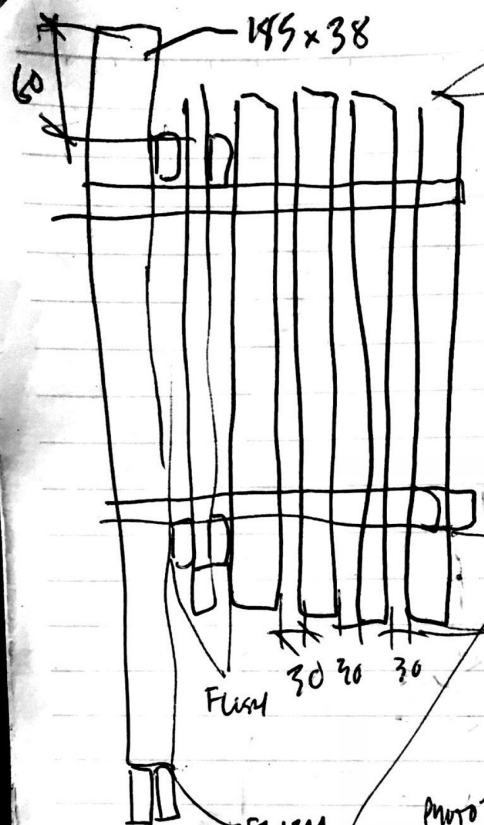

130x35
STAVROS LEBKON FEB11
 (MANAGING PLAN, ENV. +
 WOOD. → AFFECT OTHERS
 MAJOR
 → ENCYCLOPEDIA
 120 MINOR/MAJOR
 SIMONDOONUM
 (TIME TRAVEL)

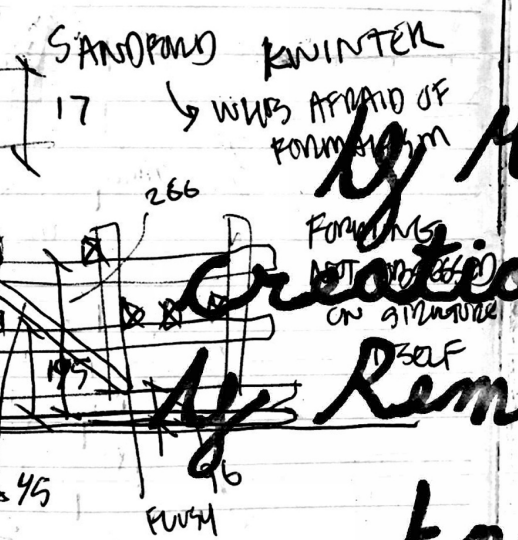

Memory is
 Creation
 Remembering is
 knowledge.

TRANSAPPERTIVE
 (STAVROS)
 BASIC APPERTIVE
 REPEROME
 THAT IT
 SELF WAS SPACING
 AN APPERTIVE 2cm ARE
 APPERTIVE 1.5 → 2.5 mm
 DESIGN IS TO
 AFFECT WORLD (LUMB)
 INFORMATION (ASSEMBLY)

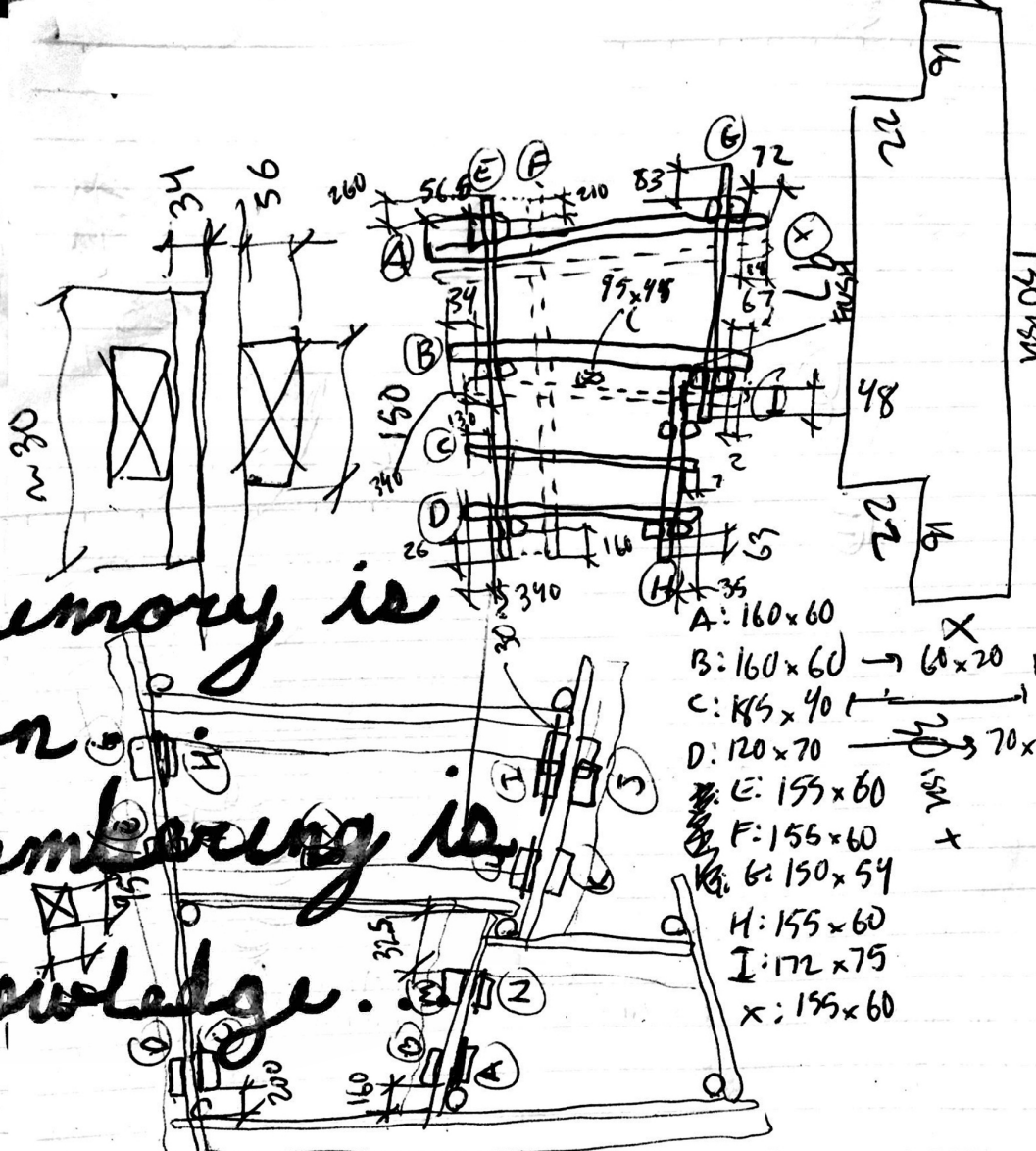
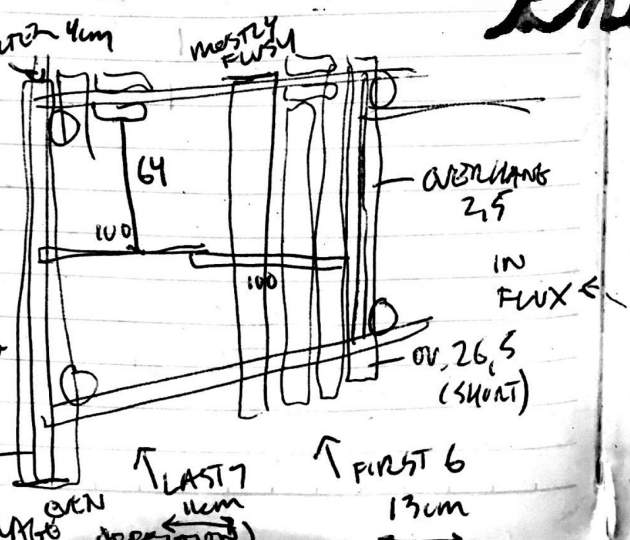

- A - 349
- B - 333 (-SHORT)
- C - 360 (-SHORT)
- D - 360
- E - 0+4
- F - 360
- G - 360
- H - 360
- I - 360
- J - 360 (-SHORT)
- K - PARTY - CANDLES
- L - BATTERY LIGHTS
- M - CANDLES + BATTERY
- N - A
- Z

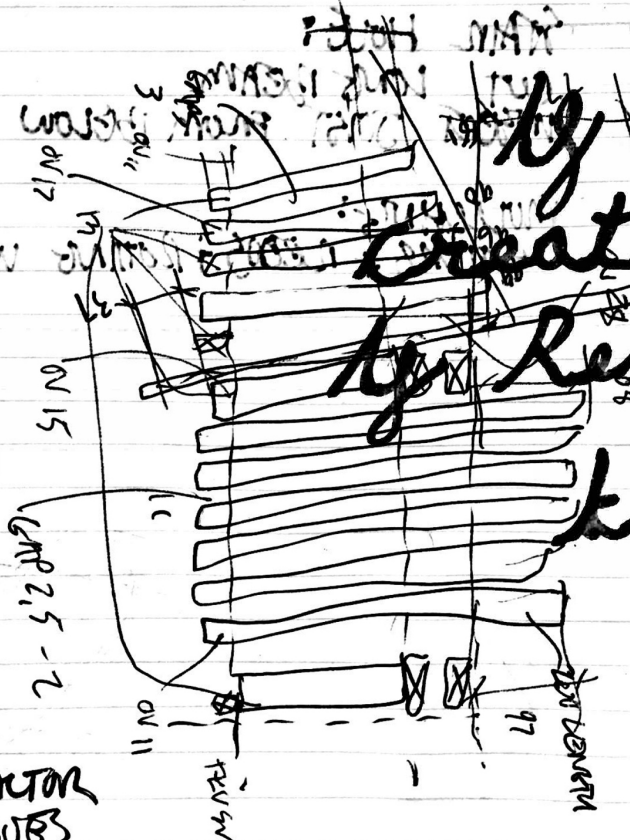
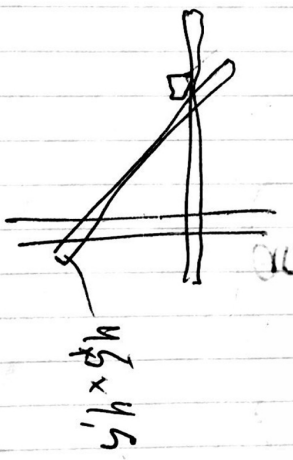
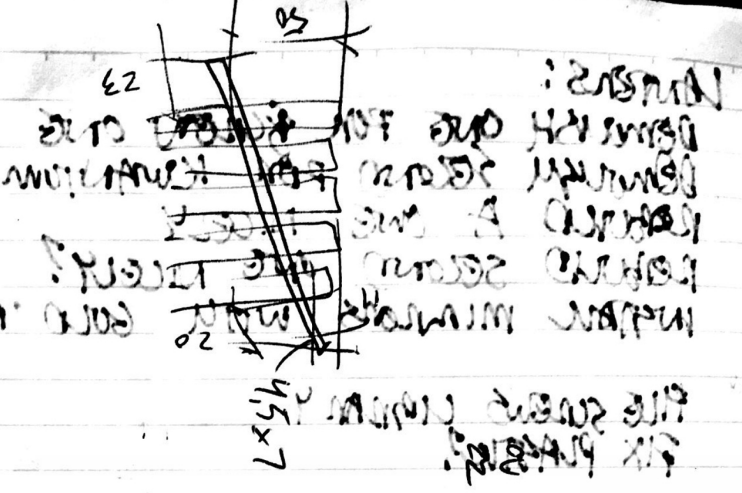
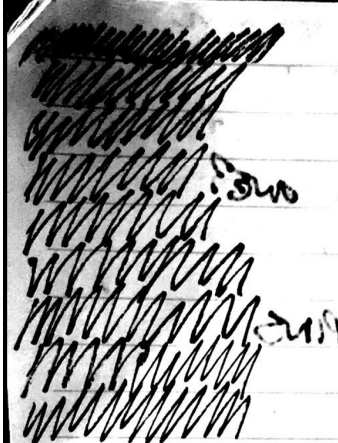

My Memory is Creation...

My Remembering is Knowledge...

ATTITUDE NOT METHOD
 GOING ABOUT DESIGNING
 ATTRACTOR TO ATTRACTOR
 RESPONDING TO ISSUES
 REAL LIFE
 JOHN DENNEY

META
 AFFECTIVE W/MP
 ALL OF THESE THINGS
 ARE CO-DESIGNING WITH

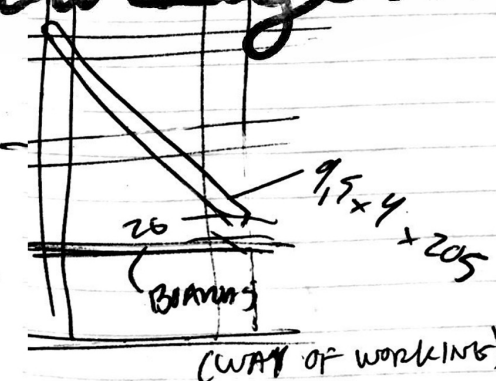
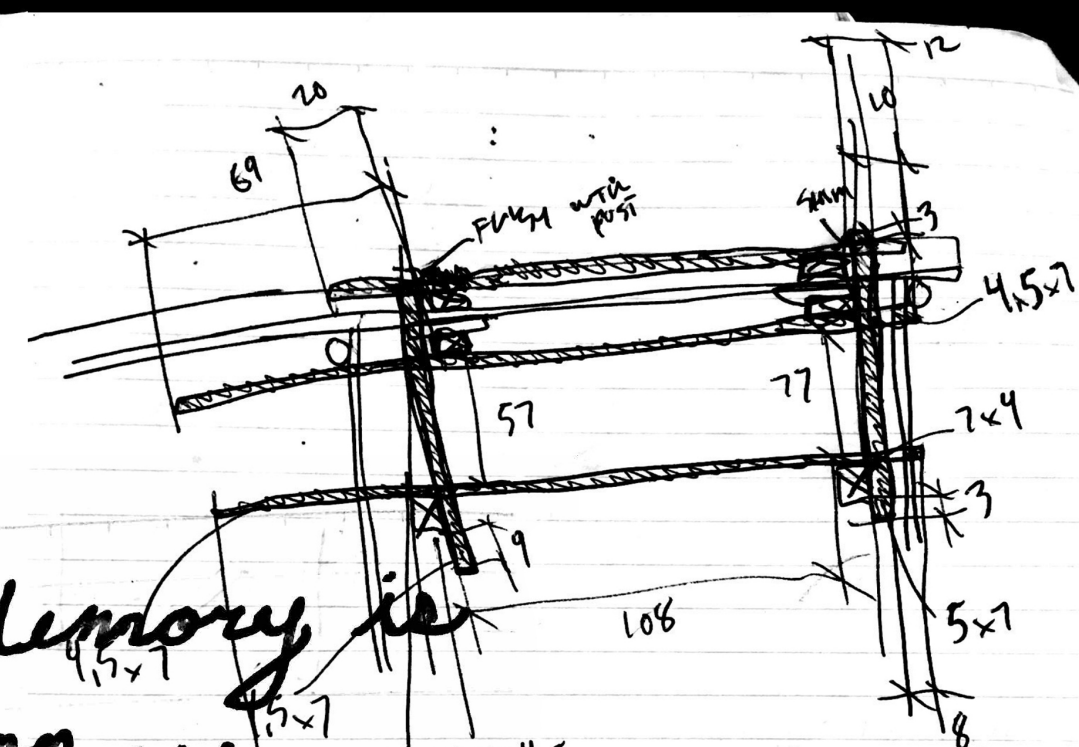

- STRATEGICAL
 ↑ TECHNICAL
 - AESTHETICS (RESULT OF WHAT THEY DO)
 - DESIGNER
 - MAP (AFFECTIVE)
 - PROCESS: DESIGN THROUGH MAKING

(WAY OF WORKING)
 - VALUES (DESIGNS WITH)
 LOVE, CARE, RELATIONSHIP,
 RESOURCES, ACCESSIBILITY,
 AFFORDANCE

- DRAWING IS EVALUATIVE
 (DOCUMENTATION NOT PROJECTIVE)

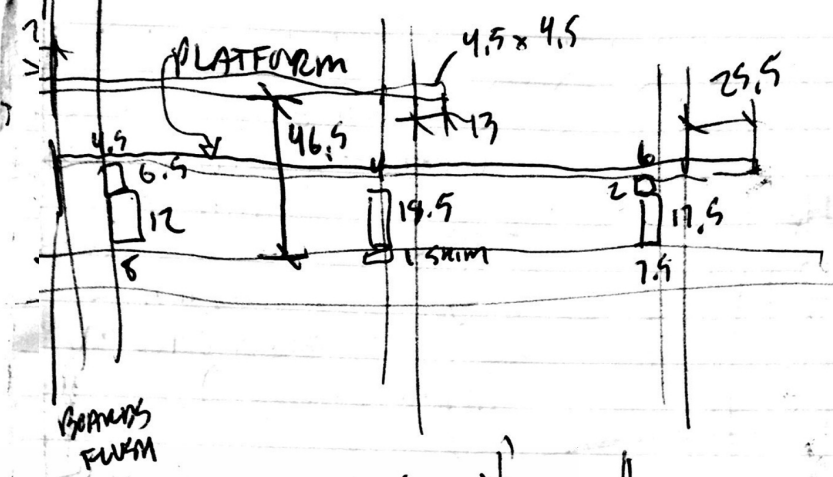
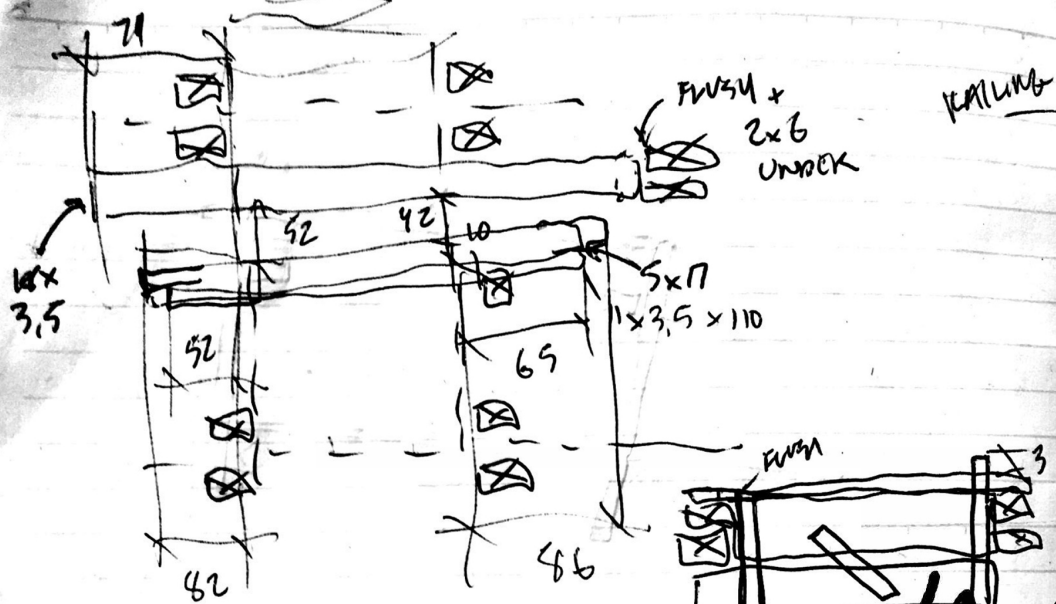

BEAMS STONE:
 A: 7x21 x 300
 B: 7x22 + 4 ON TOP x 290
 C: 6x15,9 x 265
 CROSS BRACS: 390 x 45 x 90

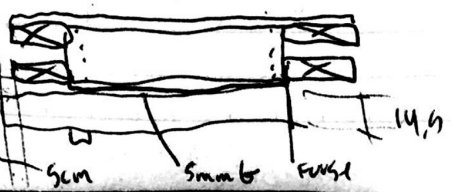
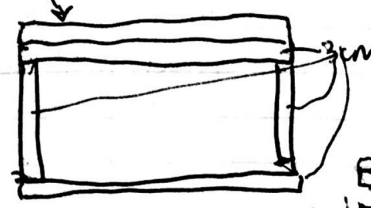
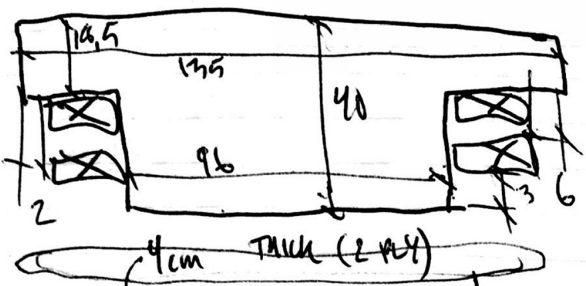

Memory is
 creation...
 by remembering
 knowledge.

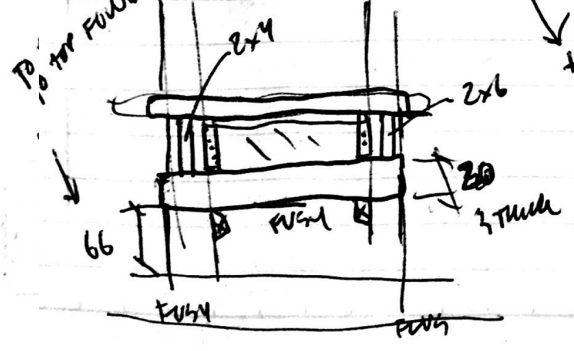
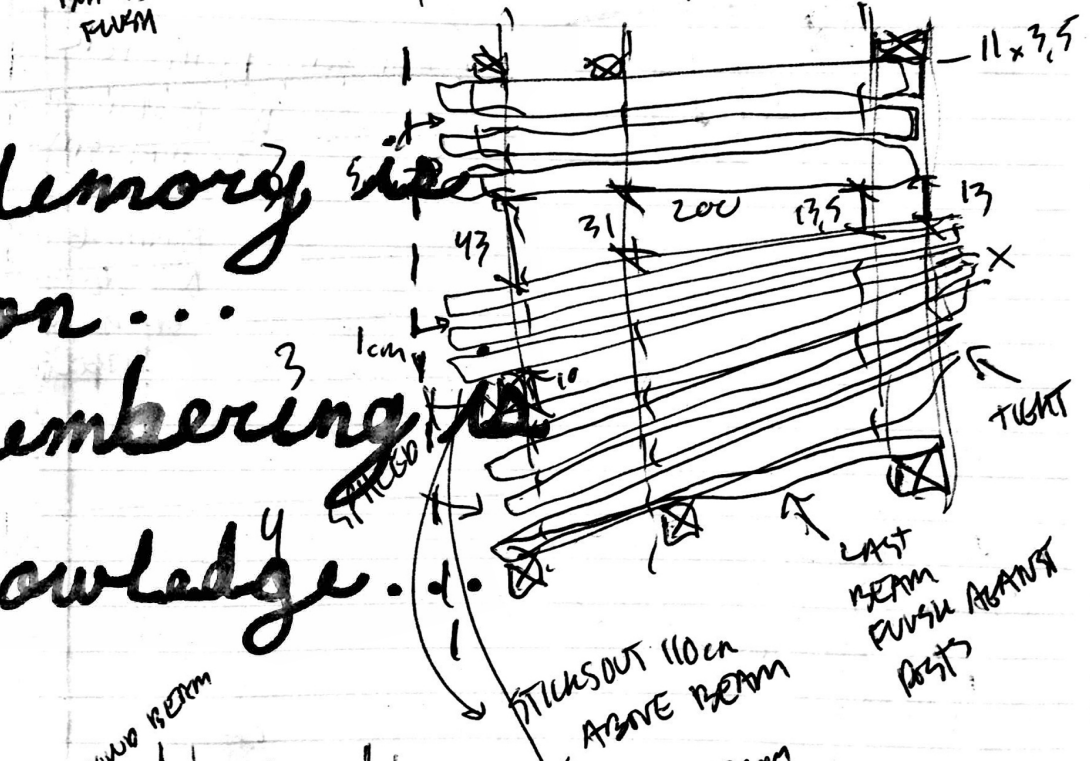

SOPHIA JOINED ME AND OLIE AND SANDRA TO FIGURE OUT HOW TO MAKE A CLEANER AND EASIER FIRST STEP TO GO UP. WE CONSIDERED GOING THROUGH THE GAP IN THE PLATFORM, AROUND THE OUTSIDE, AND UP THROUGH THE TALL PART - WHICH SEEMED LIKE AN ENTRANCE, WHERE WE HAD HEADSPACE, HOW IT COULD BE BUILT OFF OF - STEP DOUBLING AS SEAT/BENCH. WORKING WITH THE WOOD WE HAD AND THE CONNECTIONS WE COULD MAKE WE DEBATED A BIT, DECIDED TO TEST OUT THE MOST OBVIOUS SEEMING ONE AND SEE HOW IT WORKED.

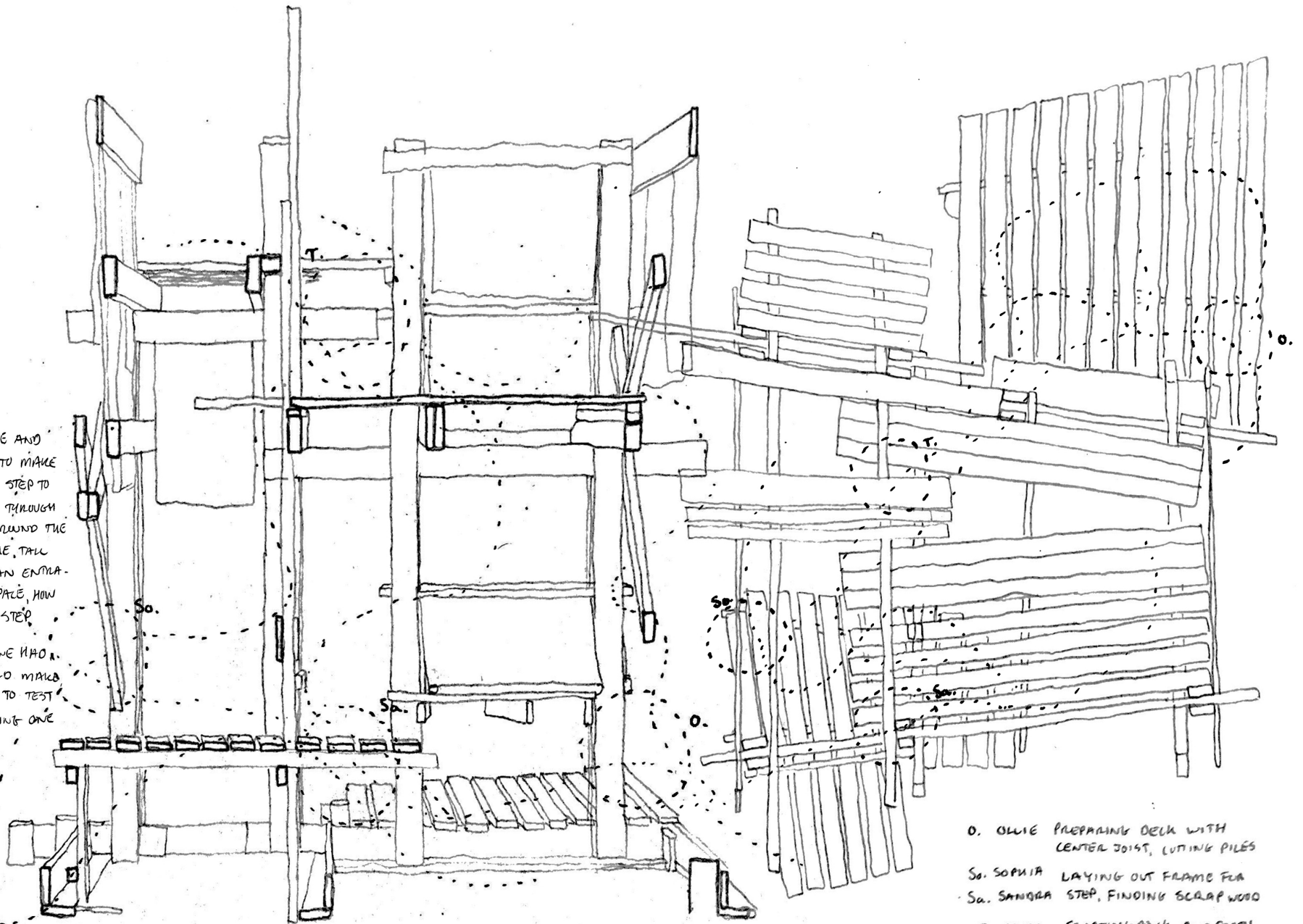

- O. OLIE PREPARING DECK WITH CENTER JOIST, CUTTING PILES
- So. SOPHIA LAYING OUT FRAME FOR
- Sa. SANDRA STEP, FINDING SCRAP WOOD
- T. TOMI FLOATING BACK AND FORTH, ACCOUNTING FOR DECK WOOD



M AND Z GRABBED A HAVENSTEGER PLACE
ON SATURDAY AND ON TUESDAY WE DID A
READING GROUP SESSION IN THE SQUAT, CLOSELY
GOING OVER CALIBAN AND THE WITCH TOGETHER.
Z BROUGHT UP THAT THE HISTORICAL ACCOUNT
WAS BOTH POWERFUL AND ESSENTIALIST - AND
WE REFLECTED TOGETHER ON WHAT A NON-
ESSENTIALIST HISTORY OF BIO POLITICS AND
PRIMITIVE ACCUMULATION (FROM THE FACTS OF
VIOLENCE AGAINST AND SUBJECTION OF WOMEN,
SLAVERY, COLONIALISM, PROLETARIANIZATION, AND THE
ENCLAVE OF THE COMMONS - AS A MESHWORK
OF INFLUENCES) WOULD LOOK LIKE. WE DRIFTED
TO STENGERS AND USMADSKIS, AND THE
PARLAMENT OF RINGS, AND BACK TO WEAVING
AND THE FEMINIST HISTORIES OF GATHERING
(UNDER THAT PRETEXT) AND REINTRODUCED
THE IDEA OF A FABRIC SESSION AT TENDER CENTER
AND WALLS OF STILKS - OF INHABITATION,
CLIMBING LINES, MESHWORK, RESISTING BY
SLOWING DOWN, WEAVING TOGETHER.

EMILY AND OLIE HAD WORKED TOGETHER BEFORE AND WERE QUICKLY ENGAGED PLAYING AND DEBATING HOW THE PLATFORM COULD BE Laid OUT - THE BEST USE OF WOOD, THE UNCONVENTIONAL NON-SQUARE PLAN, AND LEAVING A PLAYFUL STRUCTURE OF BEAMS AND GAPS TO BRANGLING ON AND FIND SEATS. A BARTUP MADE THE LIBRARY INTO A STEP AND A HANG OUT SPOT.

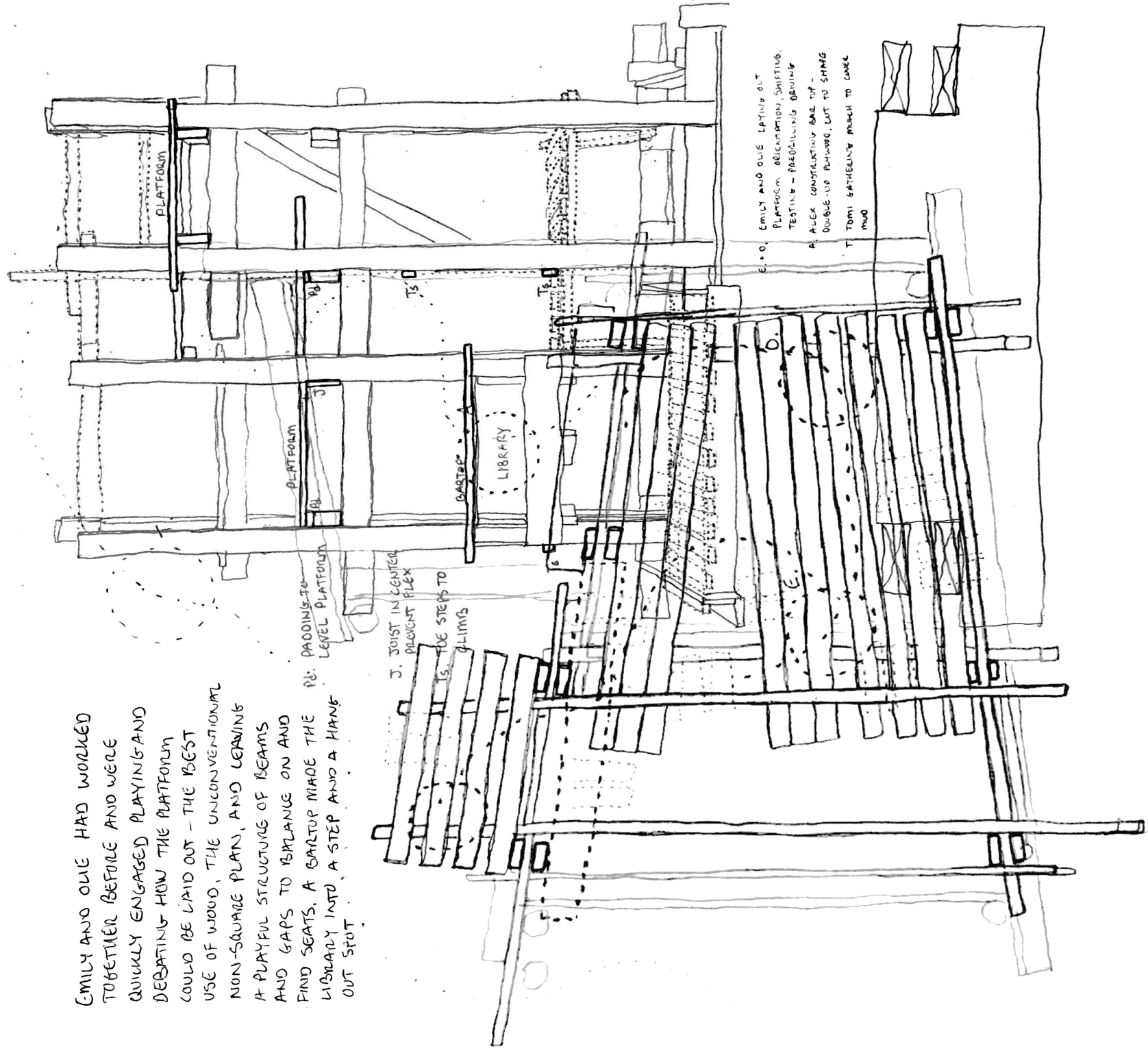

P. PADDOING TO LEVEL PLATFORM

J. JOIST IN CENTER
P. PADDOING TO LEVEL PLATFORM

S. TOE STEPS TO GLIMS

PLATFORM

PLATFORM

BARTUP

LIBRARY

E. O. EMILY AND OLIE LAYING OUT PLATFORM, DEBATING, SHIFTING, TESTING - PROPOSING BEARING
A. ALEX CONSTRUCTING BAR UP - DOUBLE-UP PLATFORM, CUT TO SHANE
T. TOMI GATHERING MUD TO CAUSE MUD

THE NEXT DAY SANDRA AND I WENT
BACK TO PUT IN THE REST OF THE
SCREWS AND MEASURE THE BEAMS.
THE SKY WAS CLEAR AND THE
SUNSET WAS A CLEAN FADE FROM
YELLOW TO BLUE

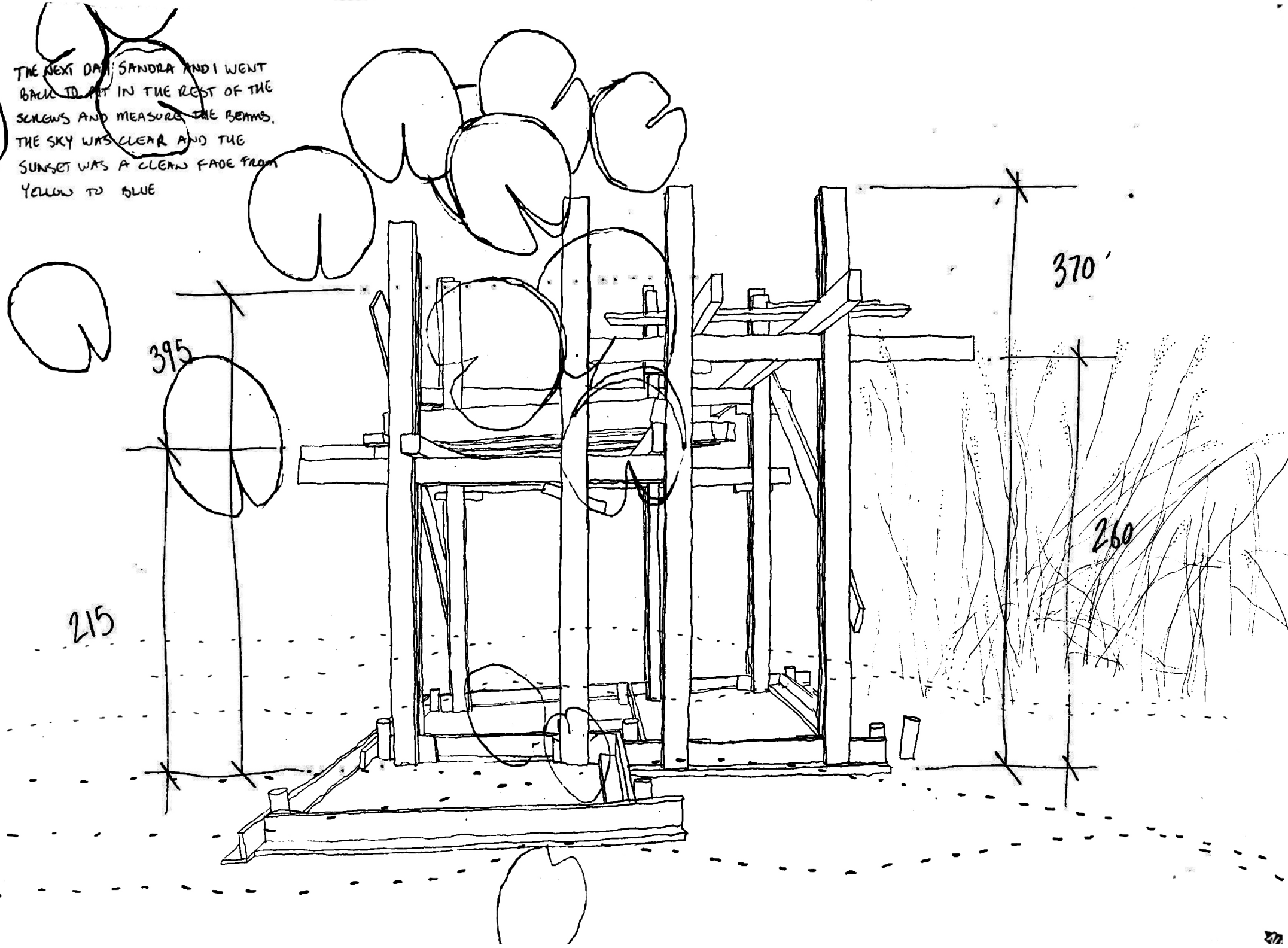

TOMI: I FEEL LIKE THIS ACADEMIC ENVIRONMENT CULTIVATES SUCH AVOIDANCE - EVERYONE IS GOING AROUND USING THIS MIL SPEAK, AND BEING SO STRATEGIC - SINCE YOU HAVE TO ASSUME EVERYONE IS JUST TRYING TO EXTRACT THINGS FROM YOU OR JUDGE YOU, WHICH IS TRUE... BUT THEN EVERYONE IS JUST SUSPICIOUS OF EACH OTHER, AND OF ENGAGEMENT

SANDORA: YES, IT RESEMBLES MY MOMENT THAT PEOPLE PRIORITIZE THESE INSTITUTIONS OVER... LIFE!

TOMI: ME AND ALEXANDRO WERE TALKING ABOUT THIS, AND WERE SAYING THAT WHEN ITS LIKE THIS, IT JUST PRODUCES A NOT-INTEREST, LIKE IN NEVER ENDING STORY.

SANDORA: YES, THATS EXACTLY HOW IT FEELS. YOU CAN LIVE, ONCE YOU'VE COMPLETED ALL LEVELS OF INSTITUTIONS, BUT ITS LIKE THESE VIDEO GAMES WHERE AT THE END, NEW LEVELS EMERGE

TOMI: AND THEN THE INSTITUTION REPLACES LIFE AS THE ONLY SAFEGUARD THAT YOU HAVE AGAINST THE INSTITUTION...?

ITS THE SAME IN THE ART / CRITICAL OPINION COMMUNITY TOO, LIKE WE WERE SAYING

SANDORA: YES, I THINK JUST GENERAL STATE OF THE WORLD... OR "OUR" WORLD

IN LIVING A FEMINIST LIFE AIMED AT SOME POINT MENTIONS HOW WHEN YOU REFUSE TO UNDERSTAND, PEOPLE THINK YOU ARE UNABLE TO, THAT IF ONLY YOU UNDERSTOOD, AND FOLLOWED SUIT, EVERYTHING WILL BE FINE. I FEEL A LOT LIKE THAT, THAT PEOPLE THINK IM DUMB AND UNABLE. AND IN WAYS I AM I GUESS. BUT I TAKE IT SERIOUSLY. I KEEP THINKING OF THE 50'S, EVERYONE LIVING IN THESE FANG BUBBLES...

WE'RE IN SOMETHING SIMILAR AGAIN I THINK, BUT THEN PINKWASHED, WORKING THROUGH DECADES OF SOCIAL EXPERIMENTS OF CONTROL... ACTIVISM (CAPTED AND BRAND-ED). EVERYONE RUNNING THROUGH THESE CONTROLING PATTERNS, NOT ENGAGING WITH THE WORLD BUT PRETENDING THEY CARE... SIMULATED PRECARIATY

ITS STRANGE HOW SLOW LIFE IS, HOW MUCH ENERGY IT TAKES TO BUILD AND SUSTAIN RELATIONSHIPS. BUT ITS SO COMMON YOU LEAVE YOUR MUSE AND TOWN WHEN YOU GO STUDY, TO MOVE ABOUT LOOKING FOR JOBS. I THINK THIS WILL JUST INCREASE, THAT THEY WILL KEEP SPLINTERING COMMUNITIES, BECAUSE IT MAKES US WEAK, UNABLE TO REALLY RESIST. TO RESIST TAKES SOME COMMITMENT, BUT SAID OUT LOUD, AMONGST EACH OTHER. AND I MEAN, IN LIVING ROOMS OR MAYBE BY A TREE.

BUT NOT IN A PROGRAMMED EVENT AT NAI, OR TV DEPT, OR WHATEVER.

TOMI: YEAH, THATS TRUE, IT IS LIKE THAT. IM GUILTY OF THE FIRST PART

SANDORA: YES, ME TOO WE'VE BEEN TALKING ON THIS TOPIC A LOT BY THE WAY. IF THERE ARE THINGS IN MY WAY YOU'RE CRITICAL OR UNSURE OF, DO LET ME KNOW. I MEAN, I THINK I AT LEAST TRY TO BE SOMEWHAT UPFRONT ABOUT MY FEELS AND DISTRUST OF PEOPLE.

TOMI: I DONT HAVE ANY ISSUES WITH WHAT YOU'RE SAYING, IF THATS WHAT YOU MEAN. I THINK WE RELATE ON PARTS OF THIS FRUSTRATION WITH LACK OF ENGAGEMENT GENERALLY

SANDORA: YES ITS DIFFICULT IF NOT IMPOSSIBLE TO MAKE PEOPLE CARE. THEY CAN ONLY DO THAT OUT OF THEIR OWN MOVEMENT, BUT TABLES SO MUCH DISTRACTION

TOMI: YES

SANDORA: I GUESS I WANT PEOPLE TO CARE FOR SELFISH REASONS, CAUSE I NEED OTHERS TO SURVIVE. OR I THINK I DO. OR I THINK A WORLD WITH SO MANY PEOPLE NEEDS US CARRYING FOR EACH OTHER, TO BE MINDFUL

TOMI: ITS THIS THING WE WERE TALKING ABOUT - WHETHER SOMEONE IS DISTANT BECAUSE THEY FEEL BLOCKED, ARE BEING CAREFUL, OR IF THEY ARE BEING JUDGMENTAL/SUSPICIOUS, OR EVEN IF THEY ARE SEEING IF THEY CAN EXTRACT SOMETHING. ALL YOU CAN DO IS OFFER FRIENDSHIP AND OPENNESS, TRULY, AND SEE WHAT ~~EMERGES~~ CAN EMERGE - AND USUALLY YOU CAN JUST FEEL IF ITS GENUINE OR NOT. SOME PEOPLE CAN USE YOU, BUT, AND MAYBE IM TOO HOPEFUL, ENGAGING DOESNT MEAN GIVING UP YOUR BOUNDARIES, BUT FINDING THEM NEW EACH TIME

SANDORA: YES, THOUGH I THINK WE RESPOND A LOT IN MESSY WAYS. AND THE ISSUES THAT AFFECT OUR COMMUNITIES SO DEEPLY, PSYCHOLOGICALLY AND SOCIALLY. IF SOMEONE IS A BRAINWASHED CAPITALIST ON EVERY LEVEL, AND MANY ARE, WE MUST REALLY WONDER HOW THIS CAN BE MADE MORE SOFT AND OPEN AND Caring OTHERWISE THERE IS NO FUTURE FOR ANYONE



PO. POST (56x150)x12
 PD. PADDING, SCAFFOLDING
 CUT TO ~30cm
 LENGTHS (38x225)
 BL. BLOCKS TO HOLD
 UP BEAMS (2x4)

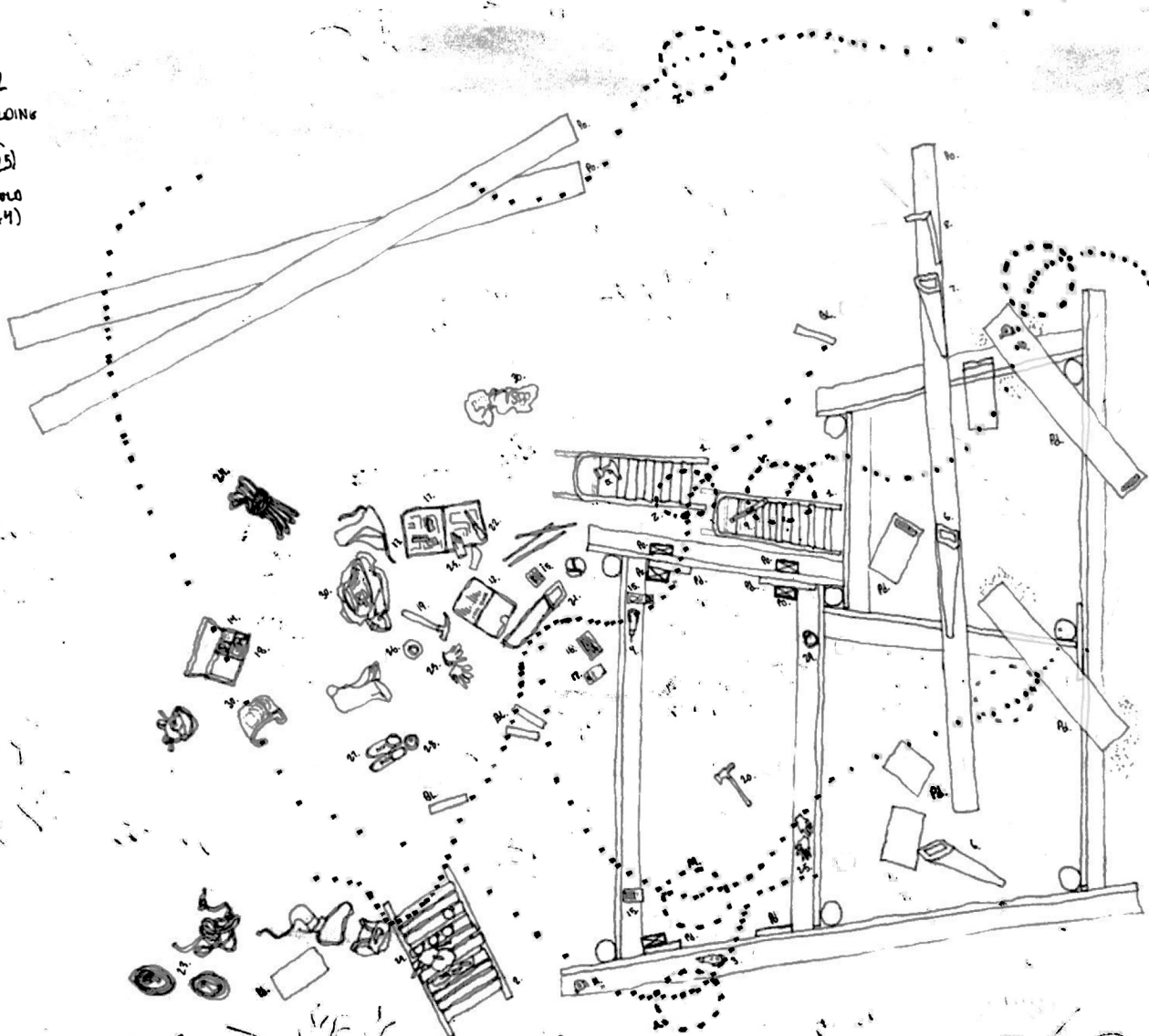

1. FOLDING LADDER (WERKPLAATS)
2. FOLDING STEP LADDER (FOVS)
3. DRILL 18V (TOMI)
4. DRILL 12V (VERA)
5. DRILL 12V (MICHELE)
6. HANDSAW (TOMI)
7. HANDSAW (WERKPLAATS)
8. T-SQUARE (WERKPLAATS)
9. LEVEL (VERA)
10. TAPE MEASURE (VERA)
11. TAPE MEASURE (TOMI)
12. DRILL DRIVING BITS (VERA)
13. DRIVING BITS (ZEYNEP)
14. DRIVING BITS (MICHELE)
15. 6x120 ANS SCREWS
16. 5x70 SCREWS
17. 18V BATTERY (TOMI)
18. 12V BATTERY (MICHELE)
19. HAMMER (TOMI)
20. HAMMER (WERKPLAATS)
21. HACKSAW (WERKPLAATS)
22. SCREWDRIVER, EXCHANGEABLE (VERA)
23. STRAPS W/ RATCHET (MICHELE)
24. ROPE (TOMI)
25. GLOVES
26. DUCT TAPE
27. BOOTS (UNISECO)
28. WATER BOTTLE
29. COFFEE THERMOS
30. SNACKS
31. TRUCK (MICHELE)

- ANNELIKI A. DRILLING IN POSTS TO FOUNDATION BEAMS, CHECKING PROPER PADDING
- MICHELE M. HOLDING POST VERTICAL AND PLUMB, MEASURING AND CUTTING PADDING
- VERA V. ON LADDER, CHECKING PLUMB, MAKING MEASUREMENTS FOR BEAM HEIGHT
- ZEYNEP Z. TRANSFERING MEASUREMENTS, DRILLING IN BLOCKING
- TOMI T. BRINGING POSTS, THEN BEAMS, FROM TRUCK TO BUILDING SITE

ALI ARRIVED JUST IN TIME FOR
WHEN VERA AND ANGELIKA HAD TO LEAVE,
AND WE SET TO INSTALL THE LAST BEAMS.
- MICHELE PULLED ON THE STRAP, ALI
CHECKED THE PLUMB, I HELD THE CROSS
BRACING IN PLACE AND ZEYNEP DRILLED
IT IN

WE USED SCREWS INSTEAD OF NAILS, EVEN
THOUGH NAILS HAVE BETTER SHEAR STRENGTH
(FOR HORIZONTAL LOADS LIKE BEAMS, VS TENSILE
STRENGTH OF SCREWS), MOSTLY BECAUSE IT ALLOWED
US FREEDOM TO TAKE THINGS APART AND MOVE
THINGS AROUND, AND THE ACCESSIBILITY OF
WORKING A DRILL OVER POUNDING LONG NAILS.
6x12 SCREWS ARE STRONG ENOUGH

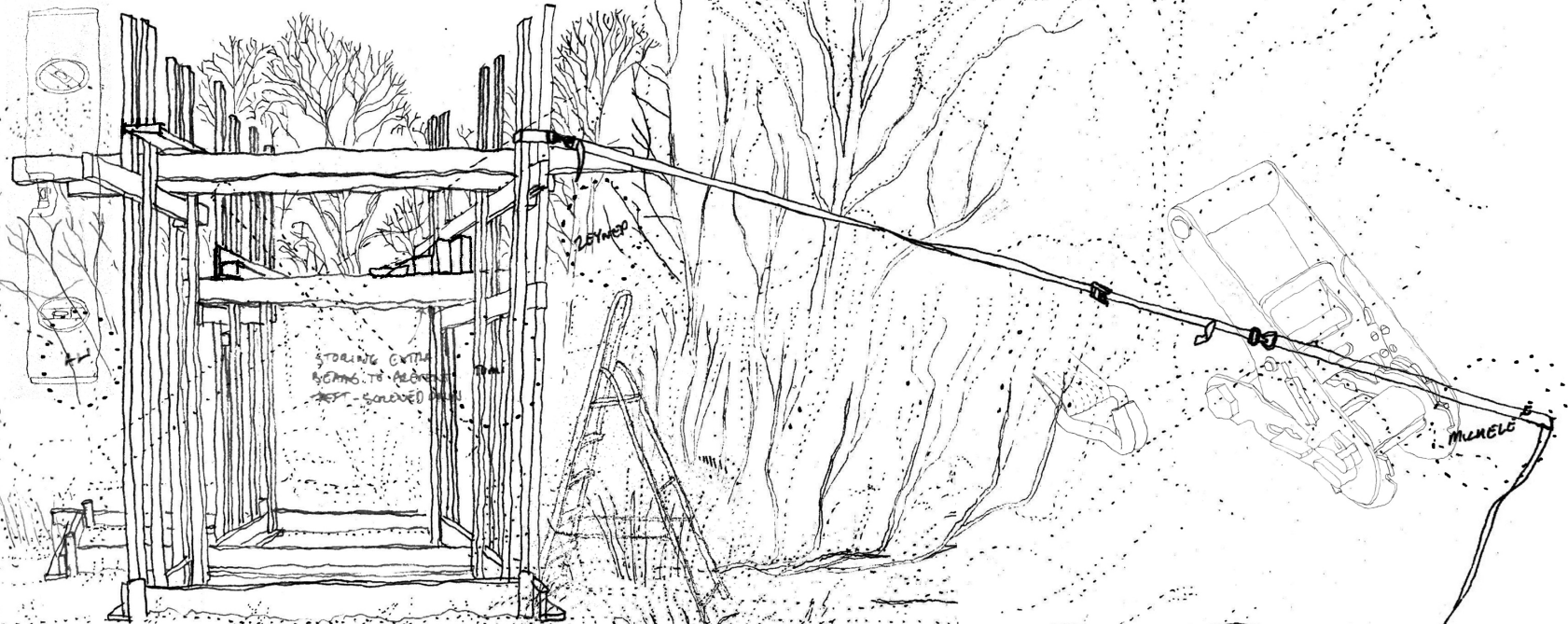

I WAS SHARING THE LOGIC OF THE THINKING THAT HAD BROUGHT US TO THIS STRUCTURAL OUTLINE, AND THE THINGS WHICH WERENT YET RESOLVED, AND THE POSSIBILITIES ABOUT WHAT COULD BE DONE, AND THE THINGS THAT WOULD NEED TO BE CONSIDERED, OR RAMIFICATIONS OF DOING A THING.

AND FROM THERE WE STARTED DISCUSSING THROUGH TESTING THINGS OUT, AS A GROUP, AND IN PAIRS - WHICH WORKS BECAUSE EVERYONE WANTS TO BE THERE, AND SHARE SOME FAMILIARITY, AND COMFORT.

WE DECIDED ON STAGGERING TWO BEAM HEIGHTS, TWO FLOORS? IT FELT RIGHT. LET'S DO IT AND THEN SEE - SEEMS OPEN. TO GET THE CROSS BEAMS LEVEL THE BEAMS THEY REST ON HAVE TO BE THE SAME HEIGHT, BUT THE GROUND ISN'T LEVEL. EVERYONE HAS TO THINK AND COMMUNICATE TOGETHER TO GET IT RIGHT. ITS THE FUN PART.

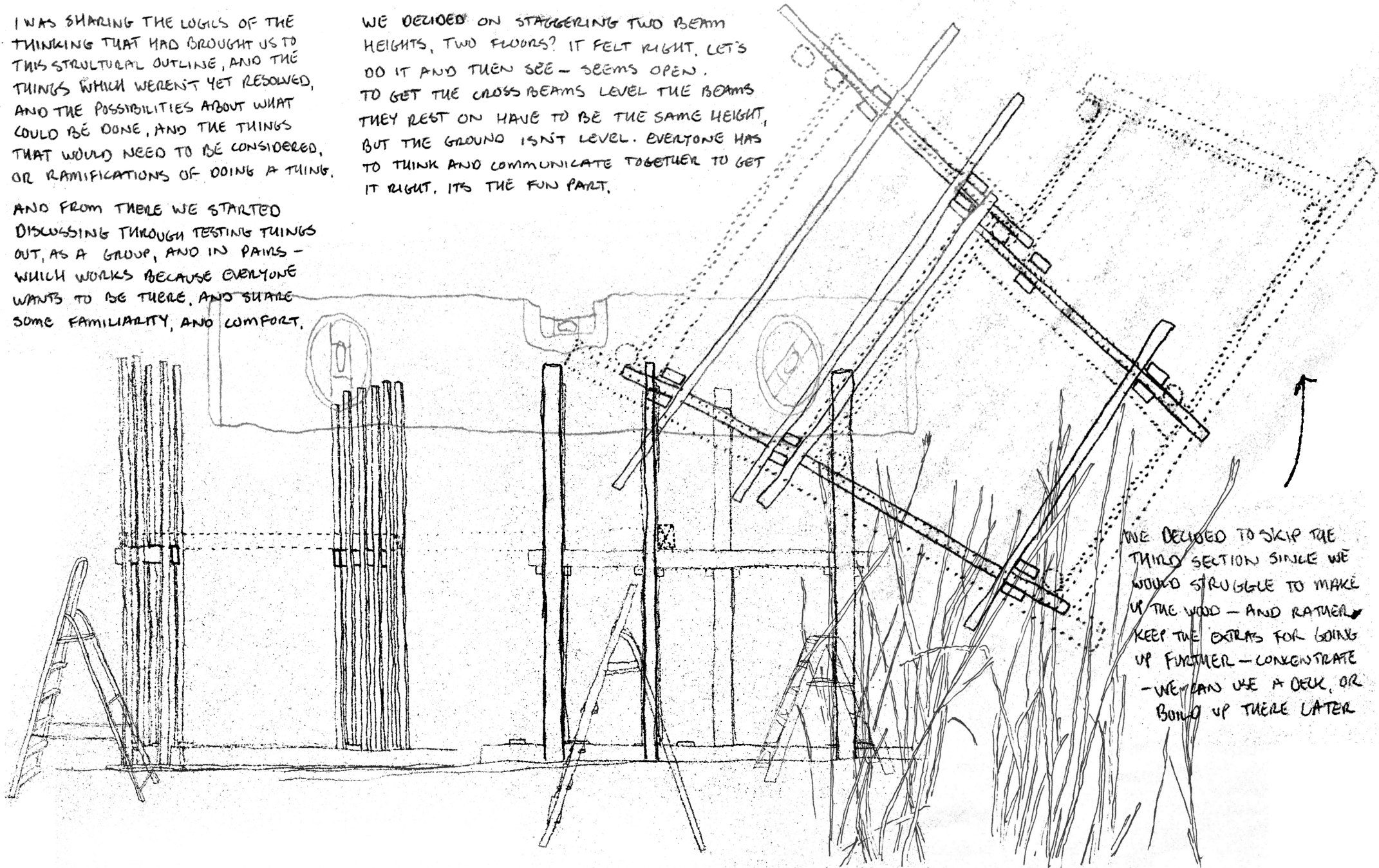

WE DECIDED TO SKIP THE THIRD SECTION SINCE WE WOULD STRUGGLE TO MAKE UP THE WOOD - AND RATHER KEEP THE EXTRAS FOR GOING UP FURTHER - CONCENTRATE - WE CAN USE A DECK, OR BOND UP THERE LATER

THE MILKERS, AND CAMILLA PULLED THE WOOD OUT INTO THE WORKPLACES TO ACCOUNT FOR WHAT WE HAD AND WHAT WE COULD DO WITH IT TOMORROW. ALBERTO SUGGESTED PASTS ON EITHER SIDE OF THE BEAMS TO EXTEND FROM THE FOUNDATION. WE HAD 12 GOOD PIECES OF CONSISTENT SIZE WE COULD USE FOR PASTS - ALSO GIVES A GOOD LOOK - AESTHETICS ARE ALWAYS IN THE BACK OF THE MIND, NOT JUST FOR LEGITIMACY APPEARANCES.

ITS ENOUGH TO START (WITH WHAT WE KNOW), WE'LL FIGURE THE REST OUT WITH THE OTHERS WHEN WE CAN PLAY WITH IT.

THE REST OF THE SIZES AND LENGTHS VARIED, SO WE HAD TO THINK ABOUT IT - THINK AHEAD - TO SEE IF IT WAS POSSIBLE. WE COUNTED, AND TALLIED BY SPEAKING, NOT WRITING IT DOWN, OTHER THAN TO COMMUNICATE AN OVERALL SKETCH TO EACH OTHER. WE MIGHT HAVE ENOUGH IF WE SHIMMY THINGS, AND DEPENDING ON WHERE WE WANT TO PUT THINGS ONCE WE GET THERE, OR IF WE WANT TO MAKE CUTS, OR IMPROVISE WITH SMALLER PIECES.

WE MADE A TALLY OF TOOLS WE MIGHT NEED, THINKING ABOUT STUCKY SITUATIONS WE MIGHT NEED TO GET OUT OF. ALSO IF THERE WERE ENOUGH TOOLS, PARTICULARLY DRILLS, AND ACTIONS TO KEEP EVERYONE BUSY. I'D MUSTLY UNLOAD THE WOOD TO GIVE SPACE TO EVERYONE ELSE TO THINK THROUGH BUILDING, IT WILL BE THE FIRST TIME I INVITE A GROUP TO COME, WHO DON'T ALL KNOW EACH OTHER, BUT THEY ALL KNOW THE PROJECT

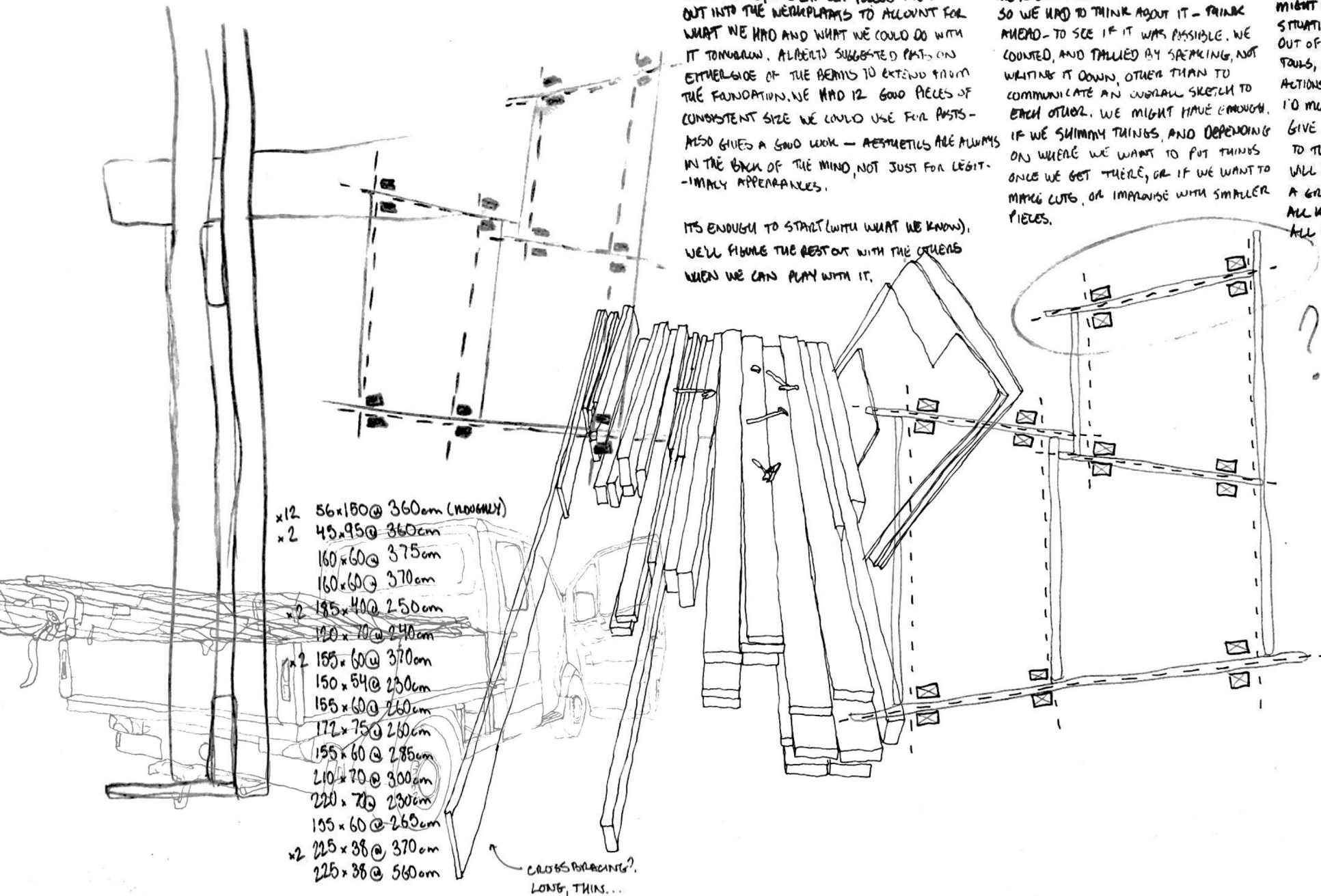

THE PREVIOUS NIGHT I ARRIVED TO FIND TWO MORE BEAMS STOLEN - I HAD ALREADY TIGHTENED THE SIZE OF THE FOUNDATION TO ACCOUNT FOR THE STOLEN PREVIOUS BEAMS, BUT THESE WILL NEED TO BE REPLACED... WHO ARE THESE PEOPLE WHO SEARCH IN THE BUSSES? YOU'D NEED A TRUCK TO CARRY THESE AWAY. WHY TAKE FROM SOMEONE YOU DON'T KNOW? DOING SOMETHING YOU MIGHT ENJOY? ANGER MOVES IMMEDIATELY TO SADNESS.



I PLACED THE ORDER AT ABLAS - FONS AGREED TO PARK THE VAN THERE ALREADY FOR ME TO PLACE THE BEAMS INTO, AND THEY'D RETURN LATER TO DRIVE IT HOME. I CONTINUED TO ALEXANDRIUM TO BUY AN 18V MAKITA I SAW ON MARKETPLACES FOR A GOOD PRICE. AFTER A DAY AT THE BIKE SHOP, I CONNECTED WITH ZEYNEP TO BUILD TONIGHT AND USE THE BAKFIETS TO MAKE THE NEW BEAMS. TIRED AND EXHAUSTED, FROM THE PROUD ROUTE WITH THE HEAVY BAKFIETS TO AND FOR LUK HUIS, AND THE COMPLETING OF THE FRAME - WE STOPPED FOR LONG CHATS TOO - IT WAS 5AM BY THE TIME WE RETURNED, CRASHED IMMEDIATELY IN THE COLD SQUAT.

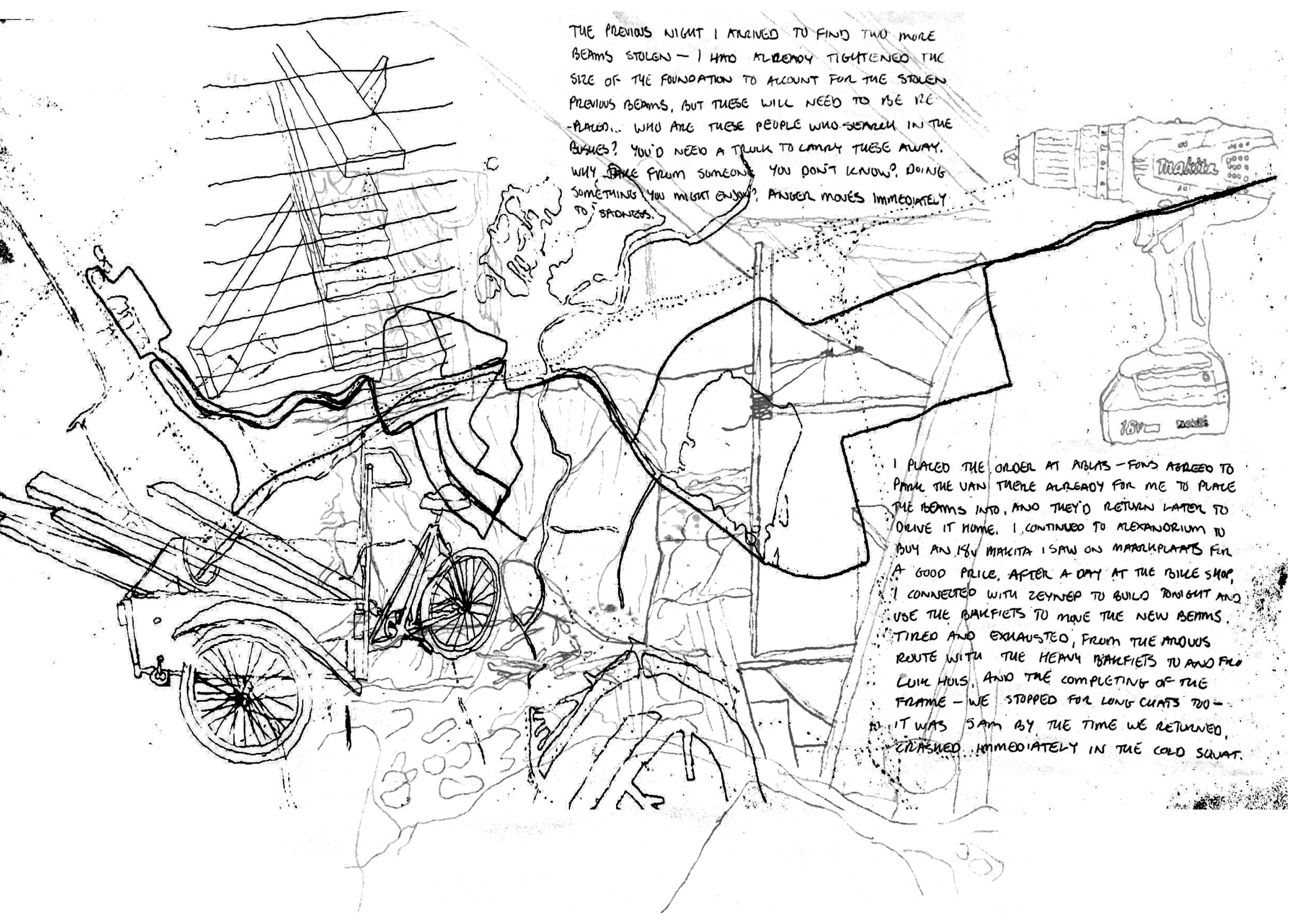

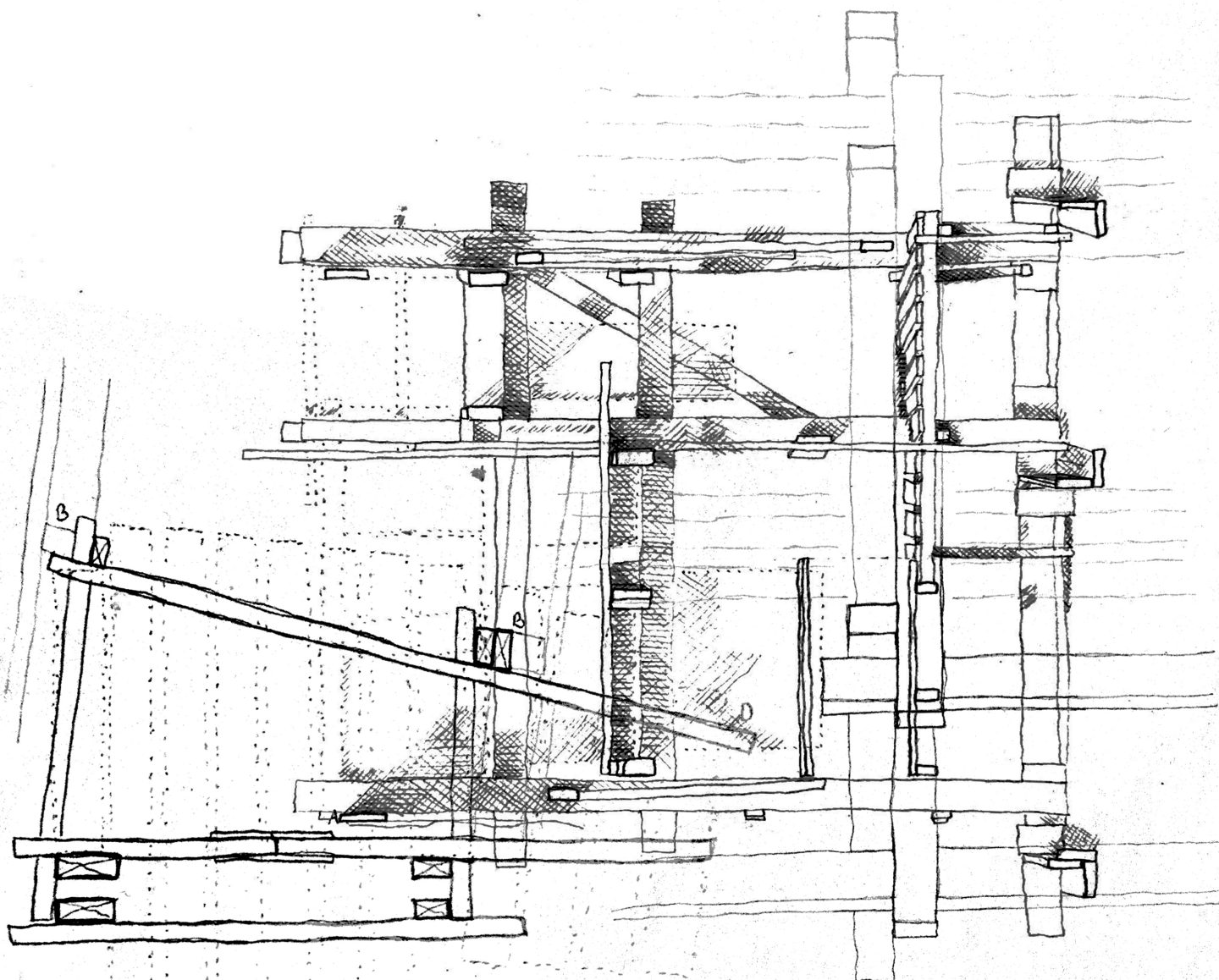

- A TWO SHORT BEAMS MADE INTO ONE LONG WITH PLYWOOD SANDWICH
- B POST ATTACHED WITH BLANKING TO GROUND BEAM
- C BEAMS EXTEND SO AS TO NOT HINGE TO CUT-YET - CROSS BRACING ADDED LATER
- D BEAMS EXTEND SO AS TO KEEP ALTERNATING PLATFORM OPEN - HOLDS CUT OFFS FROM DECK

C