

# Asplund I Research Plan

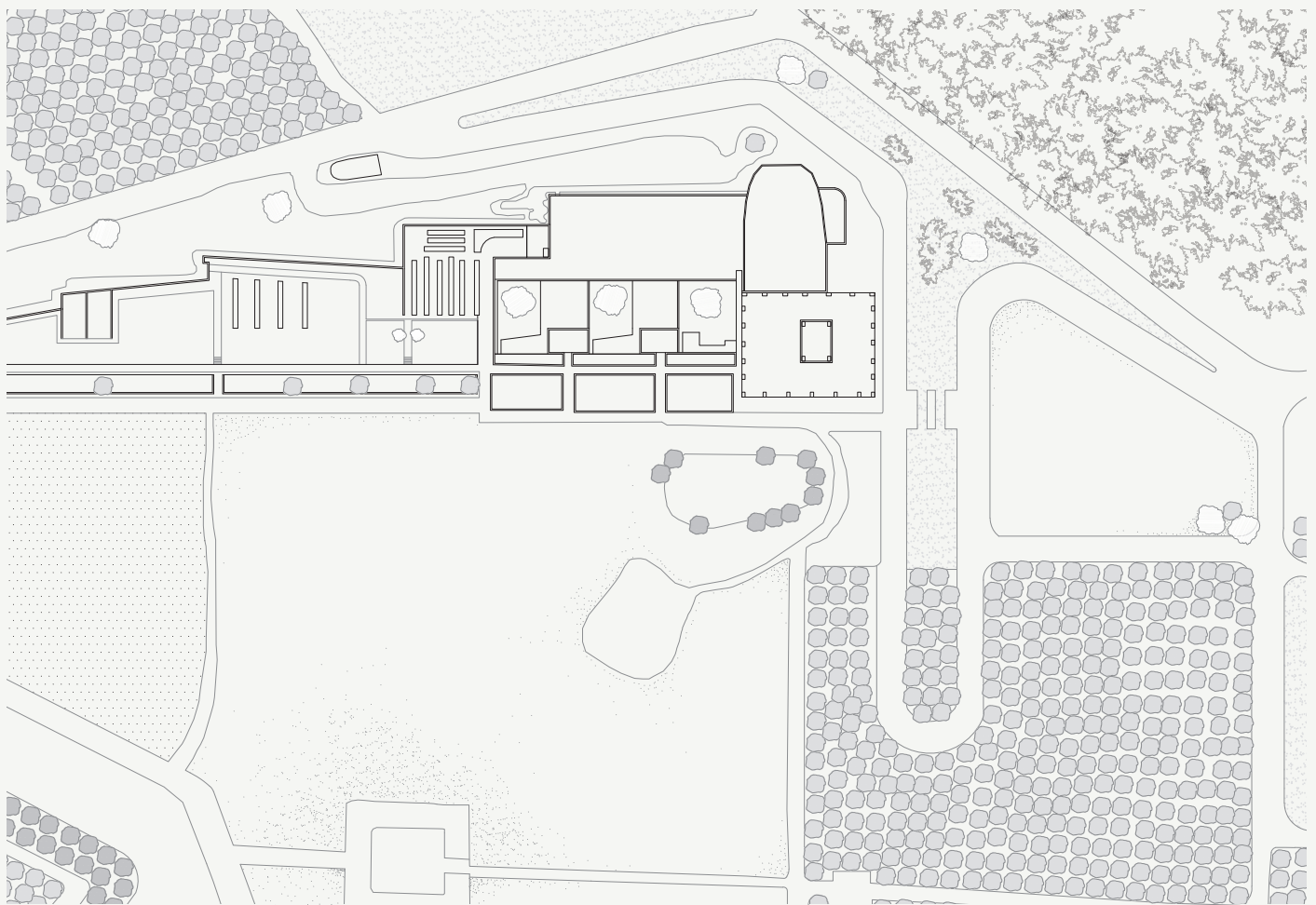

*by Snigdha Ray, Julia Palega, Sora Kaito and Janis Kivlinieks*

# Introduction

The document is a collection of Research Investigations conducted by the group across precedents from the architect, Gunnar Asplund's projects and Modern Libraries across world in response to brief of re-envisioning the Stockholm Central Library, in Sweden. Through the conducted analyses and via the various precedents studied, apparent themes of designing libraries, public spaces and understanding the architect's methodologies to certain sensitivities emerge.

The series of writings present our findings, and highlight our responses to several aspects of the design of these symbolic buildings. The research unfolds buildings from the exterior to detail analysing aspects of Spatiality, Composition, Landscape and Ornamentation. This further helps formulate our positions with regards to the final design assignment.

# Contents

## 1. **Woodland Crematorium by Gunnar Asplund**

Collective Research with Collection of existing drawings and images and own Analysis Drawings

## 2. **Berlin zu Stadtbibliothek by Hans Scharoun**

Collective Research with Collection of existing drawings and images own Analysis Drawings

## 3. **Post-P1: Final Thoughts**

Individual Texts

Group members:

*Julia Palega*  
*Janis Kivlinieks*  
*Snigdha Ray*  
*Sora Kaito*



# Woodland Crematorium by Gunnar Asplund

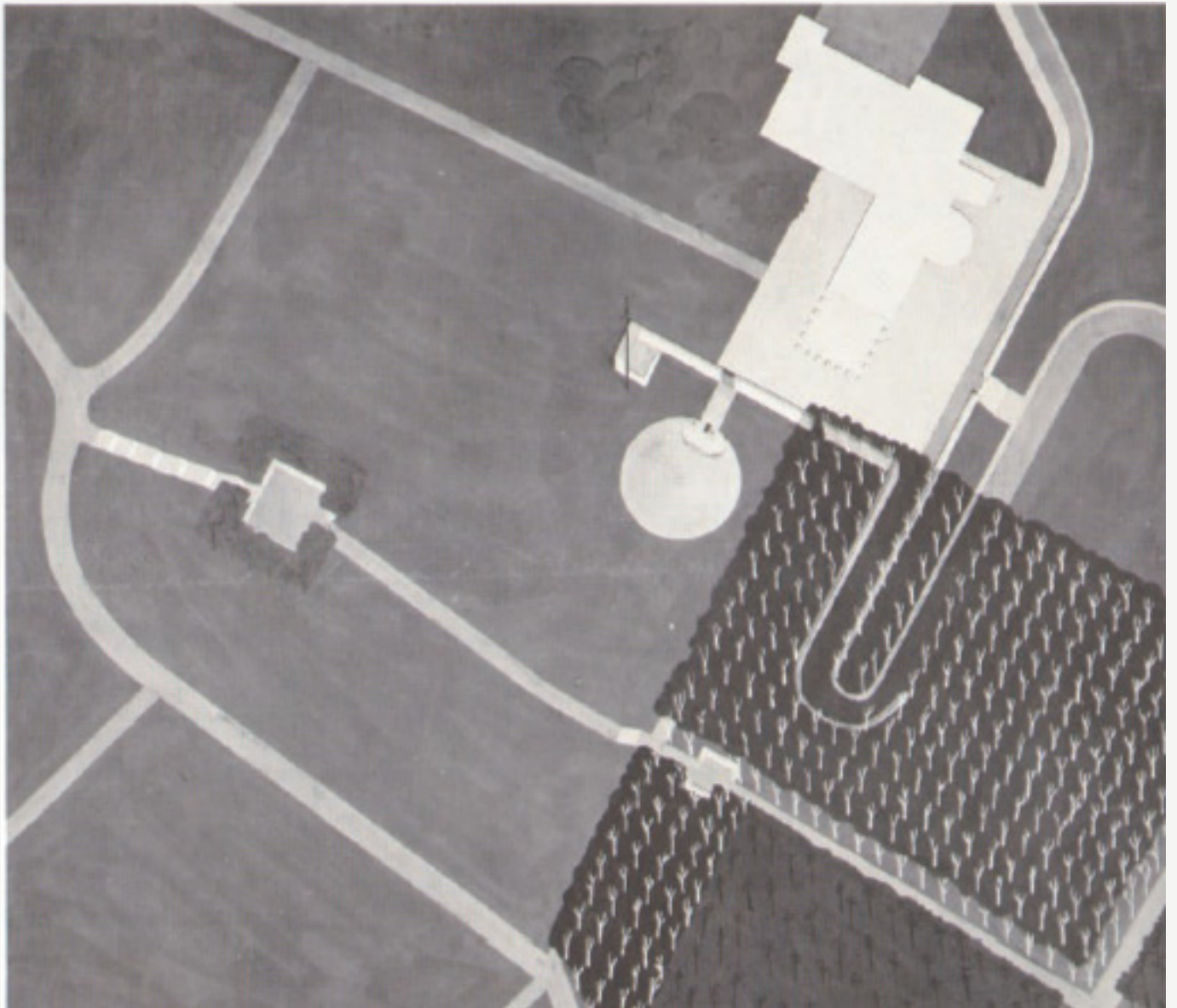

Figure 1.1 *Initial Site Concept by Gunnar Asplund and Sigurd Lewerentz*

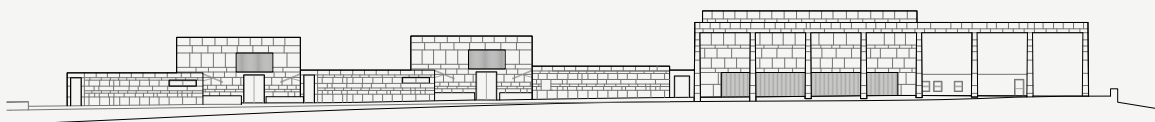

Figure 1.2 *The Longitudinal Elevation depicting various Stone dimensions*

## The Woodland Crematorium by Gunnar Asplund

*Collective investigation response*

In our part of the overall investigation of Gunnar Asplund's work, we examined the Woodland Crematorium. This building was constructed towards the end of the architect's life, representing his more functionalist approach to architecture. The Crematorium is part of a cemetery complex designed along with Lewerentz, an intelligible and legible building standing out against the powerful and romantic surrounding landscape. It consists of precisely three chapels and three courtyards that linearly become part of the entrance axis of the complex.

The Woodland Crematorium was built during a period of transformation in Sweden. It had recently undergone the end of the union between Norway and Sweden, so their national goals started changing. They wanted to embrace the Swedish heritage in the form of National Romanticism and modernity following the Democratic Party<sup>1</sup>. In the cemetery, the main aspect of Swedish heritage, which Asplund and Lewerentz wanted to embrace is the local pine forest, which builds the context of the crematorium. (Figure 1.3) At that time, in Sweden emerged an important political concept, called 'Folkhemmet', which is about society helping one another and looking after each other. It indicates, that the government wanted to be more inclusive. It is reflected in the Crematorium's multi-religious and rather symbolic, not Christian expression<sup>2</sup>. (Figure 1.11)

The building is composed of three chapels and three adjacent courtyards in similar shape. (Figure 1.8) Spatially, the main feature of the woodland crematorium is the collaboration between architecture and the landscape. Those defined and enclosed outdoor spaces blur the lines between the inside and outside. The chapels however do not provide a view of the courtyards, to distinguish the area for conducting services from the meditative spaces.<sup>3</sup> Each of them has a corresponding waiting room so two sets of mourners never cross paths<sup>4</sup>. (Figure 1.9).

The composition of the main façade reflects the functions of the building. Waiting rooms and courtyards are of similar height and create a visual plinth, for the higher Chapels (Figure 1.2). The main focal point is the loggia located asymmetrically in front of the Chapel of the Holy Cross. This arrangement divides the terrace into two sections: one for formal ceremonies, featuring an openable Chapel wall, and the other, a less formal space (Figure 1.7).

Gunnar Asplund in the design of the crematorium uses symbolism to reflect on the meanings of life and death. This is prominent both in the design itself and its details. In the chapel of the Holy Cross, he uses the means of a curved wall to resemble a burial cave<sup>5</sup>. Additionally, the burial ovens resemble the shape of a coffin (Figure 1.16). Through architecture, he asks metaphysical questions about existential significance.

Asplund has treated the relationship of this building with the landscape with great care. He embraces both the small moments, like pavement leading to the building, and a small clock placed subtly on the site, and the monumental landscape. There are two routes leading to the crematorium: a Christian one with a consolidating cross on the path, and a non-Christian one through the meditation Grove<sup>6</sup> (Figure 1.5) Additionally, the landscape plays a big role in experiencing this building as it presents itself to the mourner framed by the loggia, providing comfort in the time of loss (Figure 1.4).

The most important aspect of the building is its relation to the magnificent landscape, which we tried to capture through our essence drawing (Figure 1.22). The building on the left opens up through the courtyards to the pond and the landscape. The vertical arrangement of the drawing highlights the stone path, leading mourners through the cross and alongside the façade of the main chapel. Drawing encompasses an ordered and functional composition of the building in relation to the monumental landscape, which is emphasised more than the architecture. This relationship between the building within its surroundings is something that can be used later in our designs.

1 Mary Woolen, *Erik Gunnar Asplund: Landscapes and Buildings* (Routledge, 2018), 5-17.

2 Woolen, *Erik Gunnar Asplund*, 82.

3 Woolen, *Erik Gunnar Asplund*, 130-131.

4 Stuart Werde, *The Architecture of Erik Gunnar Asplund* (MIT Press eBooks, 1980), 00-00, <https://doi.org/10.7551/mitpress/1328.001.0001>.

5 Werde, *The Architecture of Erik Gunnar Asplund*, 204.

6 Woolen, *Erik Gunnar Asplund*, 116.



Figure 1.3 *Landscape Woodland Crematorium, Stockholm, Photograph by Andy Liffner*



Figure 1.4 *View of the Crematorium complex from the Pavilion and through the loggia, Photograph by Andy Liffner*

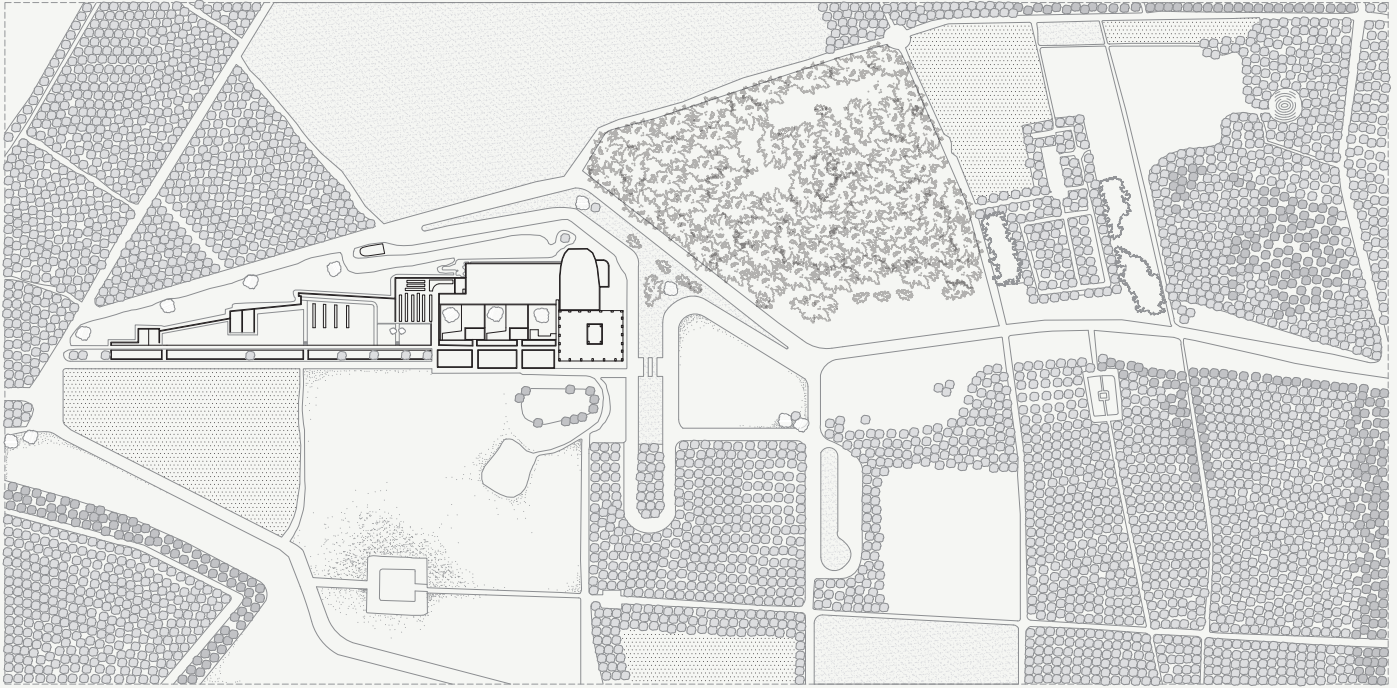
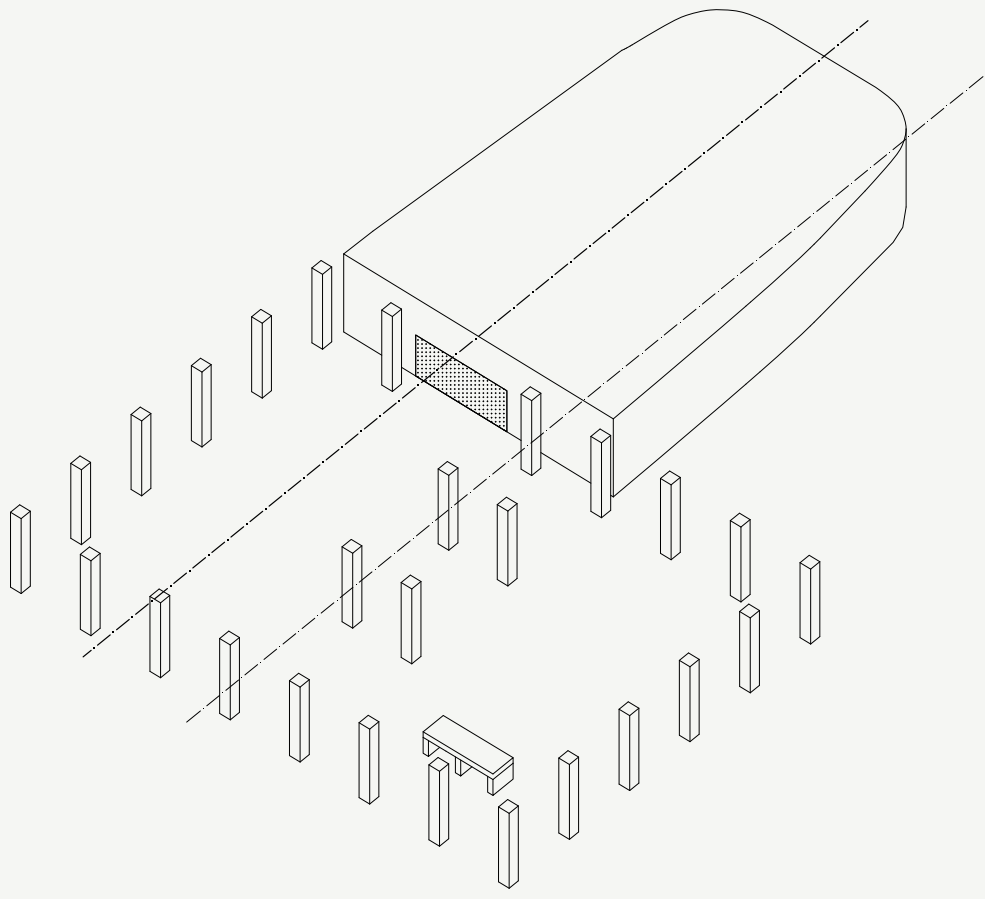

Figure 1.5 Site of the Woodland Crematorium, Stockholm, The site is embedded in the contour, designed by Lewerentz



Figure 1.6 The columns form a portal for mourners exiting from the ceremony to the outdoors, The route to the landscape is also clearly visible through the axis, Photograph by Andy Liffner





*Figure 1.7 Building Axonometry*

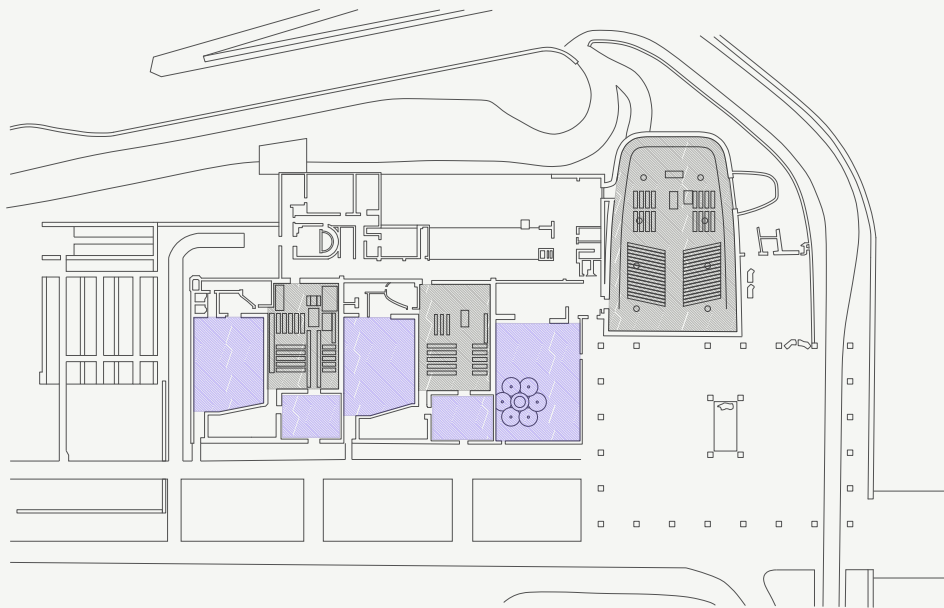

Figure 1.8 The Chapel of Faith, Hope and Holy Cross

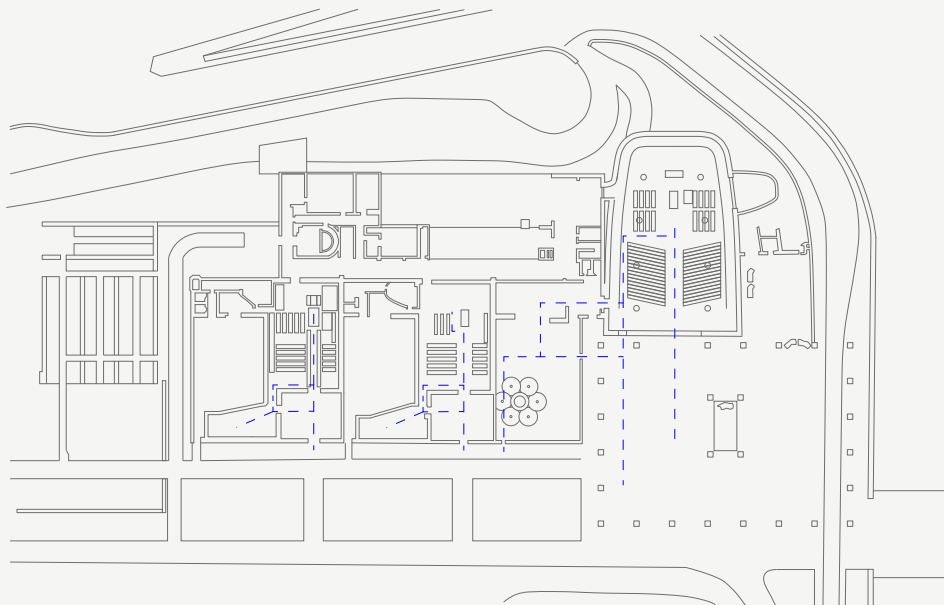

Figure 1.9 Plan indicating analysis of Route

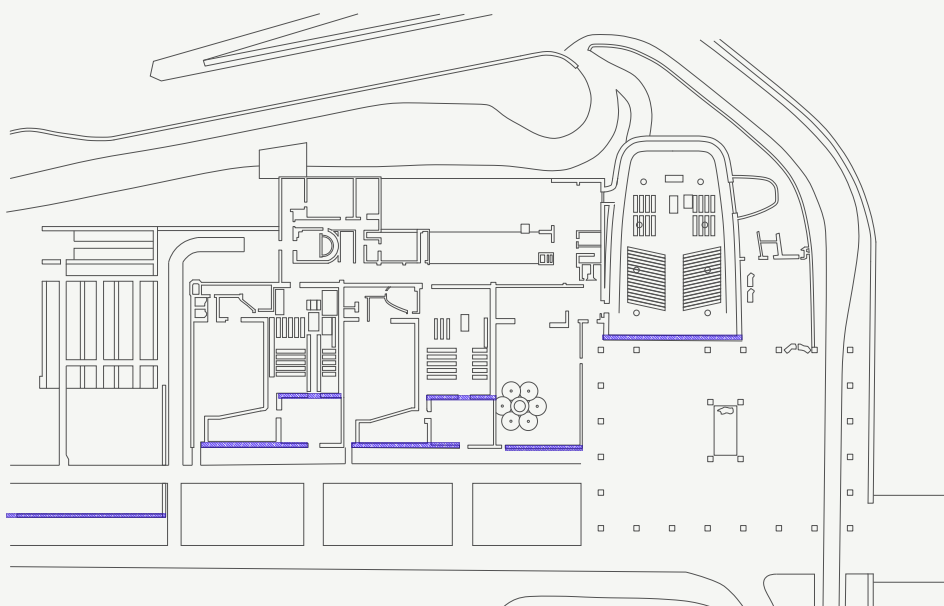

Figure 1.10 Plan indicating analysis of spaces and courtyards



Figure 1.11 Series of images of interiors of the three chapels with especially designed furnishings as evident through the light fixtures frescos, and ornaments.

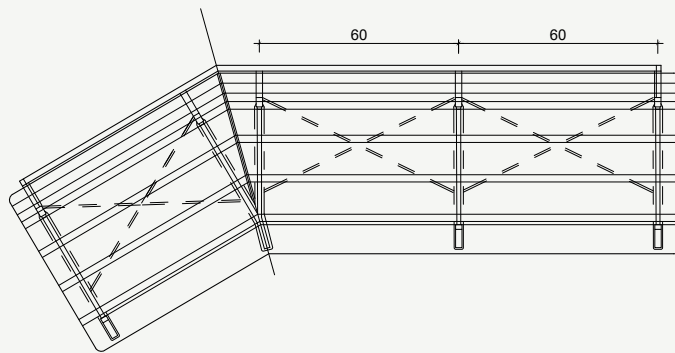
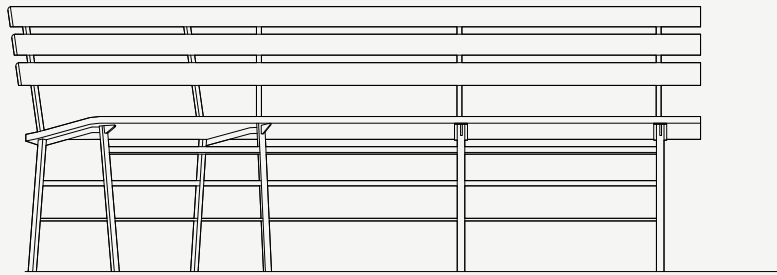

Figure 1.12 Ornamentation; Asplund's Bench, 1939

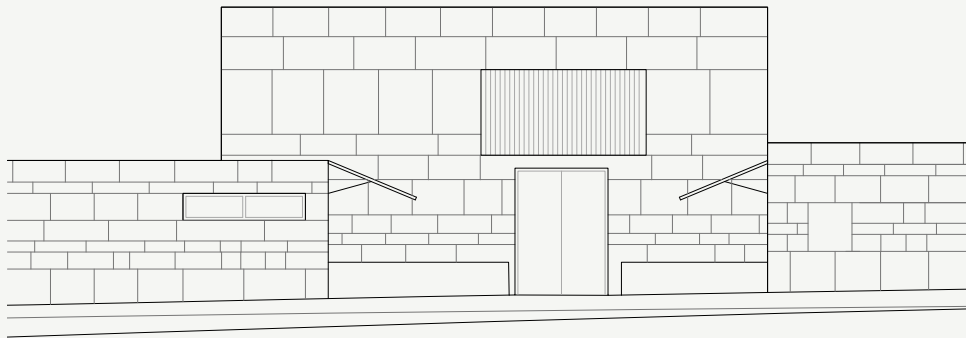

Figure 1.13 Ornamentation; Shading Structures on courtyard entrance

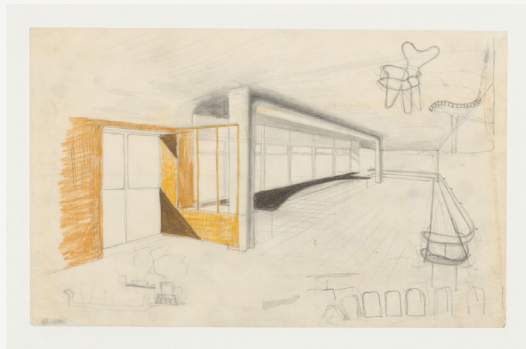
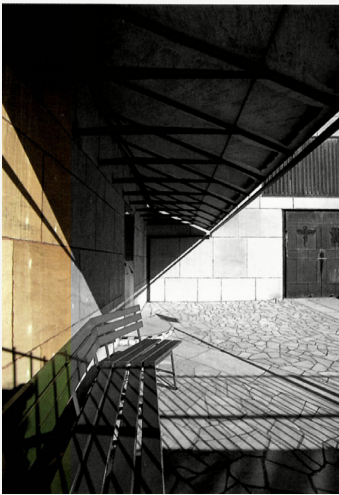
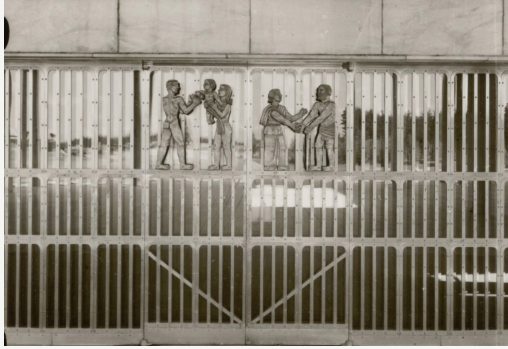

Figure 1.14 Ornamentation; details of materials in interiors and exterior pavilion

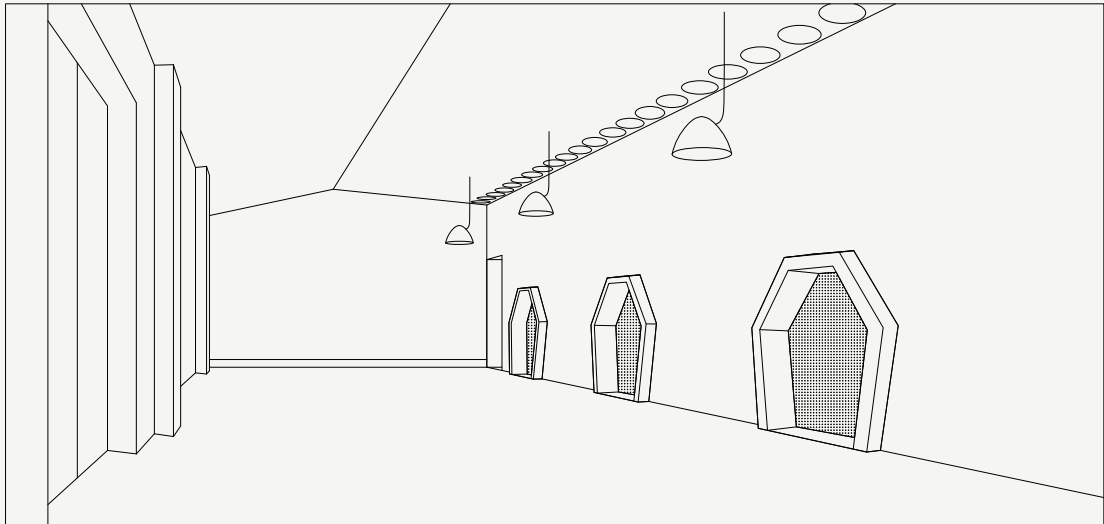

Figure 1.15 Detail; Underground ovens in the crematorium with coffin representations

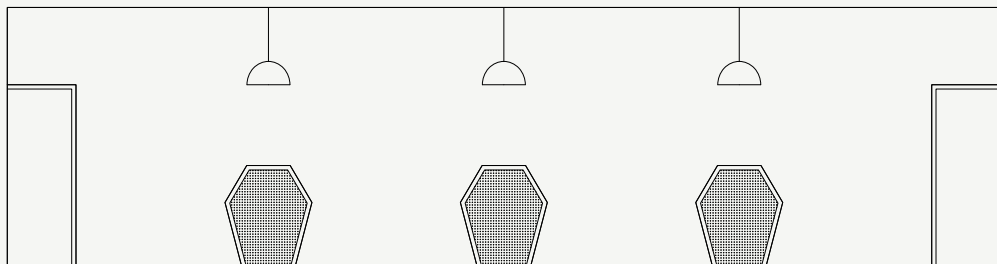

Figure 1.16 Detail; Asplund's desire for artistic representations in space



Figure 1.17 Images that were adopted in the conception for the essence drawing

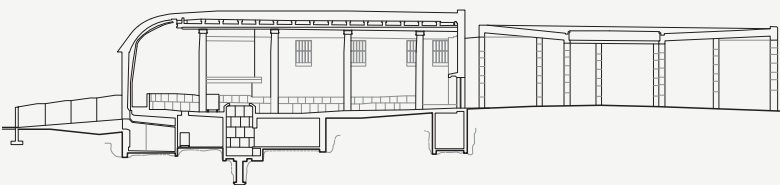

Figure 1.18 Longitudinal Section across the main chapel and pavilion

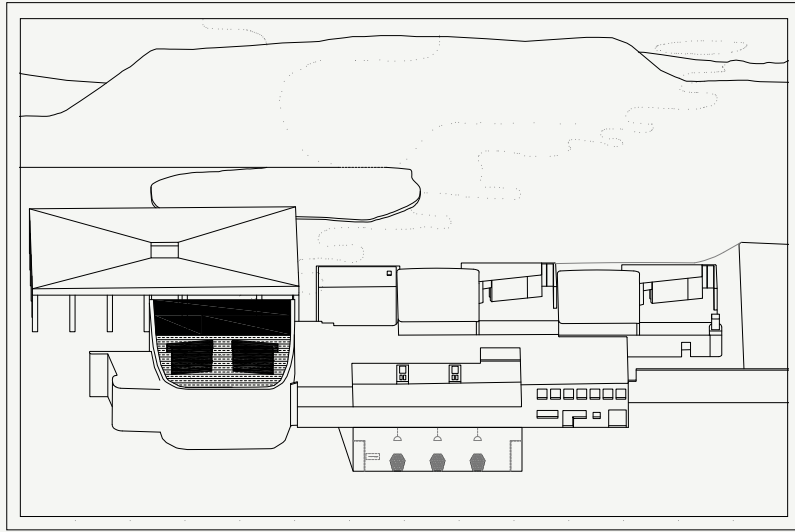

Figure 1.19 Initial view and conception of essence drawing

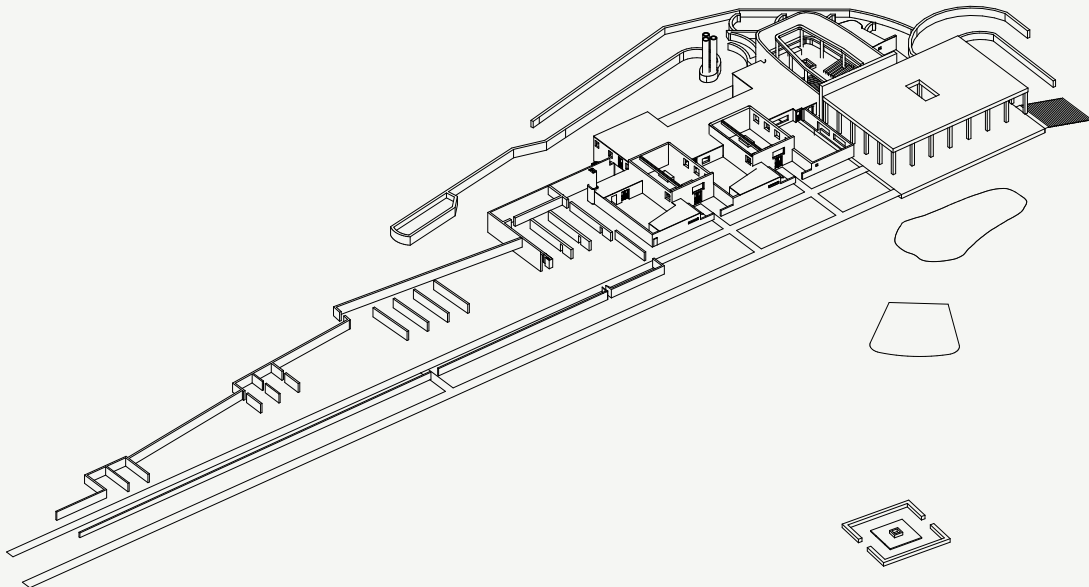
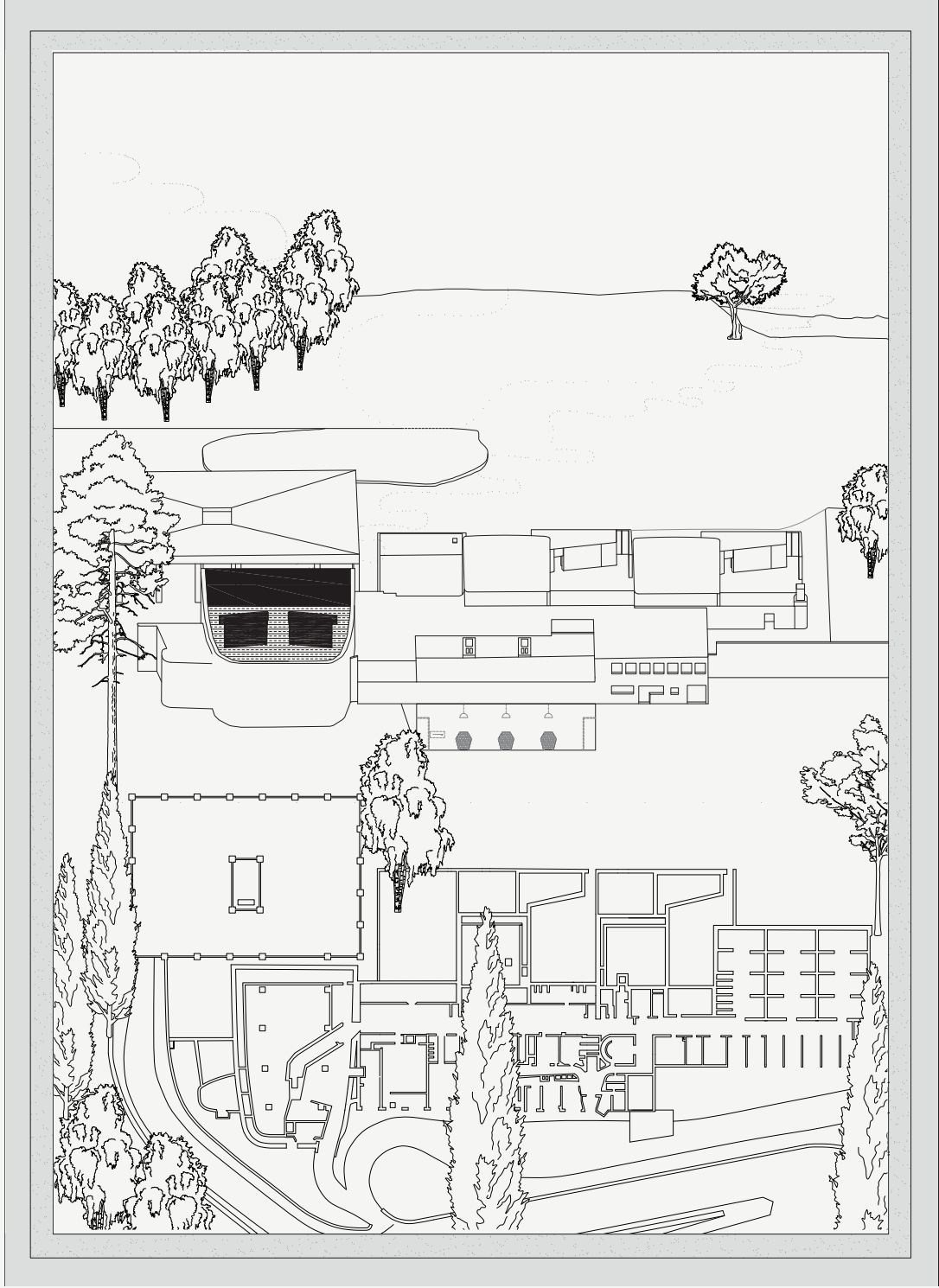



Figure 1.20 First Draft of the Essence Drawing, Woodland Crematorium



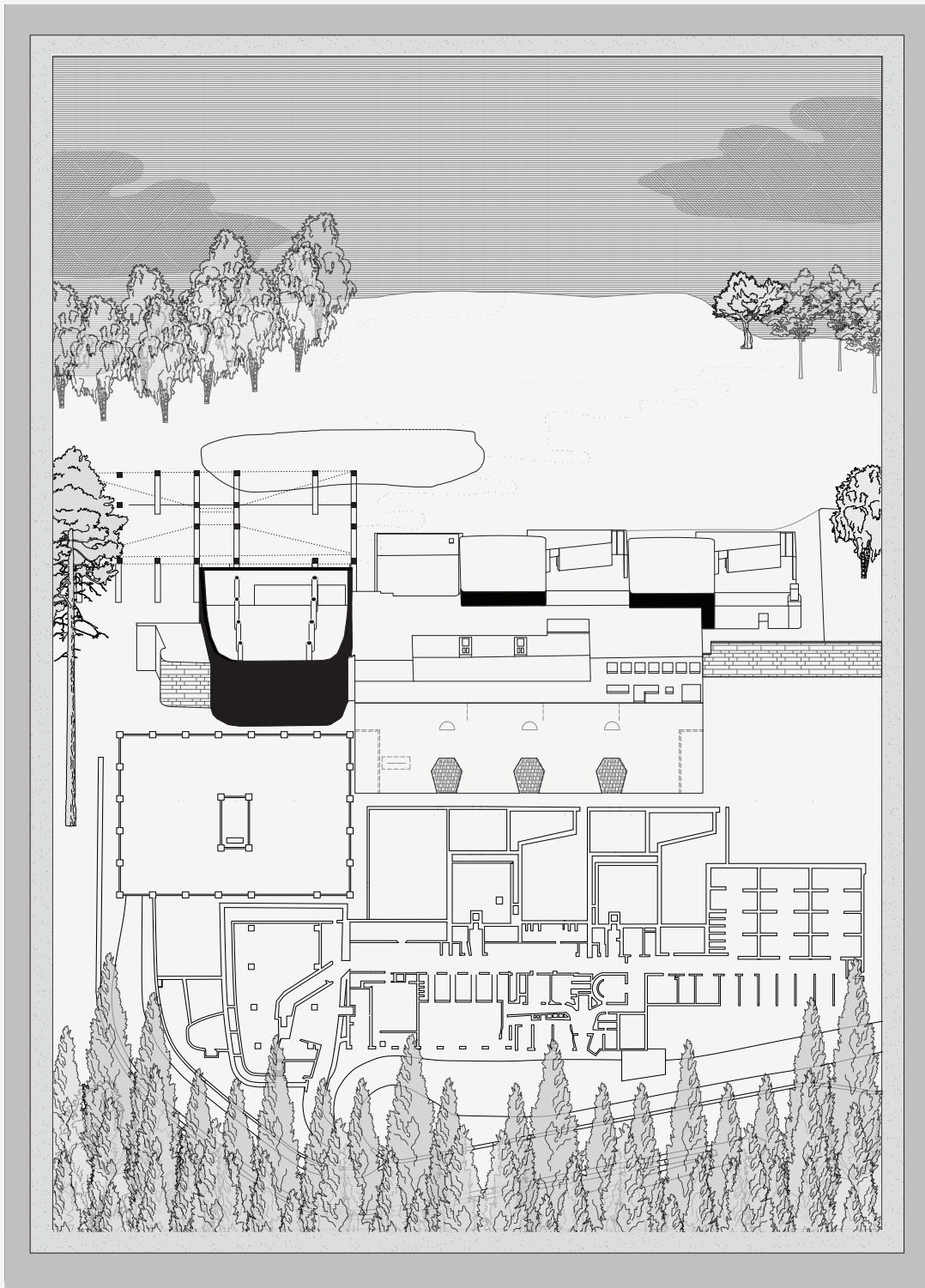

Figure 1.21 Process Image created as an option for representing the landscape of the Woodland Crematorium

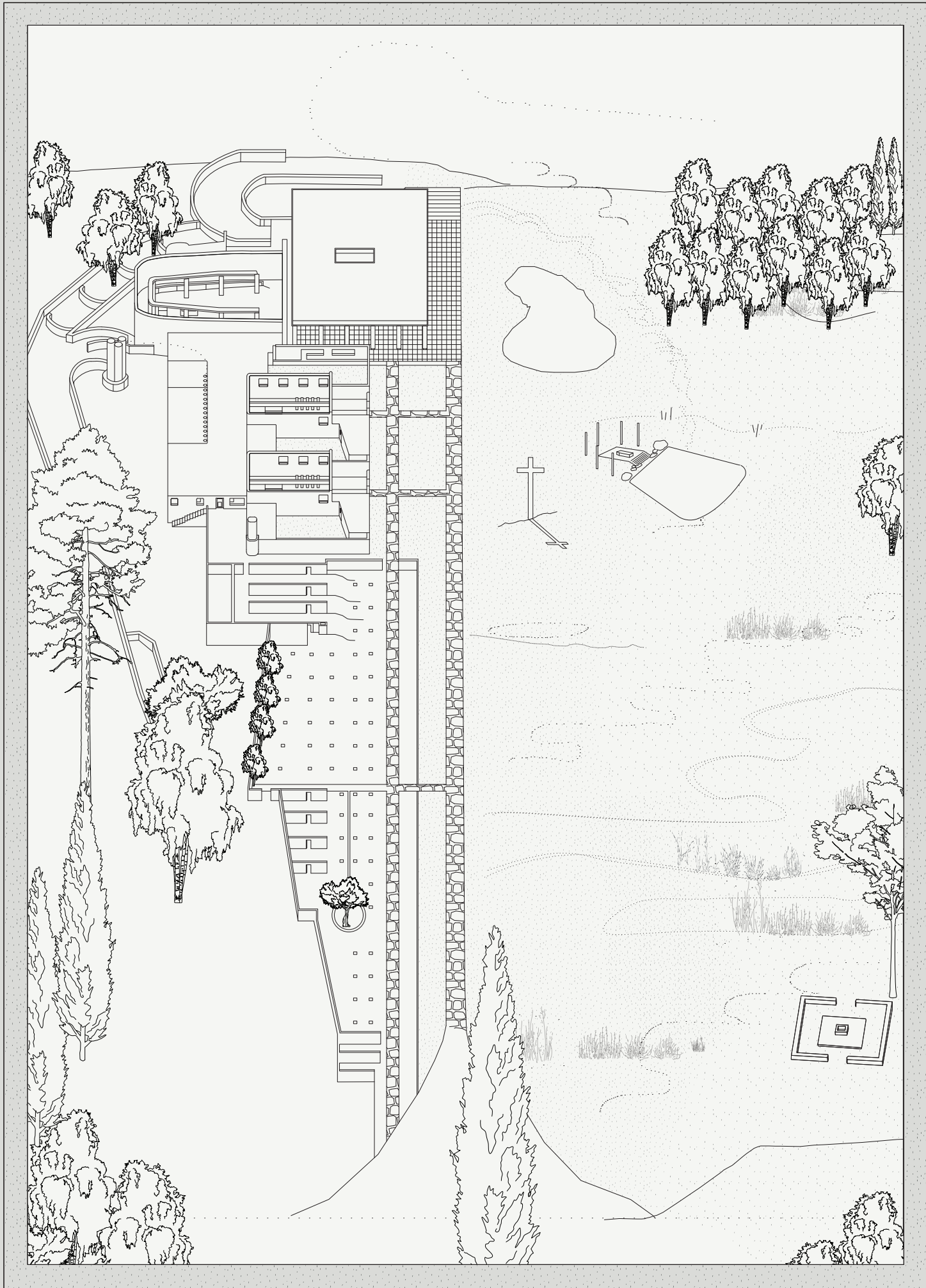

Figure 1.22 Final Essence Drawing, Woodland Crematorium



# Staatsbibliothek zu Berlin by Hans Scharoun

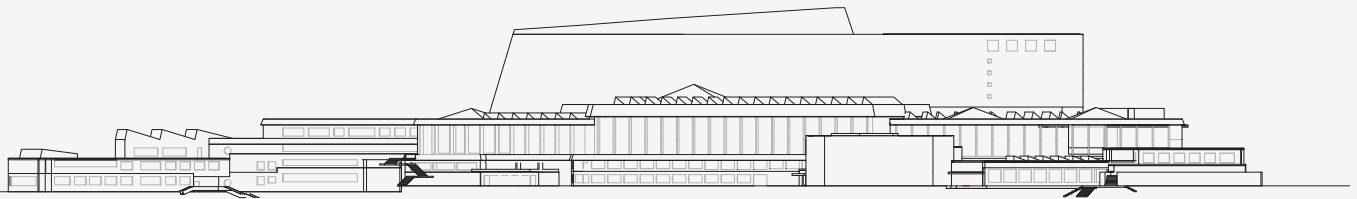

Figure 2.1 Berlin State Library, Hans Scharoun, Front Elevation



Figure 2.2 Main reading Hall indicating the mezzanine access

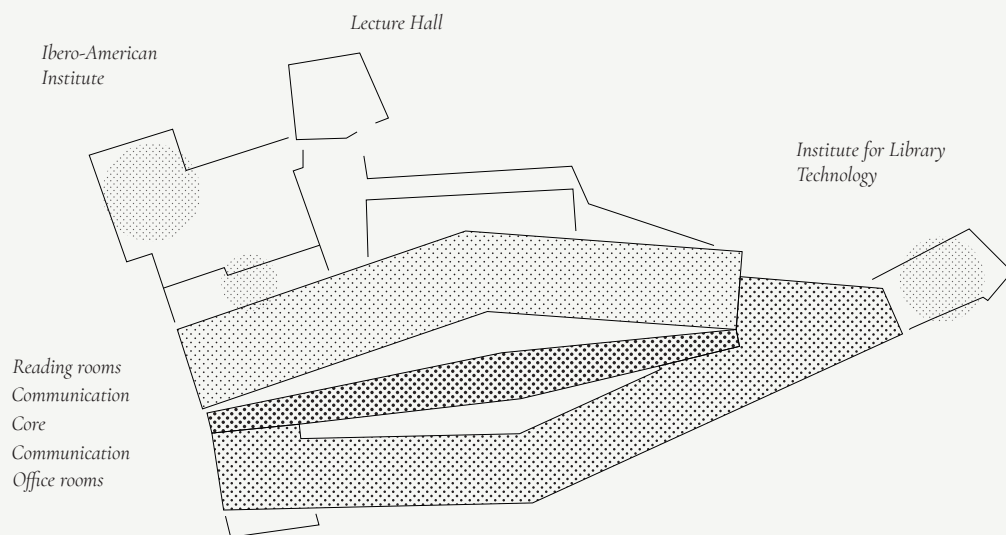

Figure 2.3 Zoning of the Building; Key areas



Figure 2.4 Main reading hall, Berlin State Library

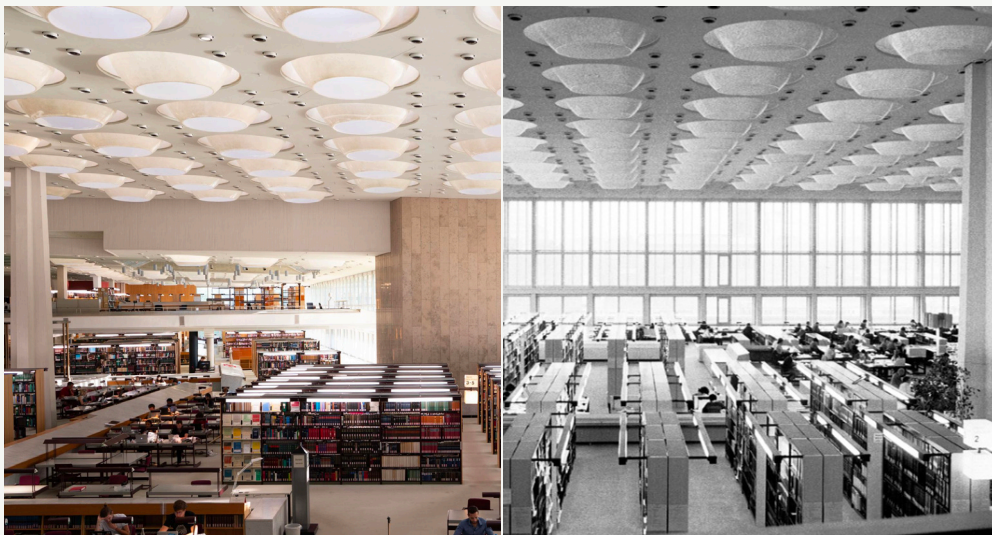

Figure 2.5 Perspectives and layout of shelves



Figure sequence 2.6 Exterior photographs of the Library.



Figure 2.7 Main entrance and staircase



## The Berlin State Library by Hans Scharoun

### *Collective investigation response*

One of the prolific examples of 20th-century modernist public buildings - the Berlin State Library designed by Hans Scharoun in 1963 is one of the several impressive public buildings in the Tiergarten district as part of Berlin's Kulturforum. Originally it was a representation of a spiritual band that would run from East to West Germany and house all major cultural and administrative sectors, but it quickly grew into a political manifesto as the competition between Eastern and Western city planners grew in the city. After winning the competition Scharoun had the opportunity to implement his ideas of the Kulturforum as an urban landscape. The large scale and the positioning of the project already implied some ideas of United Berlin. Scharoun used his architectural design to show the refusal of the status quo<sup>1</sup>.

The library was intended to complete the east side of Kulturforum and set the hard boundary between the urban plan and the projected motorway. The east side of the building works as a shield to the new expressway by positioning closed support spaces, storage and closed racks towards it. In addition, the scale of the horizontal bulky facade is designed to be conceived from a moving car and even then, to be an impressive and remarkable landmark<sup>2</sup> (Figure 2.6). On the east side, the building responded to the rest of the urban landscape by positioning the reading rooms and other annexes as a step down towards the open ground of the Forum. However, the reading rooms pick up the cubic form of the Mies's Nationalgalerie, while the terracing of the massing refers to the forum creating what Scharoun referred to as 'Vally'<sup>3</sup> (Figure 2.8).

Besides the library's internal functions, the building complex supplies space for the Ibero-American Institute, a large lecture hall and school for Librarians and the Institute of Library Technologies (Figure 2.3). Each function almost developing as a separate unit with its own entrance and internal courtyards for daylight. However, there is a large emphasis put on spatial experience as the library is highly differentiated in a manner that never becomes overwhelming or claustrophobic. The "path of the visitor" referred to by Scharoun illustrates the guiding principle of guiding visitors from one space to another in manners that never feel imposed but as a sequence of events that gently guides the person from the entrance hall up to the large reading rooms on to individual study/reading spaces<sup>4</sup>.

1 J. Christoph Burkle, Hans Scharoun (Studio Paperback, 1993), 136.

2 Peter Blundell Jones, Hans Scharoun (Phaidon Inc Ltd, 2002), 200.

3 Jones, Hans Scharoun, 201.

4 Ludwig Reichert, Festgabe zur Eröffnung des Neubaus in Berlin (Wiesbaden, 1978), 179.

5 Jones, Hans Scharoun, 203-204.

6 Burkle, Hans Scharoun, 137.

The interior of the main reading hall creates a unique feeling of spatial landscape with large platforms stepping up creating new spaces that still refer to the users and all the functional requirements of the library (Figure ). This creates a sense of intimacy within the functions that are inserted in organic continuous open space, covered by sun-screened ceilings that bring daylight referred to by Scharoun as a 'Skyscape'<sup>5</sup>.

Scharoun's works often offer the idea of subjectivity or individuality of human nature<sup>6</sup> considering the human scale and the atmospheric relation to the user. The project does not try to prescribe or replicate other architectural languages but tries to ground itself in its own time and place. By doing so the projects become easily interpreted by their users and not appropriated by political or power structures.



Figure 2.8 Ground Floor Building Plan of the Library

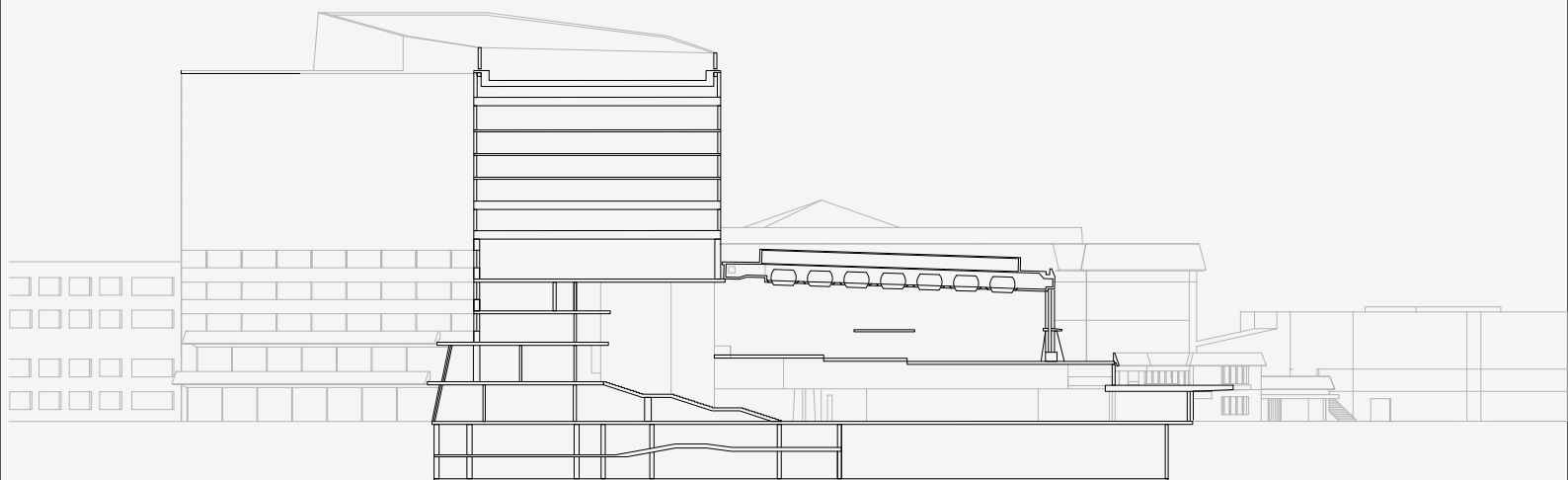

*Building Section aa'*



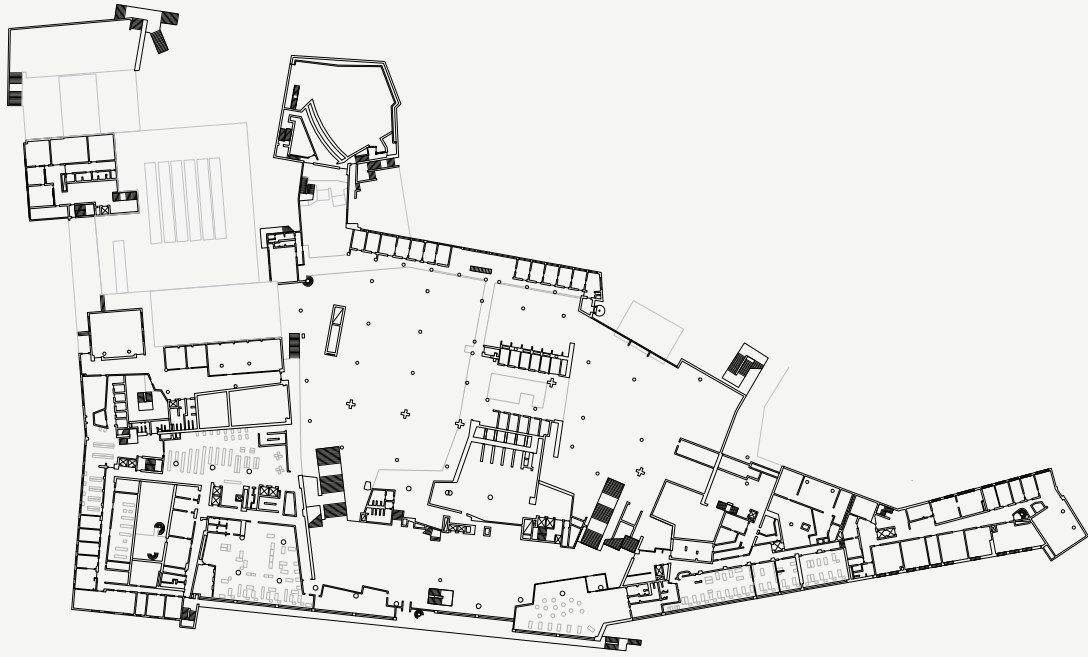

Figure 2.9 Floor Plan of the Upper Levels (1)

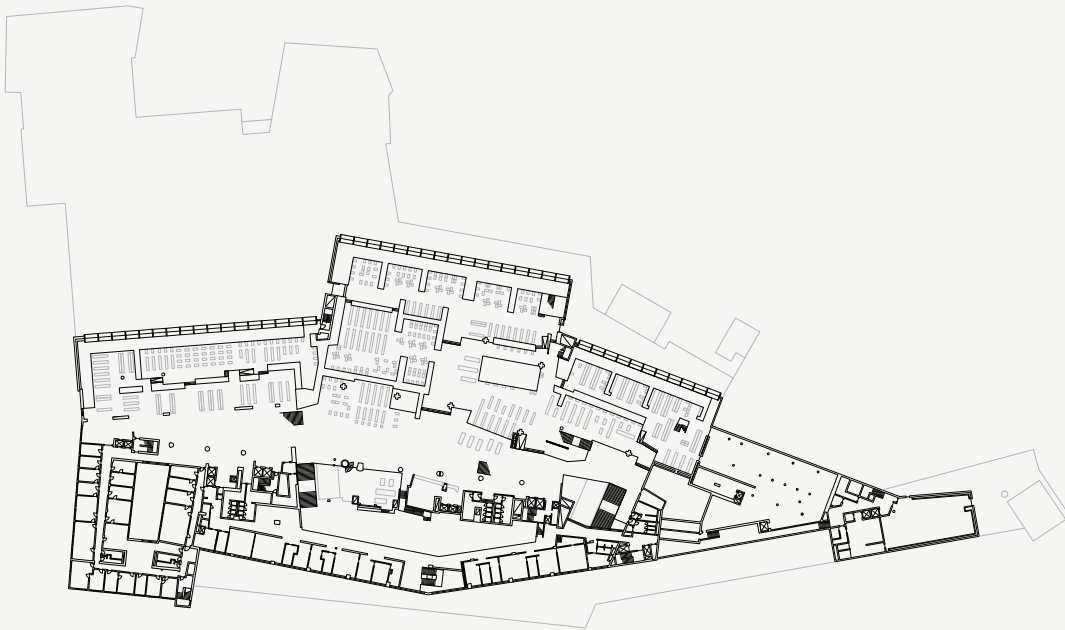

Figure 2.10 Floor Plan of the Upper Levels (2)



Figures sequence 2.11 Scenes from Wim Wenders 'Der Himmel über Berlin' showing how the library accommodates, shelters, and nurtures its readers in its vastness.

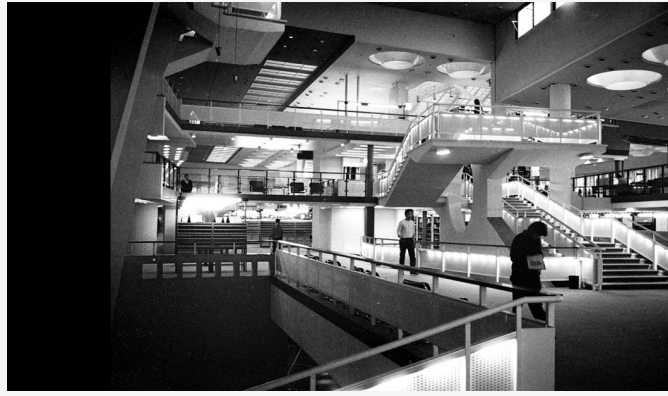
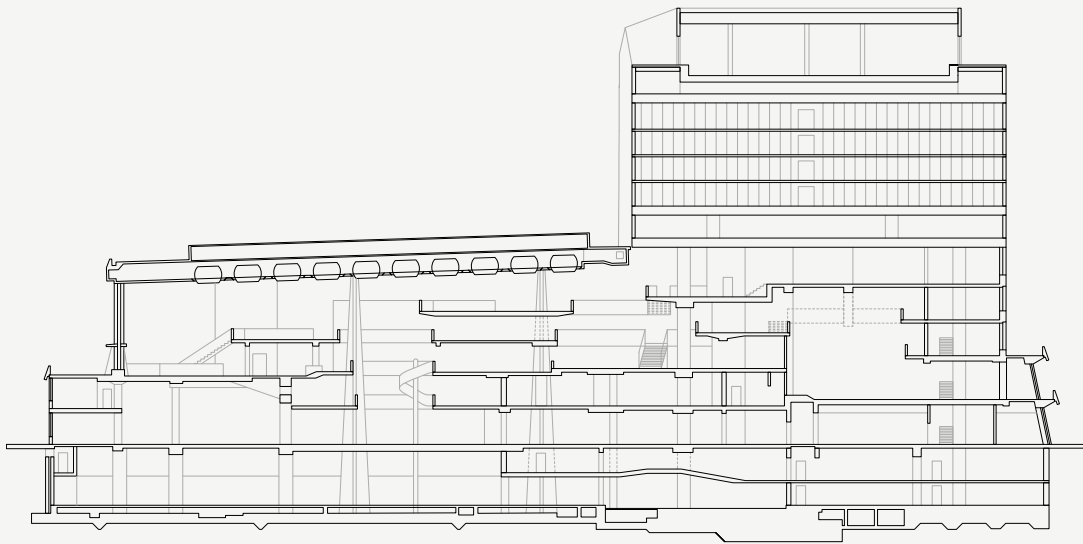

Figure sequence 2.12 Areas as used by the general public



*Figure 2.13 Building Section bb'*





Figure sequence 2.14 Occurance of Art and Ornamentation through interior glazing and panels.



Figure 2.15 Details such as the light fixtures serve as characteristic ornaments in space.



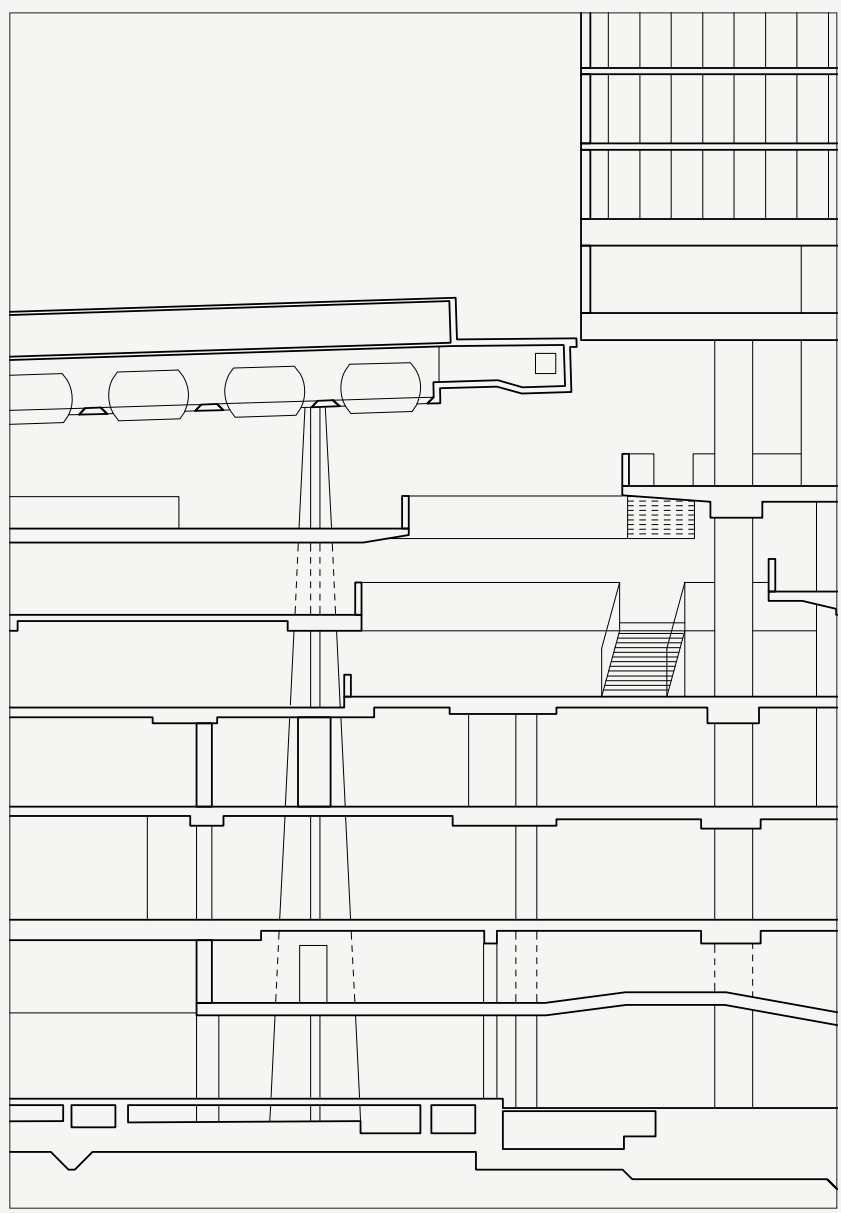

Figure 2.16 Interior Section indicating relations across levels.



Figure 2.16 Internal view, Berlin Library, photographer Daniele Ronca



# Bibliography

## **Berlin State Library**

1. Blundell Jones, Peter. *Hans Scharoun*. Phaidon Inc Ltd, 2002.
2. Burkle, Christopher J. *Hans Scharoun*. Studio Paperback, 1993.
3. Reichert, Ludwig. Festgabe zur Eröffnung des Neubaus in Berlin. Wiesbaden, 1978.

## **Woodland Crematorium**

4. Wrede, Stuart. The Architecture of Erik Gunnar Asplund. MIT Press eBooks, 1980. <https://doi.org/10.7551/mitpress/1328.001.0001>.
5. Woollen, Mary. Erik Gunnar Asplund: Landscapes and Buildings. Routledge, 2018.

## **Image References:**

1. Liffner, Andy, photographer. Photograph. Stockholm, Sweden. <https://www.andyliffner.com/>
2. Daniele Ronca, photographer. Photograph. Berlin, Germany. <https://divisare.com/authors/2144742707-daniele-ronca>
3. Torra, Joseph Maria, photographer. Photograph. Berlin. <https://www.flickr.com/photos/jmtp/albums/72157603838427773>

**Research Plan, Group 3**

Julia Palega  
Janis Klivlinieks  
Snigdha Ray  
Sora Kaito

Interiors Buildings Cities  
Msc. 3/4, TU Delft 2023