

A Typology of Shops to Transform into Housing

A Typology of Shops to Transform into Housing

A Typology of Shops to Transform into Housing

A Typology of Shops to Transform into Housing

CONTENT

9	Introduction
11	Background
13	Objectives
15	Methodology
17	Typology
19	INNER CITY
22	Historic
32	Revolutiebouw
40	Amsterdamse School
48	Post-War
56	Neighbourhood
63	SHOPPING COMPLEX
66	Shop Centre
78	Department Store
85	RETAIL ZONE
88	Small Size
96	Big Size
101	ADD-ONS
115	Conclusion
117	Outlook

INTRODUCTION

Retail spaces are left empty all over the country. At the same time, there is a pressing housing shortage that needs solutions in the short term. Transformation of shops into housing can be a partial solution, but the assignment is not one-fold: there are various shops, and every case is unique. Looking from an architectural perspective, however, one recognises some similarities.

The research explores these similarities and differences between shops with a typology that answers the question: *“What different types of shops can be recognised when considering a transformation into housing?”*



empty shops



housing shortage

BACKGROUND

This research reacts to two trends that are currently visible in The Netherlands: the housing shortage, and the large amount of shop spaces (retail) left empty.

Not enough new houses are being built, average house purchase prices rocketed, and the amount of homeless people has doubled in the past ten years¹. Over the course of this research, the crisis became only more clear: *woonprotesten* ('living protest') were held in almost every Dutch city², and a new minister was assigned specifically to deal with the housing problem. Last week (on March 11) the government presented two documents that focus on solving the issue: *The National Housing- and Construction agenda*, and *The Residential Building Agenda*³.

One of the proposed solutions is the transformation of 15.000 empty offices and shop buildings. When I started this project in September, the urgency and potential of transforming shops into houses was not yet as recognised as it is now: there were mainly (local) newspapers⁴ and real estate websites⁵ reporting on it. The urgency of transforming shops into housing has since become part of 'common knowledge' and national policy. I will therefore not elaborate any further on this.

For more background information, I recommend reading the article 'In een winkelcentrum kun je ook wonen.' ('you could also live in a shopping centre') that appeared in the newspaper NRC last December⁶.

1. Mark Hendriks, 'Dossier Crisis in de Woningbouw', in: *De Blauwe Kamer* 2021, no. 2, p.35-41

2. [woonprotest.nl](https://www.woonprotest.nl)

3. <https://www.rijksoverheid.nl/documenten/rapporten/2022/03/11/nationale-woon-en-bouwagenda>,

<https://www.rijksoverheid.nl/documenten/rapporten/2022/03/11/programma-woningbouw>

4. <https://www.volkskrant.nl/economie/wonen-in-een-omgebouwd-winkelpand-dat-levert-6-500-huizen-op-denkt-de-nvm>

5. <https://www.vastgoedmarkt.nl/retail/nieuws/2021/09/winkeltransformatie-dit-zijn-de-grootste-belemmeringen-101167759>

6. <https://www.nrc.nl/nieuws/2021/12/17/in-een-winkelcentrum-kun-je-ook-wonen-a4069428>

OBJECTIVES

This booklet gives an answer to the question “*What different types of shops can be recognised when considering a transformation into housing?*” by introducing a typology of shops, divided by their transformation potential. Some chances, challenges and solutions are shown in text and image for every type of shop, and the main considerations when facing these kinds of transformation assignments are set out from the perspective of an architect*. In short, this is a toolbox for designers and a very compact textbook for policy makers.

Many others before me have urged the importance of transformation, re-use, restoration and conservation for historical, environmental, cultural, social or spiritual reasons. However, some elements are neglected, or are just not mentioned in the same conversation. Why not talk about heritage and sustainability and social structures at the same time? Some structures are protected by (inter)national law, while others are demolished; wasted; thrown away; erased, without there being any discussion at all. Even if this practice is known to be harmful for our planet. Even if transformation of the existing can partially solve the pressing housing shortage of today, potentially on a much shorter term than newbuilds could possibly be realised in this country.

The problematique of empty shops has been on the public agenda since the financial crisis of 2007. However, no significant policy changes have been made until last week⁷. And when talking about shops, only some shops are implied: the ones on main shopping streets or complete shopping centres. Shops on the outskirts of cities, often very large in surface, are not mentioned at all: they just get demolished. One of the main reasons why transformation of shops into housing is relevant, is because it allows for densification of the already urbanised areas, instead of building in ‘the green’.

I want to broaden the conversation about transformation by including the shops on the outskirts of cities, but I also hope to ignite a more indepth theoretical discussion by showcasing the problematique and potential with a case-study. Therefore, I will develop the first type of group 3, ‘*Retail Zone - Small Structure*’ into a design project. With this booklet and the adjacent case-study, I hope to inspire beyond the scope of my specific research question, into the larger field of circularity and preservation of material and immaterial means and values.

* Many aspects determine the possibility and viability of a transformation, such as policy, ownership, building regulation and much more. This research only considers the architectural aspects.

7. <https://nos.nl/artikel/2420767-kabinet-komt-met-nationaal-bouwplan-vanaf-2024-100-000-woningen-extra>

METHODOLOGY

The developed typology is applicable in the entire country of The Netherlands, but the geographical area for the research is narrowed down to the city of Amsterdam in order to keep things manageable, because of the large variety of shops and the relatively large amount of data available. To develop and order the types, two complementing methods were used parallel to each other: *categorisation* and *definition*. The main input is (municipality) maps, google photos, google maps and field research (for technical and structural information).

Categorisation started by researching and ordering the 150 main shopping areas as recognised by the municipality of Amsterdam⁸. I compiled a list of 'possibly defining characteristics' and started trying to order all areas along these.

For the *definition*, I sketched different types based on intuition and observation: defining differences by heart, by knowledge of the city and country; by 'have-seen'. A more tangible approach, with text and image, focussing on instantly recognisable qualities that define transformation potential.

By filtering out, rearranging and combining types multiples using these two methods combined, the total was eventually narrowed down to a total of nine types subdivided among three groups. For all types, I developed an overview of chances and challenges, more or less elaborate depending on the type. This lead to an overall conclusion of which types of shops are more- or less suited for transformation and why.

This project is practice-based (not literature based). Most of the input and data was retrieved from fieldwork, whether it being online (maps and datasets) or on-site. The way of conducting research is strongly supported by general technical, architectural and societal knowledge obtained during studying at the TU and keeping track of news and media through the years. Information and data about vacancy, transformation and demolition (sustainability) were retrieved from several research institutes and governmental websites. Much of this project is based on 'common sense' and 'general knowledge': especially the environmental aspect, which is one of the pillars that makes the topic of transformation relevant.

⁸ <https://maps.amsterdam.nl/markten/>

TYOLOGY

The purpose of the typology is to clarify what are the main considerations when transforming a shop into housing.

There are three groups or 'families' of shops: *Inner City*, *Shopping Complex* and *Retail Zone*. The types in every family are related: they share some important characteristics. Next the groups and types, there are a number of *Add-Ons*: these are relevant qualities that are typical for shops, that are independent of a specific type or type group.

For those consulting this typology as a textbook, the total of all types illustrates the scope of transformation potential. There is no hierarchy, so types can be studied at random: one can start reading at any page.

As a toolbox or guide for a particular transformation assignment, the typology should be read as a menu. The different types are divided based on what sets them apart from each other. In practice, a shop or group of shops can have qualities of several different types at once.

INNER CITY

INNER CITY

Inner City are independent shops typically found in the centre of a city, town or neighbourhood. One building generally means one shop, located on the ground floor. If there are floors (in use) above, they are generally used for housing.

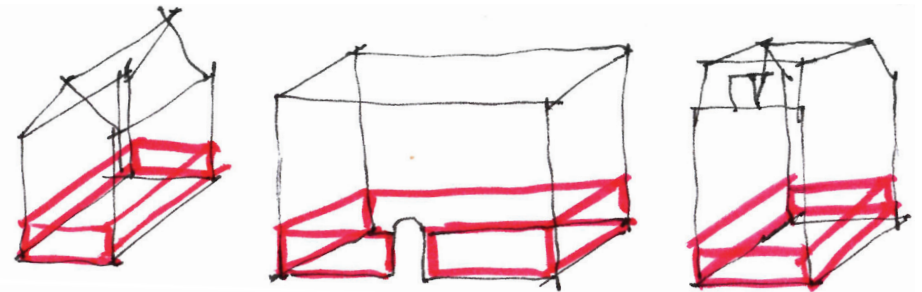



Haarlemmerdijk, **Amsterdam Centrum** (bron: funda.nl)

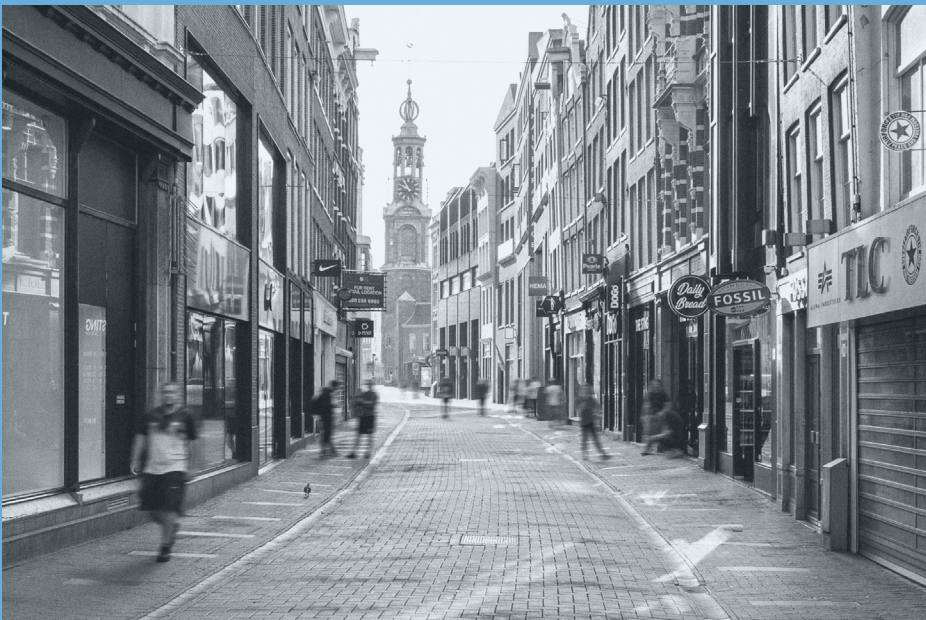

Kalverstraat, **Amsterdam Centrum** (bron: funda.nl)

HISTORIC

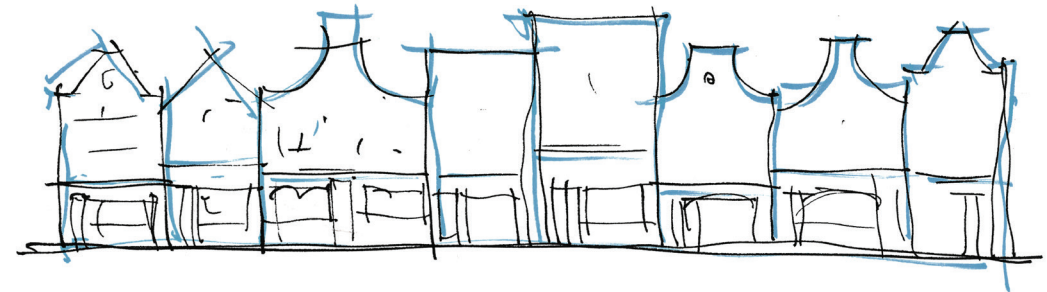

This shop is found in the historically grown city: situated on the ground floor of a building that is unique, or different from at least 90% of the other buildings in the street. Low-rise, often constructed before modern times, with masonry walls and timber floors and roof structures (or concrete, if erected after the 1950's). Originally, there would be two separate entrances on the plinth: one giving access to the shop, the other leading to living spaces of higher floors.

The shop space is long in proportion to its width, with windows on one or two of the short ends. Ceilings are low to average in height (typically around 2,5 - 3,5 metres).

Most of these shops face multi-use streets (car, bike, public transport, pedestrians), while some of the most crowded and centrally located streets are restricted to pedestrians during the opening hours of shops. Access to the upper floors is sometimes removed completely in order to maximise the width of the shop front. This leaves the other floors vacant.

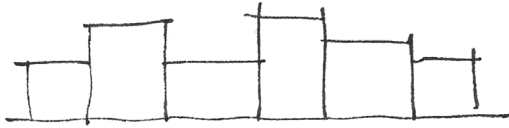

Shops of this type vary in size, style, material, building structure and more, but may share some typical characteristics depending on the location (just like any building would: e.g. brick work is a common building material in The Netherlands, as are steep roofs with red shingles).

There are always exceptions: what is typical for the type 'historic', is that every building is a unique, independent structure.

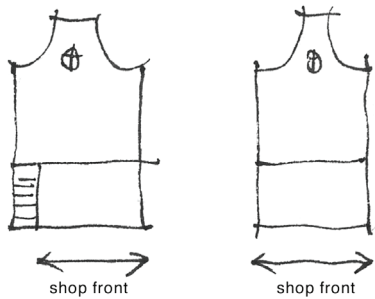

*Most typically, a shop is located on the ground floor, with an **extra door next to the shop front** in the plinth, giving access to offices or housing on the floors above.*

*In some cases, **the entire plinth is made shop front**, making it impossible to access the other floors without passing through the shop. As a result, **the other floors are often not used**.*

Access to these floors may in some cases be possible via the backside of the building, if there is (enough) free space and a route leading to the main road. In most cases this is difficult because of the irregular urban fabric.

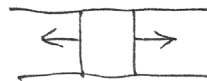

access via front and/or back side

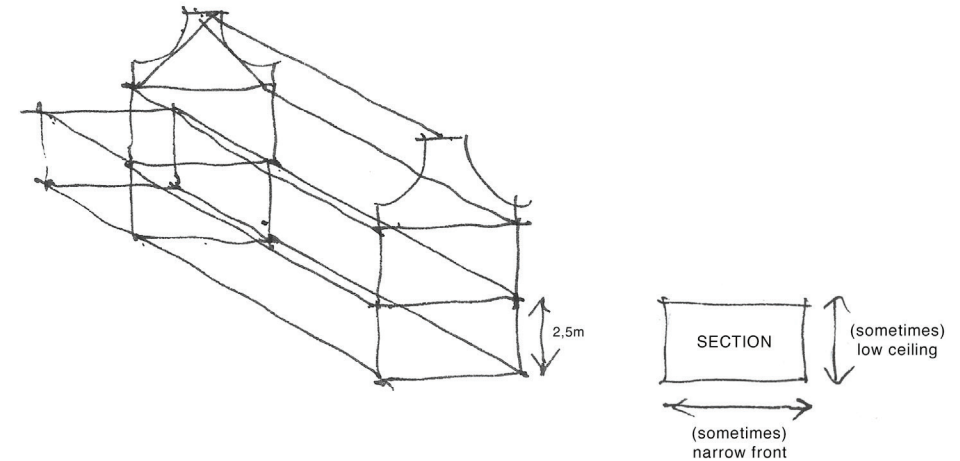

This is an example of a shop space on the Haarlemmerdijk in Amsterdam. The sizes are quite typical and common for shops, but problematic for housing.

*The original depth of 11 meters was extended to 18 meters by adding an extra space on the back. With a ceiling height of 2,5 meters and windows on only one side, **the space gets very little daylight, making it unfit as a living space.***

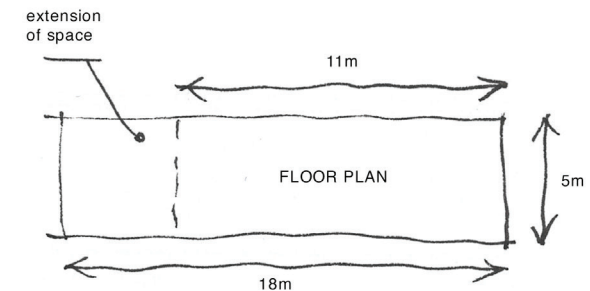



(a) location: Heiligeweg - Kalverstraat - Rokin

-  20 m
-  one shop of this type
-  shops of the same type
-  other buildings



(a)

Shops in the Kalverstraat. Only access from the street side, totally built-in between the neighbouring buildings on the other sides. The front access only allows entrance to the ground floor.



(b)

location: Haarlemmerdijk



20 m

one shop of this type

shops of the same type

other buildings

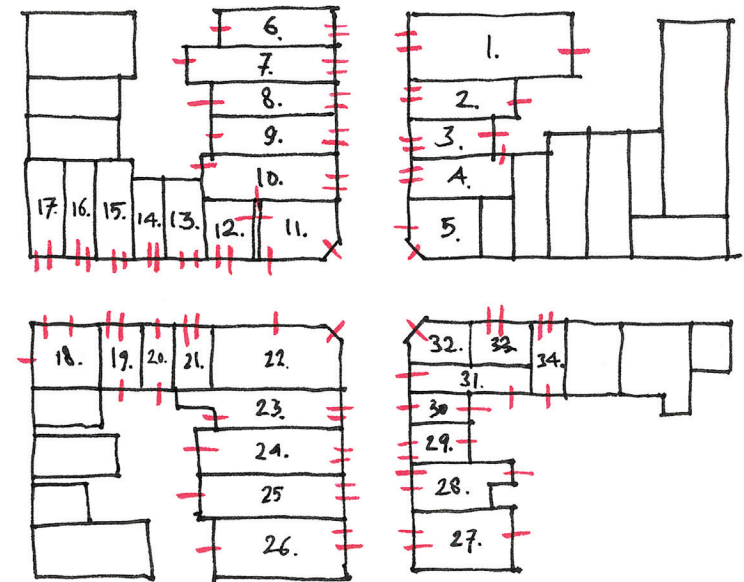

(b)

Shops on the Haarlemmerdijk. Most buildings have a double access on the street side (one for the shop, one for the floors above), and an access on the back leading to a garden or shared courtyard.

TRANSFORMATION POTENTIAL

These shops are often located in lively neighbourhoods that are very suited to live in: with other houses and a function-mix. The problem is often an inadequate accessibility or a lack of daylight, which limits the amount of possible organisations of the plan. It may be necessary to remove (added) parts of the building to allow for extra daylight.



Jan Pieter Heijestraat, **Amsterdam-West** (bron: funda)



Oostzaanstraat, **Amsterdam-West** (bron: funda)

REVOLUTIEBOUW



These shops are found on the ground floor of a building that was constructed as part of a larger development project, erected somewhere between the end of the 19th century and the 1930's. Although only buildings in the same row are exact copies, all these buildings and their shops are practically the same: the shop is part of the original design (a big-window shop front), access to shop and housing on the upper floor is separate. Buildings are identical to at least 10 of its neighbours. Materials are brick walls and timber floors. The building is always five stories high, with three windows on the three middle stories.

The ground floor ceiling is high, and the shop has a backyard, which can often be accessed via a second entranceway behind the garden. The entire shop space gets daylight. The entrance door of the shop is often placed in a little setback, creating a threshold between the shop and sidewalk.

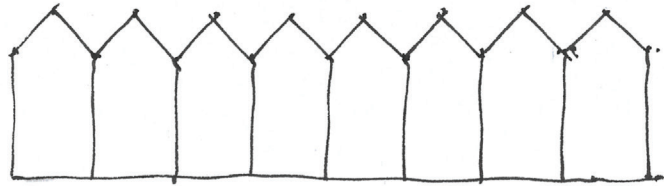

buildings in the same row are (almost) identical

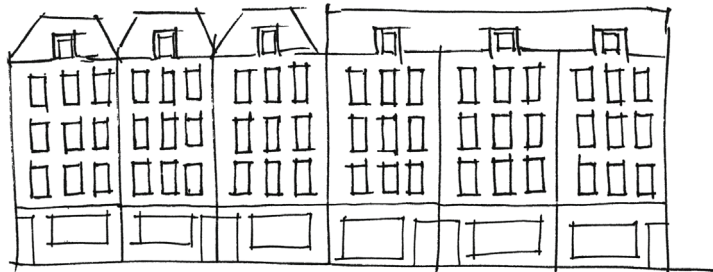

Some shops are exactly the same, other shops are almost exactly the same.

the entrance is a little bit set back

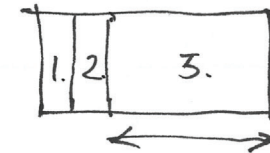
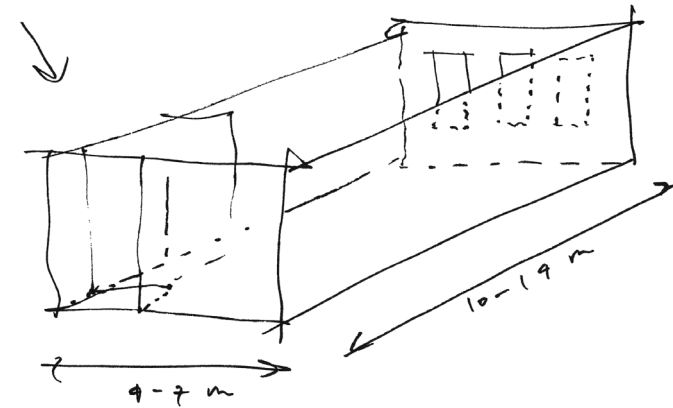

separate access to different parts of the building:



door 1. gives access to the upper floors, door 2. gives access to the shops, part 3. is the shop front (window)

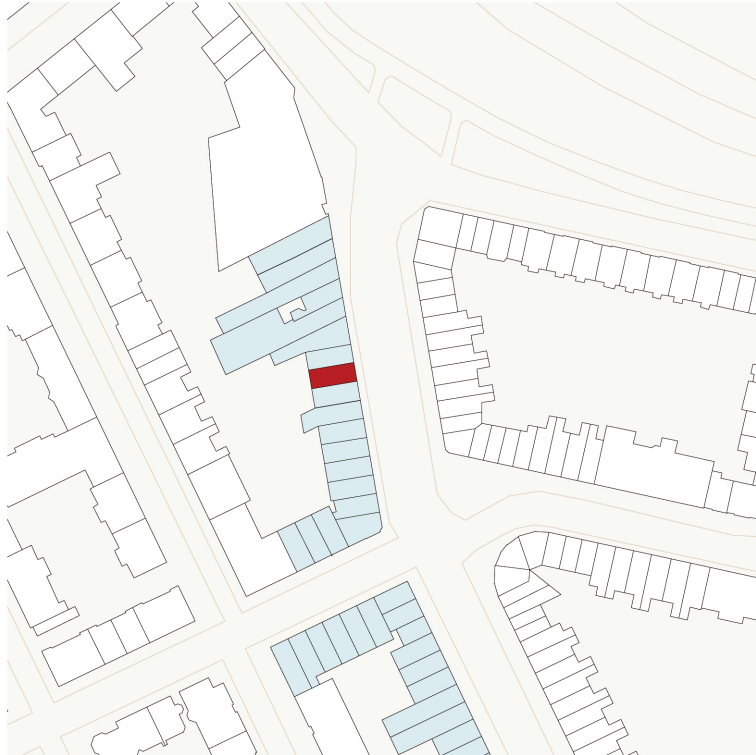

free space on the back: a garden that can be accessed from a communal alleyway inside the building block



location: Spaarndammerstraat

-  20 m
-  one shop of this type
-  shops of the same type
-  other buildings

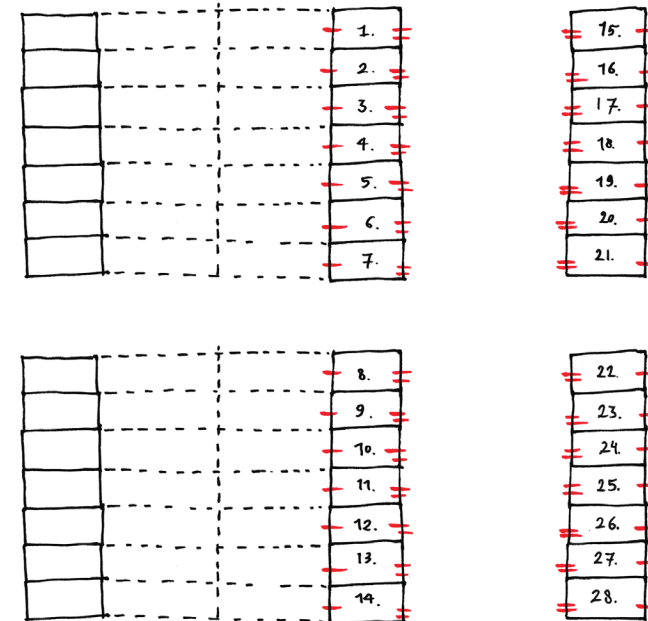

Shops have double access on the street side, and an access on the back that leads to the garden. The garden is often connected to an alley on the back that leads to the public road.

TRANSFORMATION POTENTIAL

Shops in revolutiebouw buildings are typically easy to transform into housing. There is a private access on both the street- and garden side. The high ceilings and large windows let enough daylight in.



Rijnstraat, Amsterdam-Zuid (bron: google maps)



Rijnstraat, Amsterdam-Zuid (bron: funda)

AMSTERDAMSE SCHOOL

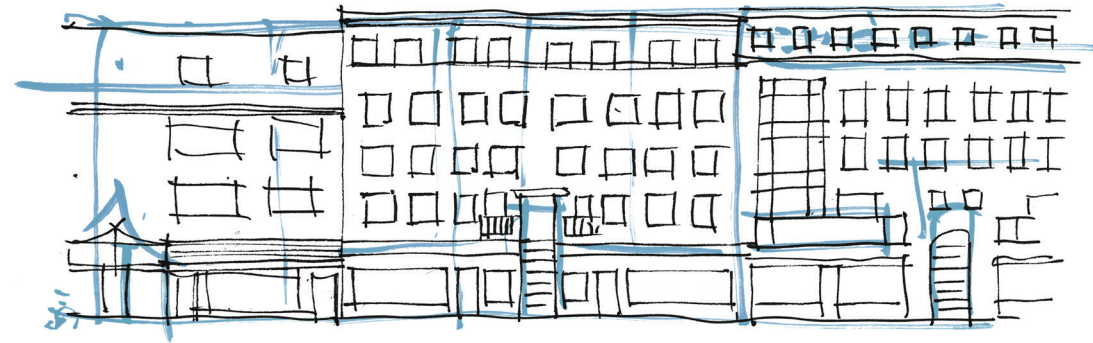

Although seemingly similar to 'Revolution Build', this is a type of its own. It can be found in big cities such as Amsterdam and Rotterdam, but never in villages and rarely in smaller cities.

The shop space is part of the original design. Access to the shop is completely separate from that of the houses on floors above, which can be reached via an open-air staircase - part of-, but on the outside of the building. This makes it practically impossible to remove the access to the higher floors - the shop front already covers the maximally possible width of the plinth.

Shop spaces are very exposed: a large glass shop front edges directly on the sidewalk, without any threshold if not covered. The sidewalk and street are broad and busy, street noise is typical here.

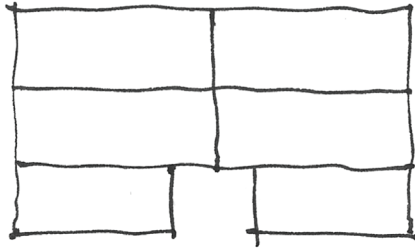

Spaces (shops and houses) are switched both horizontally and vertically, with a central external staircase leading to the front doors of the upper floors. All doors located on the ground floor level give direct access to spaces on the ground floor.

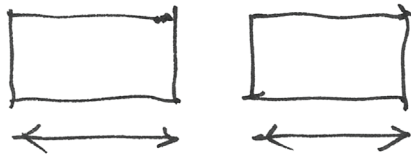

the shop front takes the entire width of the plinth of the spaces behind

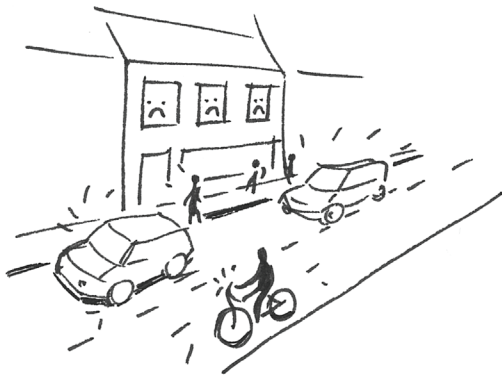

shops are always situated on broad, busy streets with broad pedestrian paths and multiple traffic lanes in both directions (tram, bicycle, car, bus), so there is **street noise** and **very little privacy**





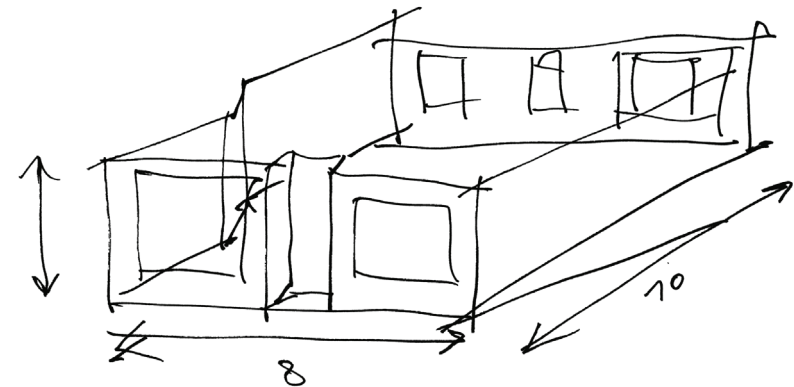

open air staircase gives access to the floors above



the ground floor is wide for its depth, allowing multiple possible organisations



location: Rijnstraat, Plan Zuid

-  20 m
-  one shop of this type
-  shops of the same type
-  other buildings

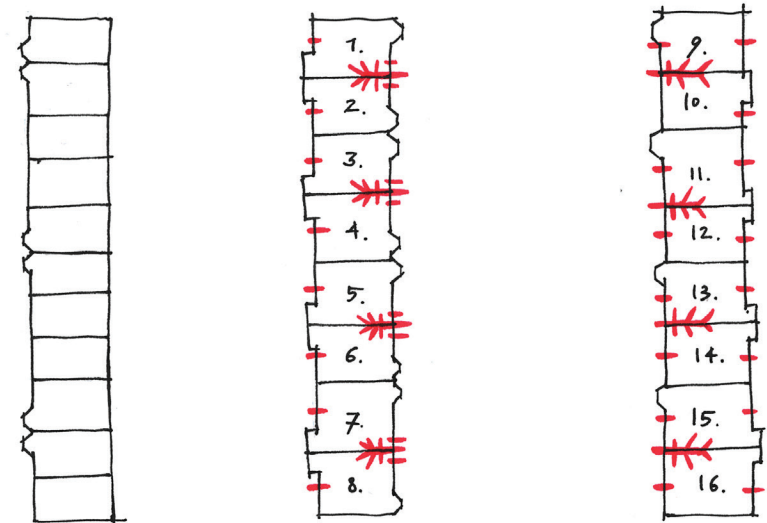

Multiple access ways on the front: one leading into the shop, and others via an outdoor staircase directly into the apartments. There is an extra access on the back side that leads to the garden.

TRANSFORMATION POTENTIAL

The shop space can easily be transformed into a house because of the generous sizes of the plan, but spaces facing the street have very little privacy and often suffer from street noise. This could be solve by creating a border (the sidewalks are very broad), such as a small garden on the front.



Mosveld, **Amsterdam-Noord** (bron: google maps)



Burgemeester de Vlugtlaan, **Amsterdam Nieuw-West** (bron: google maps)

POST-WAR



These shops are located on the ground floor of large building blocks that were erected after the second world war. The building itself can take many shapes, from low- to high rise and from mono- to multifunctional. The shop fronts span the entire width of the plinth. Shops can differ in size, either taking up the entire ground floor or only sections of it. Access to the upper floor is organised via centrally located entrances, either on specific parts of the front or via the back-side or core of the building.

Functions are not mixed, so the building parts intended for the use of a shop are focussed strongly on accommodating only that (and not housing). The plan can however be flexible, if the carrying structure is a concrete skeleton: the construction is often made with 'modern' materials such as glass, concrete, steel and plating. Insulation may be inadequate, and installations either obsolete or absent. Some shop spaces are very deep, with large surfaces reaching several metres behind the facade. A consequence is little direct sunlight.

There is little privacy because the border between inside (the shop space) and outside (the street or sidewalk) is very 'hard', the only threshold is a glass wall.

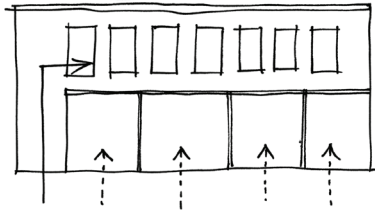

access to the above floors is organised in central points, sometimes on the inner core of the building (not facing the public street)



street with cars (and parking spots)

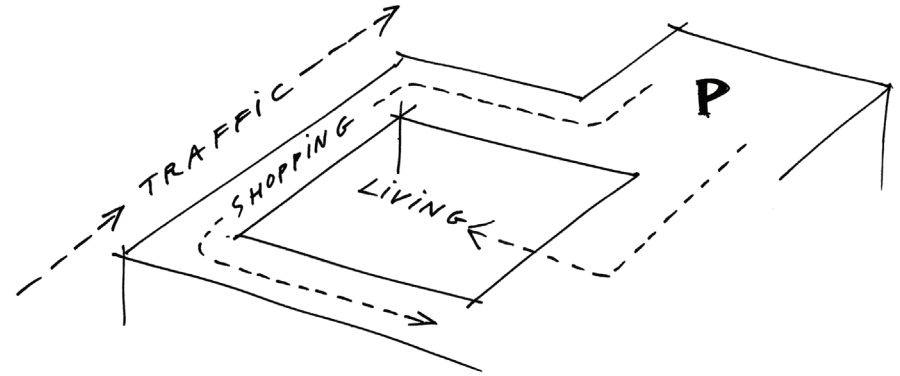

functions (transportation, retail, living) are organised separately and do not cross

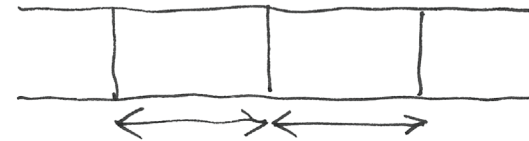

shop fronts cover the entire width of the (monofunctional) plinth

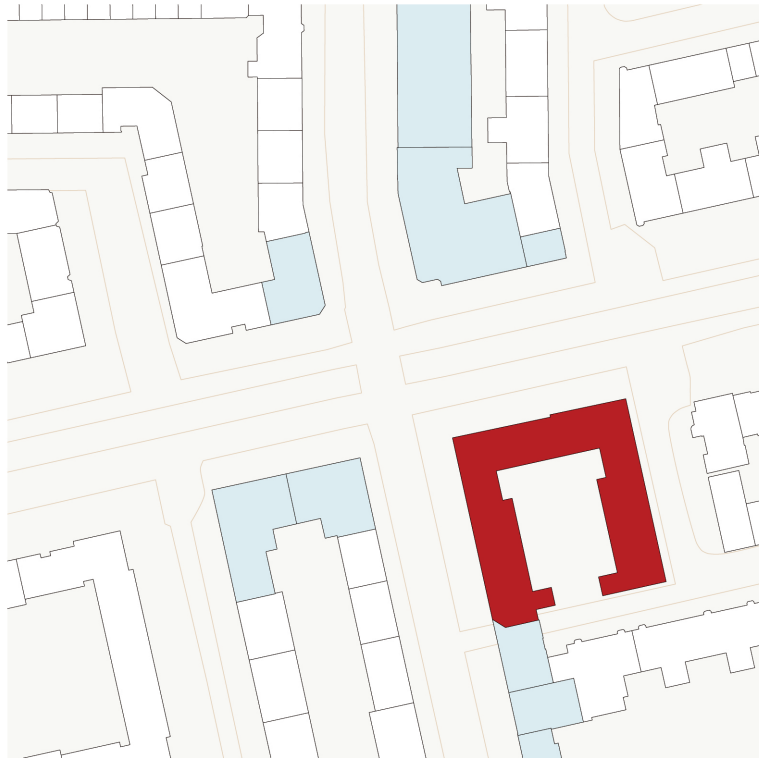

location: Indische buurt, kruising Molukkenstraat-Insulindeweg

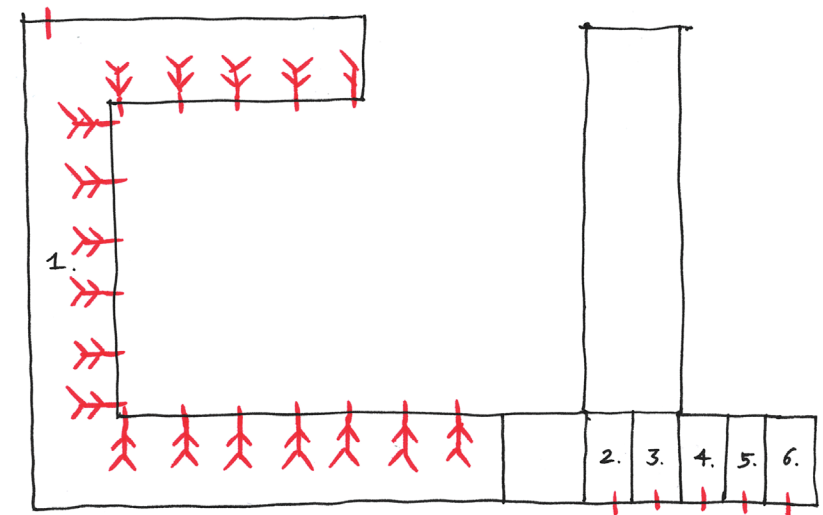
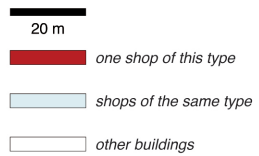

1. There is only one access into the large ground floor, from the street side. Access to the other floors is via a raised floor on the back/inside of the building.

2./3./4./5./6. Access from the street side only.

TRANSFORMATION POTENTIAL

The transformation potential is dependent on the specific situation: common problems may be a lack of privacy, facing a busy street, inadequate building construction (installations and insulation), the presence of asbestos and a lack of sunlight. A free floor plan can be a possible benefit, allowing for relatively easy rearrangement, and the opportunity to redevelop large blocks at once.



Mercuriusplein, **Amsterdam-Noord** (bron: stadsarchief)



Loosduinsekade, **Den Haag** (bron: google maps)

NEIGHBOURHOOD



This type of shop is often the only, or one of the only shops in a neighbourhood, providing for a level of function mix. Originally hosting a specialised function such as baker, butcher or greengrocer. The shop owner would live above the shop. Since the emergence of supermarkets, shops of this kind are rarely still found in their original shape and use, many were turned into houses.

The building style and period can vary between neighbourhoods, but the shops generally have similar characteristics: often located on a visible location, facing a small square or on a corner. The shop is often part of the original design of the building, setting it apart from the ground floors of adjacent buildings.

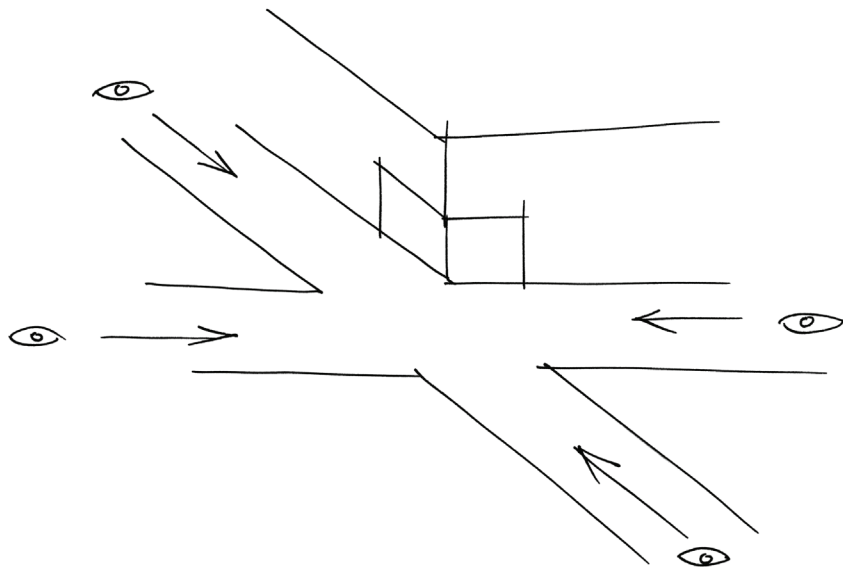

situated on *street corners and squares* for the best visibility

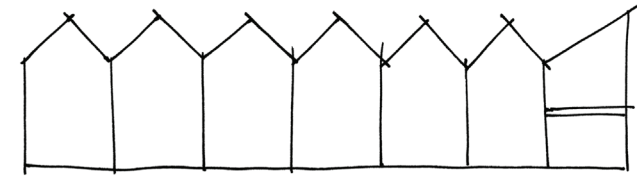

the only shop in a row of houses

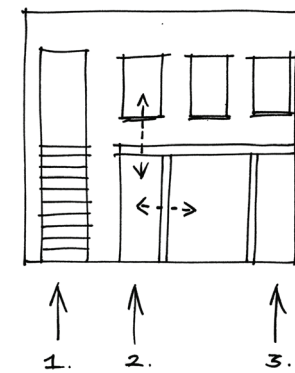

multiple access ways, and sometimes the shop is also connected to the upper apartment internally

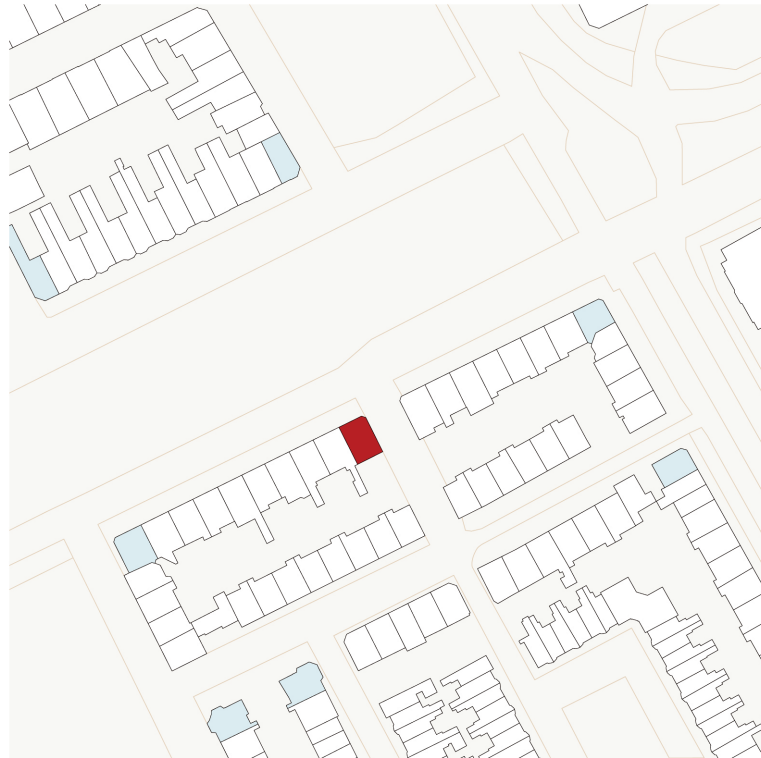

location: Rustenburg, Den Haag

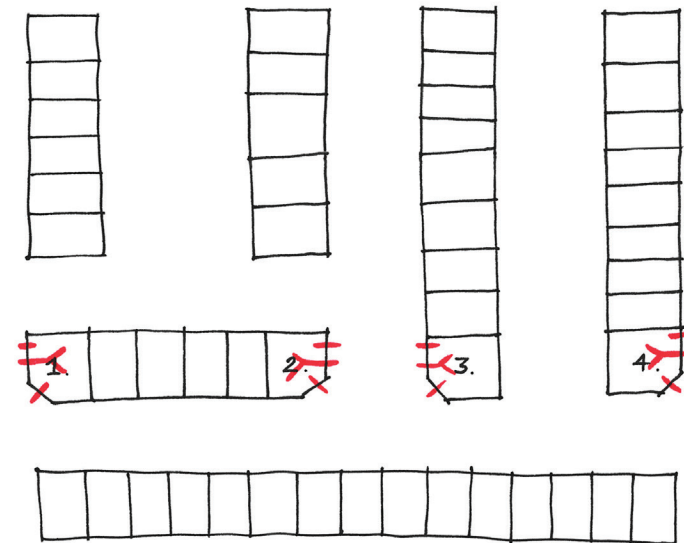
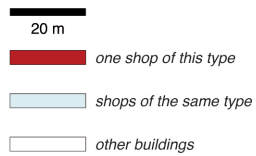

Neighbourhood shops are often located on corners. There is direct access to the shop from the street, sometimes a second access to the ground floor, and a separate access to the floors above.

TRANSFORMATION POTENTIAL

Transformation into housing is fairly easy, because the technical qualities and characteristics are the same as the neighbouring houses, and direct access is always possible. The shop may already be connected to the floors above.

However easy to transform, it is often preferable to preserve these types of shops because of the value they have for neighbourhoods, providing both liveliness and the nearby availability of goods.

SHOPPING COMPLEX

SHOPPING COMPLEX

Shopping Complex are groups of shops collected in one or more (connected) buildings. Some of these buildings function as the centre of neighbourhoods located on the outskirts of cities, but they can also be found in city centres or individually between cities. All shops are accessed through the same (often roofed, pedestrian-only) pathway. The building is generally mono-functional, or forms one large block in a multi-functional building complex.

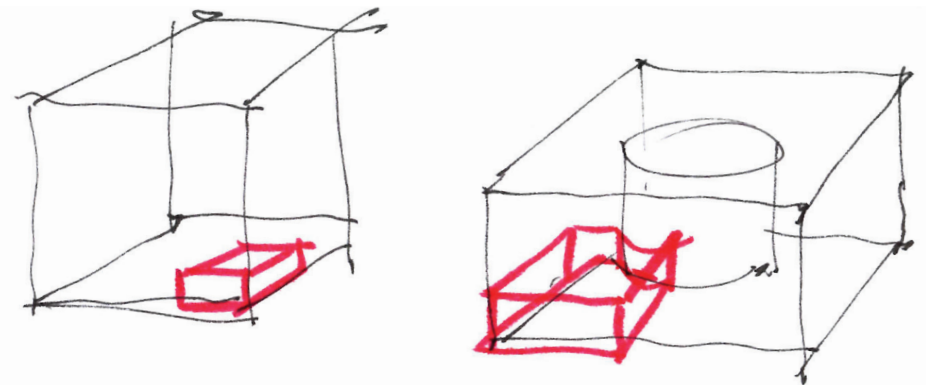

Bezaanijachtplein, **Amsterdam-Noord** (bron: funda)Diemerplein, **Diemen** (bron: Marketing Tribune)

SHOP CENTRE

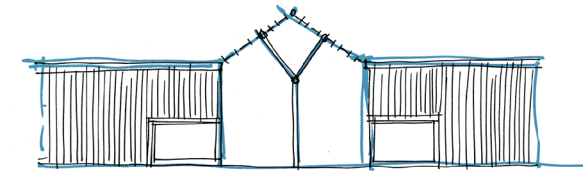

(a)

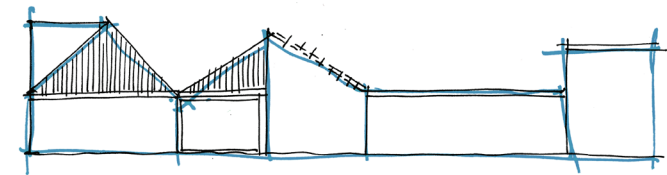

(b)

A shopping centre is what's typically implied with the Dutch term *winkelcentrum*. Most structures were erected after the war, from the 60s to the 90s, but they still get built to this day. Shopping centres are notorious for being left empty after only a few years of (not fully occupied) use.

In cities, they are located inside of building blocks, completely surrounded by other buildings, or they can function as the commercial centre of a post-war neighbourhood - independently, without other buildings attached. On the outskirts or in between cities, they may be completely detached from the built environment, but easily accessed by car. There is no function mix: only shops and supportive functions, such as parking space. Sometimes the structure is attached to other functions, but the shops still form a clustered group.

Multiple shop spaces are collected in one structure. This can either be in a single structure with an open core or a covered hallway, or several structures connected by a transparent roof. If the building construction (materials, measurements) is the same for the entire structure, every shop is constructed according to the same principles. If some parts were added later, there may be more variation between shops in the same complex.

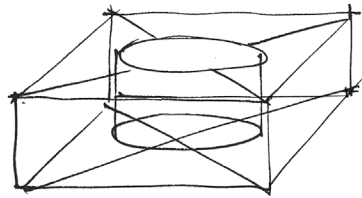

all shops in the same supporting structure

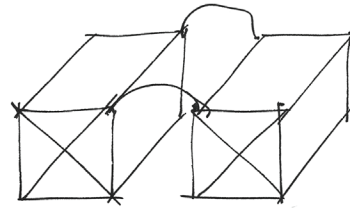

two supporting structures connected by a roof structure

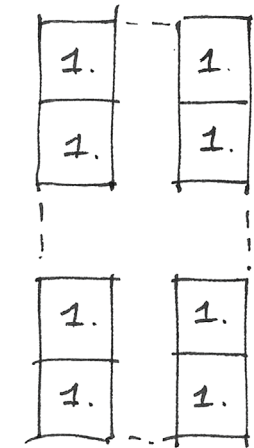

all shops/spaces are identical

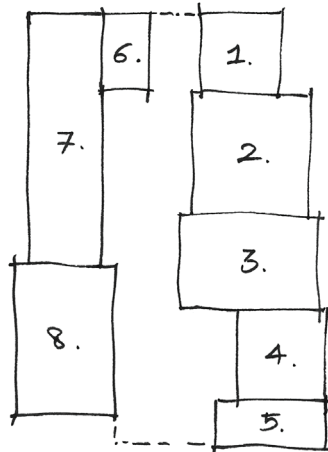

shops/spaces are different in size

All shops are accessed from a pedestrian-only covered hallway. This hallway can take different shapes, such as a cross, or with a (covered) open core in the middle.

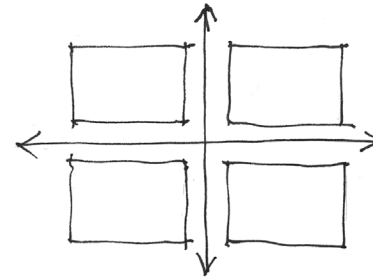

orthogonal route

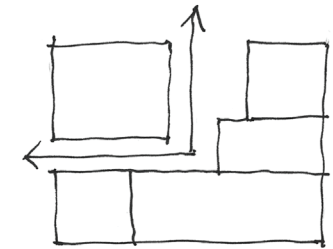

divergent route

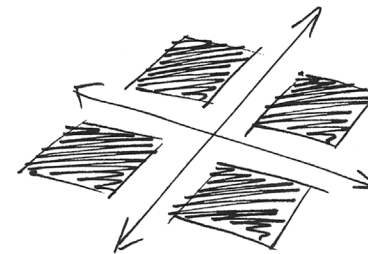

cross routes

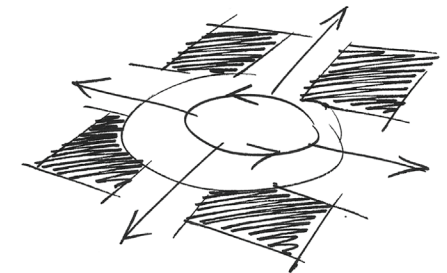

open (light) core

The amount of shops can vary, up to several tens. There are typically one or two storeys, but there can be more. The different storeys are connected by centrally located escalators and staircases, often in an open core from which they are visible from the surrounding balconies.

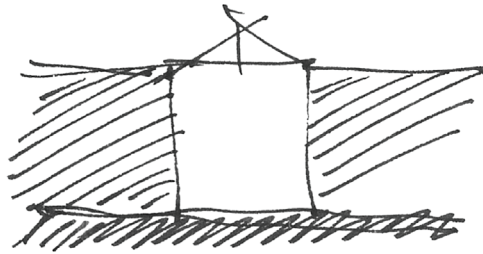

covered passage: typically a roof made out of a transparent material

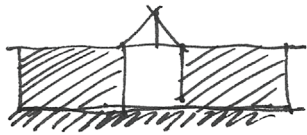

single storey

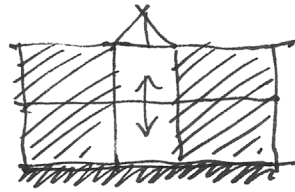

multiple storeys, typically two

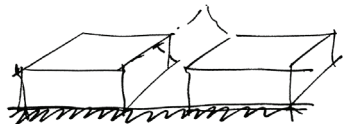

accessible via a same level walkway, only accessible for pedestrians

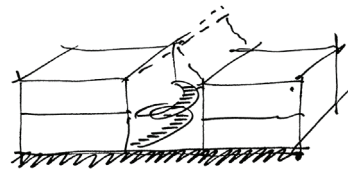

top floors accessible via stairs or escalators in core

The shops are supplied via the pedestrian hallway, or via the backside facing the street. The outer plinth is often blind, without windows. Because all shops are facing inwards (without windows on the outer walls) and the pathways are roofed, there is no direct sunlight in the entire shopping centre.

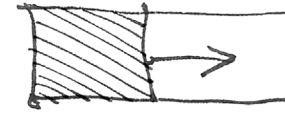

single access: entrance on only one side

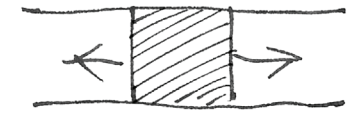

double access: entrances of multiple sides

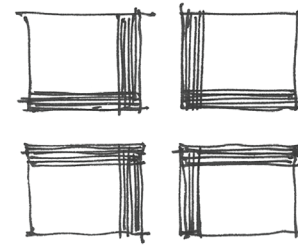

shops facing the interior walkways

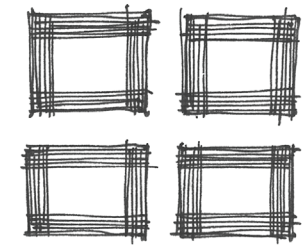

shops on both interior walkways and external plinth

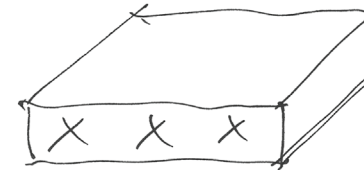

blind plinth: no shops or openings on outer façades, besides the main entrance(s)

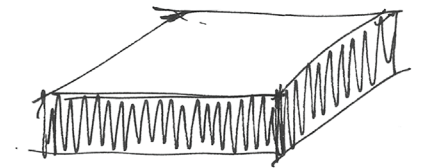

open (shopping) plinth on the outer façades



(a)

location: Winkelcentrum Boven 't Y

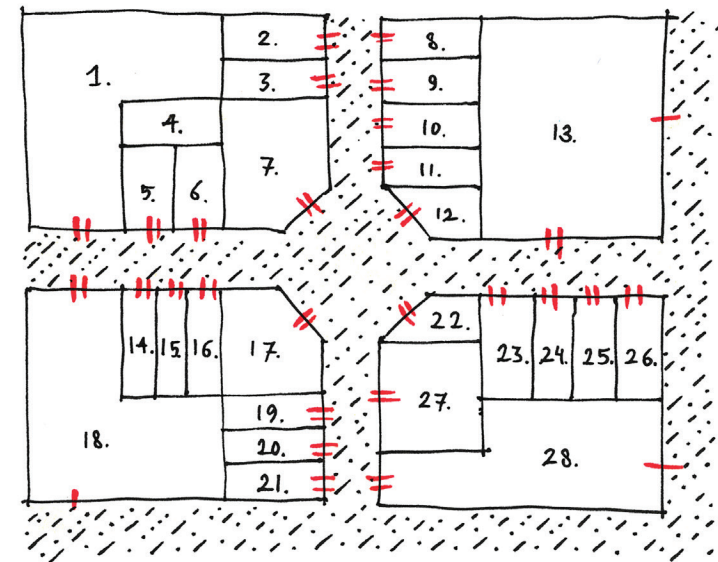
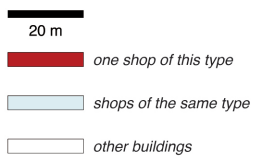

(a)

All shops are accessed from a cross-shaped roofed pathway. A gallery is attached to the facade where shops are accessed from the outside.

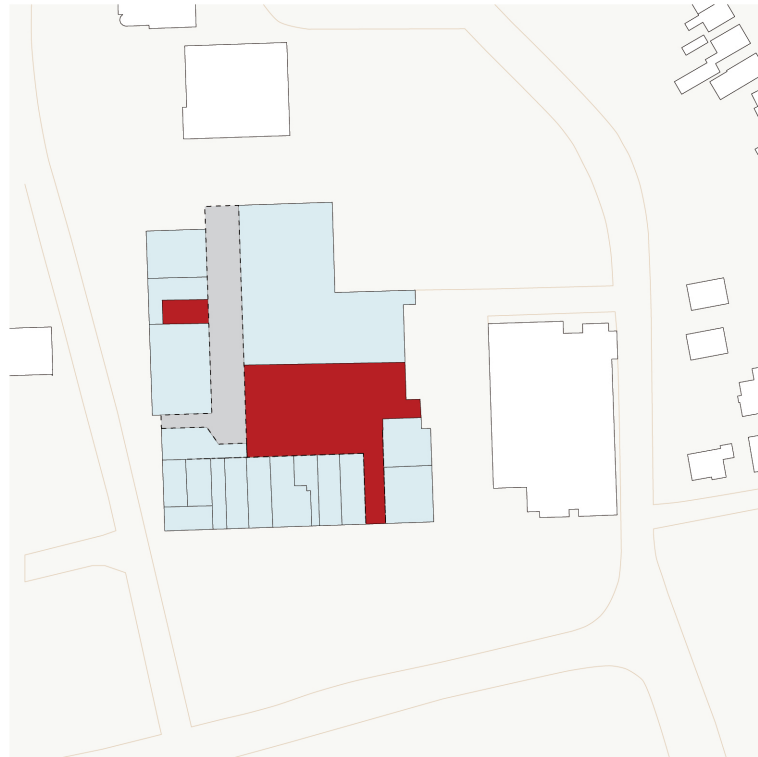

(b)

location: Winkelcentrum Molenwijk

20 m

 one shop of this type

 shops of the same type

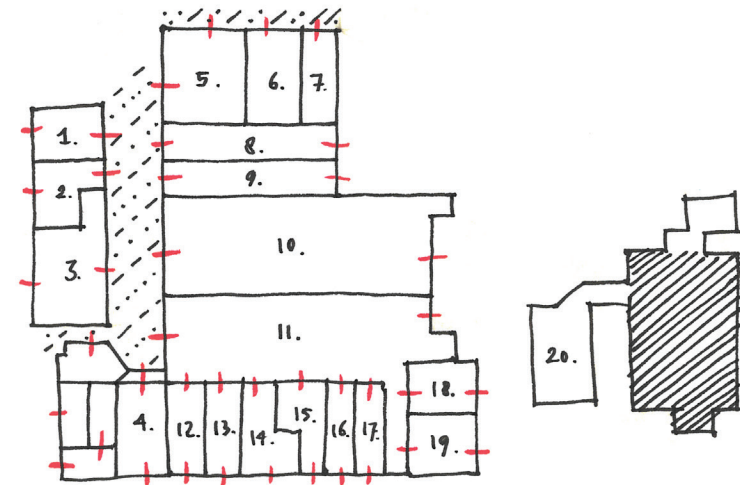
 other buildings

(b)

Through time, new spaces were added to the original structure. All (new) parts are connected with a roof. Shops are accessed by shoppers via the covered pathway, but have doors (without windows) on the back (facing the street) for supply.

TRANSFORMATION POTENTIAL

The building construction is often outdated and in general not suited for housing. Insulation is inadequate, and the mandatory installations (such as sewerage, water- and gas supply) are not present in every shop. The lack of daylight is a problem throughout the building, but this may easily be solved by removing the roofs that cover the hallways between shops. However, this is not always an option. An advantage is that instead of just one shop, the entire structure can be transformed into housing units together. This could press the transformation costs per unit.



Maison de Bonneterie. Rokin, **Amsterdam Centrum** (bron: De Erfgoedstem)



De Bijenkorf. Dam, **Amsterdam Centrum** (bron: Gen25)

DEPARTMENT STORE



A department store (in Dutch: *warenhuis*) is a multi-story shop with a large open plan. There may be sections destined for specific brands, but in terms of structure it should be considered as one very large shop building.

Routing inside of the building is typically organised via staircases and escalators in a large open covered core, with additional circulation cores on the outer corners depending on the size of the building. Direct daylight enters on the side through windows on the outer walls, and from the top via a transparent roof that is often more than 30 metres high. The zones in between may not get natural light. Many of these buildings have monumental value.

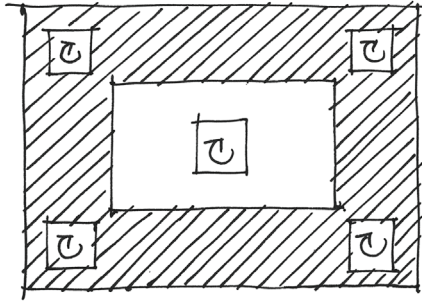

multiple circulation cores

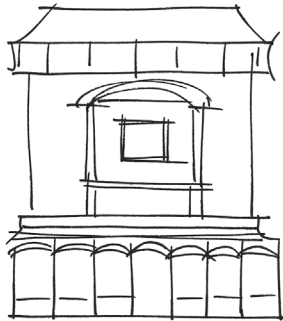

monumental value

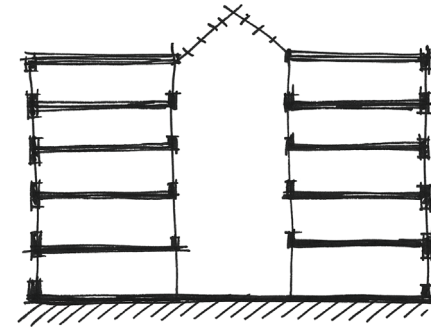

an atrium: an open core with a transparent roof

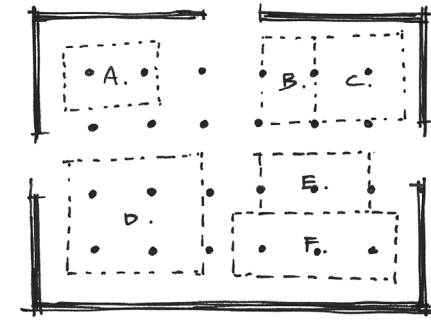

different sections, but only one space / shop



location: Bijenkorf Amsterdam

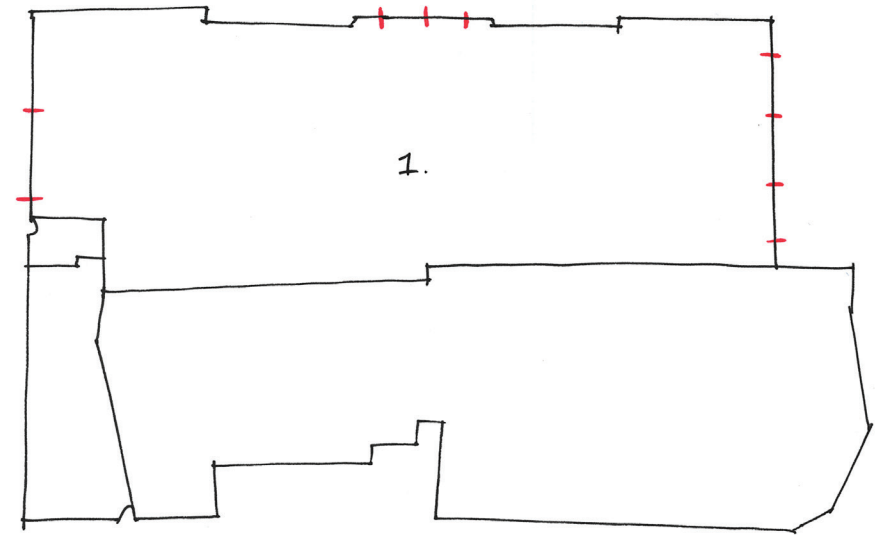
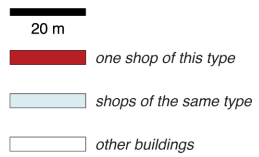

The large building is accessed through one or two entrances on each side of the building.

TRANSFORMATION POTENTIAL

A lack of daylight can be problematic in certain sections of the building, but this may be solved by removing the roof above the core. If the building has monumental value, such changes may however not be allowed. The multiple circulation cores allow access to many sections of the building which could be useful if divided into apartments.

RETAIL ZONE

RETAIL ZONE

Retail Zone are shops in areas on the outskirts of cities. One building means one shop: it does not share with other shops or other functions. Most buildings are unique, but the construction method is similar for all types in this group: often not intended for permanent use, scarcely insulated, with very little natural light. In comparison to the other two groups, shops have relatively large to extremely large surfaces. Generally with one or two stories of which the ceiling height can be several stories high. Buildings are often also showrooms, workshops, storage spaces (of shops) or distribution centres (of off- and online shops). Functions that cause nuisance, such as wood workshops are often found in adjacent buildings.

Since the two types in this group are very similar, characteristics and transformation potential is only mentioned in the first type (small size). These apply for the second type too.

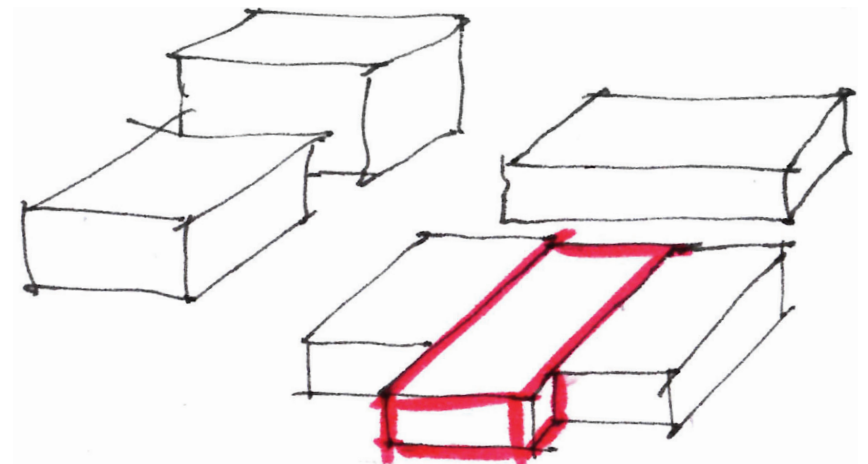



Klaprozenweg, **Amsterdam-Noord** (bron: stadsarchief Amsterdam)



Slijperweg, **Amsterdam-Noord** (bron: google maps)

SMALL SIZE

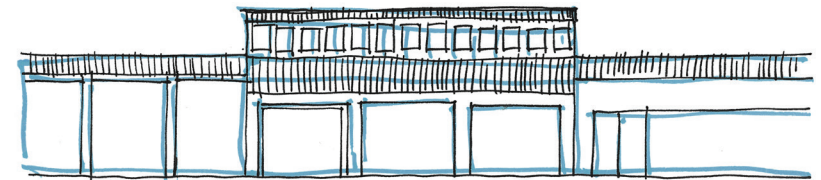

These are buildings in shop areas situated on the edges of towns and cities, or in restricted zones inside of cities. This type is the smallest of its kind, with floor surfaces of several 100m². These shops typically have showrooms or are combined with workshops.

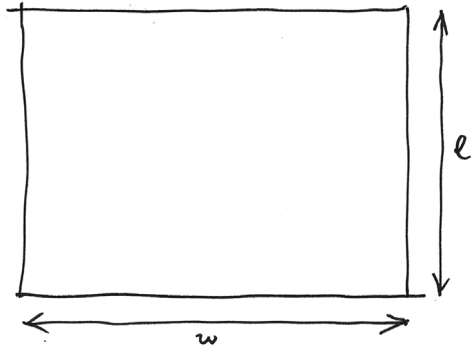
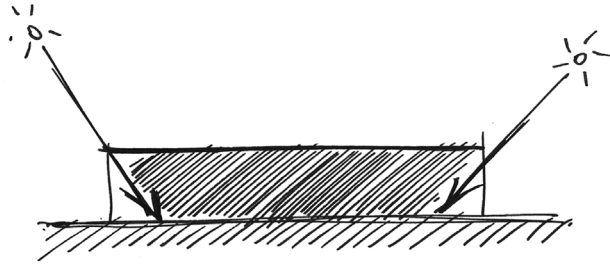

*lack of daylight because of the large floor surface
(and sometimes no windows)*

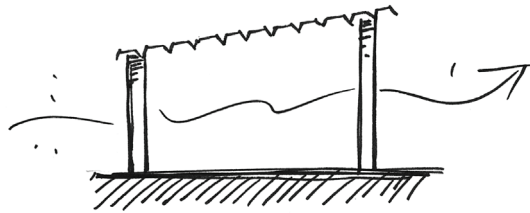

inadequate building construction

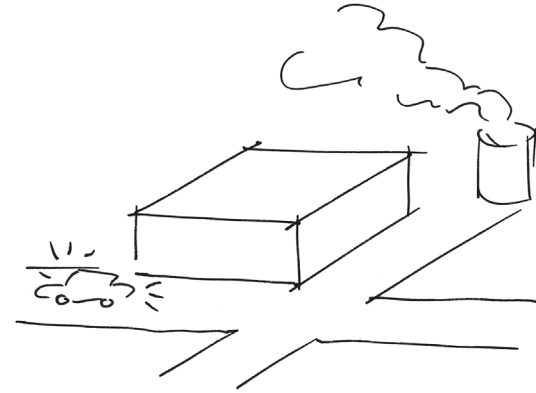



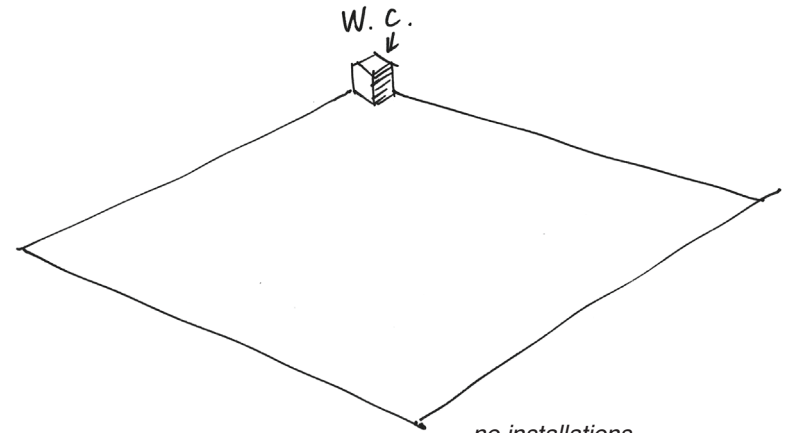

nuisance and unfit public space



no installations



location: Bedrijventerrein Metaalbewerkersweg

-  20 m
-  one shop of this type
-  shops of the same type
-  other buildings

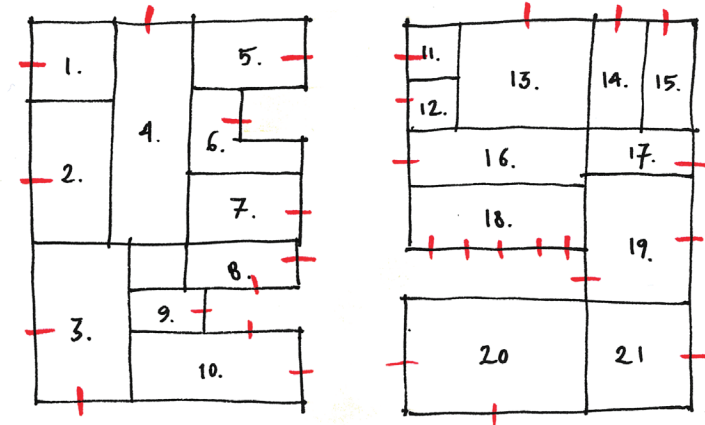

Most buildings can only be accessed from one side because they are attached to other buildings on the other sides. The entrances can be as broad as the entire plinth, and doors can be very large.

TRANSFORMATION POTENTIAL

All shop types in this group have problems with daylight and building construction. The construction, however, is quite flexible and allows for quite drastic interventions such as sawing out a piece of roof to create an atrium, collecting and re-using materials, and creating passages or a gallery with the existing construction. The public space in these areas is not residential and should be transformed too.

Rijnweg, **Delft** (bron: google maps)Euroweg, **Amersfoort** (bron: Holland Luchtfoto)

BIG SIZE

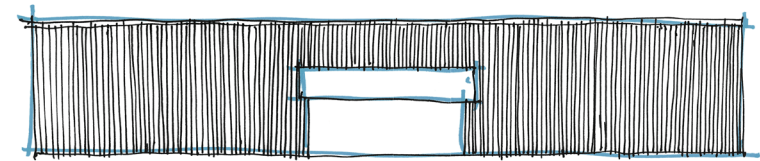

(a / b)

Big size retail zone shops are called PDV's (*perifere detailhandel vestiging*) GDV's (*grootschalige detailhandel vestiging*). These are large scale retail outlets in the periphery of cities. These shops sell products that are too big to fit in typical shops, such as building materials, cars or boats. Floor surface is around 1000m² (PDV) and 1500m² or more (GDV).

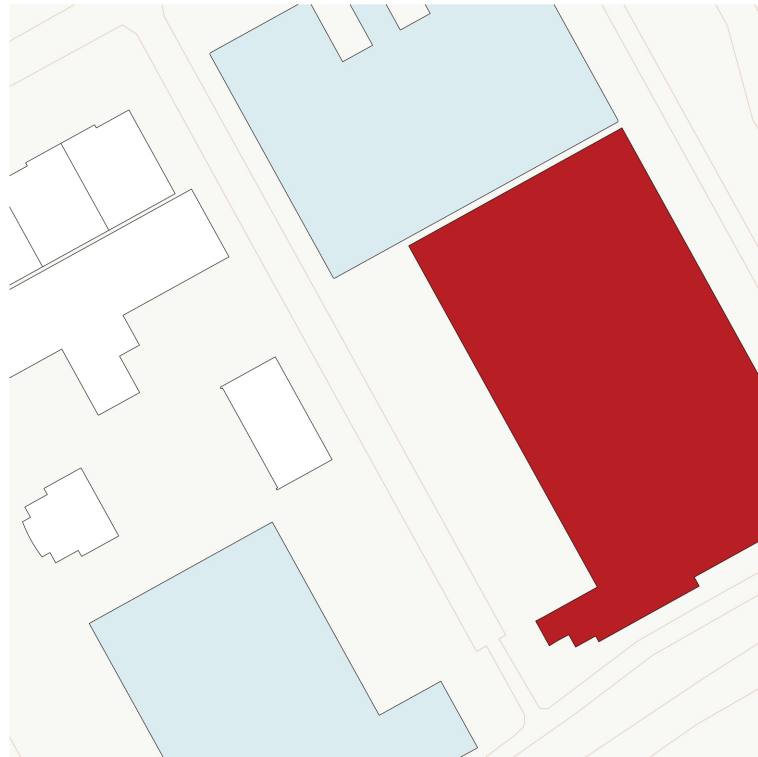

(a: PDV) location: Bedrijventerrein Praxis Zuidoost

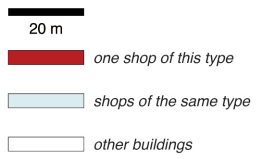

(b: GDV) location: Ikea Amsterdam Zuidoost



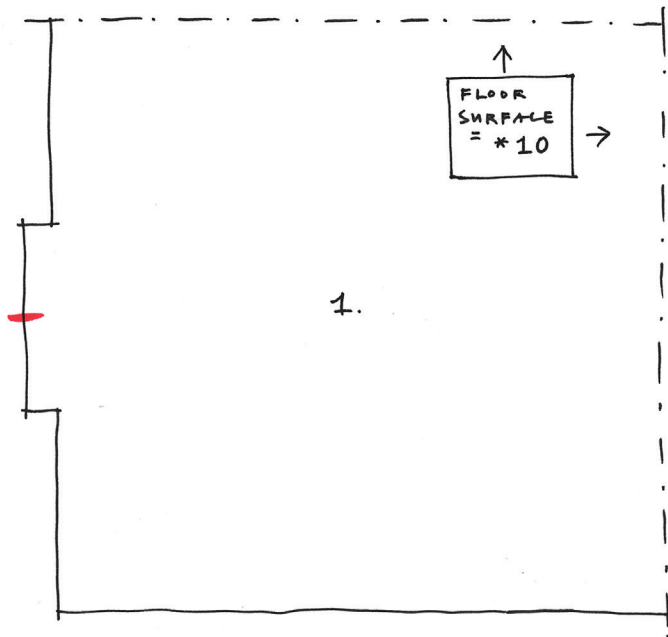

(a / b)

ADD-ONS

There is typically a main entrance for visitors, and other opening on the back for supply. The other walls are 'blind', without any windows.

ADD-ONS

Some qualities or 'add-ons' that determine the transformation potential from shop to housing are independent of type, and can be found among (almost) all types. These are described on the following pages:

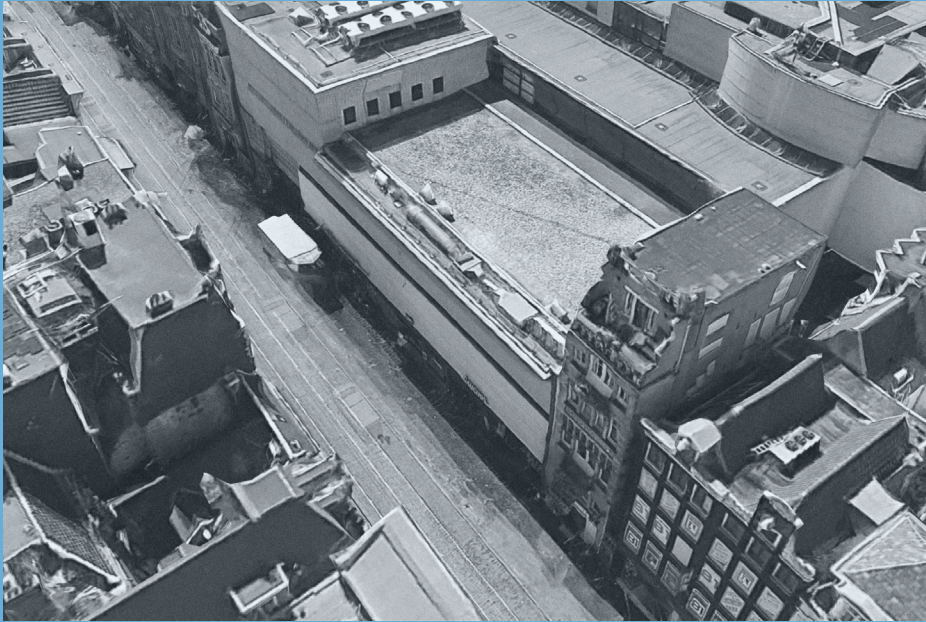
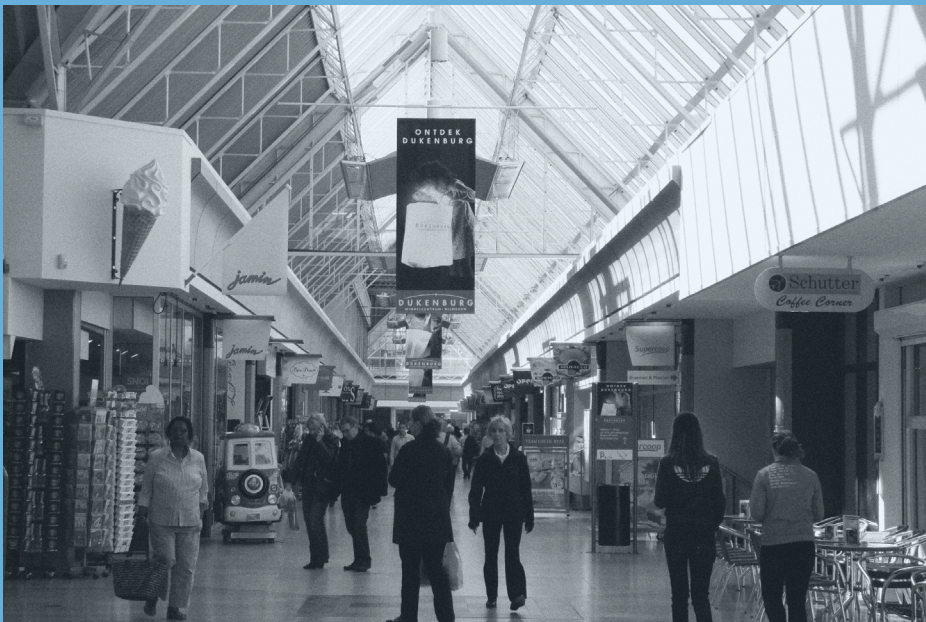
Reguliersbreestraat, **Amsterdam Centrum** (bron: google maps)Winkelcentrum Dukenburg, **Nijmegen** (bron: wikipedia)

LARGE SURFACE

A large surface (top image) is a quality that can be found in densely urbanised areas like city centres, surrounded by other buildings on all sides, except for an opening for the entrance. There can be a long hallway behind the narrow entrance, leading to the shop space itself. Large surfaces are also possible in independent buildings that are not, or only partially attached to neighbouring buildings. The space gets very little to no natural light.

TRANSFORMATION POTENTIAL

Direct daylight must be realised, for example by creating an atrium or removing a part of the building. This is not always possible.

TRANSPARENT ROOF

A roof between rows of shops covering the connecting pedestrian way that lets light through (bottom image). The roof blocks direct sunlight from entering the shop spaces beneath.

TRANSFORMATION POTENTIAL

To make the shop spaces suited for living, the roof may be removed.



Raadhuisstraat, **Amsterdam Centrum** (bron: google maps)

GALLERY

A gallery is a roofed walkway (typically pedestrian-only, but sometimes with a cycling lane) directly connected to the facade of a building, that protects pedestrians against the weather. The roof structure blocks direct access of sunlight on the façade (and in the spaces behind), and the building behind can only be reached by passing it, adding an extra layer of privacy. A gallery can have any shape, size, style or material. It can be part of the original design or added later on.

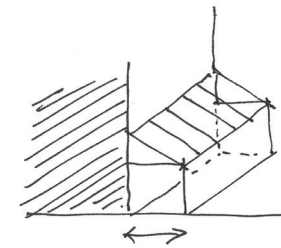

some shop fronts are 'shielded' from the street and traffic with a gallery.

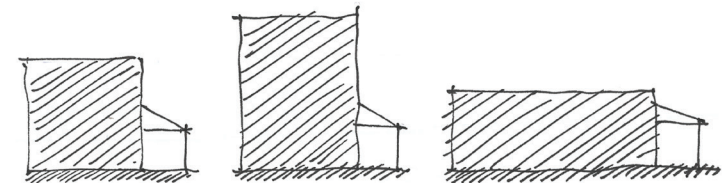

any building can have a gallery attached to it

TRANSFORMATION POTENTIAL

If a gallery blocks sunlight from directly entering the interior spaces of the building, it could be removed. This may be fairly easy to do if it is not part of the original construction of the building. Instead of removing the entire gallery, it may also be possible to only remove parts of the roof to let sunlight through. In this way, the structure can still function as a border between public and private.



Gulden Winckelplantsoen, **Amsterdam West** (bron: google maps)

MIXED-USE

These are shops grouped together with other shops, as part of a large building. The building consists of multiple sections dedicated to a particular function: shops, houses and offices. Shops are clustered under, in the core, on the side, or on the top of the building. These structures often date from the 2000s.

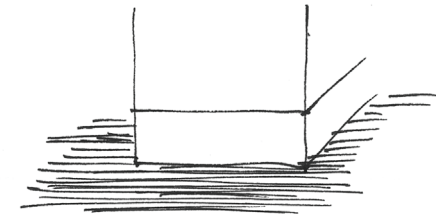

shops on ground level, other functions on the floors above

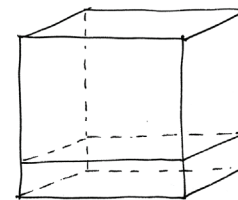

under building: floors above have collective access points

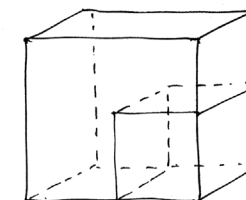

part/corner building

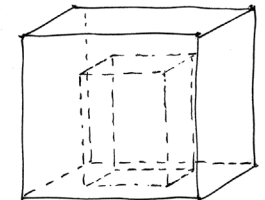

in building(s): no sunlight

TRANSFORMATION POTENTIAL

The transformation potential is very dependent on the specific case. Access ways may not be flexible, making it very hard to transform into housing. It may not be possible to increase sunlight access if an atrium can not be realised (if the top roof of the space does not border open air) and there are not parts of the building that can be removed.



Waterlandplein, Amsterdam-Noord (bron: google maps)

OPEN AIR

Shops in the plinth of separate construction (top and bottom image) facing each other on either side of a pedestrian-only street. The construction could be any shopping complex: a mixed-use building or a shopping centre. A gallery is sometimes added to the plinth, but the space between the shops facing is not roofed.

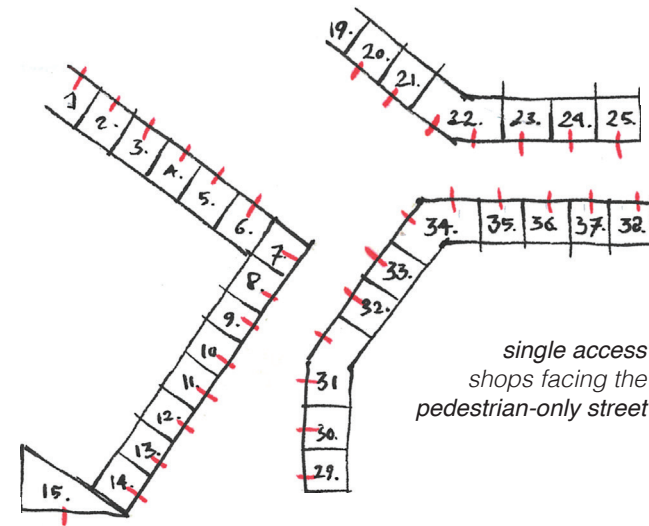

*single access
shops facing the
pedestrian-only street*

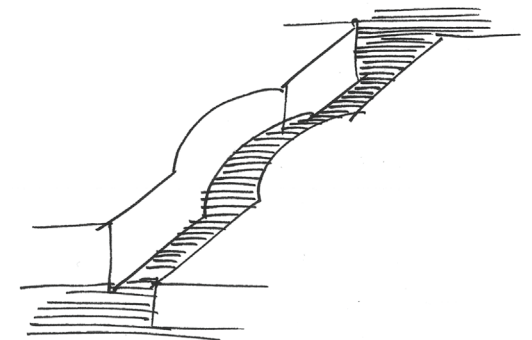

shops in the plinths facing between buildings



Delflandplein, Amsterdam Nieuw-West (bron: google maps)

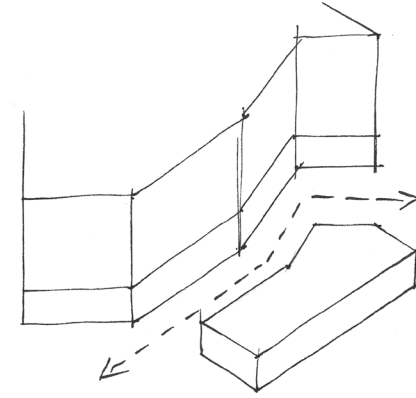

*Access to all shops/spaces in the plinth via a **pedestrian-only street**, other functions are situated on the floors above, and can not be accessed via this street.*

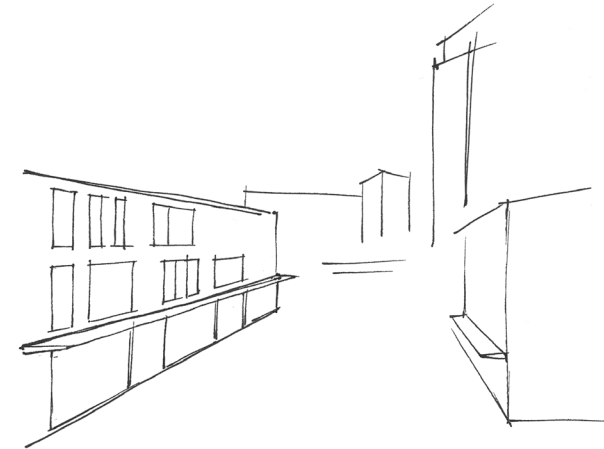

Multiple functions in the area, and different functions on the floor levels above the shops.

TRANSFORMATION POTENTIAL

The street could be redesigned, allowing not only pedestrians to use it.

CONCLUSION

The objective of developing this typology is finding a division between types specifically on the basis of their differences regarding a transformation into housing. However, the problems for all types do evolve around the same topics.

The aspects that determine whether a shop space is unsuited for living are: a lack of daylight access; the absence of minimal technical facilities; inadequate technical qualities (no insulation or ventilation); limited access possibilities; nuisance such as fuss, sound, or as a consequence of specific nearby activities; a lack of privacy or too much direct exposure to the street; the limited suitability for different target groups; or an unpleasant living environment.

The most important problem among all categories is a lack of daylight, mostly because it is often quite difficult or even impossible to solve. Next are access problems and inadequate technical qualities and facilities. Some large surface shop spaces in city centres are impossible to transform into housing because daylight and access can not be realised.

Shop types in pre-war buildings in densely urbanised areas (historic, revolutie-bouw, Amsterdamse school, neighbourhood) are suited for living with relatively small interventions, or none at all. The required adjustments are comparable to a regular renovation, with a focus on making buildings more sustainable or changing the layout. The living environment is suitable for living as it already concerns a residential area. Outliers are shops with an extension and shops at a-locations in the most frequented shopping areas, where access problematic is specific for the particular location (this actually falls outside the scope of this study, because the shop spaces themselves are not empty, but the floors above the shops).

A disadvantage of this category is that if these shops do require dramatic changes to make them livable, it always concerns a tailor-made transformation. This may be more cost- and labour intensive, but also suitable for transformation by private parties.

The redevelopment of an entire group of a block of shops in one transformation can be an advantage because of cost efficiency. This is possible for department stores, and for all post-war shop types (post-war, shopping centre, retail zone small, retail zone big). The later types need this advantage to compensate for all the disadvantages: all the above mentioned problems are present in transformations, and the redevelopment of only the building itself is generally not enough. Public space adjacent to the facade, or in the entire surrounding area needs restructuring.

Retail zone is the group with the most problems along all categories. A transformation involves the entire area and all buildings included. This is not common practice, but apart from challenges it can offer chances in finding creative and innovative design solutions.

OUTLOOK

This research focussed on finding the types and the subdivision between them. If there was more time, the types could have been developed further, specifying chances and challenges, but also some (design) solutions, supplemented with examples of transformation projects from practice. The informed perspective from a real estate, finance or policy angle would make the research more multi-dimensional. Based on the results of the research I have three pieces of advice for policy makers:

1. Focus on relaxing rules for types that are relatively easy to transform, because they require little physical resources and can easily change function again.
2. Make space for large scale redevelopments in sections where this is not yet common practice to allow for innovation.
2. Prohibit the realisation of new built shopping centres altogether. They are not easy to transform and have proven to be neither sustainable nor durable in use. Building them equals building vacancy.

