

# *Design Journal*

Leung Yee Hang | Hembrug Studio

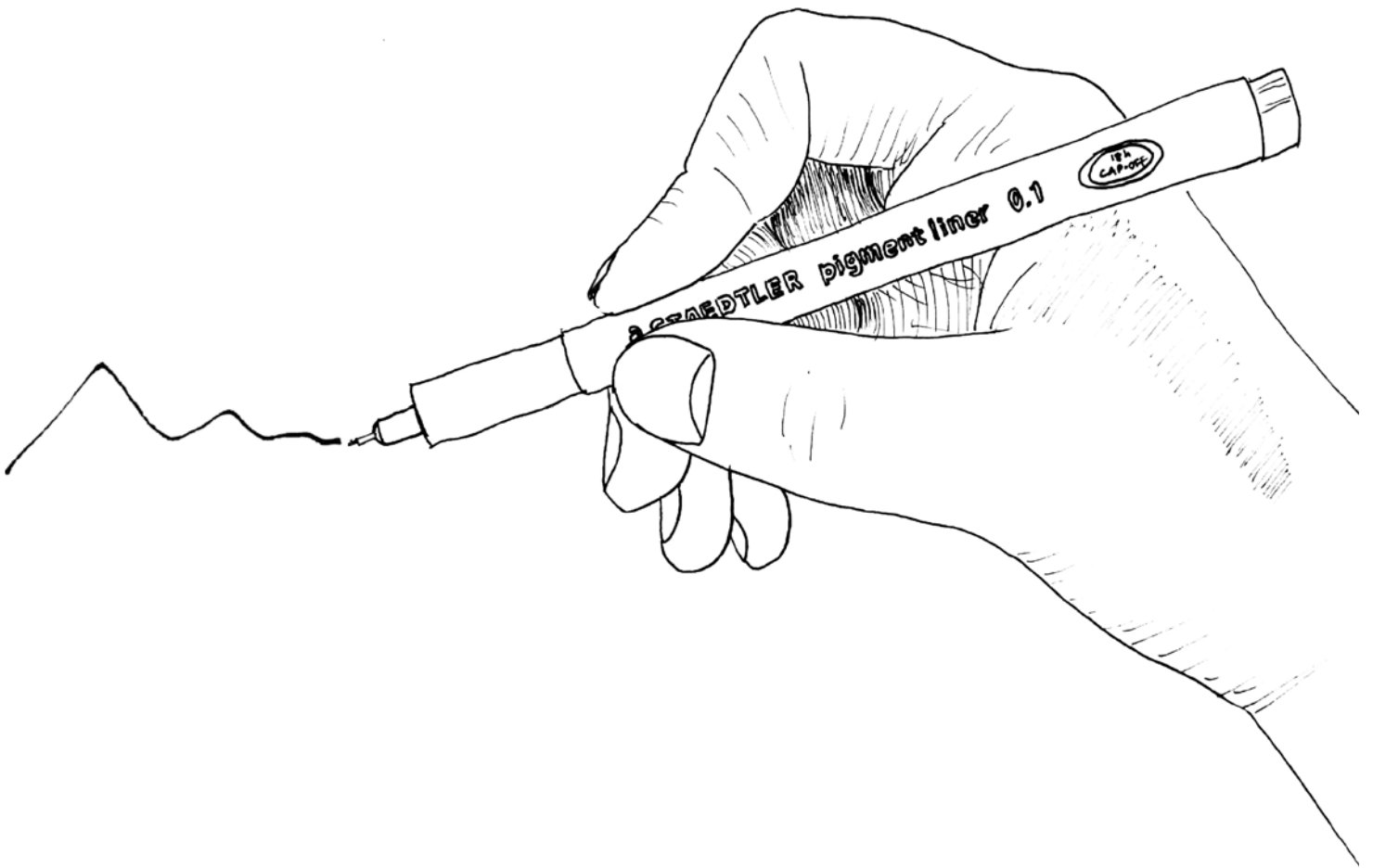





# DESIGN JOURNAL

Leung Yee Hang

Heritage and Architecture Graduation Studio, 2018-19

Revitalizing Heritage

Hembrug Studio

Under the Guidance of  
Prof. Prof. Lidy Meijers,  
Prof. Annette Marx,  
Prof. Frank Koopman &  
Prof. Ivan Nevzgodin

By  
Edith Leung Yee Hang  
Delft, Netherlands  
© 2019  
All rights reserved



# PREFACE

*“Design is thinking made visual.” - Saul Bass*

This design journal aims at recording all the sketches, writings and reflections of every week during the MSc. 3 & 4 design studios. It serves as a manifesto to visualize my thoughts, to express my ideas, to embody my observations and most importantly, to communicate these findings with others. It encompasses loose sketches, short passages and flashes of inspiration. They are presented in an organized manner, so others can derive the line of thoughts and inquiries that led to the final outcome of the design.

Note: Unless otherwise specified, all the photos, illustrations, images and models are author's creation.

# Contents

## P 2

Capturing the past	87
Typological study: The design toolbox	108
Capitalizing the potential	110
A call for cultural landmark	115
Black box theater study	117
Spatial quality of the Cape	118
Learning from Sesc Pompeia	132
Learning from De Luchtsingel	155
Design process	157
The past and the future	161
The paths	169
Current function	171
Future function distribution	172
The path - Past	176
The path - Future	183
Proposed master plan	186
Heritage position	188
Transformation principles	191
Projectile workshop transformation	192
Ammunition factory transformation	212
Commander bunker transformation	234
Cape North transformation	238

## P 1

First Impression	11
Learning from KNSM Island	37
The Head of the Cape	49
Cultural value assessment	50
Building choice	53
Palmbout lecture	57
Role of the Cape	59
Master plan options	61
Minimal changes	63
Add on	65
Reinterpretation	69
Sketched scenarios	71
Model making	76
20x20x20 creation	83

## 00

Preface	5
---------	---

# P3

Learning from LocHal	248
Learning from De Pont	270
Fragment workshop	286
Depth of space	295
Facade study	302
Thoughts about the bunker	305
Landscape design reference	306
Spatial concept	309
Passive design strategy	310
Active design strategy	312
Retractable tube ideas	314
Study models	316
Chances and risks	320
Prosumer culture	323
P3 Presentation	324
Reflection on cultural value	337
Building physics	344

# P4

Site map	352
Target groups	354
Producer, consumer and prosumer distribution	356
Circulation diagrams-visitors	358
Circulation diagrams-artists	360
Circulation diagrams-residents	362
Plans-Innovation Factory	364
Sections-Innovation Factory	368
Elevations-Innovation Factory	372
Plan-Pottery Studio	376
Sections-Pottery Studio	378
Renderings	380
Climatic diagrams	404
Building sequence	414
Details	416

# R

Reflection	441
------------	-----





# P 1

*Every building tells a story,  
if only you know where to look.*



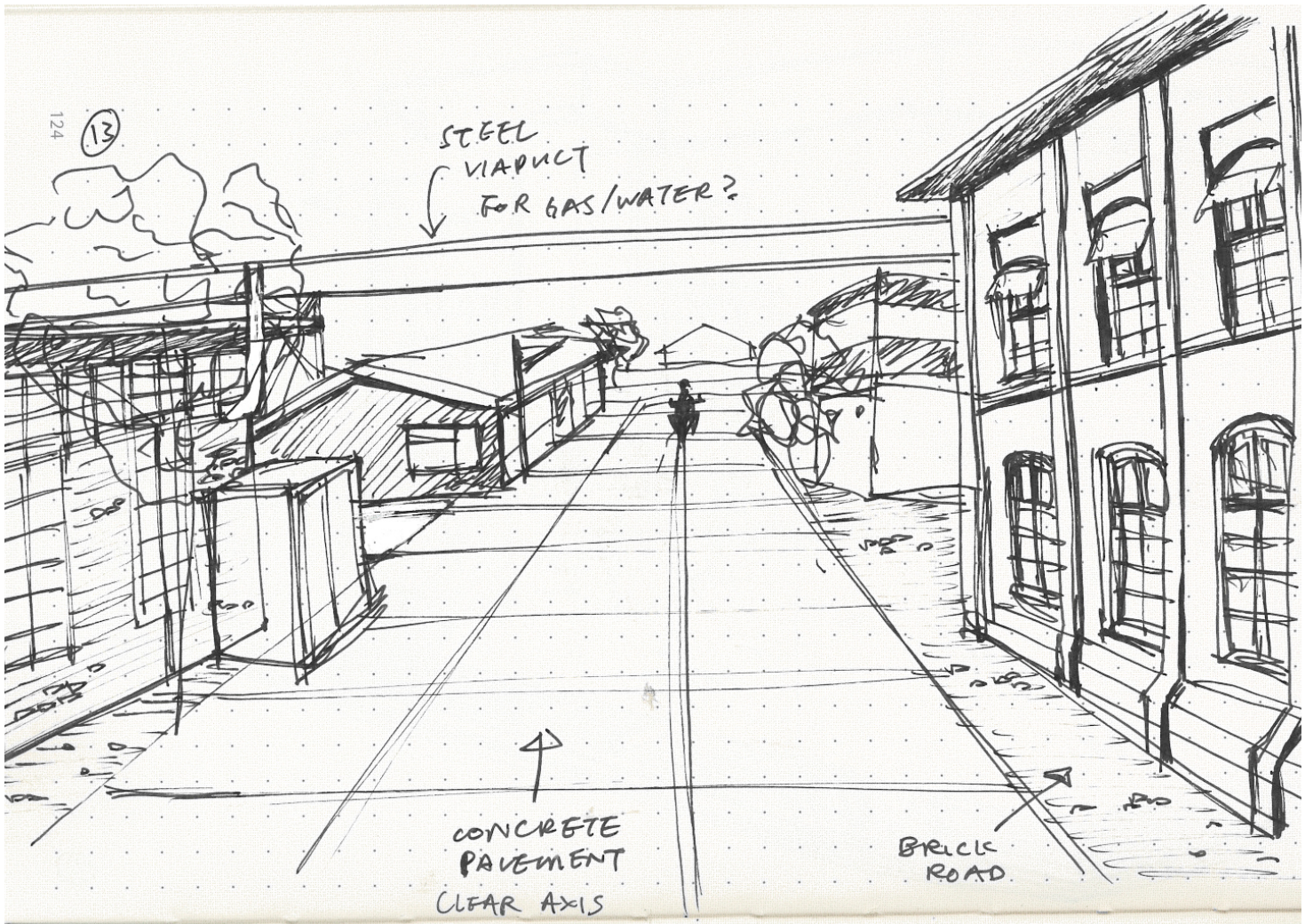



## First Impression

In the first week of studio, all of the students and tutors went to Hembrug for a site visit. Despite the typical gloomy, rainy and windy weather of the Netherlands, we explored the former military ammunition production site with curiosity and an open mindset. We made sketches of buildings, waterfront and open space. We then gathered around and shared our experience. When asked about the first impression of Hembrug, I described the area as “peaceful”. What came to mind as I tracked across the seemingly abandoned streets of Hembrug is that despite the abandoned structures and vacant buildings, there was a hidden quality about the area. The calm water of Noordzeekanaal and the Zijkanaal G, combined with the indisputable presence of the 20th century typologies of the factories, resonated the nostalgic era of industrial activity. At every corner, the spatial qualities of the factories, the precise selection of materials and the untouched, almost wild landscape reflected a lost history that I felt inclined to preserve. With my sketches, I tried to capture the essence of Hembrug’s identity, where I will draw inspiration for my design project.

*Photo:*  
*View from Grote Hulzen road looking towards the Noordzeekanaal*

*Sketch:*  
*Buildings standing at the two sides of the concrete paved Grote Hulzen road*



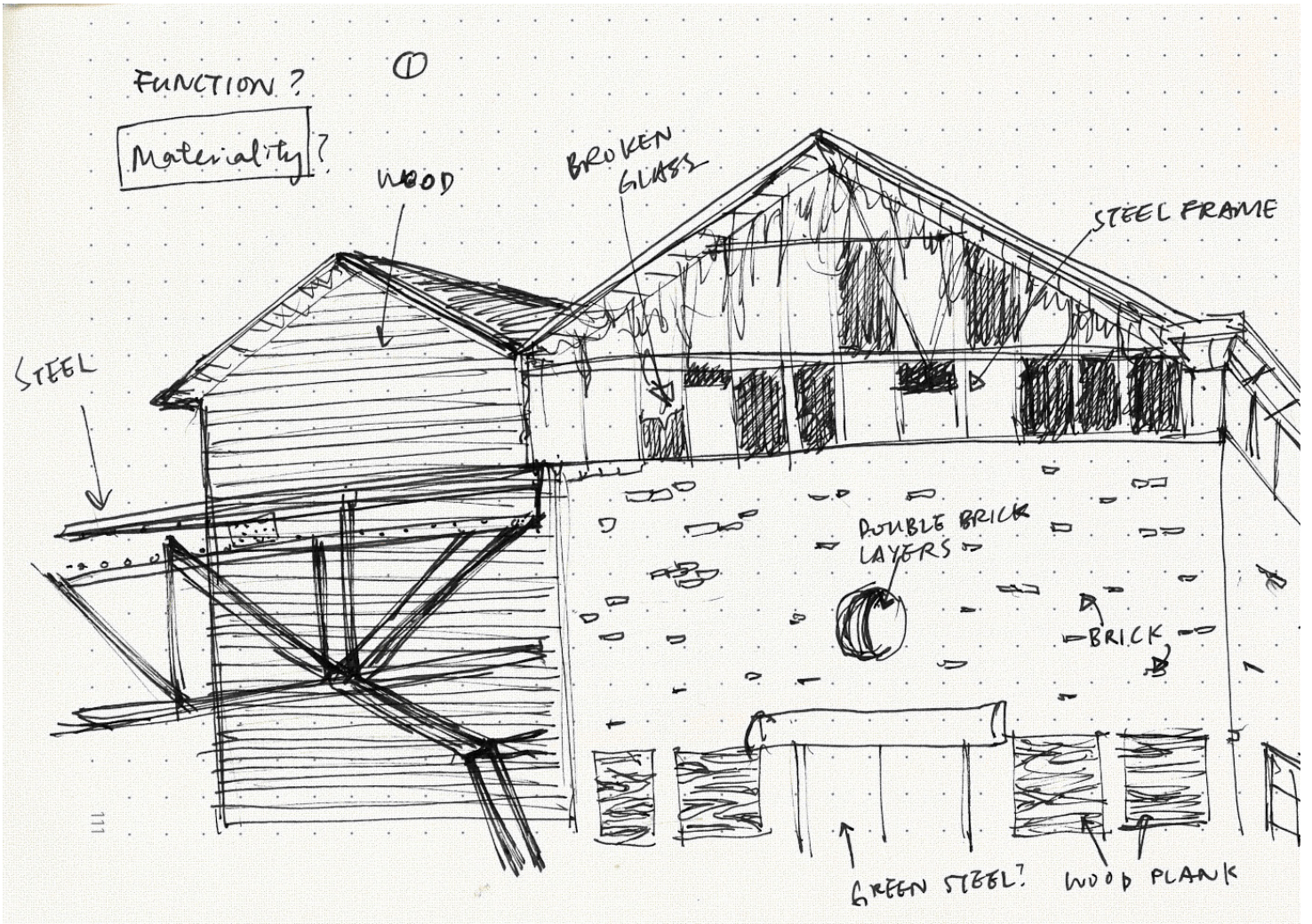



When I first came across this dilapidated, abandoned assembly hall, the rain and fog had just cleared. At the time, there was no one in the vicinity, and as I listened to rustling of the leaves in midst of the overgrown vegetation, I started to look backwards in time to imagine the life that it used to embody. From the cultural historical analysis booklet of Hembrug by Steenhuis Meer, I immediately recognized the distinct typology that reflected the industrial era of Hembrug just before the second world war. The hall could be seen as two interconnected oversized sheds, distinctly characterized with a pitched roof, and the use of wood and bricks; they blended perfectly to create a rather warm tonality. The windows which used to bring daylight into the work area now was broken, with decayed plastic covers hanging in front of the windows, flapping to the wind. The hole in the middle of the facade, which to this day still puzzles me, unveiled the typical construction of the period, two layerings of bricks with a cavity wall. There are traces of steel that was used to construct the sliding door, with four concealed windows, two on each side – they made up the entrance hall of the former assembly hall. I imagined workers, some of my age and even younger, bustling in and out of the hall, assembling the munition to prepare for the dreaded upcoming war. A rusted steel truss collided with the wooden shed on the left, a former crane used to load raw materials. Together, all the elements whispered a story of Hembrug, a story that can be only heard if you knew where to look.

*Photo:*  
*The former assembly hall*

*Sketch:*  
*The different materiality on the facade of the assembly hall*



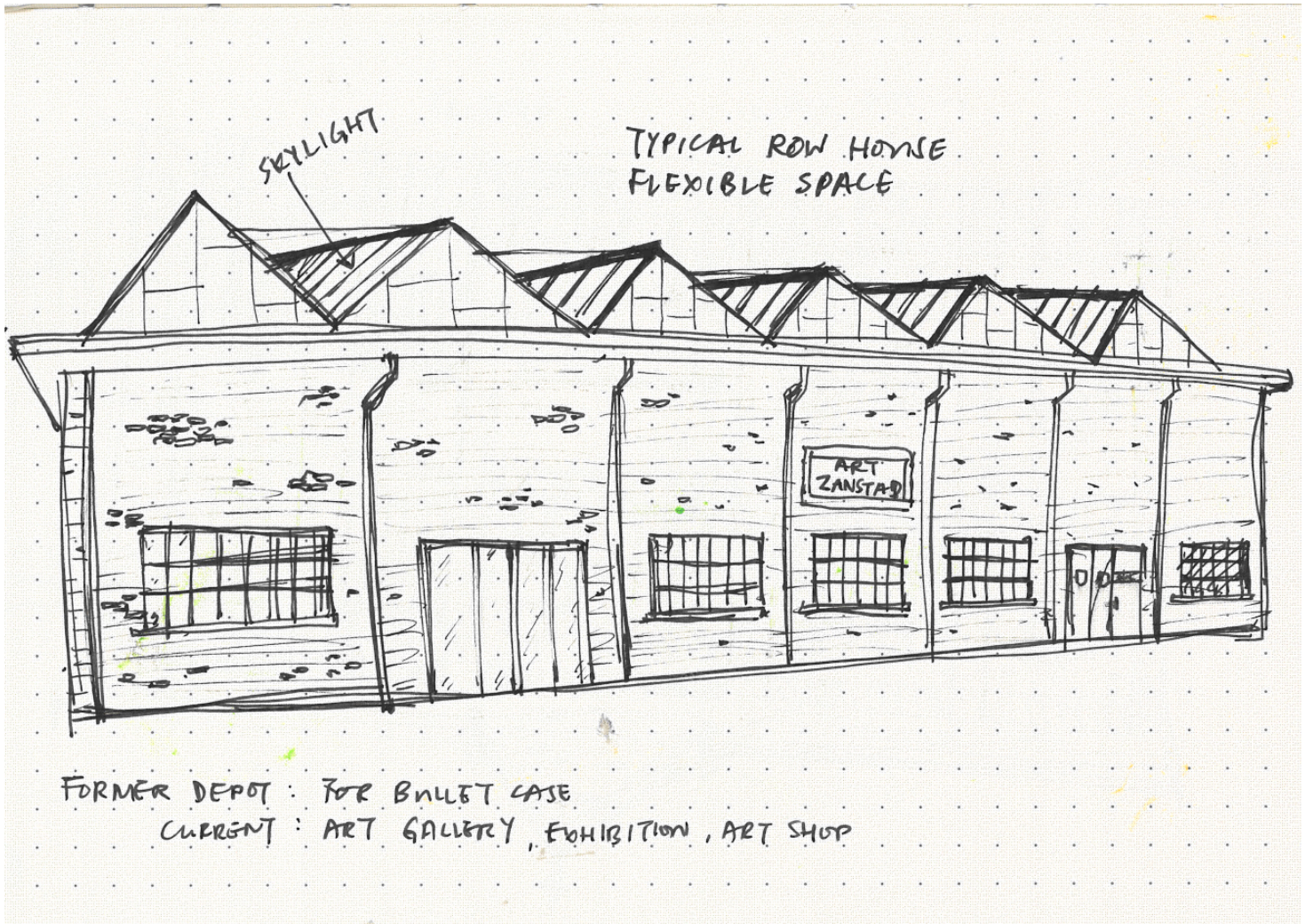



As I dashed into the building to take shelter from the sudden rain, I found myself in an expansive elongated hall, completed with floor heating system and a refurnished interior. As I warmed myself near the entrance, a charming lady – the cashier of the art gallery approached me and we had a very pleasant conversation of the place and what it used to be, a former cartridge factory. As I walked solitary down the hall, examining the handicraft and paintings, my mind wandered elsewhere. I looked into the distance, and saw a worker carrying boxes of cartridge, a colleague of his was loading gunpowder into the shells, while chatting to his partner about his plans for his family and future. Across the end of the hallway, I can almost hear the commander yelling at them to keep working, his voice echoing across the expansive room. This almost surreal flashback was rudely interrupted as I mindlessly hit a steel column.

*Photo:*  
*The former cartridge factory*

*Sketch:*  
*The roof skylights are visible from afar*



3



As I exited from the art gallery, I came across this grandeur building, a monumental construction of the head office of military production. The exterior reflected the superiority of the resident, with the intricate facade design, the elevated entrance, and the emphasis on verticality. As I walked into the building, a visitor brushed past me, and for a second, I could almost swear it was the military commander in his smart attire, with his wife in his arms wearing an elegant dress as they descended to go to a dinner event.

*Photo:*  
*The former head office of the military production*

*Sketch:*  
*The north facade of the building*



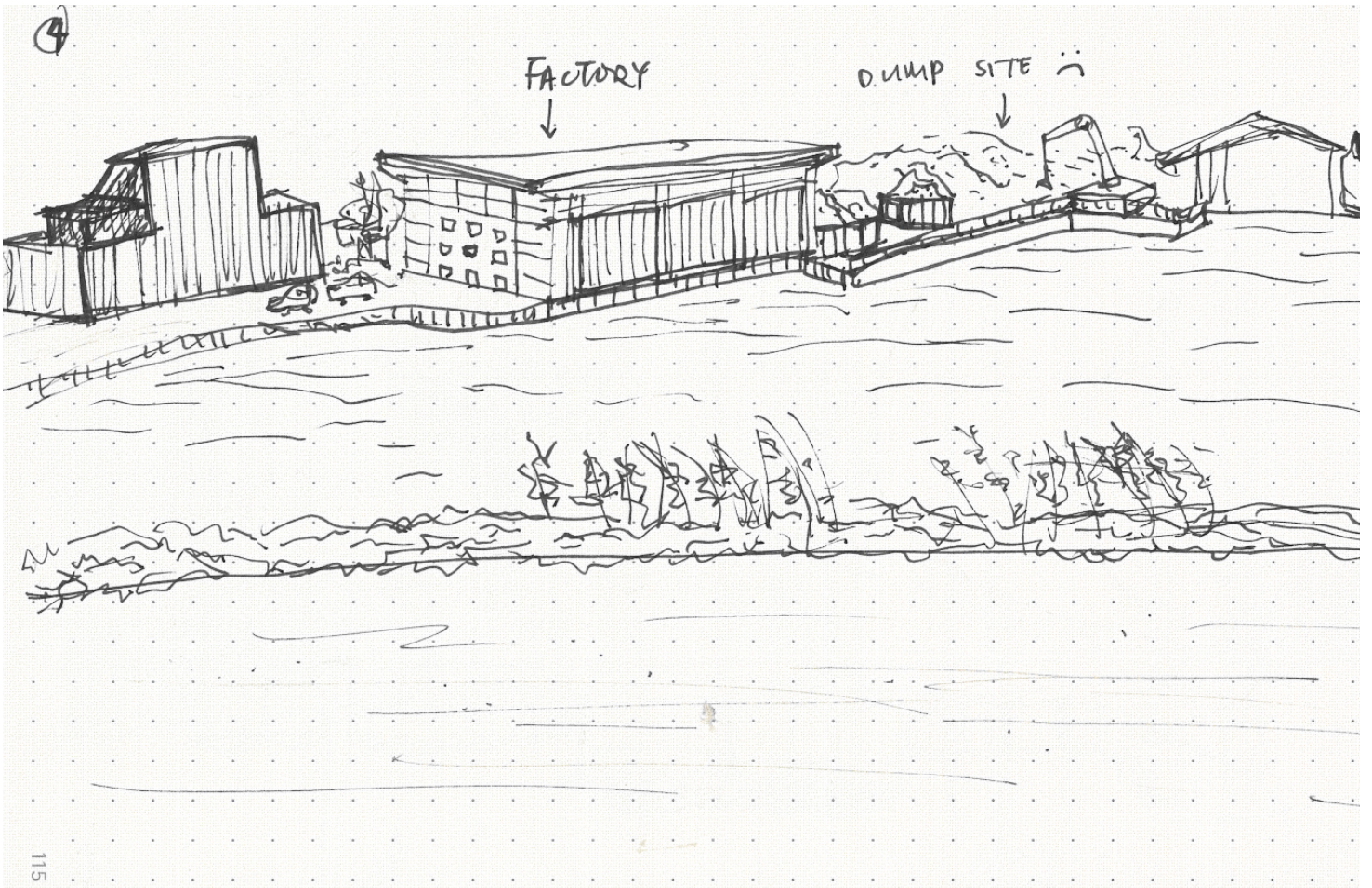



When I was walking down the waterfront, my peaceful stroll was disturbed by the noise from the opposite bank of the Noordzeekanaal; it came from the eyesore over the canal, a dumping site with working factories and warehouses. I pondered whether in the past it was just as loud and noisy – but surely it had to be, with warships that occasionally passes by, with workers in old uniforms and caps singing merrily, or drunken ones at night wandering down the path supported by their comrades in arms.

*Photo:*

*The pier at Havenstraat; the background shows the dumping site across the Noordzeekanaal*

*Sketch:*

*The dumping site across the canal*



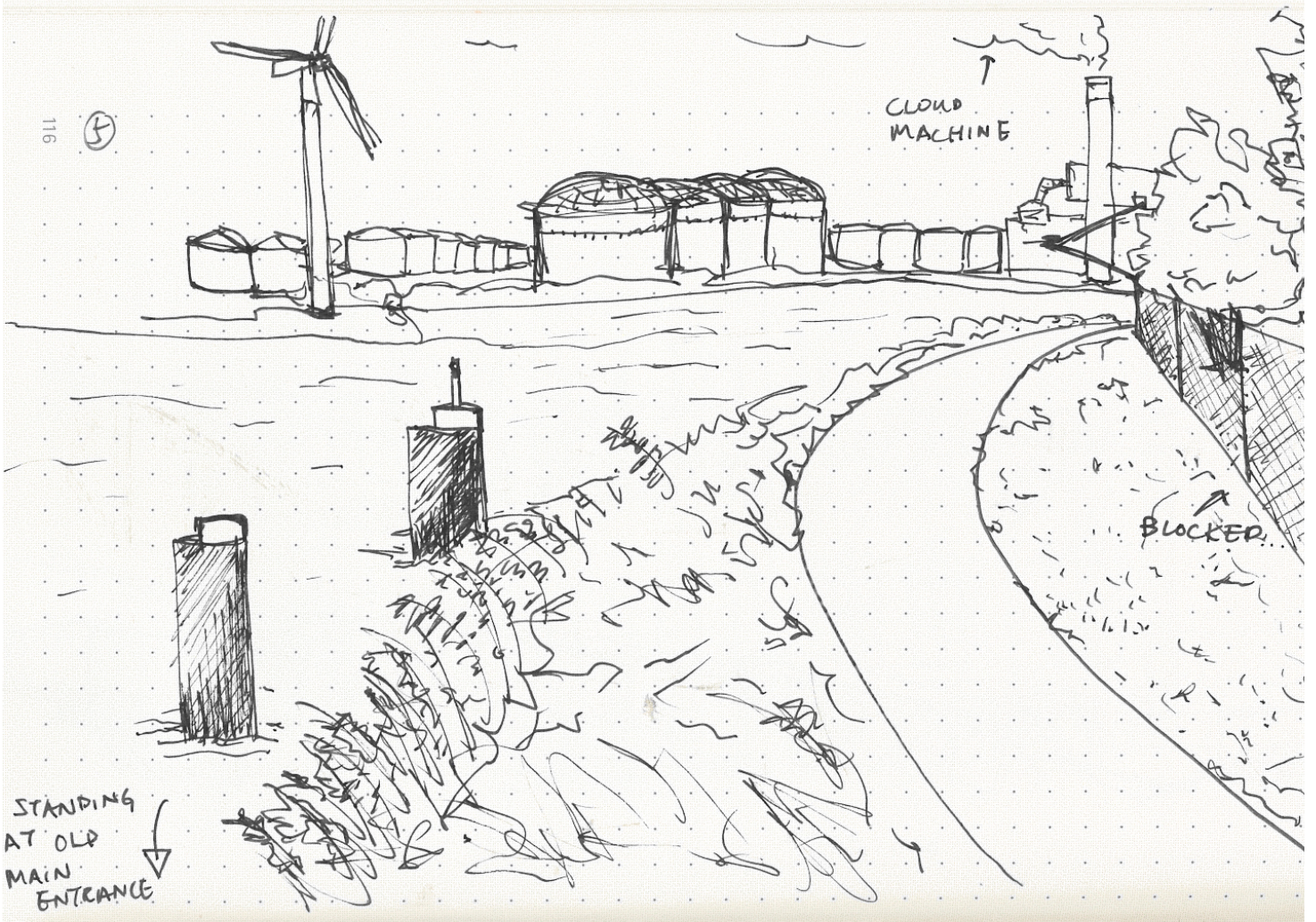



As I meandered down the path, I came across an area where the waterfront was completely fenced off which left an overwhelming hostile atmosphere. At the distance I could see a “cloud machine”, and it occurred me that maybe in the past, there were more of these “cloud machines”. I had an epiphany on how much the world has progressed. Right next to the factory, there was a windmill, and despite the nostalgia of the pass, I was grateful that the future was more optimistic.

*Photo:*

*The waterfront Havenstraat which is completely fenced off*

*Sketch:*

*The smoke from the chimney blends with the sky as if it is a “cloud machine”*





⑥

MONOTONIC  
INDUSTRIALISED  
LOOKING PROFILE

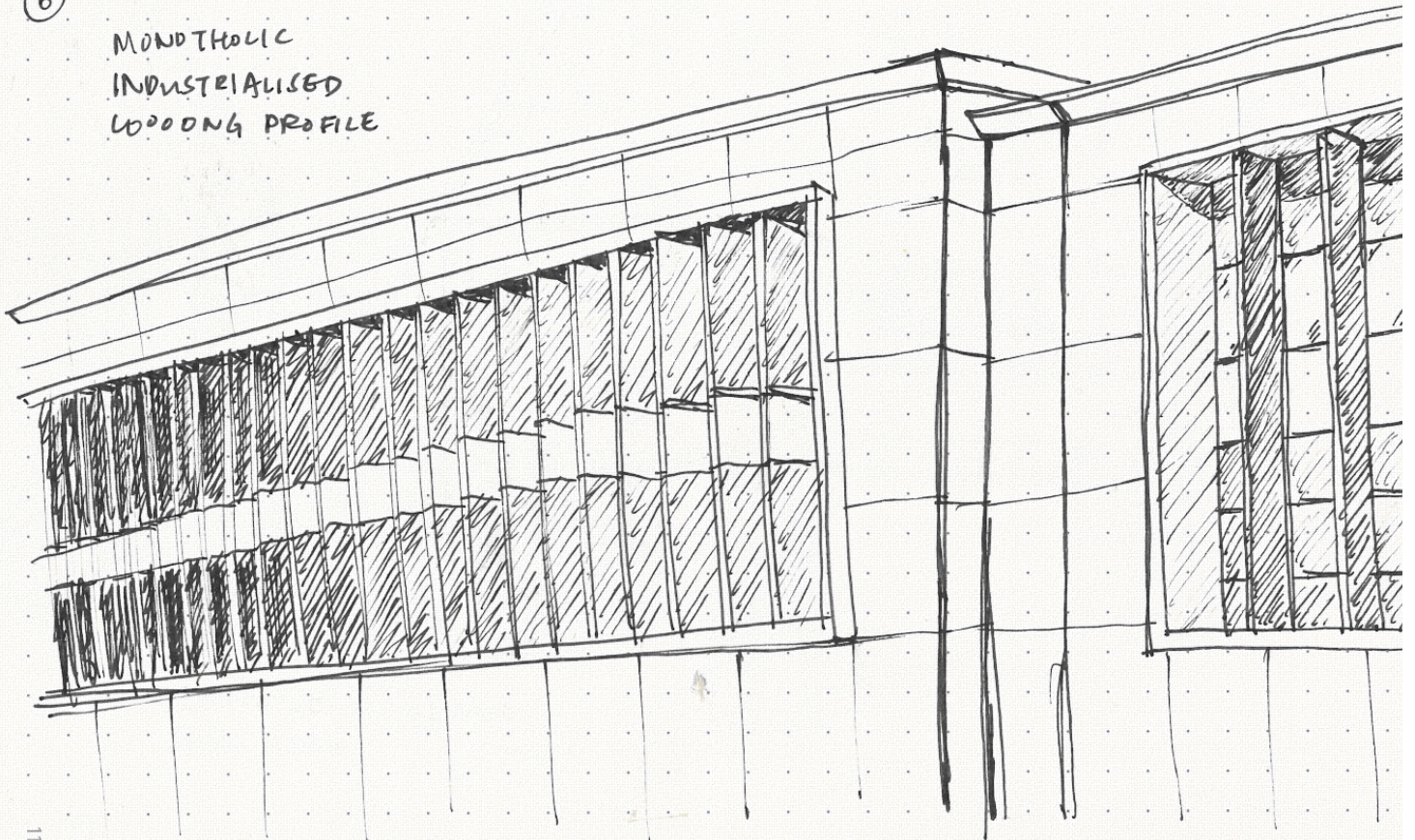



Along the Havenstraat, there was a massive factory behind the fence. I recently came to know that OMA was going to transform the building into an art exhibition center with hotels and restaurants, with a large long flat box hovering above the existing factory. As I imagined this light box above the factory, I could almost see the superimposition of past and future in the present. In my mind there were two parallels of activity, one from the past, one from the future happening at the same time - the factory workers carrying boxes of crates and loading them into ships, meanwhile tourists were sitting in the new structure overlooking the canal as they had their dinner and pleasant talks in the restaurant.

*Photo:*

*The ammunition factory along the Havenstraat*

*Sketch:*

*The repetitive brise-soleil on the southwest facade of the factory*







When I walked into the terrain, tired, cold and in desperate need of coffee, I was eternally grateful to be welcomed by a café that was transformed from a former station for mechanical vaults. The warmth and hospitality of the café created an almost poetic juxtaposition with the abandoned and expired infrastructure, and at least for me, this contrast created an extraordinary intangible beauty.

*Photo:*  
*Interior of the Cafe transformed from a former mechanical station*

*Sketch:*  
*The cafe is situated along the road where the expired steam pipe runs through it*



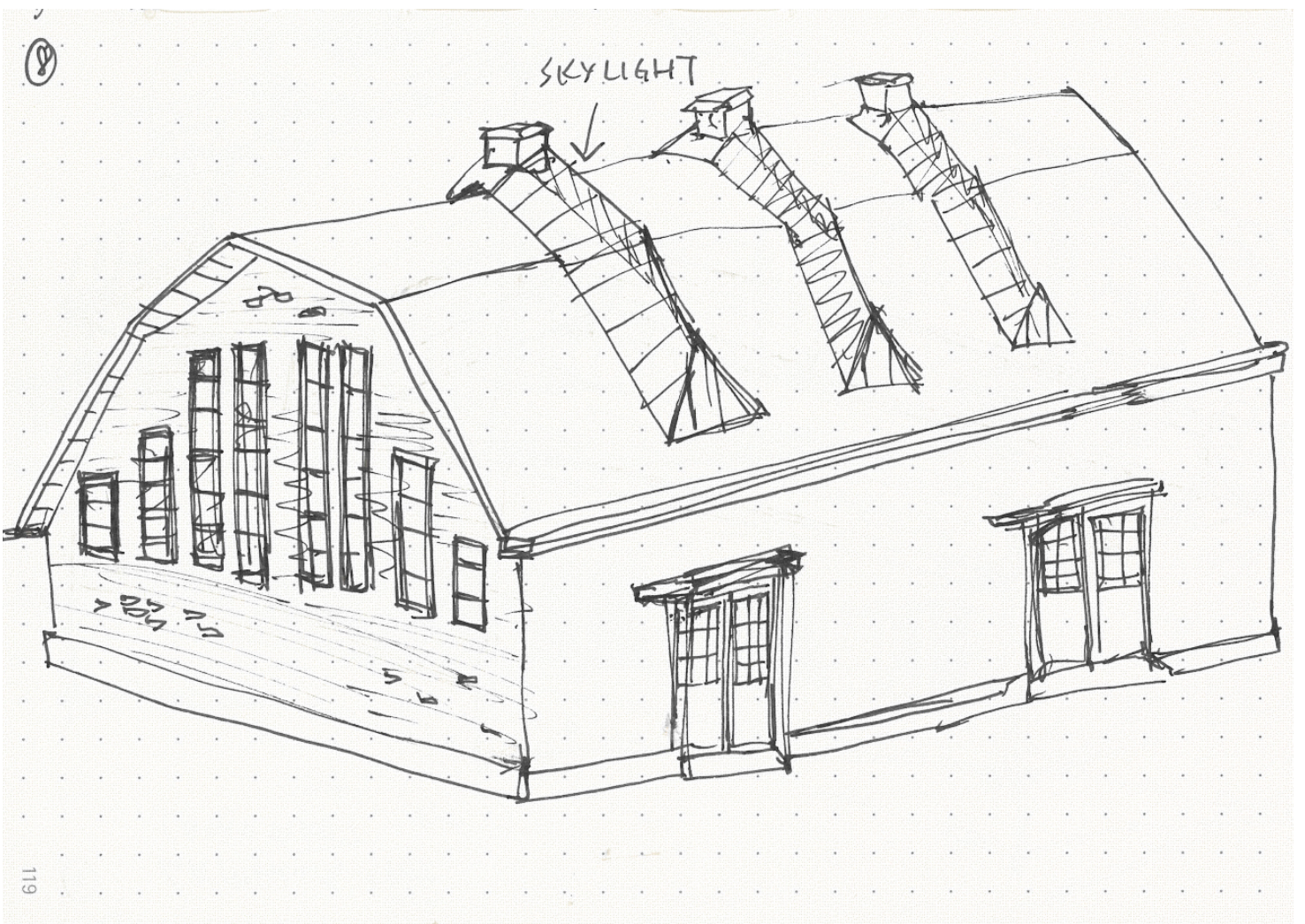



Having thoroughly enjoyed my cup of coffee, I decided to explore a bit more and came across a former changing room with a gambrel roof. As I sneakily peaked into the protruded entrance, I noticed that the interior was lit up beautifully with the skylights from above, and it occurred to me how it must have been such a great place for changing clothes.

*Photo:*

*Peeking into the former changing room*

*Sketch:*

*The skylights from above which lit up the interior adequately*





⑨ GATHERING SPOT  
CAMP FIRE?

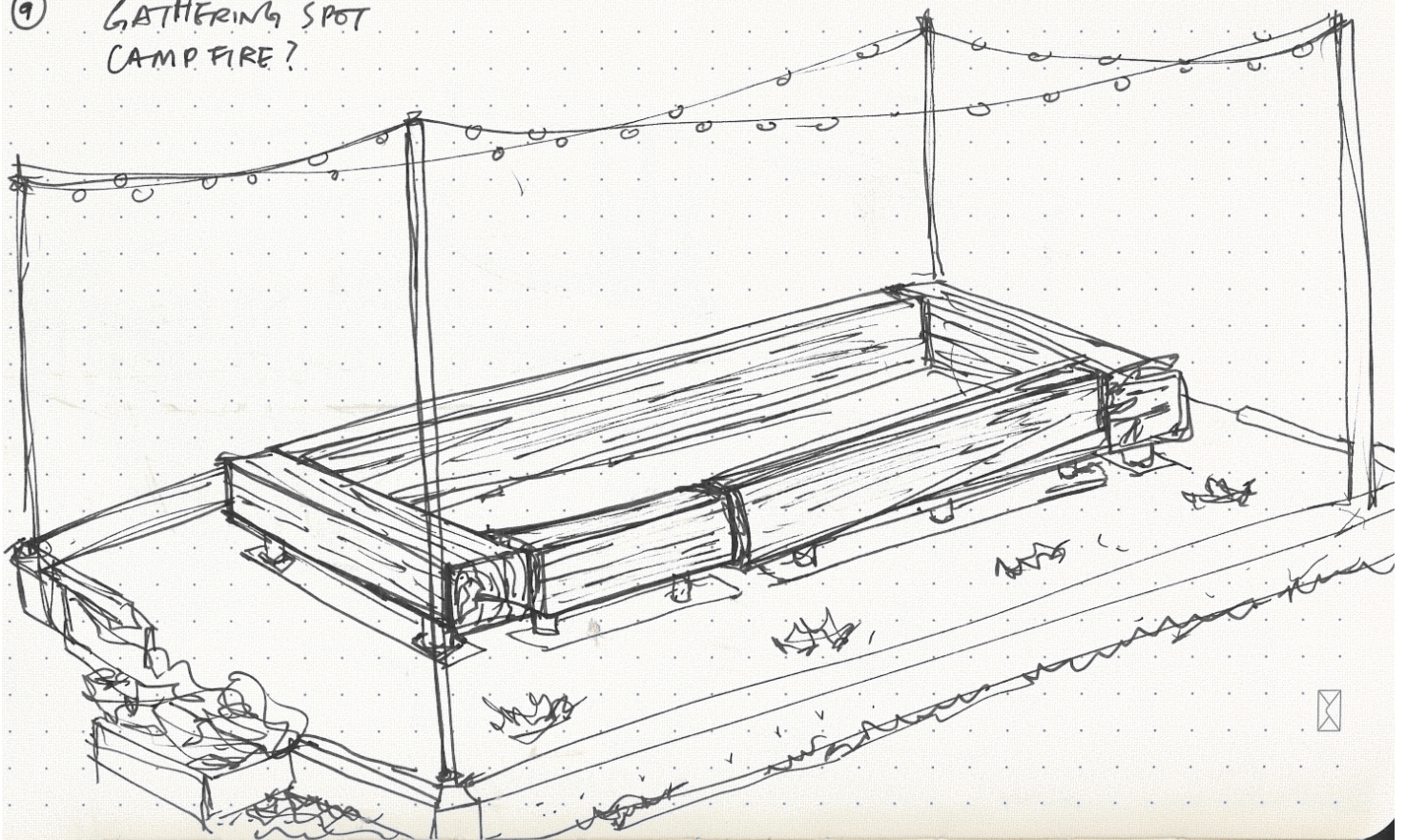



As I stepped out of the glorified changing room, I realized that there was an elevated platform. There were traces of partition walls and pits which implied that it housed some sort of function. Although it indicated a toilet, I was more intrigued by how the layout of the wooden benches were arranged to suggest some sort of gathering place. Perhaps there was the cold, the wind or both, but I could totally imagine it to house a cozy fire, as people gathered around merrily with beers in hand enjoying the warmth in the dead of night.

*Photo:*

*The elevated platform left from a former toilet*

*Sketch:*

*The arrangement of wooden benches suggests gathering events*



10

BERLIN BANKHAUS MUSEUM. HAKA X

DDD

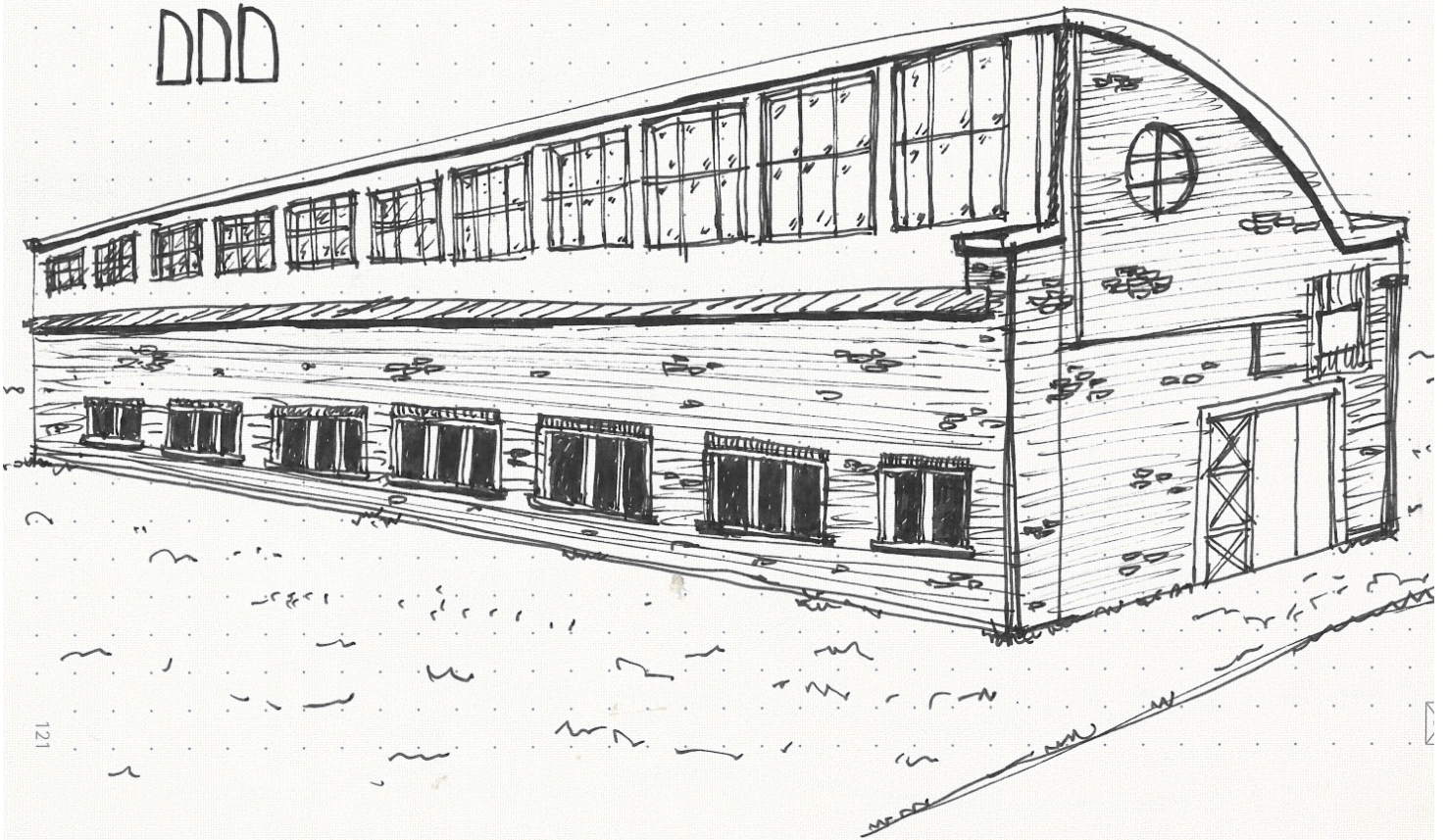



I was perplexed when I first saw this building in the midst of the woods. It was in a rather intriguing shape, with a curved shell roof. When I peeked inside, I realized how it created perfect lighting conditions to hold an event or exhibition, and was surprised that it was initially designed to direct smoke towards the forest in case of an explosion. It occurred to me, how a building such as this, can capture the past, yet at the same time be used to accommodate for some future activity that is more relevant for today's society.

*Photo:*

*The windows from above create perfect lighting condition for exhibition*

*Sketch:*

*The curved roof profile of the building reminds me of the Bauhaus Museum in Berlin*





122

①

CAMP SITE?  
OPEN AREA  
FOR PUBLIC





As I finally found my way out of the dense derelict woods, a vast green lawn with a few camping cars welcomed me back to civilized society. It reminded me that there were not only buildings in Hembrug but also outdoor spaces which awaited to be discovered , transformed and revitalized.

*Photo:*

*There were some camping cars on a piece of lawn. People were chatting underneath the tent which was extended from the camping car*

*Sketch:*

*The camping car and the tent*



(12)

FORMER: GUN  
POWDER  
CURRENT: WORKSHOP  
CAFE

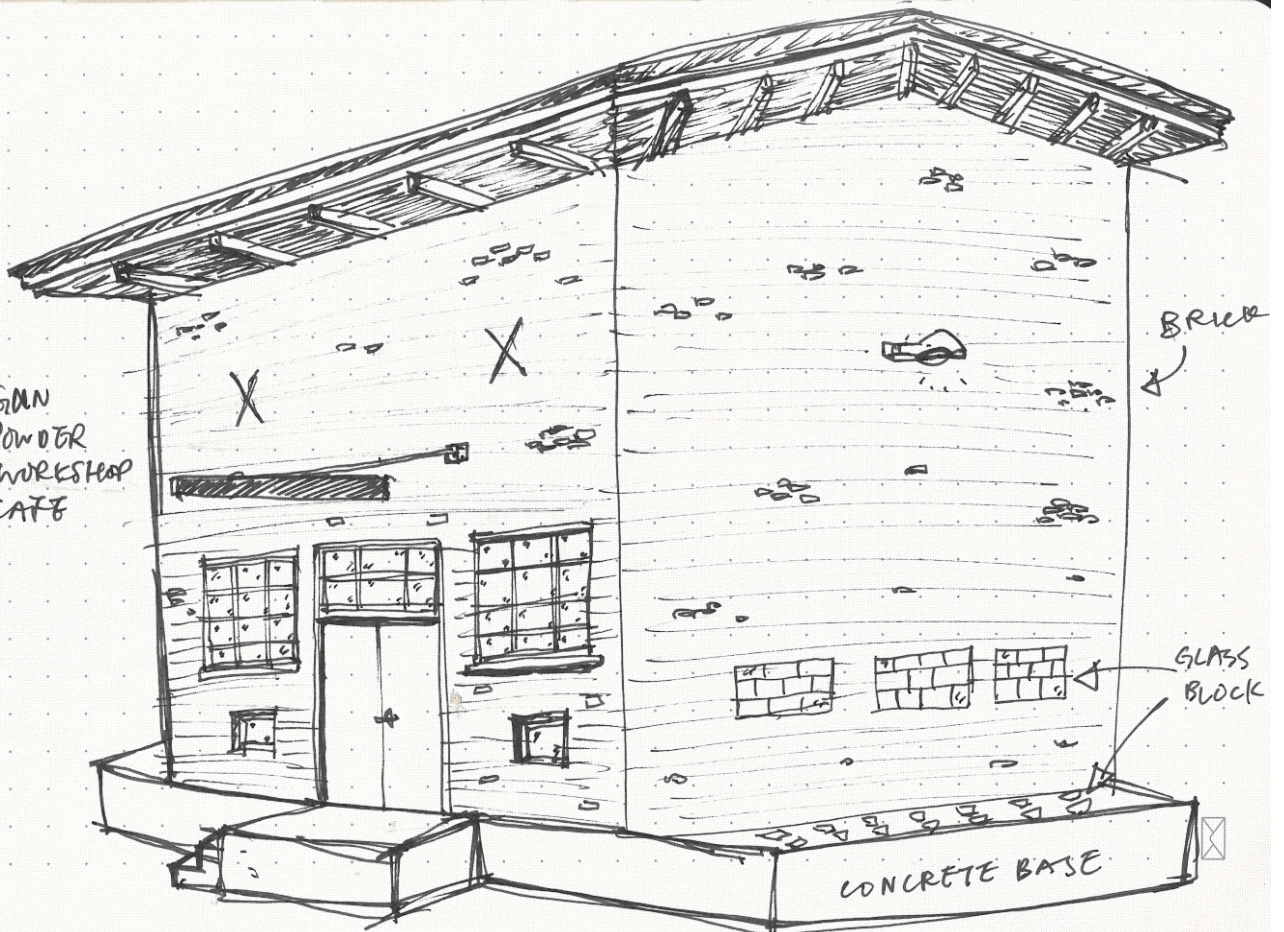



When I was about to leave the Hembrug terrain and to call it a day, a human-face like building lured me back into exploration. A friendly lady invited me to go inside the building and proudly presented me her own photography studio transformed from a former gun powder storage. She turned half of the basement into a shooting studio with a darkroom for developing photos and the other half as her own private lounge. Slickly planned, the glass blocks embedded in the concrete base on the ground served as a light well for the basement.

*Photo:*

*Light penetrated through the glass blocks to the basement*

*Sketch:*

*The human-face like photography studio*





# LEARNING FROM KNSM ISLAND

## **Introduction**

This week we have looked into a case study - the KNSM Island to examine the transformation of an abandoned shipping dock to a residential area (please refer to the KNSM Island booklet for detailed analysis). This example provides an insight into the design of the Hembrug terrain. The following summary extracts some lessons that I have learned from this precedent study.

*Photo:*

*Aerial photo of KNSM Island*

*Source:*

*[https://siebeswart.photoshelter.com/  
image/I0000b426cgHlSPs](https://siebeswart.photoshelter.com/image/I0000b426cgHlSPs)*

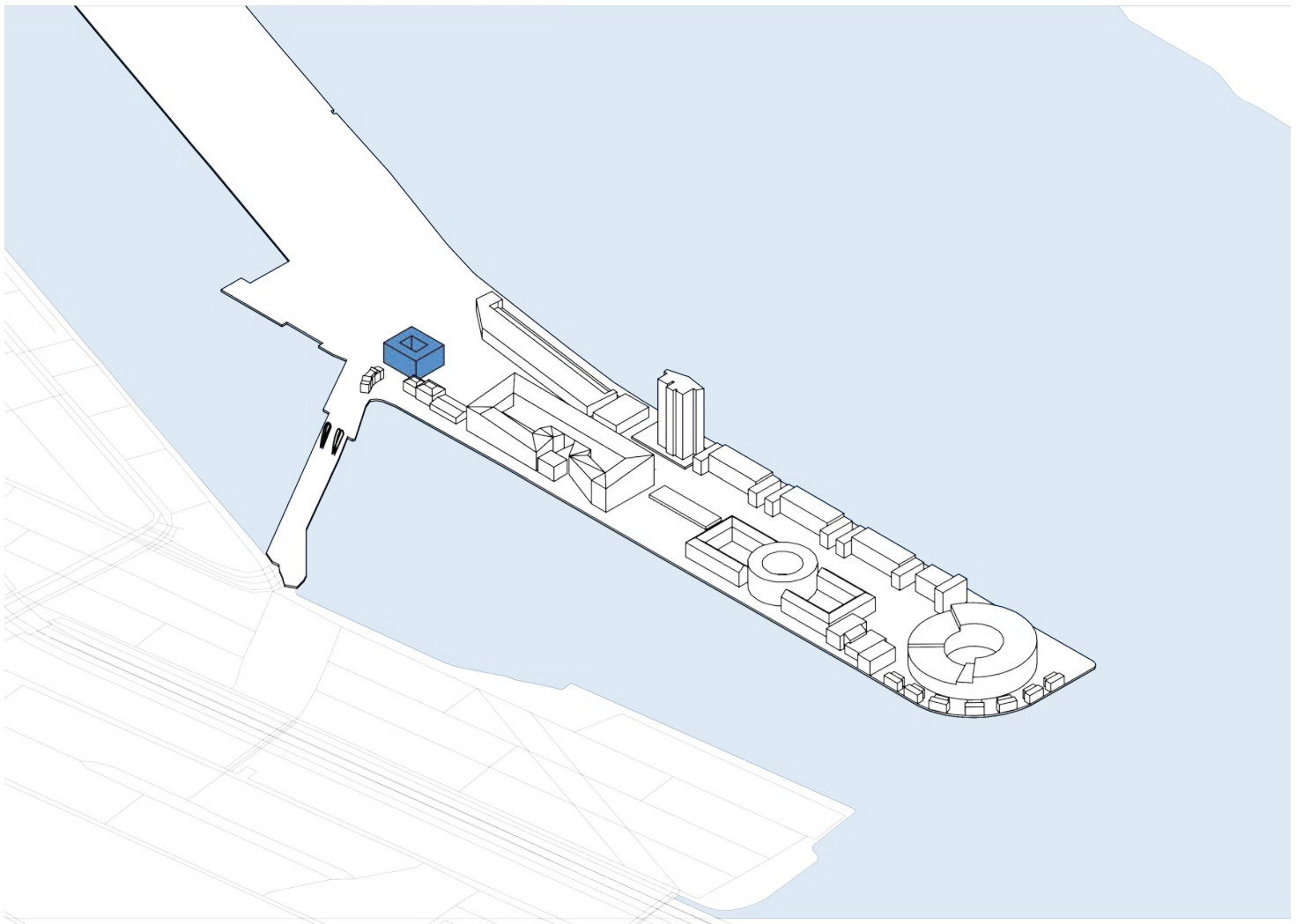



**Take advantage of the location**

Being an isolated elongated island surrounded by water, Jo Coenen, the master planner, efficiently organized the layout of KNSM Island. The new residential town has a central axis with a clearly defined main circulation path. The “super-block” buildings stood on both sides of the road. The long profile of the residential blocks maximized its exposure to the sea, creating a pleasant sea view for the inhabitants. We paid a visit to one of the apartments near Azartplein (the blue block). The floor-to-floor windows fully capitalized the breath-taking water view. Similar to the KNSM Island, Hembrug is also situated between two canals. As an architect, it would be a shame to let the opportunity of integrating water into the design slip by.

*Drawing:  
Axonometric of KNSM Island*

*Photo:  
One of my classmates Sjoerd was standing  
in front of the floor-to-floor window,  
gazing at the water view*





**Maximize the cultural value**

The former KNSM canteen was transformed to a luxurious residential apartment building, with a price of 1.65 million euro due to its heritage. It is a perfect demonstration of how to reflect a monument's cultural value on the market level, through preserving the structural features and integrating the staircase from a ship, as the site area used to be a ship-dock. I was inspired to reflect on the possible ways to maximize the cultural value of a heritage building beyond simply designing a museum.

*Photo:*

*The former KNSM canteen transformed into an apartment building*

*Source:*

*<http://broersma.nl/koopaanbod-vanaf-1500k/object/3400-levantplein-5>*



Initial design principles Jo Coenen

Final Pireaus design H. Kollhoff & C. Rapp

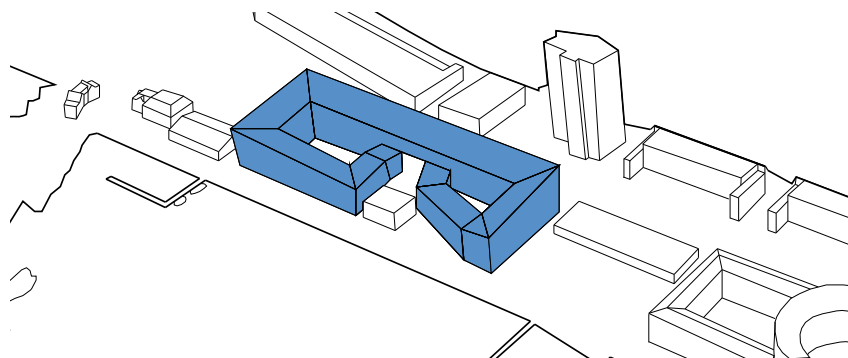
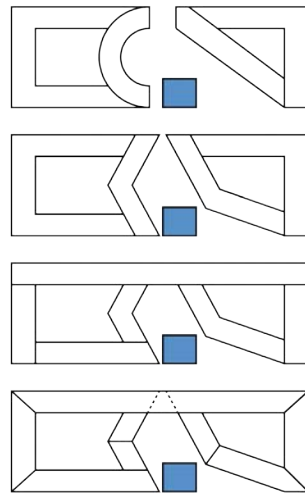
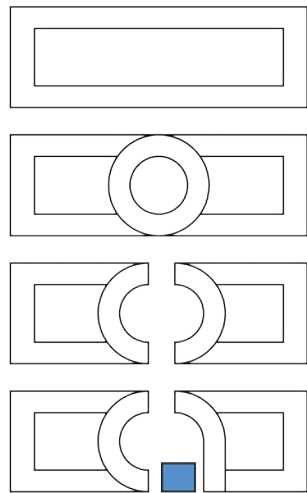



**Maintain coherence, yet maintain flexibility**

The master plan of KNSM Island is filled with massive and bulky buildings of similar sizes. The volume of Pireaus was supposed to be the same with the residential block on Levantkade. In order to adapt the old KNSM office, the building form evolved from its current appearance – embracing the monument. Yet, it is still possible to read the two blocks as one because of their similar size and material. The design not only respects the existing monuments, it also maintains a coherent identity throughout the whole Island.

*Photo:*  
*Building Pireaus*

*Source:*  
<https://www.hagemeister.de/nl/referenties/fassaden-projekte/referenz/knsm-eiland-amsterdam/infobjekt/>

*Illustration:*  
*KNSM Analysis booklet, Heritage and Architecture Graduation studio, 2018-19, p. 57.*





### **Create flexible space**

During the visit, an interesting conversation was made regarding the differentiation of public, semi-private and private space. In my opinion, the ambiguity of the ownership of an open space perhaps is the beauty of what I define as “place-making”. The south quay of KNSM Island is wider than the north quay. On the south quay, the road is used as a pedestrian walkway, parking space, and a private garden at the end of the road as shown in the photo. There is a blurred line between private and public use. Nevertheless, this vagueness creates diversity. To clarify, I am not suggesting that we should delete all the boundaries of public and private space, instead we should create a mediator, flexible open spaces for the city to cater to various ad hoc needs.

*Photo:  
At the end of the south quay in KNSM  
Island*







### **Create an iconic identity**

Jo Coenen placed the circular Emerald Empire at the end of the KNSM Island with several villas surrounding it. He describes them as the “crown and jewels”. The enormous circular building gives a new identity to the Island. On an architectural level, the iconic building serves as a destination point of the central axis (rather than having an open end facing to the water). In terms of urban planning, the building echoes with the Island’s contour. Being able to redesign a place is a great opportunity for architects/planners to reshape the place identity of an area and redefine its role in the city.

*Photo:  
The Emerald Empire at the end of the KNSM Island*



*Projectile workshop*



*Romneyloods*



*Ammunition factory*



*Commander bunker*

*Legend:*

*- - - - Site boundaries for different ensembles defined by students*



## THE HEAD OF THE CAPE

After a week, certain moments of the site visit still lingered in my mind. One of the moment was when I walked to the end of the island. I was enchanted with the peculiar open space framed by the building facades and fence, which directed my sight towards the wide open Noordzeekanaal. I was moved by the unique atmosphere. Yet, with a packed visiting schedule, I had to leave the area reluctantly. When provided with different ensembles for site selection, I chose the ensemble, the Head of the Cape without hesitation.

*Map:*

*The map of Hembrug with six ensembles indicated by red dotted lines, named by students*

The Head of the Cape (Kop van de Kaap) is located at the tip of Hembrug, facing the Noordzeekanaal and the Zijkanaal G. There are four buildings in this plot, a projectile workshop, a Romneyloods, an ammunition factory and a commander bunker.

### **Building facts:**

The projectile workshop is one of the few buildings located at the Head of the Cape. It was built in 1952 with the purpose of manufacturing and examining projectiles. It exceeded its initial purpose and was deployed as a warehouse, a washroom, a garage and a fire station over time.

The Romneyloods is a type of shed that originated from the United Kingdom, initially designed as an emergency shelter during the second world war. The Romneyloods in the Head of the Cape was built in 1980 after the war with a civilian function - storage. The cheap and quick installation reflected the temporary nature of the building that was meant to be demolished within a foreseeable time.

Built in 1958, the ammunition factory is the largest building in the Head of the Cape. Its typical factory typology reflected the industrial era of Hembrug. In the past, cartridges were assembled, painted, measured, inspected and loaded in this building. The building stands out from its surrounding as its orientation falls off from the grids of the neighboring buildings.

The commander bunker, built in 1939, is the only national monument within the site. The bunker is currently filled with water due to rain penetration.

# CULTURAL VALUE ASSESSMENT

	AGE VALUE	HISTORICAL VALUE	INTENTIONAL COMMEMORATIVE VALUE	NON-INTENTIONAL COMMEMORATIVE VALUE	USE VALUE
SURROUNDINGS / SETTINGS	 Dredging depot of De Hem transformed into Hembrug terrain	 Former military ammunition site		 A closed society for workers	 Military defense  Water for transport
SITE	 The bunker was built in 1939. The major factories were built in the 1950s.	 The site was occupied by bunkers in 1941		 The bunker serves as a reminder of the original identity of the area	 Former ammunition assembly, storage and fire brigade  Not accessible Fenced off
SKIN (EXTERIOR)	 Original facade	 Typical Dutch brickwork		 Typical typology for that period	 Defensive use of the bunker  Skylight from the north  Large door for logistics
STRUCTURE	 Original structure	 Structure as architectural element		 Typical typology for that period	 Defensive use of bunker against air bomb  Steel construction for building 421
SPACE PLAN		 Bunker used to follow the shape of the island			 Enclosed open space and zone  Continuous interior  Grid columns
SURFACE (INTERIOR)		 Exposed structure			 Different material surfaces for different functions
SERVICES	 Original lights, heater and washing basins	 Services remind former functions		 Services remind former functions	 Exposed services for easy maintenance  Insulation  Former washing room, garage and fire brigade
STUFF	 Old fire truck	 Old fire truck			
SPIRIT OF PLACE		 Sense of productivity			



NEWNESS VALUE	RELATIVE ART VALUE	RARITY VALUE
		
	 	
	  	
		
		
	 	



This week a workshop was held on the assessment of Hembrug’s cultural value. From understanding that a heritage can embody many different values, it is critical to list out all of them and assess them independently, so that no values will be lost during the design phase.

On the left column of the matrix , all building elements were divided according to different building layers as described by Stuart Brand.<sup>1</sup> A new element was added, “spirit of place” to acknowledge and evaluate the zeitgeist of Hembrug. On the top row different categories of values that is embedded within a building or place were listed.

The red color indicates the items that has a high value. Yellow means the evaluated item is indifferent to our consideration. Green color stands for the least value or even negative value.

Source:  
 Kuipers, Marieke, and W. De Jonge. *Designing from Heritage: Strategies for Conservation and Conversion*. Delft: TU Delft - Heritage & Architecture, 2017.

CURVED LIGHT REPEATED  
CURVED LIGHT REPEATED  
CURVED LIGHT REPEATED  
CURVED LIGHT REPEATED

CONNECTED CONNECTED CONNECTED CONNECTED CONNECTED



## BUILDING CHOICE

Among the four buildings in the Head of the Cape, I was most attracted to the ammunition factory due to its very peculiar typology that stands for the zeitgeist of its time. I extracted the building characteristics that I valued the most to compose an illustration of the building profile. The curved shell roof is a common feature of the factories in that period with the aim to facilitate ventilation. It also has a great potential for increasing thermal comfort and in providing sufficient day light levels without artificial lighting. I find the aesthetics inherited in the overall building shape to be very rich. However, this representational element may be an obstacle for design as the concrete structure is very rigid, the plan is occupied by a fixed number of columns.

*Illustration:  
Using extracted characteristics of  
the ammunition factory to create a  
simplified facade outline*

POCKET GREEN SPACE



PEACEFUL



VIBRANT

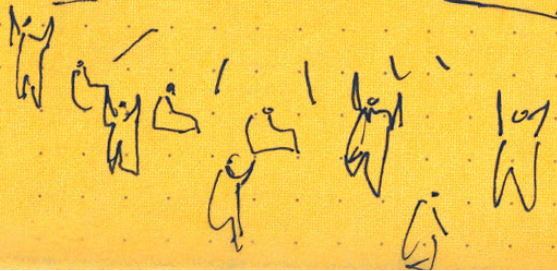
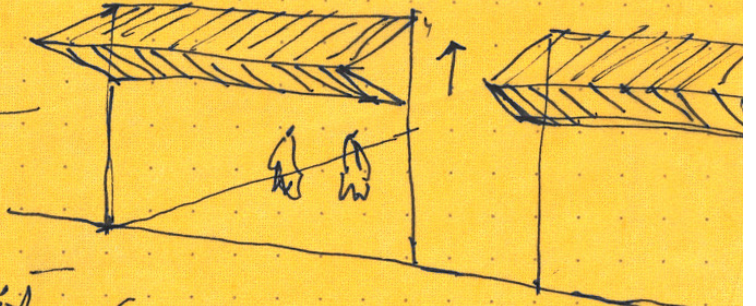
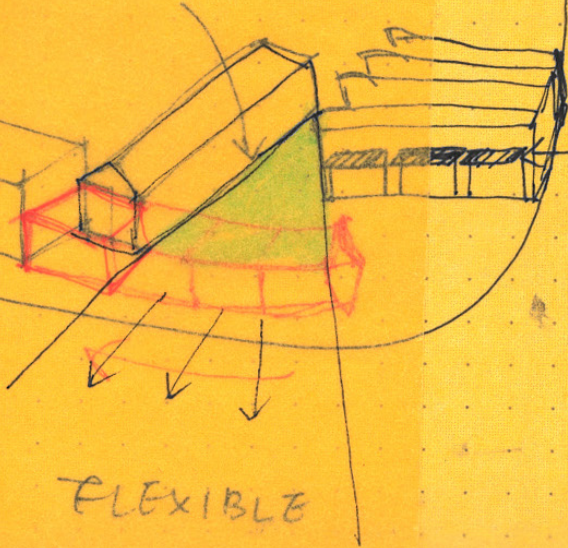



Inspired by the historical presence of the bunkers in 1941 built by the Germans at the Head of the Cape, I tried to capture the history and transform it into a building which can accommodate events and activities that are relevant in today's society. I was inspired create a diverse atmosphere in both the day and night. People can enjoy a cup of tea inside the ammunition factory in the morning while events or performances could be held at night. The new mass on the left of the sketch appears to stem from the long iconic bullet factory. Together, they strengthen the edge of the waterfront.

*Sketch:  
Inspired by the historical presence of a  
strip of bunkers in 1941*

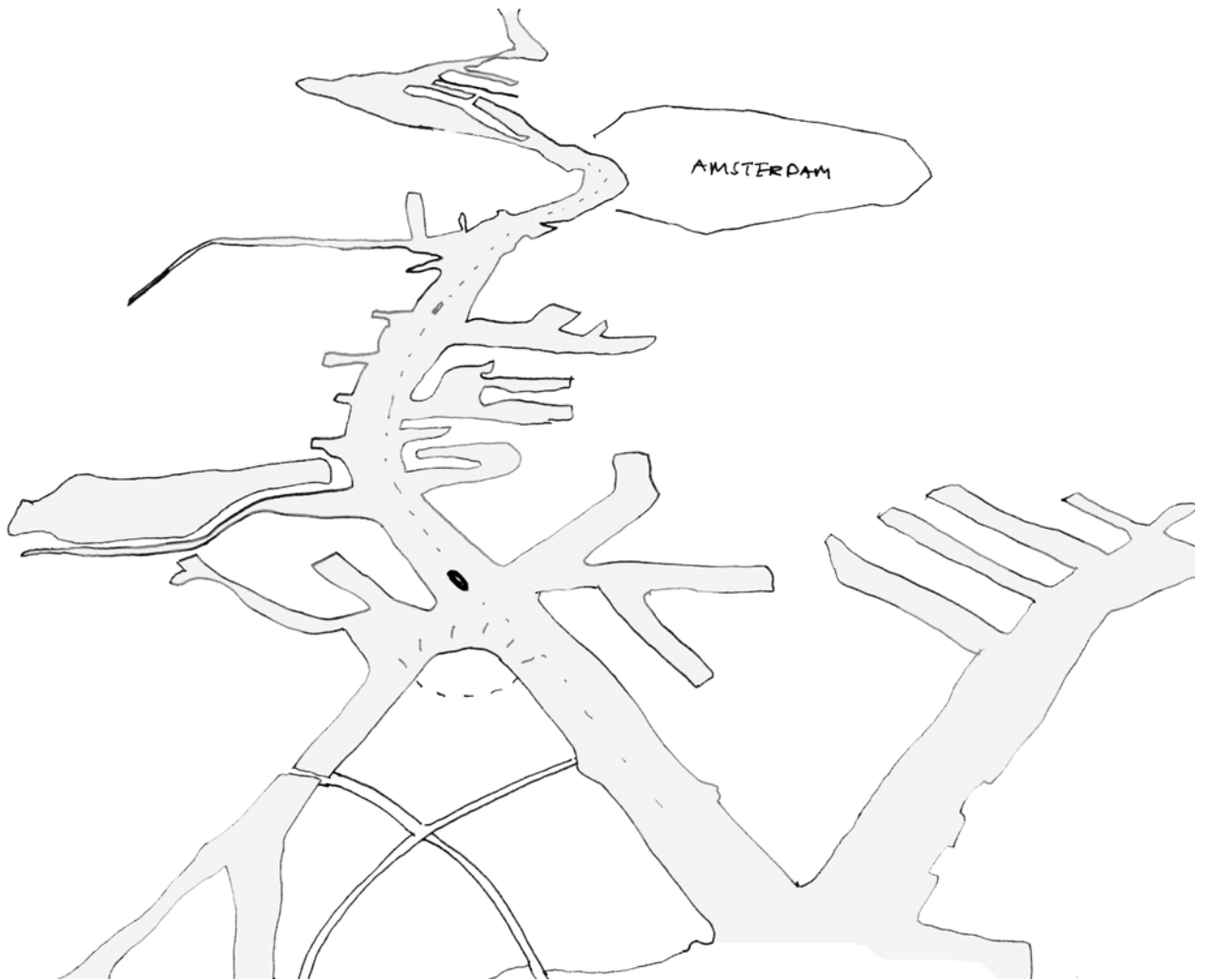
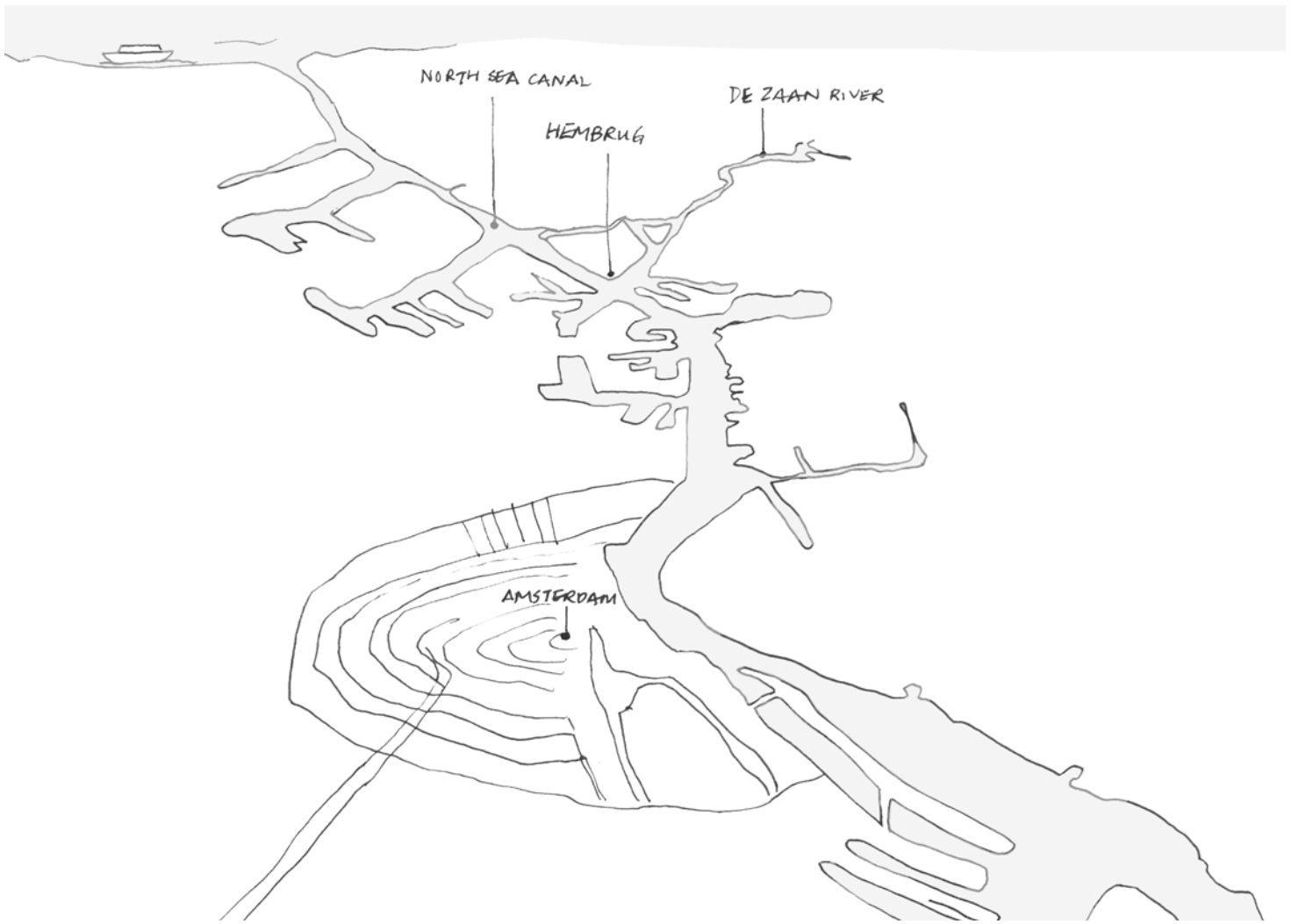



## PALMBOUW LECTURE

I had a lecture given by the Palmbout Urban Landscape this week. The speaker pointed out that both Zaanstad and Amsterdam are expanding due to a significant pressure in the housing market. To meet the foreseeable demand, the Amsterdam municipality planned to build 300,000 new houses by 2040. This is a huge urban development project which requires certain amount of amenities and public transportation to cater the needs of future inhabitants.

At the tip of Hembrug, where the Noordzeekanaal and Zijkanaal G come together, the Head of the Cape is highly visible from the neighboring areas. It is without a doubt that Hembrug will become a new landmark by the water front.

*Source:*

*Palmbout Urban Landscape, Beeldkwaliteitsplan Hembrug-terrein, 2011.*

*Top sketch:*

*Perspective from Amsterdam*

*Bottom sketch:*

*The Head of the Cape is highly visible from the neighboring area.*

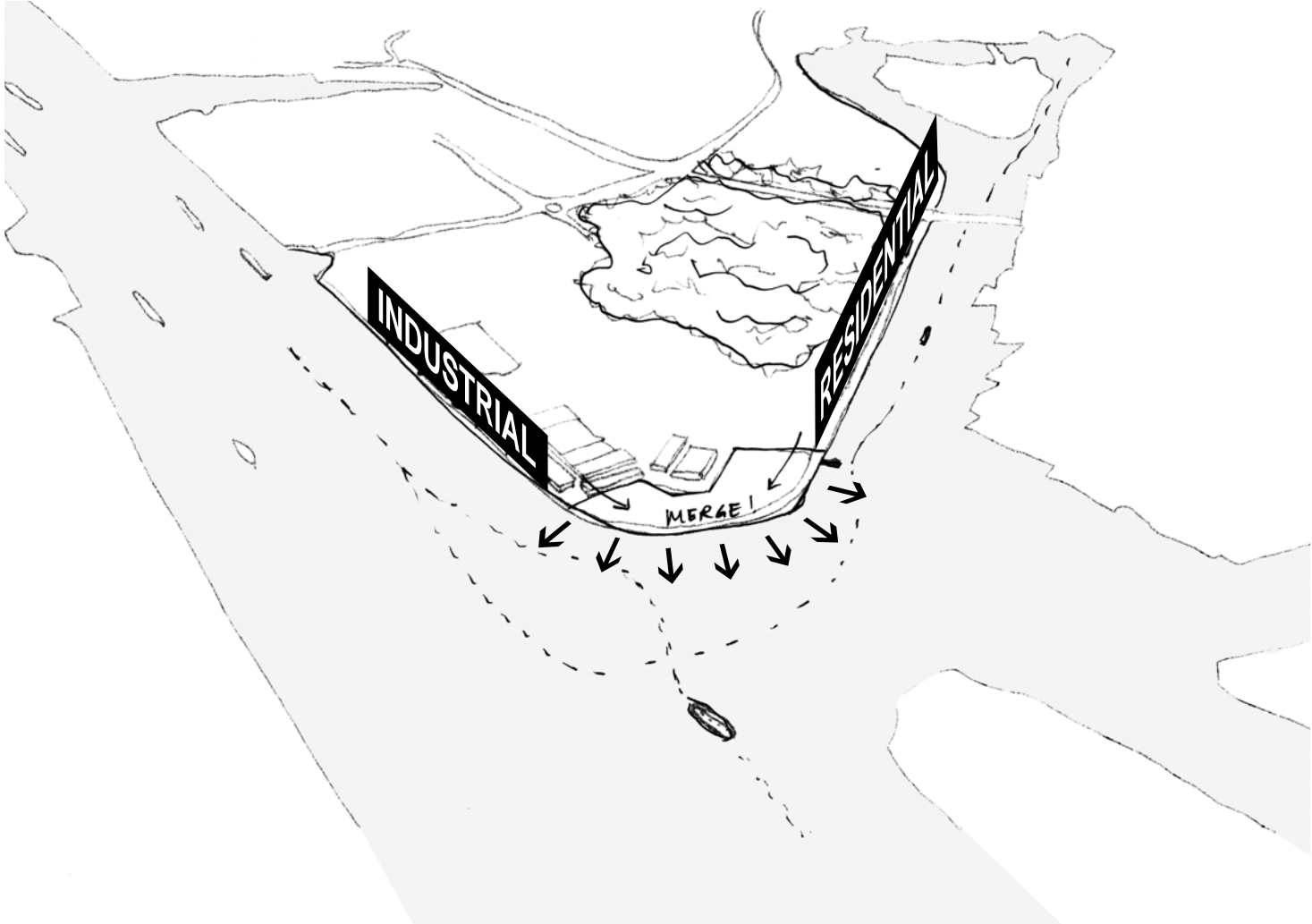



# ROLE OF THE CAPE

## Role of the Cape

1. Bring together industrial and residential waterfront
2. Connect the shore and water
3. Coexist with the surrounding
4. Activate Hembrug redevelopment
5. Fulfill residential needs

## *Sketch:*

*The Head of the Cape has to bring together the industrial and residential fronts of Hembrug*

## Suggestions

- Common programs shared by the two areas
- Common public space
- Paths to connect the two areas
- Create sight line between shore and water
- Improve water transports
- Extend paths towards water
- Extend water into shore
- Build continuous or similar mass
- Similar materials
- Connect with the water
- Improve accessibility, function and sight line
- Accommodate housing

Given the projected development of Hembrug, and its prime location defined by its clear visibility at the waterfront, the site calls for a grand gesture - a cultural landmark. The aesthetics should capture the history of Hembrug through careful structural design and material selection that represents the Zeitgeist of the 1950's, the most predominant era of Hembrug. It should also at the same time stand as a beacon for the future of what Hembrug will become, accommodating for cultural activity, formal events and a central communal space for the social integration of Hembrug's community.

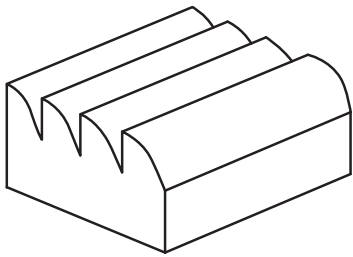

Minimal Changes

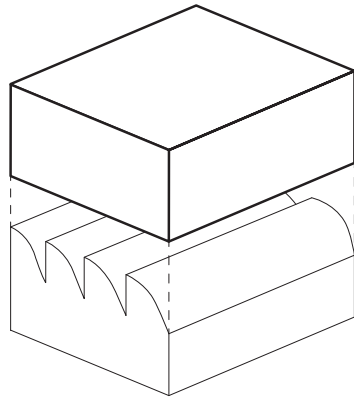

Add On

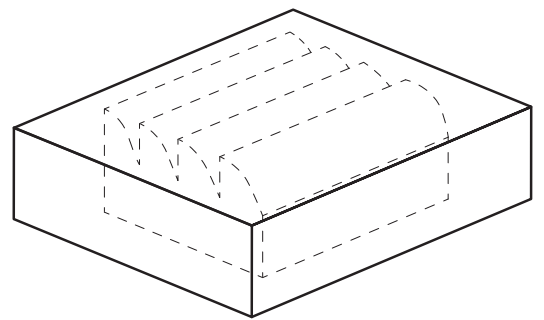

Reinterpretation



## MASTER PLAN OPTIONS

This week, we have come up with three options for the redevelopment of existing buildings. The first is to keep the existing building with minimal interventions, the second is to add a new volume to the existing building and the third is in demolishing the existing buildings to give way to a new design that represents the history but at the same time accommodate for future activity. We have drafted a few master plans for these three scenarios.

*Illustration:  
3 options for the redevelopment of  
existing buildings*

KEEP ORIGINAL MASS

+ HISTORICAL PATH





# MINIMAL CHANGES

## Pros

- Cater residential and commercial needs
- Building facades open to water
- Improve accessibility
- Connect green space
- Link separate buildings with a historical path
- Public, vibrant Cape South and private, tranquil Cape North

## *Sketch:*

*Master plan with minimal changes*

## Cons

- Possible problems with new pier
- Unsustainable to demolish the projectile workshop
- Lack of private outdoor space for residence

The first option is to have as little interventions as possible. The idea is to keep most of the buildings (except for the Romneyloods) and to create a path for visitors to experience the buildings with a defined route. My preference is this option. This master plan depicts a scenario of a future community in the Cape. The program is a good mix of residential, commercial and public use. All these functions are linked with a theme, a historical path which connects the three buildings together. The meandering route guides the visitors from the road entrance in Middenweg to a market which is transformed from the old projectile workshop. The steel structure will be kept, with the addition of a new roof. The new market will have a tent-like structure. It creates an open, welcoming gesture for the visitors. The open market idea is compatible with OMA's design of the art exhibition center. The market can be an extension of the covered square when there is an exhibition or event. The route will then lead to the ammunition factory which will be transformed into a mall with different retail shops. The original structure will be kept to remind people the former identity of the place. After exiting the mall, visitors will discover the monument, the bunker on their right with a closer look. Finally, the route brings people to the new residential area. The two residential blocks are laid along the edge of Side Canal G. The second row of the housing is higher than the first row, so that more residents can enjoy a view of the waterfront. The route ends at the old pier where visitors can also start the tour from here.

# ADD-ON OPTION 1

+ CONNECT TWO EXISTING BUILDINGS

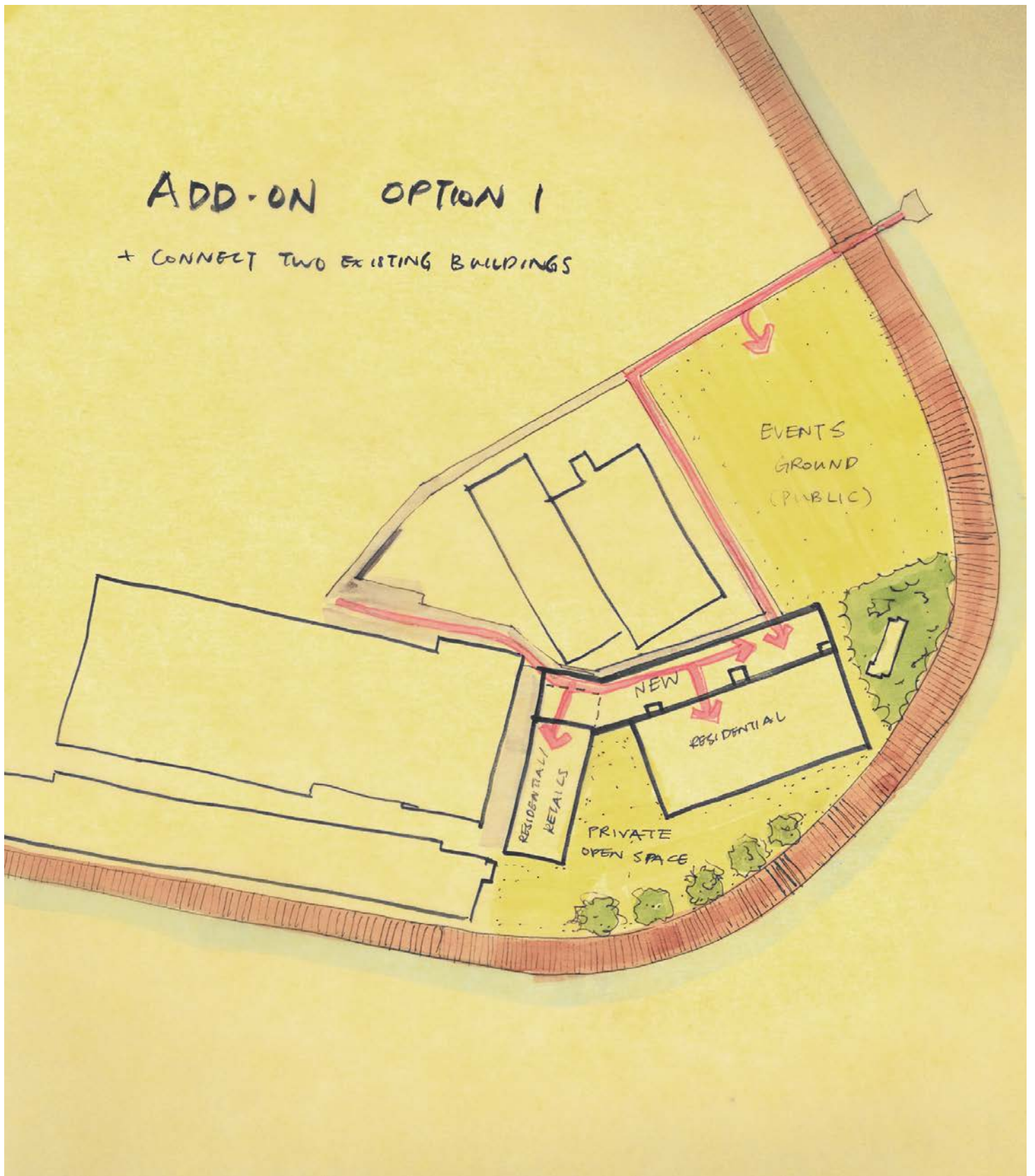

# ADD ON

## Pros

- Cater residential and commercial needs
- Building facades open to water
- Link separate buildings with a new mass
- Improve accessibility
- Defined green space for private and public use
- Keep the commander bunker hidden

## *Sketch:*

*Master plan with additional massing option 1*

## Cons

- Insufficient housing
- Have to demolish part of the projectile workshop
- Low utility rate for event ground



ADD ON OPTION 2

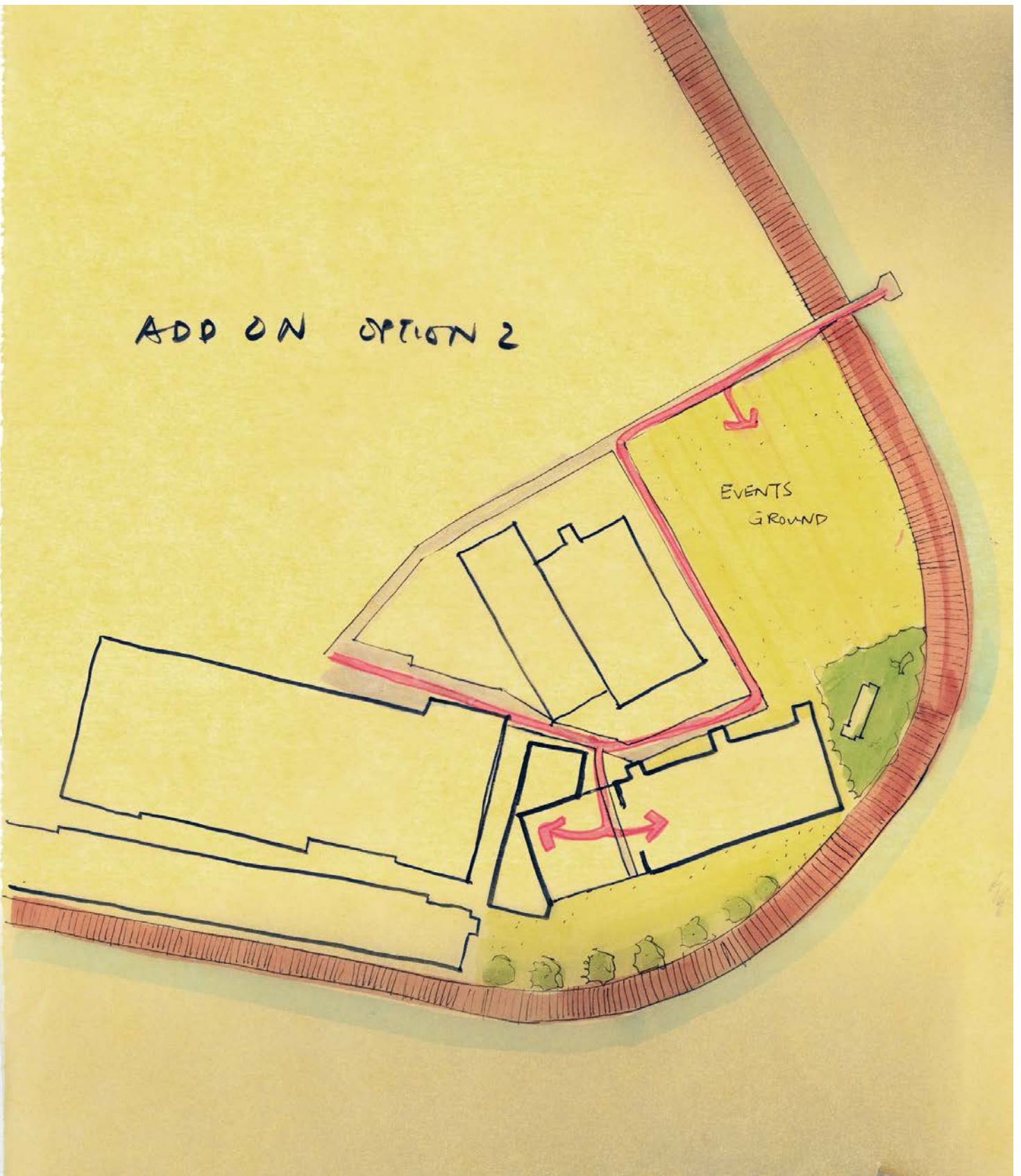

#### Pros

- Cater residential and commercial needs
- Building facades open to water
- Link separate buildings with a new mass
- Maintain mysterious character
- Defined green space for private and public use
- Keep the commander bunker hidden

#### *Sketch:*

*Master plan with additional massing  
option 2*

#### Cons

- Insufficient housing
- Have to demolish part of the projectile workshop
- Difficult connection details
- Low utility rate for event ground



# REINTERPRETATION

+ HALF FOREST, HALF BUILT

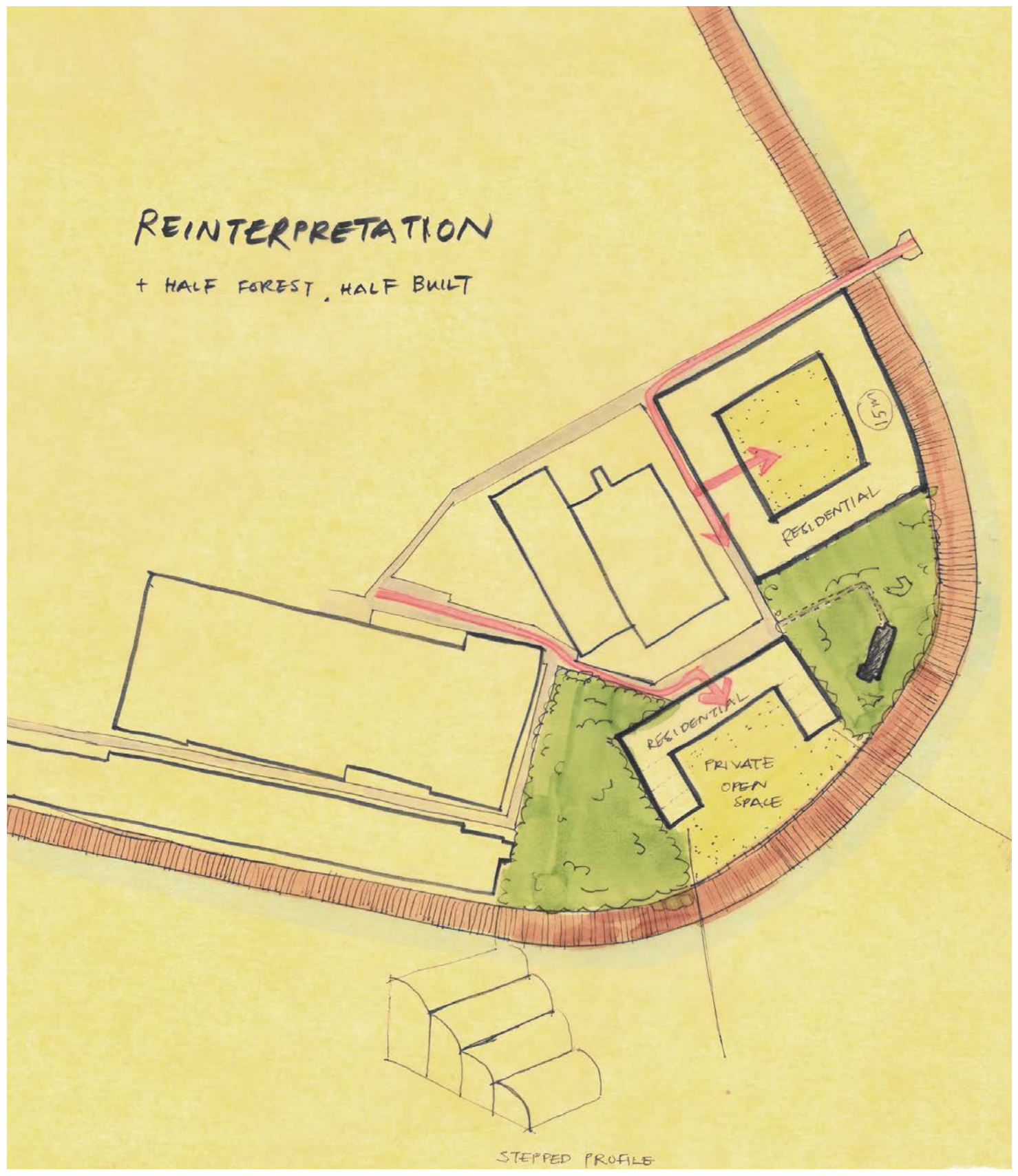

STEPPED PROFILE



# REINTERPRETATION

## Pros

- Cater residential needs
- Maintain mysterious character from inland
- Half green, half built
- Provide private outdoor area for residence
- Provide exploration for visitors to discover the bunker

## Cons

- Lack of public open space
- Incompatible with OMA's design

## *Sketch:*

*Master plan with reinterpreted historical form and typology*

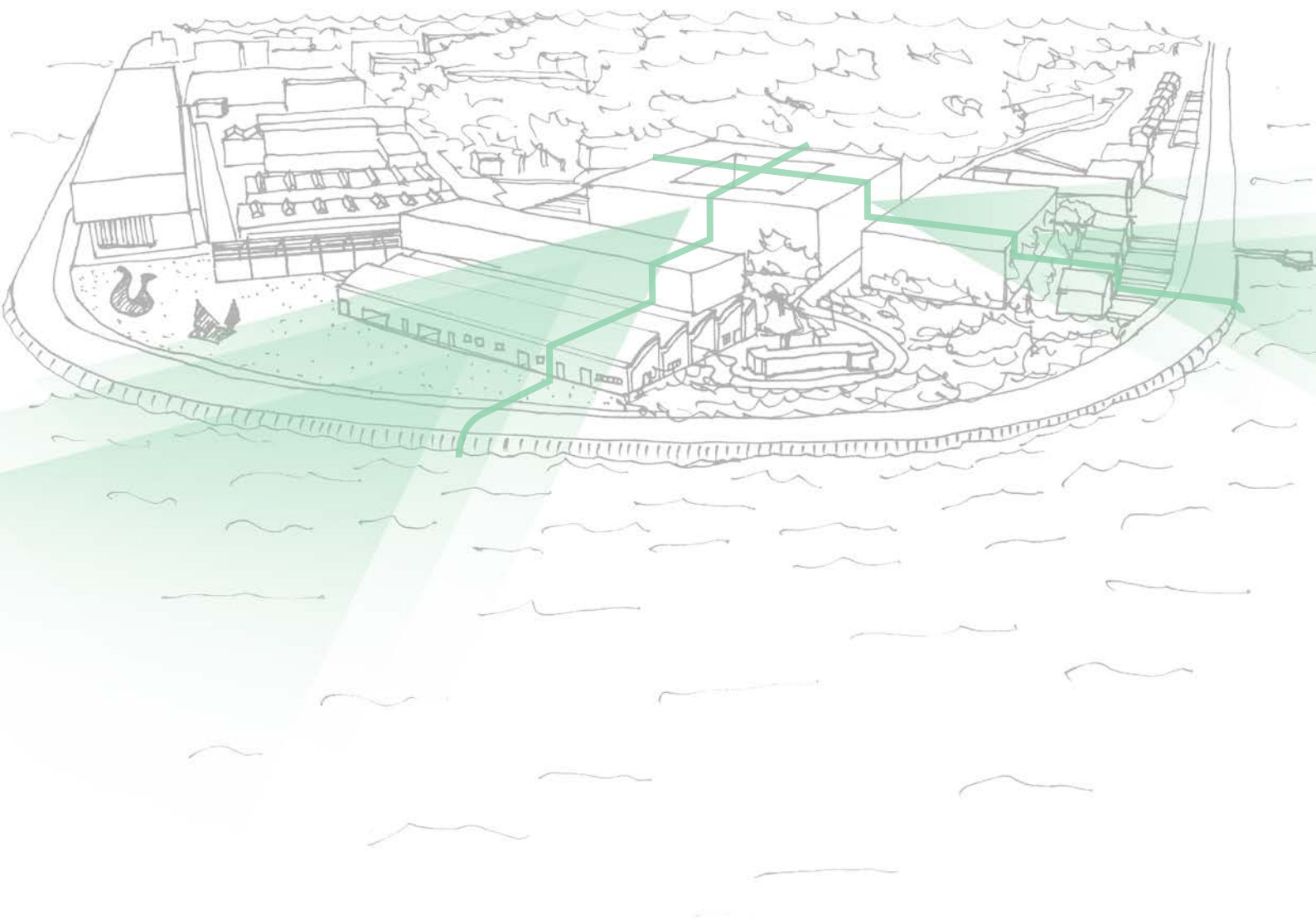

# SKETCHED SCENARIOS

## **Stepped profile of the Cape**

The residential area is laid out in three layers, the villas in the first row along the waterfront, the hotel and parking facility in the middle as well as a residential block at the back. The stepping profile allows more residents to enjoy the water view. There will be a new add on above the ammunition factory for extra residential units.

*Sketch:  
Scenario of an overview of the Head of  
the Cape*



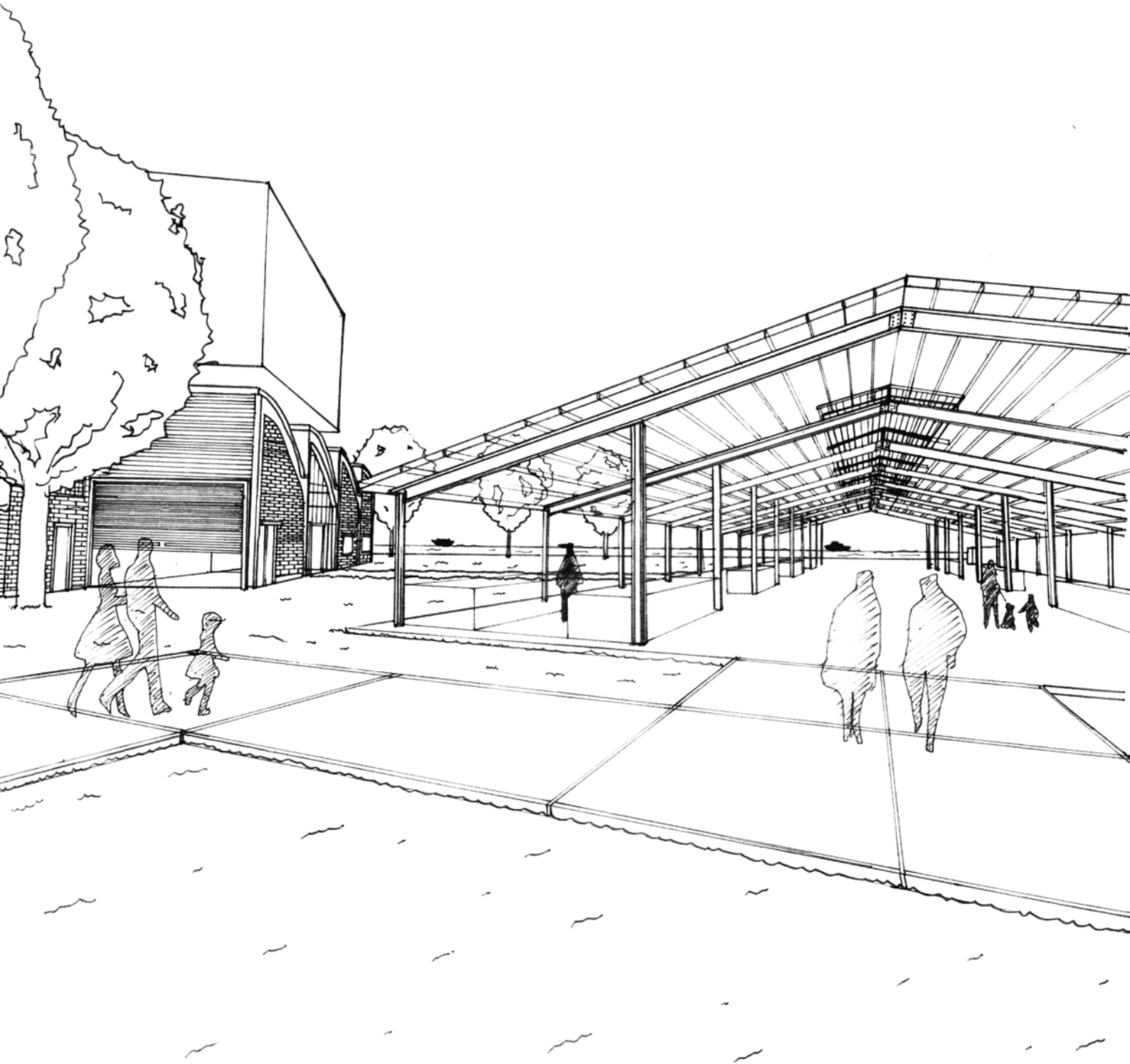

### **Open market as a welcoming entrance**

This sketch shows the perspective at the end of the main road. The projectile workshop will be transformed into a market with an open plan. Brick facade, partition walls will be taken down to create an inviting and welcoming gesture for visitors. Only the existing steel structure will be preserved.

The market sells vegetable and fruits during the day and turns into an extended event ground for the art and cultural center (building 429) at night. The idea of the transformation is to make the building open, transparent and flexible.

*Sketch:  
Scenario of an open structure transformed  
from the projectile workshop*

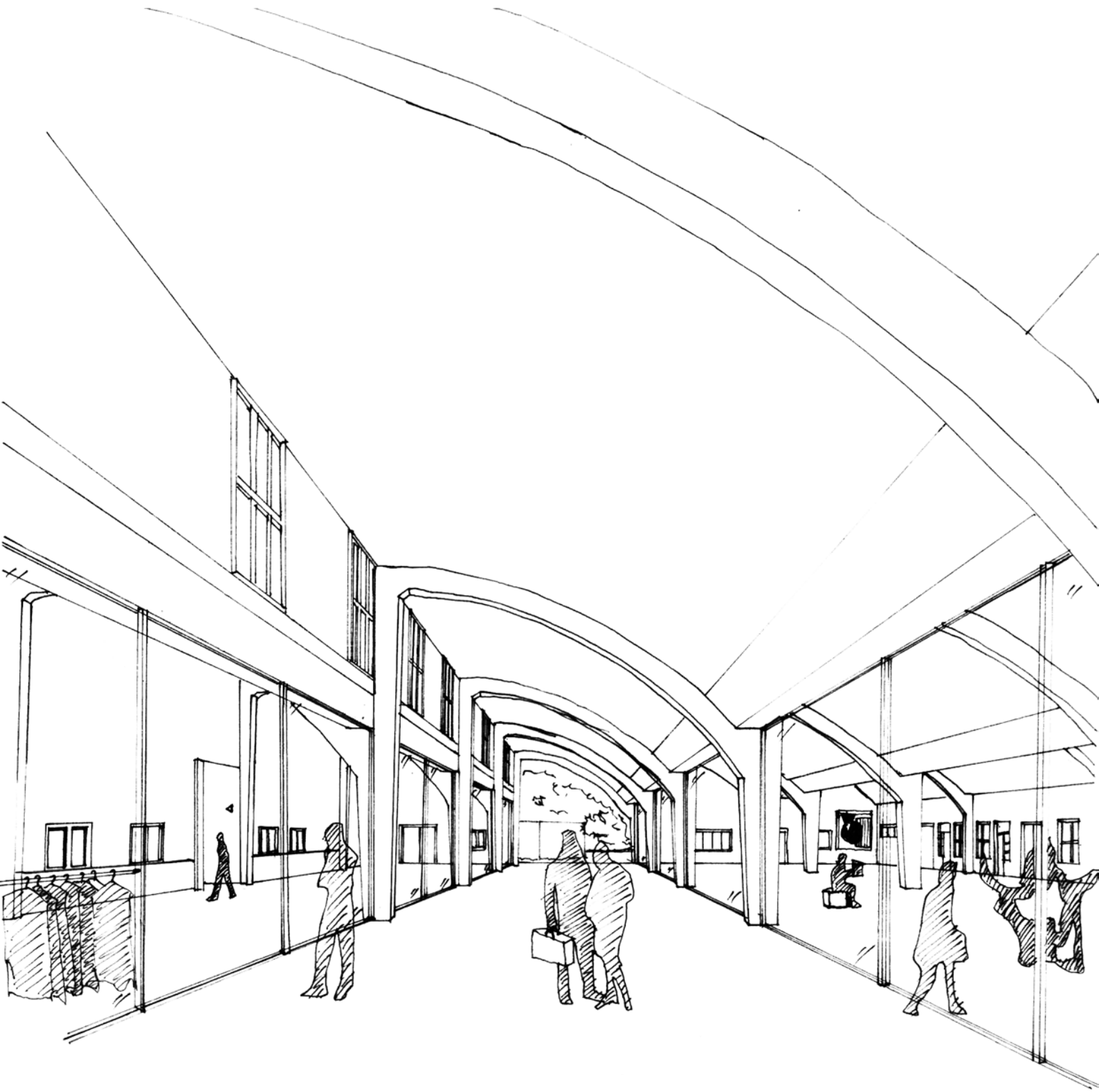



### **Visual connection of the ammunition factory and bunker**

The ammunition factory is made of repeated curved concrete frames, brick infill walls and four concrete roof. The building can be perceived as four consecutive long tubes. In the sketch, the building is transformed into a mall and exhibition space. The east and west facades of one of the aisles are demolished. This creates a long corridor throughout the building. The visitors can see the bunker surrounded by woods at the end of the corridor.

*Sketch:*

*Scenario of the refurbished interior of the ammunition factory*

# MODEL MAKING

Existing situation



*Figure 1. 1:1000 site model*

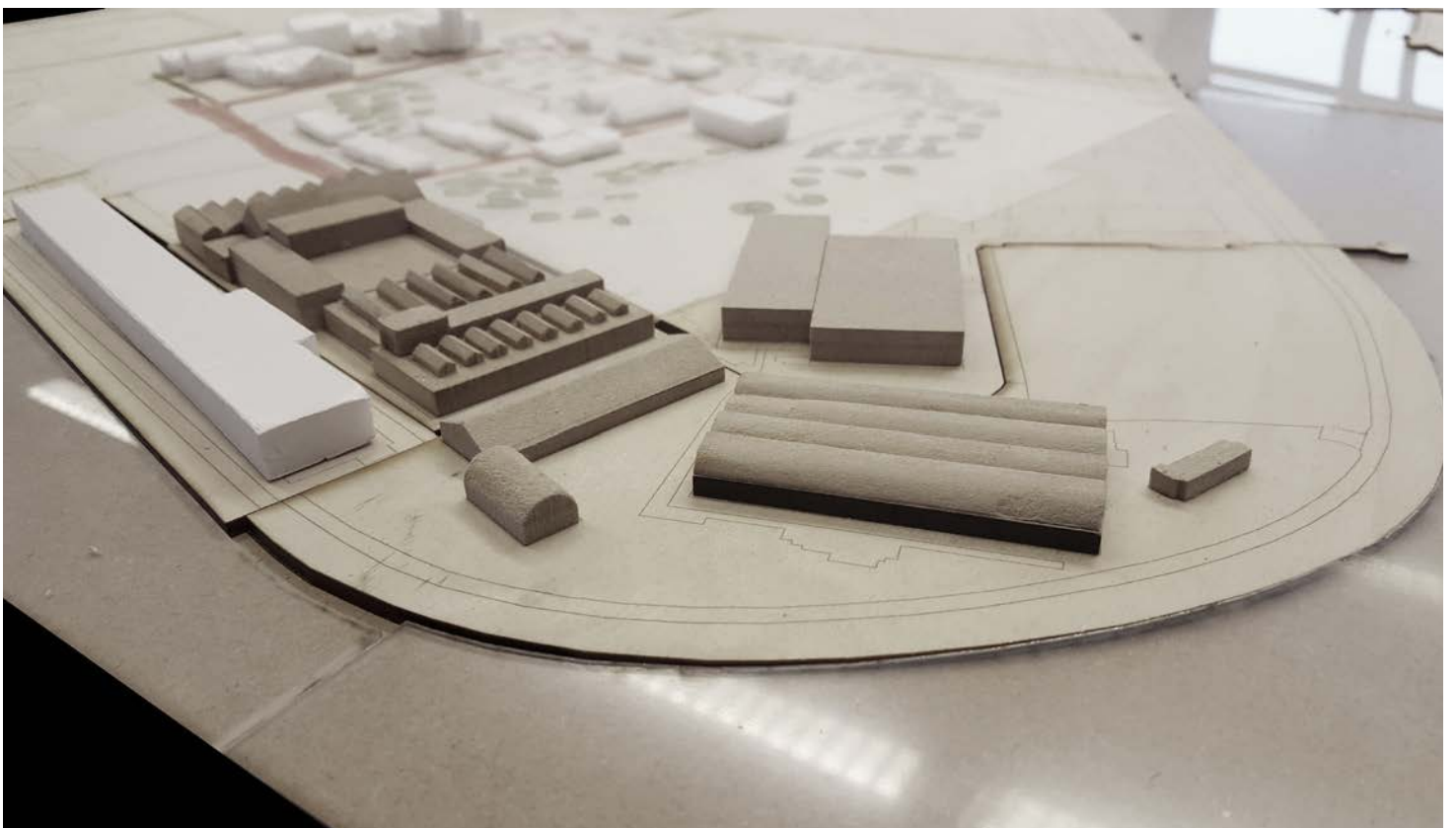

*Figure 2. 1:1000 site model*

Proposed situation

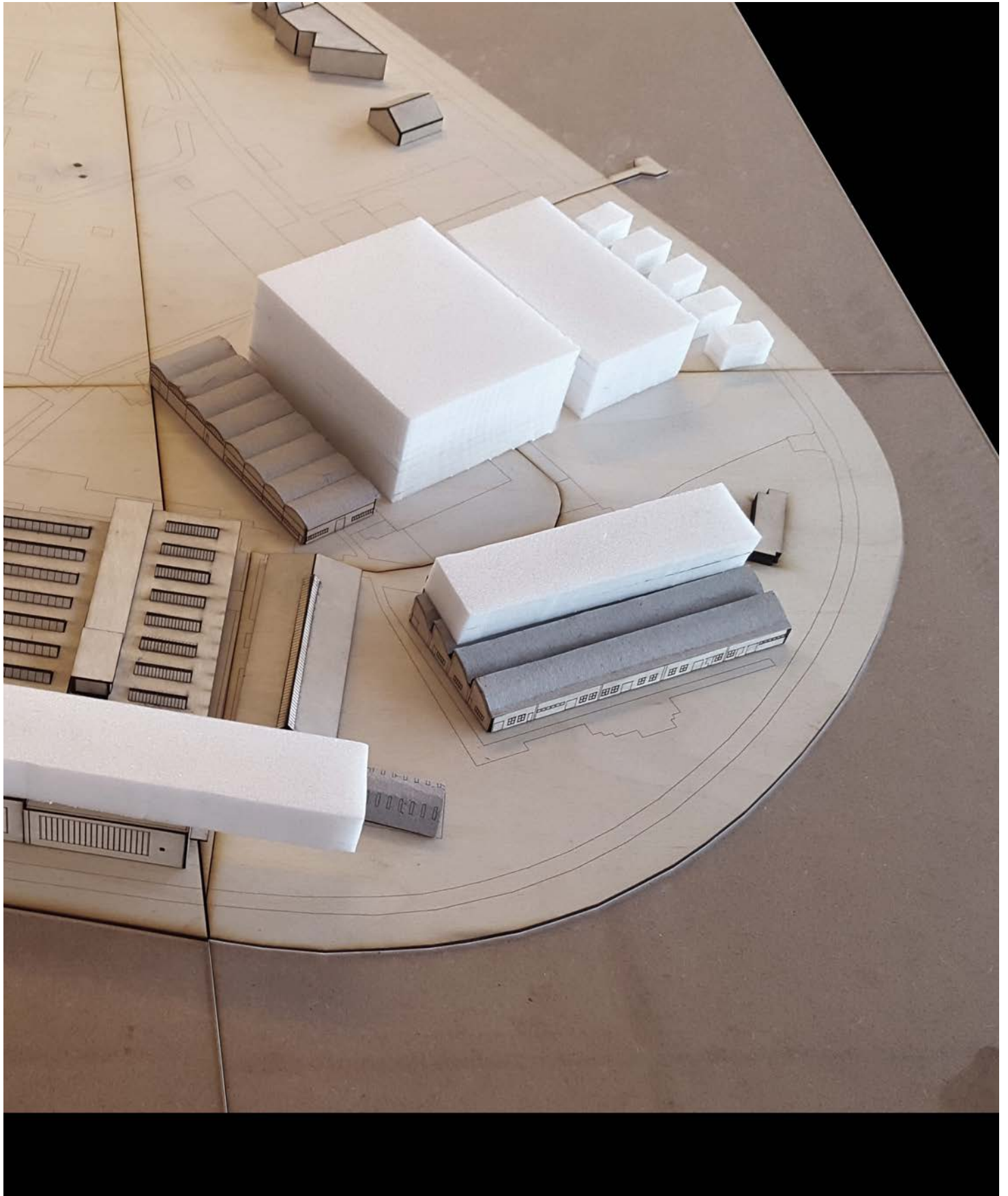
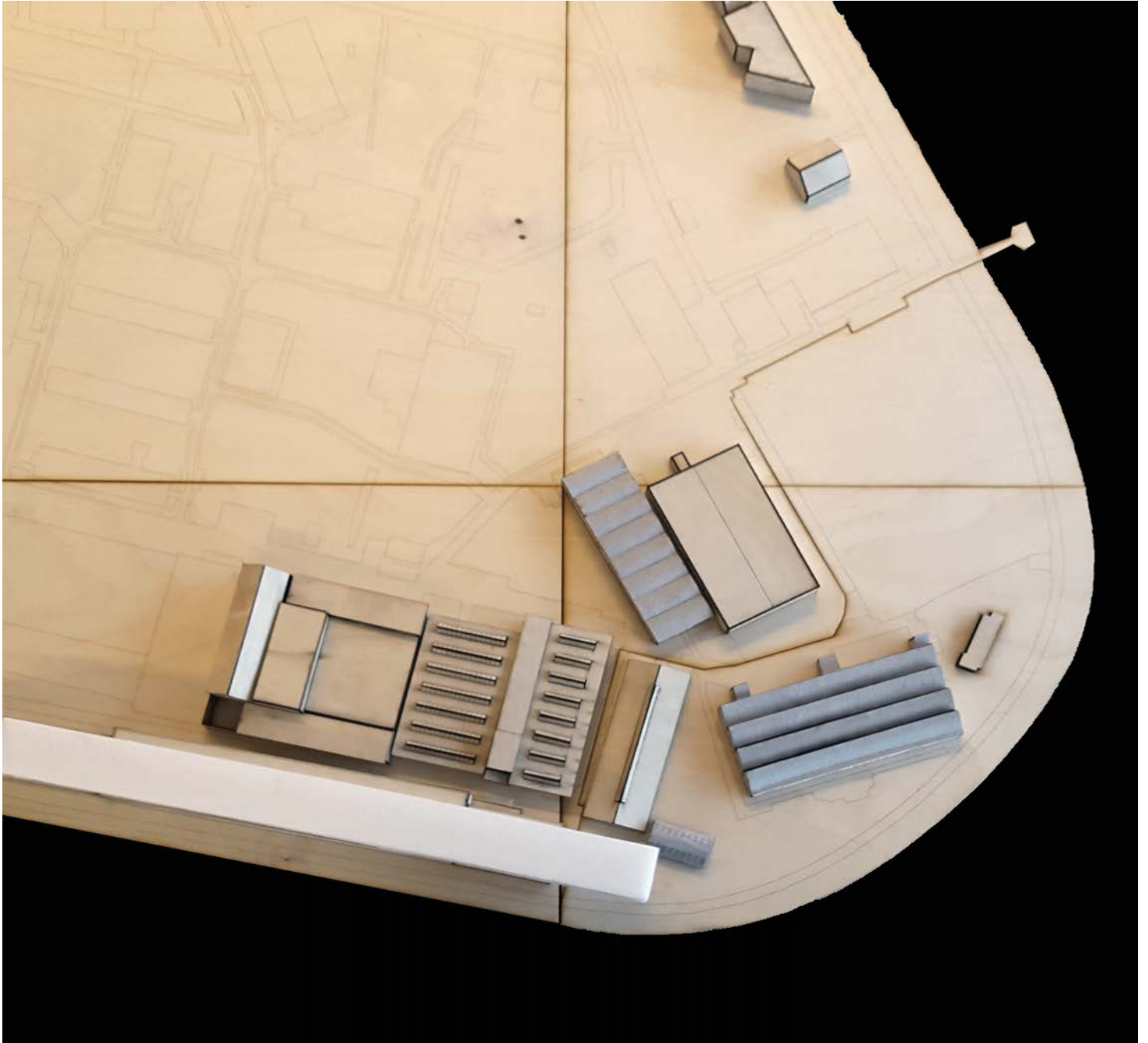

Figure 3. 1:500 model



Existing situation



*Figure 4. 1:500 model, existing condition*

Proposed situation

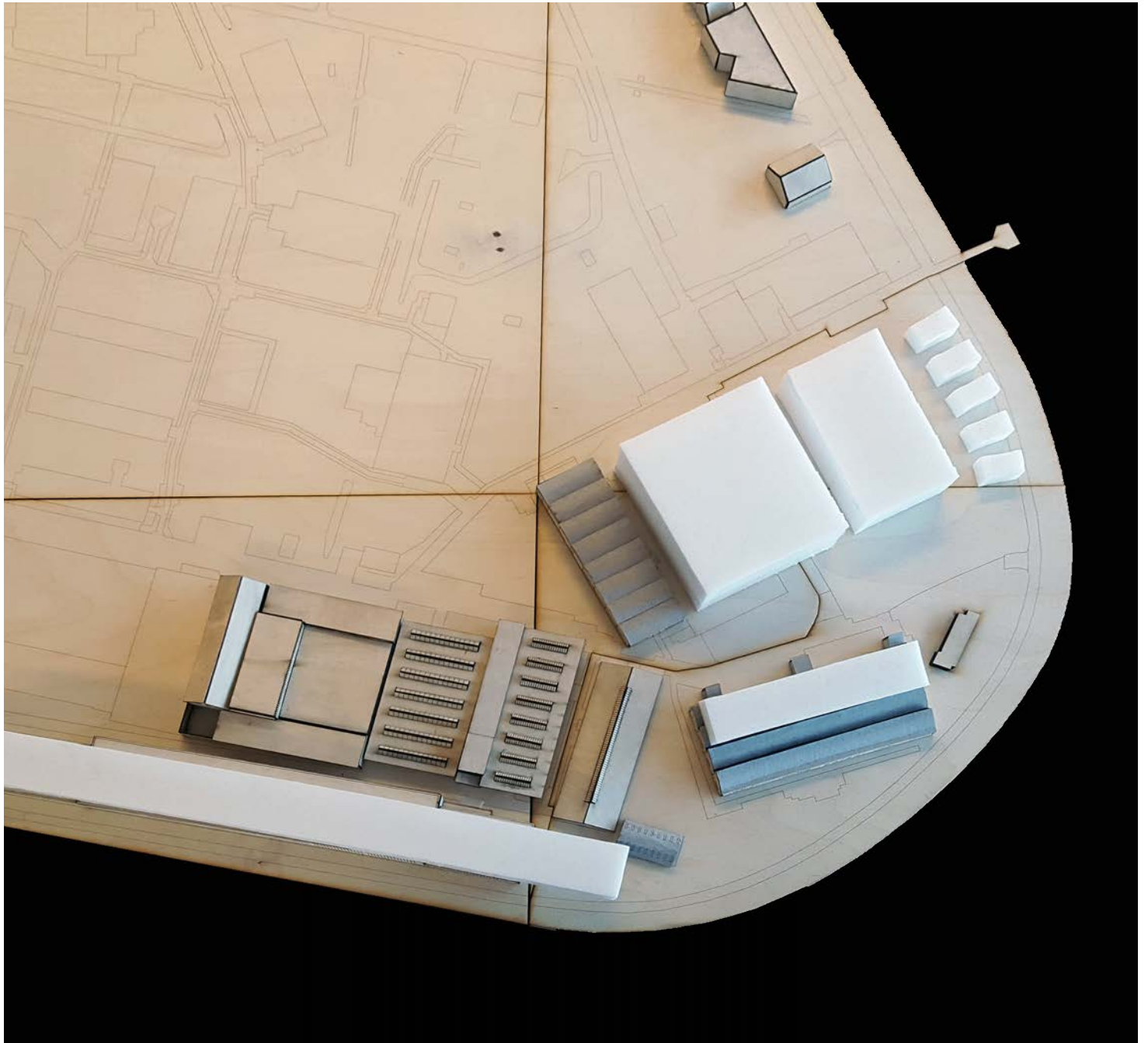
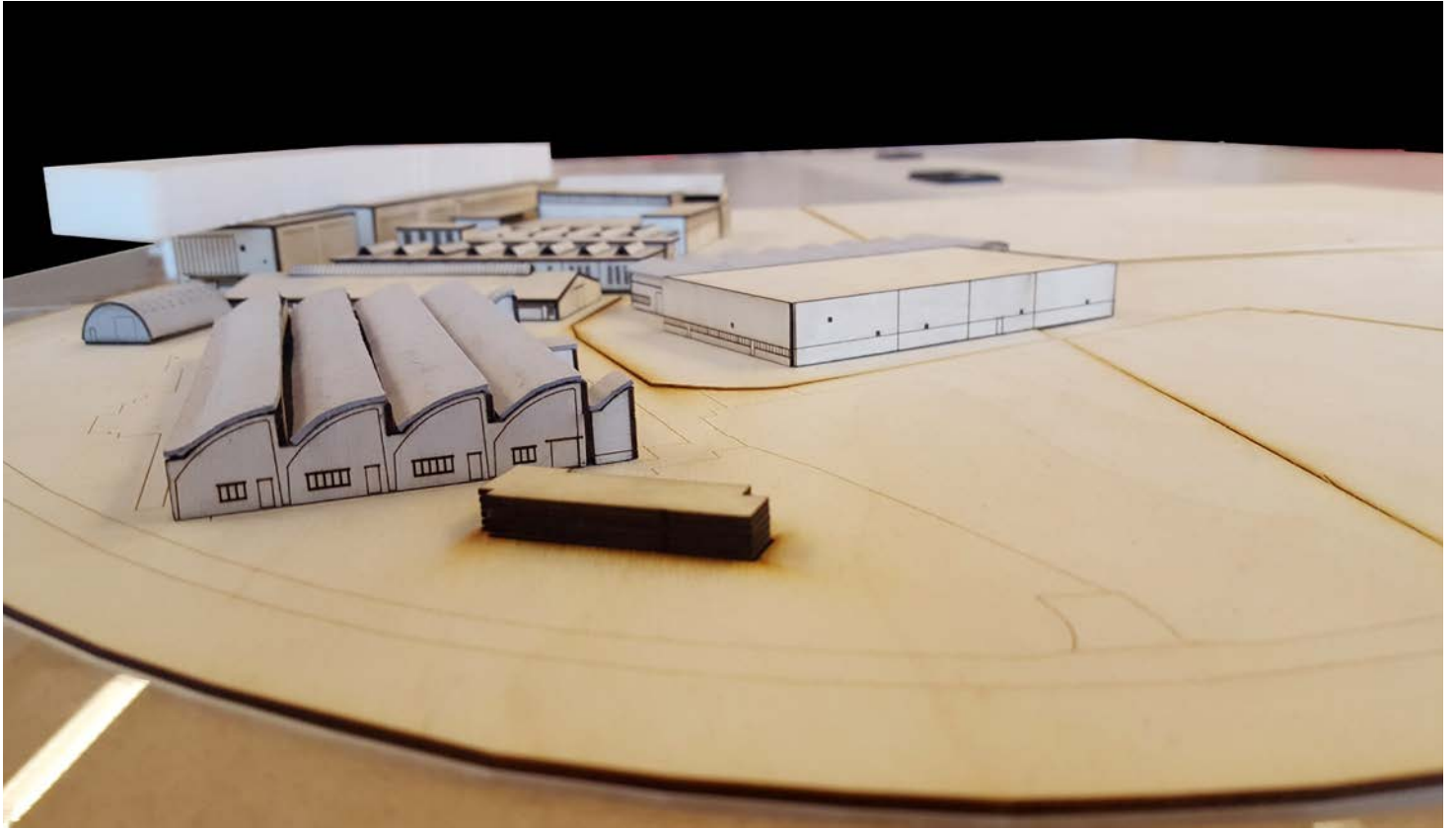
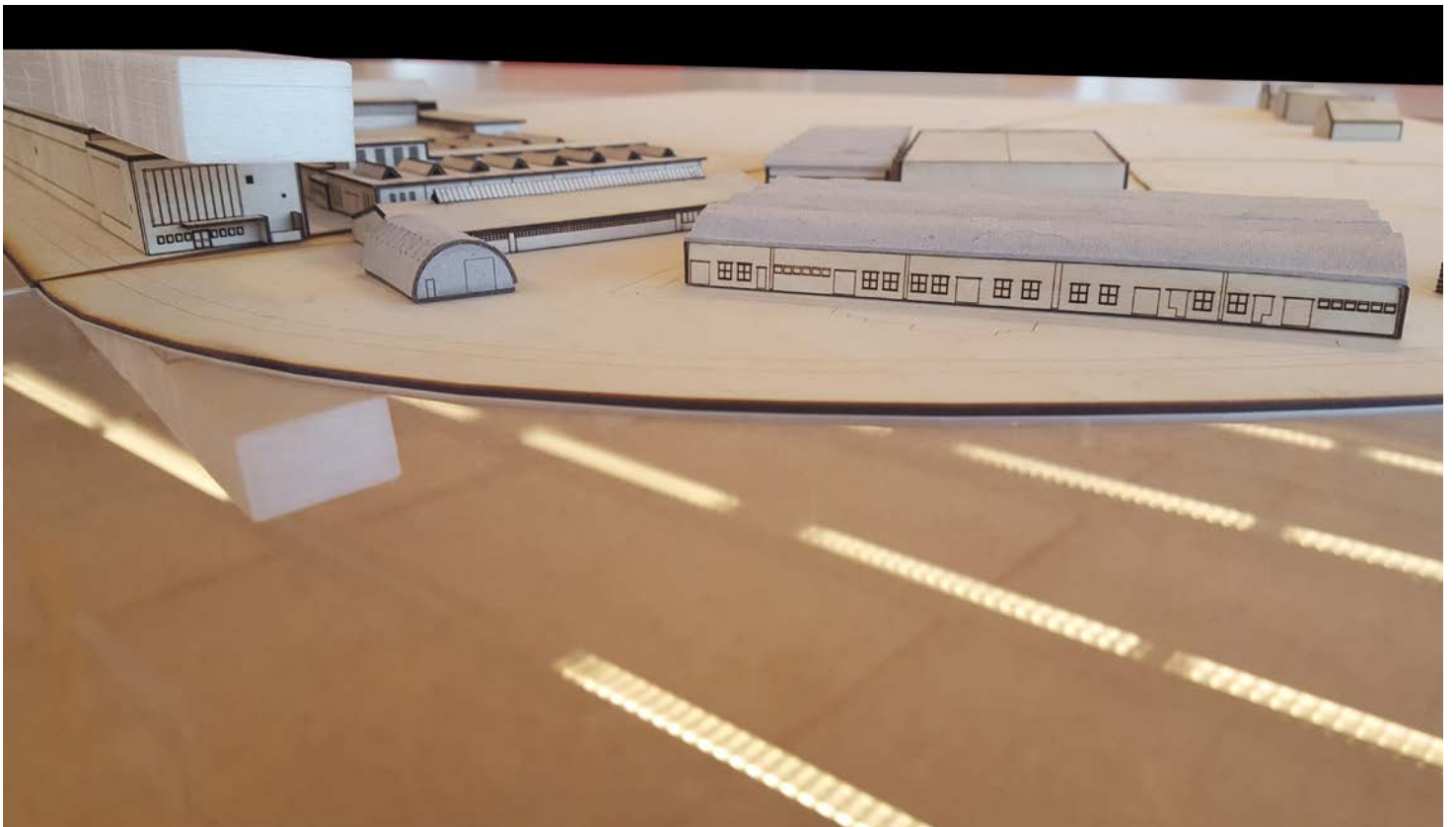

Figure 5. 1:500 model with the new masses

Existing situation



*Figure 6. 1:500 model, existing condition*



*Figure 7. 1:500 model, existing condition*



Proposed situation

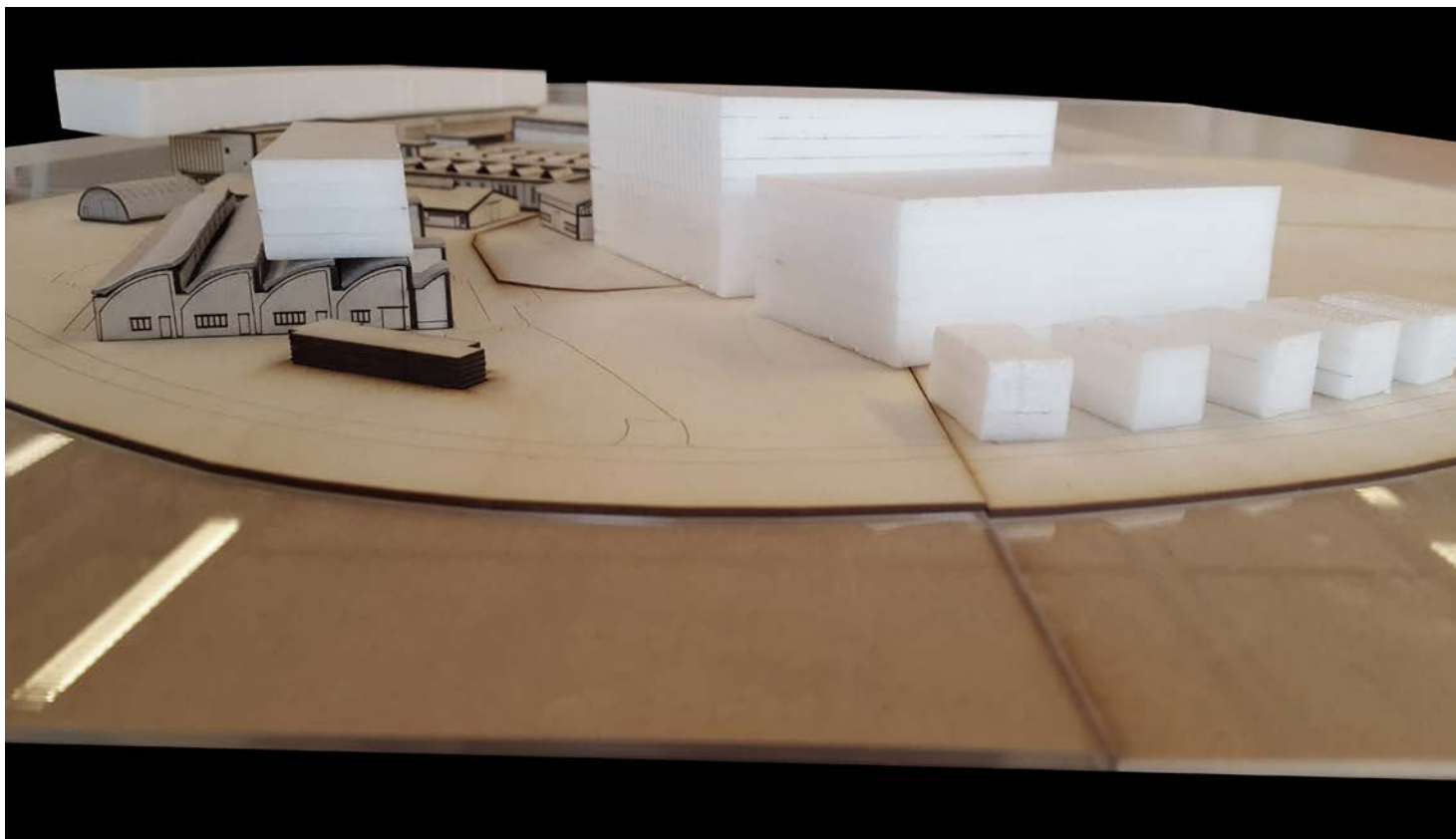

Figure 8. 1:500 model with new masses

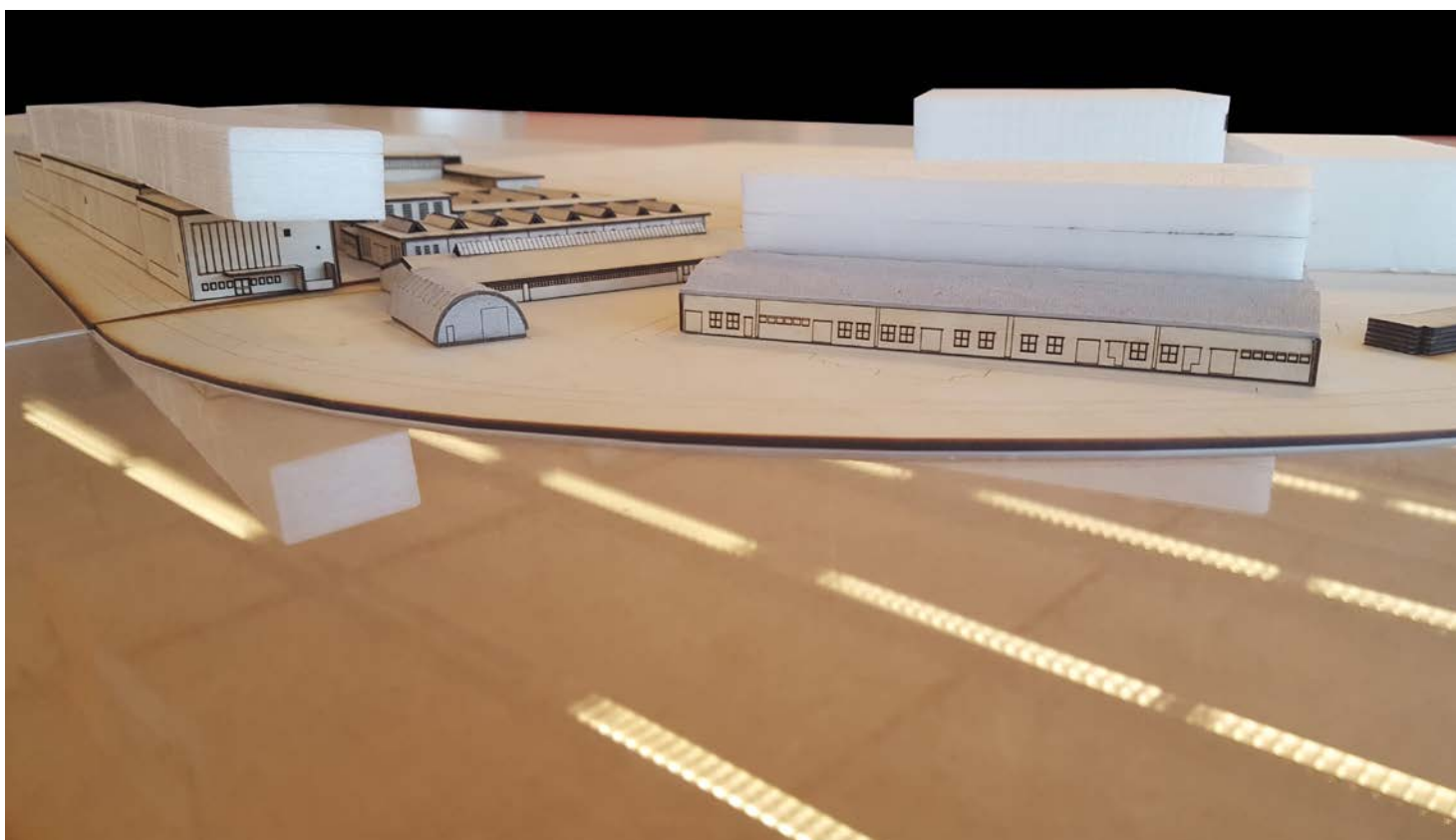
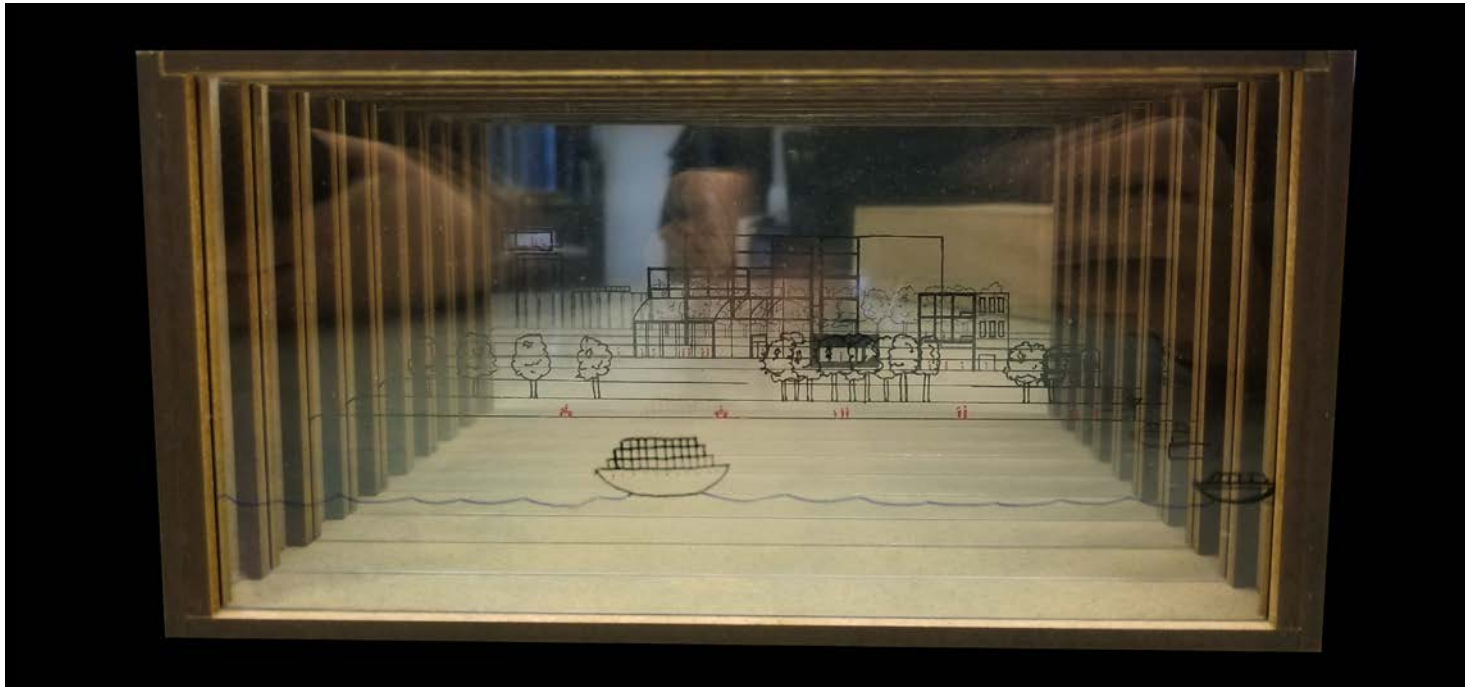

Figure 9. 1:500 model with new masses



## 20X20X20 CREATION

I created an object to express my inspiration about the site. With the only restriction of dimension 20x20x20mm, I made a section box to study the layers of the Head of the Cape. The model is composed of 10 layers of transparent sheets, representing the water, pier, promenade, tree, bunker, existing buildings and new masses. The drawings on the layers can be easily erased and redrawn. By changing the order of these layers, I can test the visual effect of different design schemes quickly.

*Top:  
The 20x20x20 creation*

*Middle:  
Front view of the model*

*Bottom:  
Back view of the model*







# P2

*Capturing the past,  
projecting for the future.*

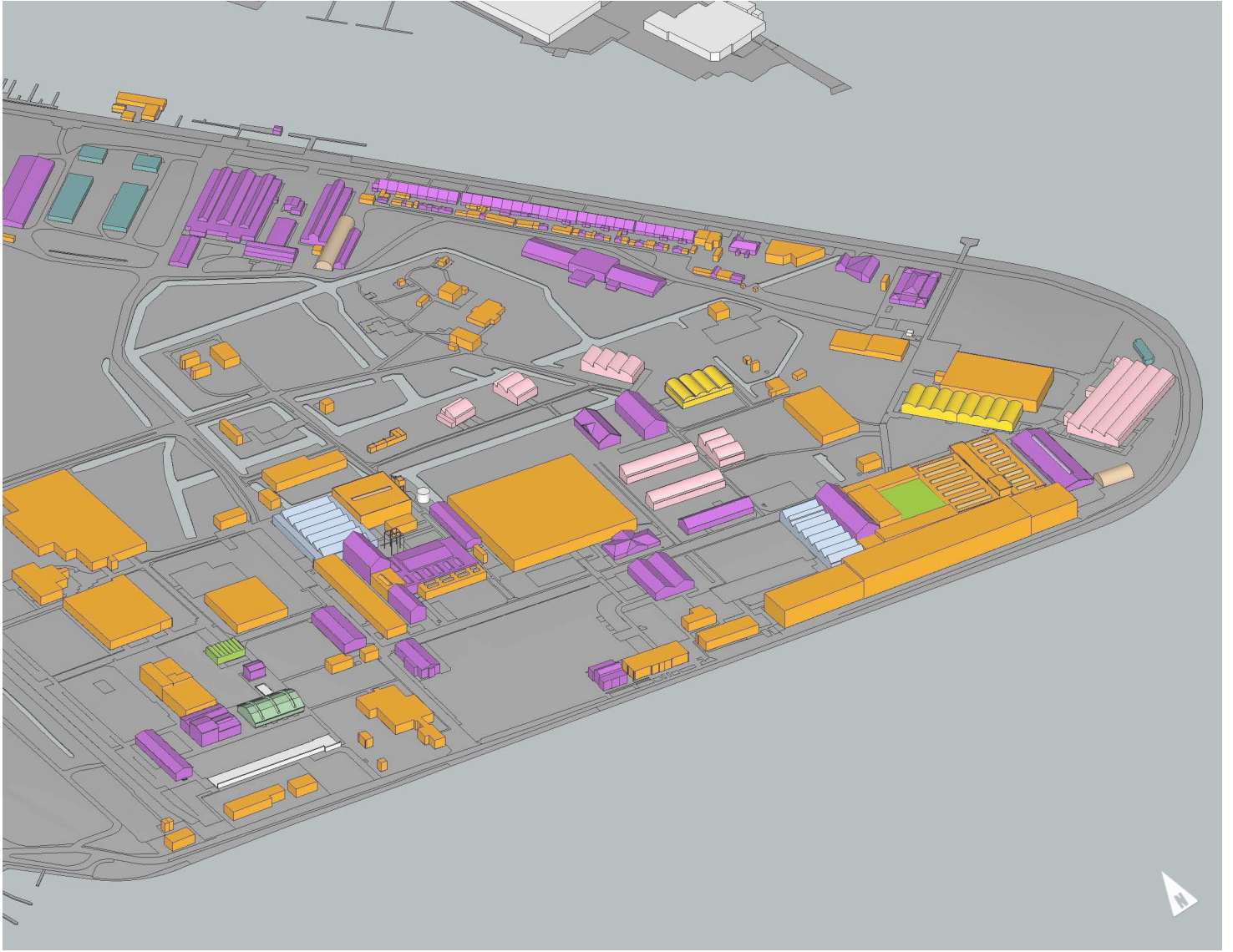

Legend:

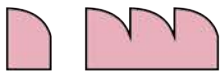

*Curved shell roof*



*Flat roof*



*Pitch roof / Gable roof*



*Barrel vault roof*



*Saw tooth roof*



*Hyperbolic paraboloid roof*



*Gambrel roof*



*Bunker*



*Romneyloads*



## CAPTURING THE PAST

On the reflection of my drawings and sketches before, I discovered that the collective buildings in Hembrug spoke about a particular moment in time. A time where the people of Hembrug had to prepare for the Second World War, while keeping the entire ordeal a secret. This led to the demand for spaces to accommodate for the storage, production and transport of ammunition, as well as the demand for work spaces that had enough lighting, at the same time less distraction from the outside, while catering for any disasters that may occur from the mishandle of gunpowder. In order to create a cultural heritage that can encapsulate this invaluable history of Hembrug, I have studied 5 of these typologies, and extracted qualities from them to capture the historical spirit of Hembrug and inform the design of my building.

*Axonomic map:  
Building shape typologies study*

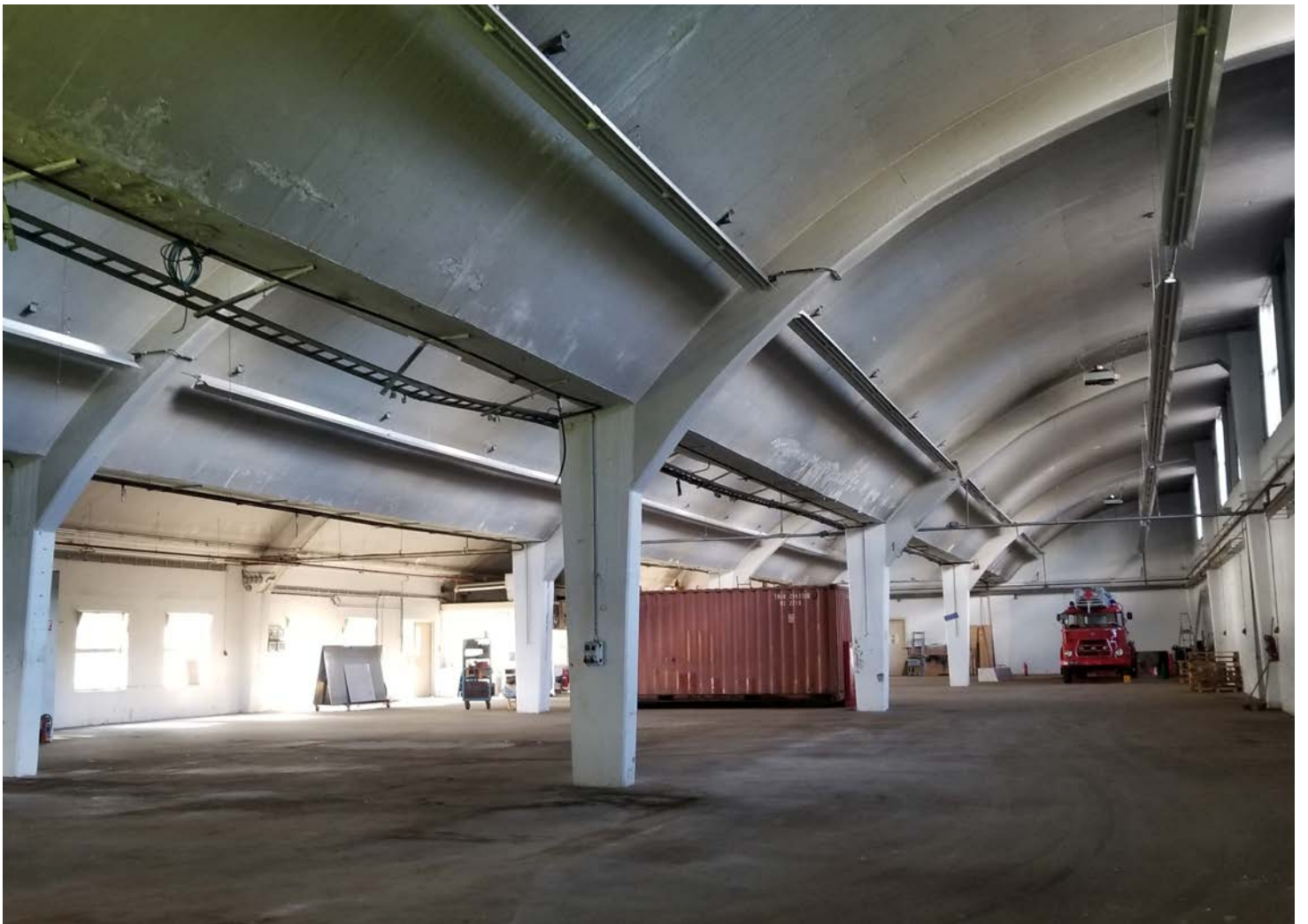

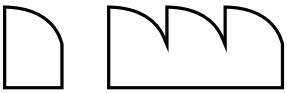

### 1. Curved Shell Roof

The first factory typology that I studied is best represented by the ammunition factory in the Head of the Cape. It has a curved shell roof which is comprised of a series of ridges with a curved surface facing the south and a vertical surface to the north. The vertical surfaces are glazed and they face away from the sun in order to shield workers and machinery from direct sunlight. It reduces heat gain and provides uniform natural light over a large area. This typology can be noticed in several other areas within Hembrug, for instance the Plofbos.

*Top:*  
*Exterior photo of the ammunition factory in the Head of the Cape*

*Bottom:*  
*Interior photo showing the structure, material and spatial quality*



*Structural Elements*

*Materiality*

*Spatial Quality*

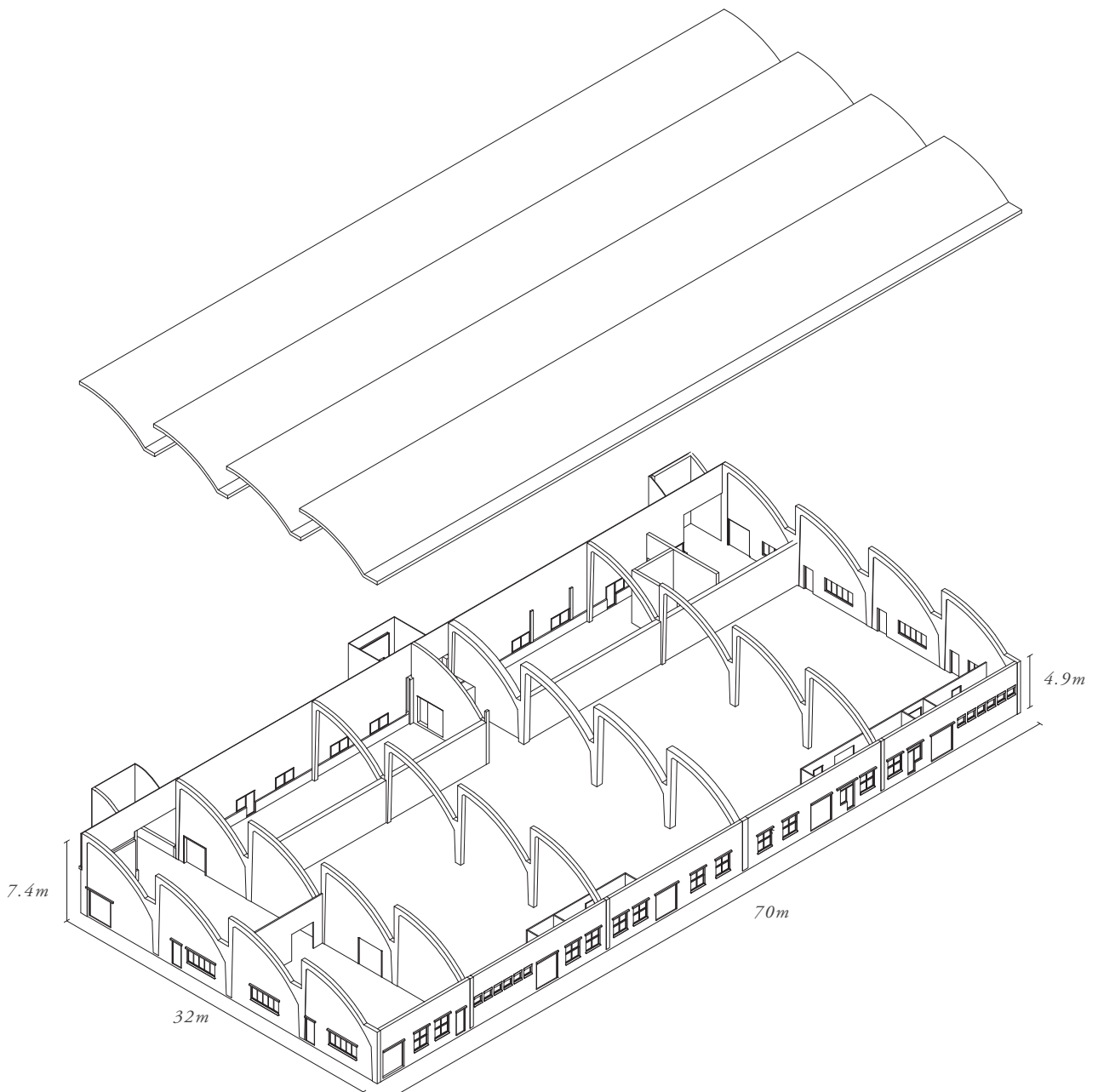
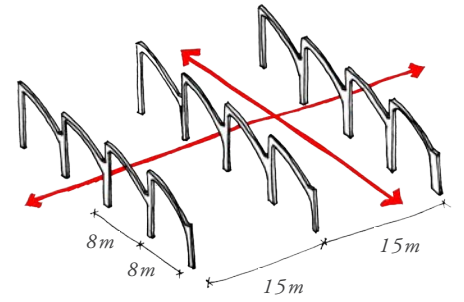
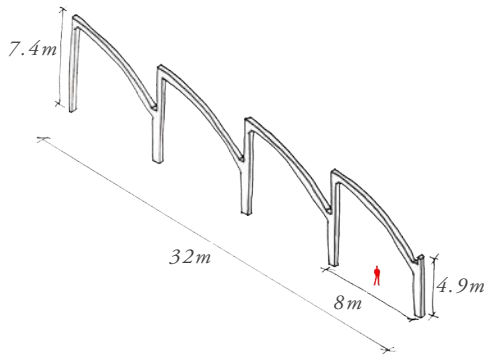



I analyzed each typology in three aspects, structural elements, the materiality and the spatial quality. The extracted components from the five typologies is a general representation of the historical character of Hembrug.

### **Structural element**

The factory is supported by a repetitive structural element, a precast concrete frame made of four consecutive curved profiled portals. The frames are covered by four elongated concrete shell roofs. The line pattern on the ceiling reflects the construction method of the roof in the past. Concrete was poured into a wooden form work to create the inner curved surface. The workers then sprayed concrete onto the reinforced steel mesh to create the outer surface which is then smoothed with a span.

### **Materiality**

Concrete is the primary material used in the ammunition factory, expressed with a structural frame, the curved shell roof and the floor. Brick walls are built as infill of the concrete frames. The two major materials, concrete and brick convey an industrial character of the factory.

### **Spatial quality**

The space of each concrete portal is 8 meters wide. The concrete frames spans 15 meters. The layout suggests a fluid circulation in both longitudinal and latitudinal directions.

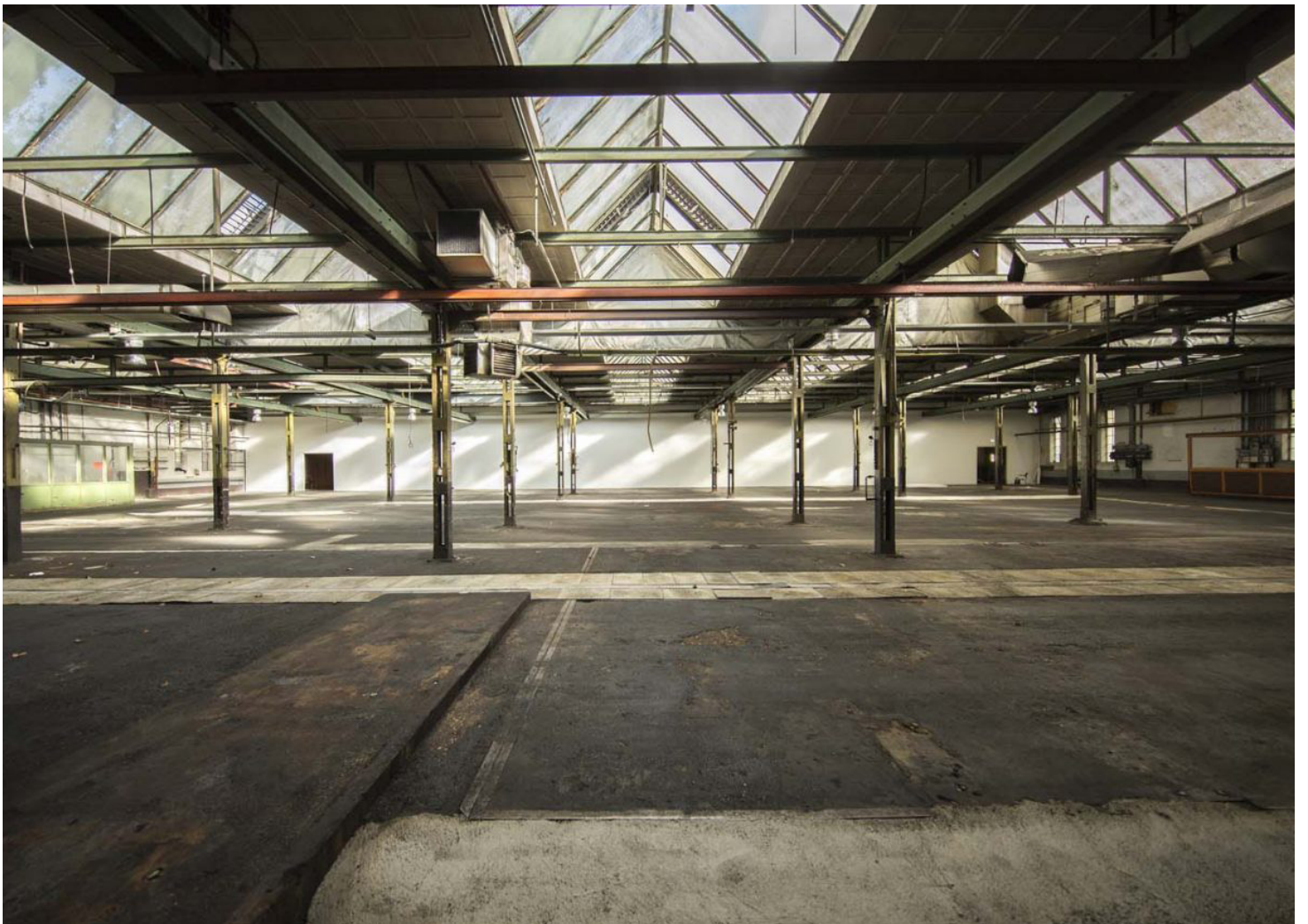



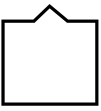

## 2. Flat Roof with Skylights

Built in 1936, the former production hall of grenade bodies was selected as an example to illustrate the typology of the flat roof with skylights.

*Top:*

*Exterior photo of the grenade factory with a flat roof and skylights*

*Bottom:*

*Interior photo showing a series of skylights*

*Structural Elements*

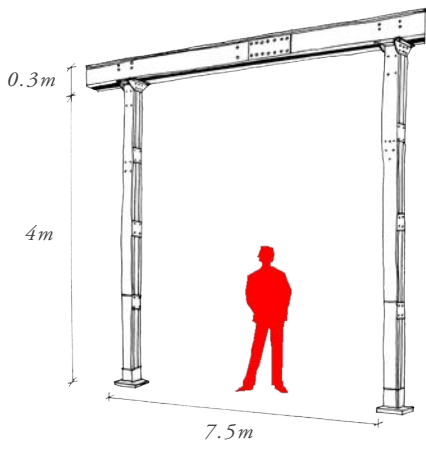

*Materiality*



*Spatial Quality*

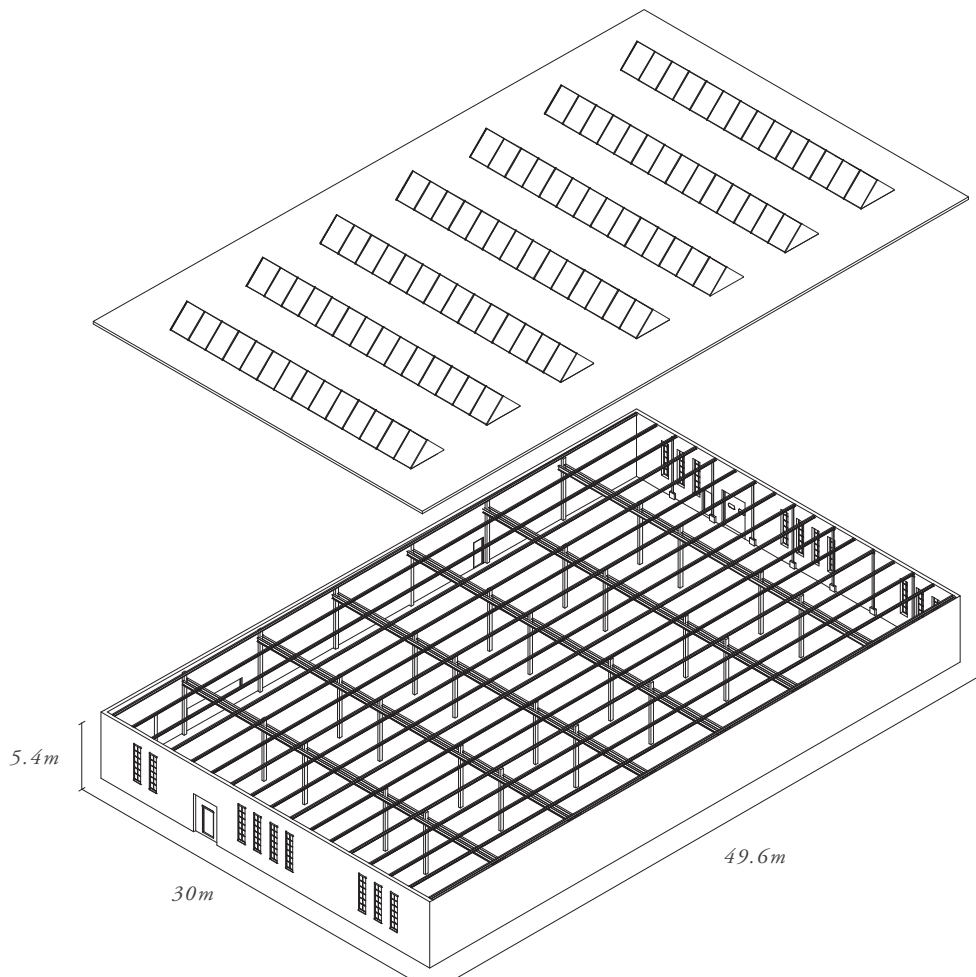
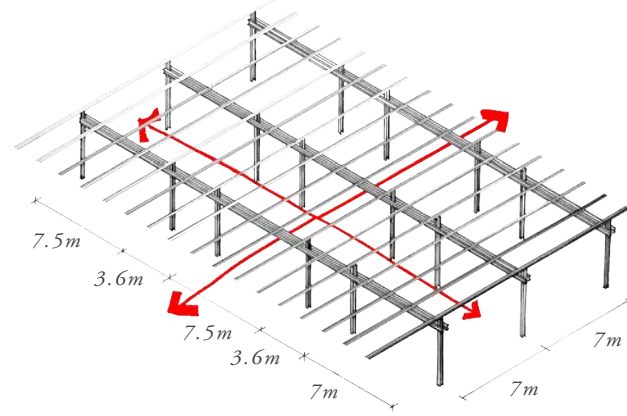

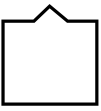

### **Structural element**

The grenade bodies production hall is the lowest building within the connected production halls in the ladder ensemble, 4.3 meters in height. The hall is supported by riveted structural steel columns and beams.

### **Materiality**

The production hall complex is mainly comprised of steel. Despite the same material, the steel elements are painted with different colors to brighten the space, for instance the green slanted steel construction is used to support the skylights, the green steel beams lay on top of the yellowish columns with its bottom part painted as black.

### **Spatial quality**

The layout of the columns sets the rhythm of the space composed by alternate tubular spaces of 7.5 meters and 3.6 meters. The structures are placed 7 meters apart from each other.





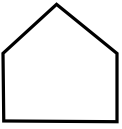

### 3. Pitch Roof or Gable Roof

The factory type with a pitch roof or gable roof is commonly seen in the Hembrug area. Buildings of this typology usually have a high ceiling. The selected example, the production hall is the tallest construction within the Ladder ensemble. The hall is used to house large and high projectile pressing machines<sup>1</sup> which explains the building height of 15 meters that in many ways resembles a Gothic cathedral.

*Top:*

*Exterior photo of the projectile pressing hall in the Ladder*

*Bottom:*

*The interior of the hall resembles a Gothic cathedral*

*Note:*

*I. A. van Unen, A. Moe Soe Let, F. Zafiropoulou, The Ladder Analysis booklet, Heritage and Architecture Graduation studio, 2018-19, p. 24.*

*Structural Elements*

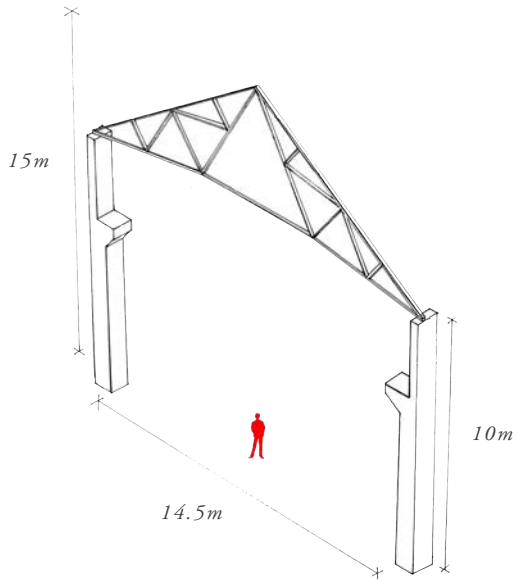

*Materiality*



*Spatial Quality*

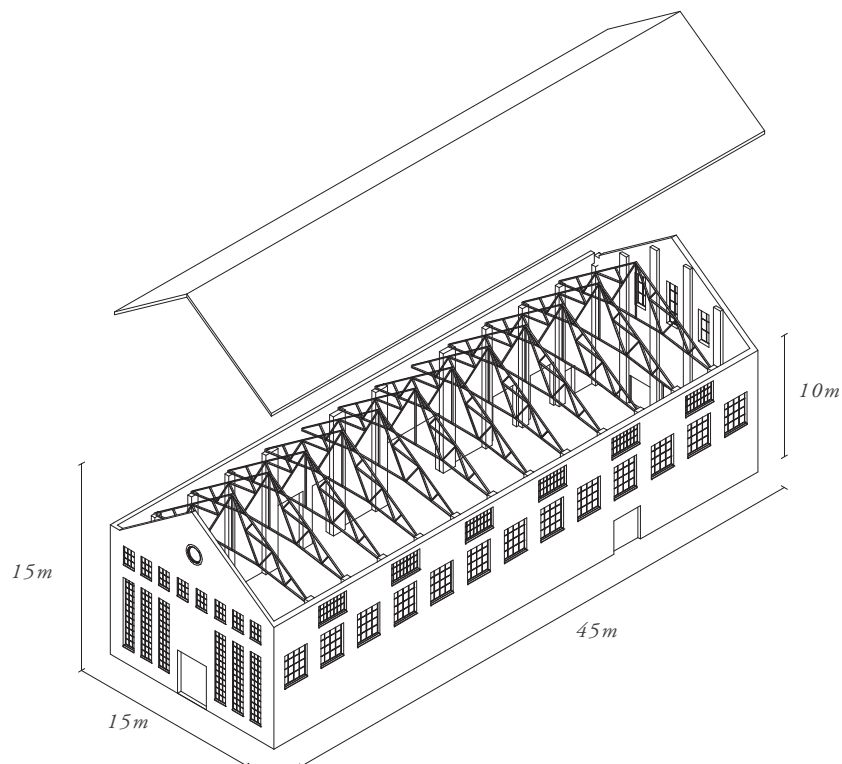
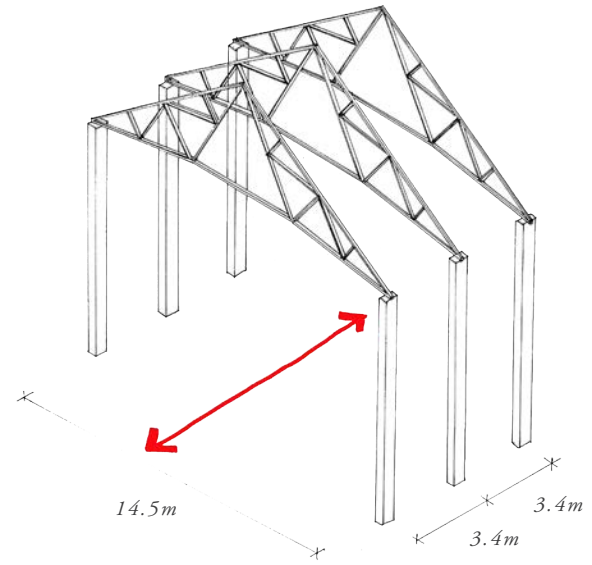



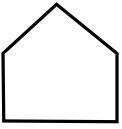

### **Structural element**

The twelve steel polonceau trusses sitting on the concrete columns with corbels together support the bitumen roofing of the production hall.<sup>1</sup>

*Note:*

*I. A. van Unen, A. Moe Soe Let, F. Zafiropoulou, The Ladder Analysis booklet, Heritage and Architecture Graduation studio, 2018-19, p. 55.*

### **Materiality**

Besides the exposed steel fink trusses and the concrete columns, there are also materials like brick wall with plaster on top of it.

### **Spatial quality**

People can notice the verticality of the cathedral like space once they step inside the hall. The 14.5 meters span of the truss creates an expansive space underneath the authentic structure.





#### 4. Barrel Vault Roof

The former cartridge and grenade foundry and warehouse near the Head of the Cape represents the typology of factories with a barrel vault roof. The warehouse is currently used as a wood processing workshop.

*Top:*

*Exterior photo of the former cartridge and grenade foundry and warehouse*

*Bottom:*

*There is an office on the upper level of the warehouse right next to the curved windows.*



*Structural Elements*

*Materiality*

*Spatial Quality*

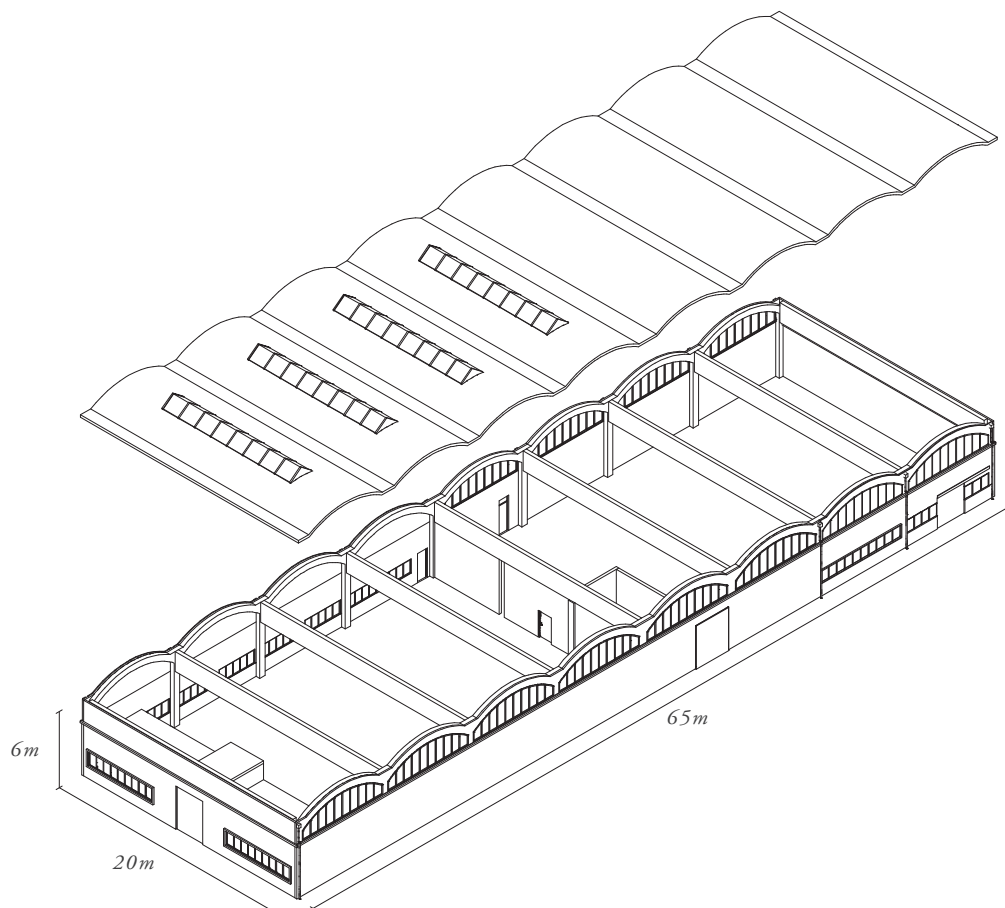
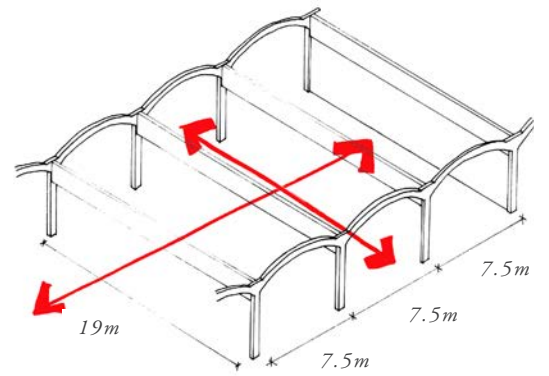
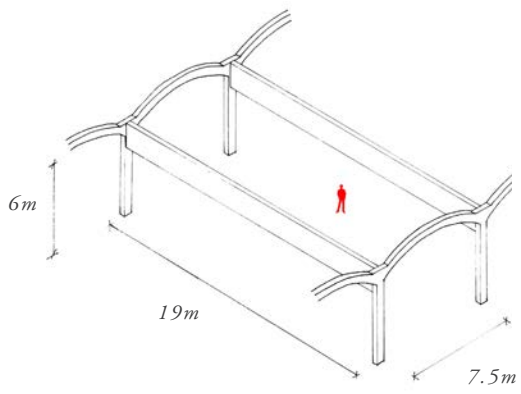



### **Structural element**

The basic structural element is a barrel vault. The building can be read as eight consecutive barrel vaults.

### **Materiality**

The barrel vaults are made out of concrete. The cold and rigid atmosphere is balanced with a warmer material, the wooden partition walls.

### **Spatial quality**

Although the workshop is separated into two spaces with a partition wall in the middle, one can easily imagine an unobstructed rectangular space with the partition wall taken away.





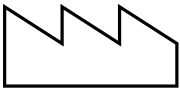

### 5. Saw Tooth Roof

A saw-tooth roof is a roof made from a series of ridges with dual pitches on either side. The steeper surfaces are glazed and they face away from the sun to shield workers and machinery from direct sunlight. This sort of roof is widely adopted in factory buildings during the industrial revolution which allows natural light into the deep plan of a building or factory. This typology can be found in the Changing zone ensemble.

*Top:*

*Exterior photo of the former projectile sawmill*

*Bottom:*

*Interior photo showing the steel structure and prefab Bimsbeton roofing panels*

*Structural Elements*

*Materiality*

*Spatial Quality*

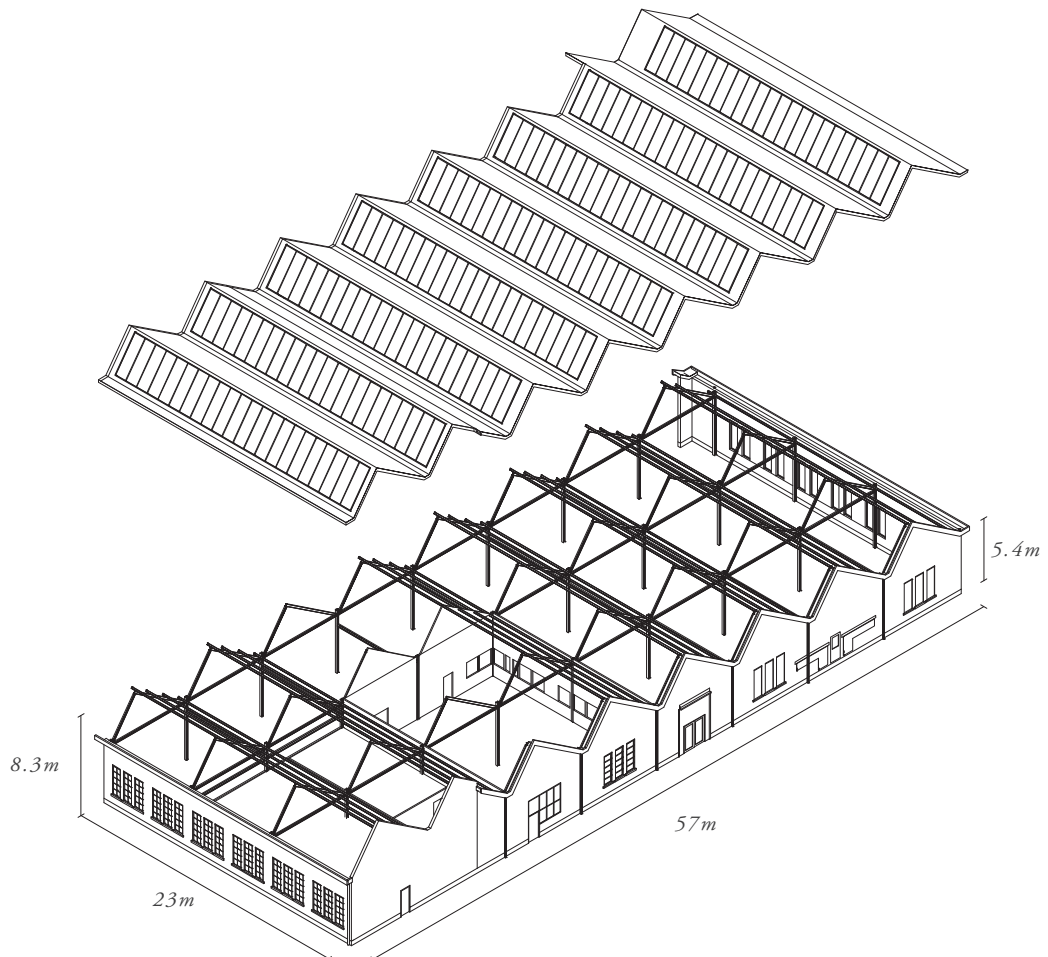
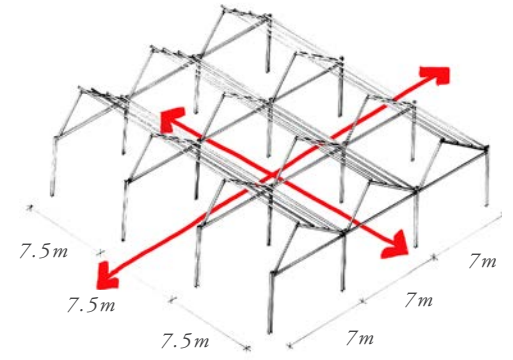
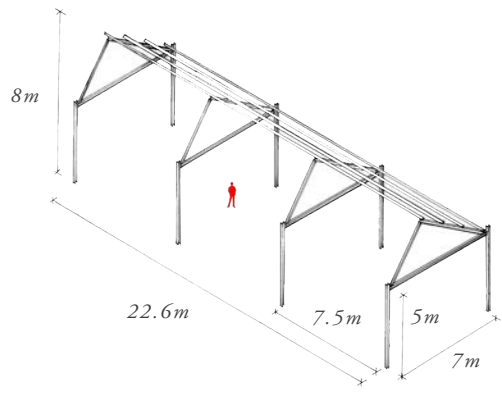

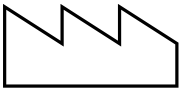

### **Structural element**

The sawmill's structural system is made of steel frame with a HEA profile.<sup>1</sup> The steel beams and columns are welded together with steel plates. Steel beams are welded on one side of the triangular truss to support the prefab Bimsbeton roofing.<sup>2</sup>

### **Materiality**

The combination of steel beams and columns, glass skylights and windows, Bimsbeton roofing and the plaster walls conveys an industrial atmosphere of the place.

### **Spatial quality**

The steel columns are laid in a 7.5 x 7 meters grid. Regardless of the columns, the movement of people is unobstructed.

*Note:*

1. A. van Unen, A. Moe Soe Let, F. Zafiropoulou, *The Ladder Analysis booklet, Heritage and Architecture Graduation studio, 2018-19, p. 54.*

2. A. van Unen, A. Moe Soe Let, F. Zafiropoulou, *The Ladder Analysis booklet, Heritage and Architecture Graduation studio, 2018-19, p. 116.*



# TYPOLOGICAL STUDY: THE DESIGN TOOLBOX

*Typology*

*Building Examples*

*Structural Element(s)*

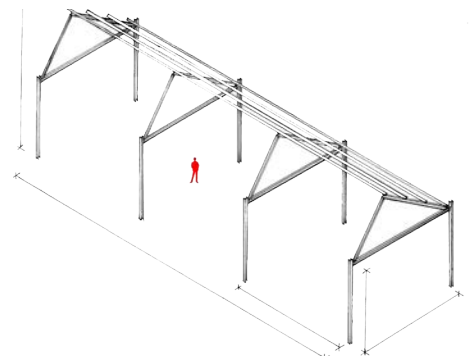
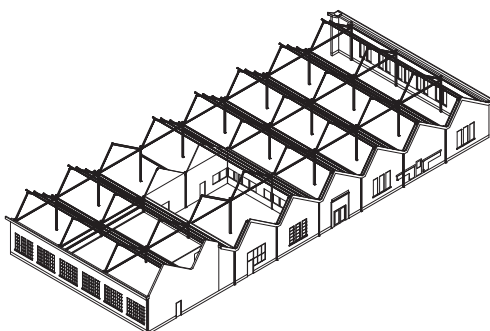
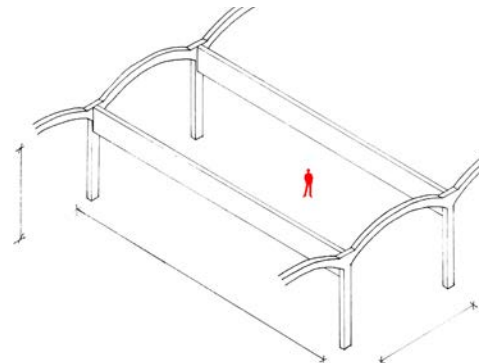
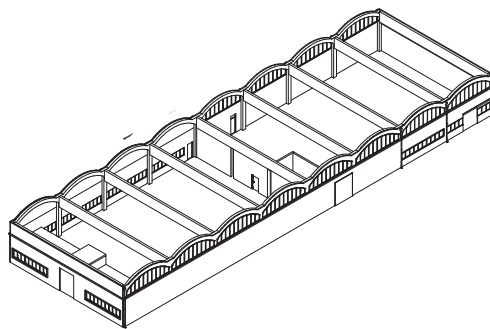
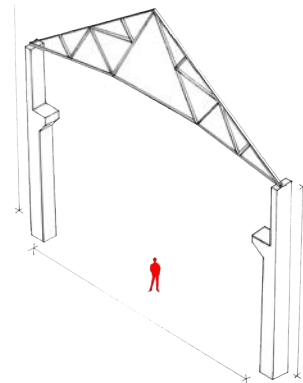
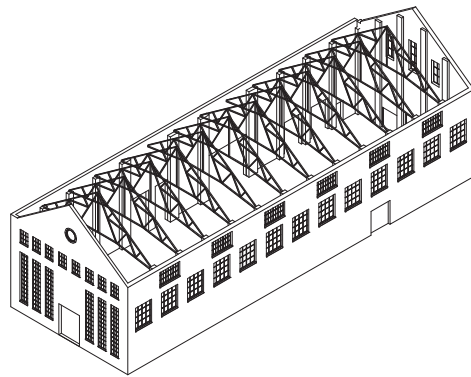
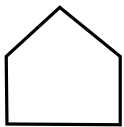
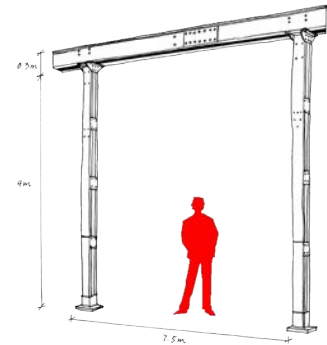
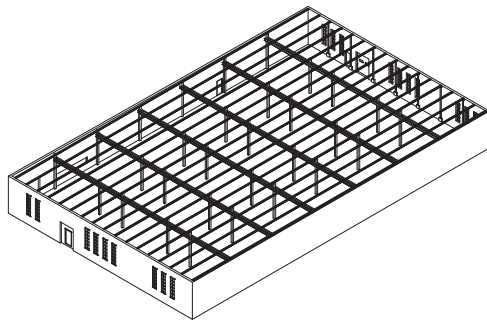
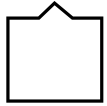
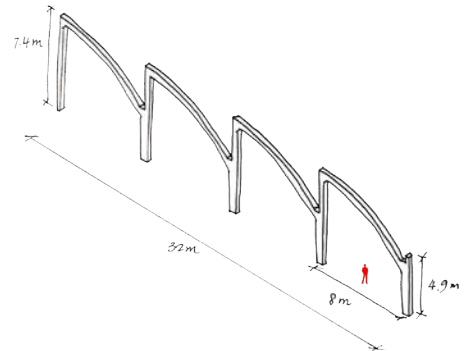
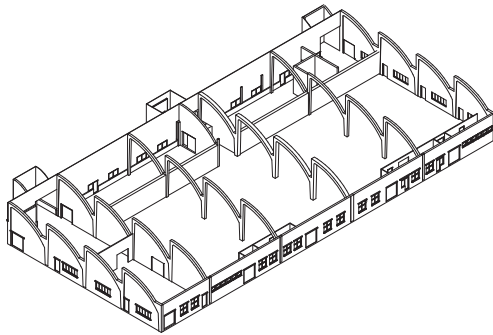

Materiality

Spatial Quality

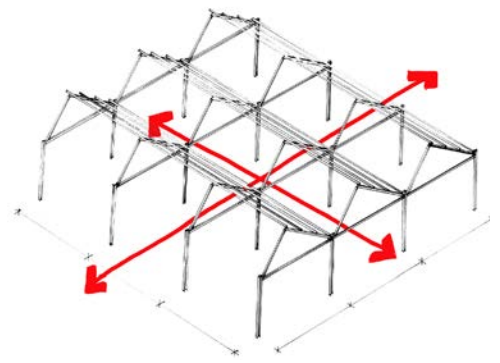
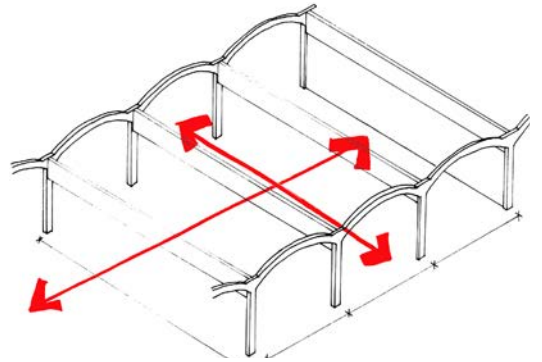
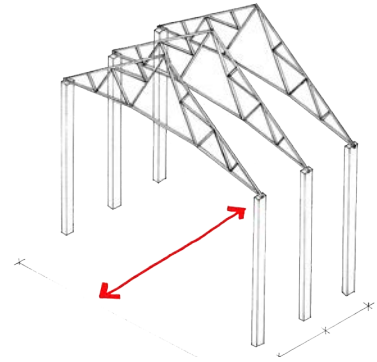
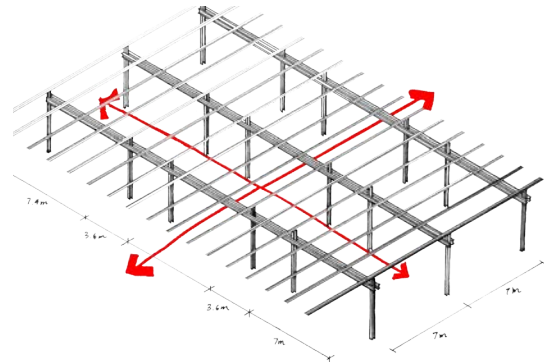
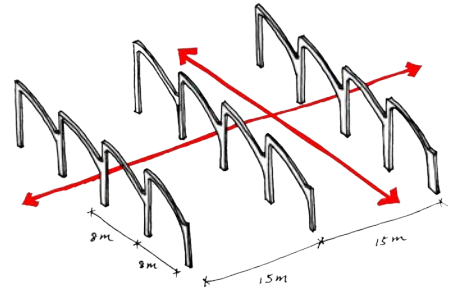

# CAPITALIZING THE POTENTIAL

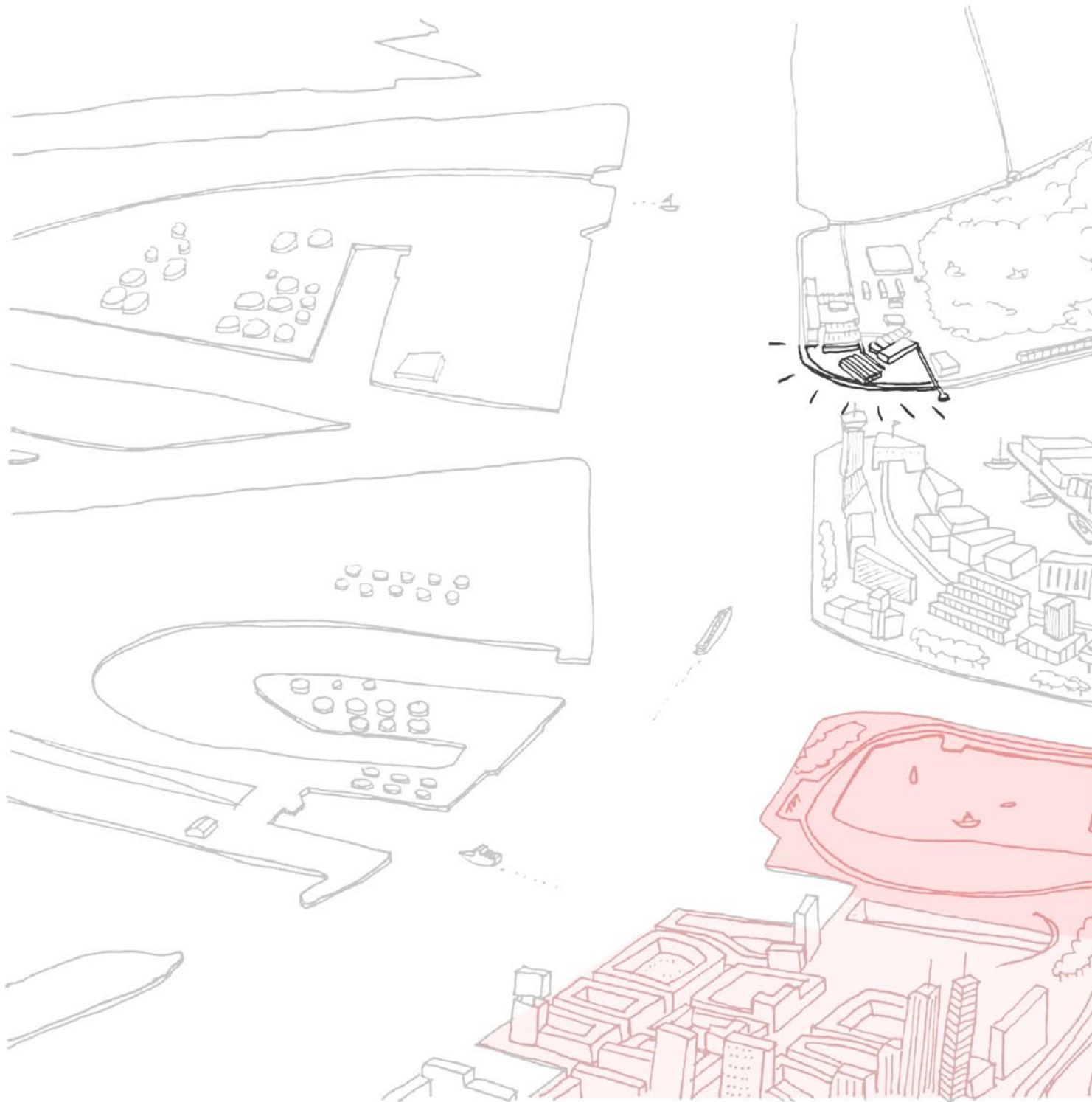

Legend:

■ Noorder IJ-plas

■ Haven-Stad planning area





In order to respond to the foreseen growth of inhabitants in Amsterdam, the Municipality of Amsterdam have drafted a document “Structuurvisie Amsterdam 2040” in 2011, which depicts the 2040 scenario of the city - a metropolis with sufficient affordable housing in various locations and space for green. The document proposed for the construction of 70,000 additional homes.<sup>1</sup> In the document “*Haven-Stad - Transformatie van 12 deelgebieden*”, the municipality envisioned a new district, Haven-Stad, made of 12 contiguous locations within the Rijksweg 10 (the motorway of Ring A10), where housings, shops, businesses and facilities are combined. The mixed urban area will provide at most 70,000 homes and 58,000 job positions.<sup>2</sup> It is expected that more than 150,000 people would be living and working in Haven-Stad. An important precondition for this high dense urban area is that there has to be sufficient space available for social amenities such as schools, sports and recreational facilities. With a distance of 1.5 km away from the future Haven-Stad, the Head of the Cape can be reached from Noorder IJ-plas 15 minutes by bike or 10 minutes by car, making it the ideal location to provide cultural and recreational space for the projected growth in population.

*Note:*

1. *Economically strong and sustainable Structural Vision: Amsterdam 2040*, Gemeente Amsterdam, 2011

2. *Haven-Stad Transformatie van 12 deelgebieden*, Concept Ontwikkelstrategie, Gemeente Amsterdam, 2017, p. 11, 13.

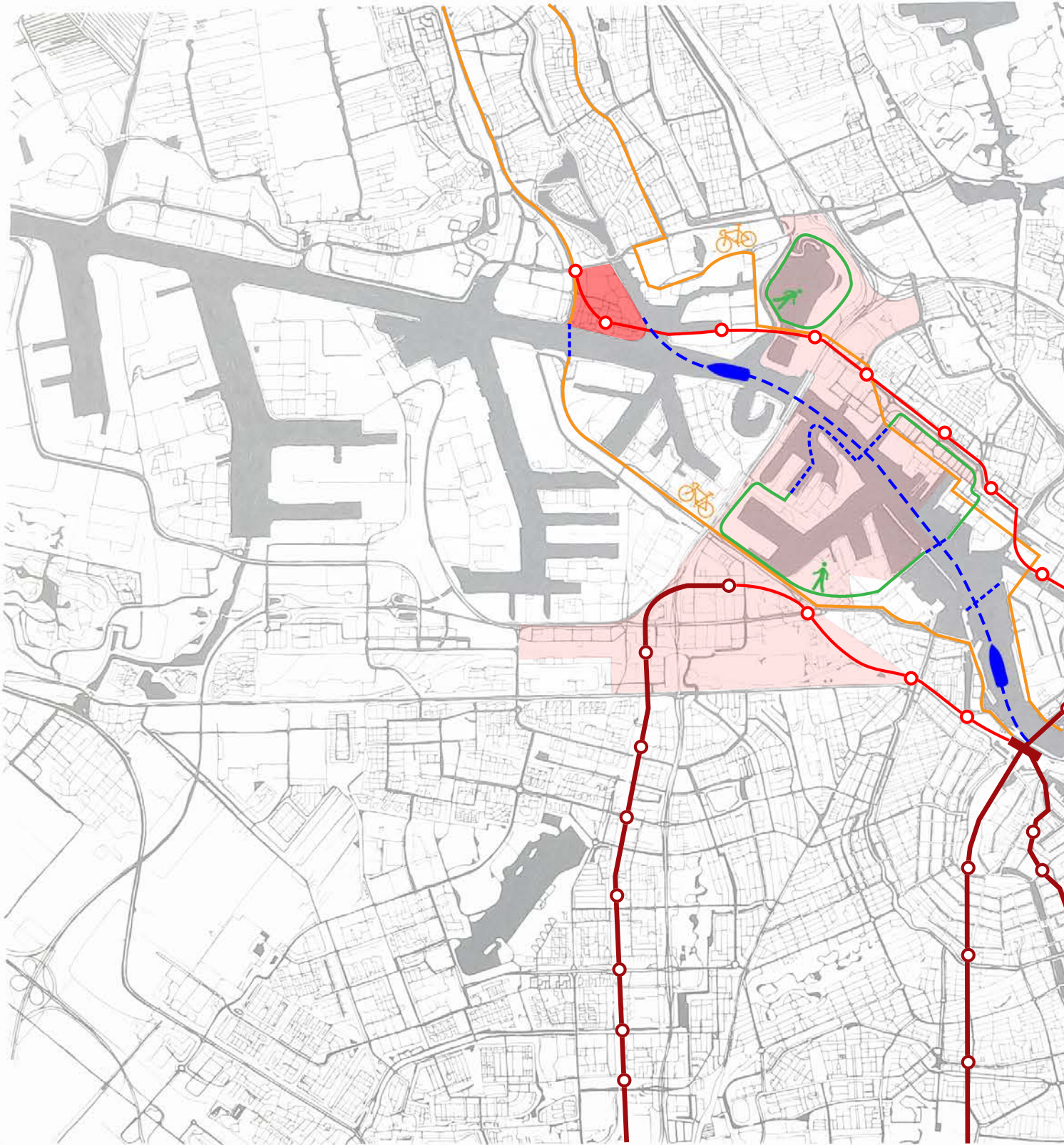

Legend:

Hembrug

Haven-Stad  
planning area

Existing metro line

Proposed metro line







One of the emphasis of the future Haven-Stad is to enhance the network for public transport, cyclists and pedestrians. The document focuses on a high-quality public transport infrastructure (bus, tram and metro), giving priority to cyclists and pedestrians in the area.

The car thus plays a significantly smaller role. In doing so, we have to take into account the fact that the businesses requires sufficient adequate car accessibility. Investments in the car network are therefore necessary, but it is critical to limit them so that it is not dominant in the urban framework. Incidentally, a financially viable high-value public transport is only possible if there are sufficient densities in the area. Conversely, high-quality public transport interchanges can in turn act as development vehicles for real estate in the area.

With a better transportation system, Hembrug is more accessible from Amsterdam, Zaandam and even from Schipol airport. The Head of the Cape can serve as a convenient and representative venue for world class events, conferences and festivals.

*Note:*

1. *Haven-Stad Transformatie van 12 deelgebieden, Concept Ontwikkelstrategie, Gemeente Amsterdam, 2017, p. 42.*



THEME : # HISTORICAL PATH / JOURNEY

EXISTING BUILDING	FORMER FUNCTION	NEW FUNCTION	EXISTING m <sup>2</sup>	NEW m <sup>2</sup>	PERCENTAGE INCREASE(%)
382	BUNKER	MONUMENT / MUSEUM	107	107	0%
421	WAREHOUSE	MARKET	1129	1129	0%
430	FACTORY	RESIDENTIAL & MALL & TEAHOUSE	2369	4659	96.6%
512	STORAGE	DEMOLISHED	220	-	-100%
511	STORAGE & PARKING	RESIDENTIAL HOTEL VILLAS	1913	10200	433%
			-	5713	
			-	827	

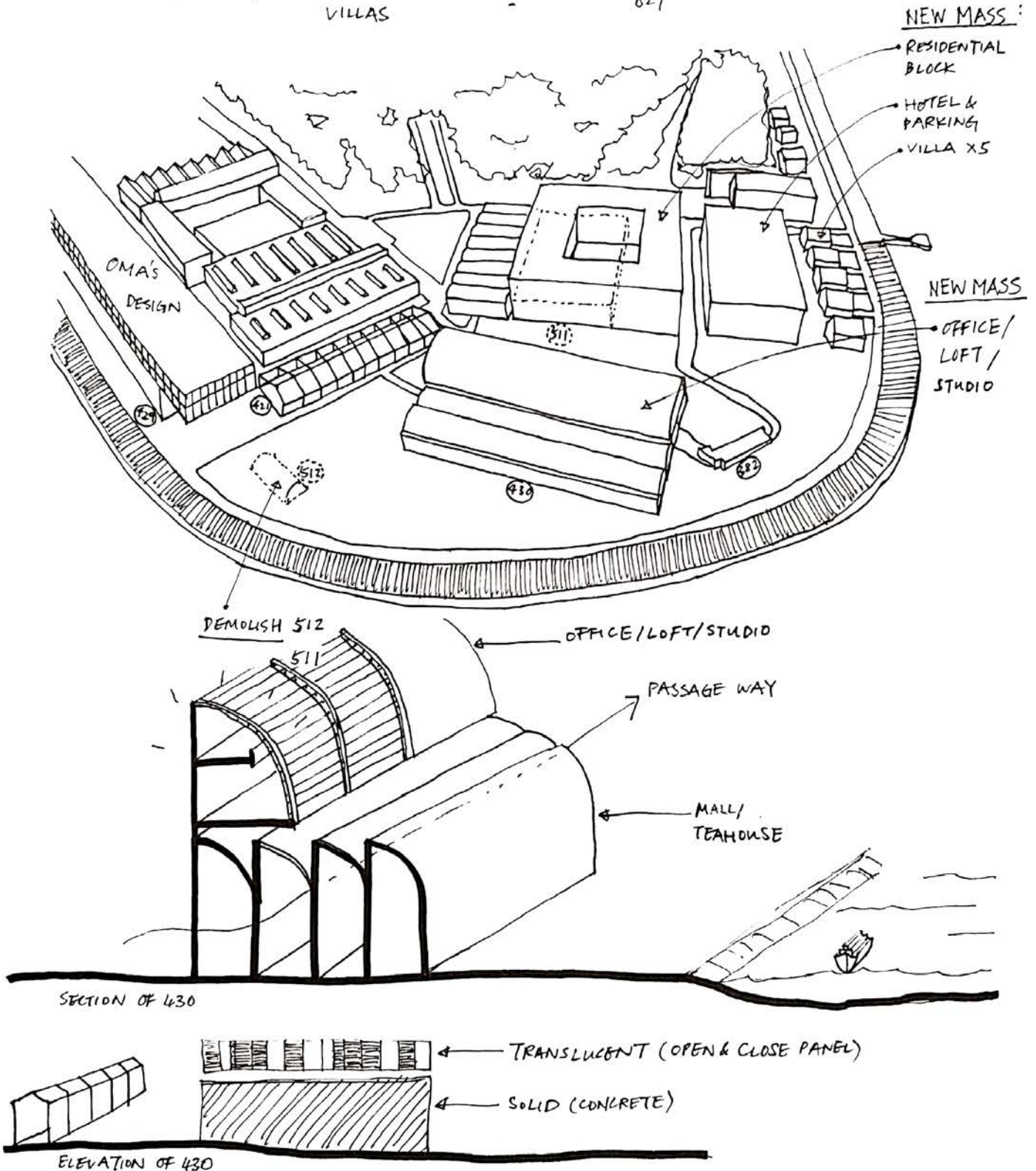

# A CALL FOR CULTURAL LANDMARK

Having conducted the typological study and explored the present opportunities of the site location, I have come to realize that it calls for a very specific program, a program that will be useful for present and future residents – without diminishing the quality of the historical buildings.

*Sketch:  
Preliminary proposal for programs and  
new masses in the Head of the Cape*

In my design, I intend to capture the historical essence of Hembrug and to capitalize on the potential of the location to create a cultural hub to hold communal activities, events and festivals that will steer the future development of Hembrug. The cultural hub will include a black box theater, a restaurant, a ticket office and some residential units, all connected by a passage built with a symbolic structure based on the typological study.

The selection of my programs is also supported by the site analysis of the Head of the Cape. There are three reasons that calls for a cultural hub:

1. Visibility of Hembrug
2. The uniqueness of site location in relation to the grid system of Hembrug
3. Projected development of Hembrug



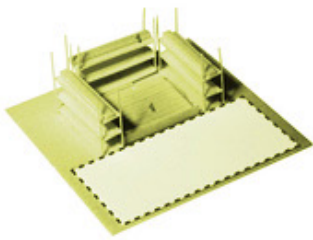

Proscenium

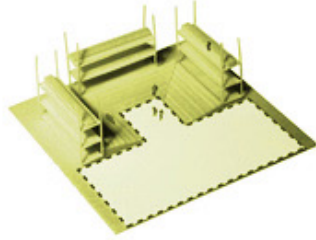

Thrust

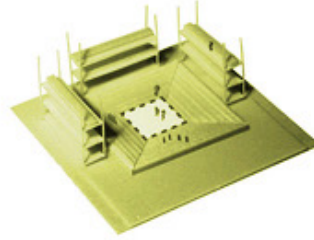

Arena

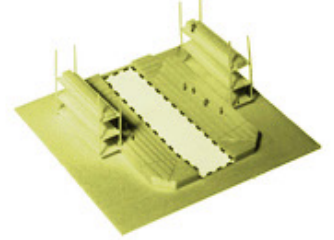

Traverse

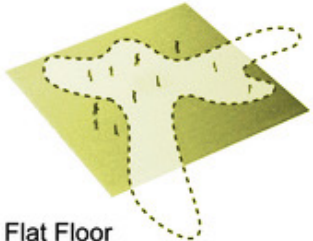

Flat Floor

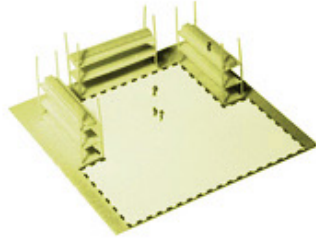

Studio Theater

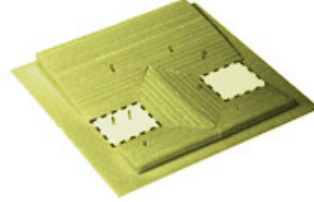

Bipolar

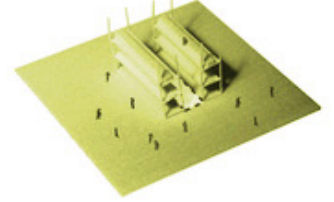

Sandwich

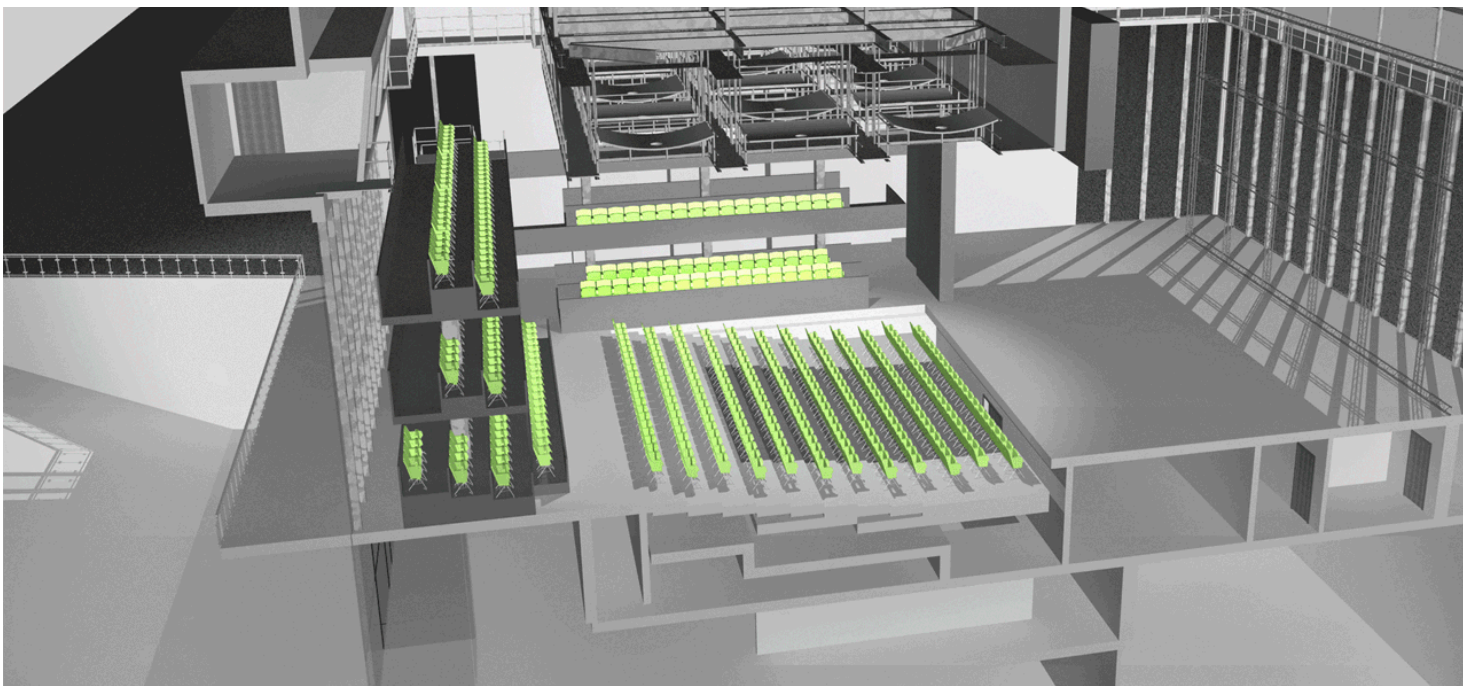
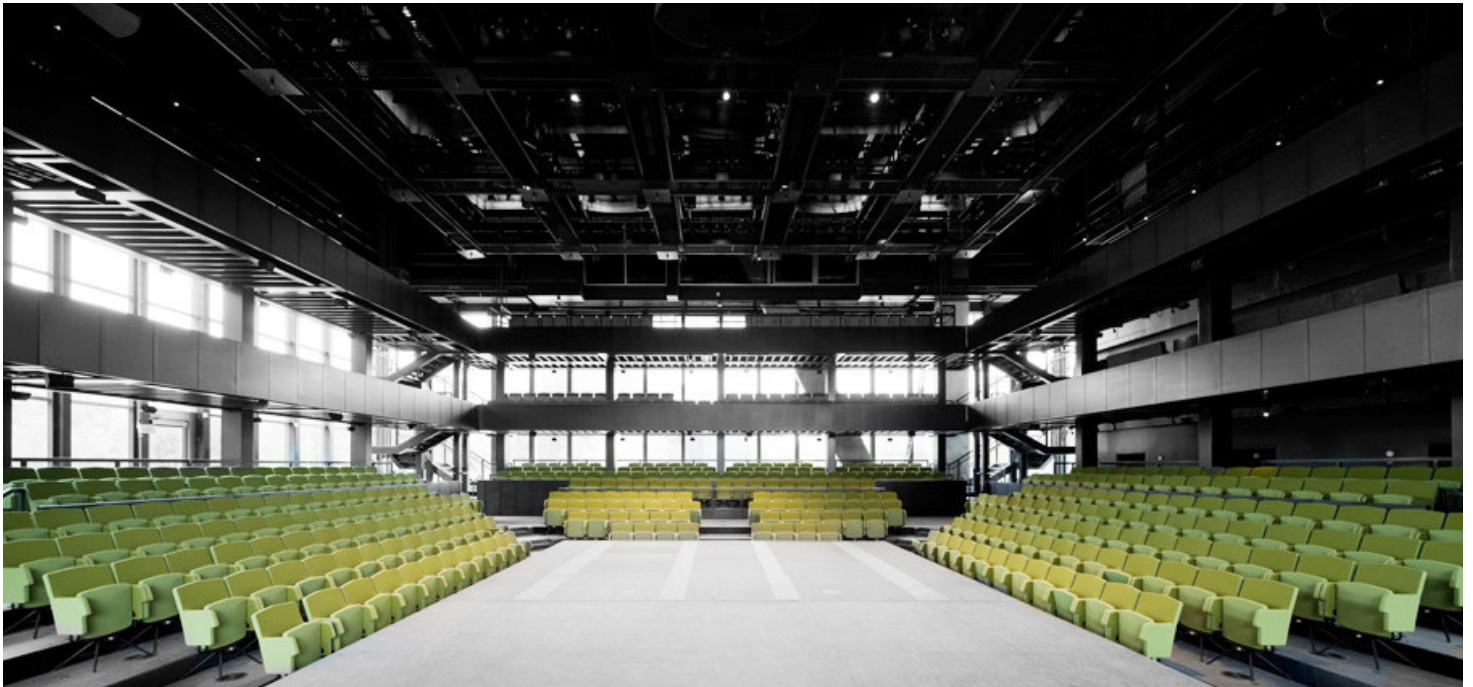



# BLACK BOX THEATER STUDY

Since I proposed there is a black box theater in the cultural hub, I did a little research on what exactly it is through looking at the case study of Wyly Theater by REX and OMA.

As suggested by its name, a black box theater is simply a box like performance venue with an open plan layout. It is a multipurpose "void". Seatings, lightings, stage(s) and platforms in a black box theater are all flexible. It can be adapted to almost any configuration to cater different theatrical programs. There are some configuration settings shown on the left. The example is taken from Wyly Theater by REX and OMA. The main performance space can be set up in many configurations in only a few hours with an unique setting for each show, giving directors and designers unlimited opportunities.

*Top:*  
*Different configuration settings in Wyly Theater*

*Middle:*  
*Ground floor performance space in thrust configuration*

*Bottom:*  
*Sectional perspective of the ground floor performance space in proscenium configuration*

*Source:*  
*1. <https://rex-ny.com/project/wyly-theatre/>*  
*2. <https://www.archdaily.com/37736/dee-and-charles-wyly-theatre-rex-oma>*

# SPATIAL QUALITY OF THE CAPE

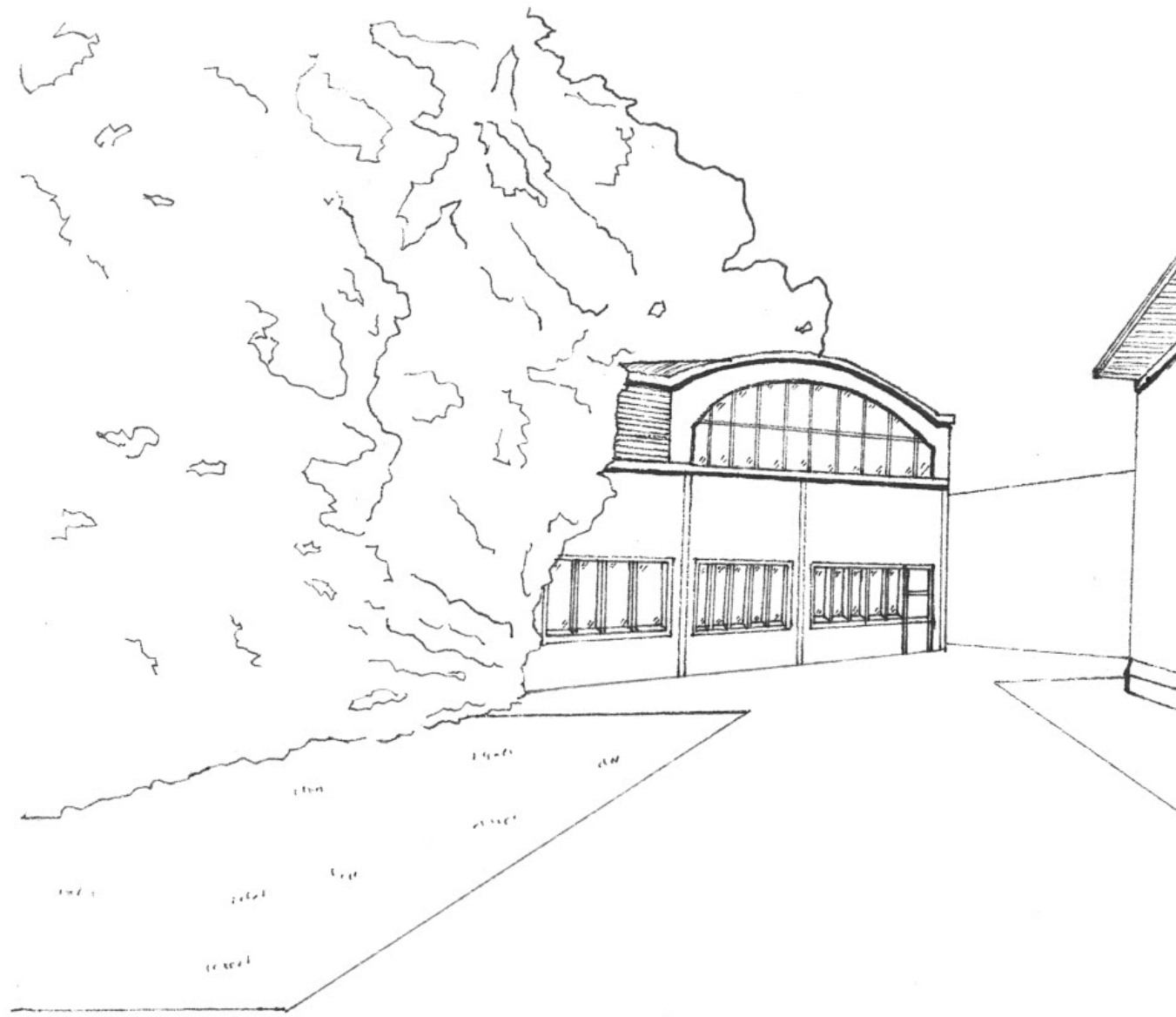



The Head of the Cape is a hidden gem that can be only found through navigating a pathway defined by a set of historic buildings along Middenweg, one of the main roads of Hembrug. The historical buildings are arranged in a way so that walking down the path is a mysterious journey, characterized by different degrees of open and closed spaces, which at the end opens up completely to an unobstructed view of the harbor. I intend to capitalize on this journey to create a historical walk through experience, with the final destination being a theater that embodies the typologies of Hembrug's architecture.





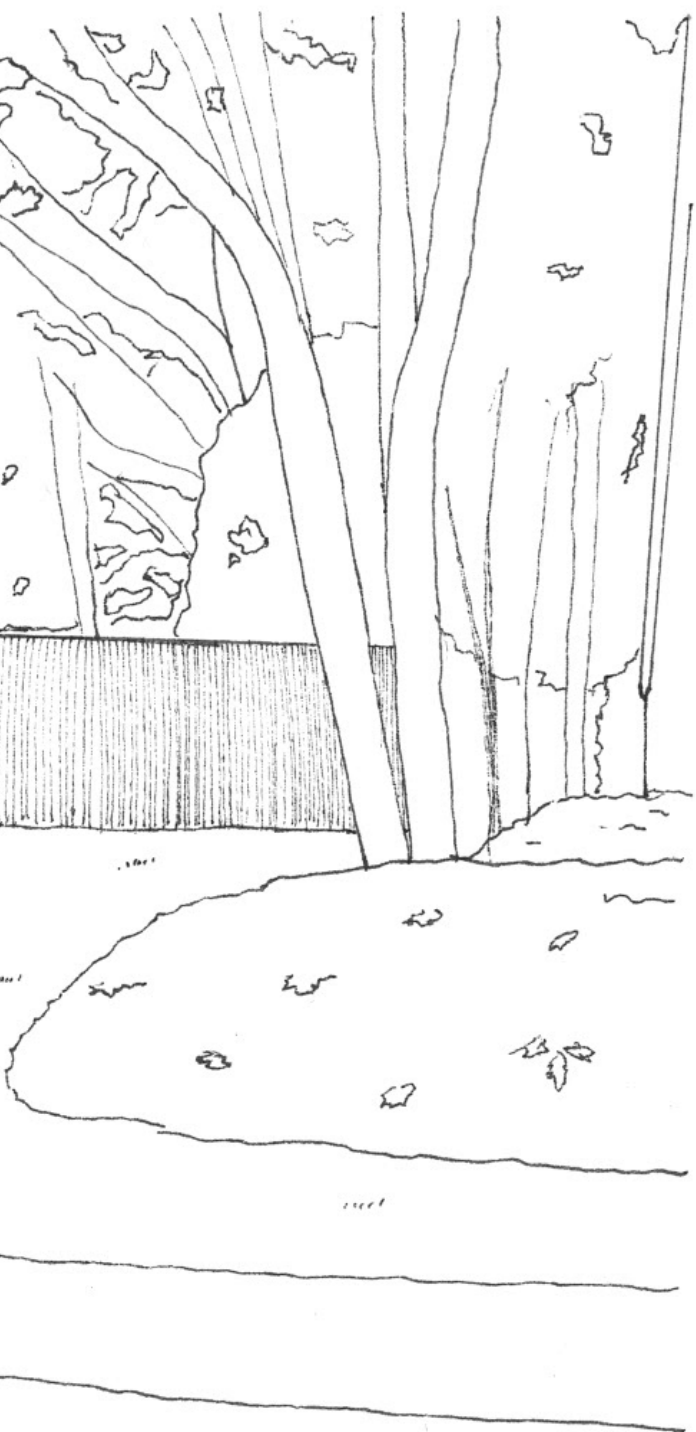

As you turn around the corner, the space suddenly opens up to the Noordzeekanaal, framed by the building facades of the ammunition factory and the projectile workshop. At the moment the Romneyloods obstructs the vision to the canal, which when removed can create a peek into the waterfront.

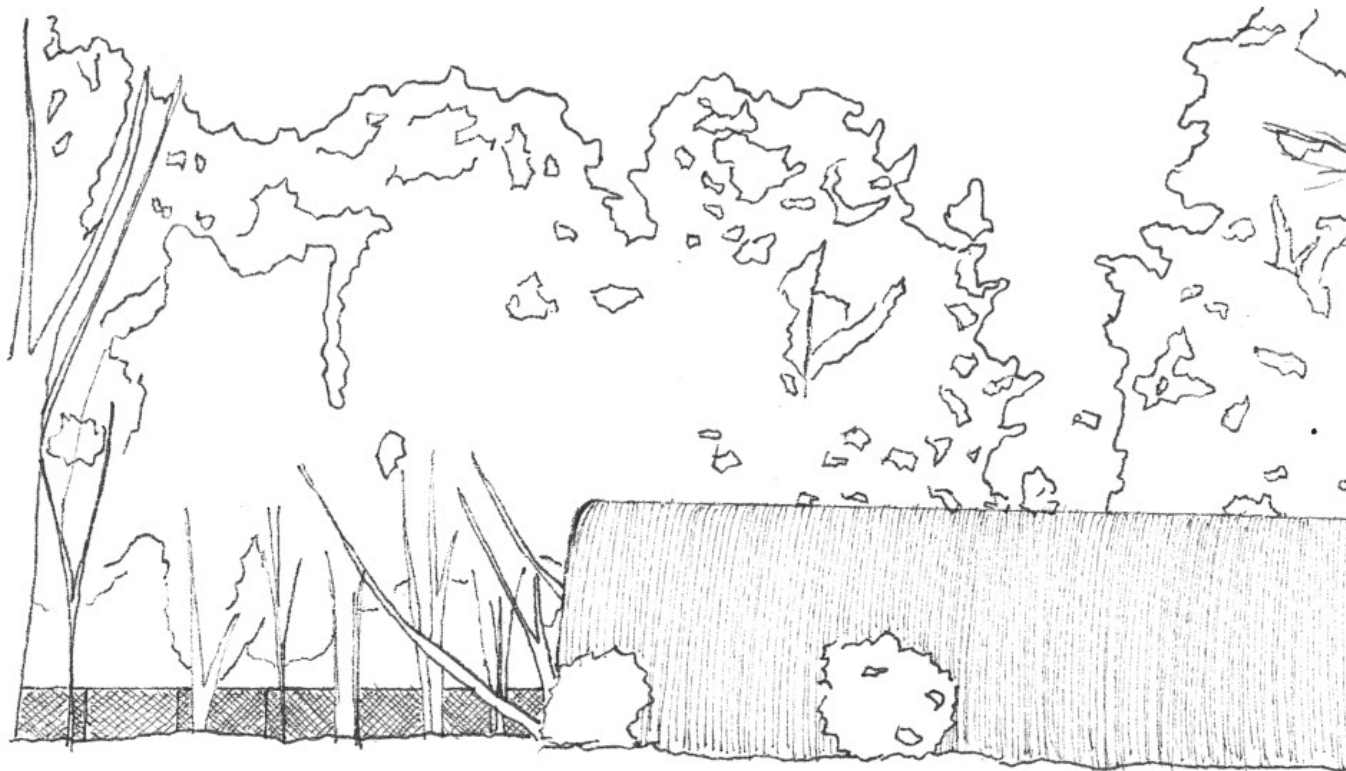



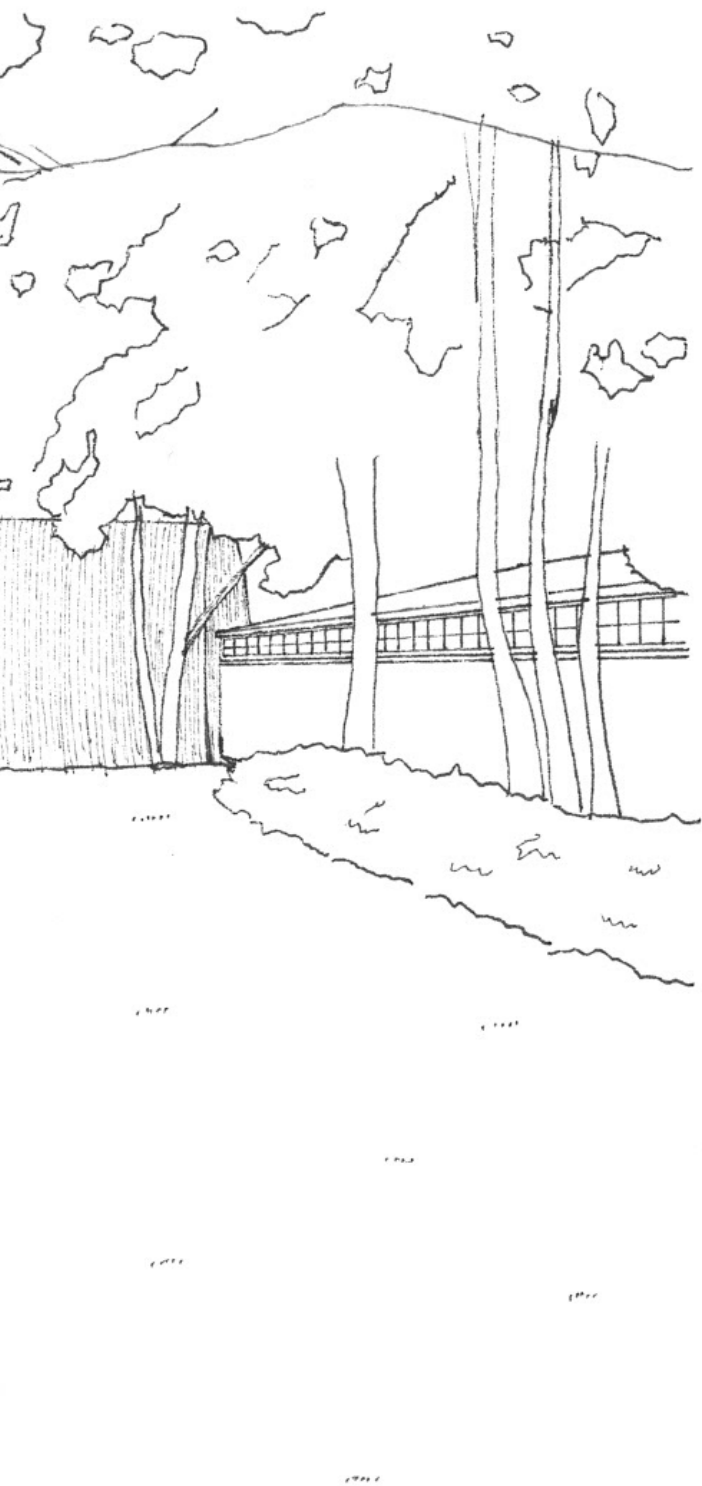

The space framed by the two facades coincidentally creates a very pleasant human scale plaza which is perfect for a small gathering place for an event.

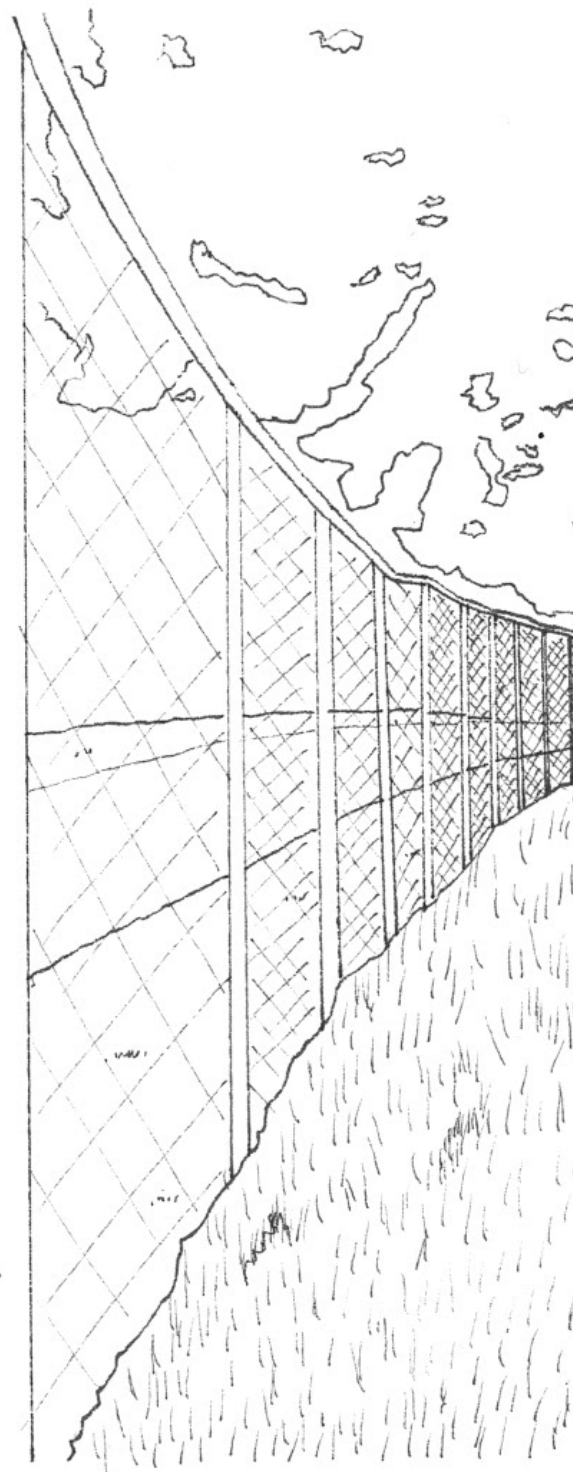
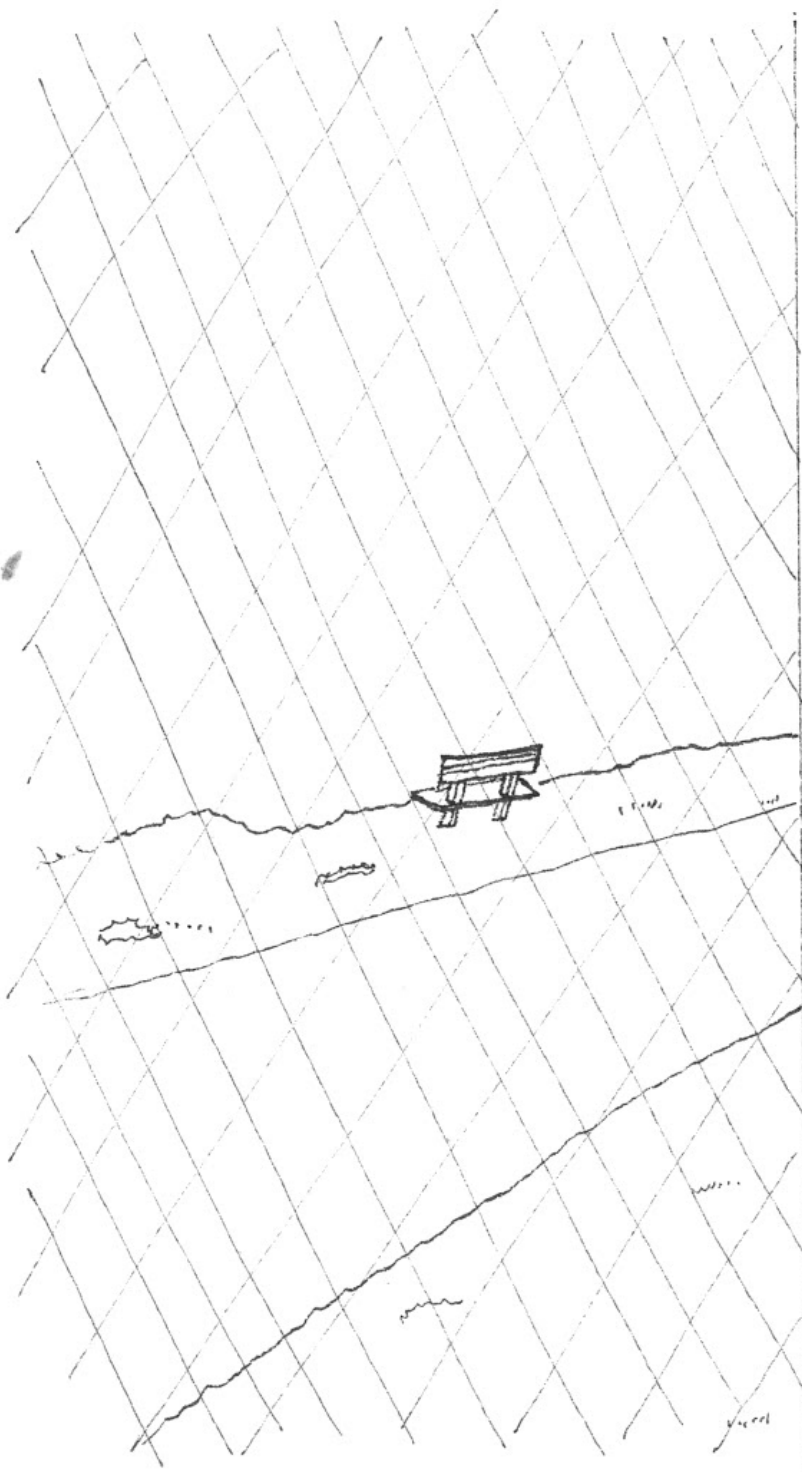



The fence demarcates the boundary between the lawn and the road. When removed or permeated with entrances, it has the potential to connect with the promenade.



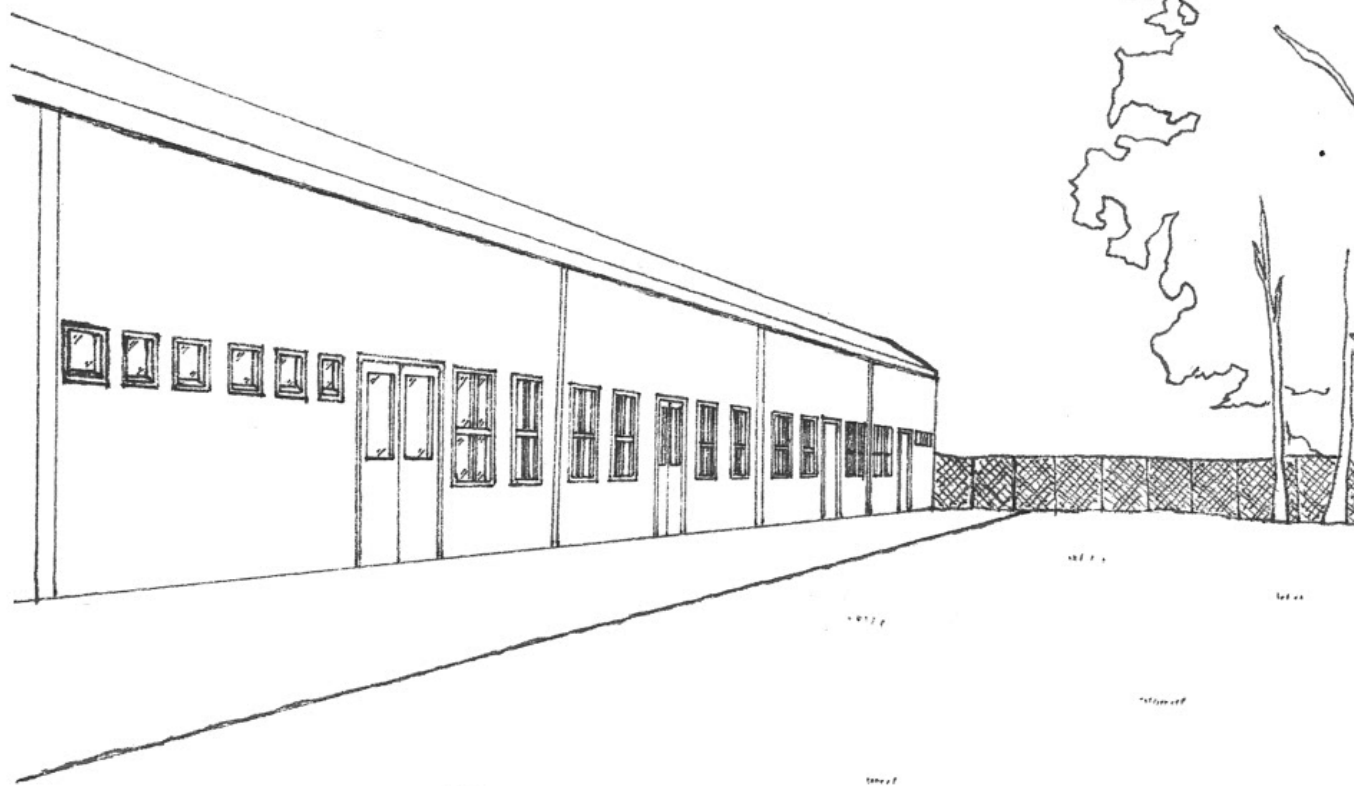

1000000

1000000

1000000

1000000

1000000

1000000

1000000

1000000

1000000

When you turn and reach the green lawn in front of the factory, you reach to the tip of Hembrug, as if its the final destination of the whole journey. The stunning view makes the whole journey rewarding, with a direct visual connection to the North Sea canal and the Polder.







When you walk down the lawn, there is a surprising turn, 2.1m wide defined by the ammunition factory and the fence. It opens up to a 4.6m wide corridor. As you walk down, the bunker beyond the fence becomes visible.

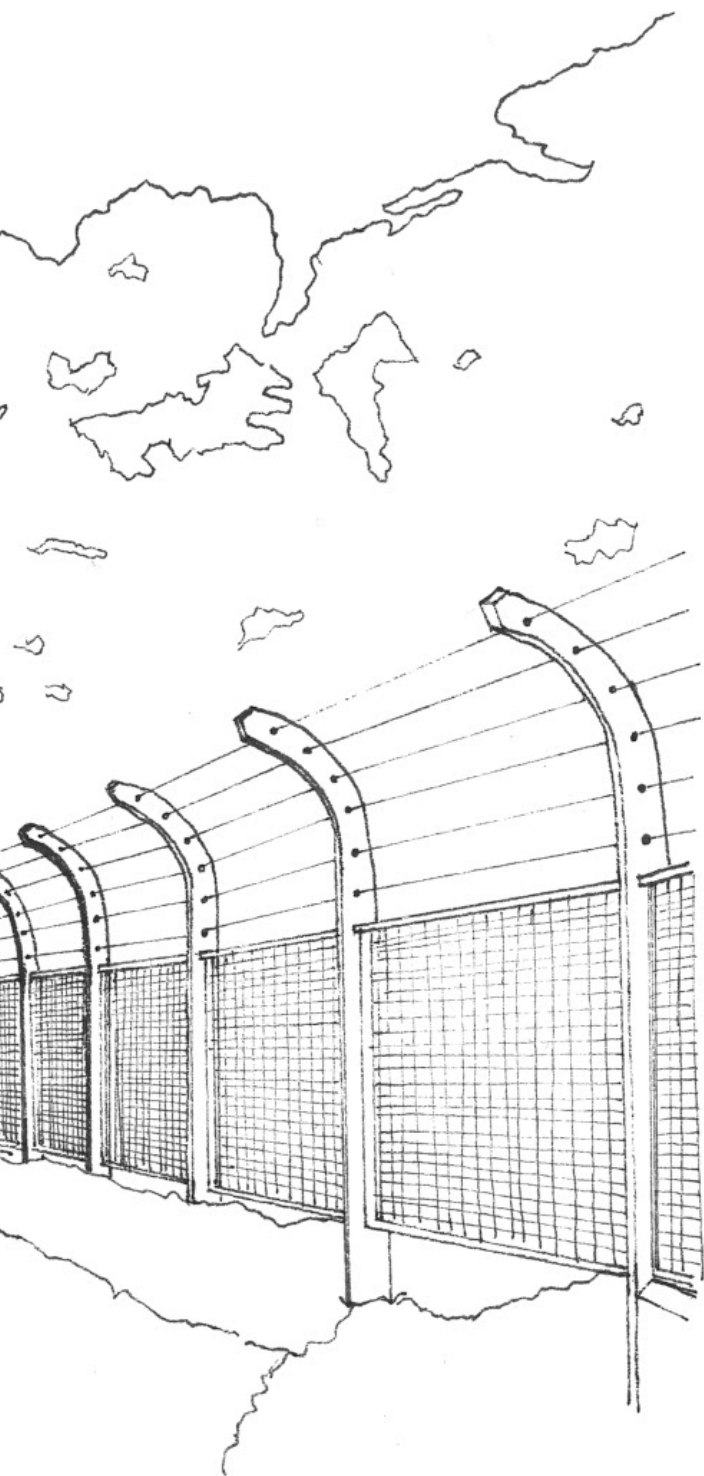

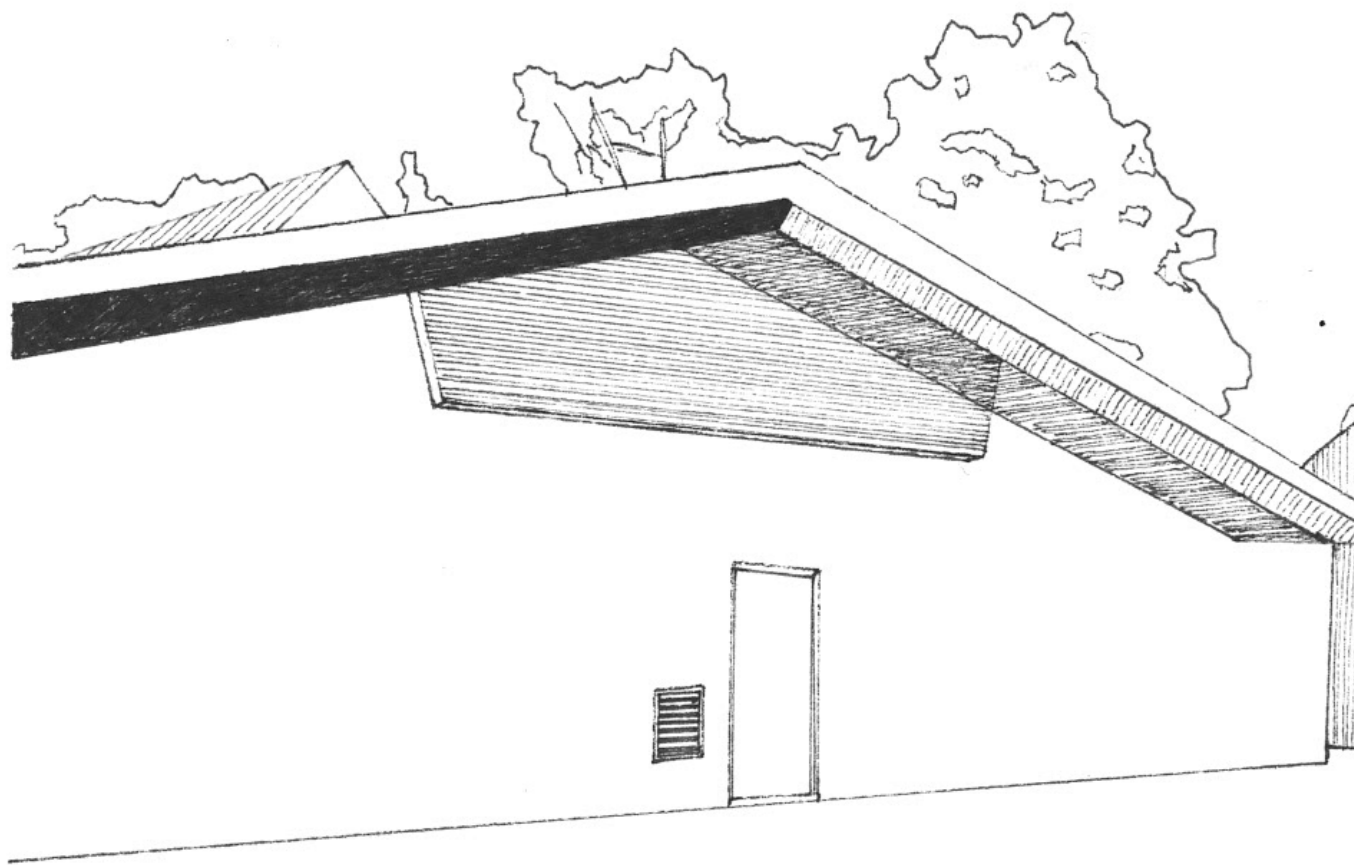

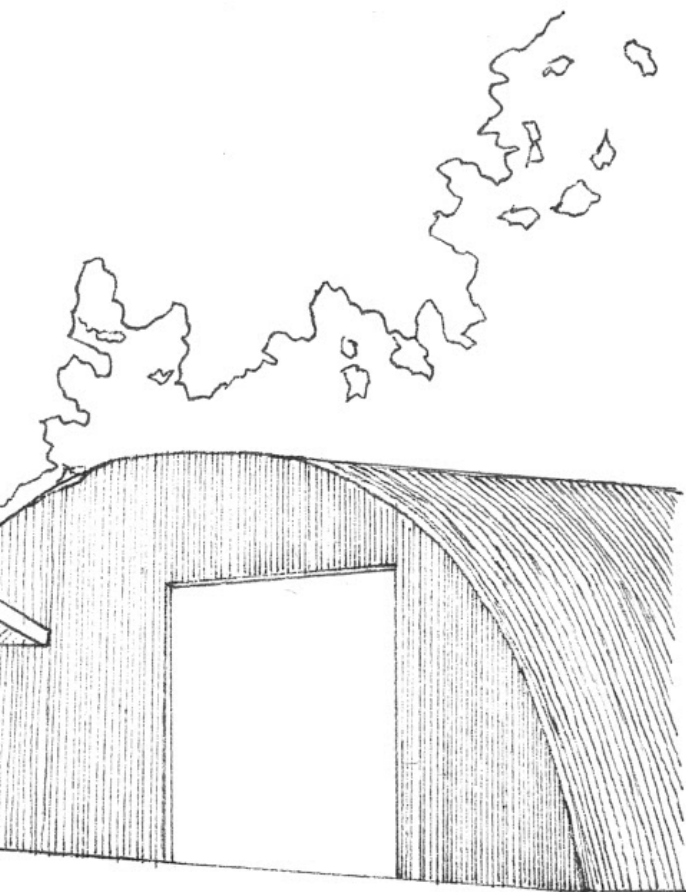

The site currently has the potential to be intricately connected with OMA's art exhibition center. However at the moment, the Romneyloods is obstructing the path. Once this is cleared, the event space that I intend to design can have a direct connection with the future art exhibition center. The functions of my design and OMA's vision can integrate together to create a holistic cultural center for Hembrug.



LEARNING FROM SESC POMPEIA







Project name: Sesc Pompeia Factory

Location: Sao Paulo, Brazil

Architect: Lina Bo Bardi

Built in: 1977-1986

### Introduction

After analyzing the diverse spatial qualities in the Head of the Cape, the next step is to turn these intriguing spaces into a place which signified the reality shaped by intertwining identities, expectations and appropriations, destined for cultural events and social gatherings. Yet, how does a space become a “place”? To answer this question, I therefore looked into a case of physical interventions of heritage buildings that is suitable as references to draw inspiration from, which gave me the concept of creating a flexible cultural hub, that will serve as the primary center for the community of Hembrug and its neighboring areas to accommodate future activities, events and festivities. I have selected Lina Bo Bardi’s work on Sesc Pompeia as a case study and a source of inspiration. I was completely captivated by Bo Bardi’s sensitivity in place-making, and how through means of subtle intervention, she was able to capitalize on the beauty of the steel-drum factory. In the following study, I hope to extract the essence of the strategies that Bo Bardi employed to appropriate space, which has now become the vibrant beacon of Sao Paolo, as a cultural hub that is beloved by many.

*Photo Source:*

*<https://www.sobrevivaemsaopaulo.com.br/2017/09/conheca-9-centros-culturais-com-entrada-gratuita-na-cidade-de-sao-paulo/sesc-pompeia/>*

*“In an overcrowded and insulted city, a sliver of light may suddenly shine, or a breath of breeze arise. Thus, Fabrica da Pompeia is there today, with its thousands of visitors, long lines for draught beer, its pleasant sun deck, and the sports complex: a little cheer in a sad city”*

*– Lina Bo Bardi*

**10.** Self-service restaurant with capacity for 2,000 meals and draught beer hall (at night).

**11.** Industrial-scale kitchen.

**12.** Staff changing room and cafeteria (2 floors).

**13.** Common space for lounge and games, shows and exhibitions, equipped with large hearth and reflecting pool.

**14.** Leisure library, open areas for reading, and video library.

**15.** Exhibition building.

**16.** The center's administrative offices (2 floors).

**1.** Sports complex pool, gym, and courts (5 two-level pavements).

**2.** Cafeteria, changing rooms, and rooms for gymnastics, wrestling, and dancing (11 floors).

**3.** Water tower.

Rua Clélia

16

15

14

16

Rua Barão do Bananal

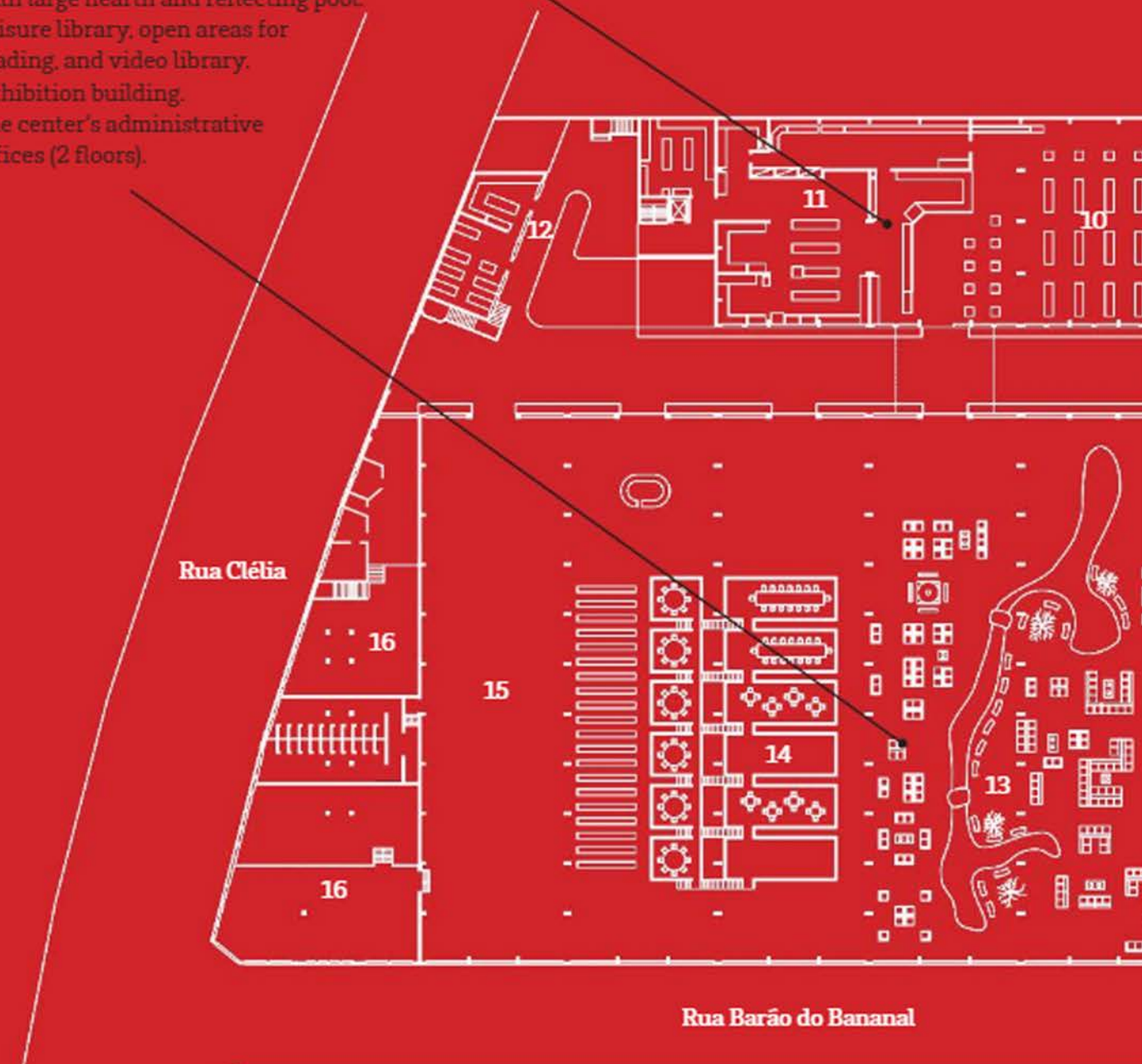



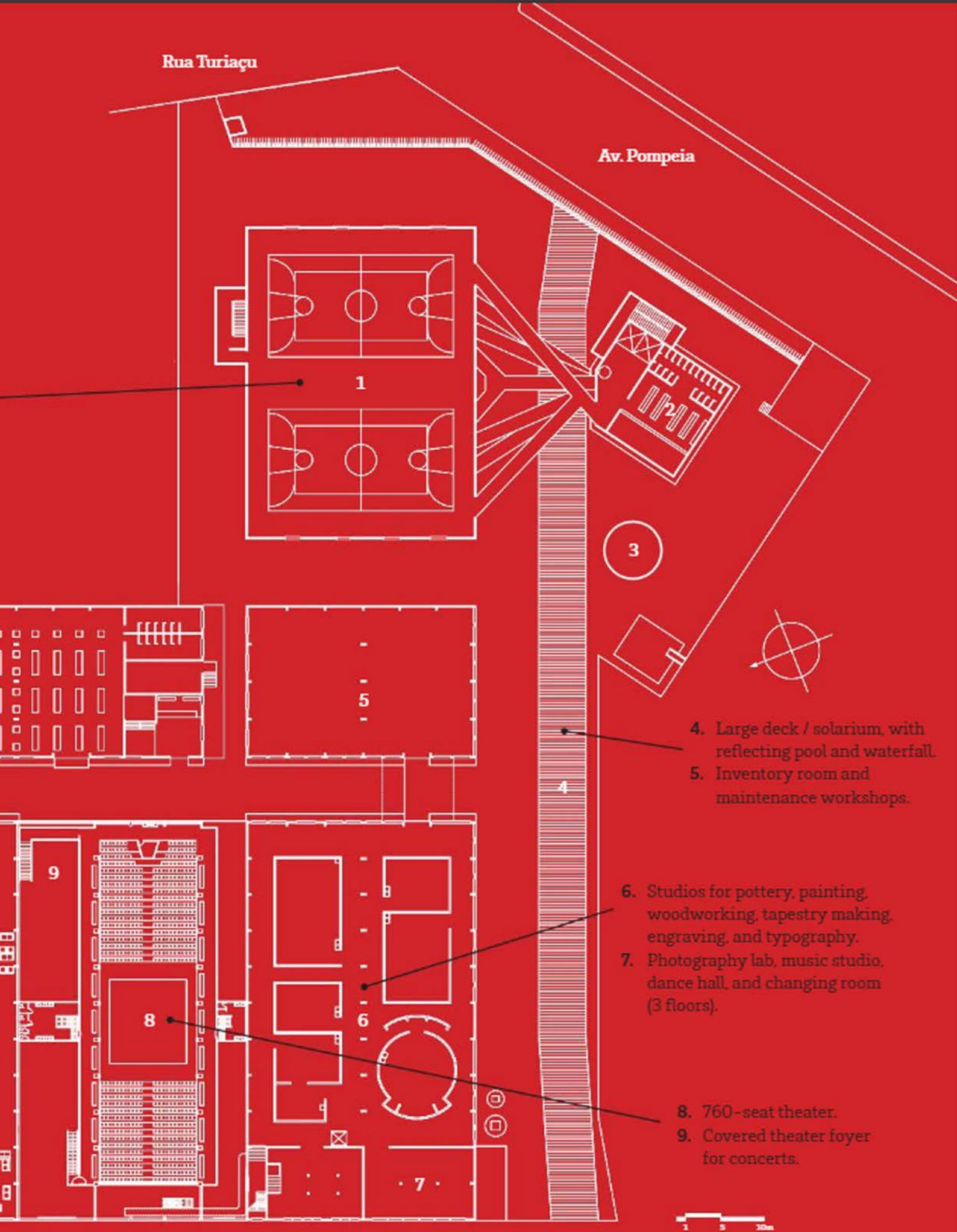

Rua Turiacu

Av. Pompeia

1

3

5

4

4. Large deck / solarium, with reflecting pool and waterfall.  
5. Inventory room and maintenance workshops.

6. Studios for pottery, painting, woodworking, tapestry making, engraving, and typography.  
7. Photography lab, music studio, dance hall, and changing room (3 floors).

8

8. 760-seat theater.  
9. Covered theater foyer for concerts.

7

1 5 10m





**STEEL TRUSS**



**CONCRETE FOYER**



**BITUMEN FLOOR**

**BRICK FLOOR**

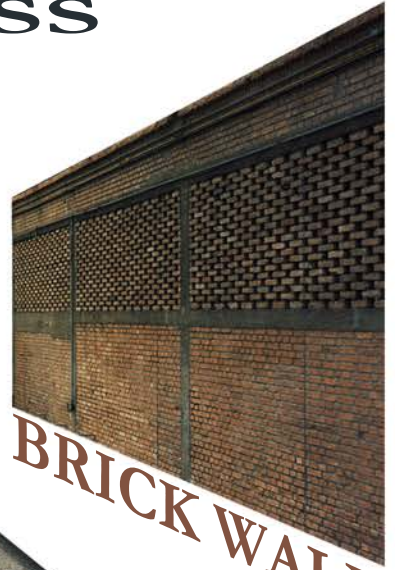

**BRICK WALL**

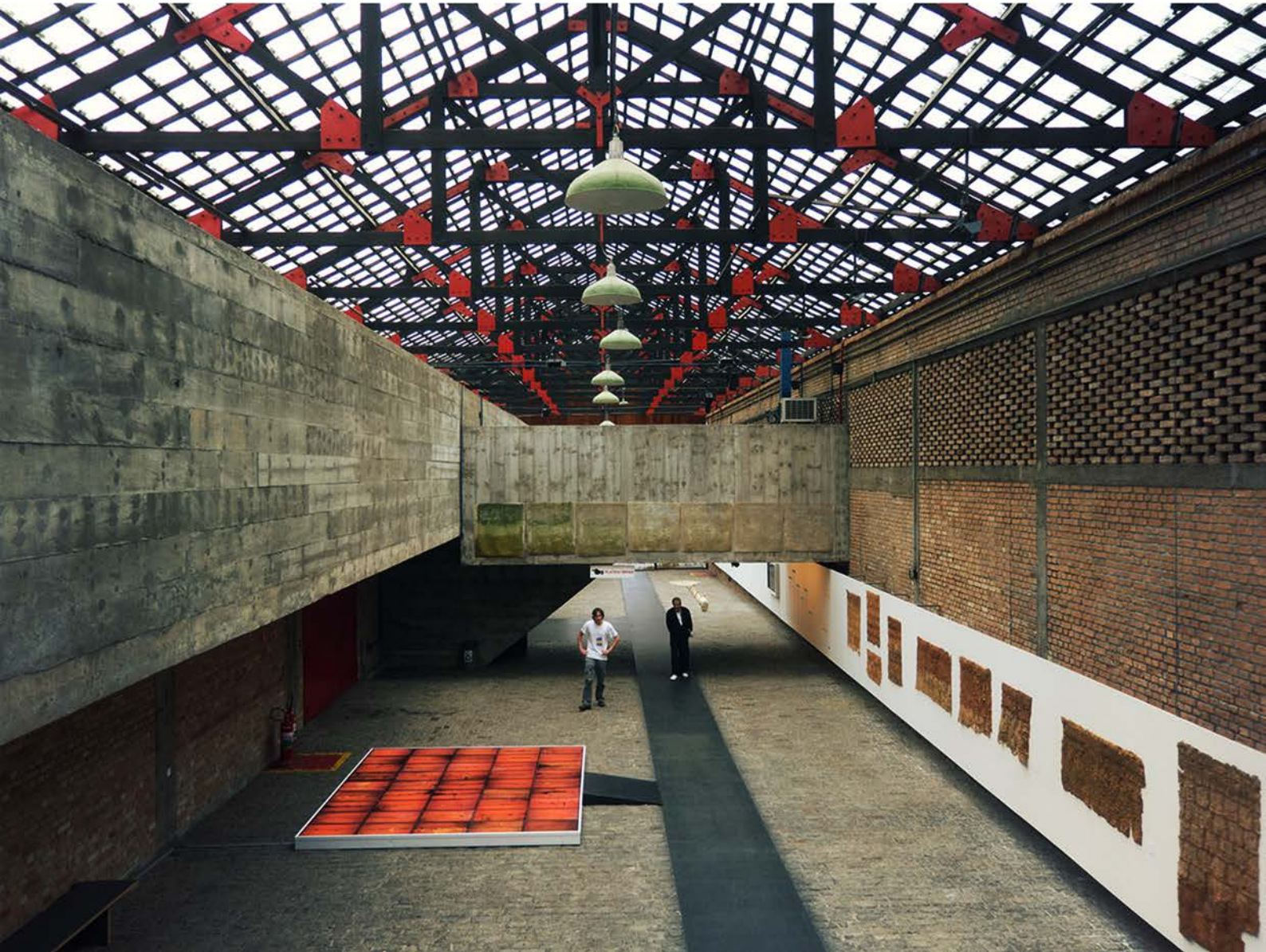

### The truth of structures / materials

One of the many reasons why I selected Bo Bardi's Sesc Pompeia factory as a reference is because she celebrated the aesthetics and structural expression of the steel drum factory, a typology that is atypical of English factories in the early period of industrialization, i.e. the mid-19th century. In the restoration of the steel drum factory, emphasis was put on the industrial components relevant to the century of its making. Heavy-duty and durable materials such as clinkered bricks and bitumen were used to refurbish floors, wooden gates and furniture; steel trusses were expressed proudly. The structures and materials are honestly presented as one entity to their visitors. Lina Bo Bardi made sure that none of the interventions disrupted the open plan of the factory, while at the same time still effectively enriching the spaces.

*Left:*

*Extracted components which express the nature of their materials*

*Photo source:*

*<https://www.archdaily.com.br/01-153205/classicos-da-arquitetura-sesc-pompeia-slash-lina-bo-bardi/52797bb8e8e44e879c000068-classicos-da-arquitetura-sesc-pompeia-slash-lina-bo-bardi-foto>*



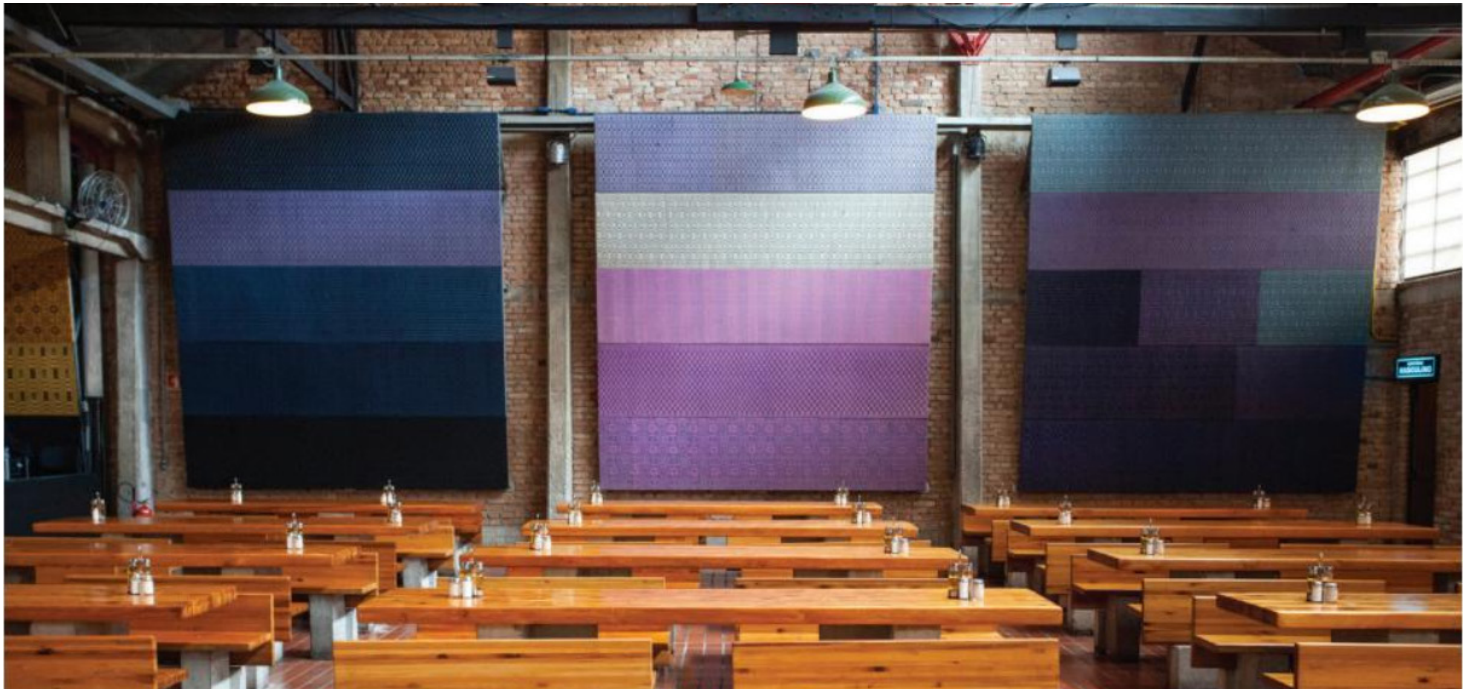
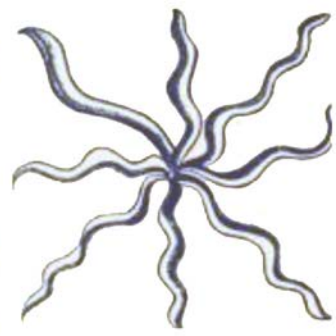

## Dignifying the human condition

### 1. Craftsmanship

One of the key effective strategies that Bo Bardi employed for the intervention of the steel drum factory is her attention to craftsmanship. Tiles for the restaurant and the pool celebrated the Portuguese tradition of painted tiles in buildings, an art form that was inherited by Brazilian architecture. They were commissioned from Rubens Gerchman, a leading artist in Rio de Janeiro. Each tile bore the Brazilian motif, banana leaf in the kitchen and the fish in the pool. The tiles were placed carefully by on site workers. The tapestries hanging on the restaurant's walls were designed by Edmar de Almeida, a visual artist who represented weavers from the Triângulo Mineiro region. The floors of the restaurants are made of colorful ceramic shards, which follows Brazilian tradition of recycling and reusing discarded materials... Bo Bardi's sensitivity towards preserving Brazilian techniques resonates clearly and is highly effective in place-making.

*Top:*

*Brazilian motifs on the tiles, including the banana leaf, seaweed and fish*

*Middle:*

*The tapestries designed by Edmar de Almeida*

*Bottom:*

*The floor made of ceramic shards*

*Source:*

*Sesc Pompeia | Leaflet History | English, Sesc en Sao Paulo, 2013, p.12, 18.*



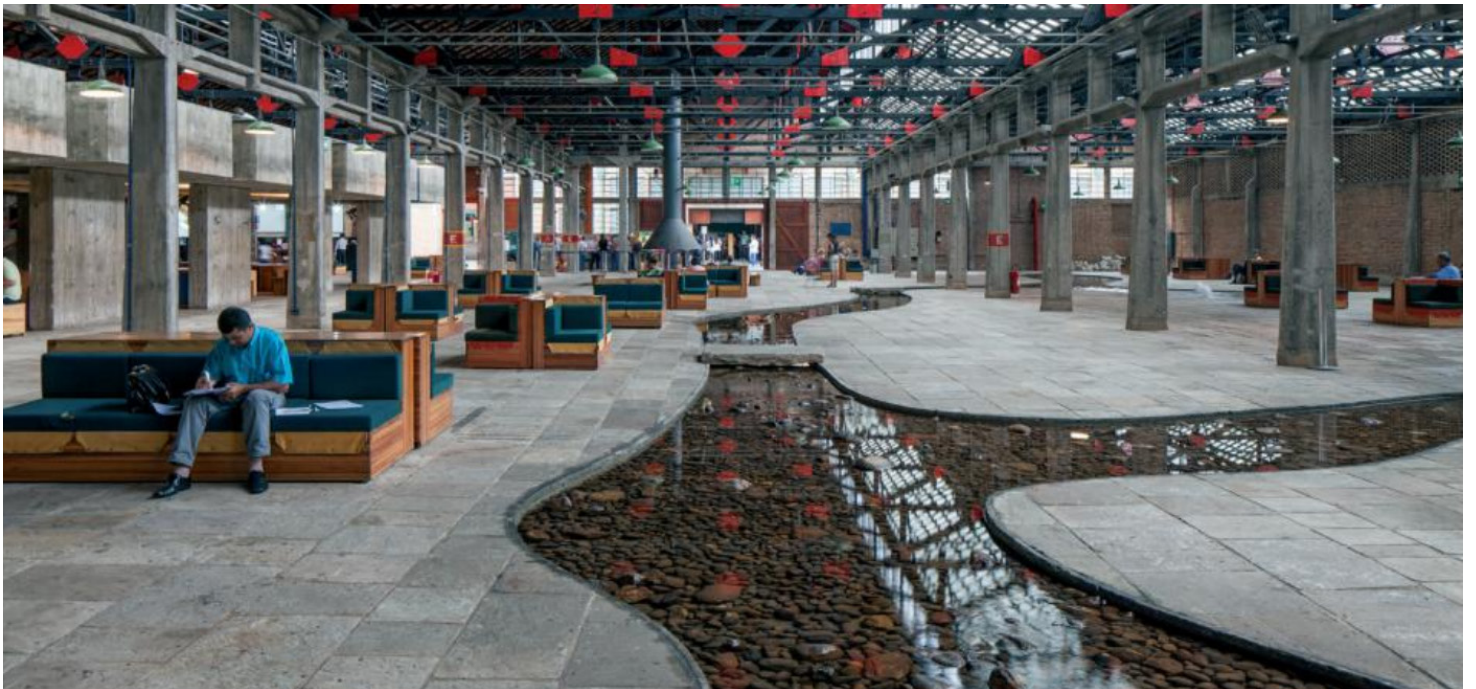
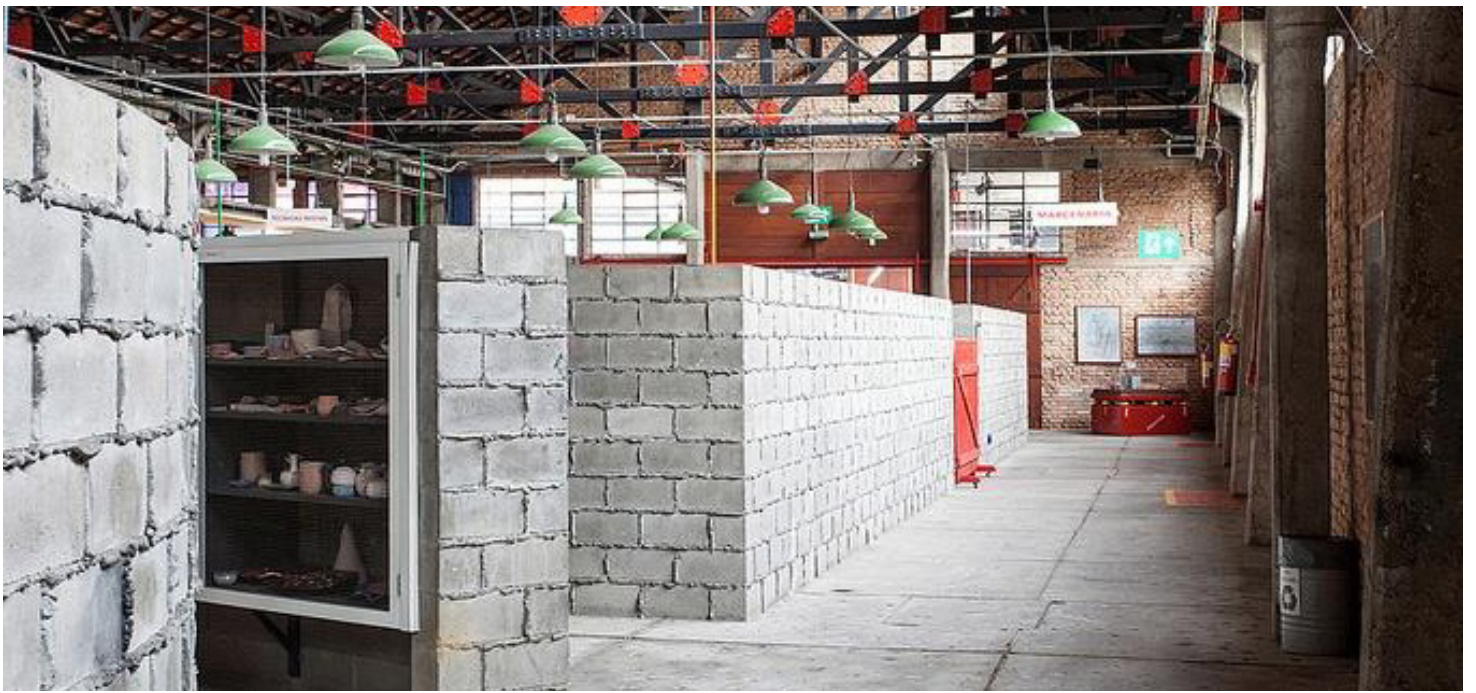



## 2. Sensitivity to the human scale and senses

*“For me, architecture is seeing an elderly man or a child with a plate full of food elegantly crossing our restaurant, looking for a place to sit at a collective table.”*

*-Lina Bo Bardi*

All the interventions that Bo Bardi employed is related to human scale and their senses. The careful placement of low-lying dividing walls, the integration of the water feature in the communal area, the hearth surrounded by wooden benches – every single placement of furniture, of spatial features are thoughtfully interwoven to create human intimacy for the sharing of Brazilian culture.

*Top:*

*The low-lying walls dividing the studio spaces and corridor*

*Middle:*

*The water feature in the communal area*

*Bottom:*

*The hearth surrounded by the wooden benches in the communal area*

*Photo source:*

*Sesc Pompeia | Leaflet History | English, Sesc en Sao Paulo, 2013, p.14, 15, 23.*

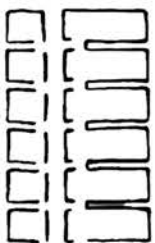
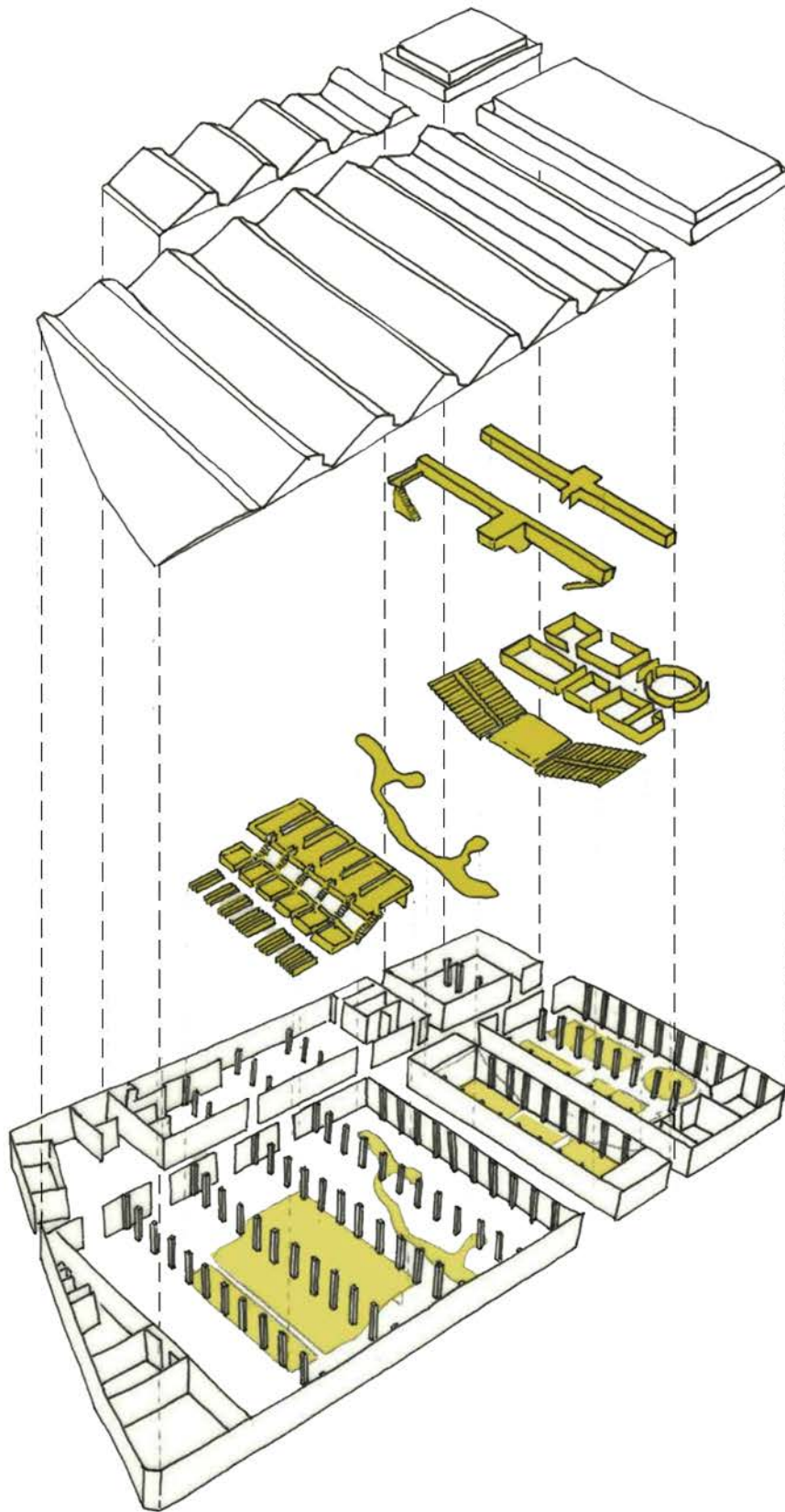

*Leisure Library*



*Communal area*

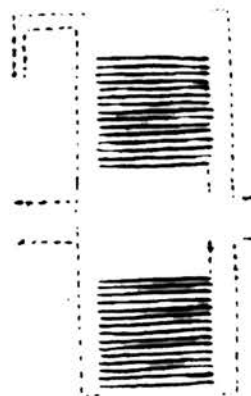

*Theater*

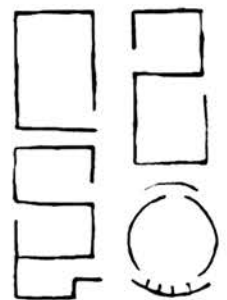

*Studios*

### 3. Program arrangement

The selection of programs was also vital for the revitalization of the factory. Through the integration of the theatre, studios for painting, woodworking, tapestry making, engraving etc, the leisure library, common spaces and a variety of sports facilities, Sesc Pompeia has become a vibrant hub where the public can engage in community building activities.

*Top:*

*Axometric of the Sesc Pompeia factory complex*

*Bottom:*

*The essence of the four programs:*

- 1. The pocket spaces for leisure library*
- 2. The water feature in the communal area*
- 3. The theater and foyer*
- 4. The studios for painting, woodworking, tapestry making and engraving*

*Illustration source:*

*Javier Corzán, La Fábrica del Pueblo - Sesc Pompeia, 2013, p. 21, 23.*



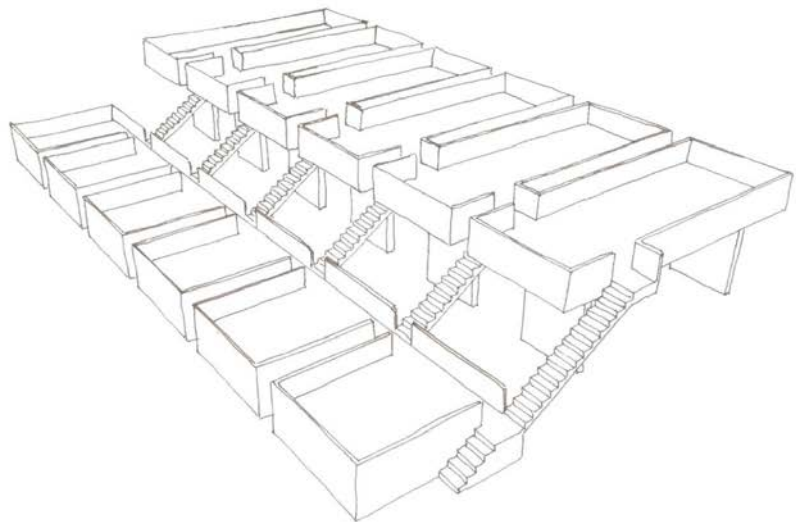
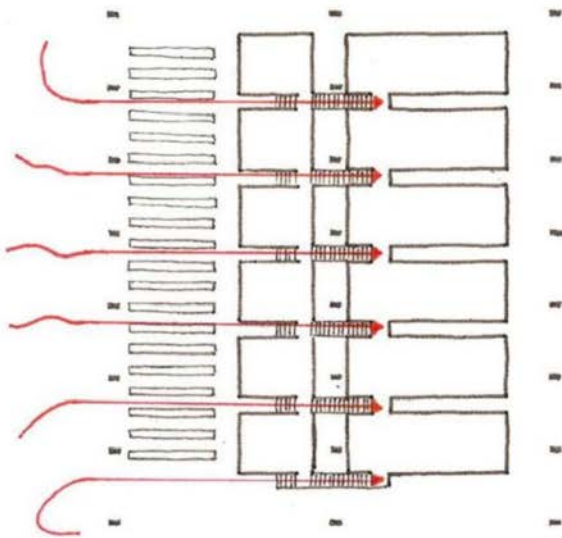

### **Leisure Library**

The library is compartmentalized into cubicles with low lying concrete partitions and wood furniture. The concrete cultivates the raw atmosphere of the factory, while the wooden elements creates a warm atmosphere for people to engage in more intimate activity. There are three levels, the ground level is for watching TV, the middle level is for reading while the upper level is the cultural area which has a broader view towards the heart of the factory.

*Top:*

*Lower cubicles of the leisure library*

*Bottom left:*

*Three areas segregated by levels*

*Bottom right:*

*The two levels of the leisure library*

*Photo source:*

*<https://www.flickr.com/>*

*photos/22562291@N04/15012929915*

*Illustration source:*

*Javier Corzán, La Fábrica del Pueblo - Sesc Pompeia, 2013, p. 31, 33.*



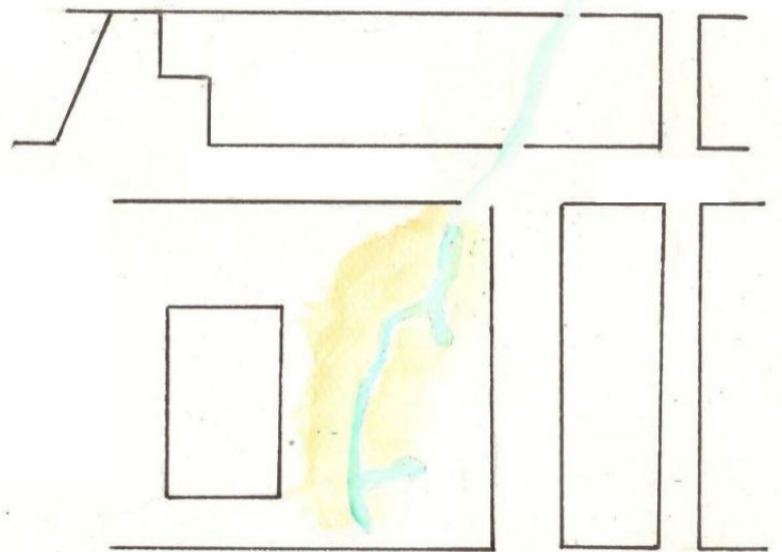



### **The Communal Area**

In the district of Pompeia, there is a nearby river where people drink from. Bo Bardi incorporates this feature into the factory through the water element in the communal area.

*Top:*

*The water feature in the communal area*

*Bottom left:*

*The nearby river that people drink from.  
Site indicated in red color.*

*Bottom right:*

*Bo Bardi introduces the water element  
into the factory*

*Photo source:*

*<http://infoartsp.com.br/guia/museus-e-instituicoes/sesc-pompeia/>*

*Illustration source:*

*Javier Corzán, *La Fábrica del Pueblo - Sesc Pompeia*, 2013, p. 13.*

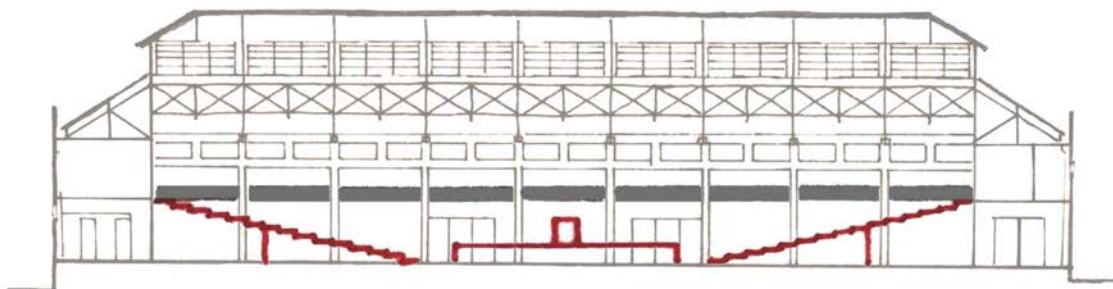
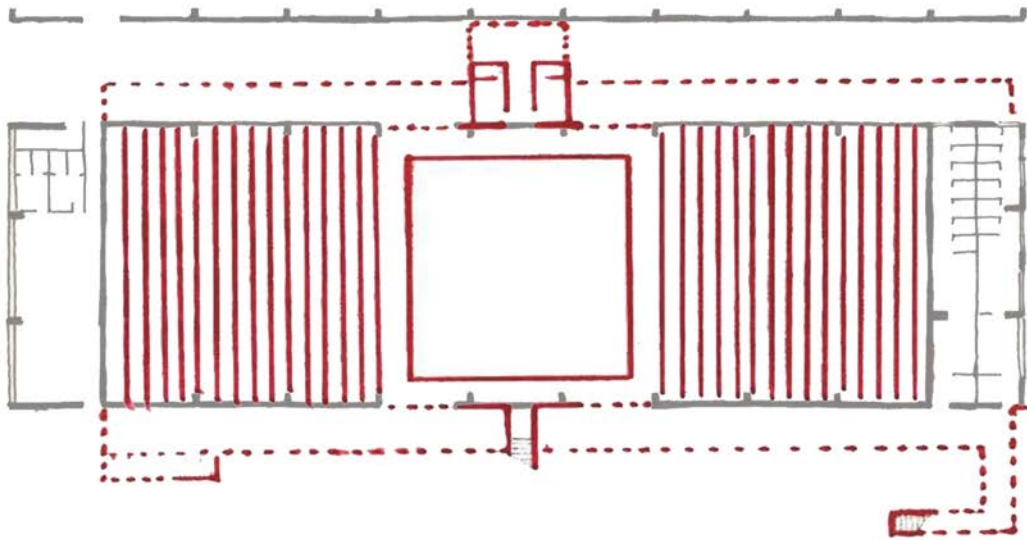

## The Theater

*“Theater is life, and in the absence of ‘predetermined’ givens, an open and unassuming set design lets viewers be creative and ‘participate’ in the existential act of a theatrical spectacle. As for the all-wooden seating with no upholstery, note that medieval mysteries or morality plays were staged in streets or in squares, where the audience stood or walked around them. Greco-Roman theaters were in the open air, no upholstery, just bare stone. Audiences got soaked, just like the bleachers at soccer stadiums today, which also lack upholstery... The Pompeia theater has wooden seating in an attempt to give back the playhouse its power of ‘estranging and engaging,’ rather than have people just sit there.”*

*-Lina Bo Bardi*

Taking advantage of the larger bay and the two adjacent corridors, Bo Bardi created a theatrical space. The central stage and the bleachers on each side of the room is an optimal area for performances and events to be held.

*Top:*

*The theater with wooden seating on two sides*

*Middle:*

*Plan of the theater, seating and stage are indicated with red solid lines while the foyer is indicated with red dotted lines*

*Bottom:*

*Section of the theater, seating and stage are indicated with red solid lines while the foyer is indicated with grey color*

*Photo source:*

*<https://en.wikiarquitectura.com/building/sesc-pompeia-factory/>*

*Illustration source:*

*Javier Corzán, La Fábrica del Pueblo - Sesc Pompeia, 2013, p. 37.*



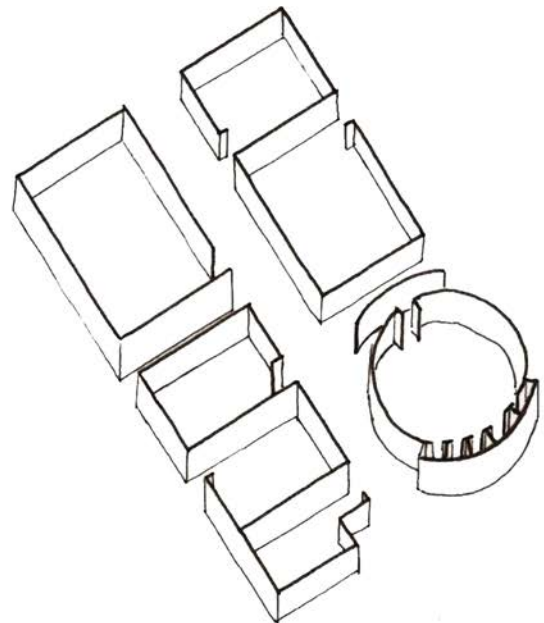
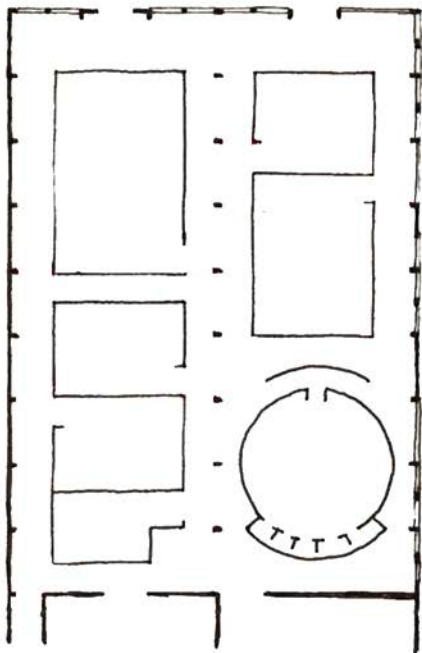

### **The Studios**

Similar to the library, the studio space capitalizes on the existing structure of the factory without diffusing its original spatial quality. Bo Bardi's introduction of a low-lying circular space creates a duality with the orthogonal confines of the space, providing a friendly space for different types of cultural activity to take place, for instance painting, woodworking, tapestry making, engraving and etc.

*Top:*

*The circular workshop area for ceramics and pottery making*

*Bottom:*

*Plan and axonometric of the studio spaces created by the concrete low-lying walls*

*Illustration source:*

*Javier Corzán, La Fábrica del Pueblo - Sesc Pompeia, 2013, p. 45.*

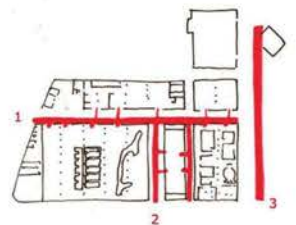
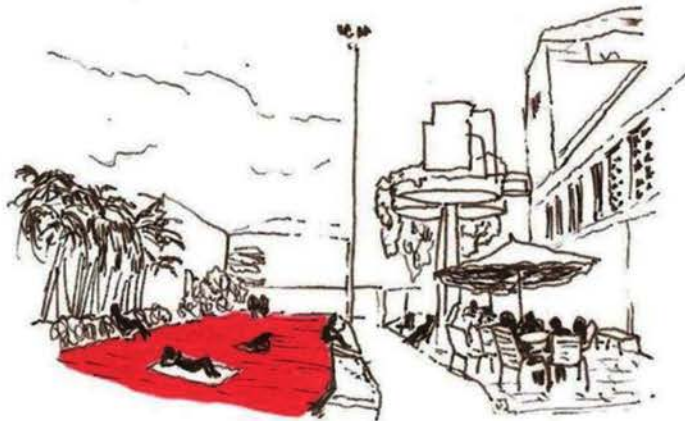
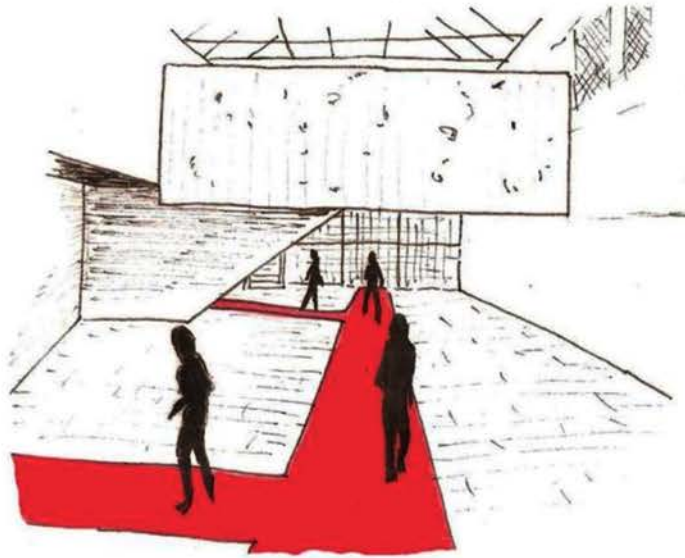



**Spatial quality**

To reflect the busy streets of Pompeia, Bo Bardi creates a series of narrow corridors defined by polished concrete to direct the movement of the public.

These corridors link closely with the areas full of dynamic activities.

*Top:*

*The narrow street that leads to the restaurant on the left and main factory hall on the right*

*Middle:*

*The internal "street" between the communal area and the theater.*

*Bottom:*

*The outdoor wooden sun deck heading to the direction of the sports complex*

*Illustration source:*

*Javier Corzán, La Fábrica del Pueblo - Sesc Pompeia, 2013, p. 55.*

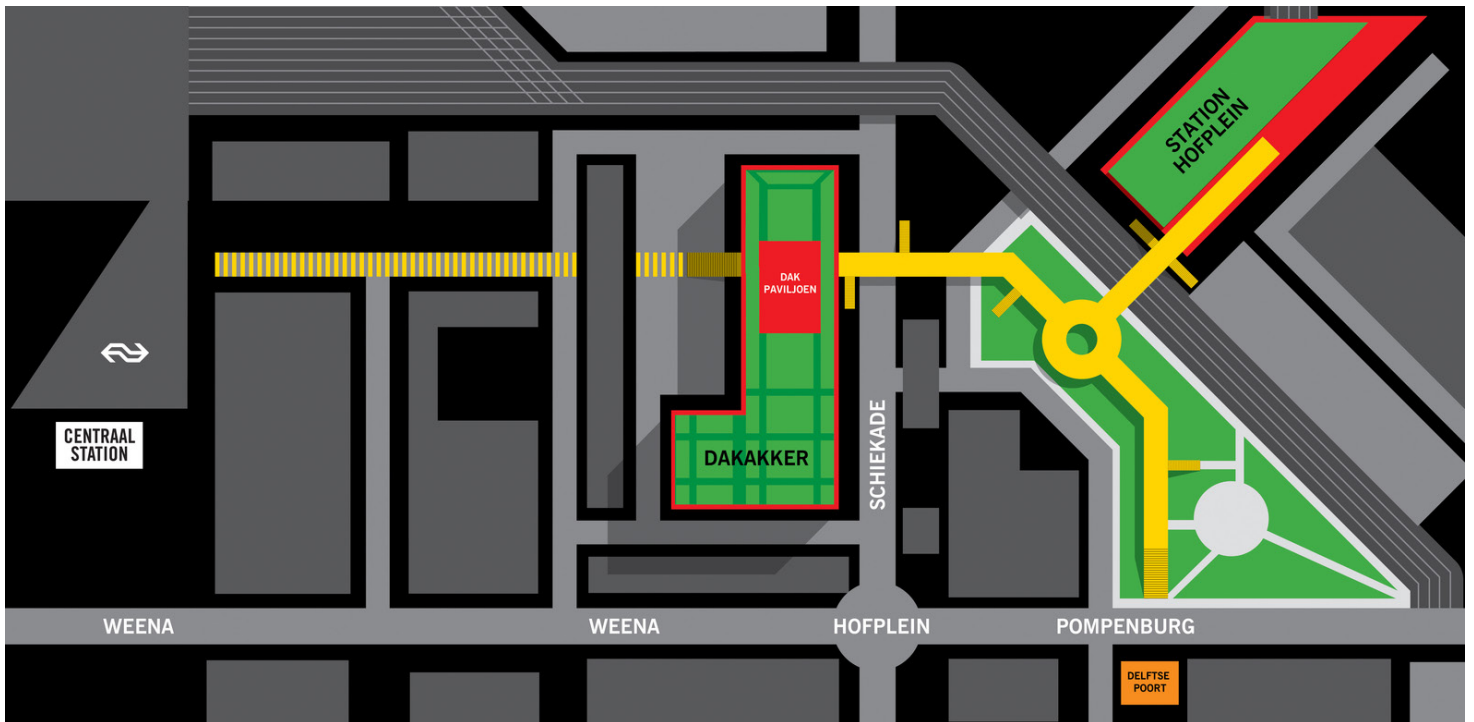
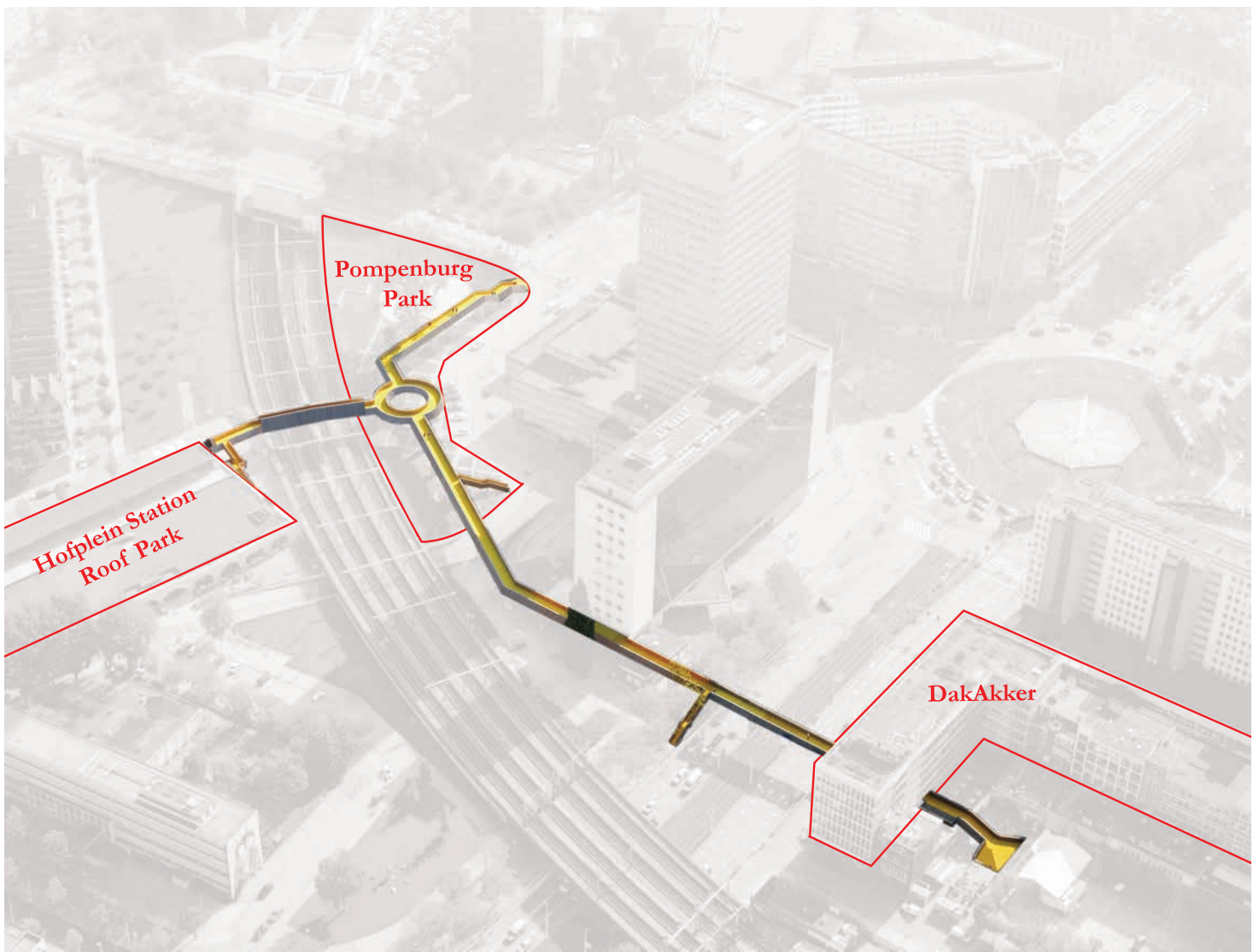

Legend:

 Luchtsingel

# LEARNING FROM DE LUCHTSINGEL

Project name: De Luchtsingel  
 Location: Rotterdam, Netherlands  
 Architect: ZUS  
 Built in: 2015

*Top:*  
 ZUS activates the three areas in the heart of Rotterdam by simply building a yellow bridge

*Bottom:*  
 Plan of the Luchtsingel

*Source:*  
<https://www.archdaily.com/770488/the-luchtsingel-zus>

*“Based on the idea of Permanent Temporality, the Luchtsingel introduces a new way of making city. This means using the city’s evolutionary character and existing forms as a starting point. Therefore, we have developed new instruments for design, financing, and planning”*

*-Elma van Boxes, partner at ZUS*

Initiated and designed by the Rotterdam-based architects ZUS, the Luchtsingel is built in 2015 with the aim to connect three districts in the heart of Rotterdam. Together with the new public spaces, including the Delftsehof, Dakakker, Pompenburg Park, and the Hofplein Station Roof Park, a ‘three-dimensional cityscape’ has arisen. These varied and new public spaces return this former heart of Rotterdam back to being green and livable, with the Luchtsingel running throughout as a unifying factor. By simply increasing accessibility for pedestrians, the 400-meter-long bridge will ensure synergy between the various sites.

This precedent study inspires me how a single simple idea can activate the potential of a large area. By building a distinctive yellow path, the luchtsingel gives the area a unique position in Rotterdam’s urban fabric.



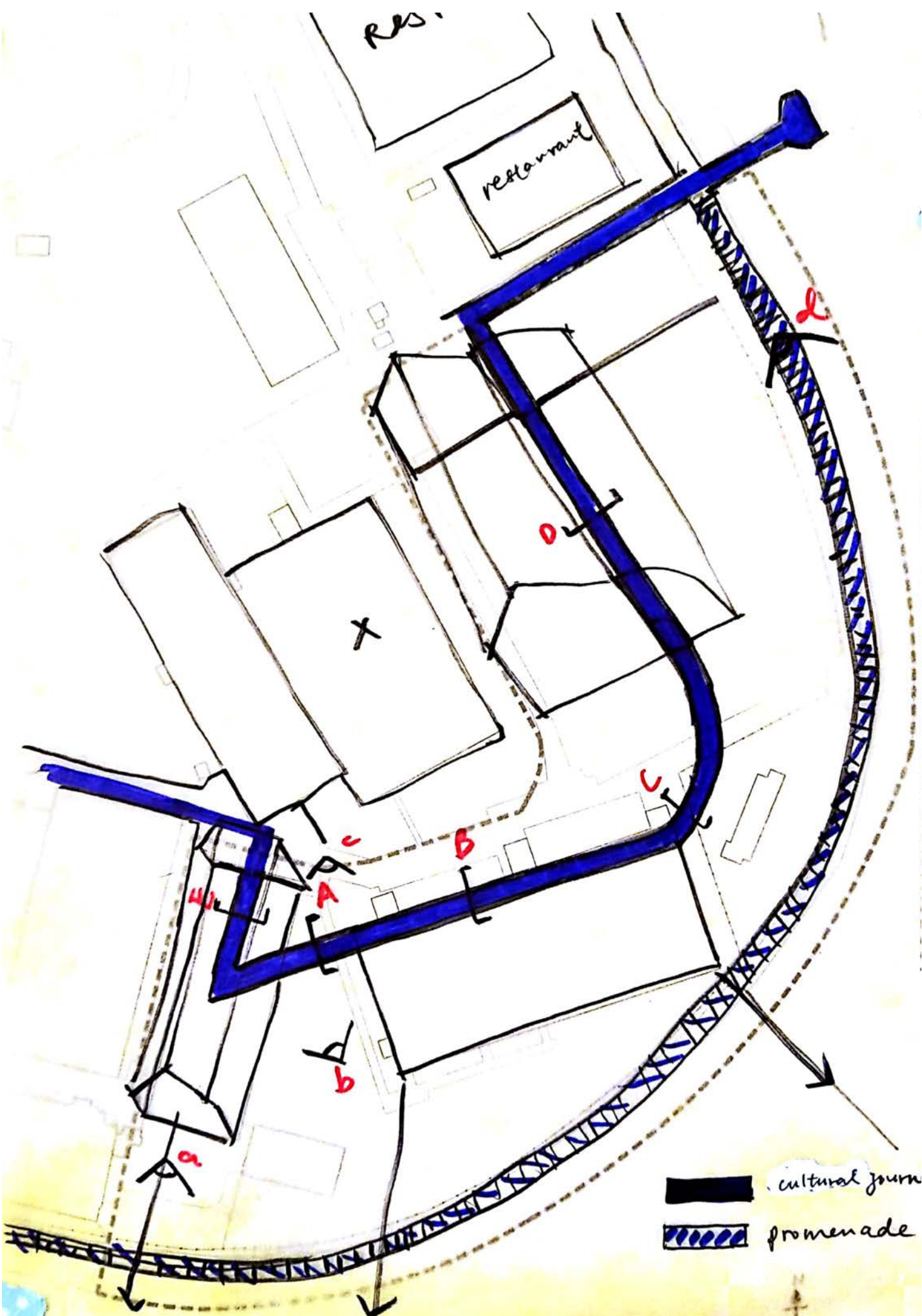

— cultural journey  
▨ promenade

## DESIGN PROCESS

One of the key elements of the design is the passage that links all the heritage building in the site, namely the projectile workshop, the ammunition factory and the commander bunker. There are 2 defined passages, each with a different purpose.

The inner passage reflects the cultural history of Hembrug. As the entrance point from the main road, Middenweg, the inner passage begins from the projectile workshop - reprogrammed as the ticket office/exhibition space (section E). The journey is framed by the structural system of the curved shell roof typology, which first leads into the rear-corridor of the ammunition factory with side openings to the main space (section B) - a restaurant/cafe that opens up to the sea front. Upon exiting the ammunition factory, the guests arrive at an outdoor space framed to view the commander bunker (section C) where they can choose to access according to their interest. The inner passage ends with the main event space (section D), a black box theater that can also open to the seafront.

The inner passage links with the outer passage at the exit of the black box theater, as they arrive at the pier. The guests passage represents the future of what Hembrug can become, as the visitors arrive at their final destination, a promenade that completely expands into the canal-front. This outdoor space by the promenade is shared by all of the buildings, and has a direct link with OMA's cultural center.

### *Sketch:*

*The inner passage creates a cultural journey of Hembrug's history while the outer passage acts as a promenade and event space. Together they activate the Head of the Cape.*

### *Abstract diagram:*

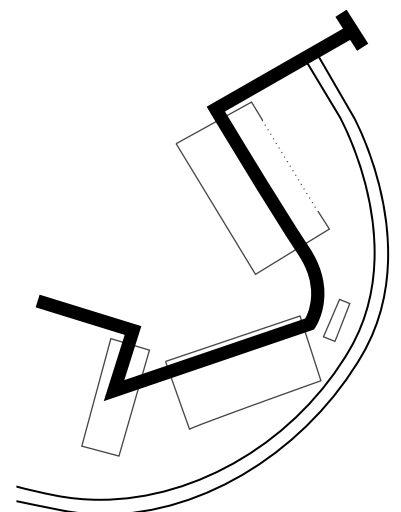

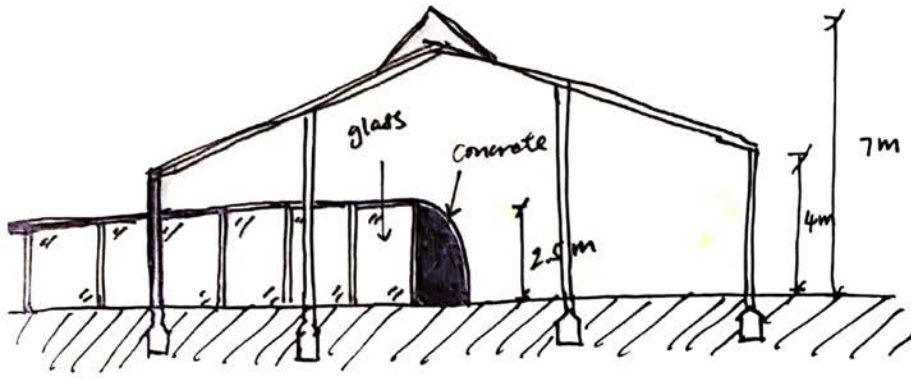

Inside the projectile  
workshop  
Section E



The passage to  
the ammunition factory  
Section A

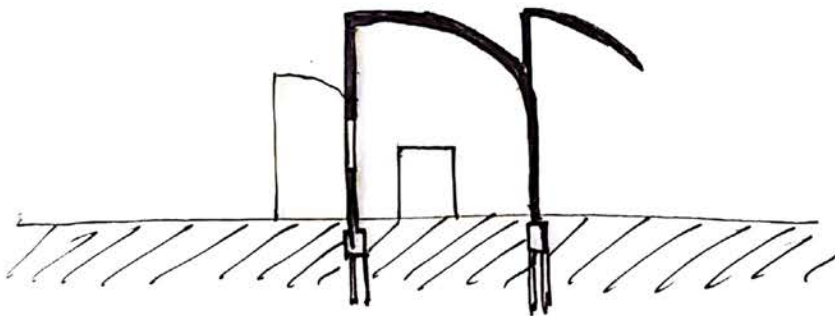

Inside the ammunition  
factory  
Section B



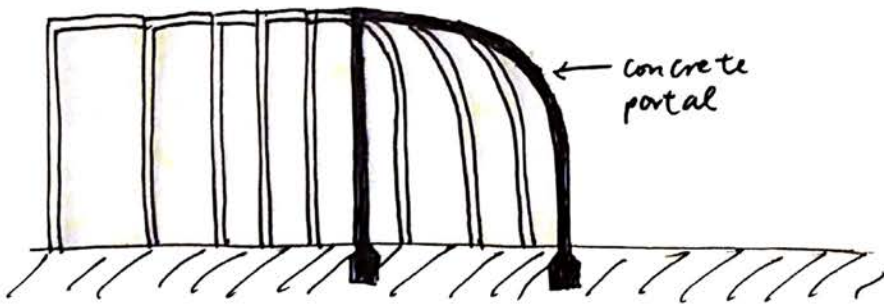

The passage

Section C

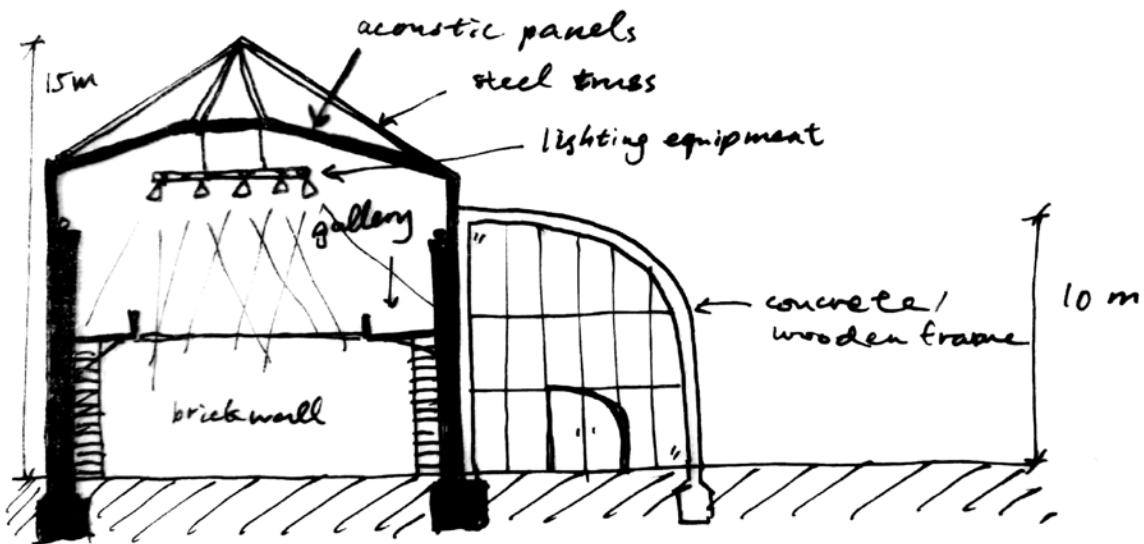

Section D

Section E: The passage is inserted into the projectile workshop

Section A: The passage connects the projectile workshop and the ammunition factory

Section B: The cultural journey continues inside the ammunition factory

Section C: The passage is composed with the structural element of the ammunition factory, i.e. the curved portal frame

Section D: The theater has an open plan to cater different genres of performances or cultural activities

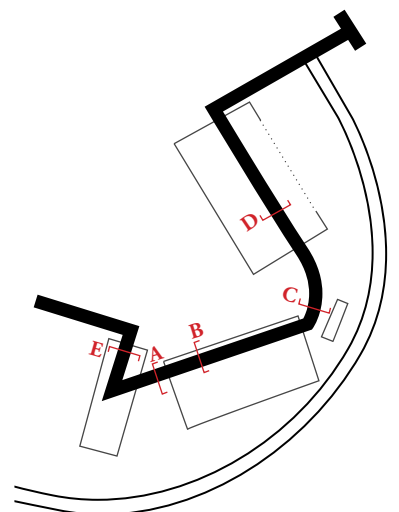

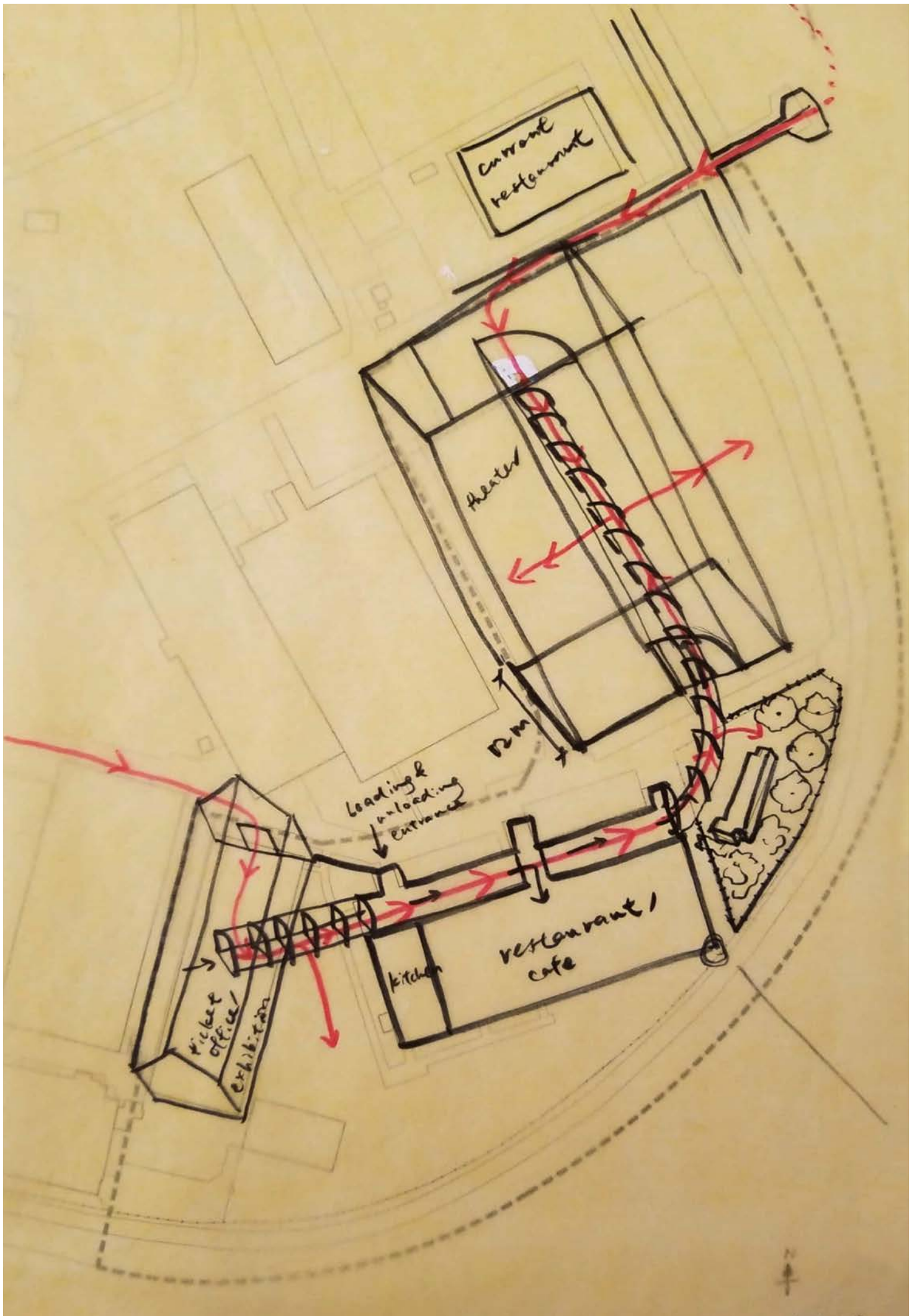

# THE PAST AND THE FUTURE

## *The Cultural History of Hembrug*

The inner passage was inspired by the Luchtsingel project by ZUS. Instead of using the color yellow as a symbolic representation of an infrastructure that ties the residual spaces near Rotterdam Centraal station together, I instead used a the structural system derived from the curved roof typology to create the linkage of all the heritage buildings. The structural system is expressed in a bold manner consistent with the concrete material and framing strategy employed in the 1950's so that when the guests journey through the passage, they walk back in time to Hembrug's history.

As mentioned in the introduction, the inner passage begins from the old projectile workshop. The framing system of the inner passage intrudes into the wall of the projectile workshop, such that from the entrance, it is clear that there is an initiation path, and they are lured into beginning their journey down the memory lane of Hembrug.

The inner passage connects with the rear end of the ammunition factory. This passageway is completely preserved in both material and structural system (concrete partition wall and infill brick wall), which was traditionally used to be the circulation path for bringing in the ammunition to be stored or processed in the factory. There is an opening into the main space of the factory, which will be transformed into a restaurant/cafe with a framed view of the sea-front.

As the guests exit the factory, they are once again walking down the corridor defined by the curved roof structural system. Much like a Roman loggia, this corridor is permeable and they can access the outdoor space which leads to the commander bunker. Here they can step inside the commander bunker where they can have an accurate spatial experience of what it is like to be inside during wartime.

When the guests enter into the black box theater, the curved roof system continues, but is framed by a magnified version. The interior space suddenly expands many fold to unveil a huge interior event space perfect for performances.

*Sketch:*

*The inner passage made of the curved portal frame from the curve shell roof typology*



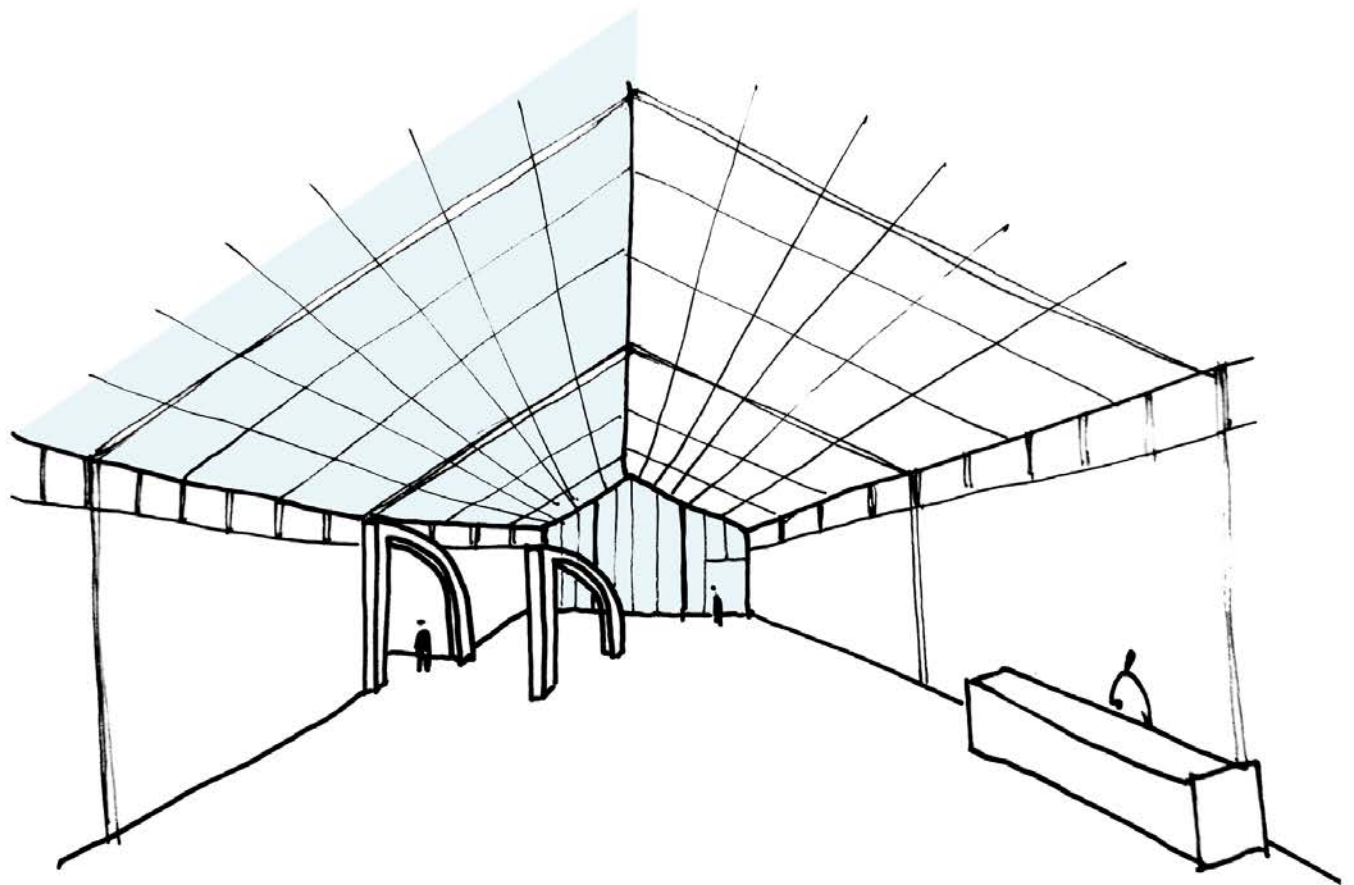
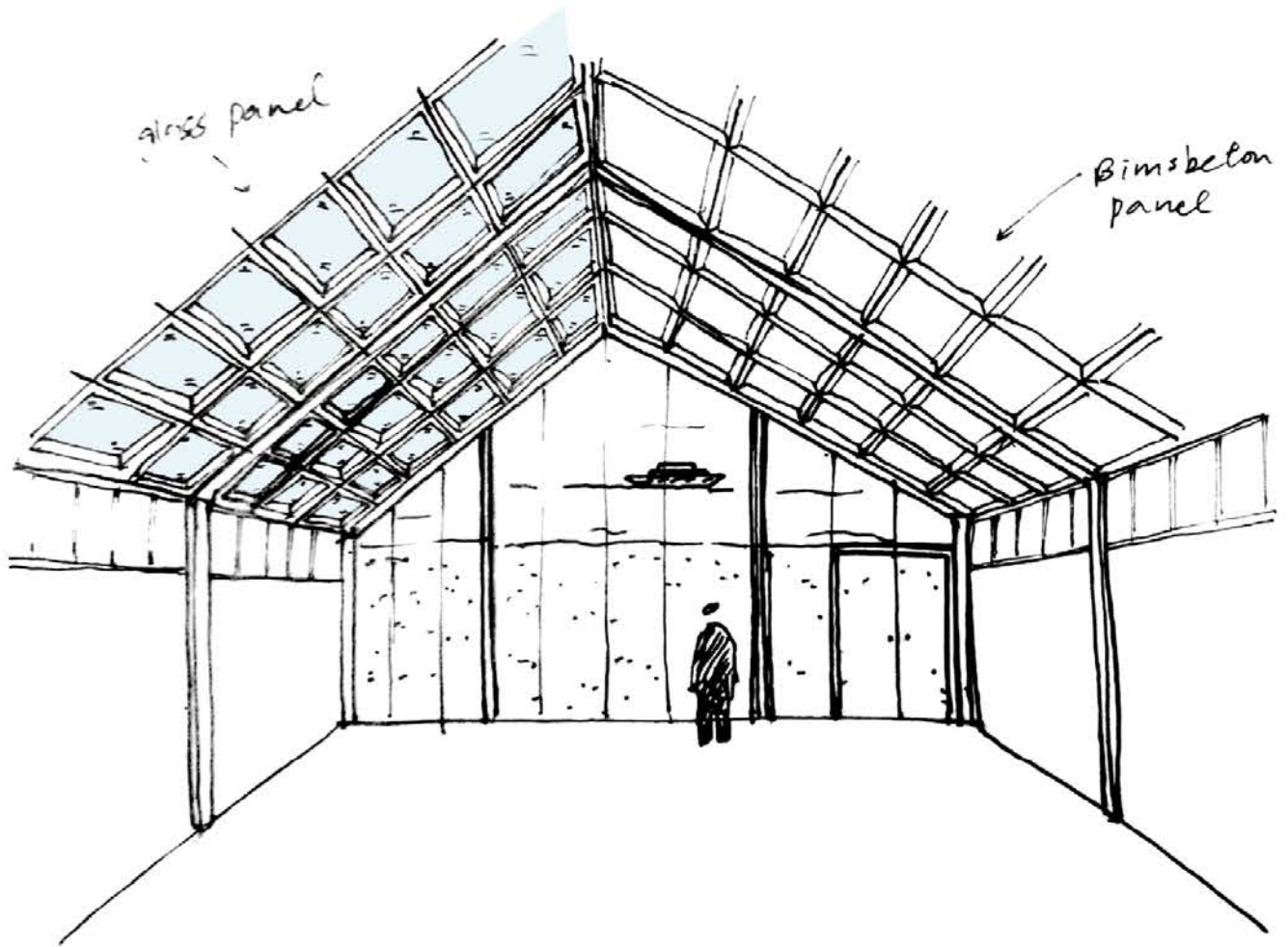

***Perspective A:***

The projectile workshop will be renovated such that the East facing part of the pitched roof will be replaced with glass panels to allow sunlight in. Furthermore, the south facing facade will be replaced with a glass curtain wall so that it completely opens up visually to the water-front.

***Perspective A1:***

The intrusion of the curved roof structural system into the projectile workshop marks the beginning of the historic journey. The skeletal frame suggests the pathway, but does not impede on the spatial quality of the original building.

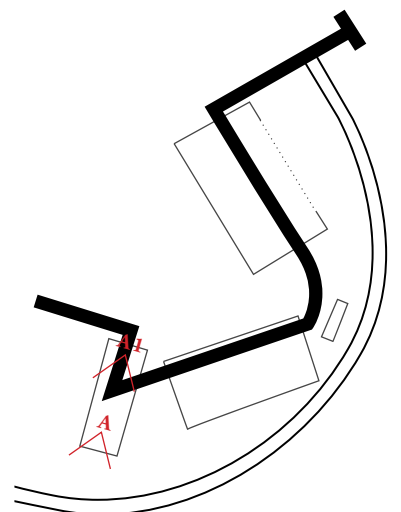
*Top:**Perspective A**Projectile workshop: South facade opening up to the water-front.**Bottom:**Perspective A1**The curved portal frame hints the beginning of the journey.*

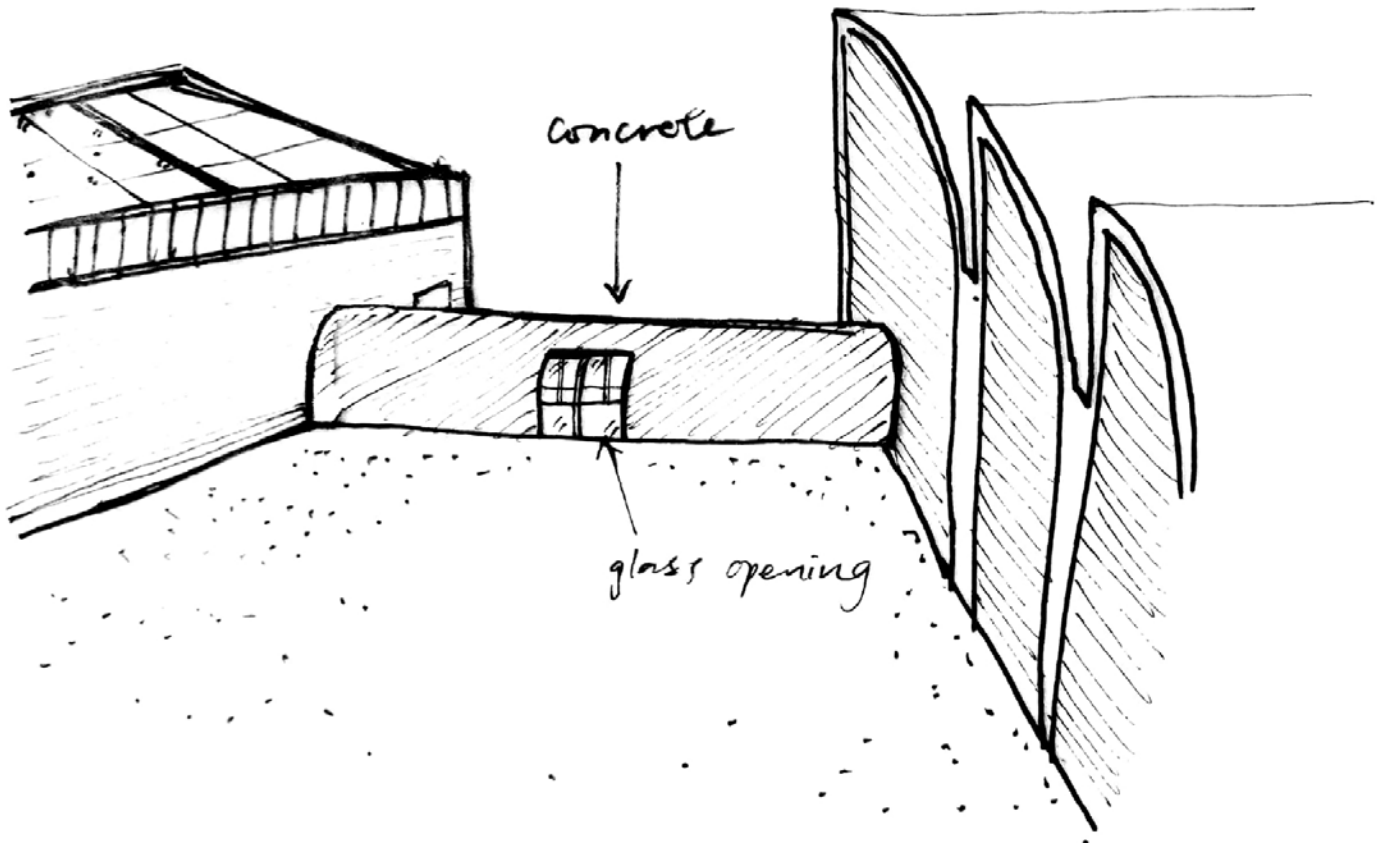
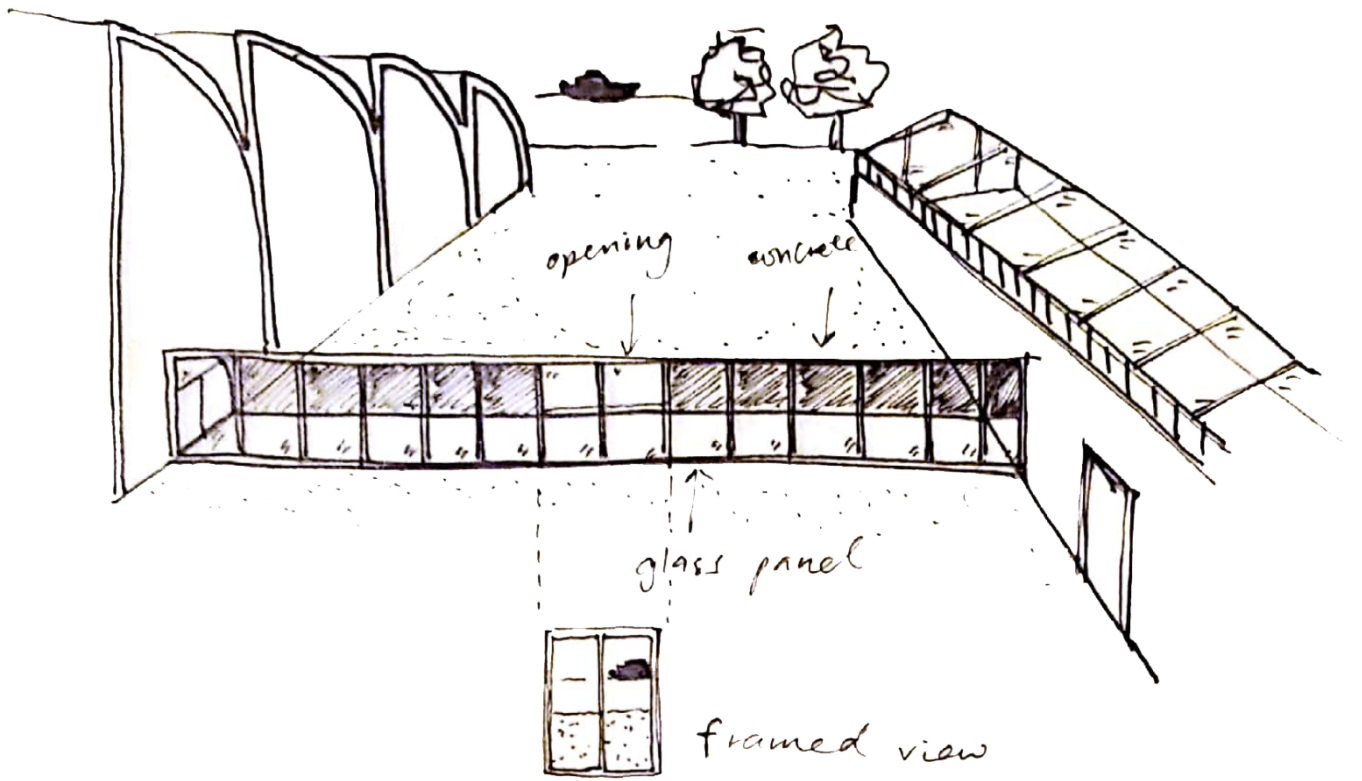



***Perspectives B and C:***

When the guest walks down from Middenweg, they already see the passageway that connects the projectile workshop with the ammunition factory. The facade facing Middenweg is made of glass so that the guests can see the movement of the people, which suggests that there is a journey (perspective B). The mystery of the journey is maintained by the concrete facade facing the water-front, which can only be accessed once you enter the projectile workshop (perspective C).

*Top:*  
*Perspective B*  
*Perspective of passage viewing from the Middenweg*

*Bottom:*  
*Perspective C*  
*Perspective of passageway from water-front.*

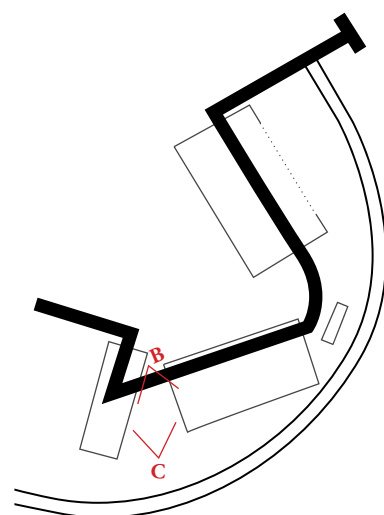

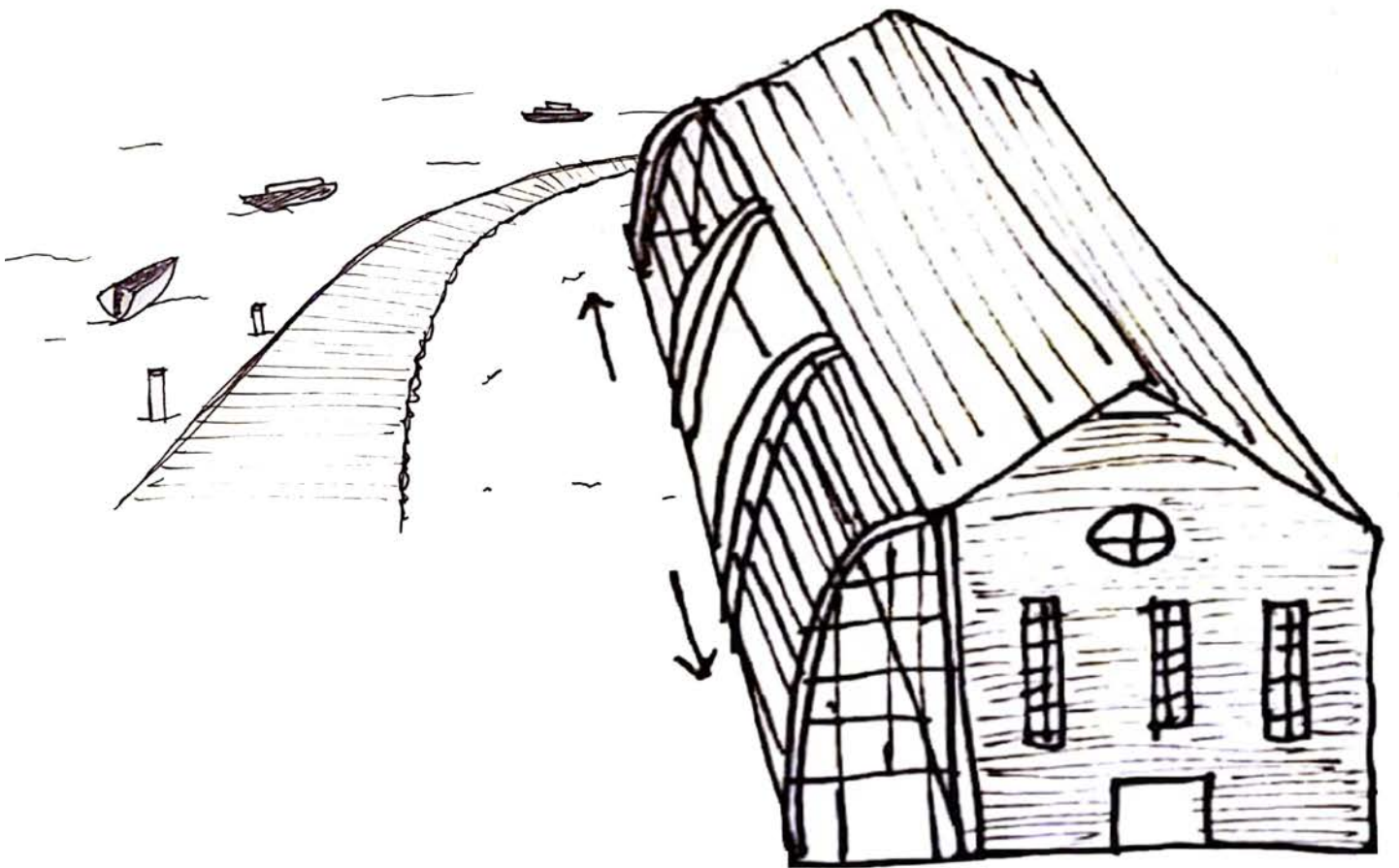
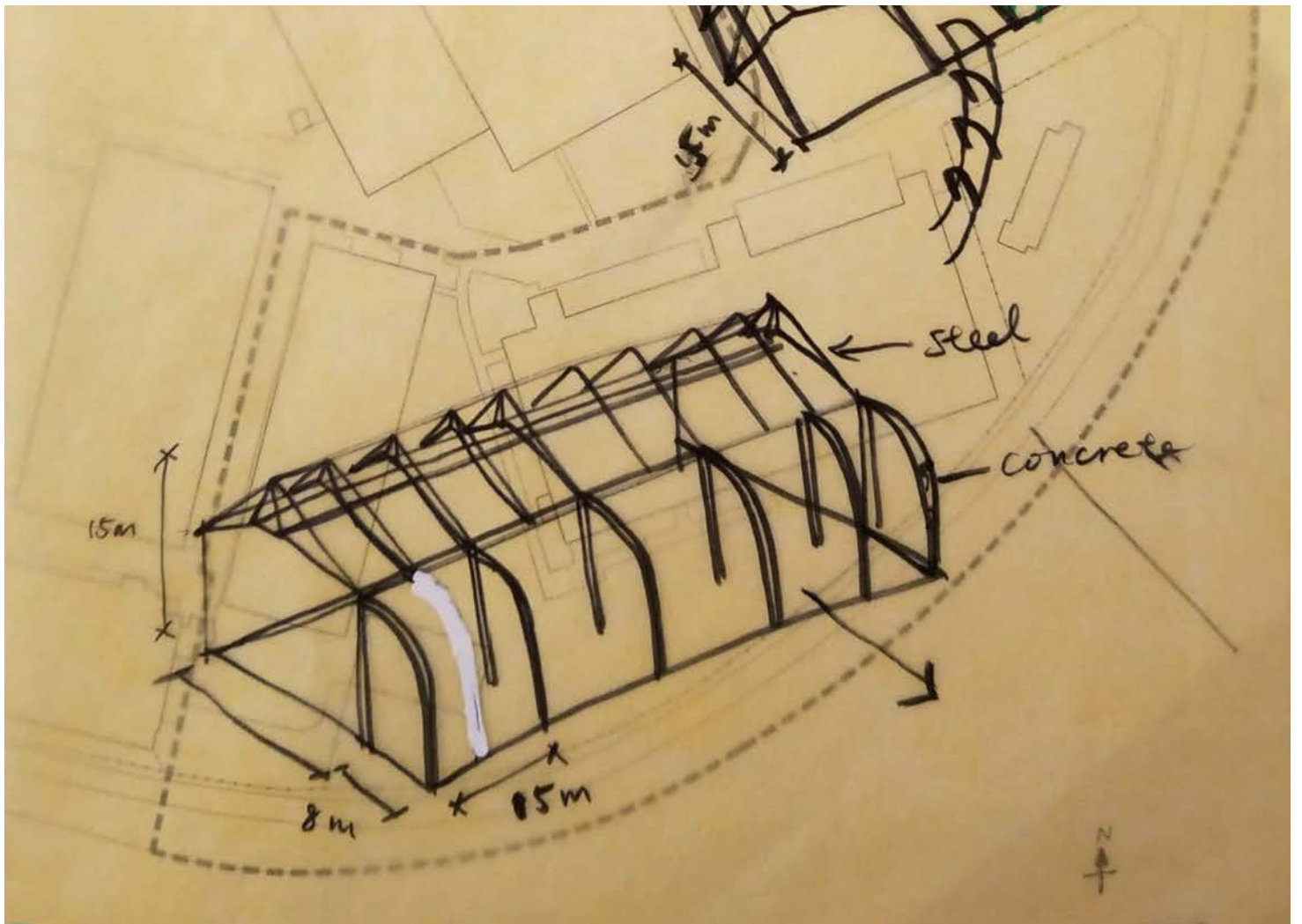

**Perspectives D:**

The black box theater is a composition of two structural systems (left page top sketch) that are very prominent in Hembrug. The first is a magnified version of the curved portal frame, signifying the end of the inner passage. The second half is the pitched roof with the polonceau truss system. I have selected the latter structural system for the main performance area because it accommodates for the height necessary of different theatrical programs and events.

On a further note, the curved portal frame will also be designed so that it can fully open to the water-front. This is consistent with the spatial quality of the other heritage buildings, so that in the case of a huge event or festival, the promenade can be fully activated on all ends.

*Left top:  
The theater is composed of two structural systems*

*Left bottom:  
Perspective D*

*Right bottom:  
Passage with sliding panel which can open up the theater to the outdoor space*

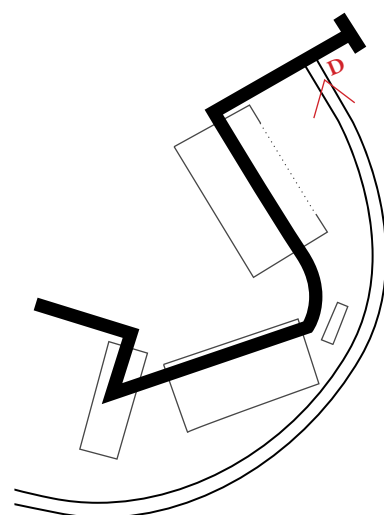
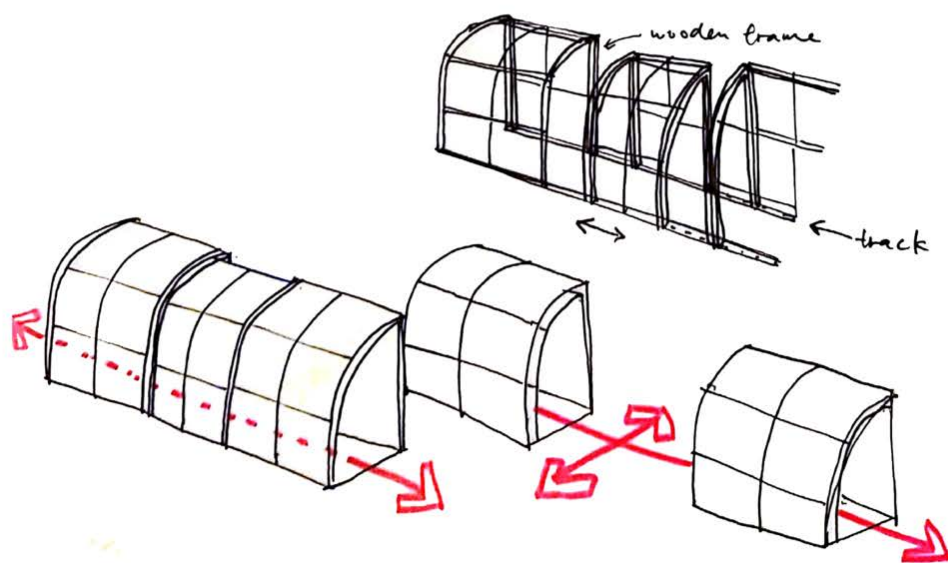



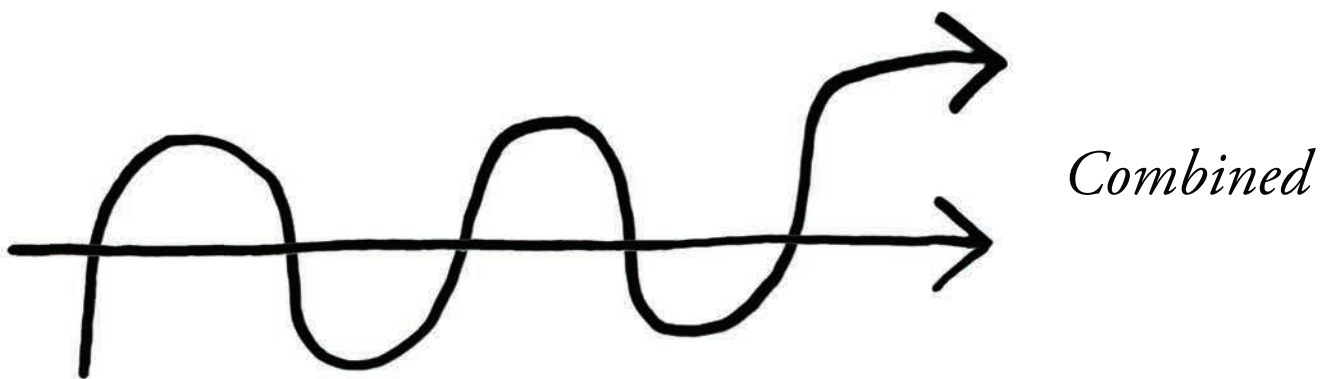
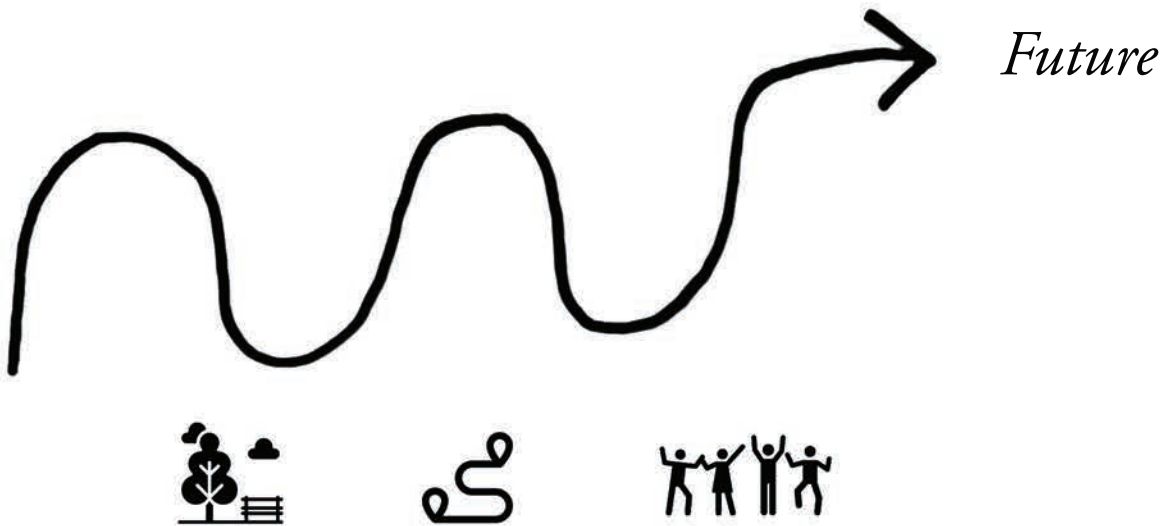

## THE PATHS

Upon discussion with tutors this week, we came to a conclusion that the passage made of the curved portal frames may create obstruction in the open space and limit movement of the visitors as it suggests only one designated browsing route. The routing can be suggested by programs or subtle changes of pavements, so that visitors can have options to wander around in the open area or visit the heritage buildings.

Thus, I extracted the essence of my initial idea - to create two paths in the Head of the Cape, one stands for the history while the other one represents the new intervention. I discovered that the historical path should be direct and straight forward as suggested by the spatial quality of the heritage buildings and their former functions. Take the ammunition factory as an example, the open plan layout and aligned door openings were designed to facilitate logistics and production flow back in the 1950s.

On the other hand, the proposed program aims to create a landmark for future events and activities and at the same time serves as a leisure park for social integration when there is no events happening. A meander path with pocket space can slow down people's pace and encourage interactions.

The project should bring these two movements together and create intersect points of the two paths.

*Sketch:*

*The two paths, one reflects the past and the other represents the future.*



*Greenery*



*Residential area*



*Restaurants*



*Warehouses*



*Cultural activities*



*Parking space*



*Retail*



*Office*



*Currently no function*



## CURRENT FUNCTION

When Hembrug was still active as an military industry, the terrain was separated in several zones with specific function. After the area became vacant, several squatters and artists came to Hembrug to start a creative subculture and gave new life to the old buildings. A diversity of functions started to emerge in Hembrug as shown in the map.

FUTURE FUNCTION DISTRIBUTION

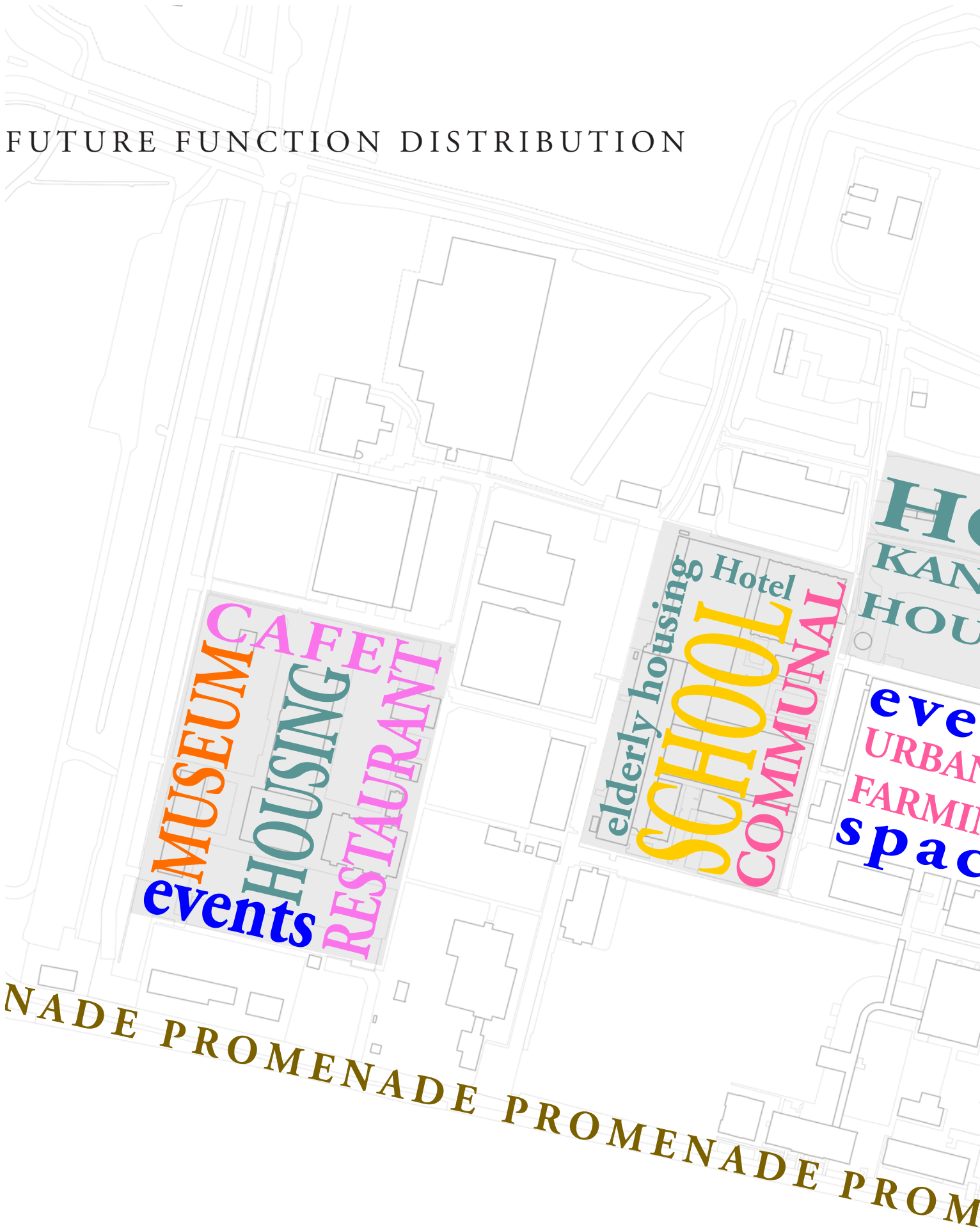







**MUSEUM**

**ARTILIER**

**WORKSHOP**

**ART STUDIOS**

**RESIDENTIAL**

**RECREATIONAL**

**PROMENADE**

**event space**

**EXHIBITION**



Inspired by Bo Bardi's project, I also tried to activate my site by programming. I intentionally put only the cultural and communal activities in the Head of the Cape (highlighted yellow ensemble shown on p.172-173) while most of my other fellow classmates try to incorporate housing in their design (grey ensembles). The rationale behind is that I want to shape the Head of the Cape as a place for all where the public can fully engage in the communal activities without accidentally walking into someone's backyard. Together with the museum and artiller nearby, they form a cultural belt at the fringe of the Hembrug terrain. However, I did not turn my back on the residential needs. I also incorporated housing units right behind my site.

Given that OMA is going to create an event space connected to its cultural center while some of my classmates proposed it to be a museum. Either way, it will bring a lot of visitors to the Head of the Cape. Therefore, I turn the outdoor space into a recreational park where visitors can walk freely to discover more art and cultural related activities housed in the heritage. For instance the projectile workshop will be transformed into art studios for handcrafts, the rear corridor of the ammunition factory will turn into an exhibition space which is linked to the restaurant that opens up to the waterfront. A black box theatre will be added in the northern part where it is currently an empty plot. The ground level can be fully open up and serve as an event space to hold festivals or large scale events.



# THE PATH - PAST



 Existing "dead" streets







*Activated existing entrances*



*New entrances*







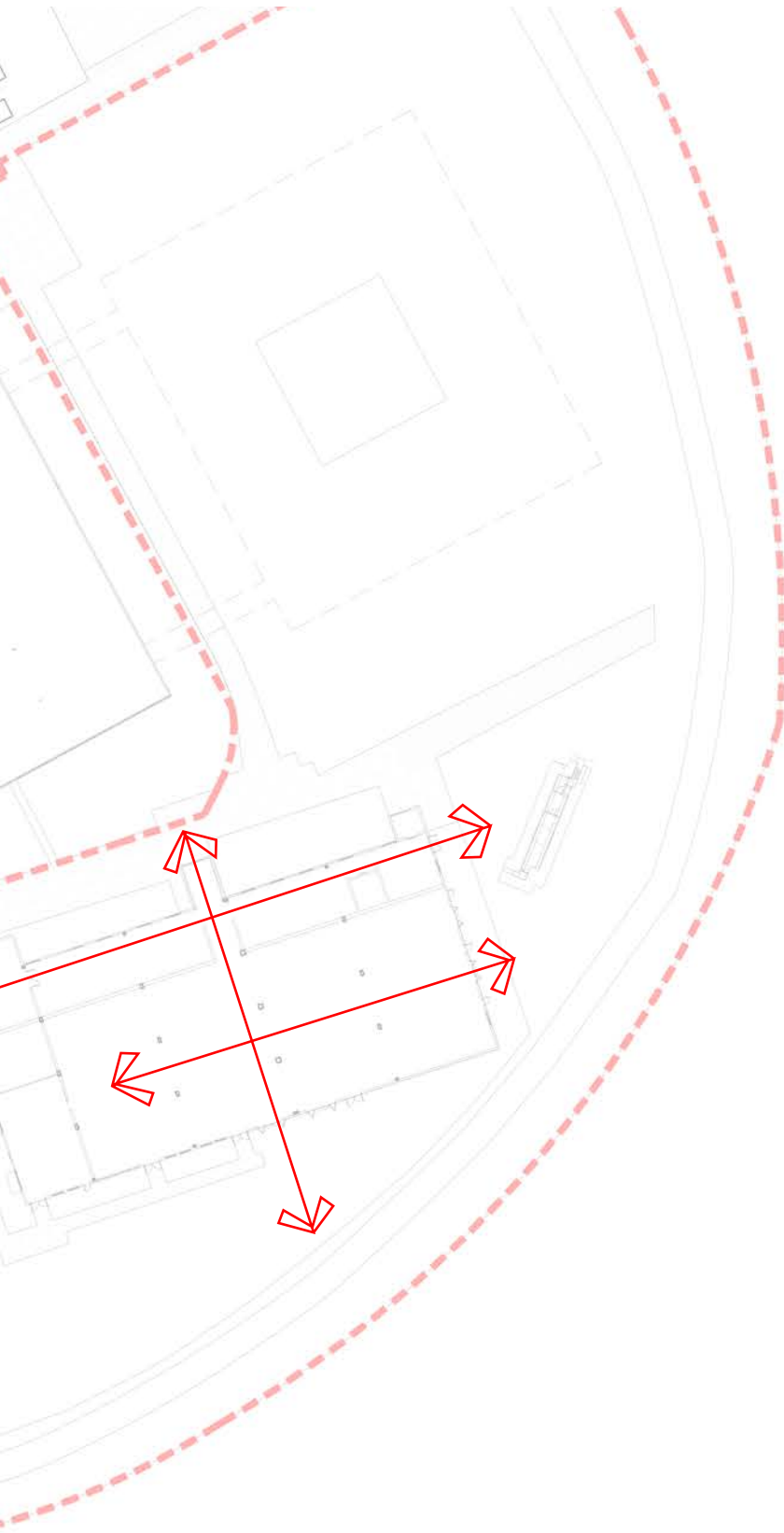

Starting from the end of the Middenweg, the streets are “dead” since there is no reason for visitors to continue their exploration into the Head of the Cape (p. 176-177). So, I want to activate these dead streets by introducing new programs.

I connected the streets with some of the existing openings in the buildings and I also created some new openings (p.178-179). Together, they lead people from the outdoor space to the interior with lots of dynamic activities. I have kept in mind that all the intervention should always maintain the fluidity of the plan, both physically and visually. The new partitions in the projectile factory create two corridors on the sides without any obstruction. The visual connection is regained in the projectile factory by the use of low lying partition walls just like how Bo Bardi did in the Pompeia factory.

For the ammunition factory, the aligned door openings and open plan are kept to maintain the two directional fluid circulations.

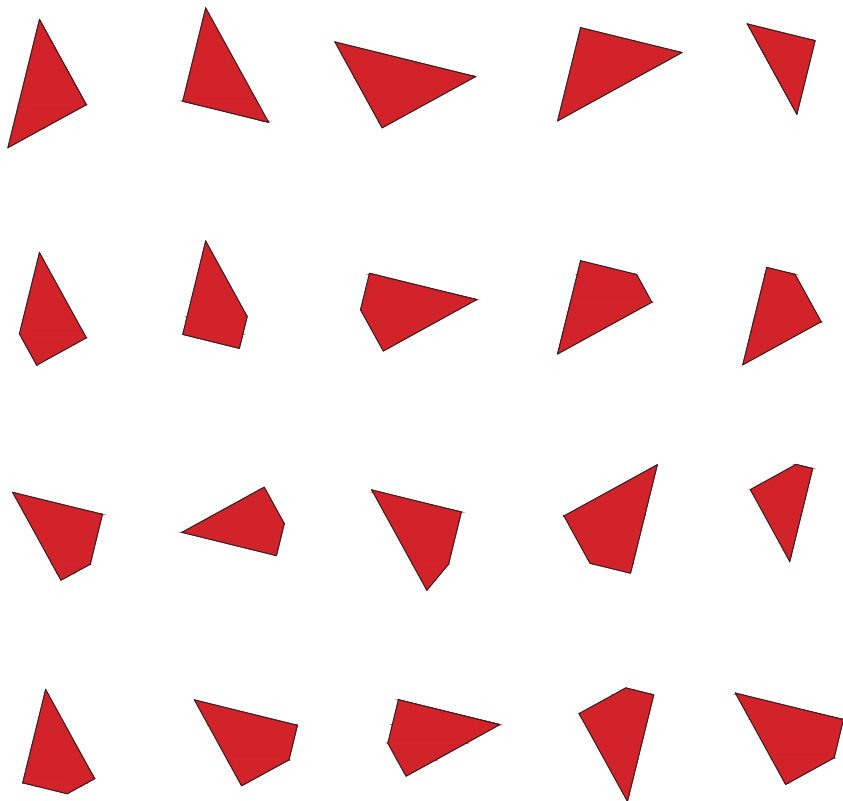
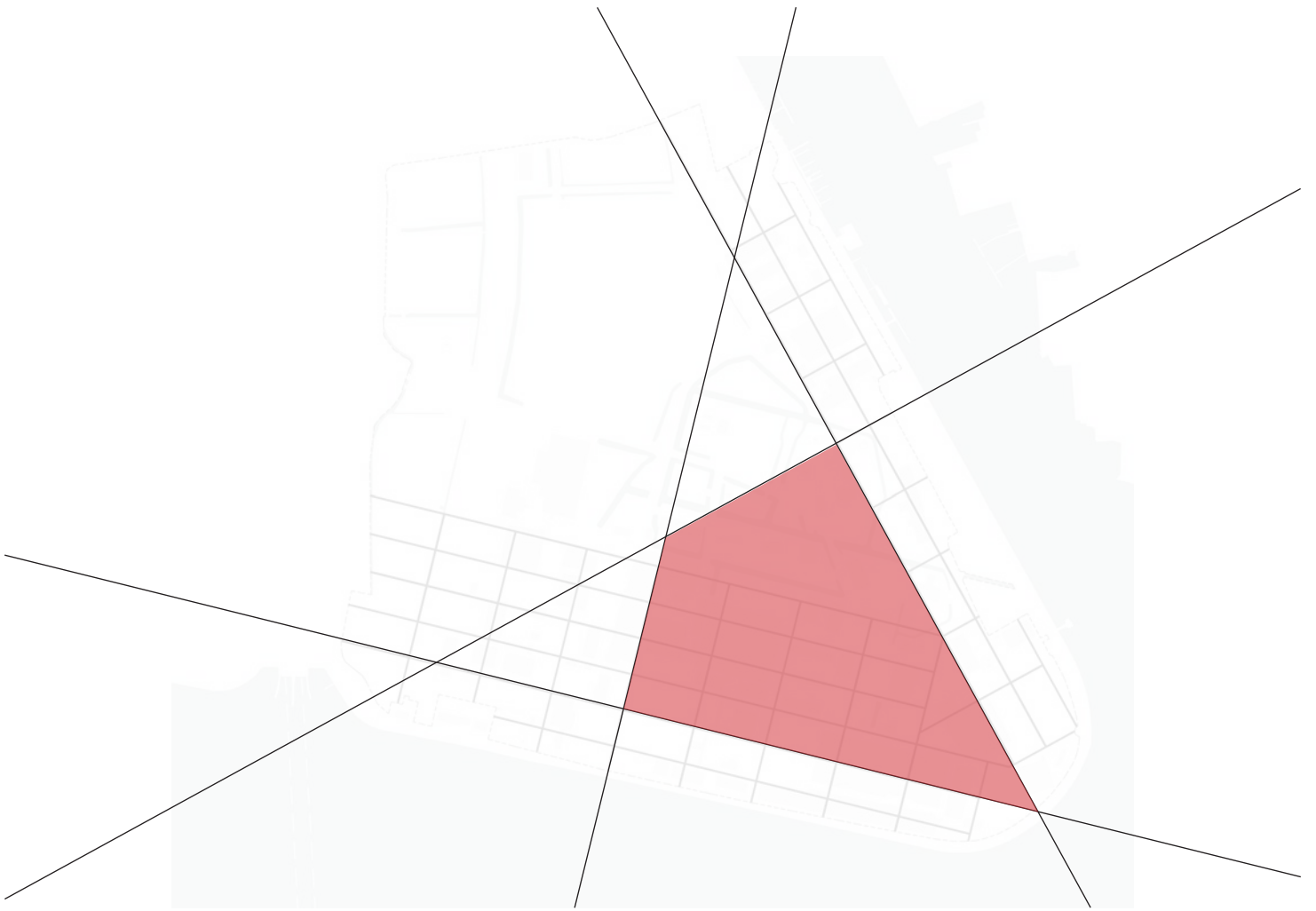



## THE PATH - FUTURE

As for the path for future, which should promote people gathering and stimulate them to interact and share ideas, the path becomes more meander to slow down people's movement. But what shapes the movement of people? How can architecture inform people how to move around in a space? Therefore, I looked back in my analysis and discovered that people move along the grids derived by the layout of building blocks and road pavement.

Just like Bernard Tschumi suggested in his theoretical project, Manhattan Transcripts<sup>1</sup>, people movement, objects and events are three interlinked components. The transcripts dissected reality into simple elements. The essence of the transcripts does not lie in the accurate translation of the outside world, but in the internal logic these sequences display. Thus, I tried to find the internal logic to deal with the off grid situation in the Head of the Cape. I extracted the most prominent grid lines from the two grid systems in Hembrug and tried to incorporate them as one.

By superimposing the four major grid lines, interesting spaces start to emerge. Some variations generated from the combination of three to four grids are shown on the left.

*Top:*

*Four major grids extracted from the two grid systems in Hembrug*

*Bottom:*

*Variations of space generated from the combination of three to four grids*

*Source:*

*1. Tschumi, Bernard. 1994. The Manhattan Transcripts : Theoretical Projects. New York: St. Martin's Press, p. 16-23.*

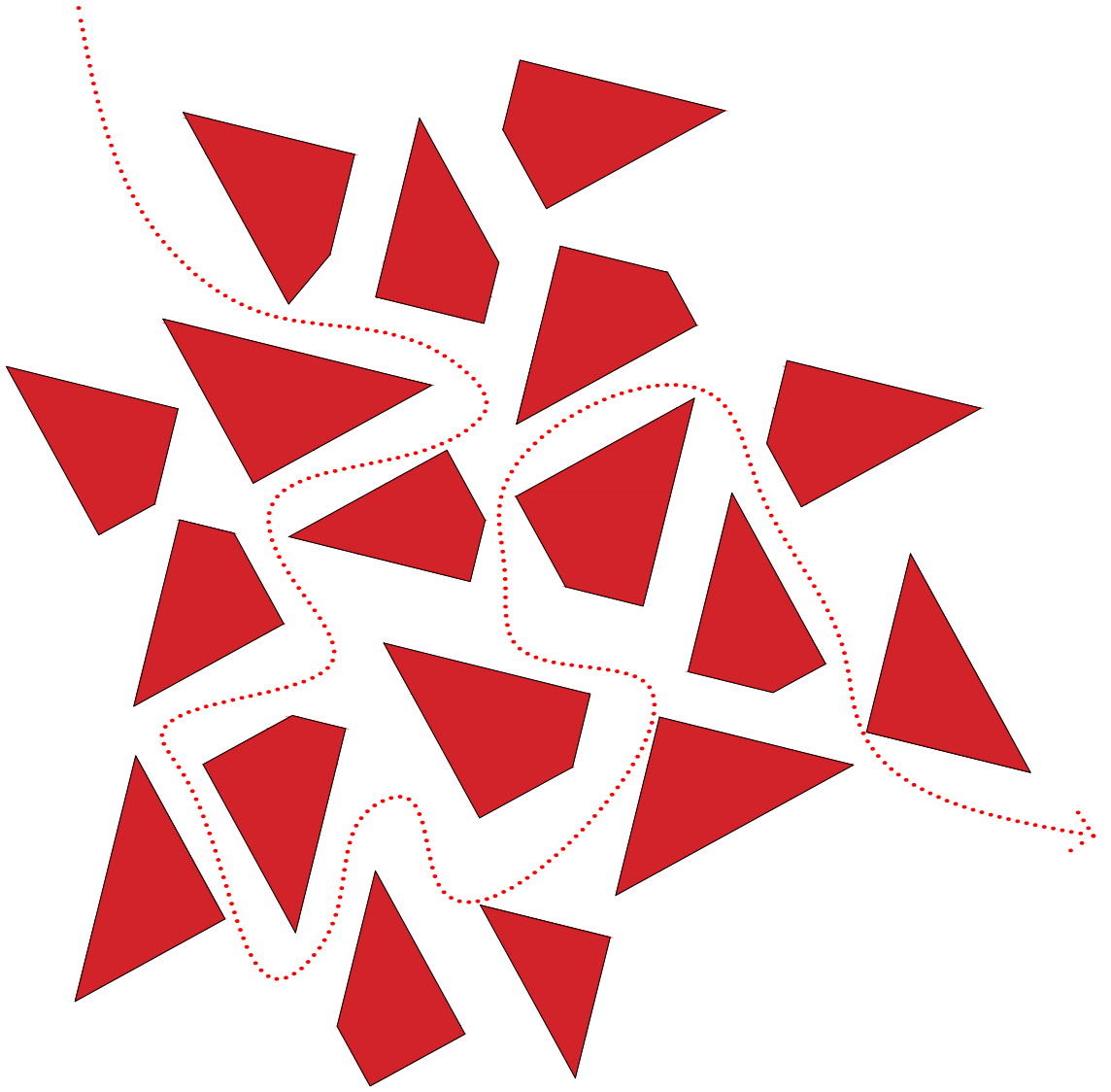

By juxtaposing these spaces together, a meander path manifests itself among the interstitial space. The space becomes places for people to stay, gather or rest along the meander path. The appropriation of space is done by putting small interventions, for example, tables and chairs, plants, benches and wooden deck. The outdoor space can be truly activated and enjoyed by the public instead of being just a mere lawn.

*Left:  
A meander path defined by the  
interstitial space between the patches*



# PROPOSED MASTER PLAN





# HERITAGE POSITION

NON-INTENTIONAL  
COMMEMORATIVE

VALUE

USE VALUE



STRUCTURE /  
SKIN



Preservation

Repair

Infill

Int



RELATIVE  
ART VALUE

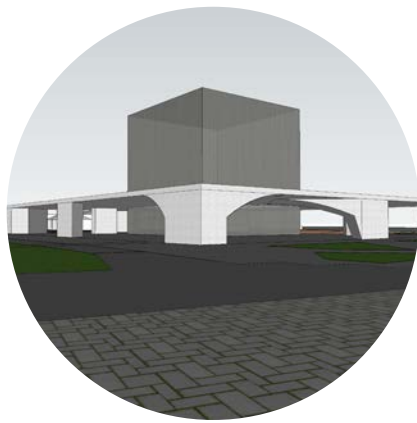

Intervention

Transformation /  
Reinterpretation

There is a wide spectrum of how to deal with heritage, ranging from preservation to a complete transformation or reinterpretation of the old buildings.

This is how I position myself within these approaches for each of the existing buildings. The commander bunker will be repaired and preserved since it is a national monument. The ammunition factory will mainly have new infill and a few interventions to cater the program and to improve the comfort of use. The typology and the skylights will be kept since I valued them high in the previous cultural value assessment. Moving on to the projectile workshop, it will have major interventions for the interior and part of the facades. Similar to the ammunition factory, the structure and skylights in the projectile workshop will be kept in the interventions. Finally, the black box theatre is my reinterpretation of the essence of Hembrug.

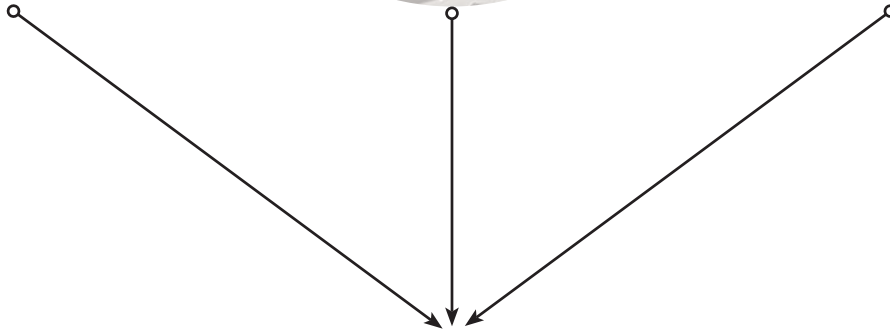
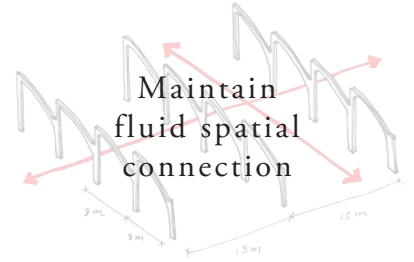
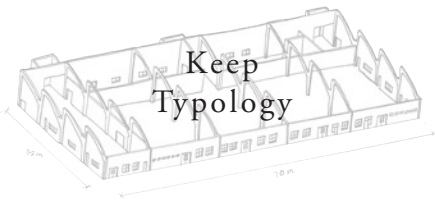

Spatial Design

# TRANSFORMATION PRINCIPLES

During all the interventions, I held three principles derived from the previous site analysis - the typology, the materiality and the spatial quality.

The previous typological study shows that the historical spirit of Hembrug lies in the special typologies, the original materials and the fluid spatial connections in various factories. The three principles that I hold when dealing with the transformation are:

1. To keep the building typology;
2. To preserve the original material as much as possible and
3. To maintain the fluid spatial connection.



# PROJECTILE WORKSHOP TRANSFORMATION

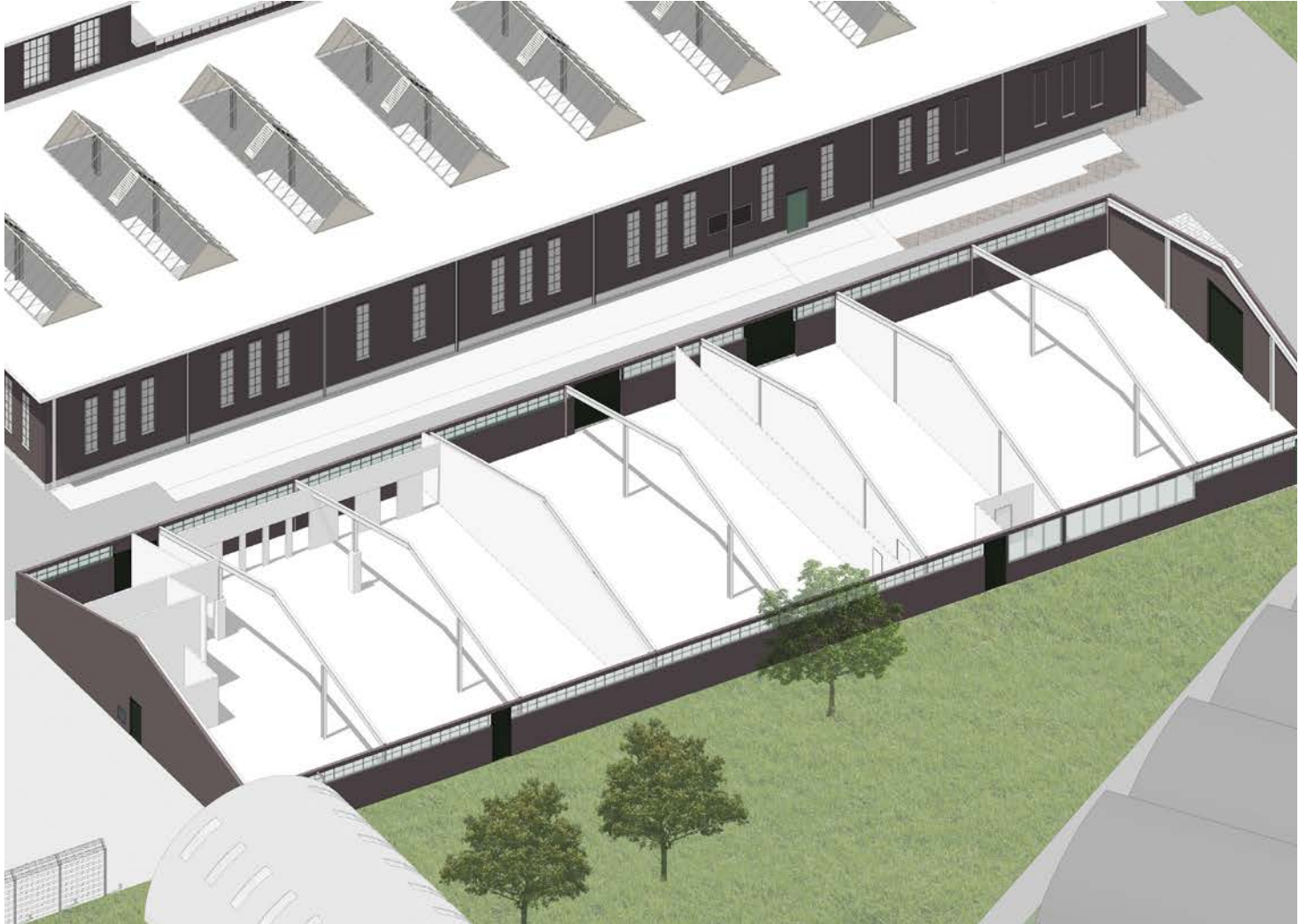

*Before*

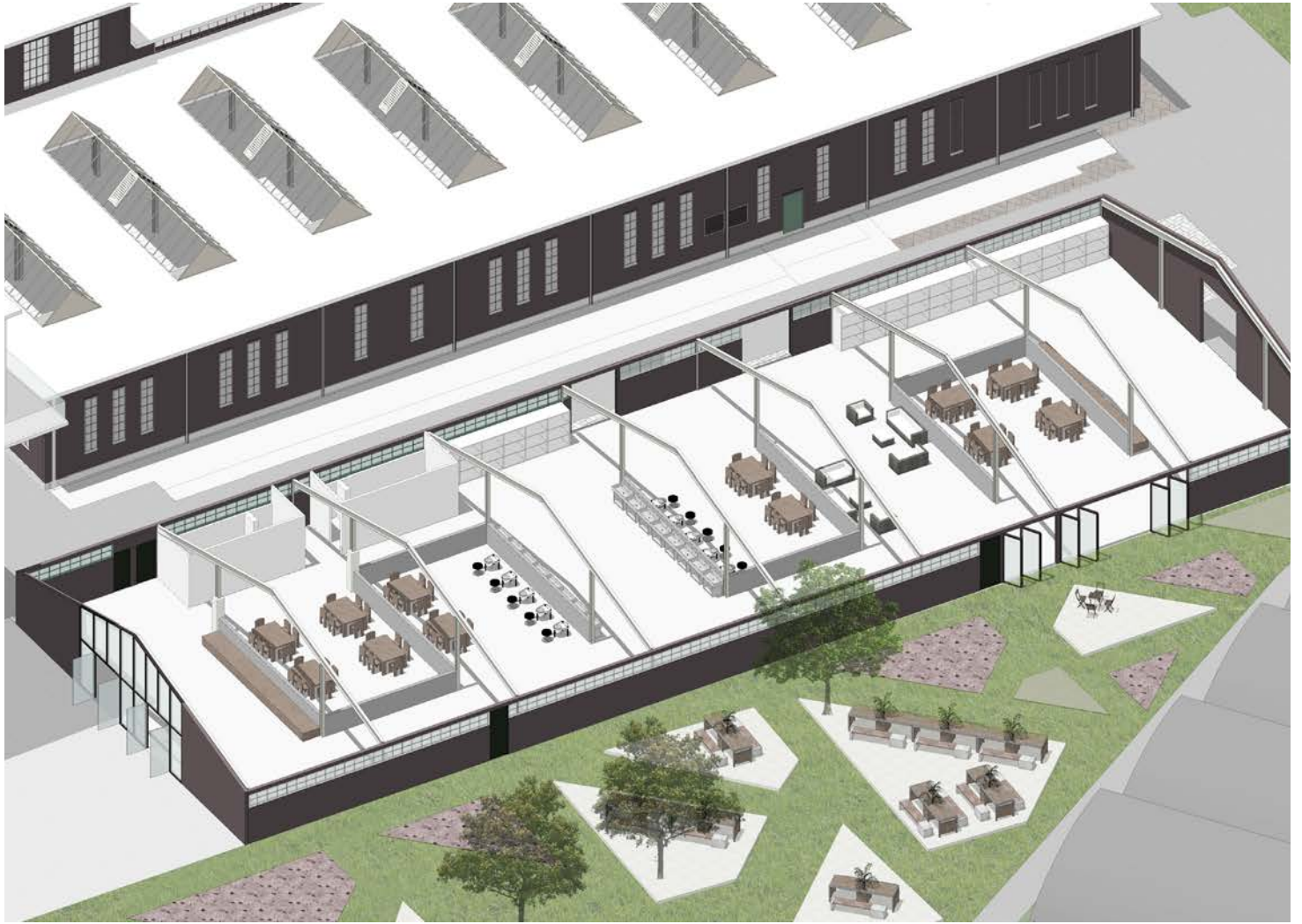

*After*

Existing floor area  $m^2$

Storage space	1054.5
Toilet	<u>51.84</u>
Total	1106.34

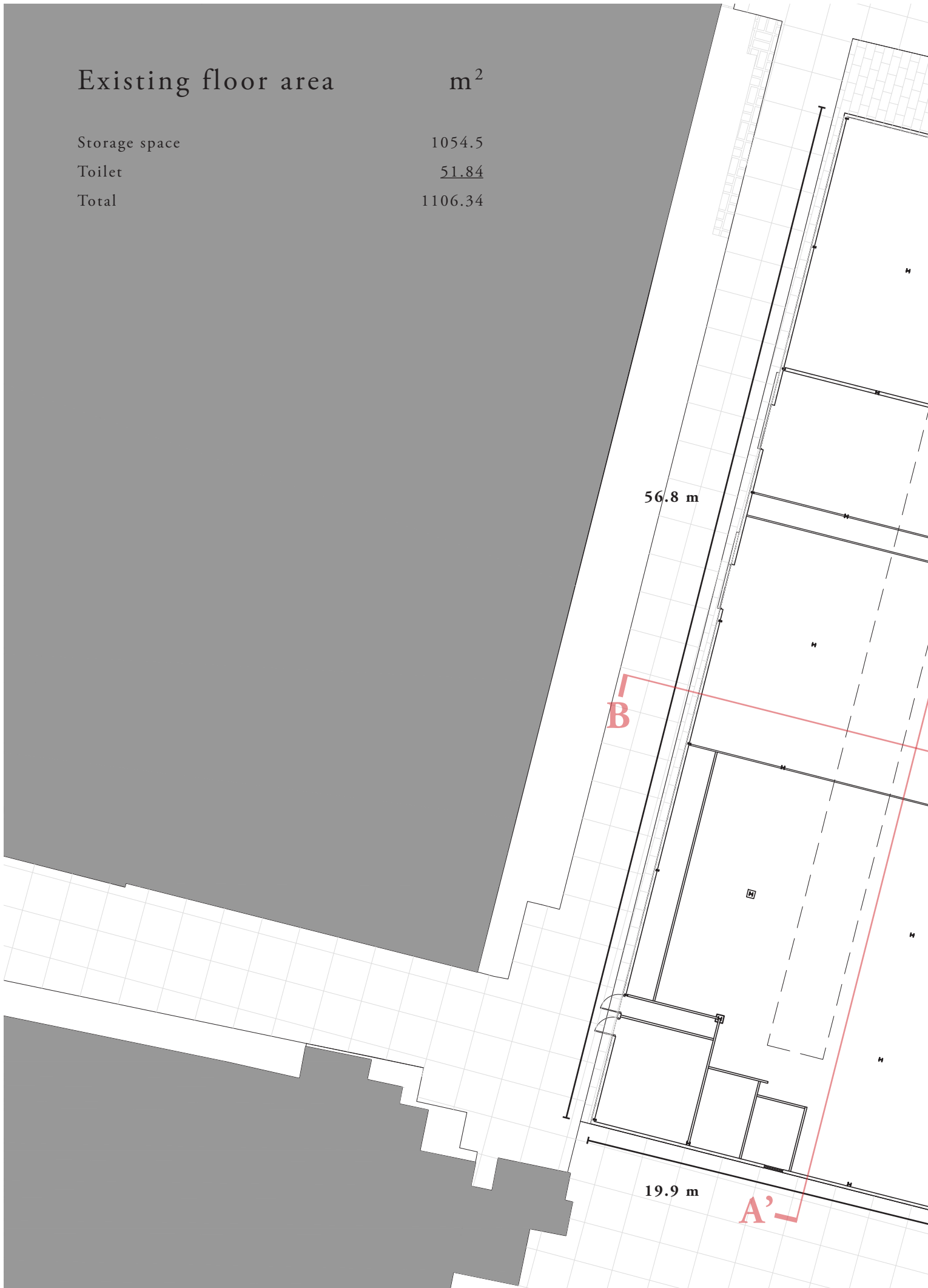



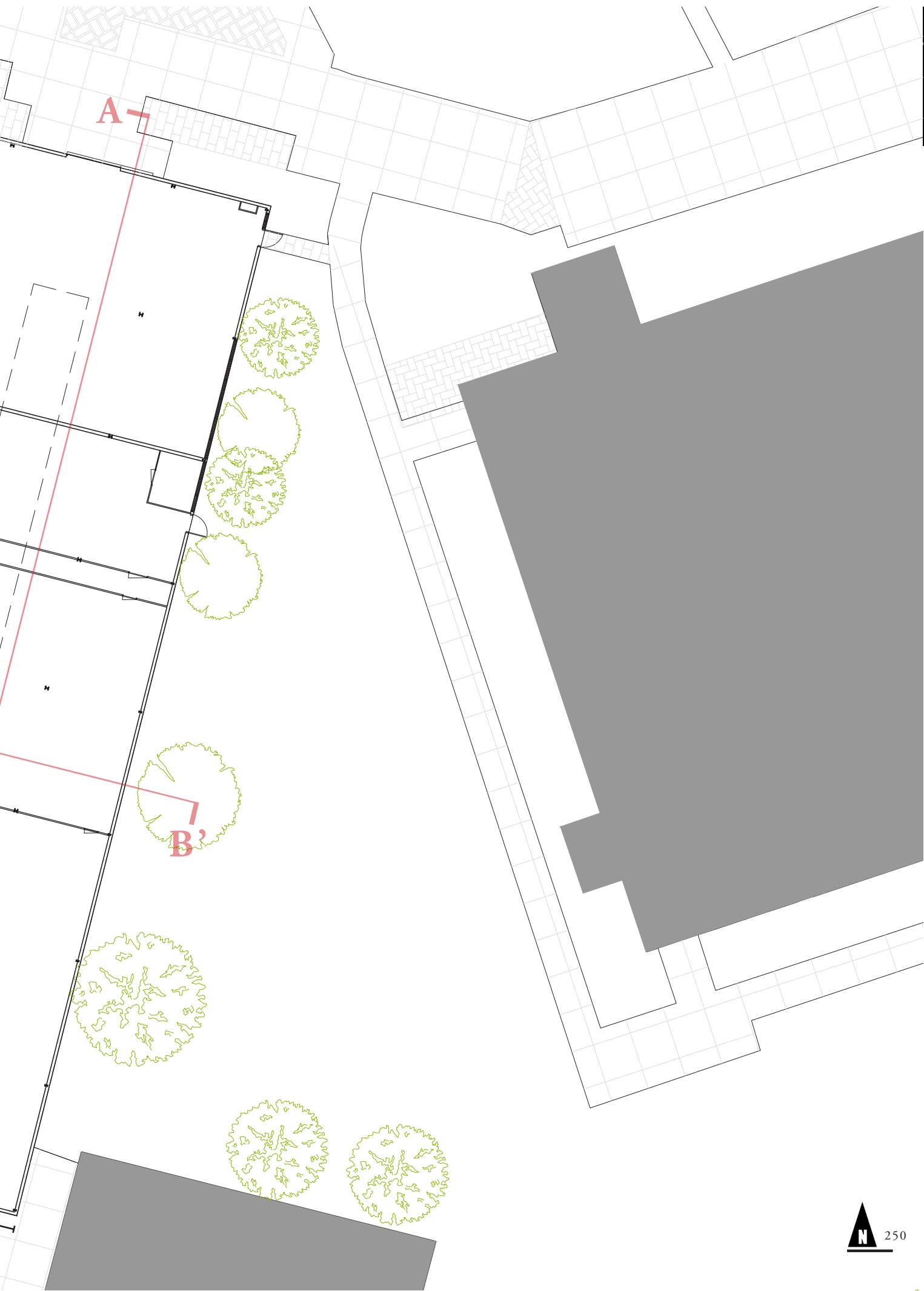

# Proposed floor area $m^2$

Art Studios	244.15
Communal area	119.85
Toilet	29.76
Circulation and storage	<u>712.58</u>
Total	1106.34

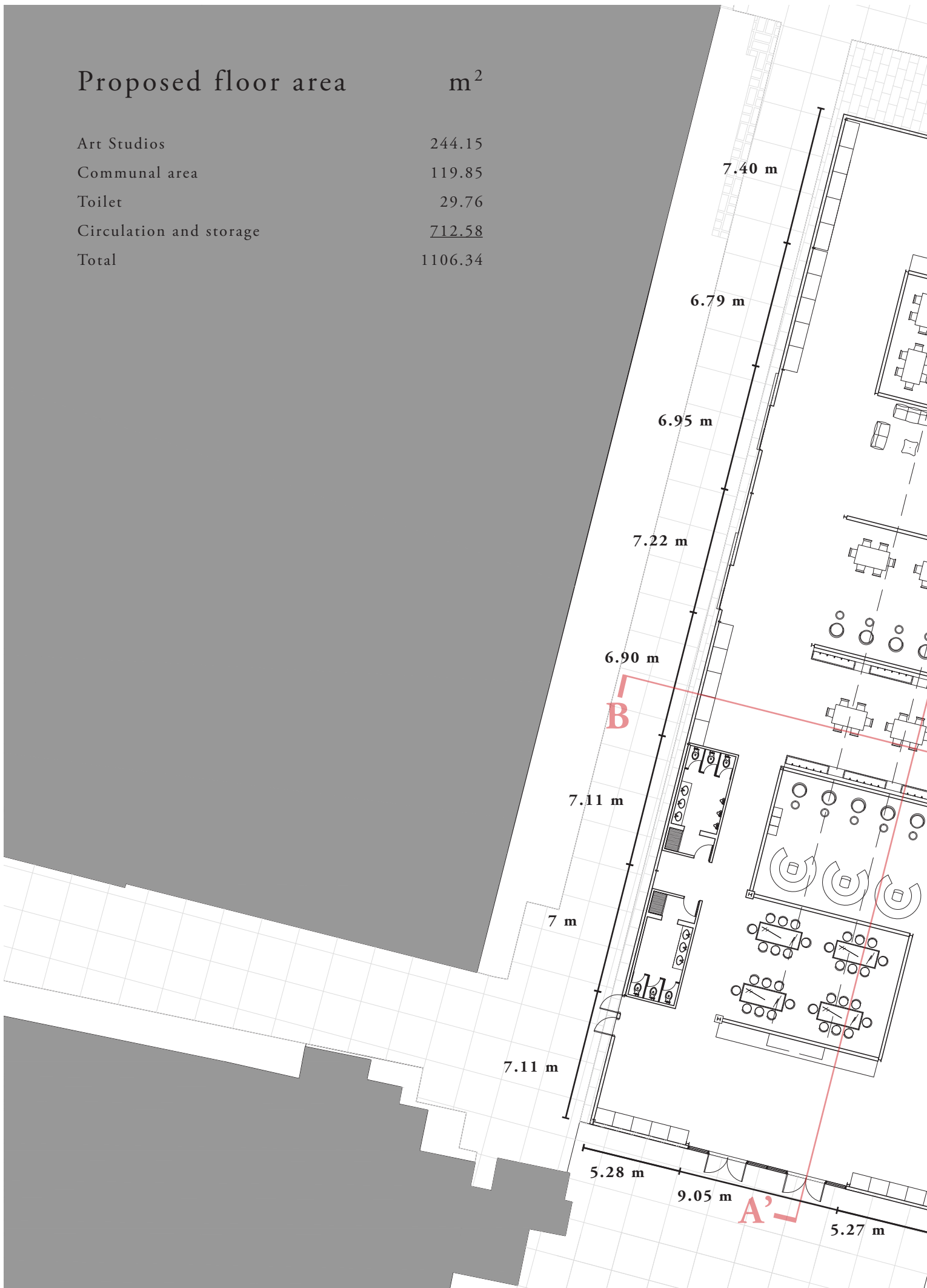





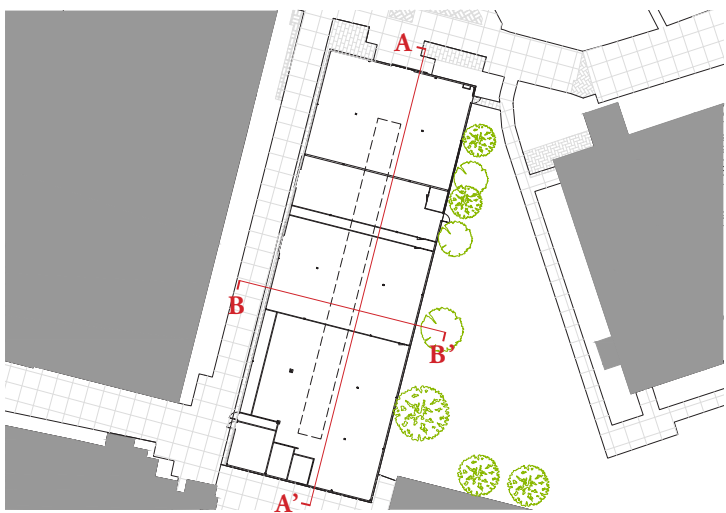



Above:  
Existing Section A-A' of projectile workshop



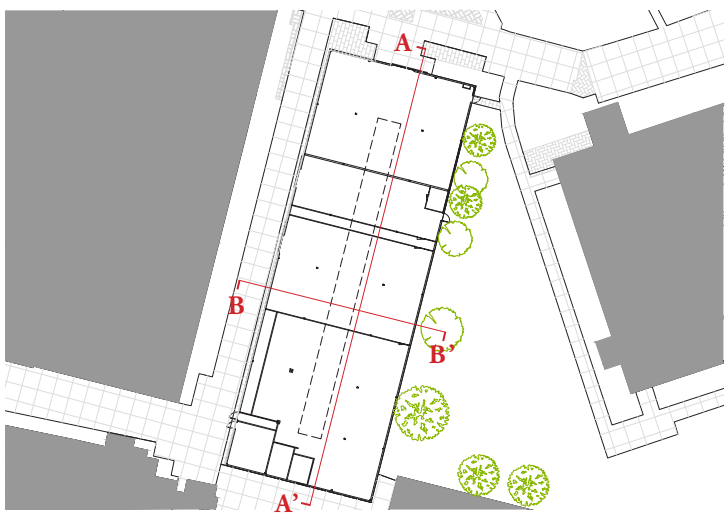





Above:  
Proposed Section A-A' of projectile workshop



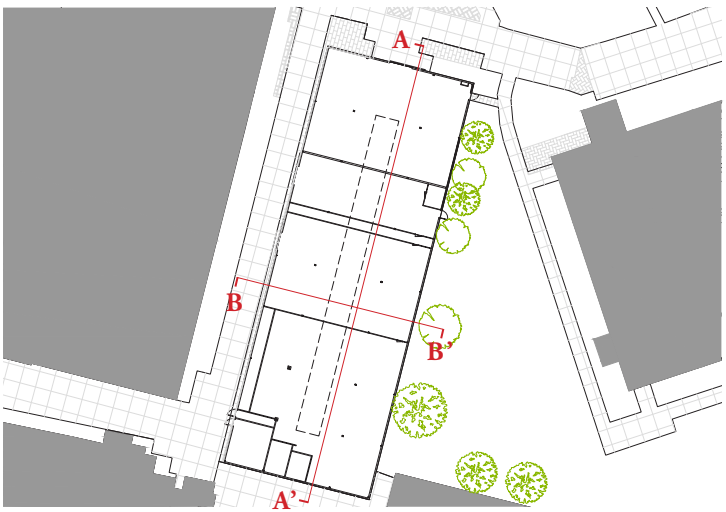



Above:  
Existing Section B-B' of projectile workshop





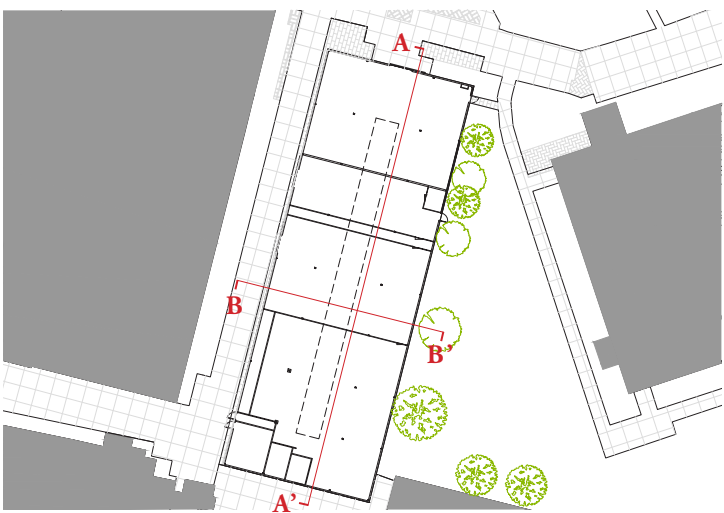



Above:  
Proposed Section B-B' of projectile workshop



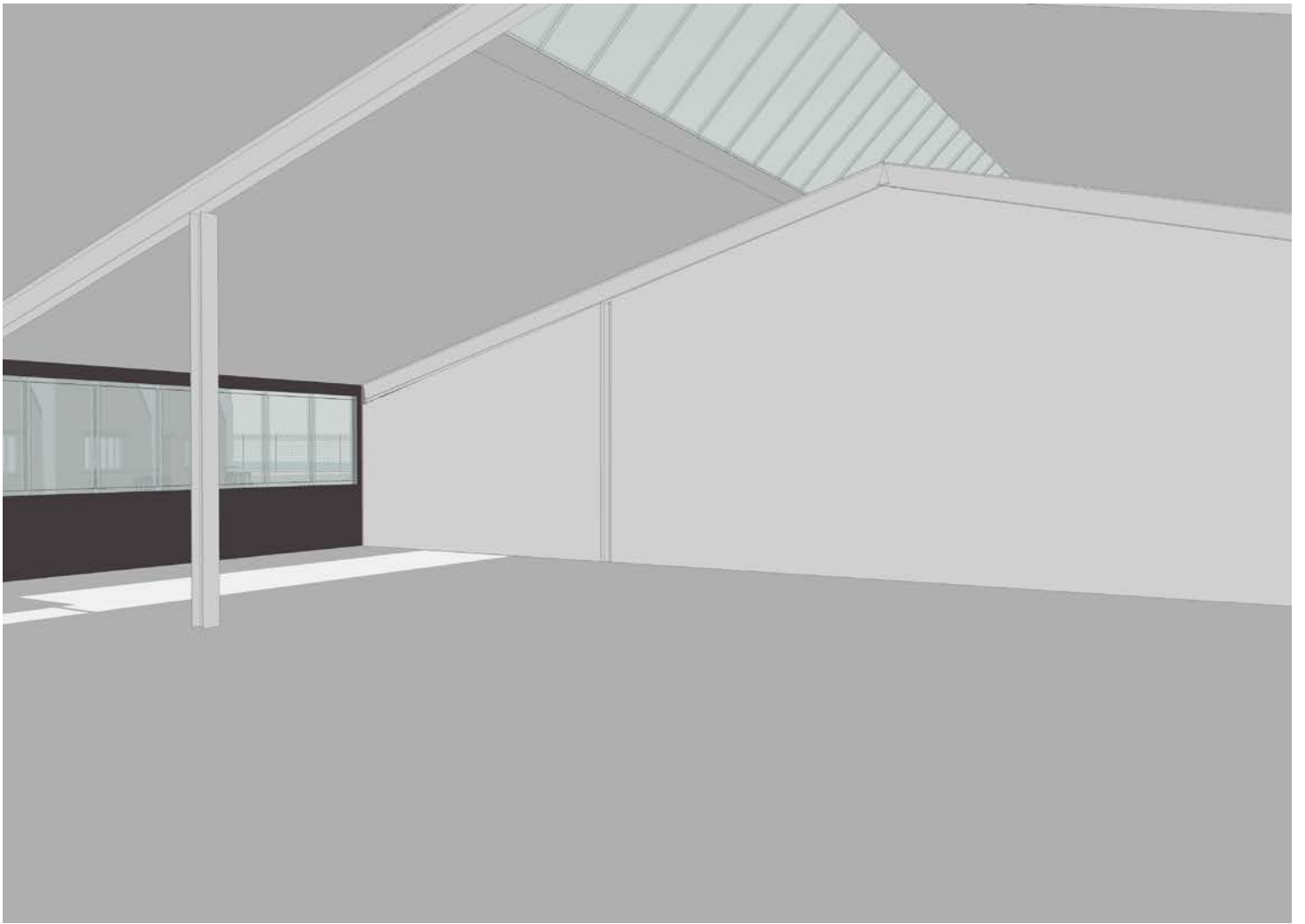

*Before*

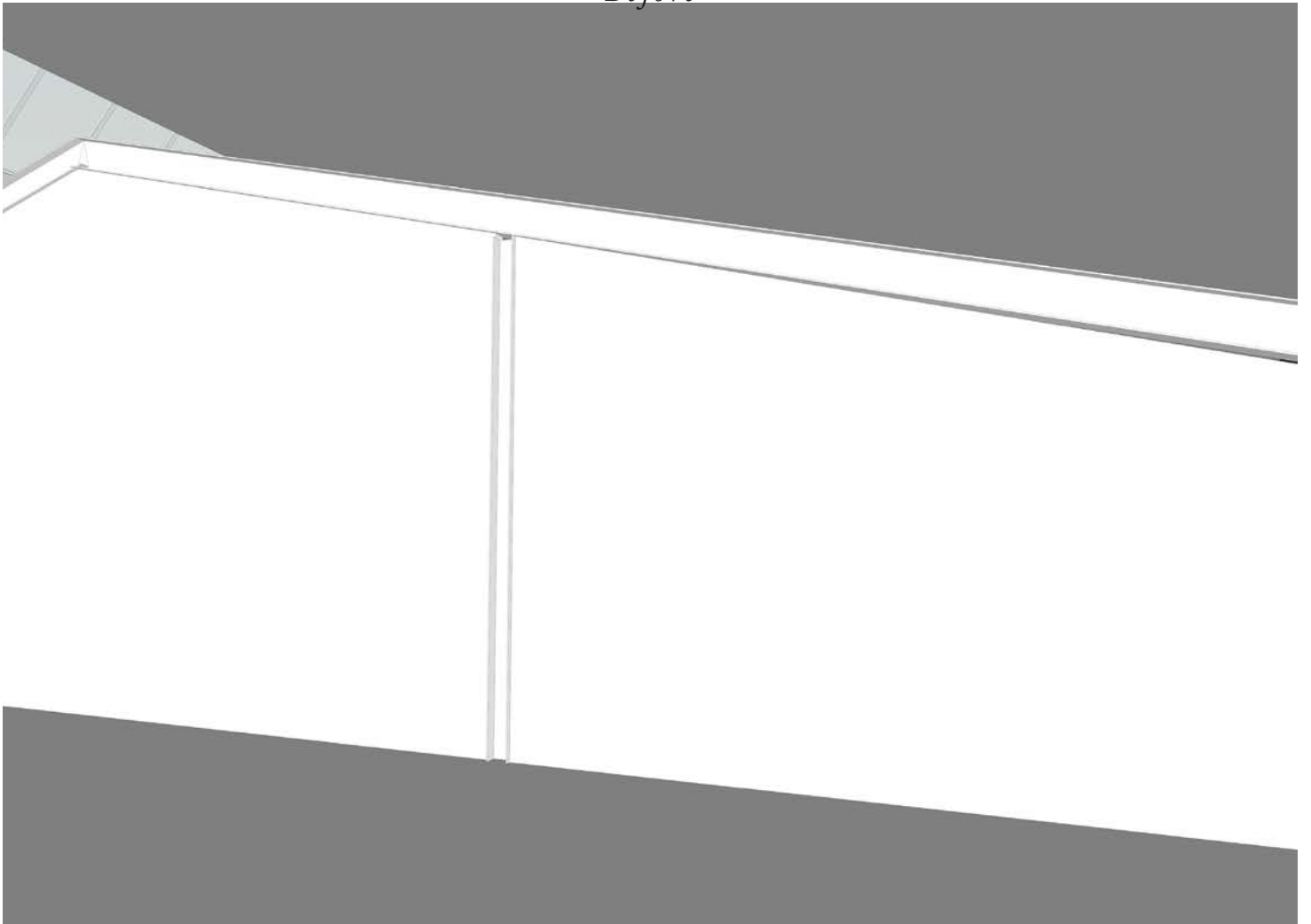





*After*

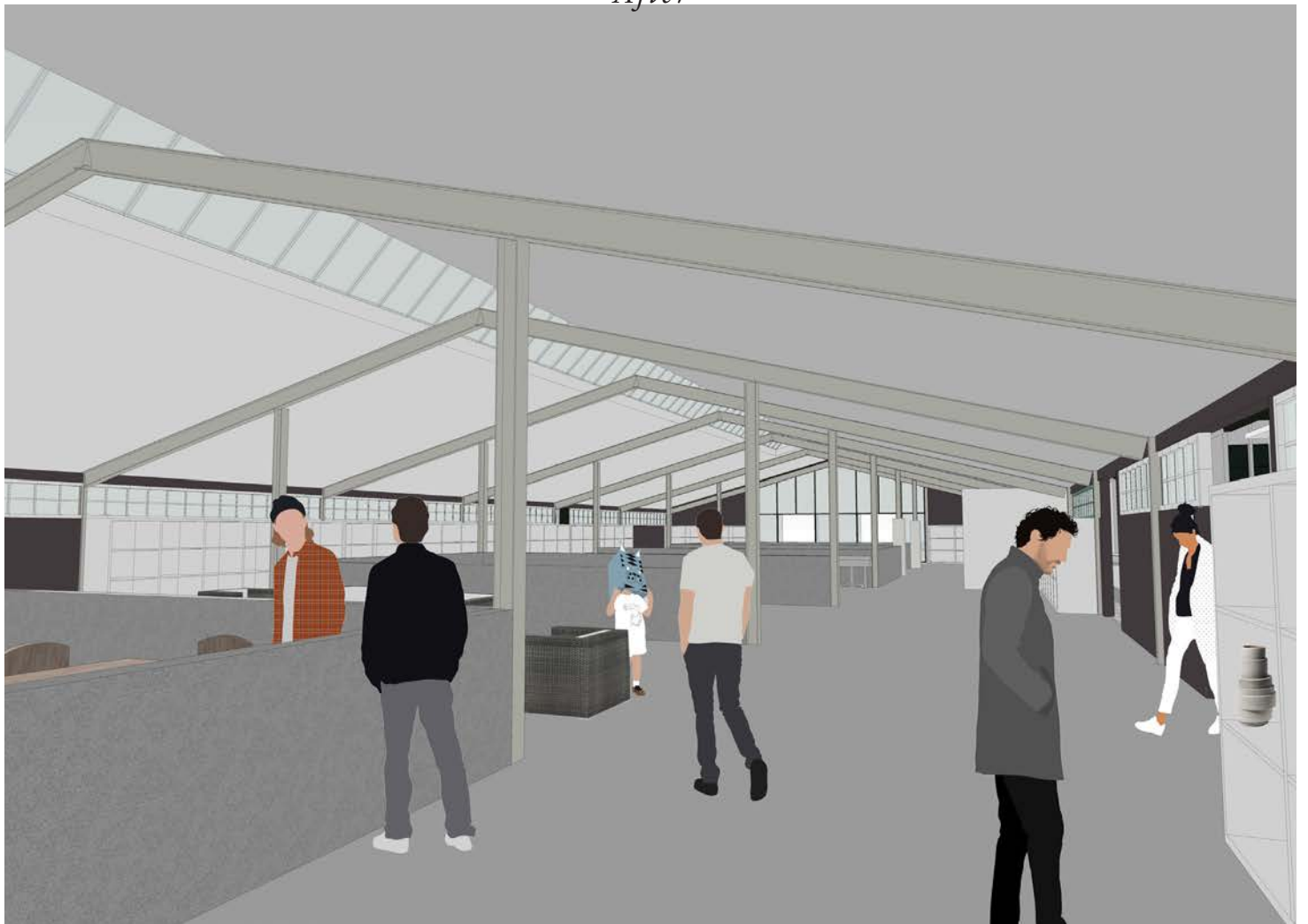



*Before*







*After*







*Before*



*After*

# AMMUNITION FACTORY TRANSFORMATION



*Before*





*After*

# Existing floor area $m^2$

Storage space	2214.47
Toilet	28.62
Office	<u>61.21</u>
Total	2304.30







# Proposed floor area $m^2$

Exhibition space	522.45
Restaurant and Bar	675.59
Kitchen	28.62
Communal area	698.97
Internal street	305.4
Storage space	23.77
Toilet	49.50
Total	2304.30
Additional floor area	
Reading area	388.19
Total (+16.85%)	2692.49

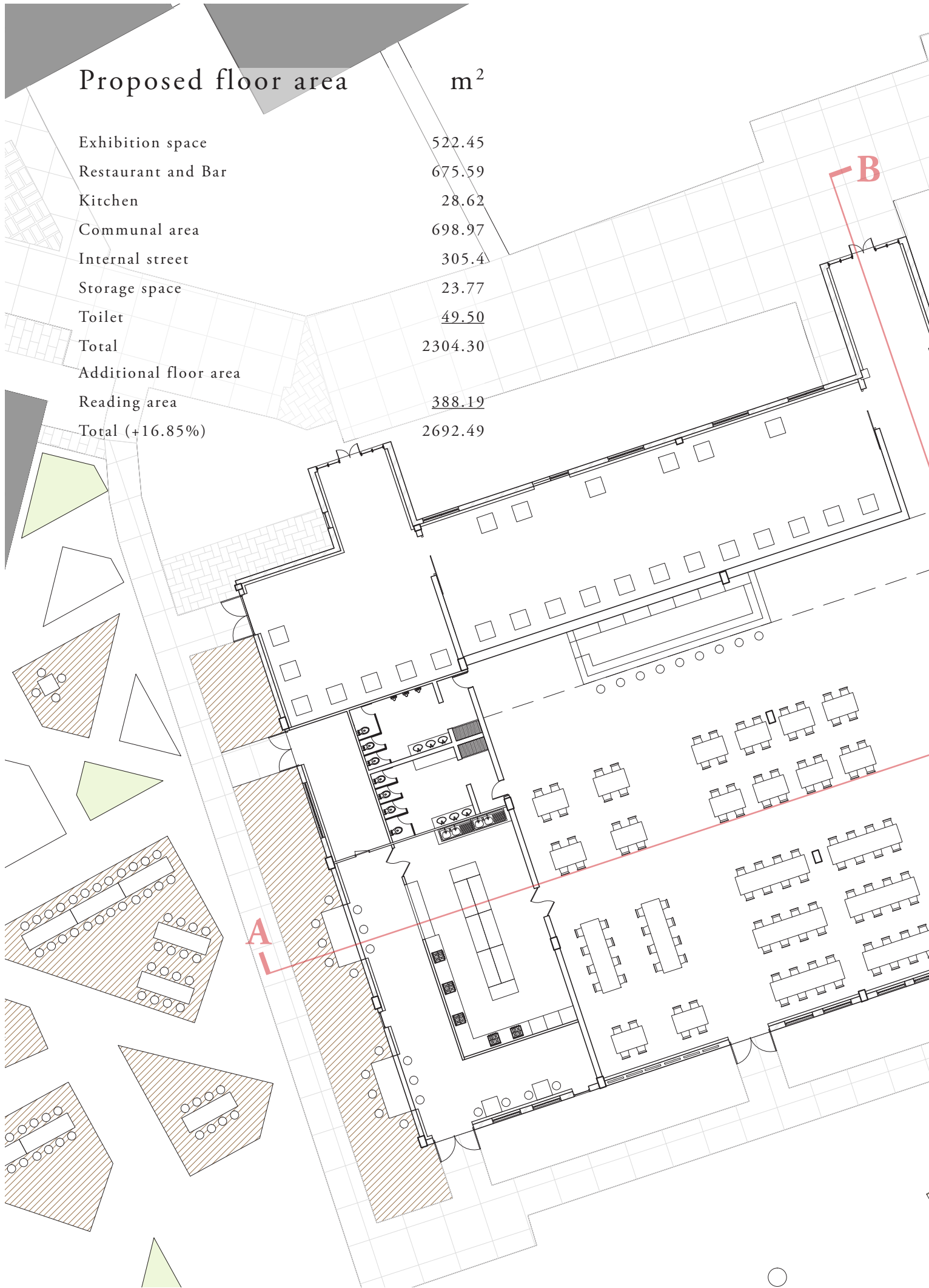

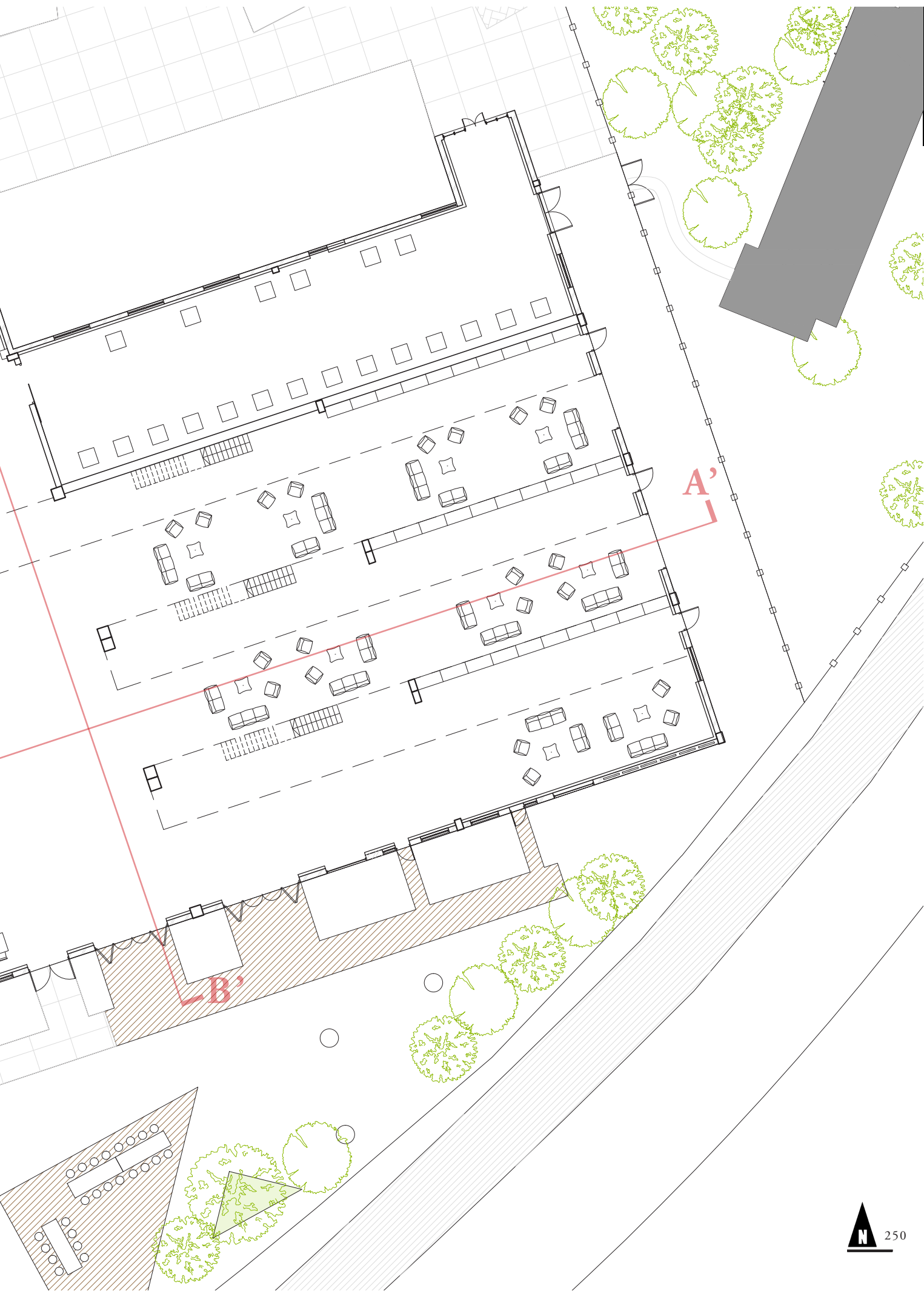

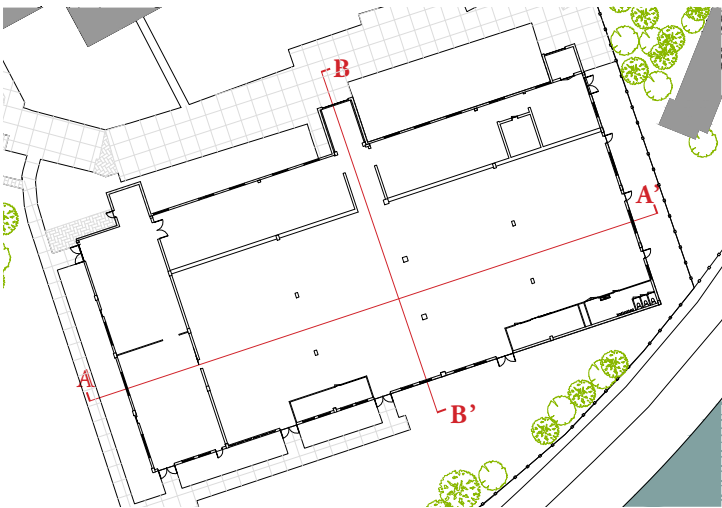
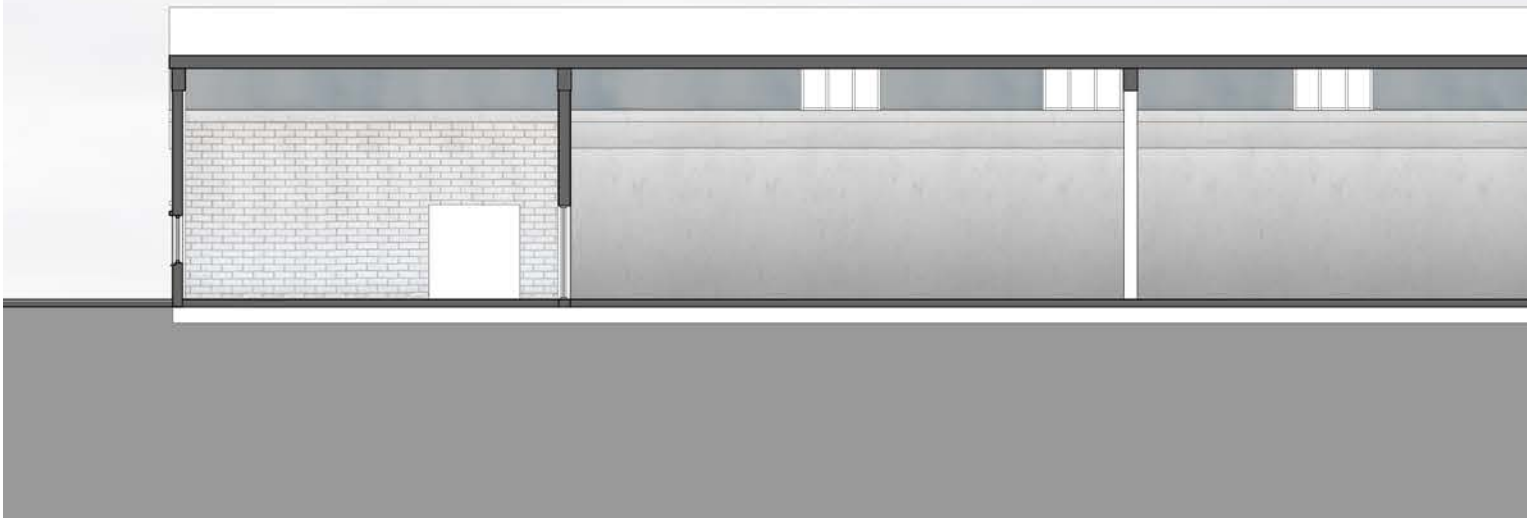





Above:  
Existing Section A-A' of ammunition factory



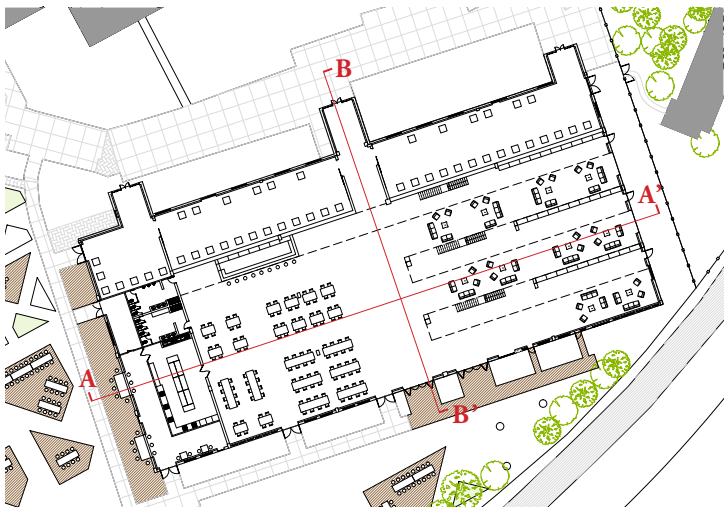
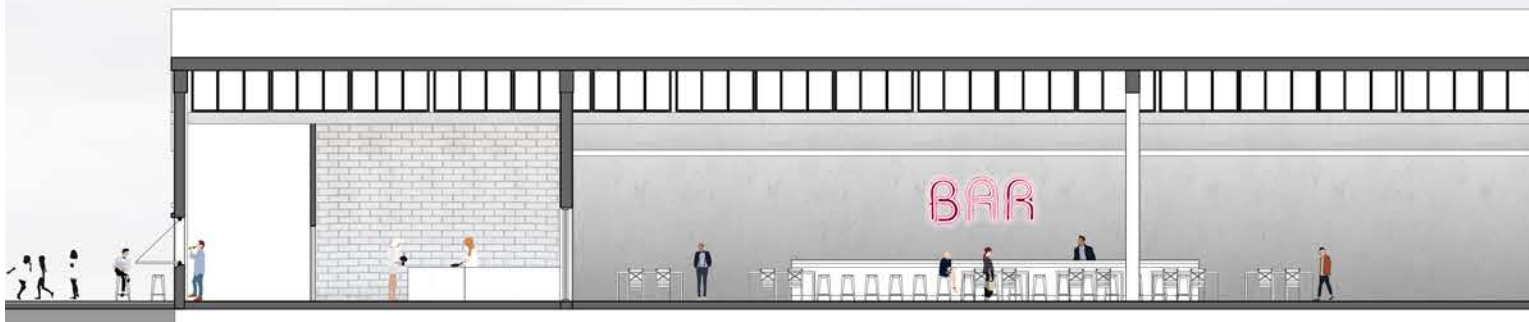



*Section A-A'*

Above:  
Proposed Section A-A' of ammunition factory





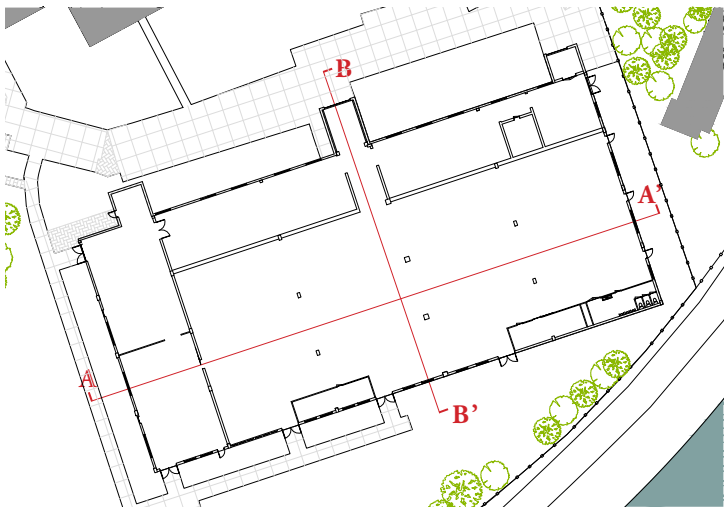
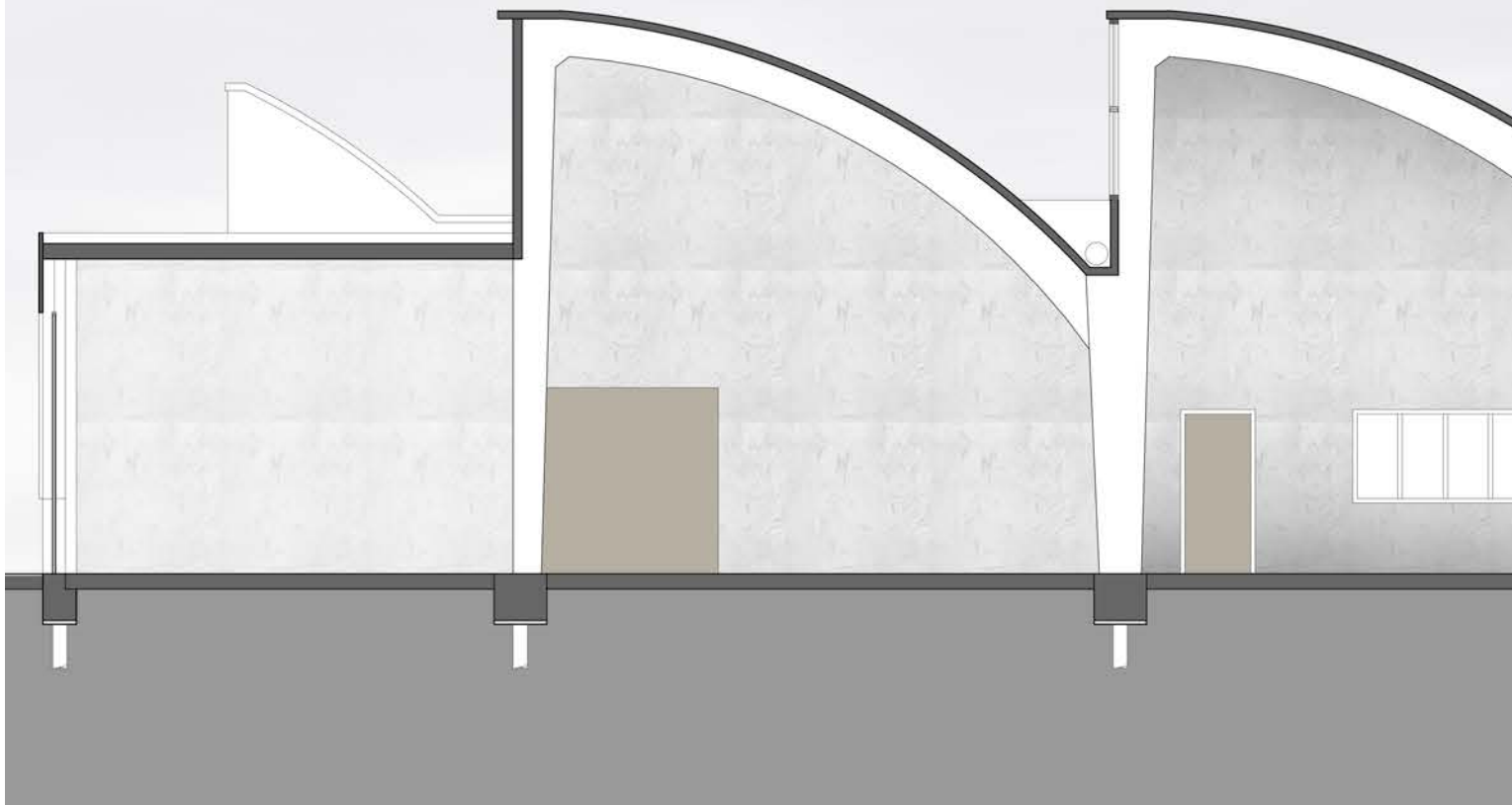

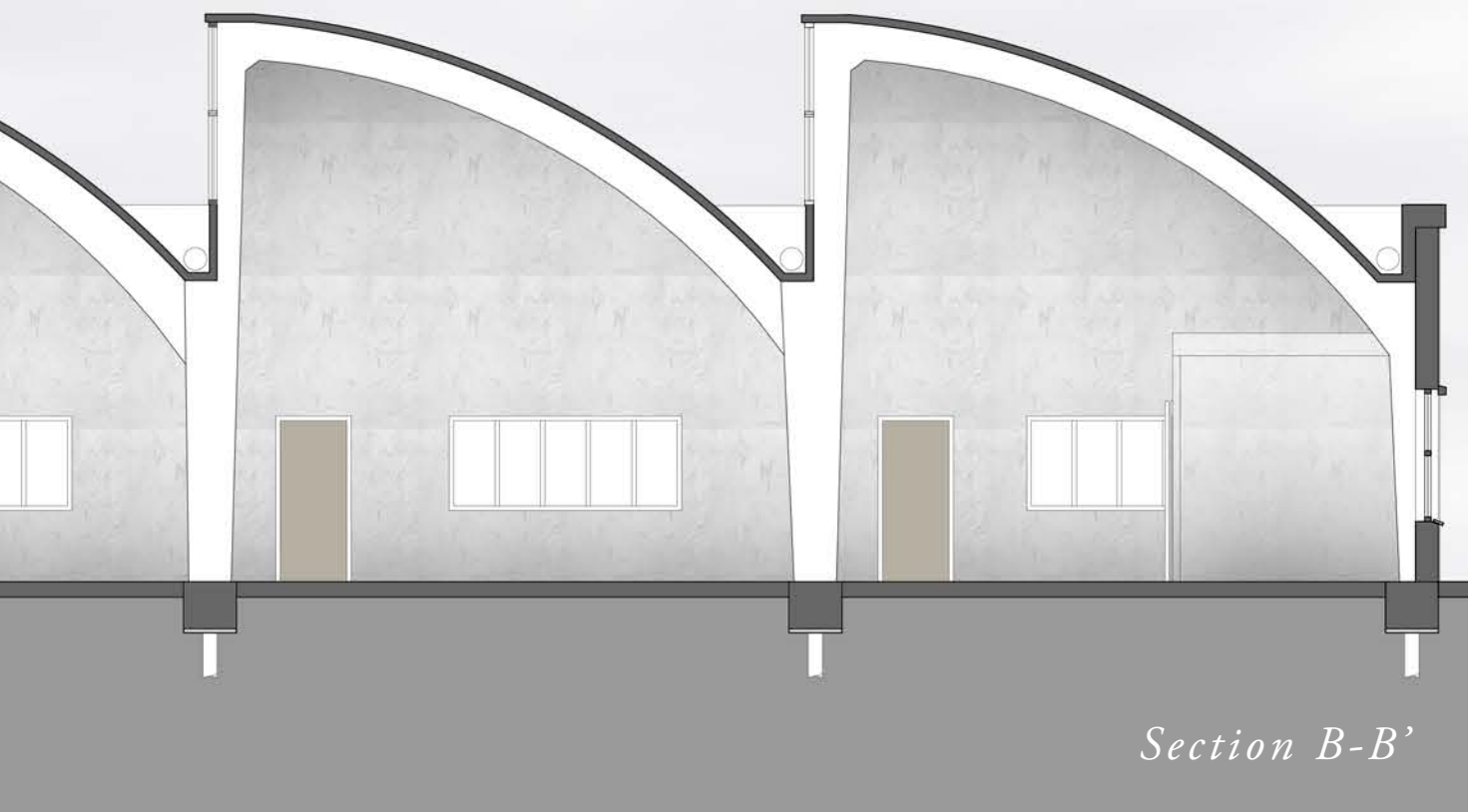

Above:  
Existing Section B-B' of ammunition factory



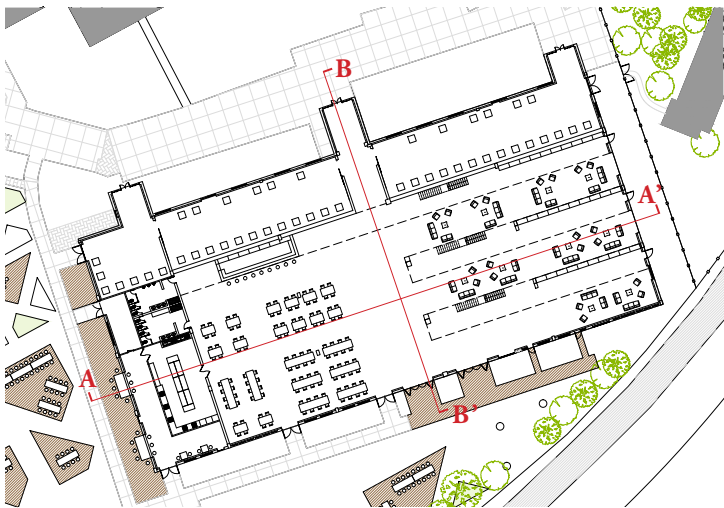
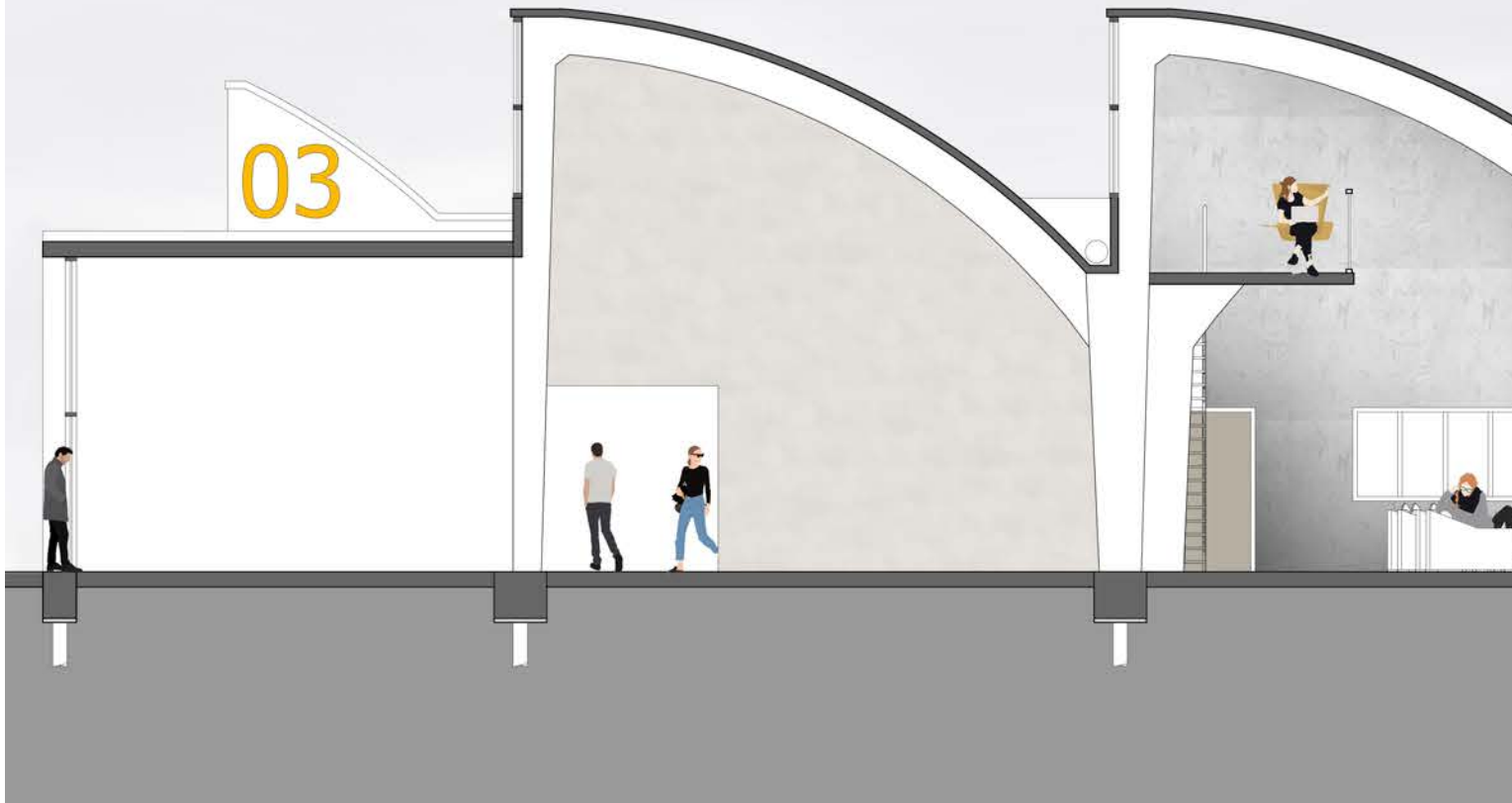





Above:  
Proposed Section B-B' of ammunition factory



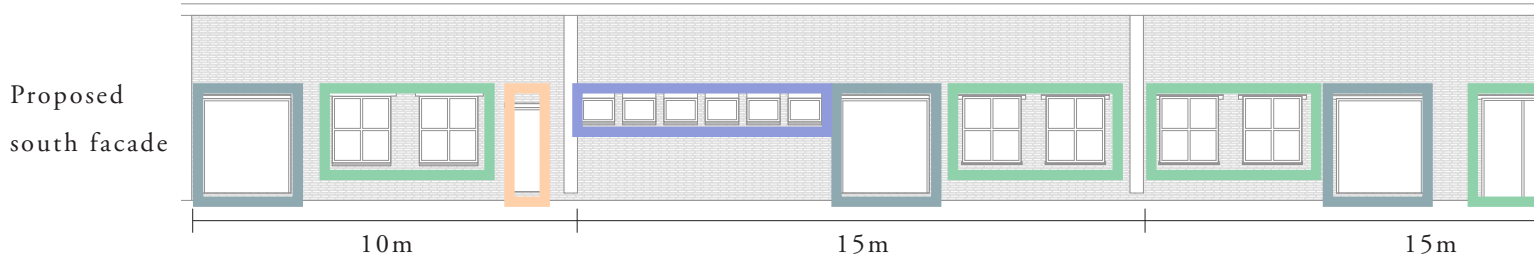
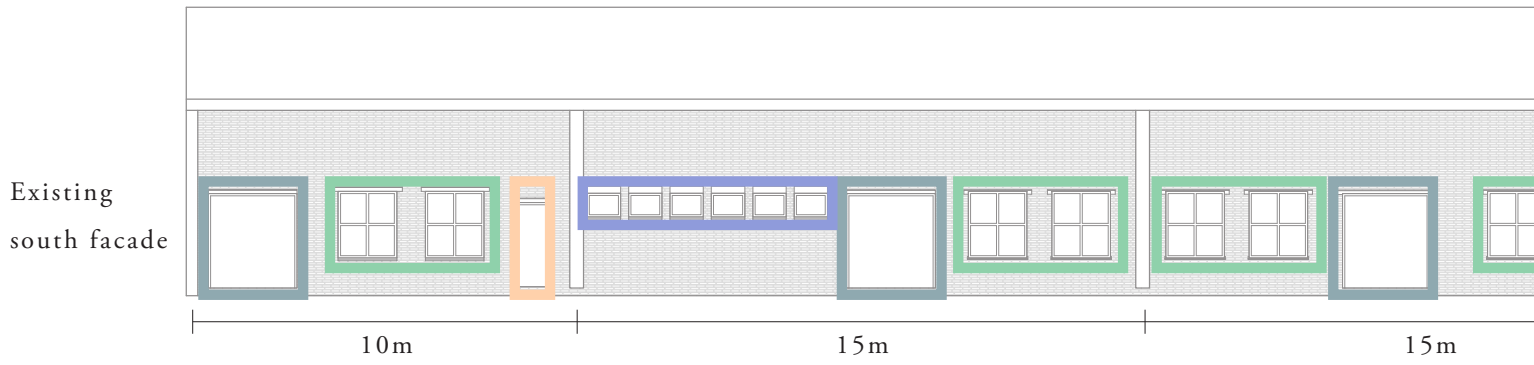

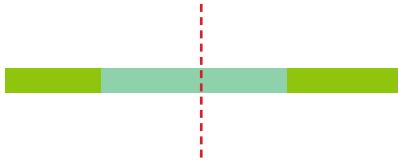

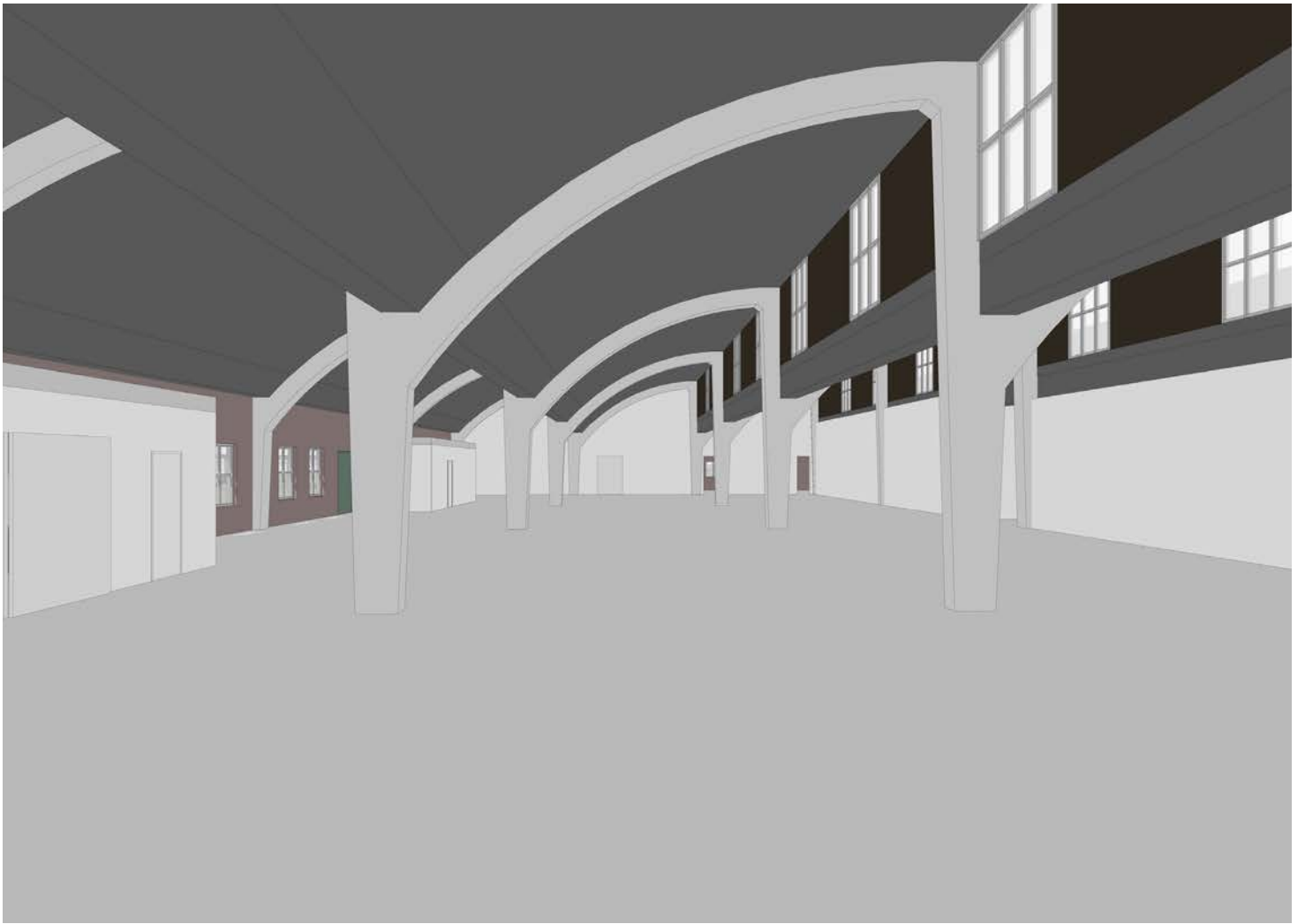

*Before*







*After*





*Before*







*After*



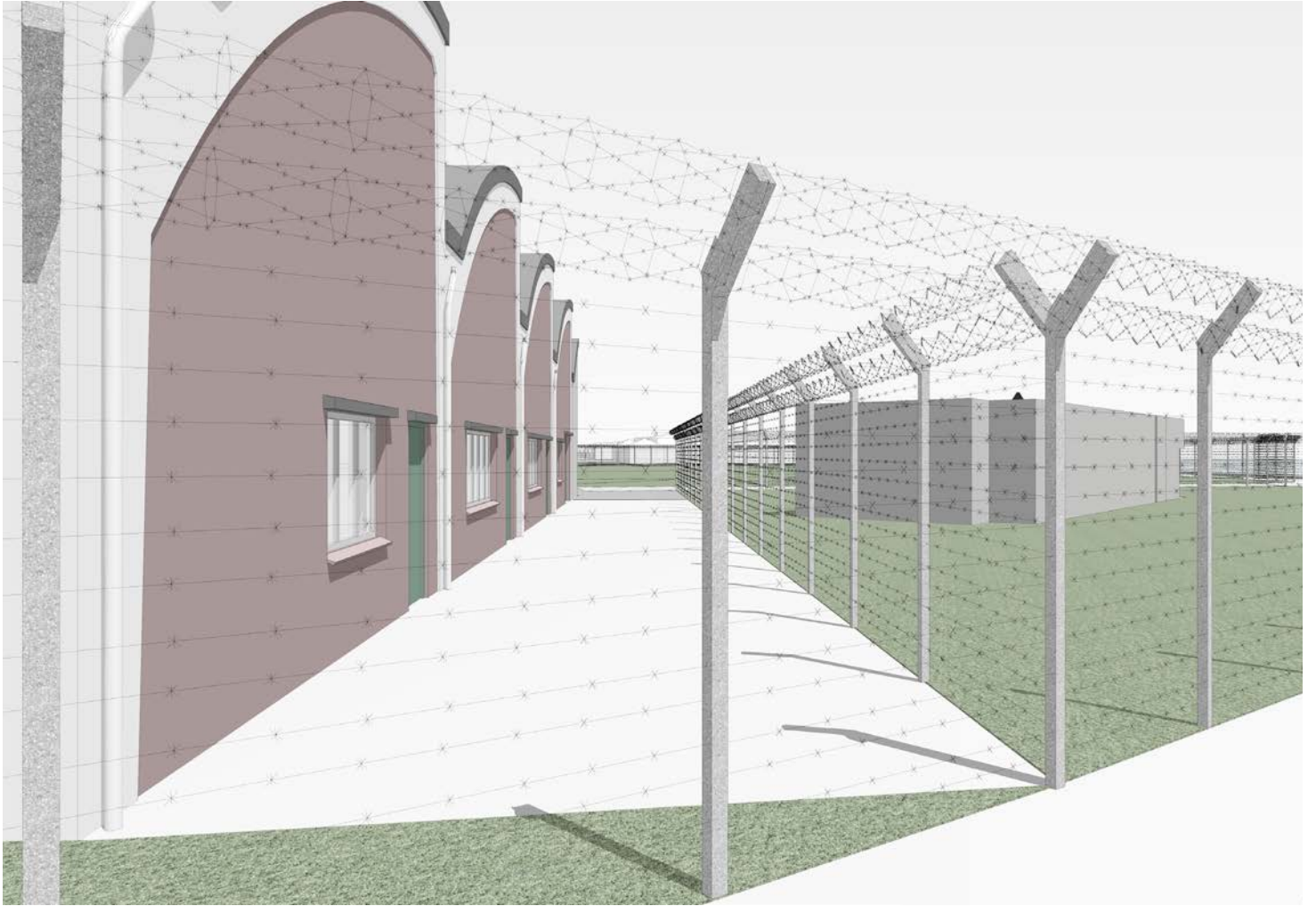

*Before*





*After*

# COMMANDER BUNKER TRANSFORMATION

Existing floor area  $m^2$

Commander bunker 37.52

Total 37.52

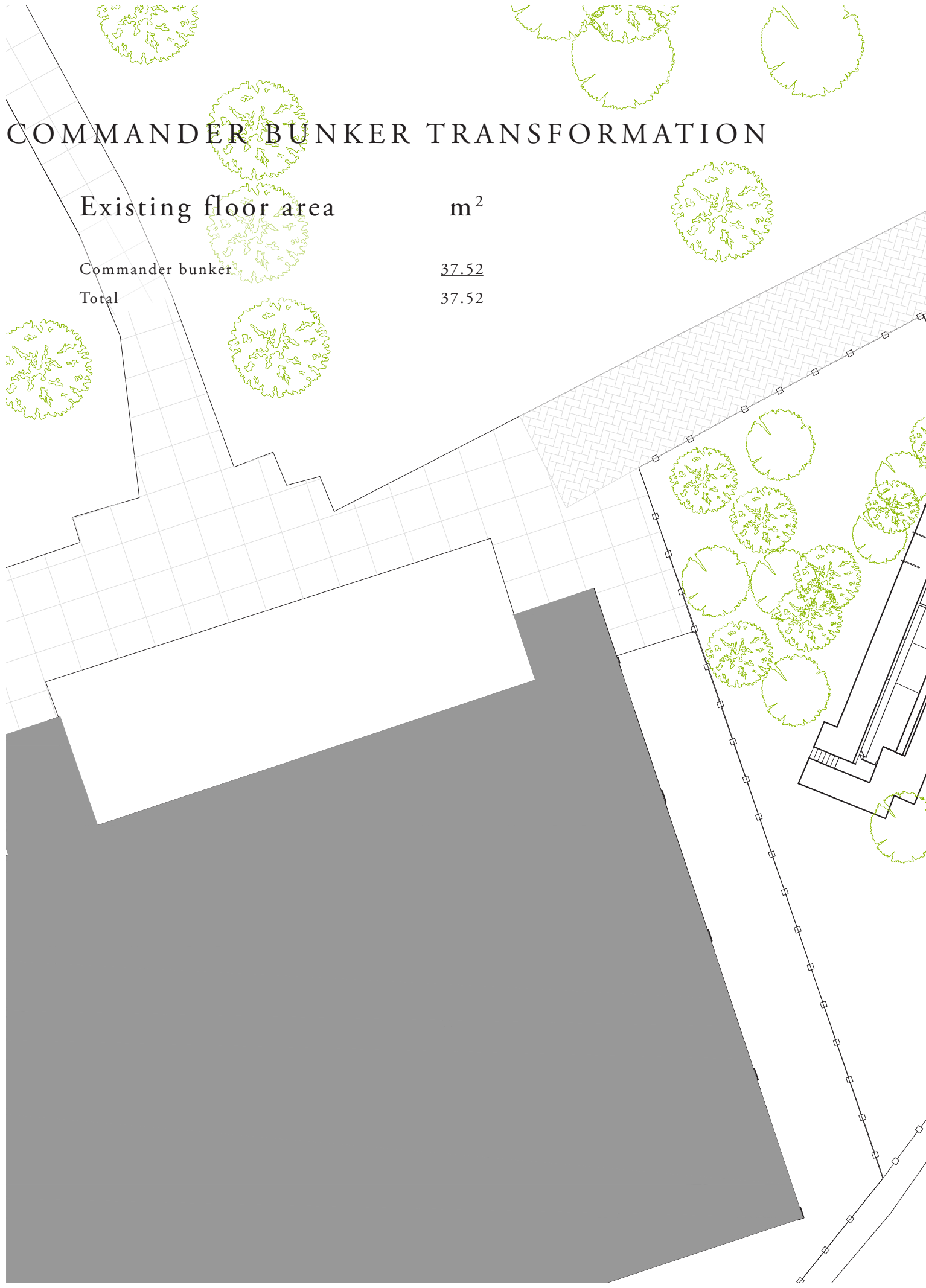

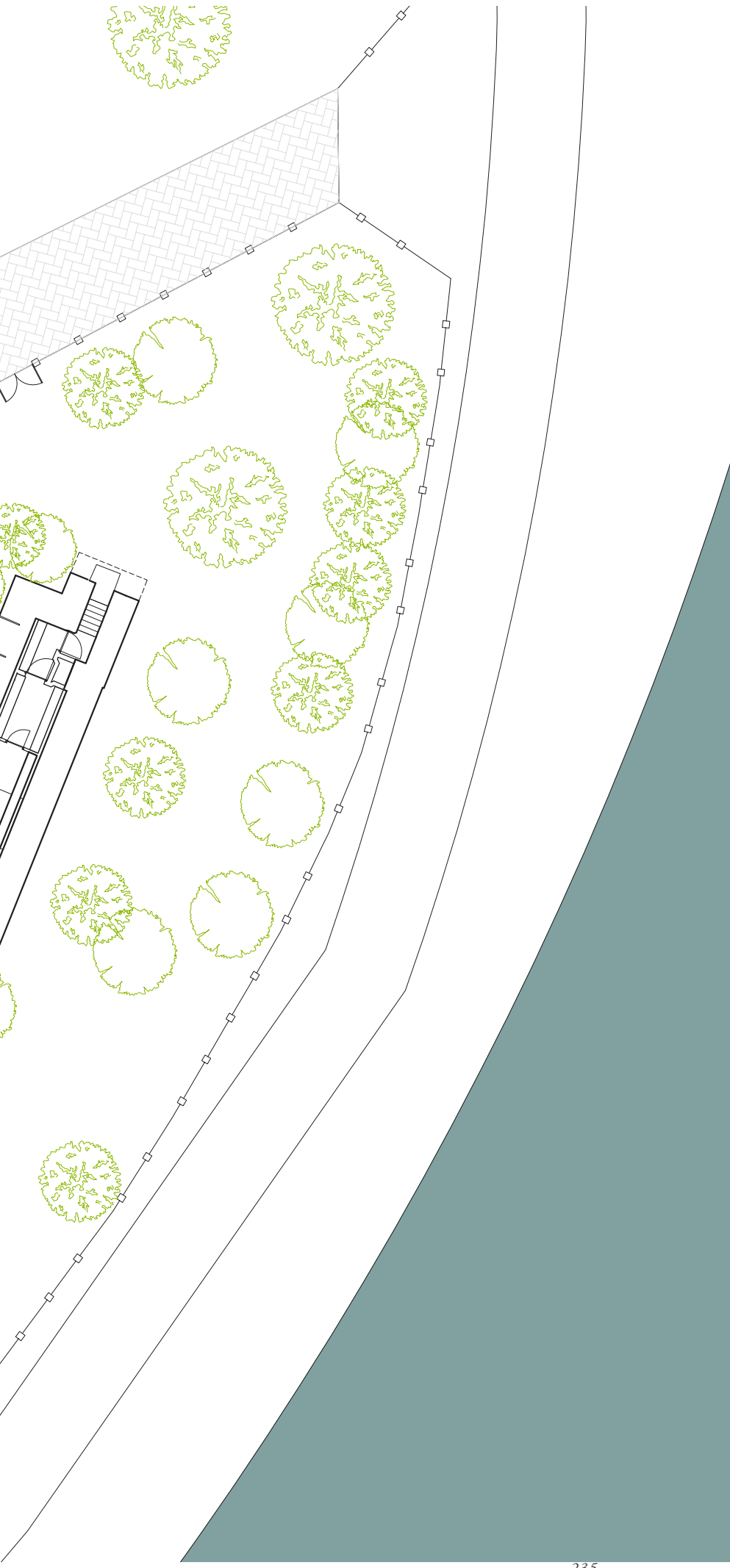

# Proposed floor area

Museum  
Total

m<sup>2</sup>  
37.52  
37.52

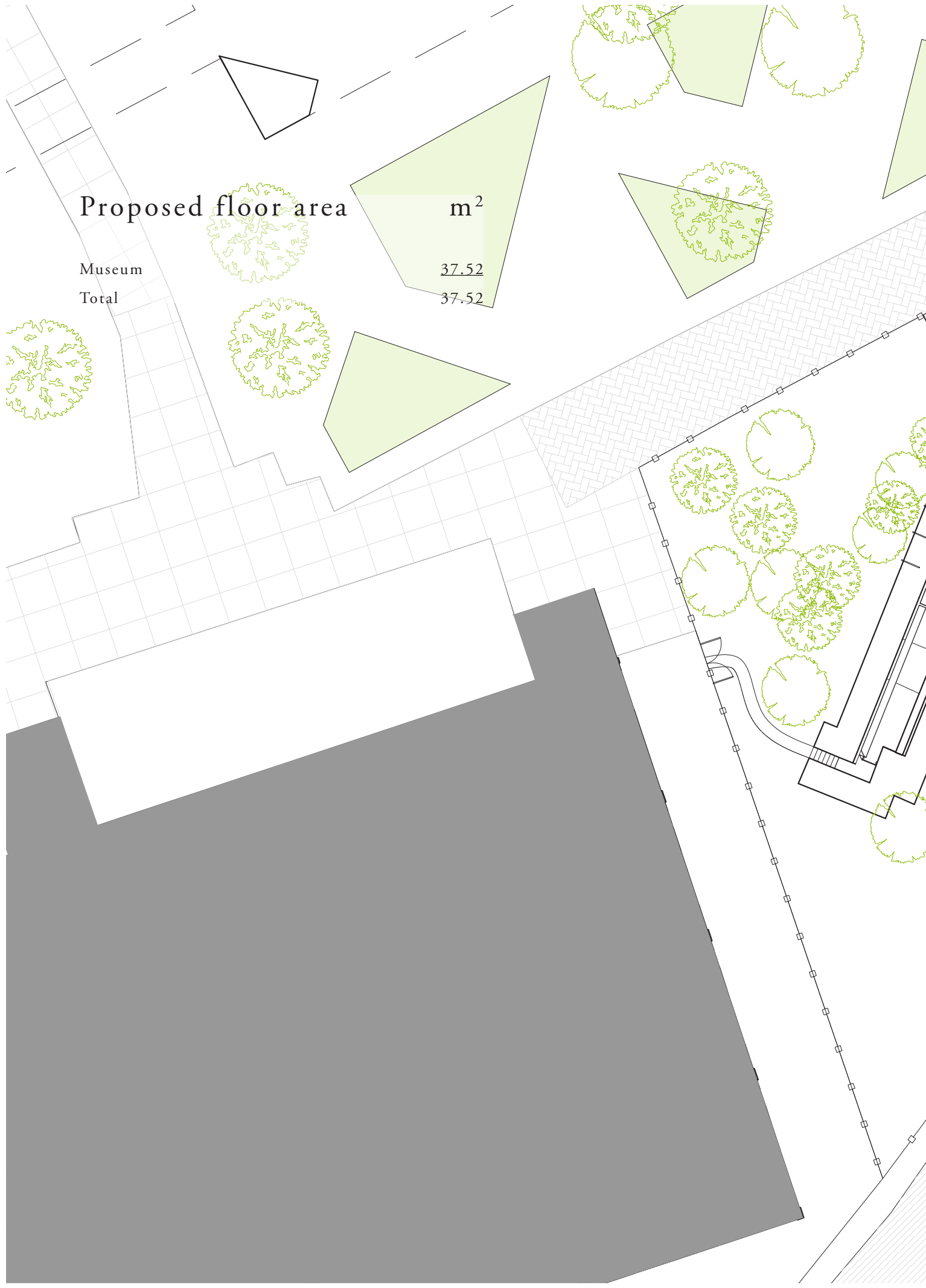



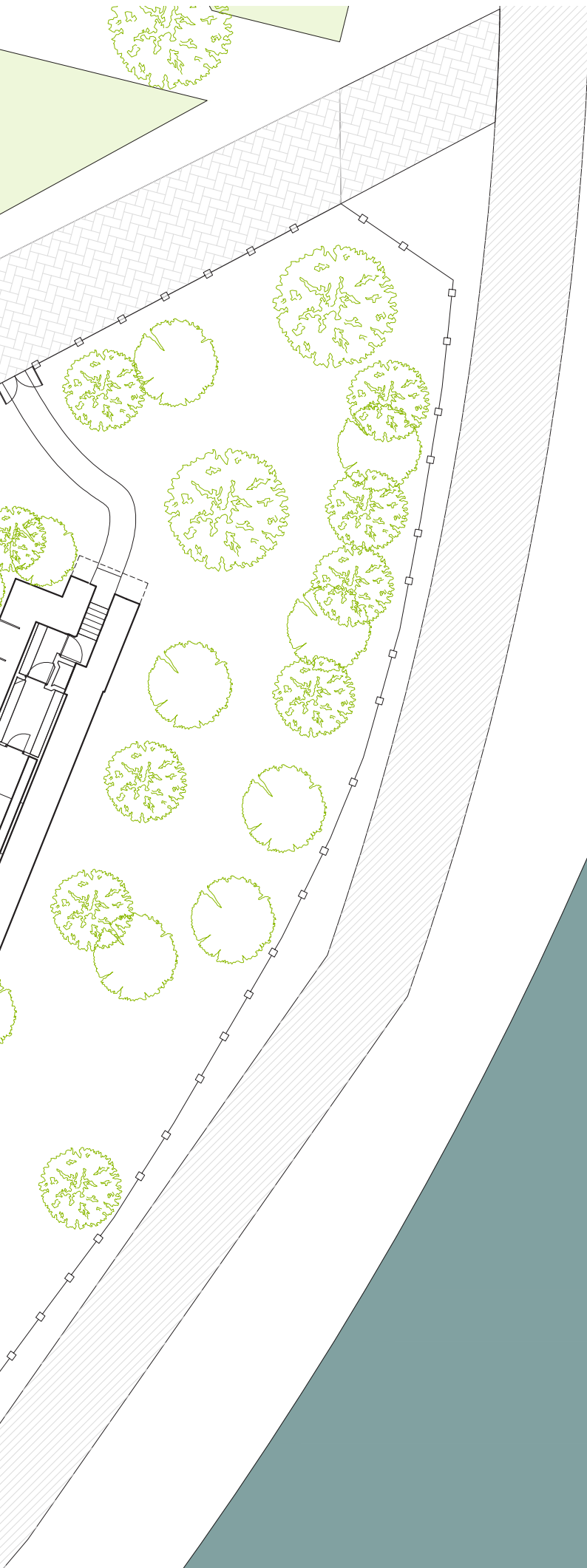

# CAPE NORTH TRANSFORMATION

Existing floor area  $m^2$

Fenced empty plat 5294.49

Total 5294.49

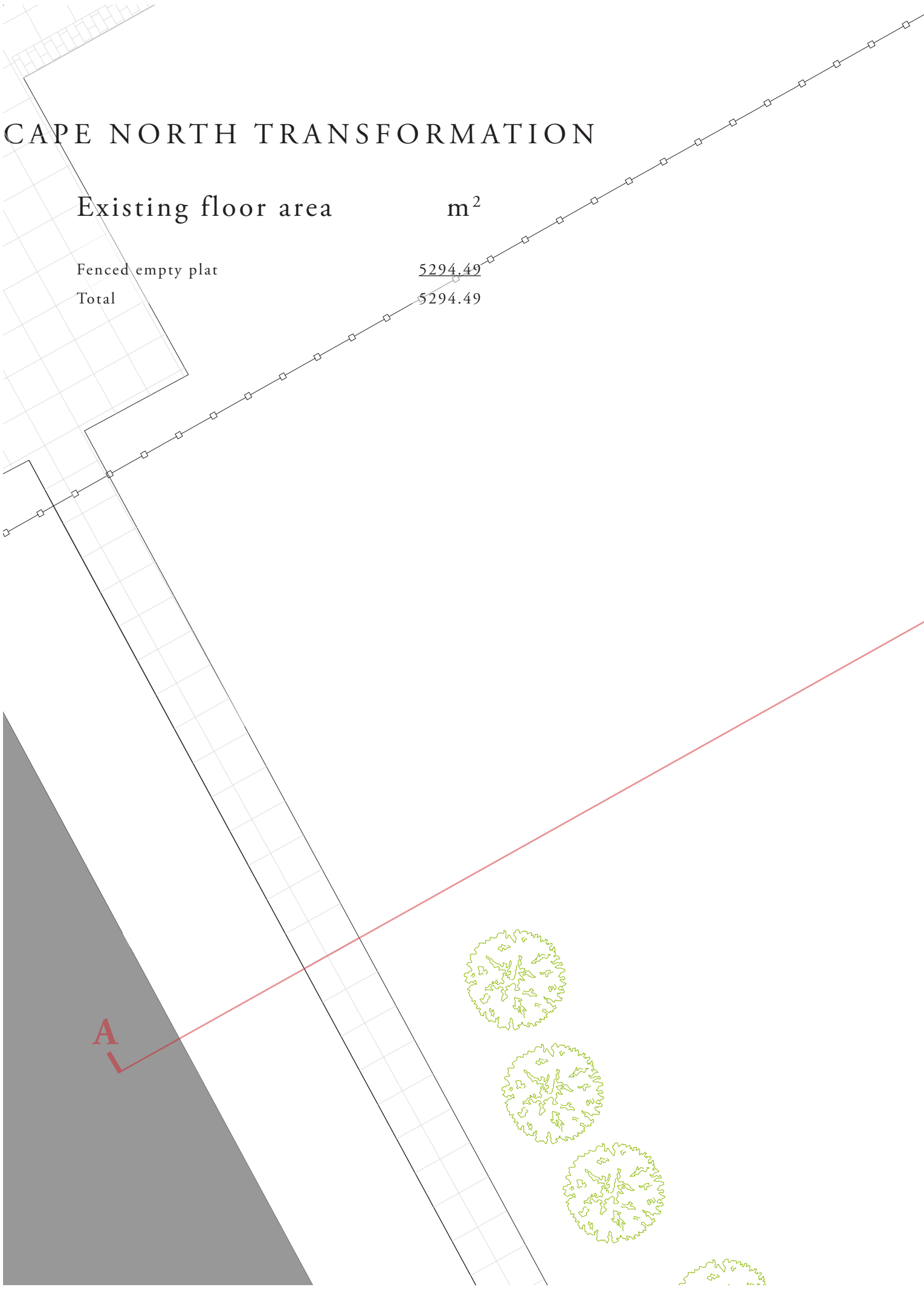

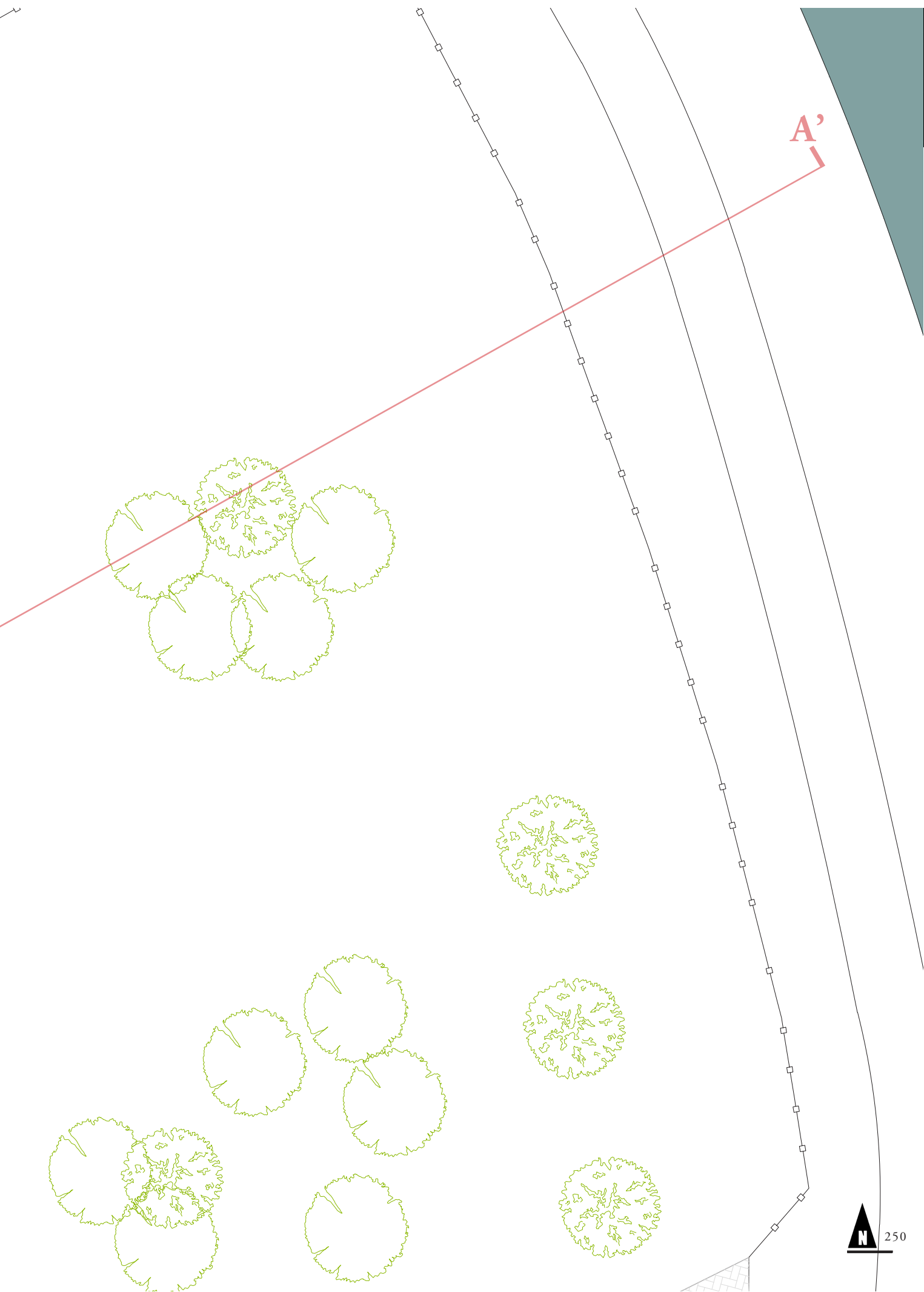

# Proposed floor area m<sup>2</sup>

Black box theater	400
Rehearsal Space	600
Office	200
Performance stage	341.56
Leisure park	<u>6505.58</u>
Total (+45.54%)	7705.58

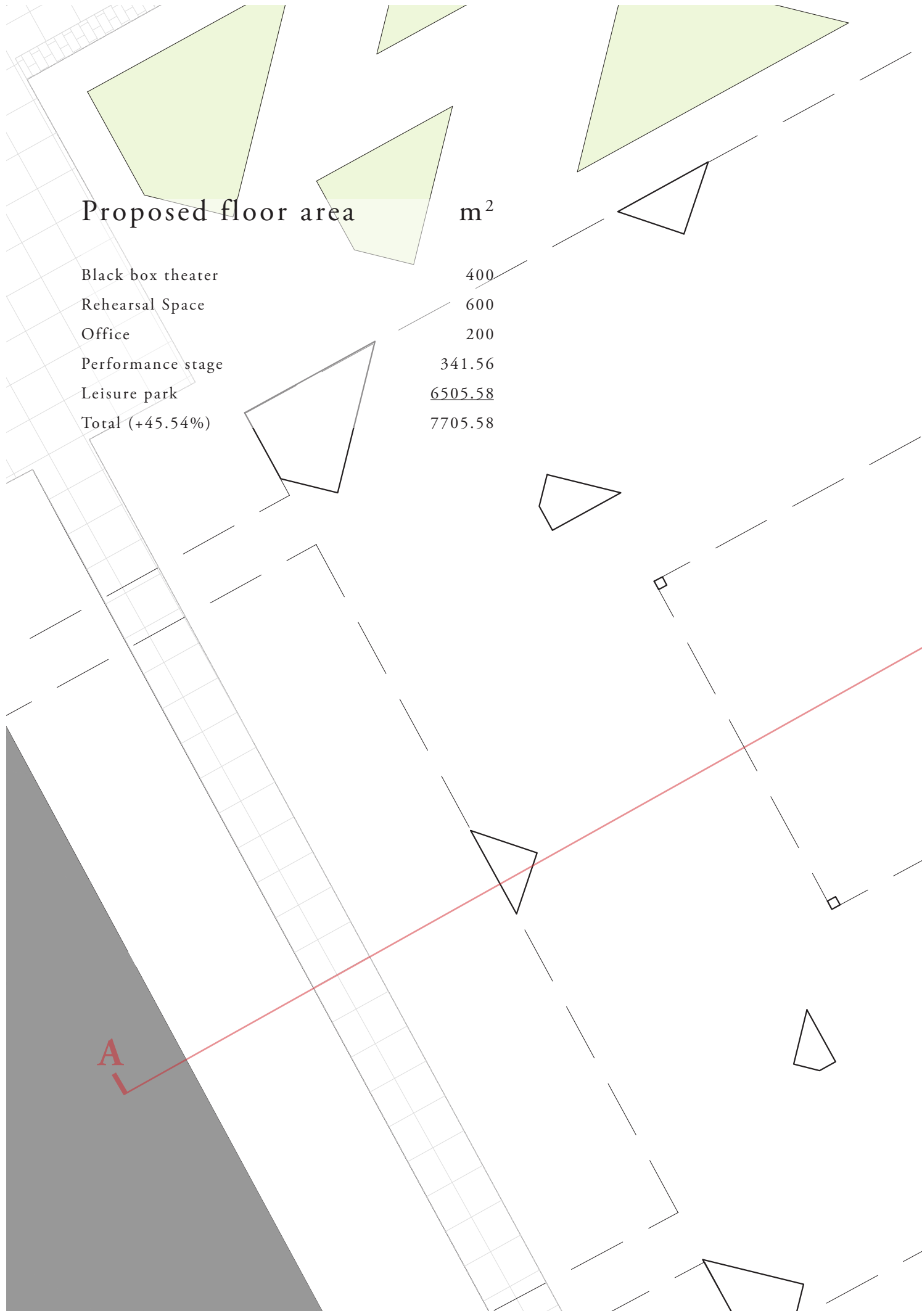



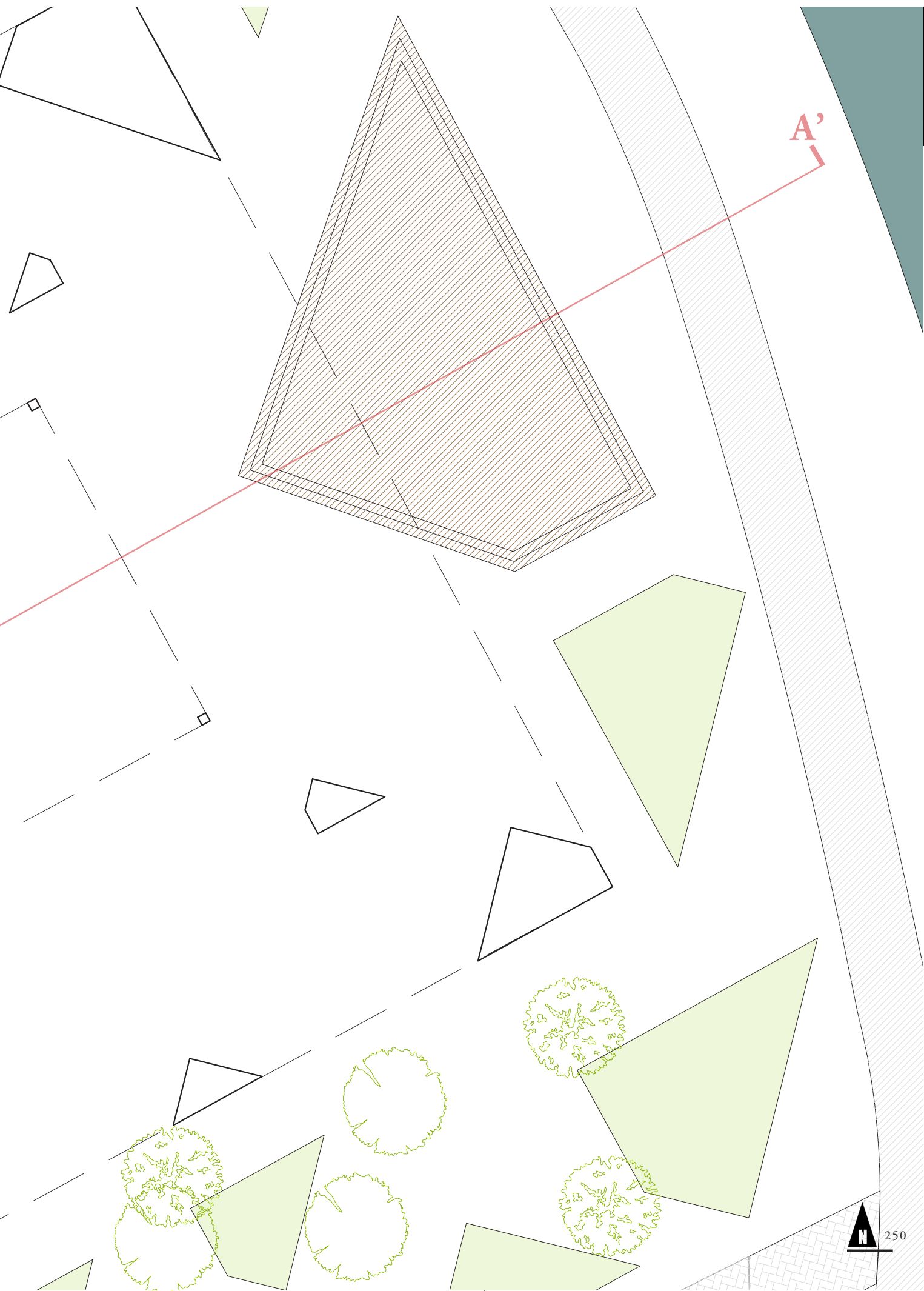

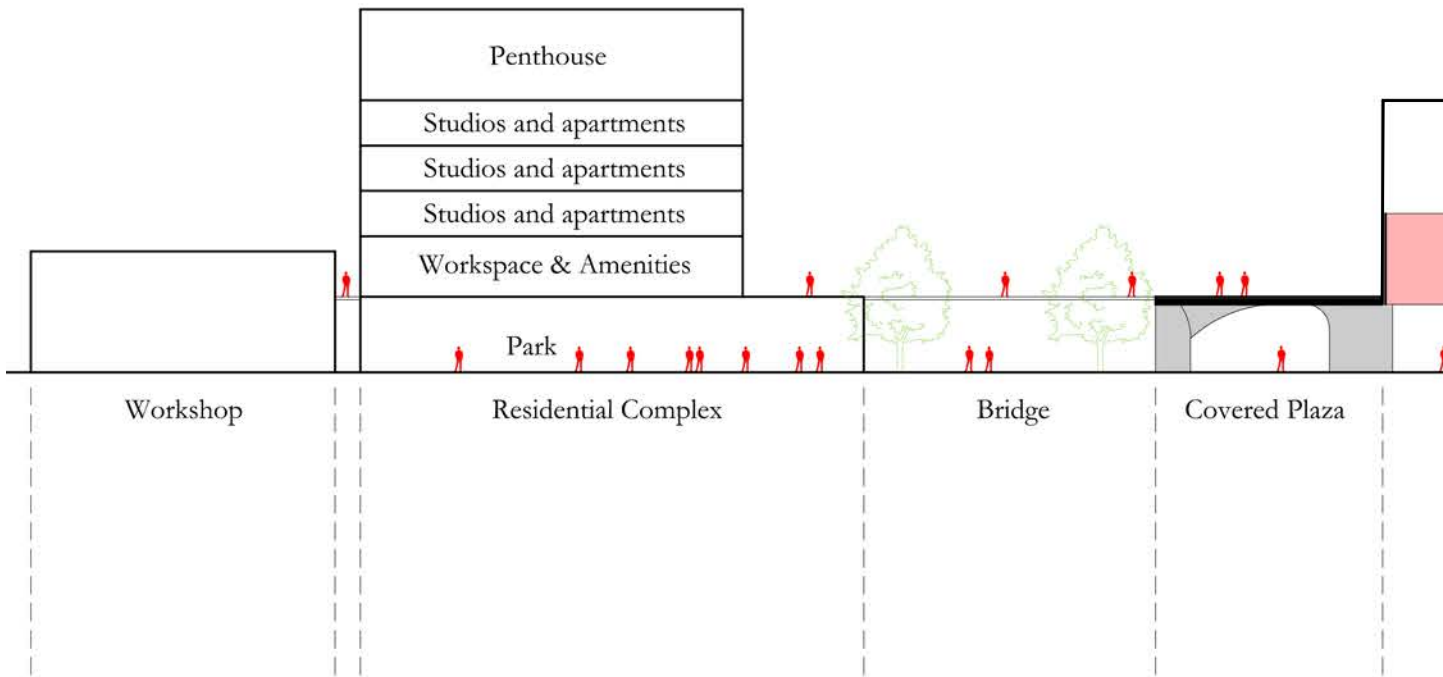
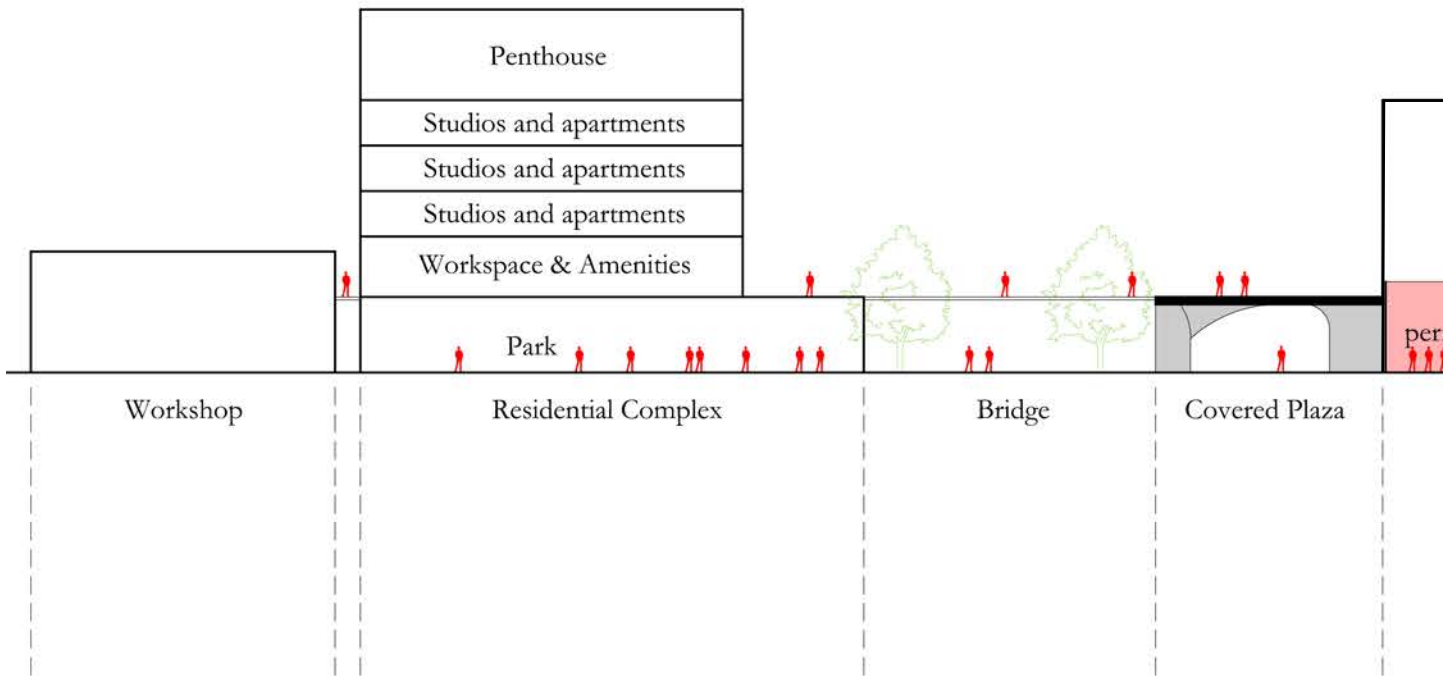

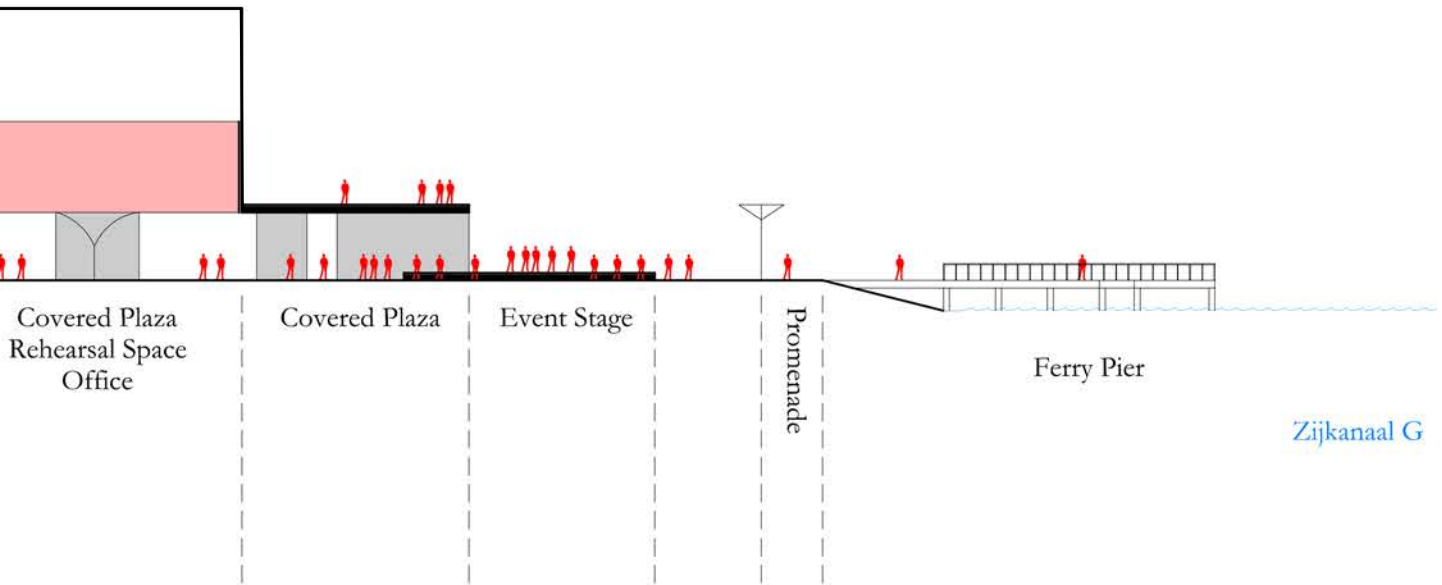
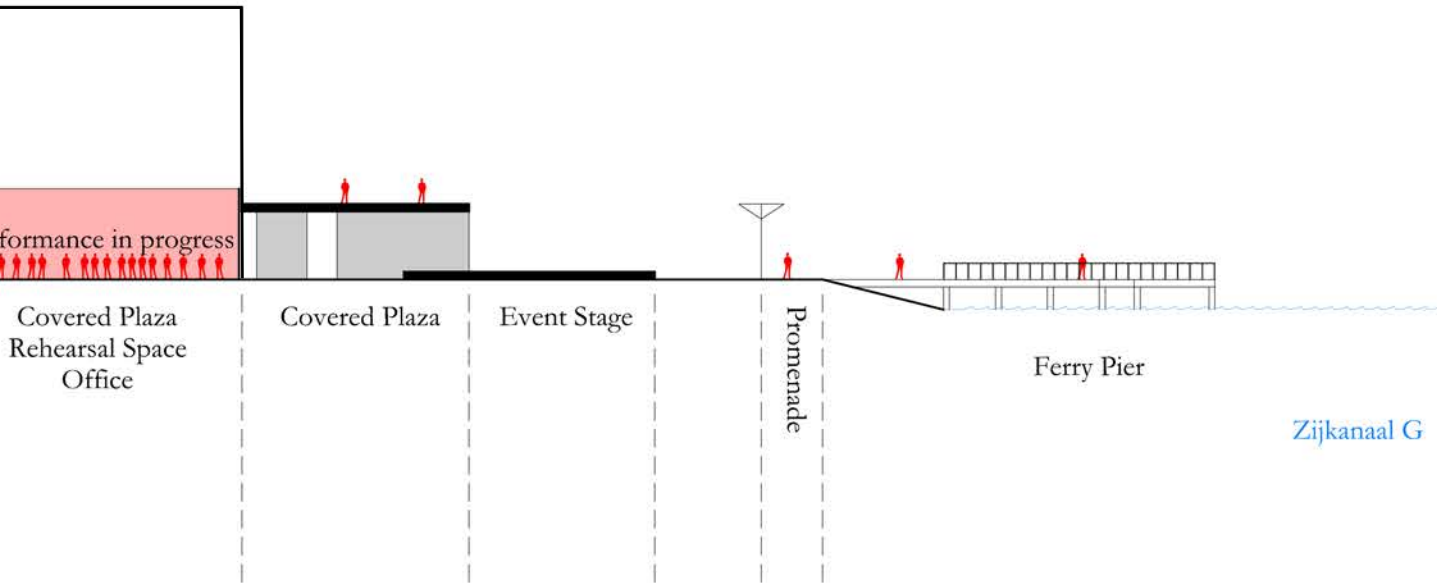

0 500











P3

*When the old and new collide...*



LEARNING FROM LOCHAL







Project name: LocHal Library  
Location: Tilburg, Netherlands  
Architects: CIVIC architects, Braaksma & Roos architectenbureau, Inside Outside, Mecanoo  
Built in: 2018  
Area: 11,200m<sup>2</sup>

### **Introduction**

To kick off the studio after a long holiday, we have traveled to Tilburg to visit two examples of heritage transformation. The first building that we looked into is the LocHal.

The LocHal was once a busy workshop where wagons and locomotives were developed and repaired. From 1932 until the closure in 2009, it was a place where hundreds of Tilburgers found their jobs. This sturdy steel building composes the collective memory of the city. The most important aim for the redevelopment was to give the LocHal back a second life to the people of Tilburg, in the form of a lively knowledge workshop - A public library which carries the strong traces of industrial heritage inside.

*Photo Source:*  
<https://www.civicarchitects.eu/bibliotheek-tilburg.html>

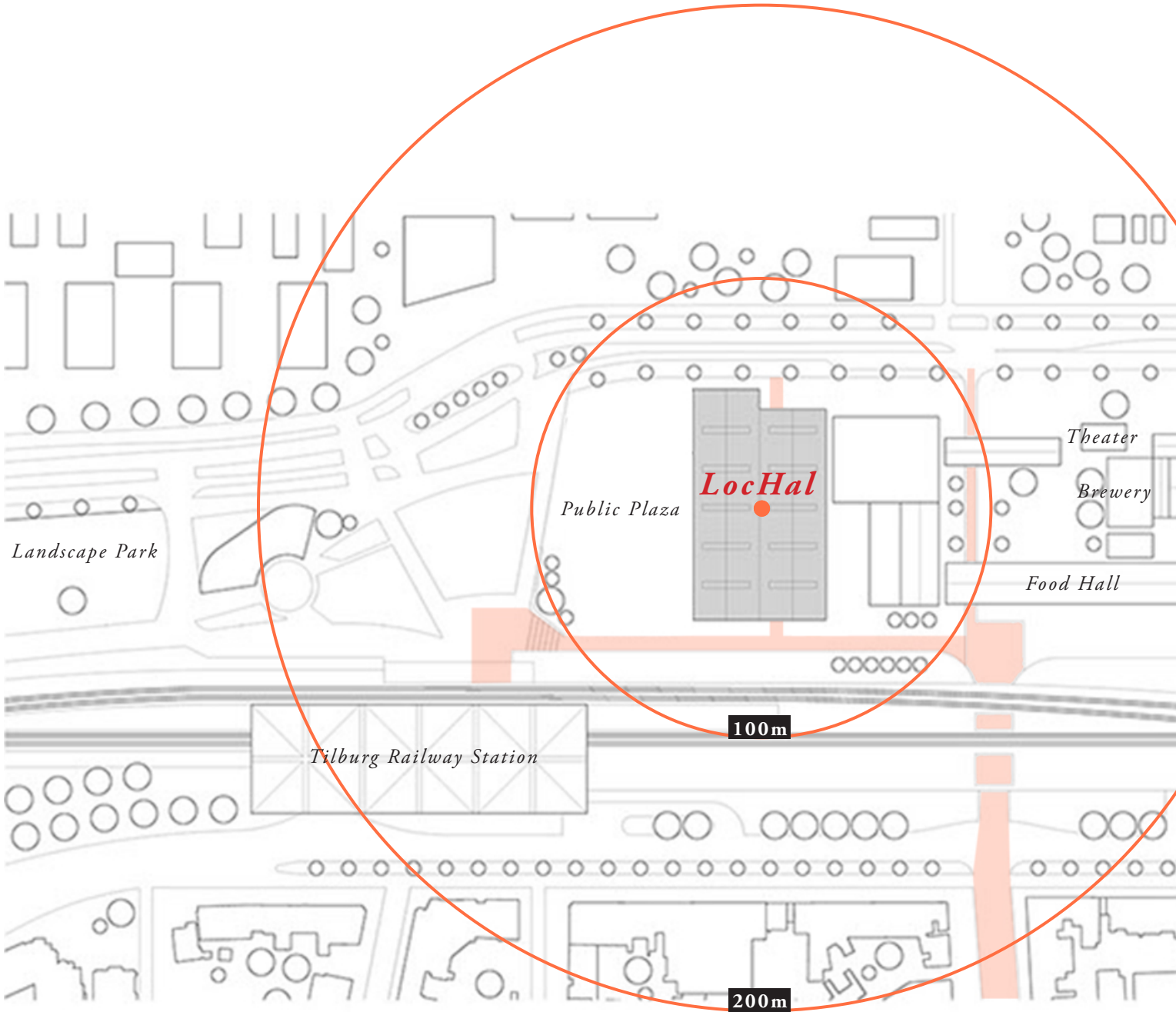

*Connected public circulation*



*To City Center*

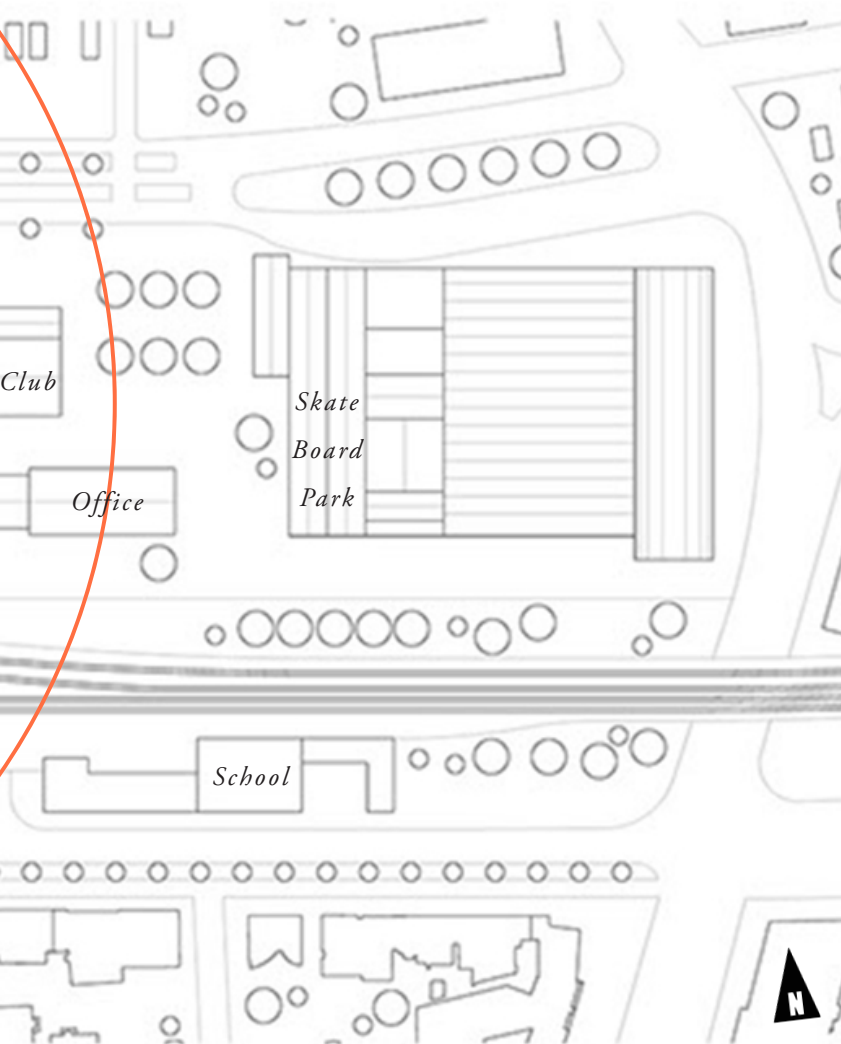

### Site Context - Continue the urban fabric

Impressed by the spaciousness, the monumental emptiness and the huge size of the LocHal, the design team realized that the LocHal is more than a building; it is a part of the city. They connect the industrial hall with the city as one continuous urban fabric. The construction of the LocHal catalyzes the redevelopment of 75ha (750,000m<sup>2</sup>) railway area in Tilburg. The building unites and activates public routes and places all around. Its location in the middle of a public transport node and the transparency of its construction have successfully turned the building into an attractive hub for sharing knowledge and information for the entire region.

*Photo Source:*  
<https://www.civicarchitects.eu/bibliotheek-tilburg.html>



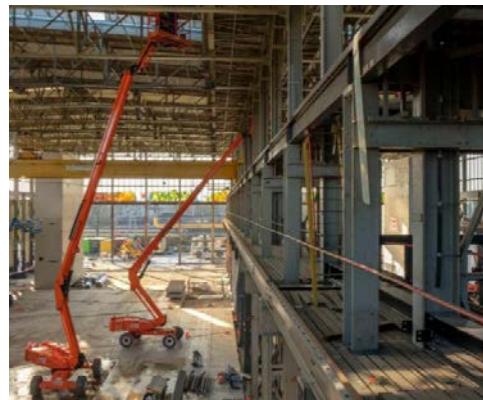
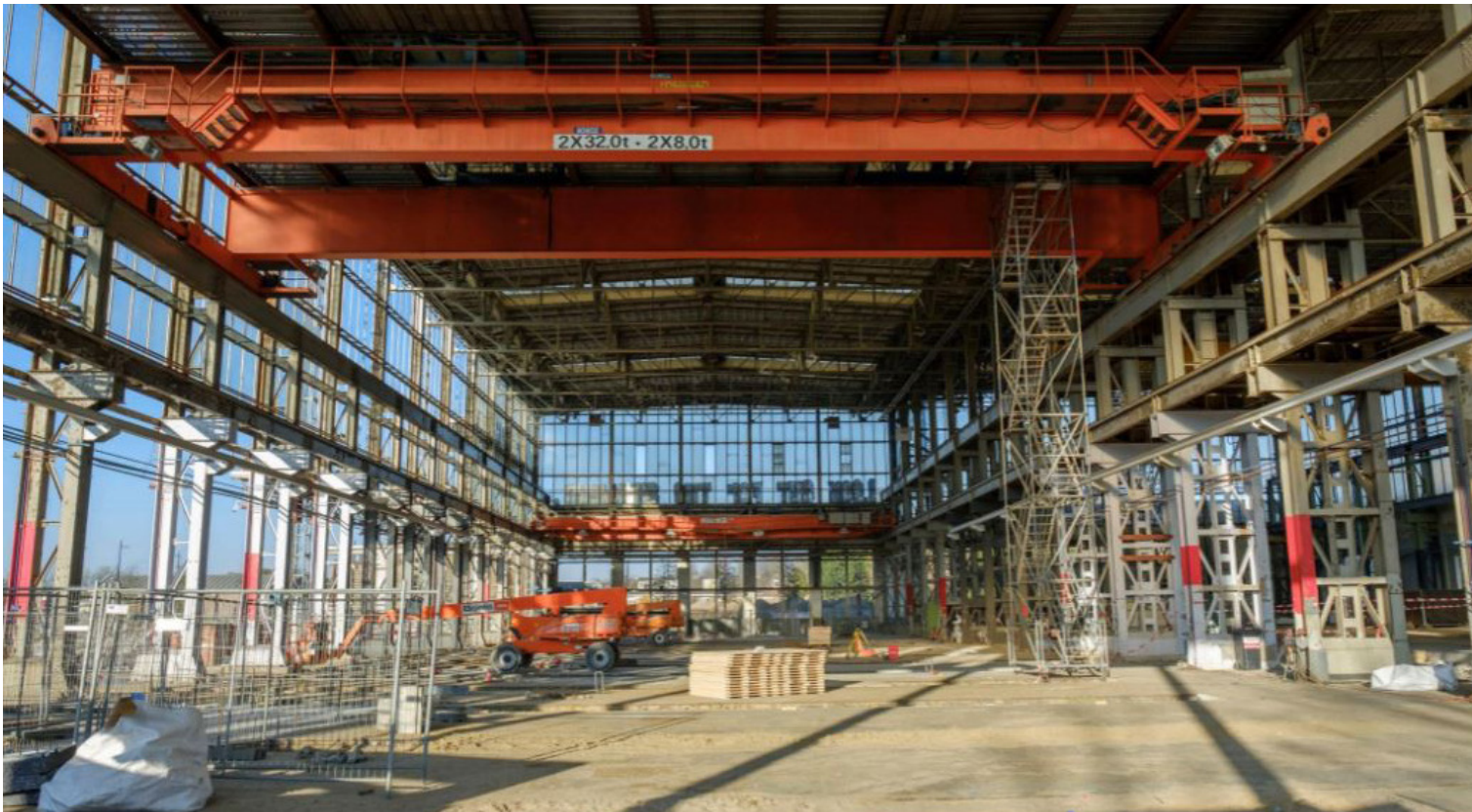



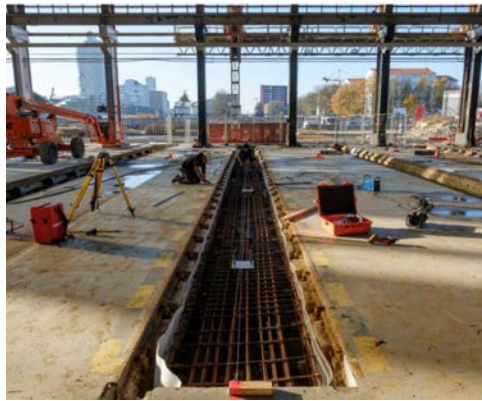

*Construction  
Process*

*Photo sources:  
Frans Parthesius, LocHal Tilburg,  
Album 1 / November 2015 - April 2018*

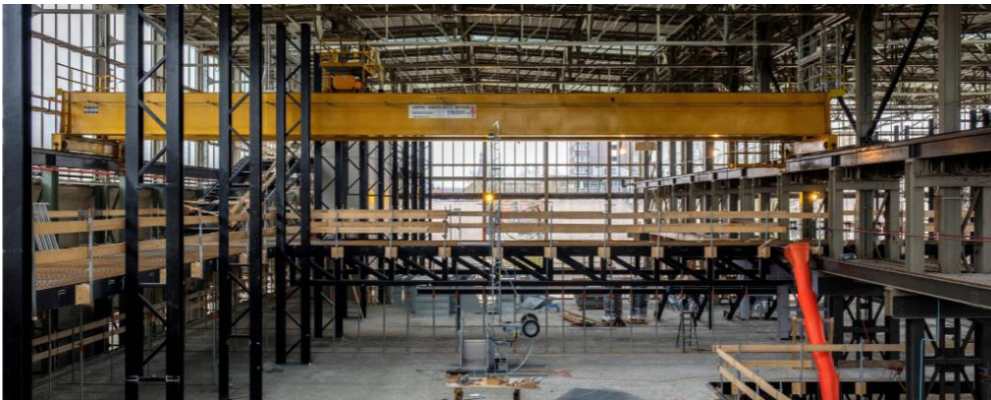



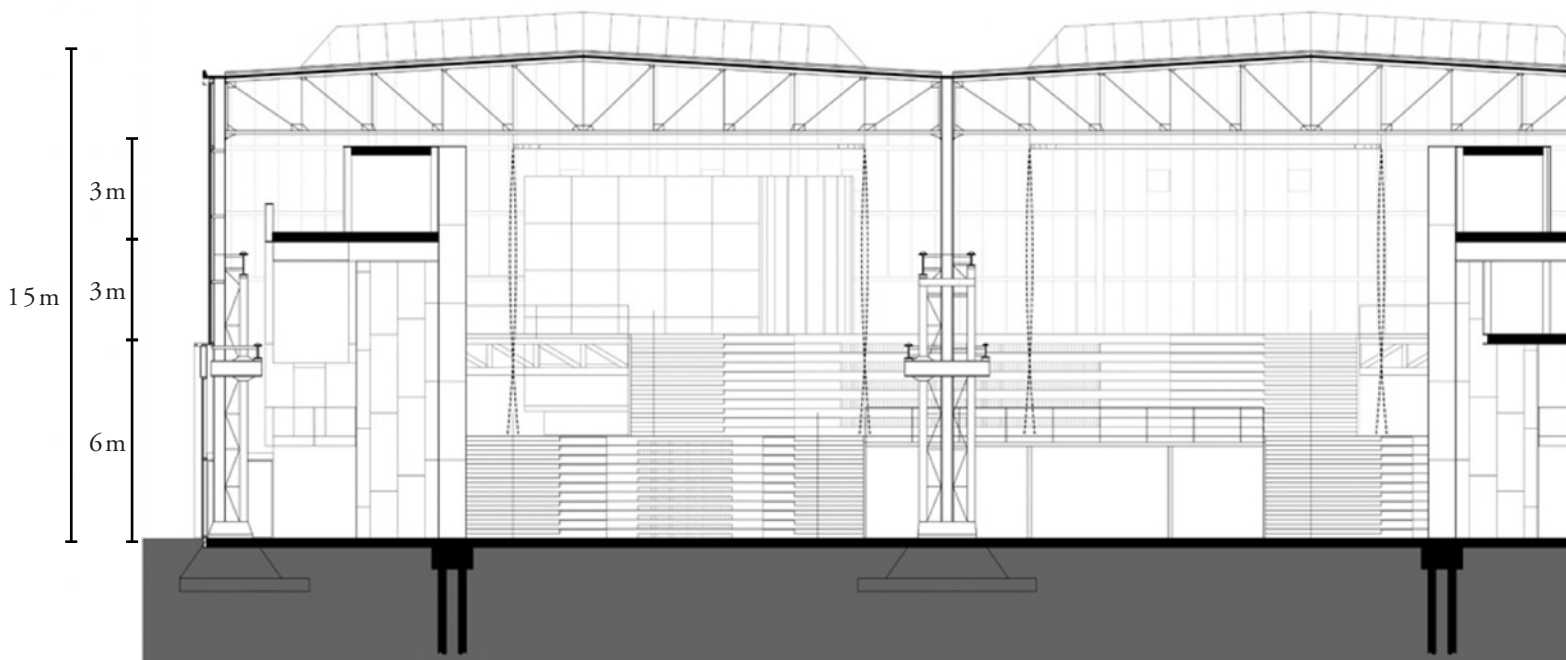
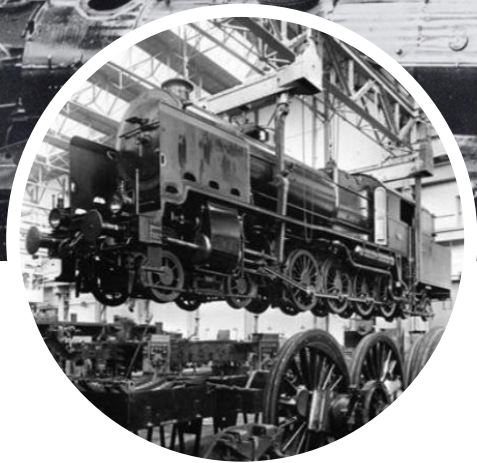
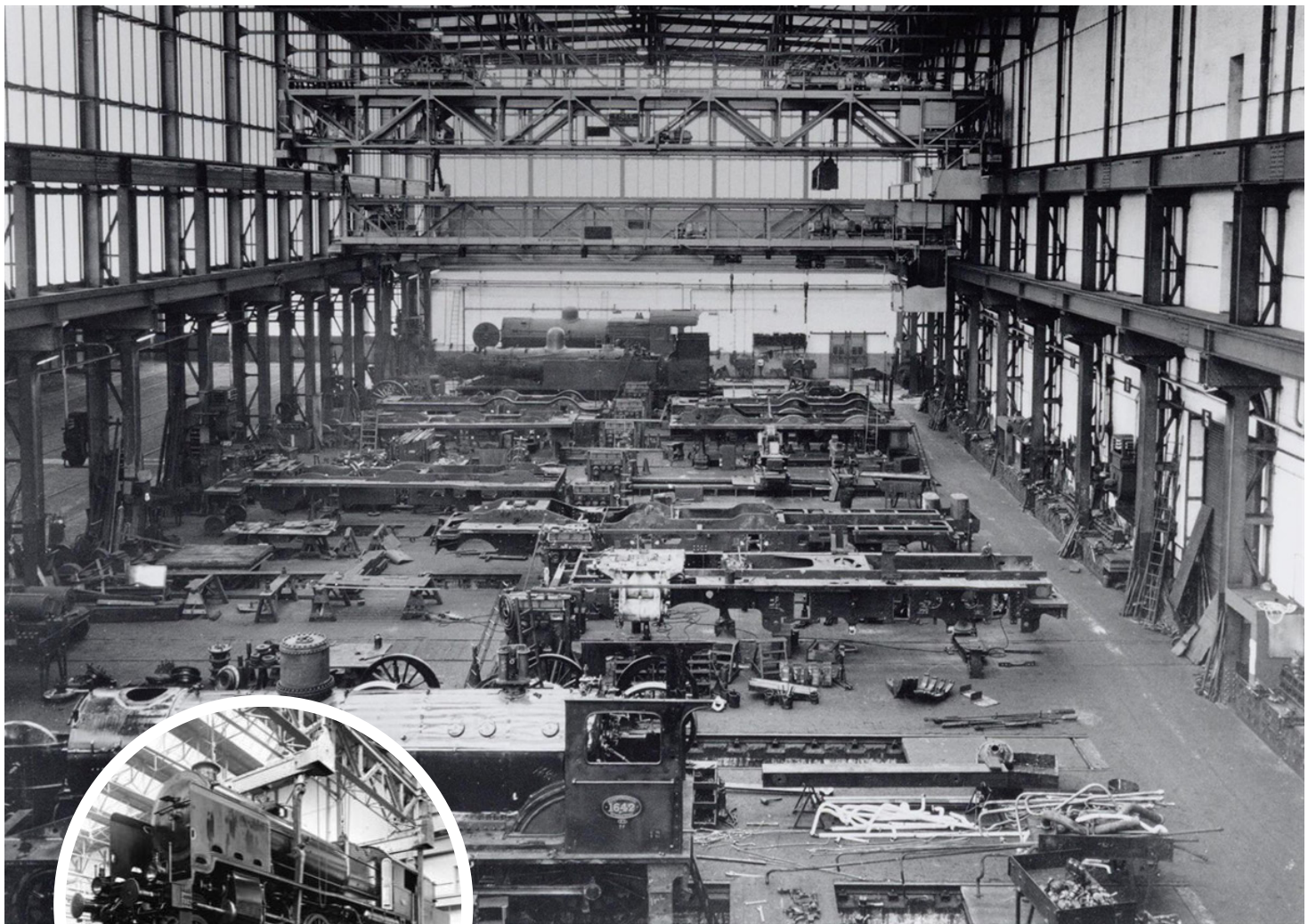

### Scale - From massive scale to human scale

As a former locomotive repair workshop, the LocHal has an expansive spacious layout and a high ceiling. The 15 meters tall hall was designed to lift up the train for maintenance, however, the massive scale no longer fits the new function. The architects broke down the vertical scale by adding stairs and floors to create an imitate sense of scale for the library users.

*Top:*  
The hall with unison ceiling height before intervention.

*Middle:*  
The train was lifted up by crane for maintenance.

*Bottom:*  
Section A-A' of LocHal

*Photo sources:*  
<https://www.mecanoo.nl/News/ID/434/Mecanoo-completes-interior-design-for-LocHal-a-world-class-library-for-Tilburg>

<https://www.civicarchitects.eu/bibliotheek-tilburg.htm>

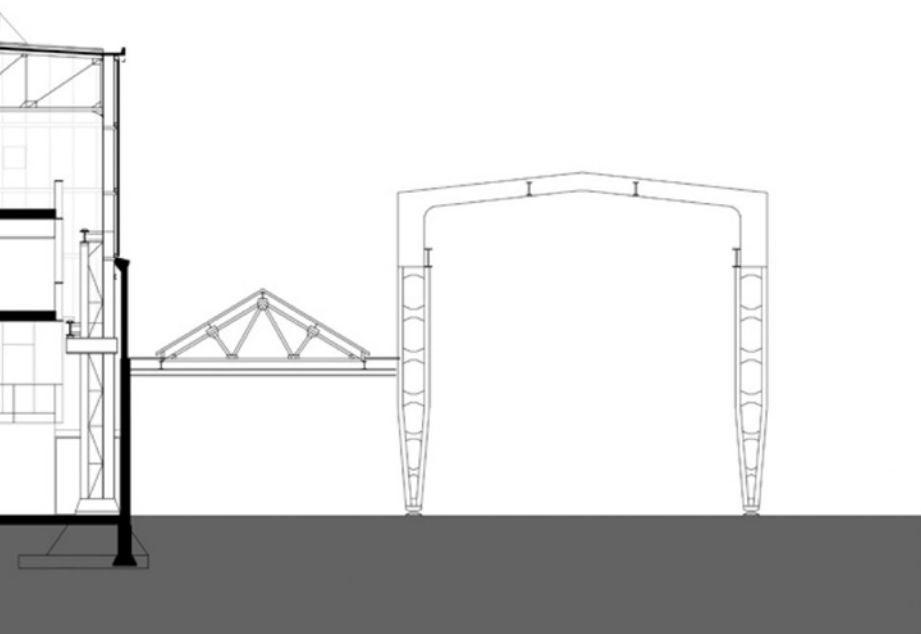



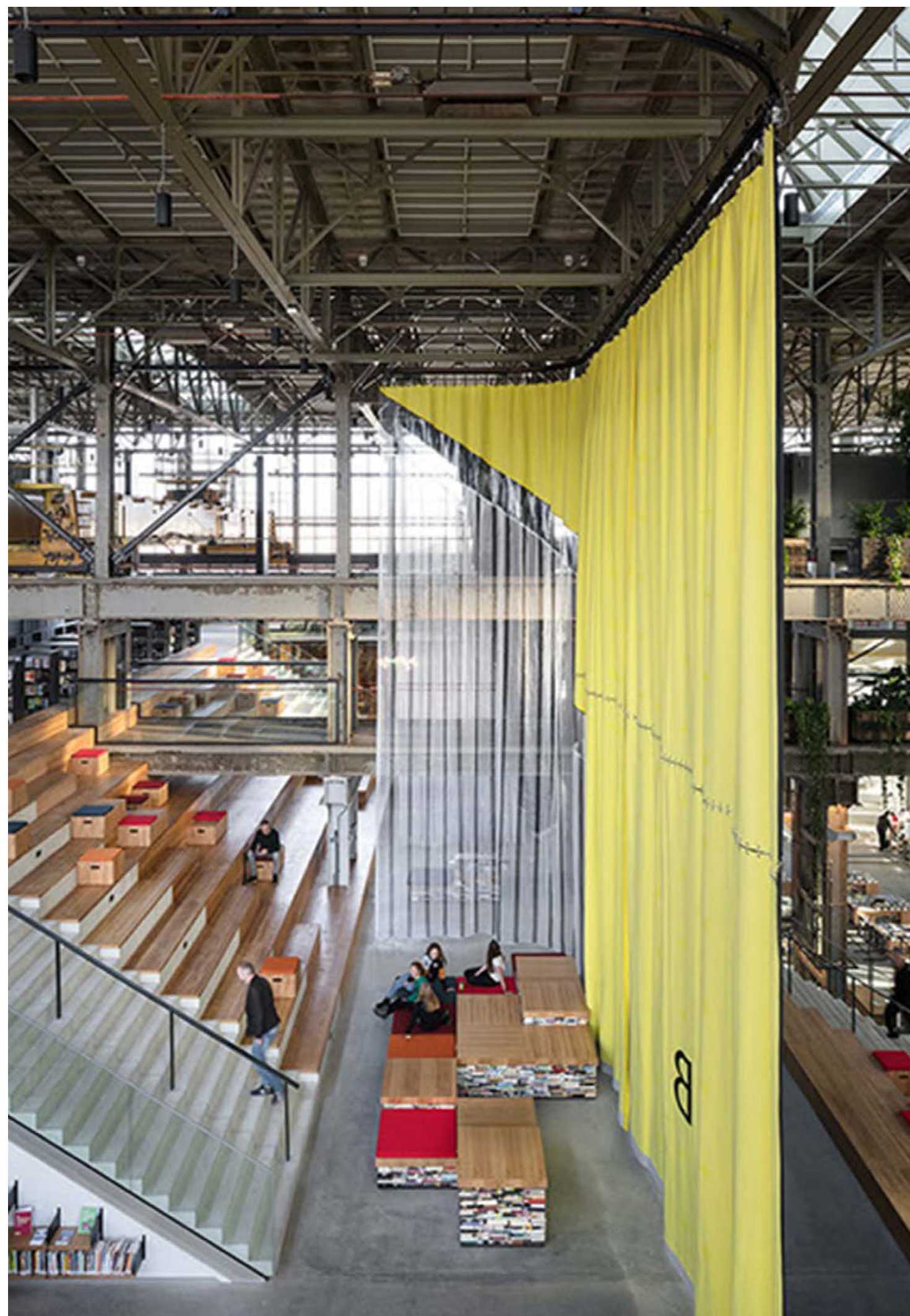



The ascending staircase landscape makes what was previously unreachable now almost tangible: the crane tracks, the rails and the impressive steel construction with the old layers of paint still visible. The new interventions do not disturb the openness on the horizontal plane. Six enormous movable textile screens accentuate the scale of the building, define different spaces and improve acoustics. The six canvases make it possible to insulate large and small workspaces or to transform the staircases into a theater or a lecture space. The transparent material also allows daylight to penetrate into the library space.

*Left:*  
*The suspending textiles offer the possibility to transform or isolate the workspaces*

*Photo source:*  
*<https://www.civicarchitects.eu/bibliotheek-tilburg.html>*

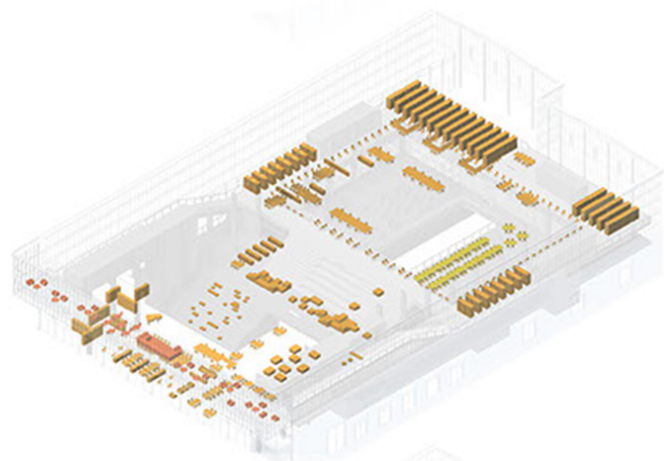
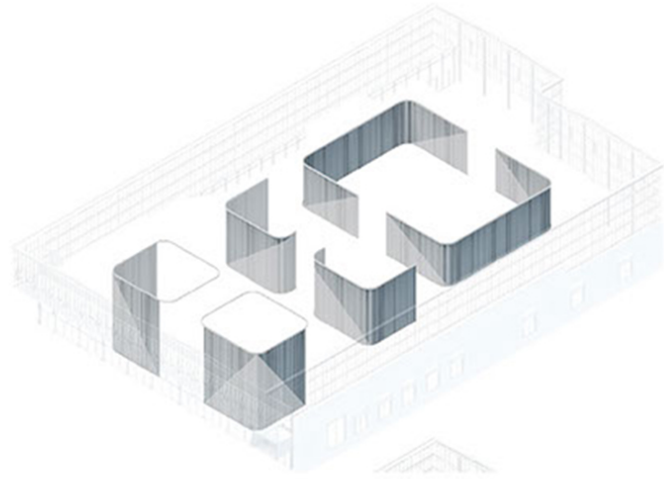
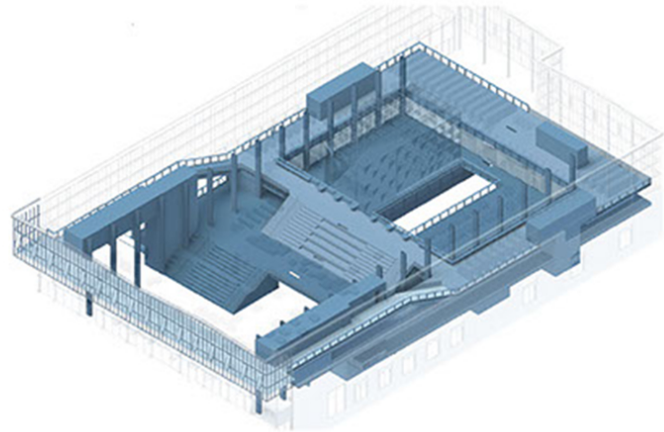
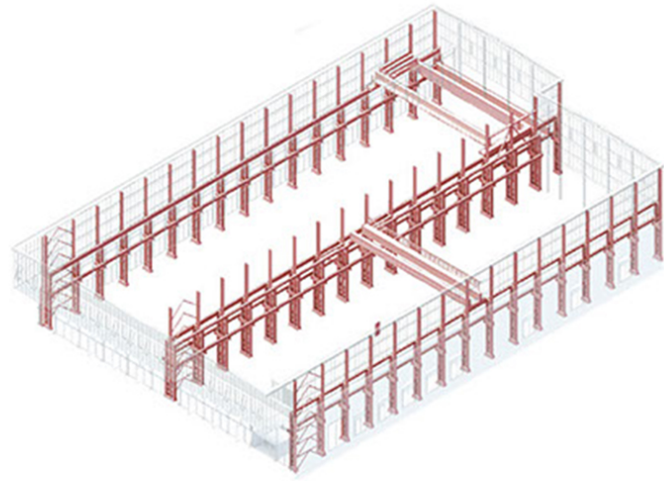

**The Structure:**

The skeleton of the historic Locomotive Hall set the starting point for the new library. The previously existing structure is retained and serves as a guide to direct visitors through the building.

*Photo source:  
[https://www.civicarchitects.eu/  
bibliotheek-tilburg.html](https://www.civicarchitects.eu/bibliotheek-tilburg.html)*

**The Infill:**

The new infill, including the staircases, floors and corridors coincide with the hall and make the LocHal an impressive public place: An open knowledge workshop with various labs and space for events. The new floors use the full load-bearing strength of the original floors and beams, which were after all designed to support heavy locomotives.

**The Zoning:**

Different zones for lectures, events and exhibitions are divided by six massive movable screens. It allows high flexibility in creating varied space for specific purposes.

**The Atmosphere:**

There is a diversity of atmospheres for meeting, collaboration, and concentrated work. Many different activities and target groups are located in different parts of the hall, each with a specific theme.



Level of Privacy

Low



Forum

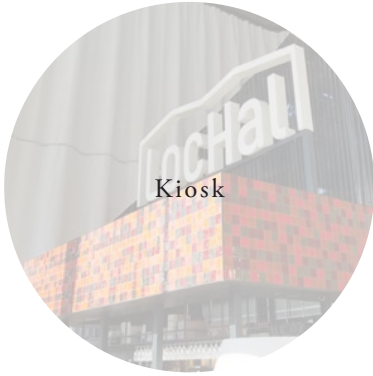

Kiosk



Concert Hall



Meeting Room



Study Room

High

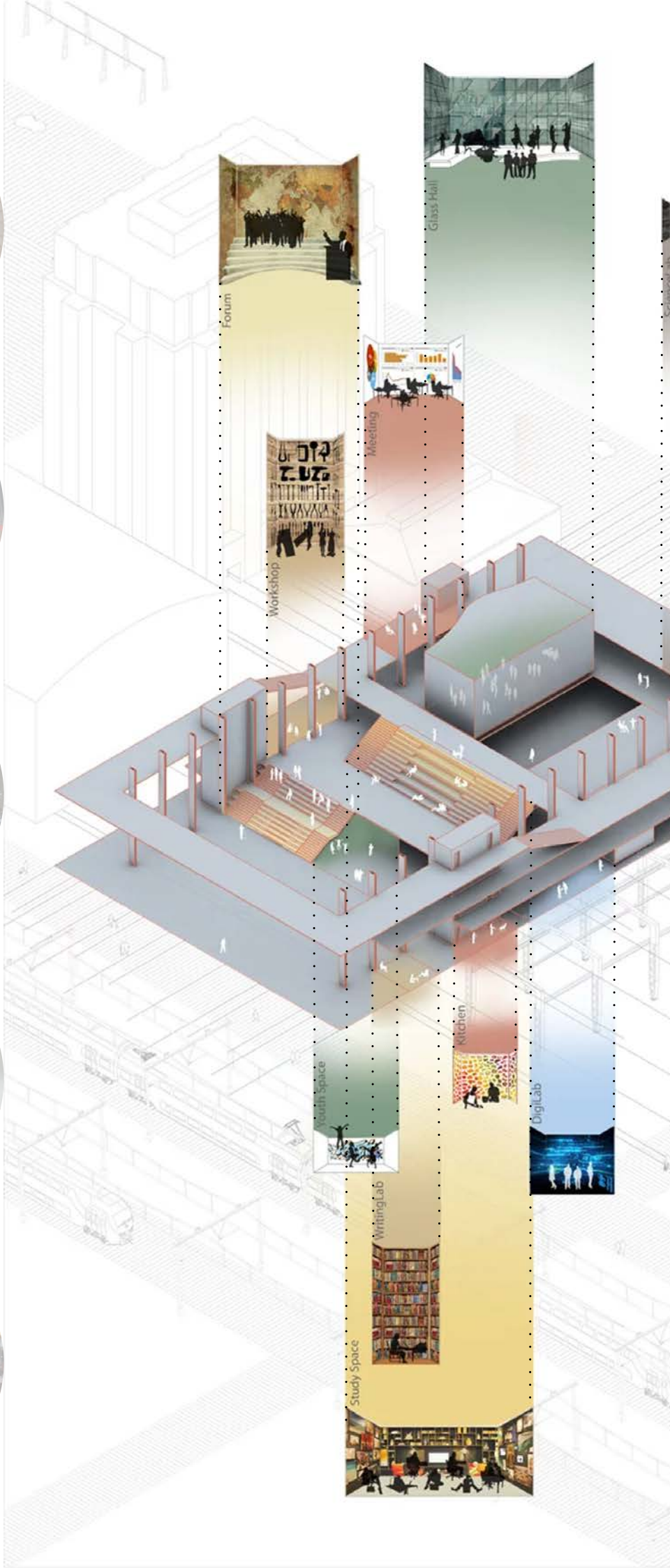



Specific Purposes

Screen Lab

Media & Audio



Mood Lab

Movie /  
Presentation



DigiLab

3D Printing /  
Coding



Word Lab

Writing



Youth Space

Playing

**Program - A new hybrid library for all**

The LocHal has redefined the function of a library in today's digital era. While there are the usual facilities for the traditional 'book consumer', the new library also provides ample opportunity for the creation of new knowledge. This can be done in the 'lab rooms' that spread across the building. One is in the form of a glass cube, formerly part of the concert hall in Amsterdam's Beurs van Berlage building. There is also the Food Lab, the Writing Lab, the DigiLab and the Screen Lab. Besides the lab rooms with specific purposes, the library area can be divided into different zones. Upon entering, the visitor enters a large central hall where he will get a unique impression of the former workshop. The entrance hall takes the form of a covered city square with large public reading tables, an exhibition area and a coffee kiosk. The square is followed by a series of stairs that provide space for seating, reading, working, discussing and performing. These steps lead up into the main building, notable for the huge glass facades which allow for plentiful daylight. On the second floor, the gallery and stairways allow closer inspection of the historic glass walls as visitors browse the bookcases or make use of the quiet reading areas. One floor higher is a large balcony offering panoramic views of the city.

*Left:  
The diversity of the programs create constant innovation*

*Photo source:  
<https://www.designboom.com/architecture/civic-architects-public-library-city-forum-netherlands-06-04-2017/>*



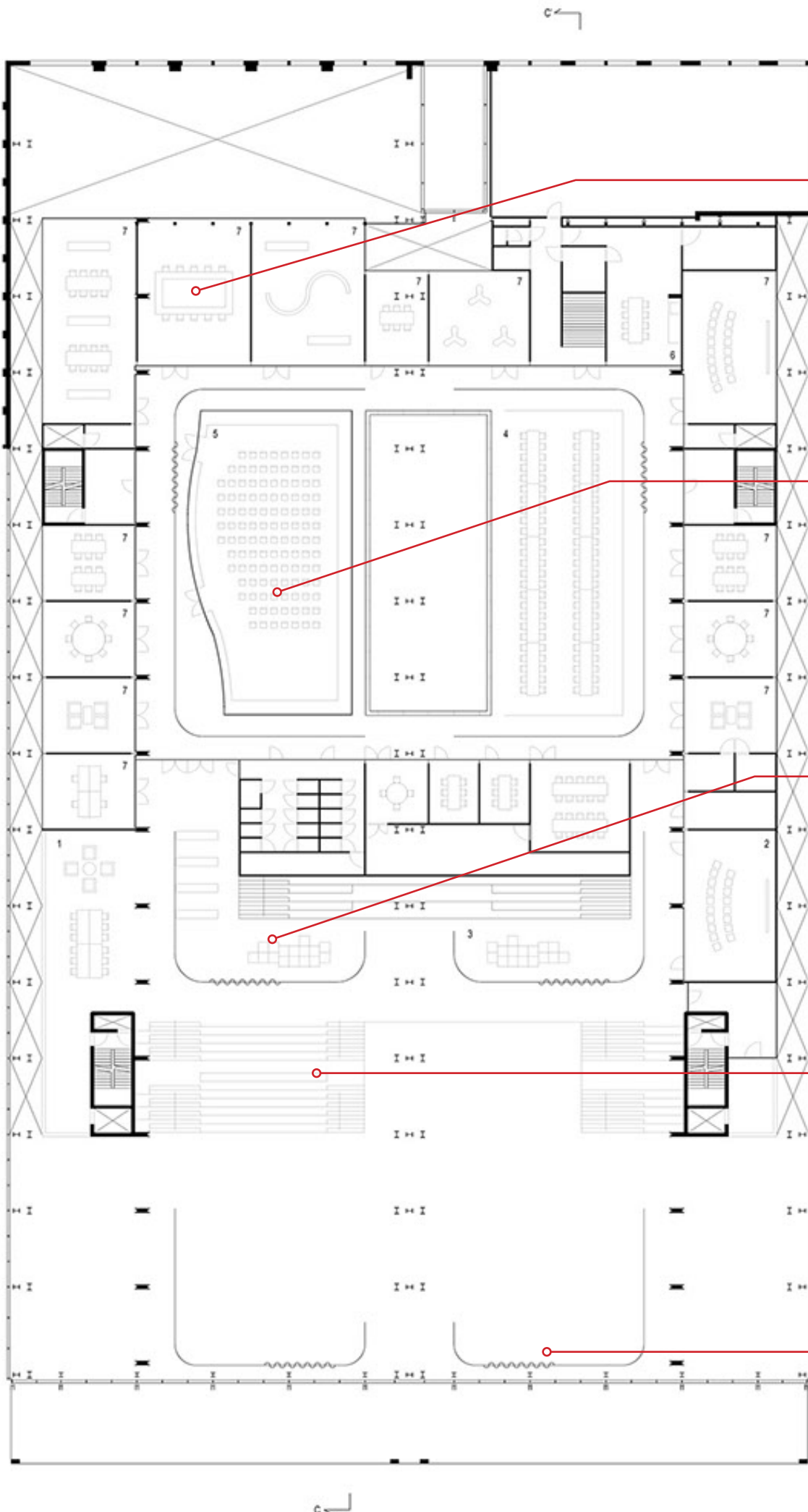

Writing Lab - Wood



Concert Hall - Glass



Seats - Books, wood, cushions

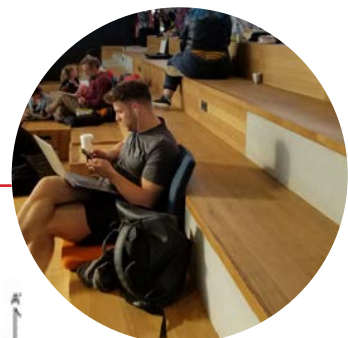

Stairs - Wood, concrete



Kiosk - ceramic tiles



### **Materiality - From a cold workshop to a cozy library**

Even though LocHal was constructed with rough and cold materials like concrete and steel, the intervention successfully transformed the industrial workshop into a cozy and warm place for people to stay.

Four materials are predominantly found in the LocHal: concrete, steel, wood (especially oak) and glass. A new floor is cast onto the existing concrete ground, and the current lubrication pits are covered with a crosscut wooden floor. The oak stairs and seating area with cushions compose a warm color palette of red and orange hues. The coffee kiosk is finished in red, brown and gold ceramic tiles. The glass facade and roof have been designed as a contemporary interpretation of the existing hall, providing the structure with the necessary softness and warmth for the light to enter from all areas.

*Left:*  
*First floor plan of LocHal*

*Photo source:*  
*<https://www.civicarchitects.eu/bibliotheek-tilburg.htm>*



Concrete paving

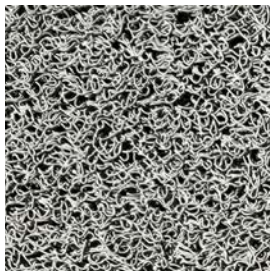

Plastic door mat



Stone door threshold



Carpet door mat



Fare face concrete

**Rough**  
**Outside**



**Fine**  
**Inside**

### **Transition - Entrance**

The new volume added next to the existing building demarcates the threshold of the library. The floor materials also indicate a transition from the exterior to interior space by using rough to fine finishes.

*Top:*

*The south facade with main entrance*

*Bottom:*

*Floor materials from the exterior to interior space*

*Photo source:*

*<https://www.archdaily.com/871894/construction-begins-on-project-to-transform-railway-hangar-into-a-mixed-use-library-in-the-netherlands>*

*Author's photos*



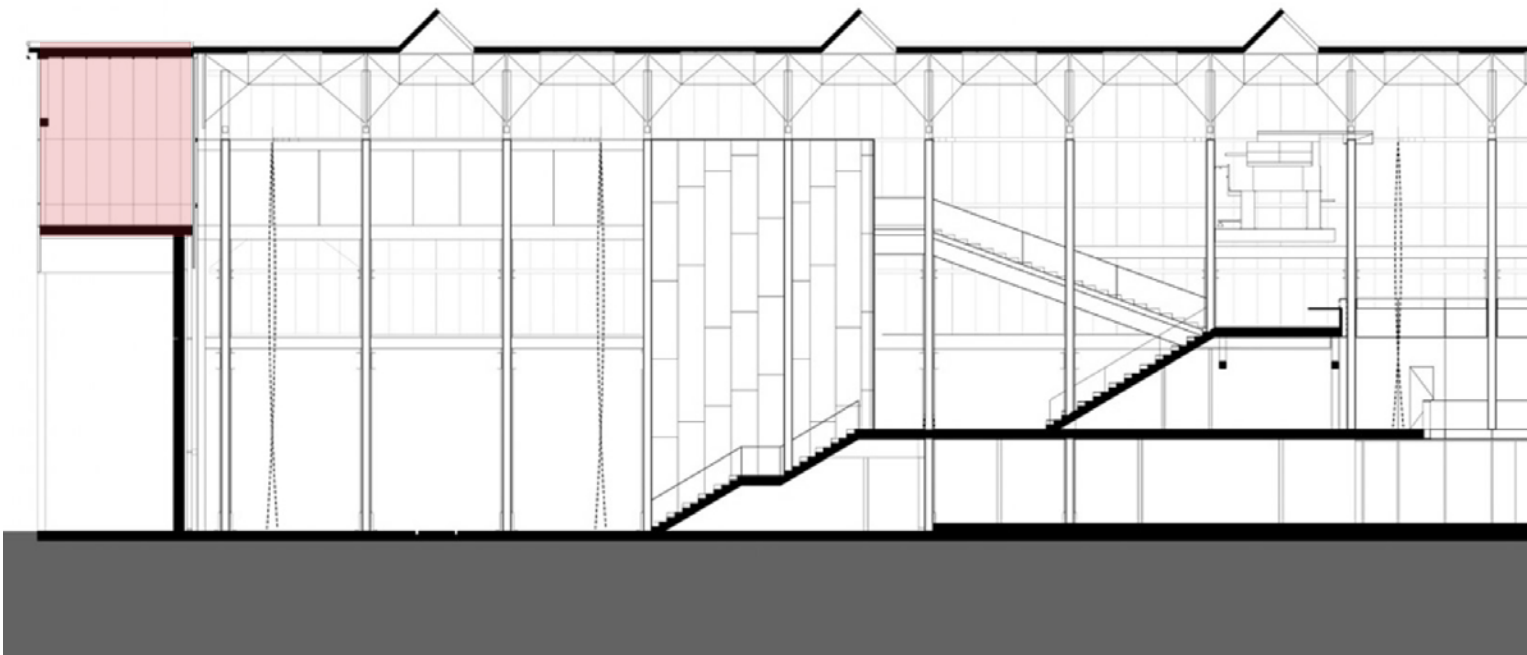

### Dialogue between old and new

The new architectural design is a contemporary reinterpretation of that of the original late-industrial building, dating from 1932, and builds upon the logic of that design. The glass curtain wall of the new winter garden follows the rhythm of the grid lines on the original facade. For the interior, the structure of the winter garden is painted as the same dark green color of the existing structure in the main space. The language between the new winter garden and the old mass seems to be coherent on the exterior facade, yet, the types of truss and roof bracing are different from the main hall when observed from the interior.

*Top:*  
*Exterior and interior of the winter garden*

*Bottom:*  
*Section C-C' of LocHal*

*Photo sources:*  
*Frans Parthesius, Lochal Tilburg,*  
*Album 2 / April -September 2018*

<https://www.civicarchitects.eu/bibliotheek-tilburg.htm>

*Author's photo*

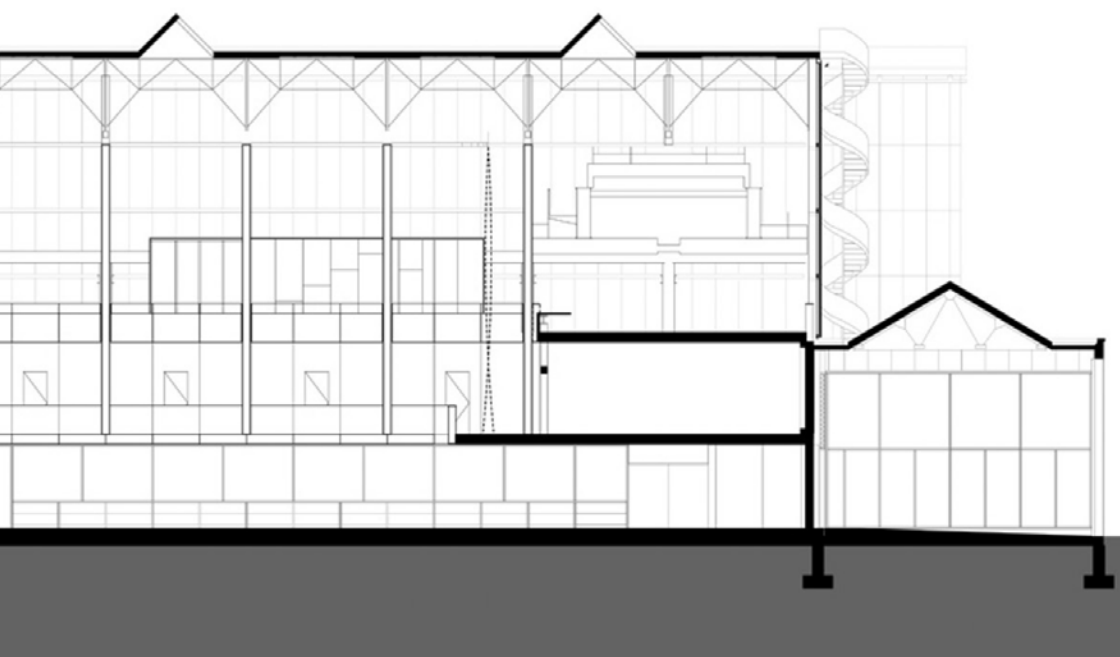



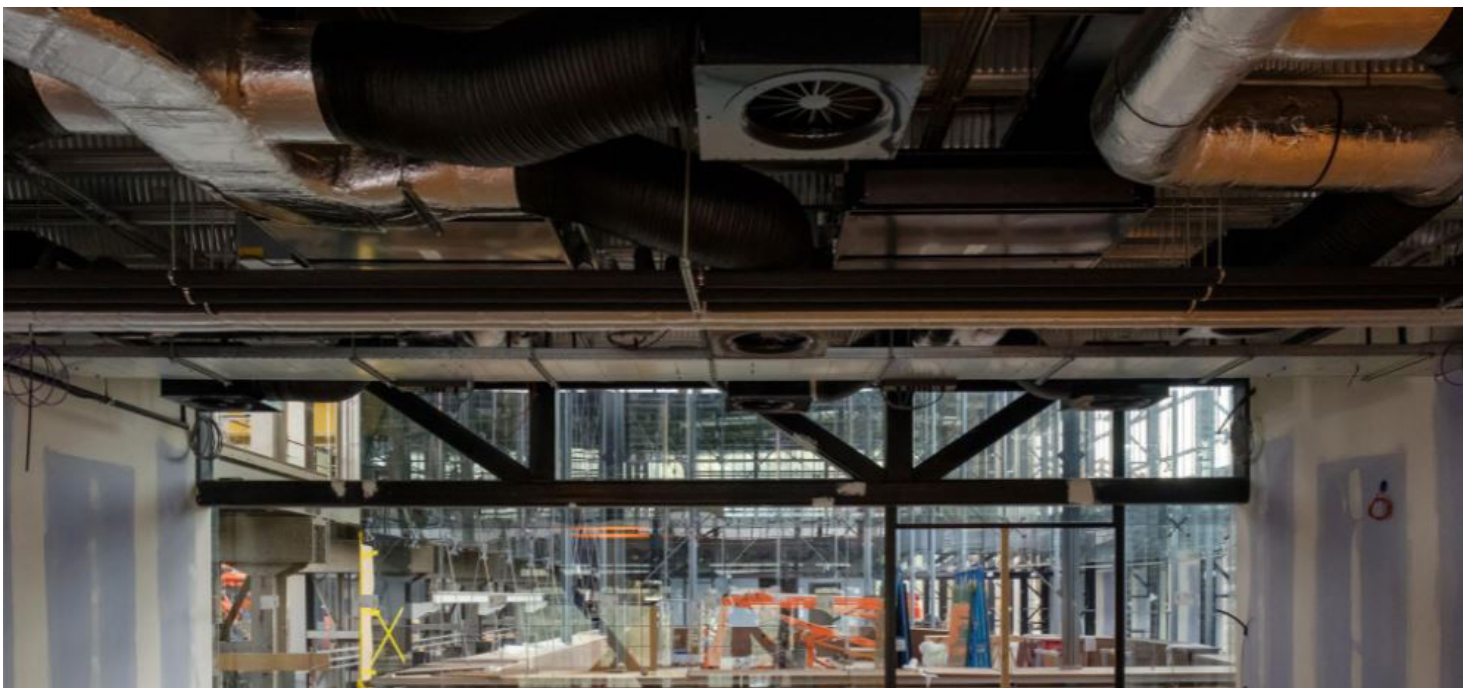



## Climate control

The building is locally and adaptively conditioned for mixed use. The open city hall has a climate concept tailored to its role of a roofed forum. Acoustic panels are installed above the forum for sound absorption. Seating on the stairs will be heated and cooled through ventilation grills while offices and labs will have their own sub-climate.

An ingenious system of five separate climate zones ensured that physical adaptations could be kept to a minimum. It was then possible to undertake the transformation of the enormous volume of the LocHal rather than the more radical intervention of replacing it.

*Top:*

*The acoustic panels installed above the forum area*

*Middle:*

*The landscape of the stairs can be heated or cooled, creating a comfortable interior climate*

*Bottom:*

*The ventilation system in office space*

*Photo sources:*

*Frans Parthesius, Lochal Tilburg, Album 2 / April -September 2018*

*Frans Parthesius, Lochal Tilburg, Album 3 / September - November 2018*

LEARNING FROM DE PONT





Project name: De Pont Museum of Contemporary Art  
 Location: Tilburg, Netherlands  
 Architects: Benthem Crouwel Architects  
 Built in: 1992 / 2016  
 Area: 1,100m<sup>2</sup>

### Introduction

The second building that we visited is the contemporary art museum, De Pont. The museum has been named after the attorney and businessman Jan de Pont (1915-1987) whose estate provided the means to establish a foundation 'for the stimulation of contemporary art.' Housed in a former wool-spinning mill, De Pont has been opened since September 1992. This building's transformation into a museum took place in collaboration with Benthem Crouwel Architects. The highlight of the factory is the large bright main hall - with on one side the intimate wool-storage rooms. In the hall are twelve skylights over the entire length of the building, which provide natural lighting and atmosphere in this unique space.

In 2016 the museum was expanded with a new wing which offers space for film, photography and video art, as well as for a café with a lounge and outdoor terrace.

*Photo Source:*  
*Author's photo*

*Source:*  
<http://benthemcrouwel.com/?s=de+pont#expansion-museum-de-pont-4121>



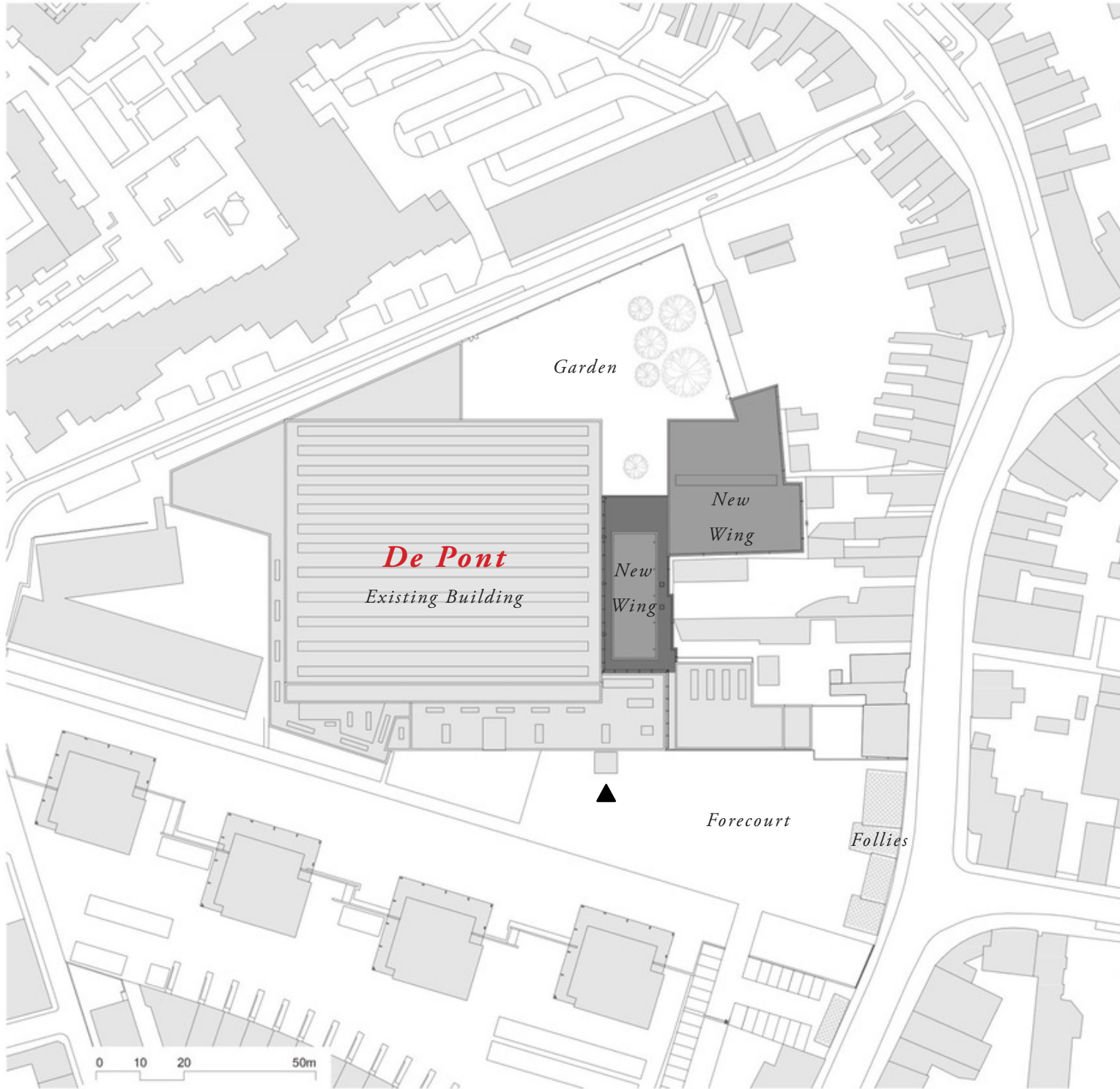

*De Pont*

*Existing Building*

*Garden*

*New Wing*

*New Wing*

*Forecourt*

*Follies*

0 10 20 50m



### Site Context - Entrance to the street

Already in 1990 the municipality of Tilburg commissioned an urban plan for this location, with the goal to create a worthy entrance to the street. The urban plan has been executed in phases and in 2016, a characteristic gate has been completed which will be explained in the following page.

*Photo Source:*  
<https://www.civicarchitects.eu/bibliotheek-tilburg.html>

*Source:*  
<http://benthemcrouwel.com/?s=de+pont#expansion-museum-de-pont-4121>



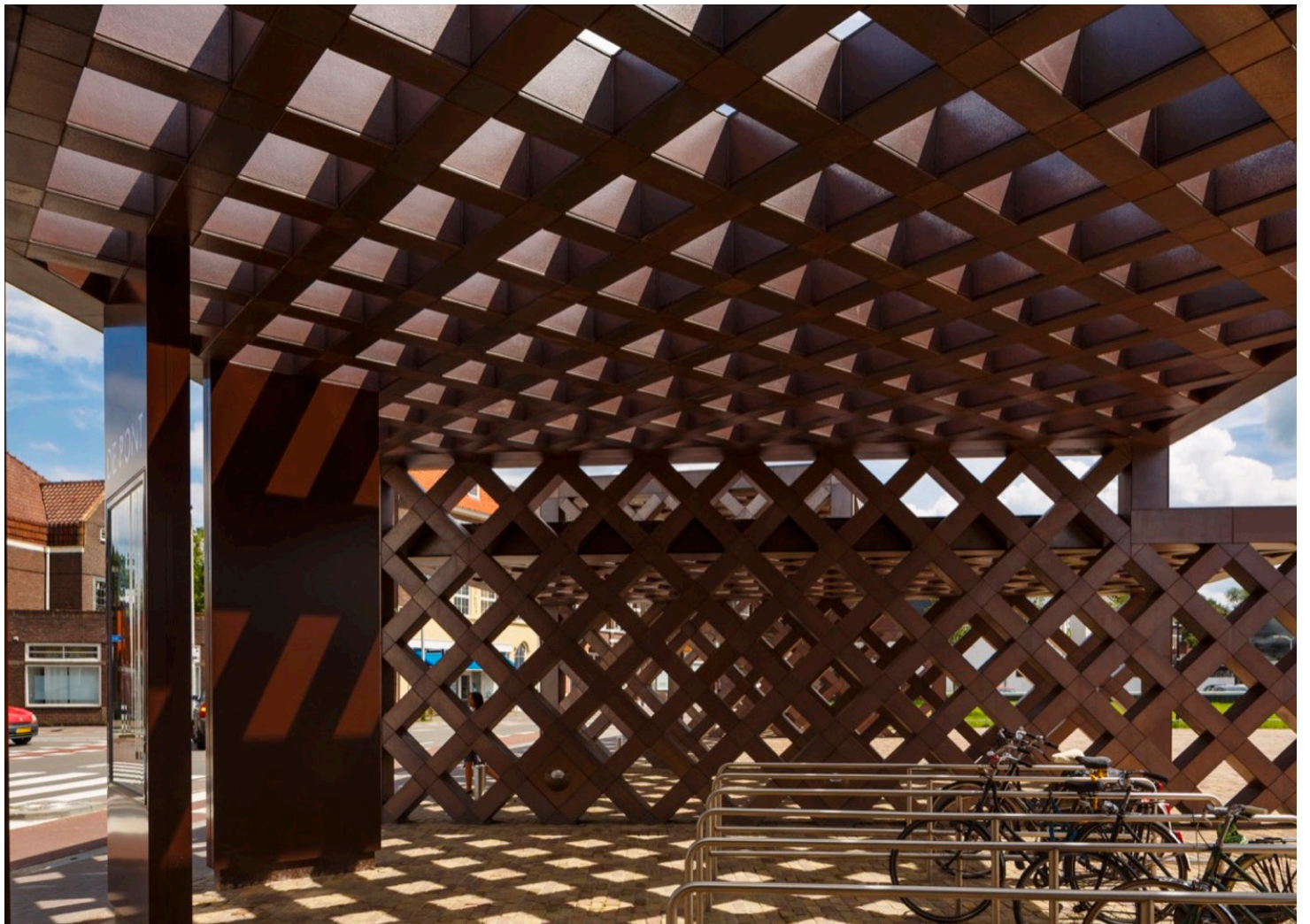



### Threshold - Demarcation of the museum area

The open steel interconnected passages, so called 'follies', demarcate the area of the museum. Visitors enter the forecourt of the museum through the new entrance gate. The gate is part of the adaptation of the entire forecourt and was donated to the museum for their 20th anniversary by the municipality of Tilburg. The five follies share the same design idiom. The height of the follies is related to its surroundings and is determined by its functions: driveway for buses and cars, entrance for pedestrians and a bicycle parking station. The passages are made of concrete, in a cut-away diagonal structure, and are coated with a ceramic material. This durable material has the same industrial look as the expanded metal facade of the museum. The contours of the gate are an interpretation of the original buildings around the museum. There is also a new layout for the car park, because of the increasing number of visitors. With the redesign, particularly the entrance gate, the original structure of the area is restored. Advertising facilities are integrated into the follies, as well as lighting, making the forecourt a pleasant area at night.

*Top:*  
*The follies*

*Bottom:*  
*One of the follies is a bicycle parking station*

*Photo source:*  
*<https://www.archdaily.com/795700/museum-de-pont-expansion-and-new-entrance-gate-benthem-crouwel-architects>*

*Source:*  
*<http://benthemcrouwel.com/?s=de+pont#expansion-museum-de-pont-4121>*

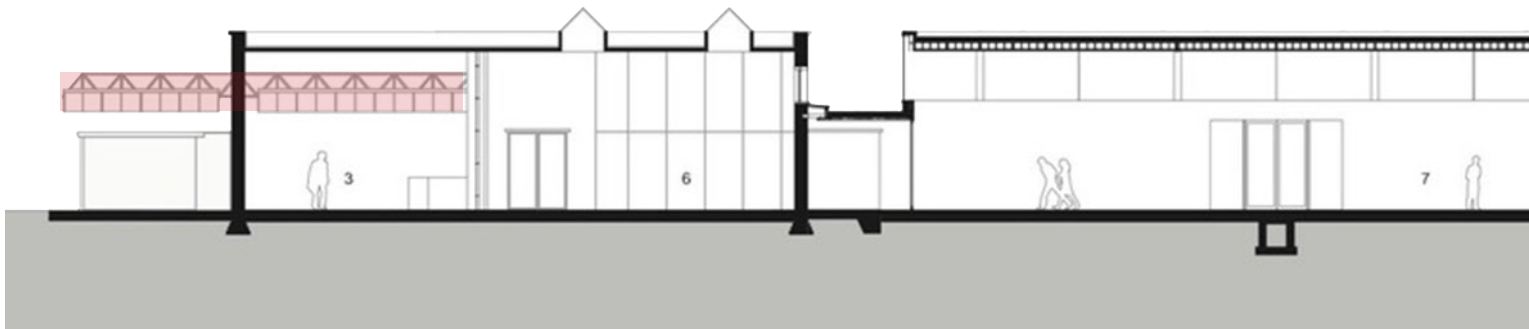

A metal round cylinder with a rotating door is added along the long south facade to indicate the entrance of the museum. The steel space frame structure which holds the folded roof, intrudes into the interior of the entrance area. It creates a spatial continuation from the outdoor to the indoor environment.

*Photos source:  
Author's photos*

*Section source:  
<https://www.archdaily.com/795700/museum-de-pont-expansion-and-new-entrance-gate-benthem-crouwel-architects>*

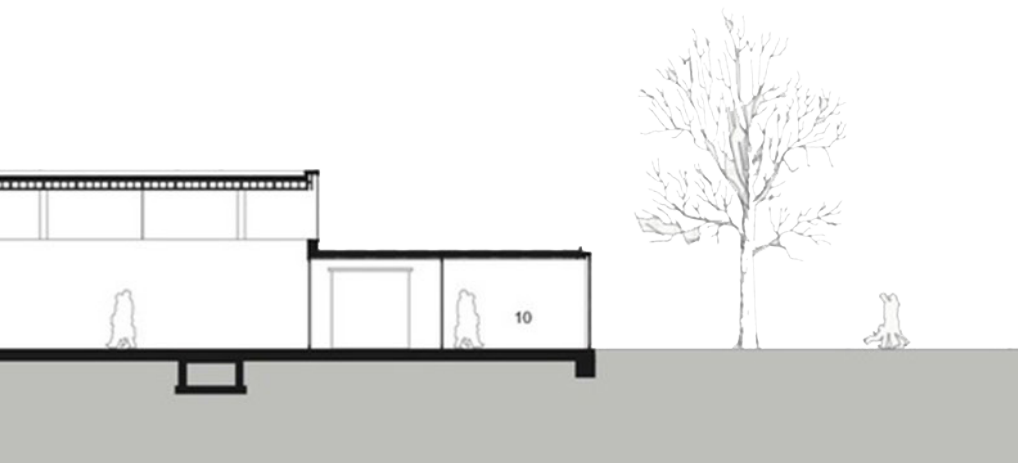



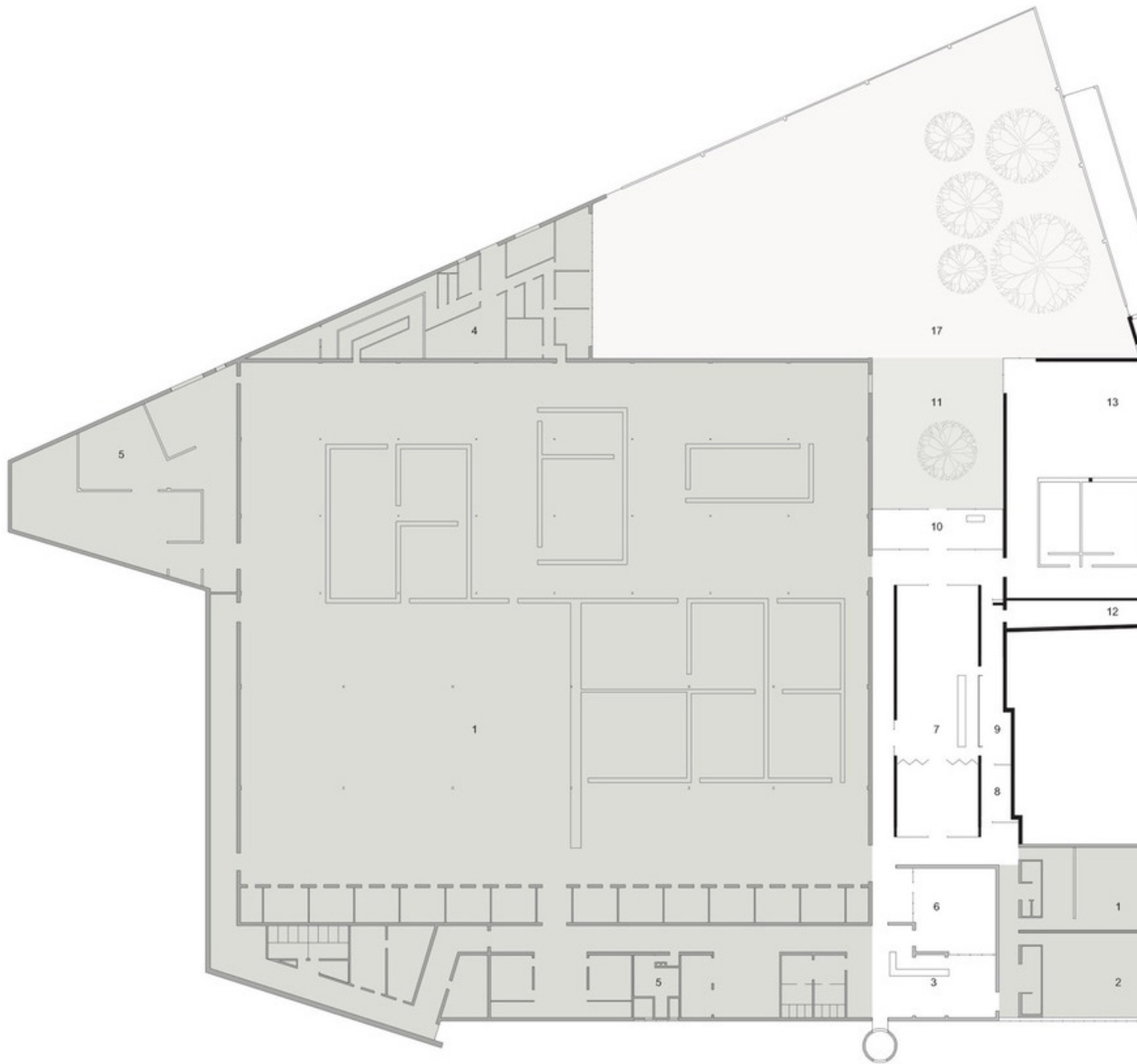

*Existing*



*Terrace*



*Garden / Patio*



*New Wing*

1. existing exhibition hall
2. existing auditorium
3. entrance area/museum shop
4. offices
5. existing depot
6. library
7. restaurant
8. storage
9. restaurant kitchen
10. lounge
11. terrace
12. technical room
13. new exhibition hall
14. new depot/storage
15. transit deposit
16. loading/unloading area
17. museum garden
18. patio
19. studio house

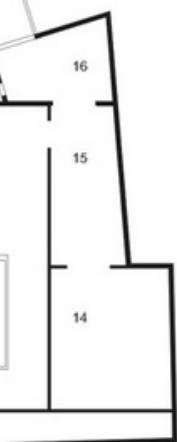

0 5 10 25m



### Program - Logical sequence of functions

The new wing of the museum is adjacent to the museum garden and hosts mainly film, photography and video art. The exhibition space is 20 by 27 meters, in total almost 600m<sup>2</sup>. The new hall provides additional exhibition opportunities for the growing collection of the museum. The new restaurant has an adjoining lounge - including a fireplace in the lounge area, which connects beautifully to the museum garden. The restaurant has been enlarged and has a central location between the old building and the new wing. The characteristic line of sight along the original outer wall of the museum remains intact and is well adapted to the current museum route. Because of top windows, which make the spaces spectacularly bright, the ceiling almost seems to levitate. The museum shop is enlarged and is connected to the library. The recent adjustments create a much more logical sequence of public functions: entrance hall, bookstore, library, restaurant, lounge with terrace and museum garden.

Source:  
<http://benthecrouwel.com/?s=de+pont#expansion-museum-de-pont-4121>

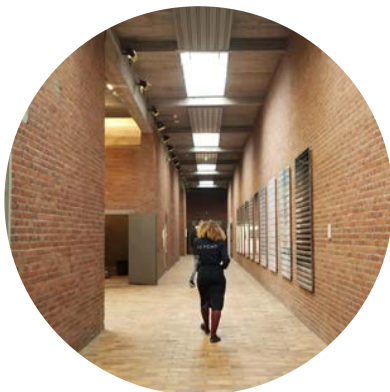
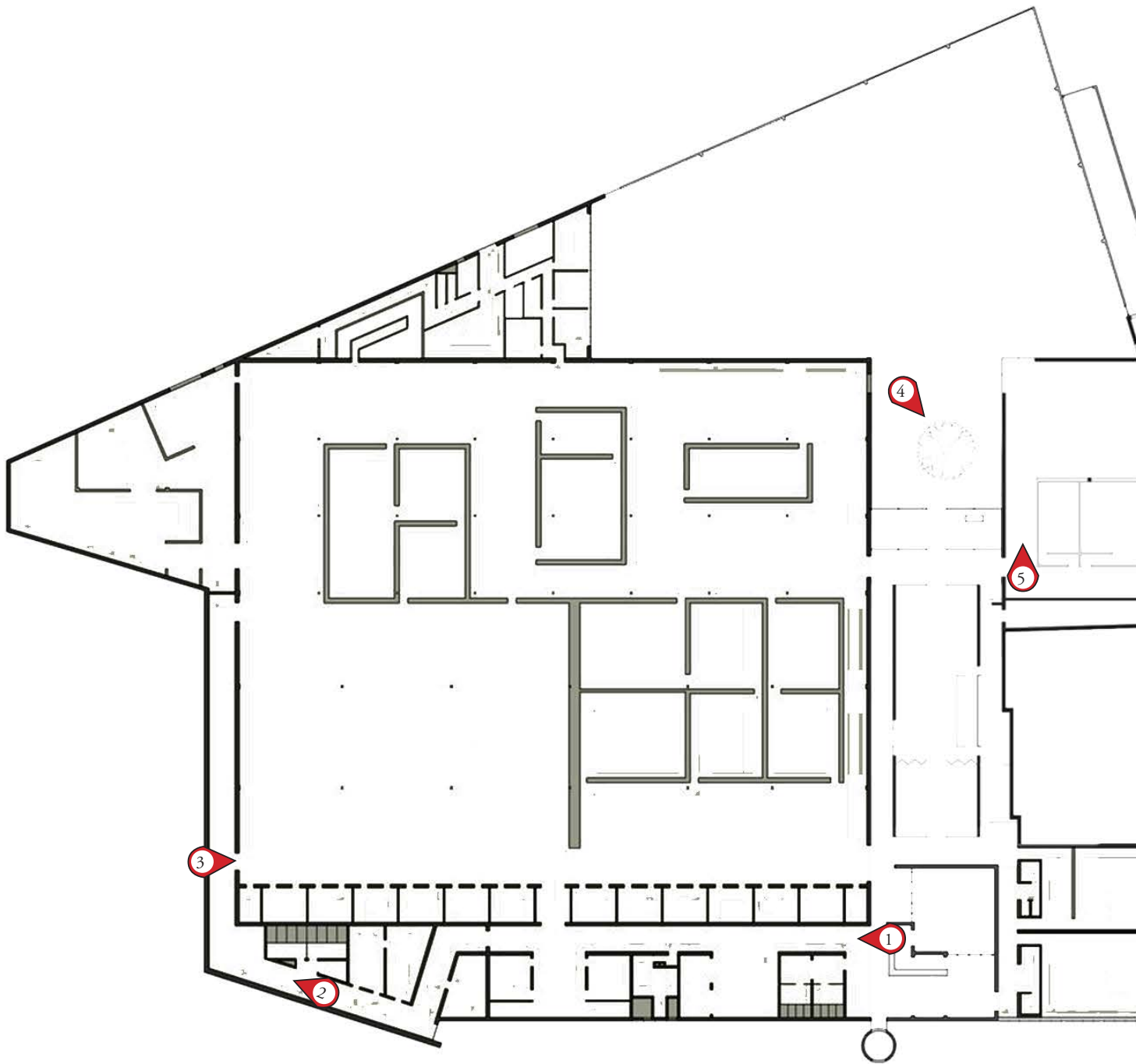



### Transition - Building up sense of anticipation

*“In most art galleries, you have a sense of what to expect when you enter, since the halls are symmetrical and the route is predictable. In contrast, at Museum de Pont, visitors enter the foyer and are faced with a softly-lit 60 metre corridor ahead of them, ending in a garden. What kind of rooms lead off this corridor is unclear. There is a sense of anticipation, a sense of excitement. What surprises lie in wait? That was the emotion I hoped to elicit when I designed the corridor, making a completely new opening in an exterior wall to do so. Even when the museum renovates or changes exhibitions, the long corridor remains: it’s a vital element for us.”*

*- Benthem Crowel Architects*

During the visit, we followed the exhibition route. We were surprised at the end of the corridor which opened up to the main exhibition area with a sudden change of spatial perception, from a long narrow corridor space to an expansive unobstructed space.

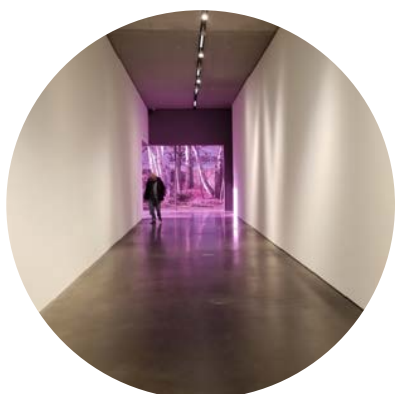
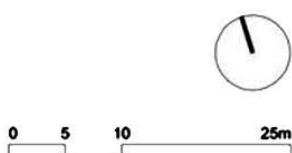
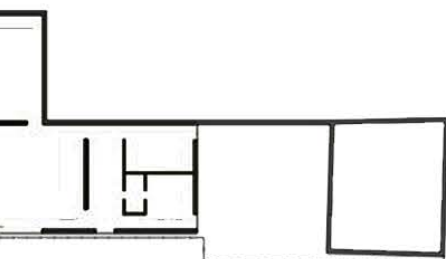

Source:  
<http://benthemcrowel.com/?s=de+pont#expansion-museum-de-pont-4121>

Author's photos

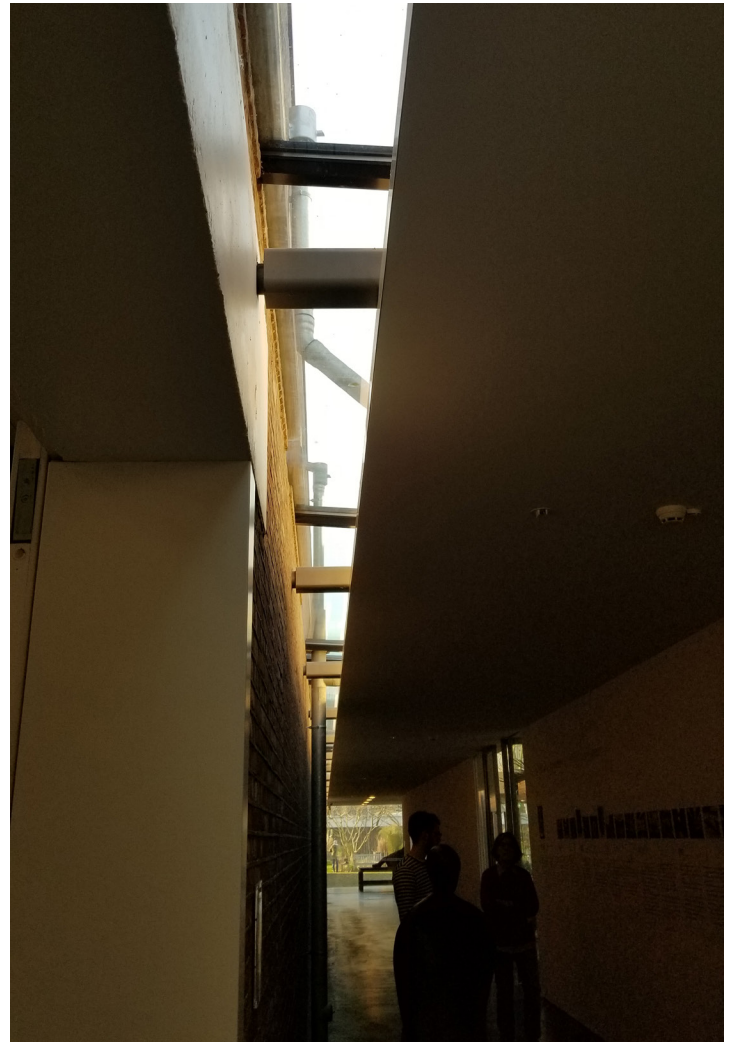

### Dialogue between old and new

The new café has been given a central location between the old building and the new wing. The characteristic line of sight along the original exterior wall of the museum toward the garden has remained intact. Upper windows around the space cause the ceiling to ‘float’ and make the café a spectacularly light space. As an extension of the café, a lounge forms the transition into the patio and garden. By way of a wide corridor situated between the lounge and the restaurant, visitors can walk from the old building into the new wing.

The new wing is attached to the original building with a slit of skylight in between. The intervention makes a clear division of the old and the new. In my opinion, the connection detail can be done more subtly and elegantly by using thinner structural support.

*Top:*

*Line of sight along the original exterior wall of the museum toward the garden was remained.*

*Bottom:*

*The connection and the lighting condition between the old building and new wing.*

*Photo sources:*

*<https://www.archdaily.com/795700/museum-de-pont-expansion-and-new-entrance-gate-bentham-crouwel-architects>*

*Author's photos*



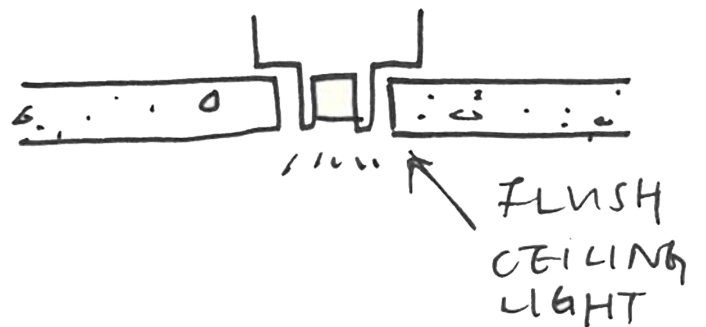
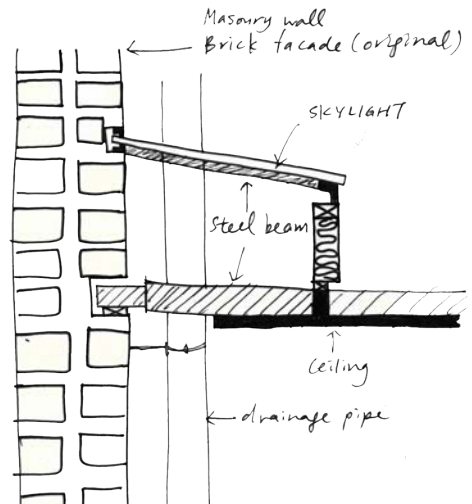
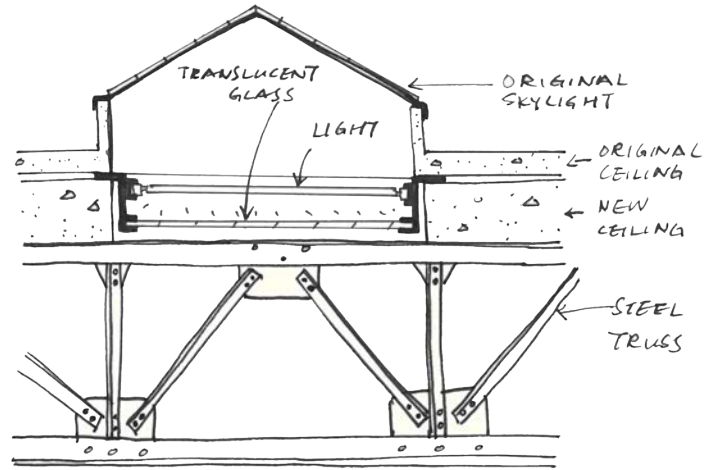
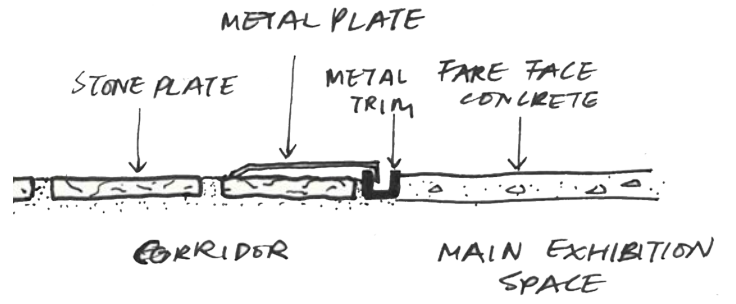

### 1. Transition of space

The transition of long corridor and the main exhibition space is expressed by the flooring material. The corridor is paved with brick while the exhibition space has a fare face concrete floor finish. The connection is covered by a metal plate with a gap in between.

*Photos source:  
Author's photos*

*Sketches:  
Author's illustration*

### 2. Diffuse daylight

Since most of the artworks cannot be exposed to direct daylight, translucent glass is installed underneath the twelve original skylights. It creates diffuse daylight for the exhibition space.

### 3. Connection between old building and new wing

The new wing is attached to the original building with a slit of skylight in between. The steel beams intrude into the existing exterior wall to support the ceiling and skylight of the new wing.

### 4. Hidden detail

The lighting fixture is flushed with the ceiling. Visitors can focus on the exhibition space without noticing the hanging lights or messing wiring.

# FRAGMENT WORKSHOP



The workshop this week aims at focusing on one fragment of the selected building in order to study the spatial quality, the ceiling/wall/floor connections, the materiality and the detailing. I have chosen the ammunition factory which will be transformed into a library with exhibition space. After drawing the sectional perspective above, I realized the depth of space is currently quite dull and flat. The spatial quality can be enriched by



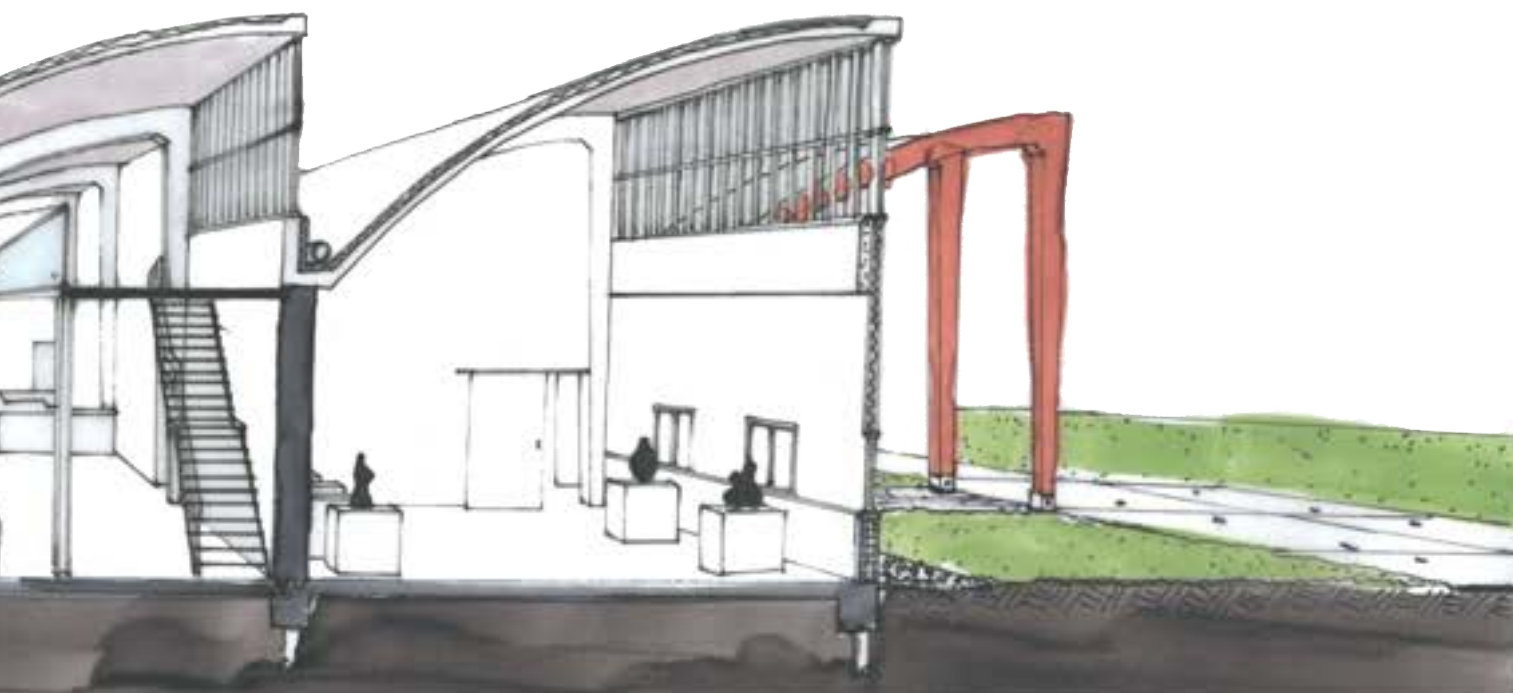

creating partitions and mezzanines. Learning from the LocHal library, I also recognized that it is very crucial to provide various zones for specific purposes and different target groups for this kind of new hybrid library.



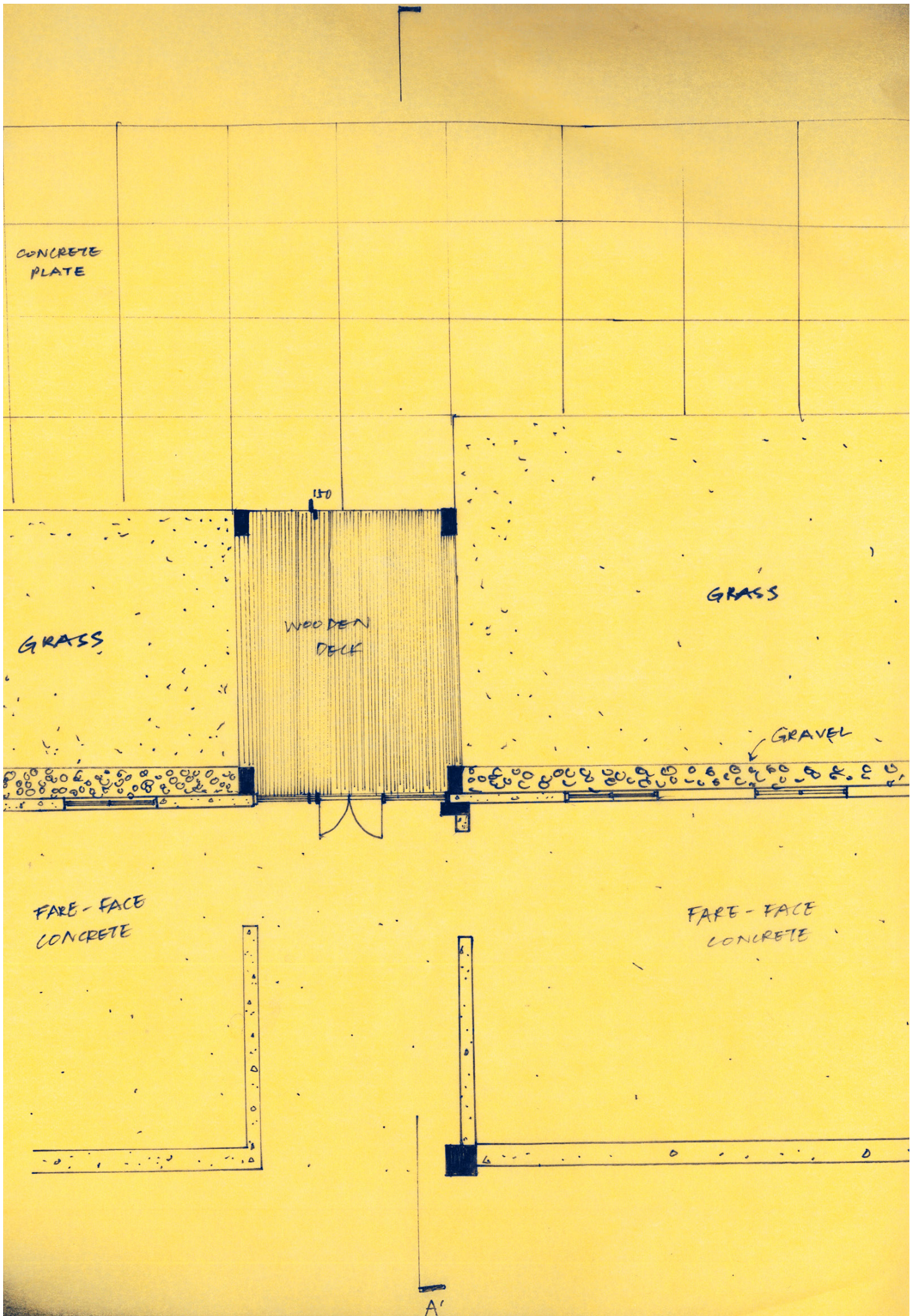



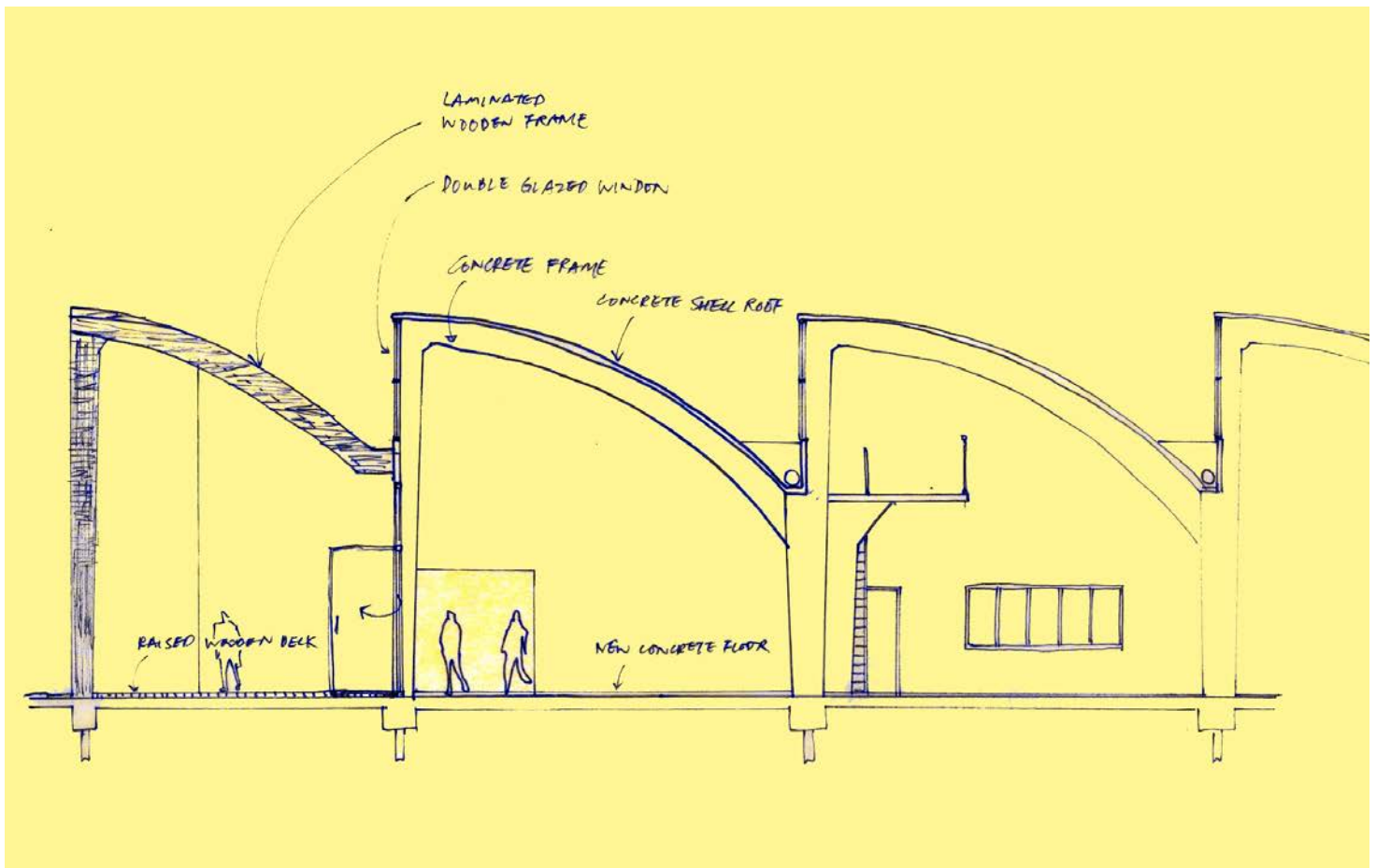

### Transition - Entrance

There are many doors in the existing factory. It is not clear that which the main entrance is. In order to make a gesture for the entrance, I have extracted the main structural element - the curved portal frame and replicated it with new contrasting material, wood as a threshold. The floor materials also suggest the transition from the exterior to the interior indicated by rough to fine surfaces.



IN

NEW CONCRETE FLOOR

ORIGINAL  
CONCRETE  
FLOOR

WATER PROOFING

DRAINAGE BOARD

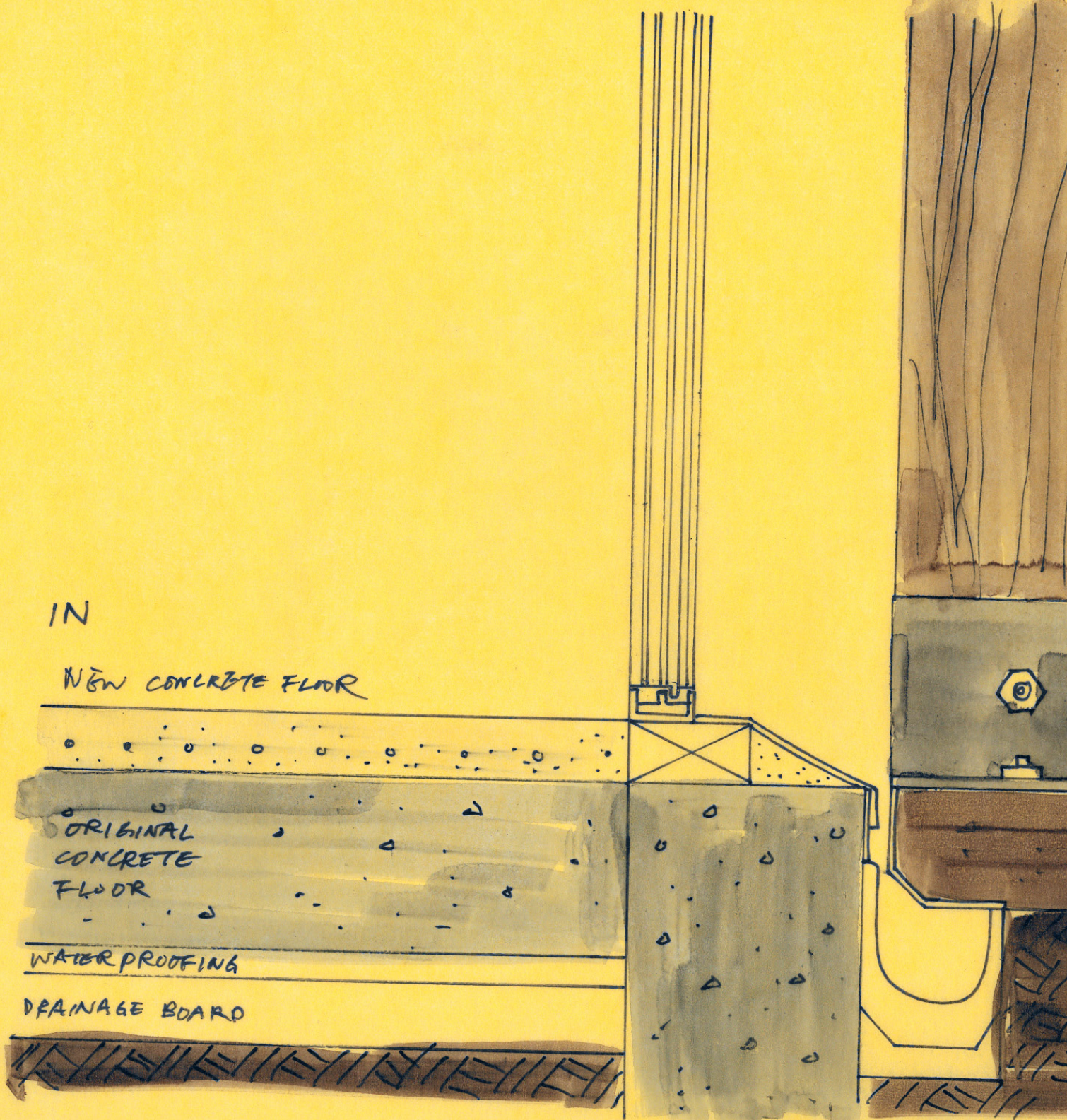





### Floor detail

The 1:5 floor detail exercise gave us an idea of the material thickness and the detailing. The left drawing shows the main entrance floor detail. There is a gutter separating the outdoor wooden deck and the indoor space to avoid influx of rain water. I want to have an unnoticeable gap, therefore, I used the gutter with a narrow metal trim detailing.



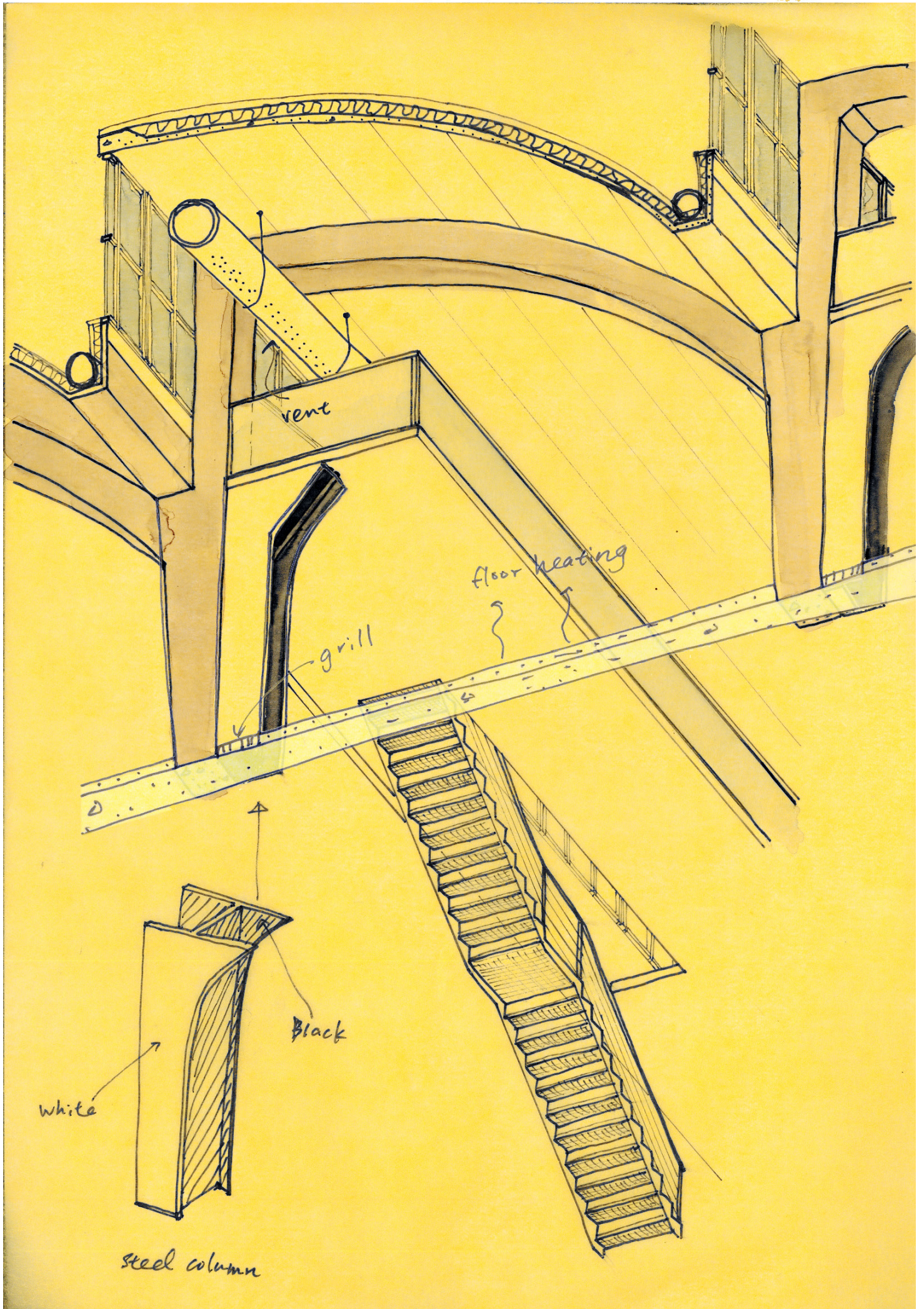

vent

floor heating

grill

white

Black

steel column



### Ceiling / Wall / Floor Connection

From this fragment exercise, I paid more attention to the connection between the ceiling, wall and floor. Below are some remarks and unsolved questions.

The Ceiling:

- Insulated from outside
- Additional ventilation
- Attic space lit up by northern light
- ? Cold bridge between ceiling and wall insulation
- ? Connection of ventilation system and ceiling

The Wall:

- Insulated from inside
- New column to support mezzanine
- ? Form of the new column
- ? Material of the new column

The Floor:

- Pour new floor on top of existing floor
- Fresh air from the grill
- ? Connection between columns and new floor

*Left:*

*Axometric of a fragment within the ammunition factory showing the connection of ceiling, wall and floor*

*Bottom:*

*Axometric of the new column to support the mezzanine*

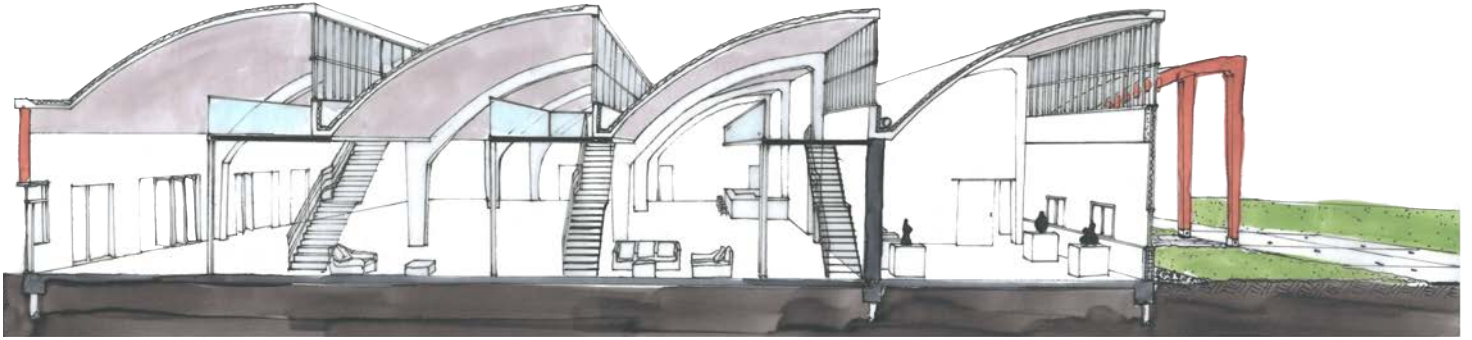

Sequence of space

Zoning

Level of privacy

# Spatial Quality

Layer of space

Level of daylight

Depth of space

Layer of space

## DEPTH OF SPACE

After the fragment workshop, I have reflected on my current design. I realized that the spatial quality of the ammunition factory is currently lack of depth. Learning from the LocHal, I have come to an understanding that the complexity of space can be evaluated by the layers of space and the interaction between different programs. Therefore, I have tried to create different area/zones, each has their specific functions and target groups. It can be seen in the following plan and sections.





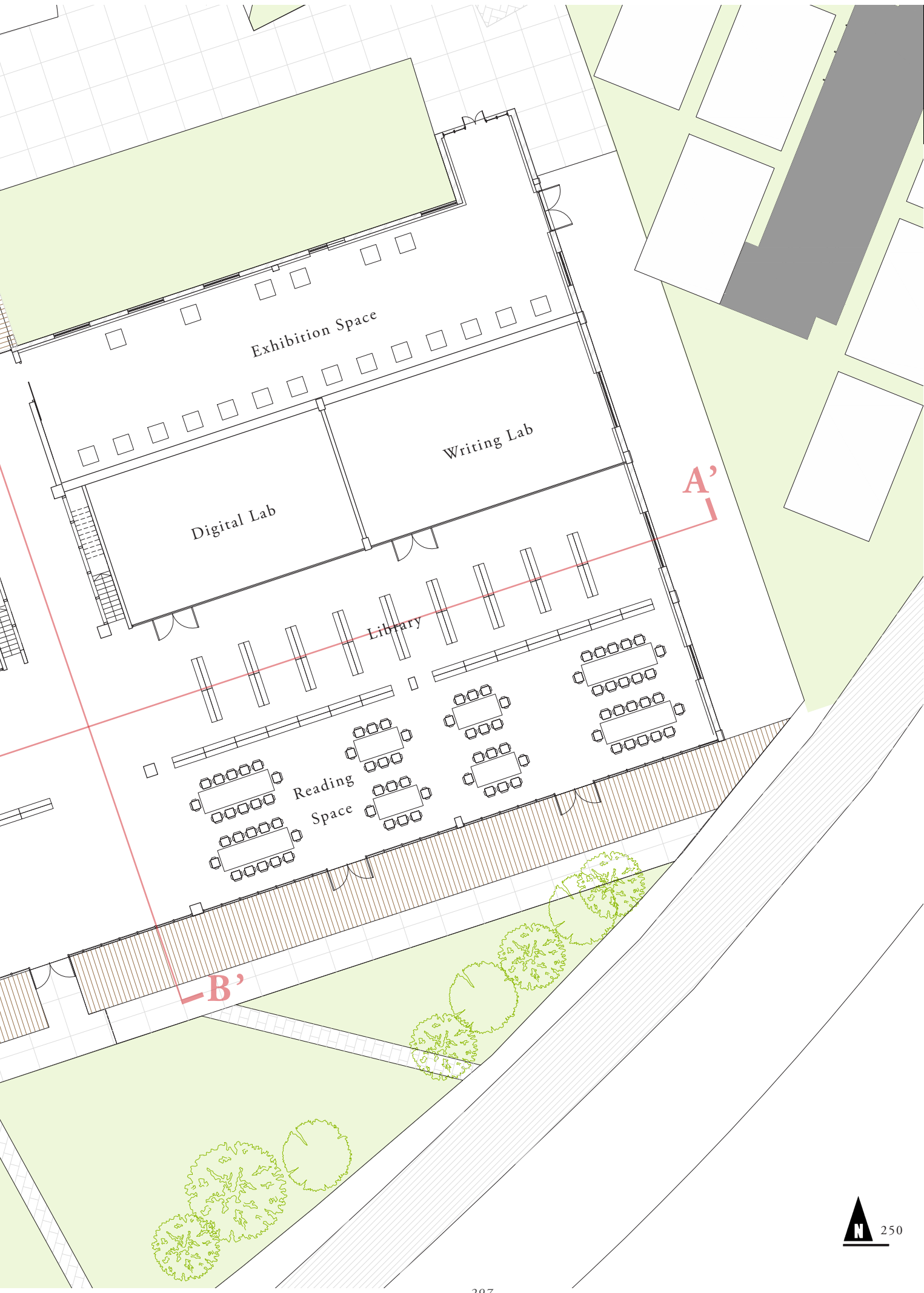

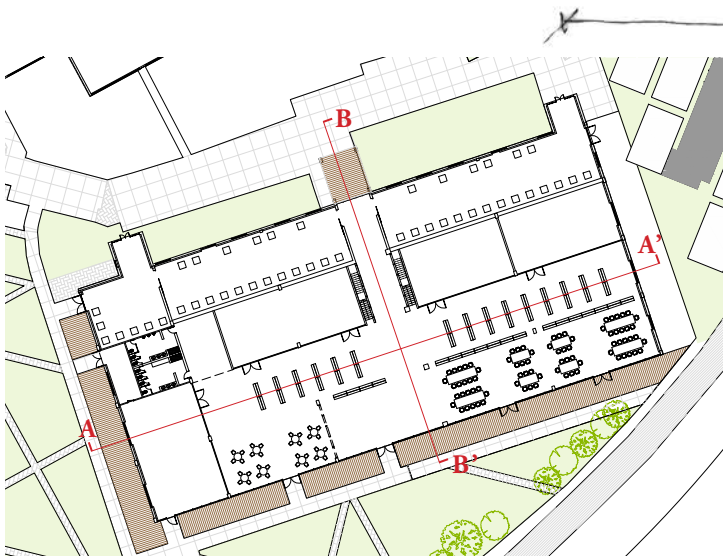
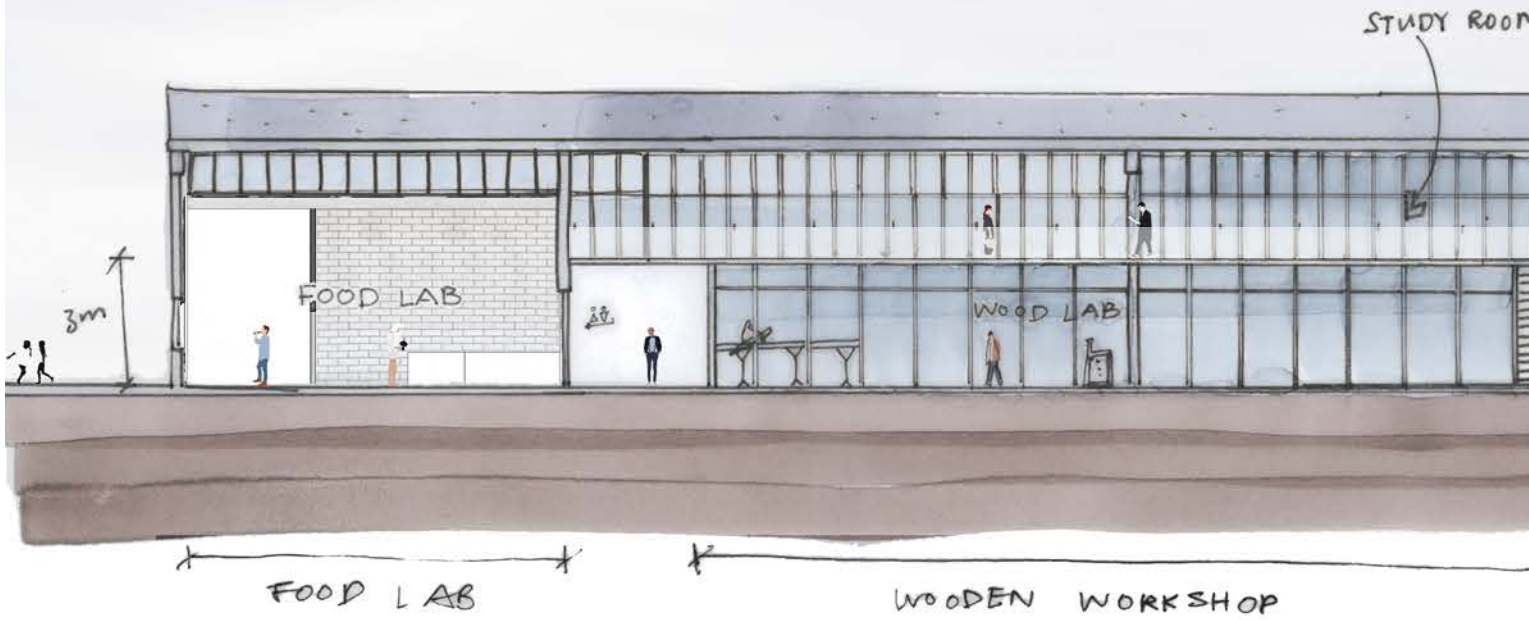

STUDY ROOMS x 12  
(A B O V E)  
2 x 2 m each



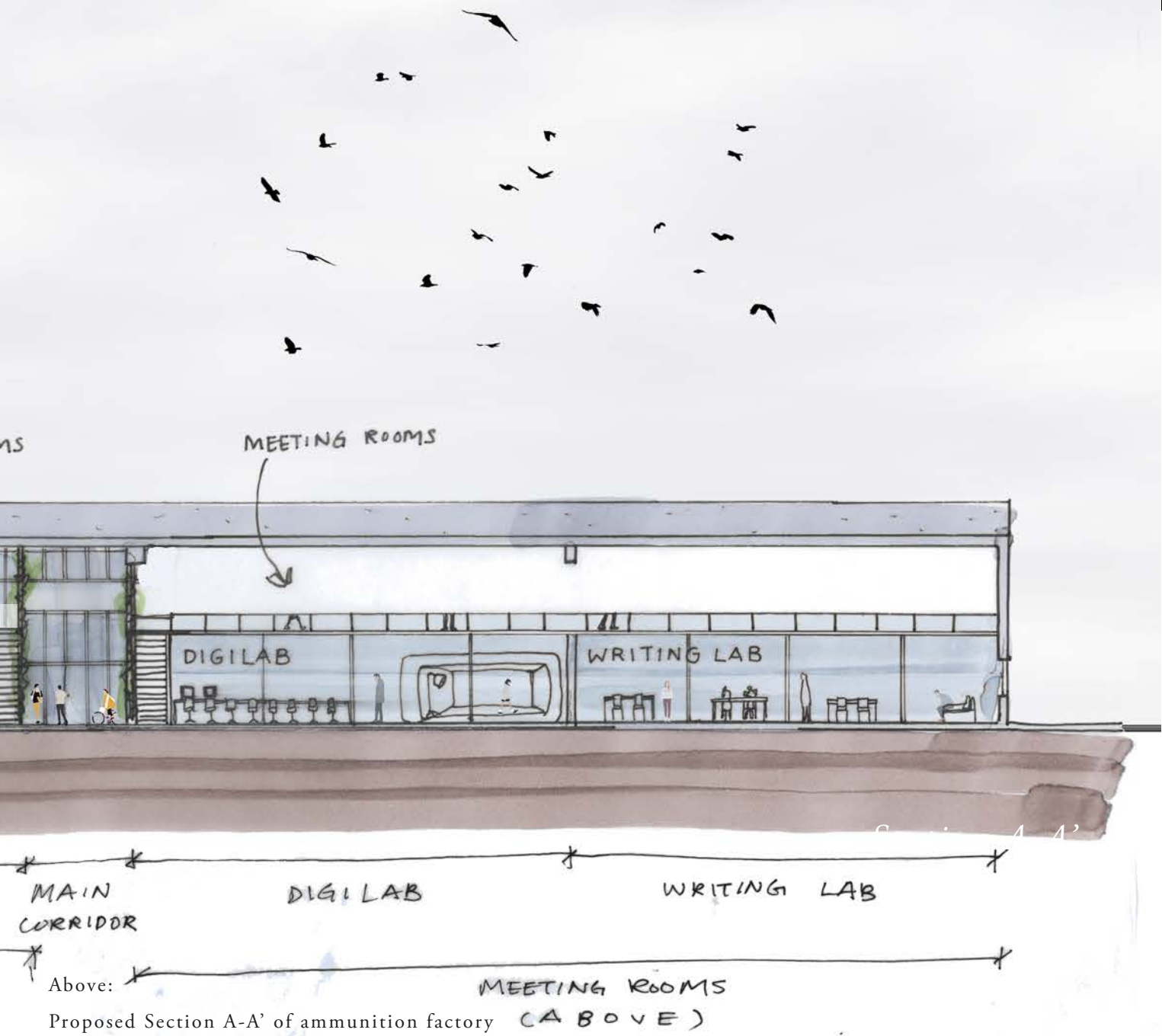

Above: Proposed Section A-A' of ammunition factory (A B O V E)



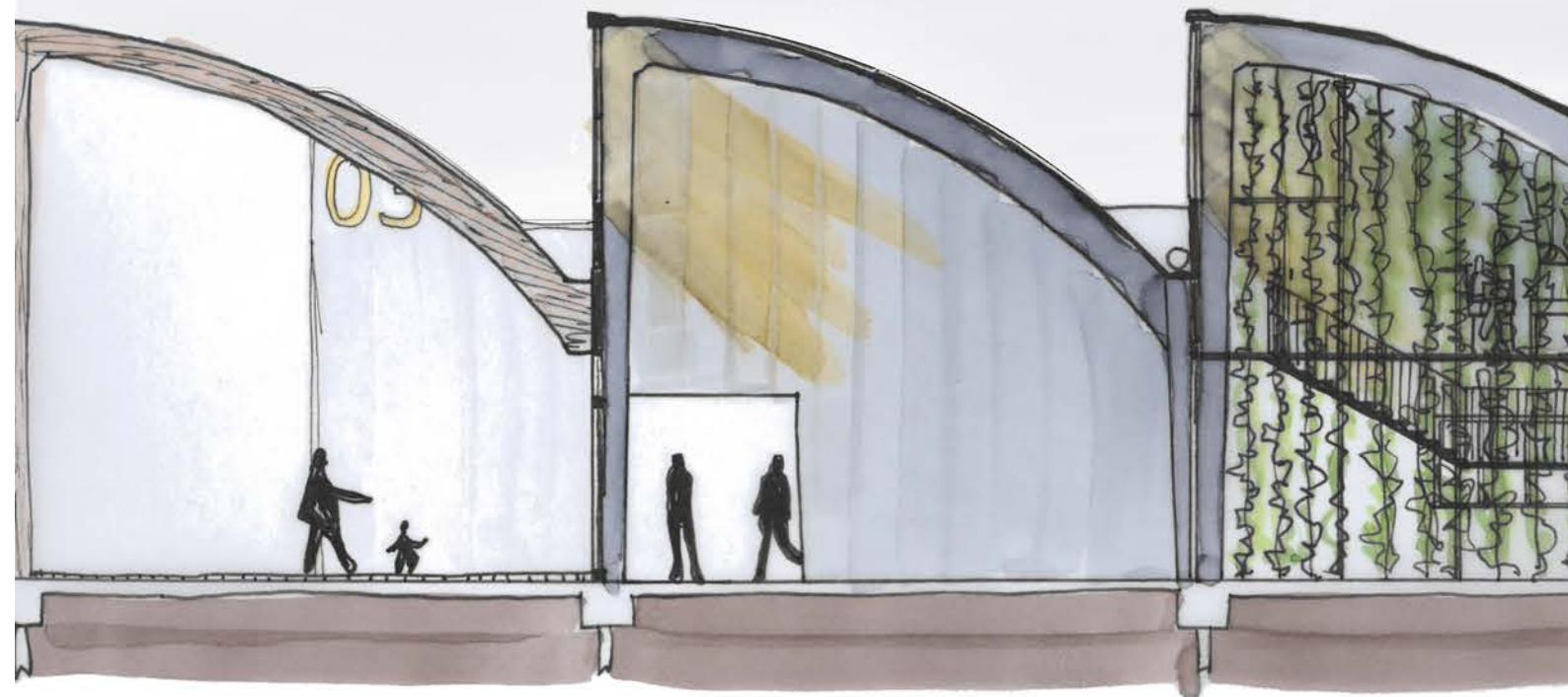

ENTRANCE

EXHIBITION

MEETING LABS

LABS

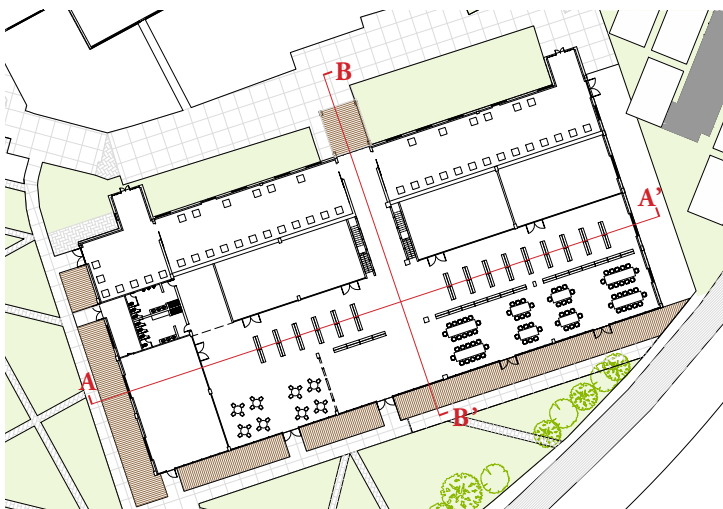

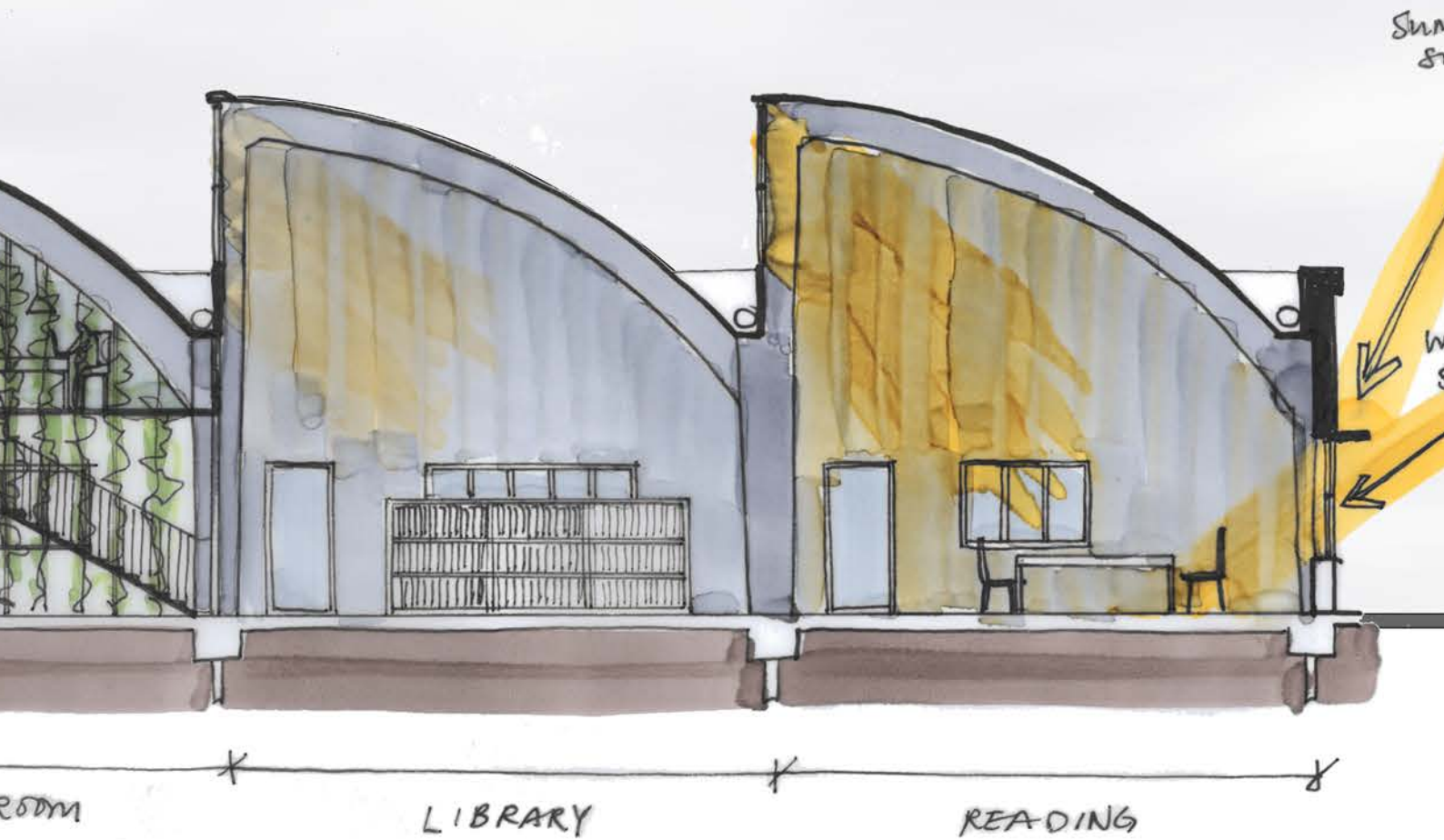

Above:  
Proposed Section A-A' of ammunition factory









ORIGINAL



HYBRID



BRICK + GLASS



GLASS

In the current design, I have arranged the program according to the need of daylight. Programs that require more daylight are located near the south facade. In order to capture more light, I replaced the original masonry wall to translucent or transparent materials, for instance glass. In the facade study on the left, I was testing the combination and proportion of solid and transparent materials.



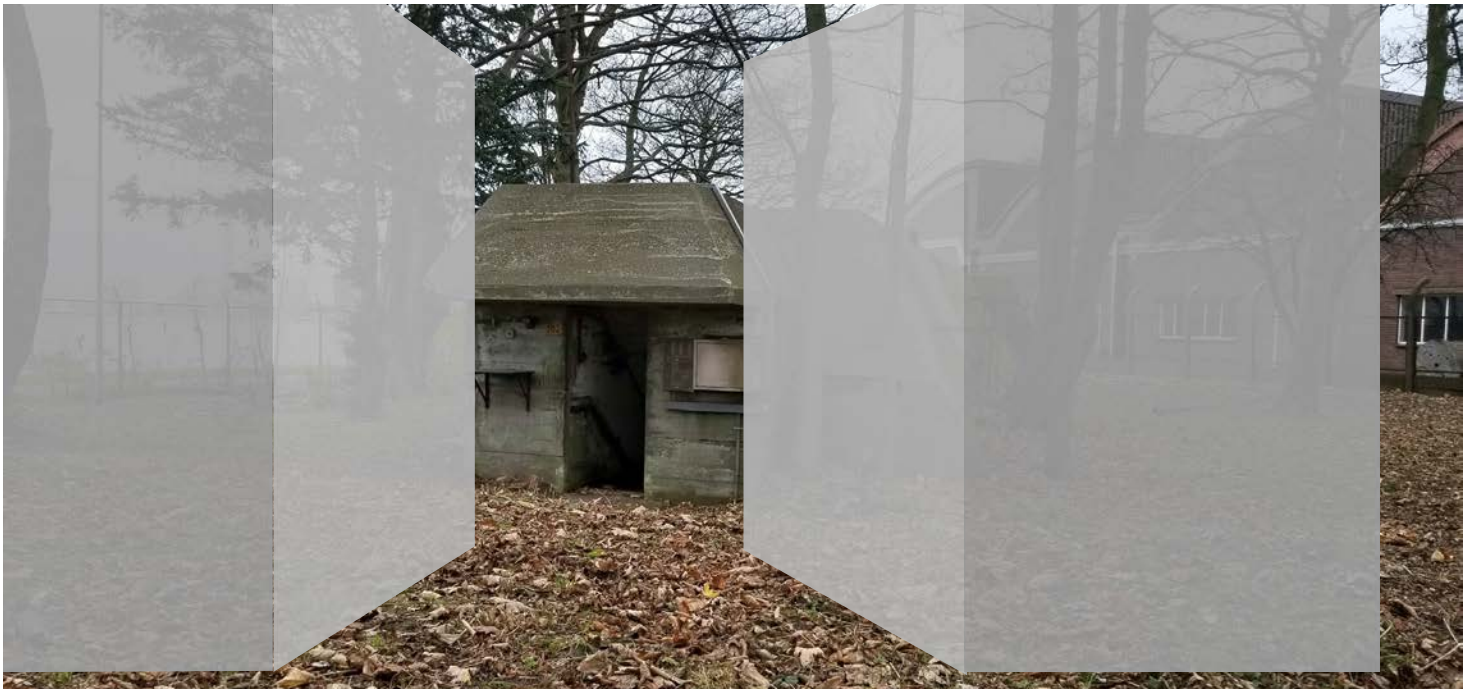



## THOUGHTS ABOUT THE BUNKER

Reflecting on the comment in P2 presentation, I want to capture the spatial quality of the commander bunker and exaggerate it to the ground level, so that people can have a 'preview' of the narrow underground tunnel in the bunker. From the left, you can see that I was using big concrete blocks to create narrow corridor space.

*Left:  
Testing to formulate narrow corridor  
space by arranging big concrete blocks.*

# LANDSCAPE DESIGN REFERENCE



Right through the middle of the Technical University of Delft (TU Delft), the 800 meters long and 80 meters wide Mekelweg was transformed into an attractive park for the school community. The park unifies and adds allure to the university by connecting different faculty buildings with a zigzag walkway amidst the green. Inspired by the park, I applied the idea into my landscape design. The four urban grids govern the orientation of the path.





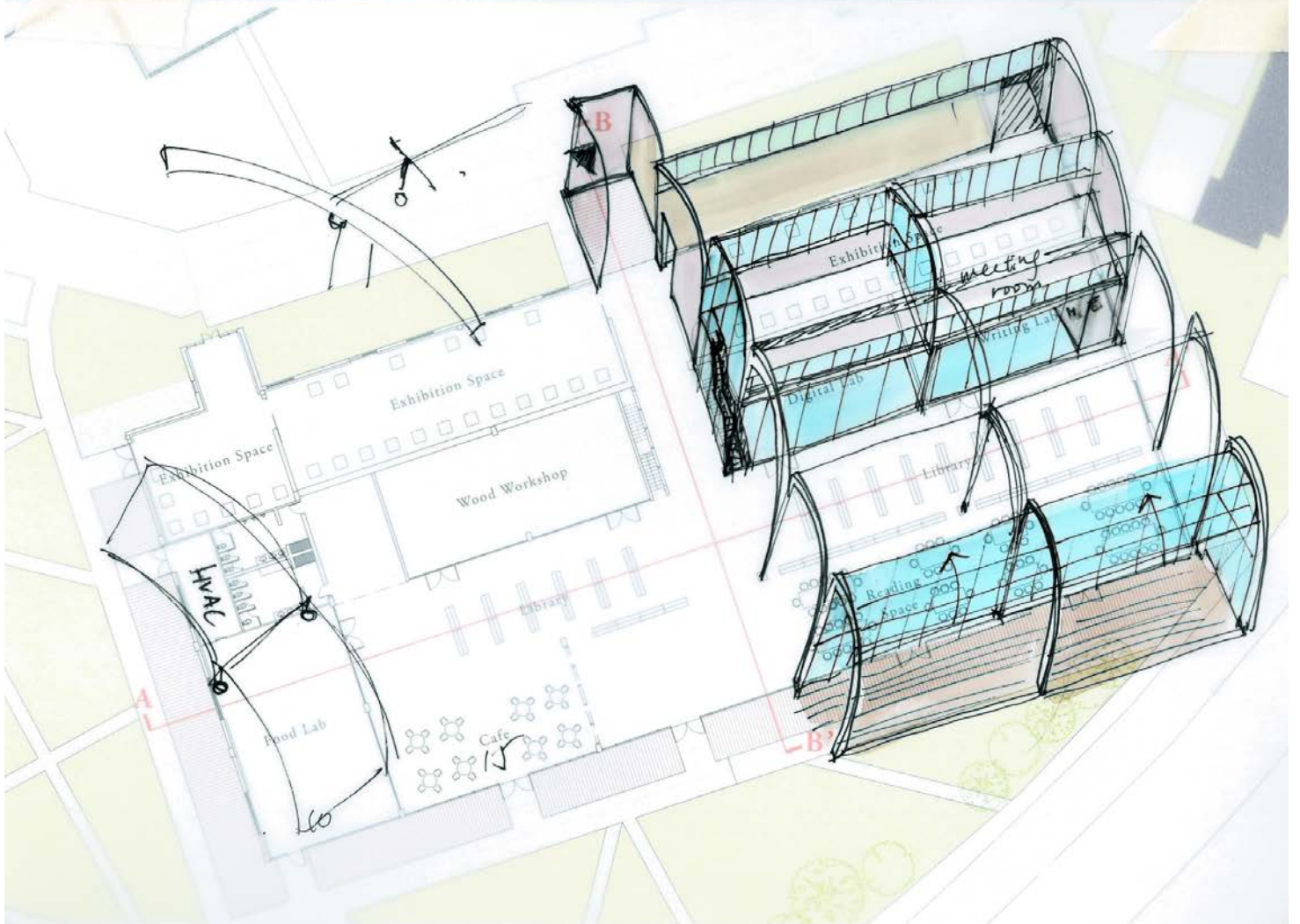
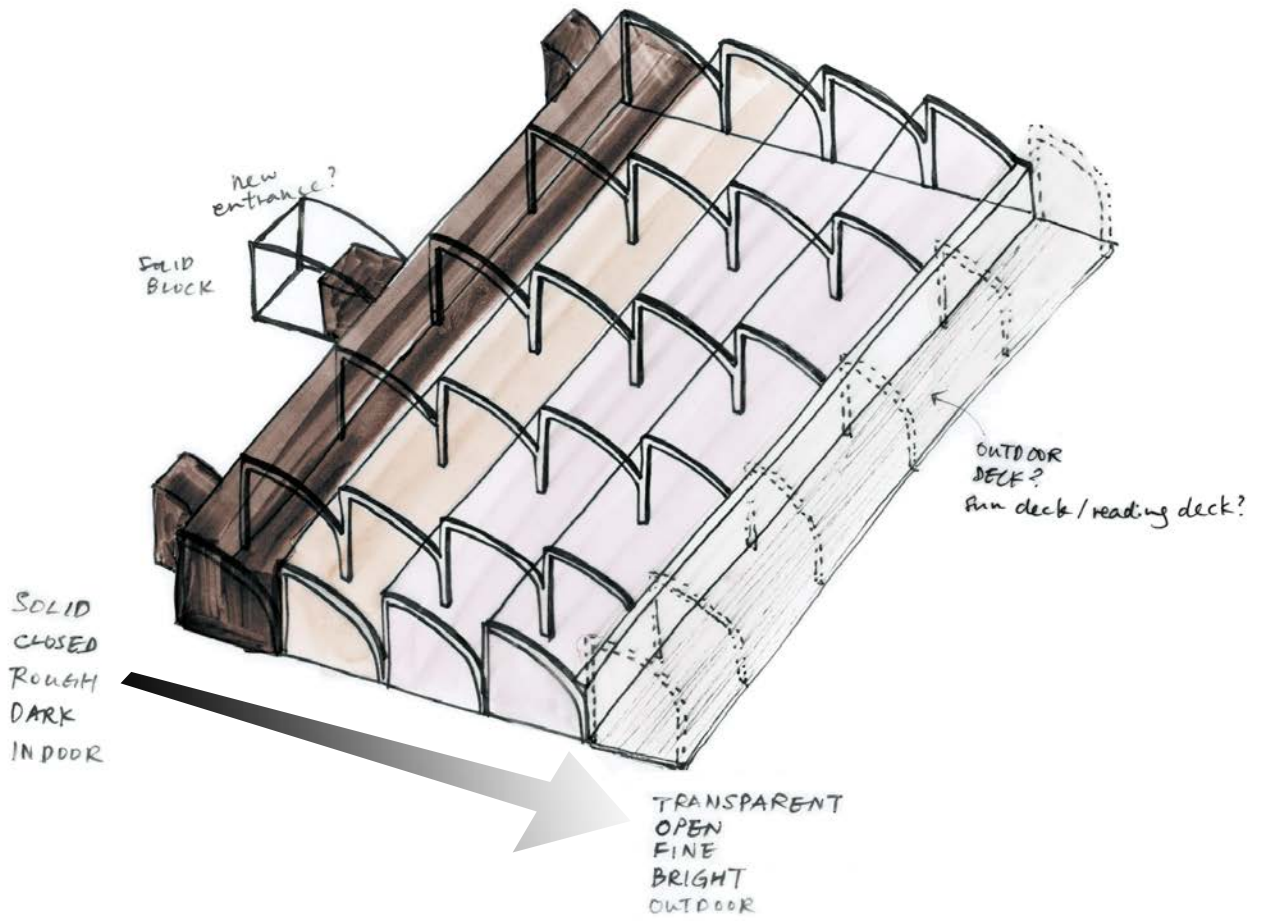

## SPATIAL CONCEPT

The ammunition factory is composed with four consecutive curved shell tubes. They create a rhythmical profile which is typical for the factories that were built in the 1950s. The spatial idea for the transformation is to create a gradual change throughout the four tubes, from solid to transparent, from closed to open, from dark to bright, from indoor to outdoor, from rough surfaces to fine finishes. In order to amplify the concept, a new transparent tube is added on the southern facade.

From the sketch below, the northern tube is the most solid tube which houses an exhibition space with original masonry wall partitions. The exhibition space can be separated into three individual exhibition rooms by closing the sliding doors. Moving towards the south, the second tube is semi-open. The glass partition walls reveal the activities inside different labs, for instance the digi-lab, the wood workshop and the writing lab. Additional floor area is added on top of the labs for quiet programs which require more privacy, for example, the meeting rooms and the study rooms. For the next two tubes, they are used together as a library and reading space. When one looks across the open expansive space, there is a food lab at the end of the hallway. The food lab can hold cookery courses and serve as a cafe to the library users. Lastly, the new tube on the southern facade is the most transparent volume.

*Top sketch:*

*The spatial concept of ammunition factory - from solid to transparent, from closed to open, from dark to bright, from indoor to outdoor.*

*Bottom sketch:*

*The programs inside the library are arranged according to the need of daylight.*

# PASSIVE DESIGN STRATEGY

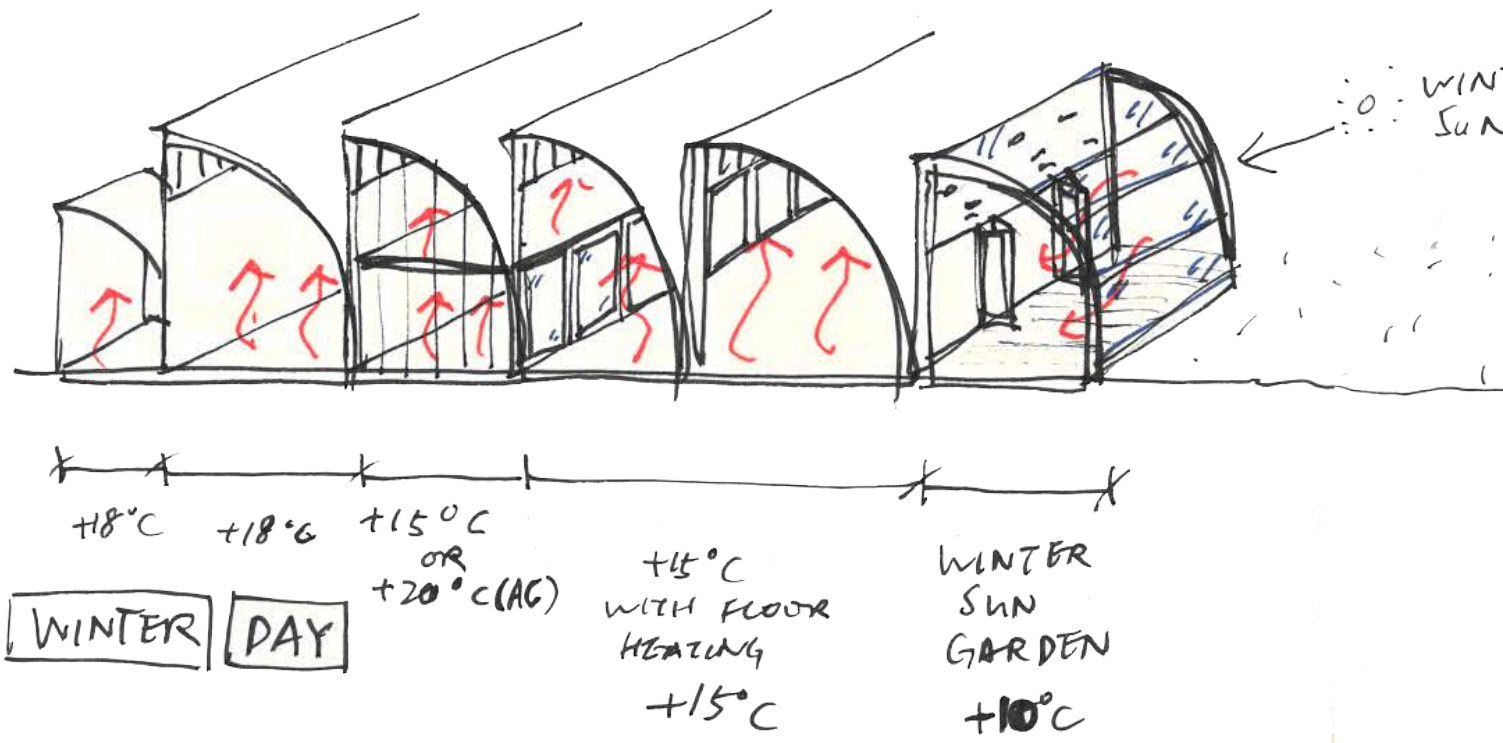
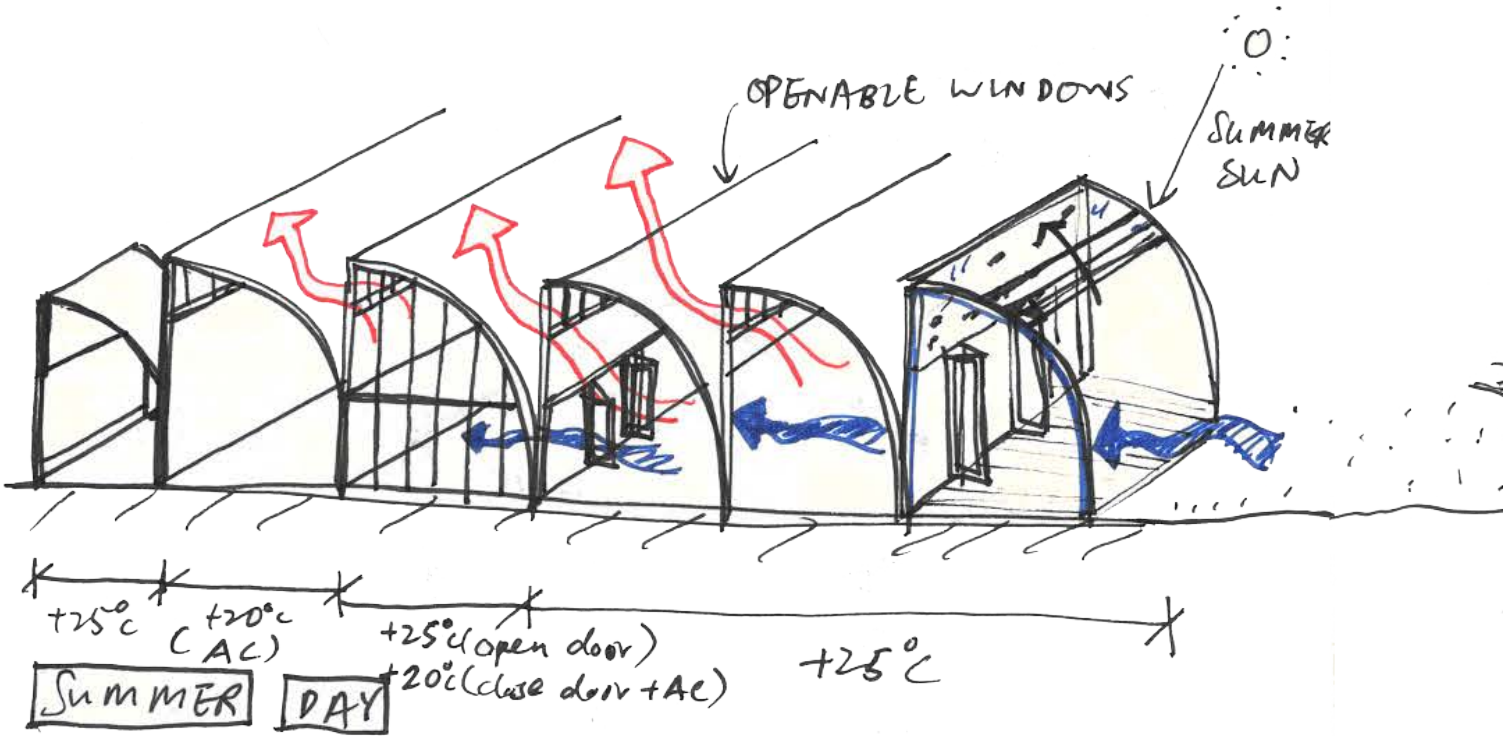



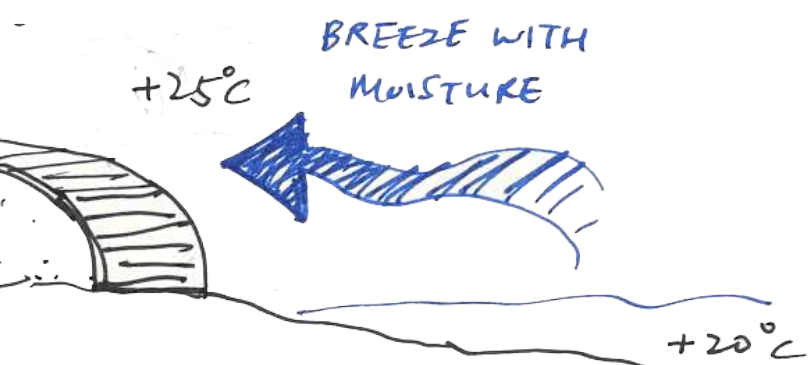

The new glass box can be open and closed to regulate temperature in different seasons. In summer time, the glass box is open to allow breeze into the building and thus enhance natural ventilation. In winter time, the glass tube will be closed completely and create a sun space to mitigate the cold climate.

# ACTIVE DESIGN STRATEGY

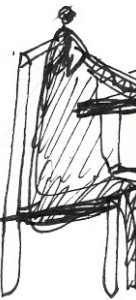
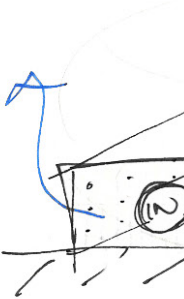
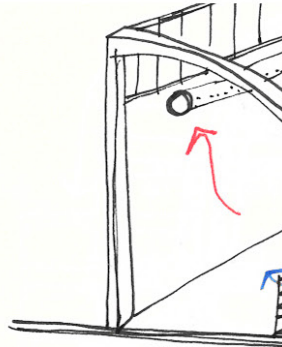
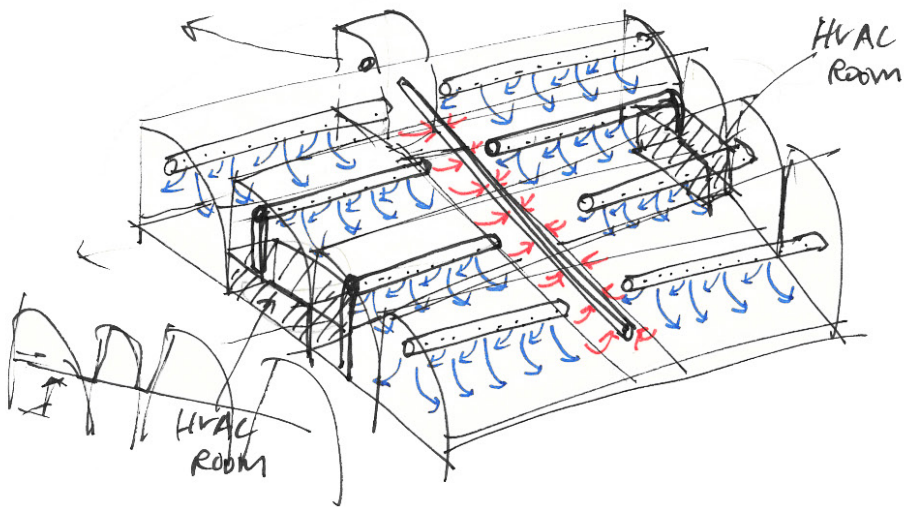
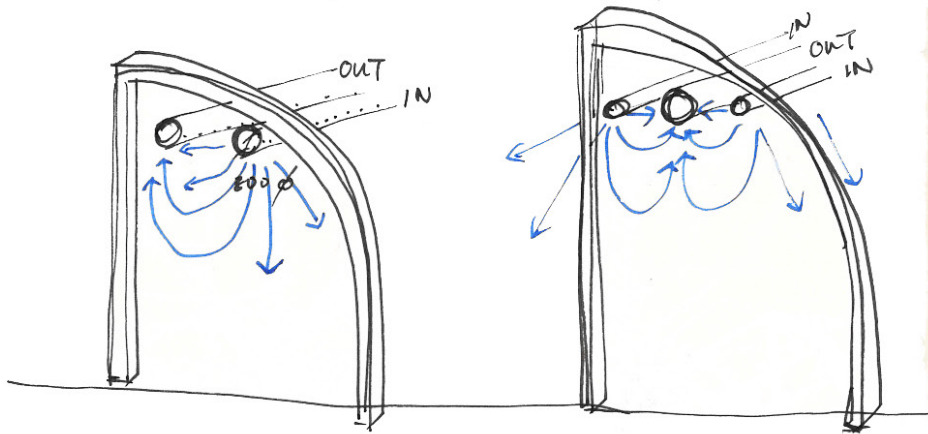
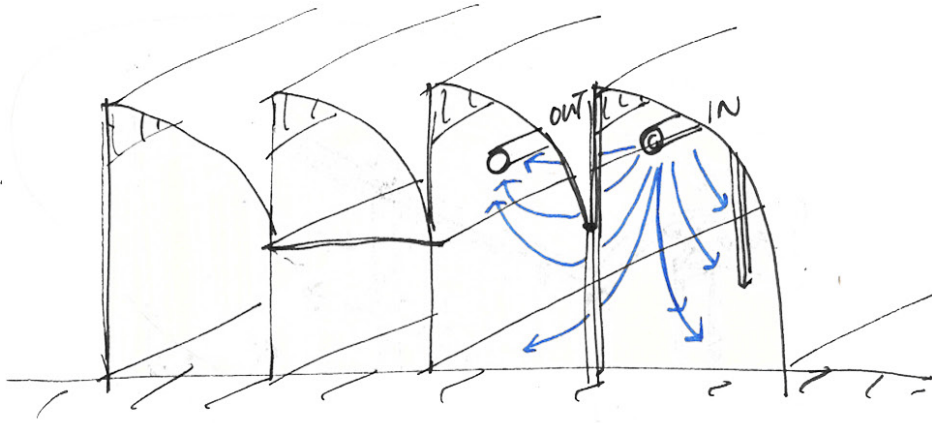

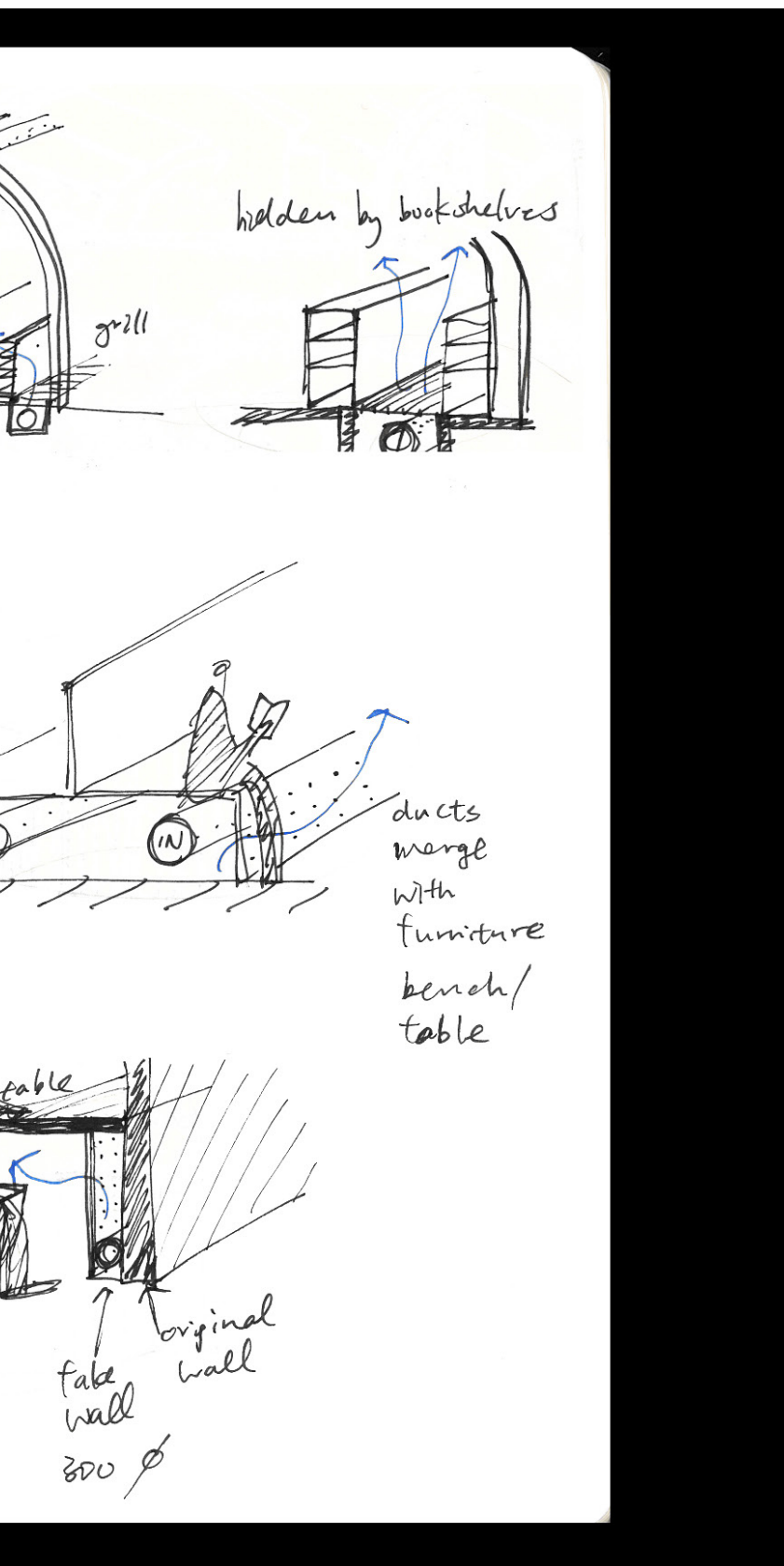

Besides the passive building design, the overall building comfort will also be achieved with the aid of active mechanical systems. The new design will integrate floor heating system into the new concrete floor which is poured on top of the existing concrete floor.

For ventilation system, a few options of positioning fresh air inlets and outlets have been tested as shown in the sketch. After evaluating the efficiency of each possible solution, the study shows that having air inlets near the ground level and outlets near the roof can attain higher energy efficiency and better result of human comfort. There are two HVAC rooms at the two ends of the building, each supports half of the hall. Air exhaust duct is located in the mid point of the building above the 'internal street'. The ducts and wiring are held within a space frame which also serves as an element to guide visitors through the building. There are also thoughts about integrating the ventilation ducts with furniture, for instance the benches and tables.



# RETRACTABLE TUBE IDEAS

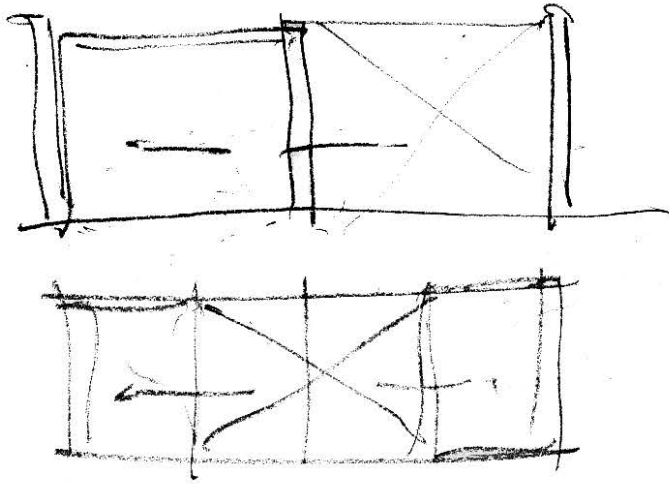

Sliding horizontally

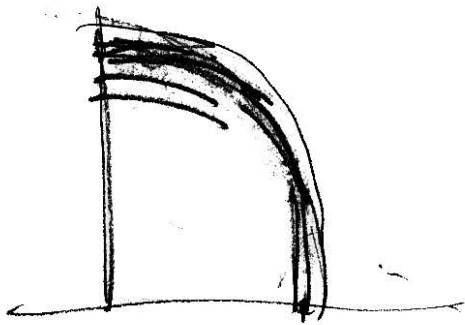
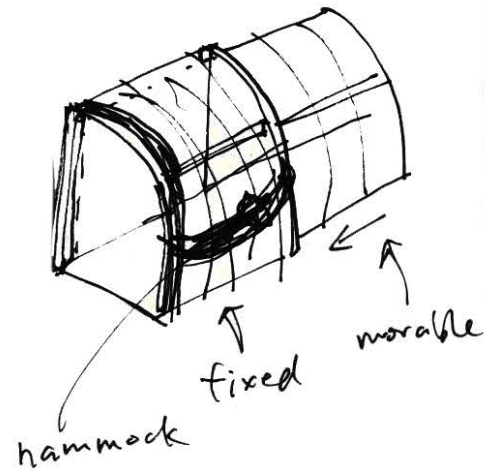

Sliding upwards

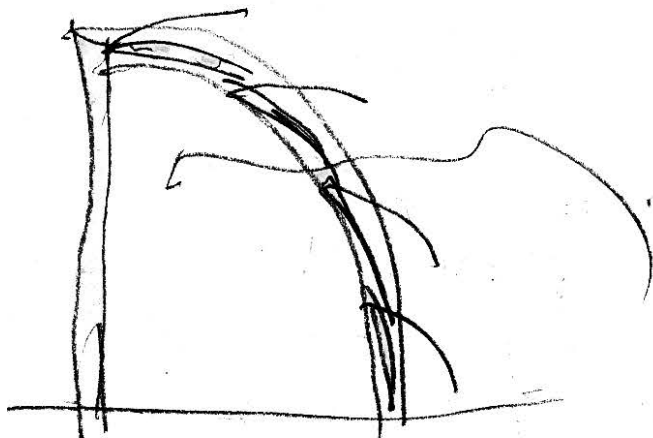
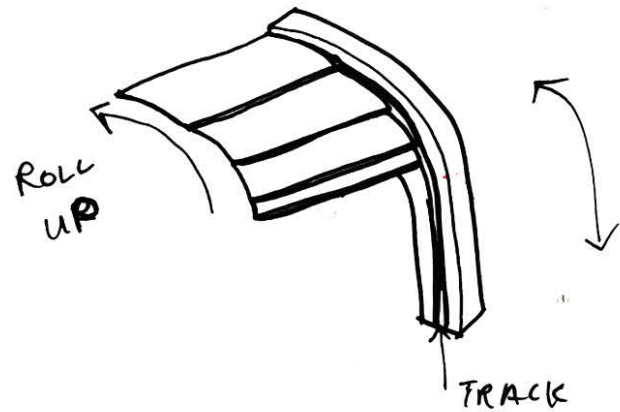

Rotate / Folding

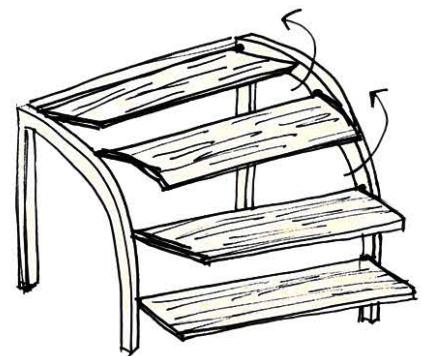

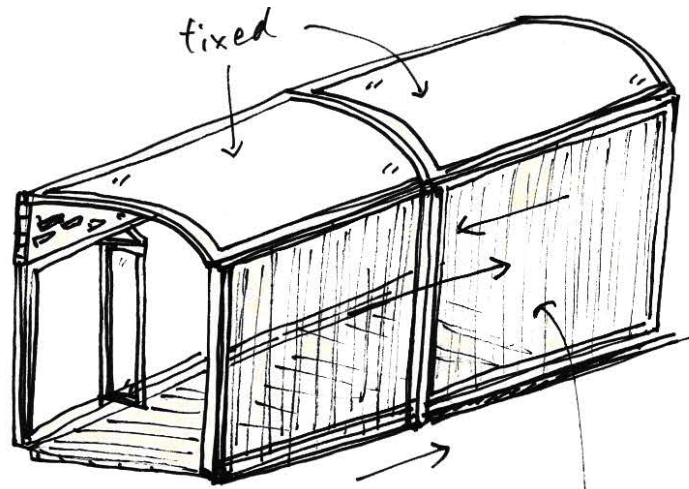
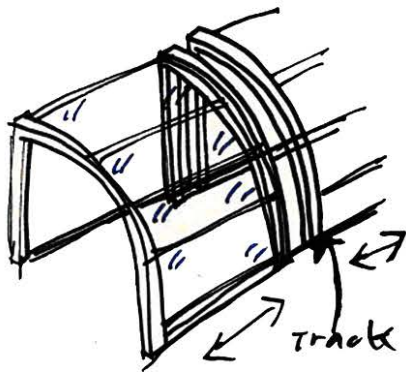

translucent  
glass / bamboo?

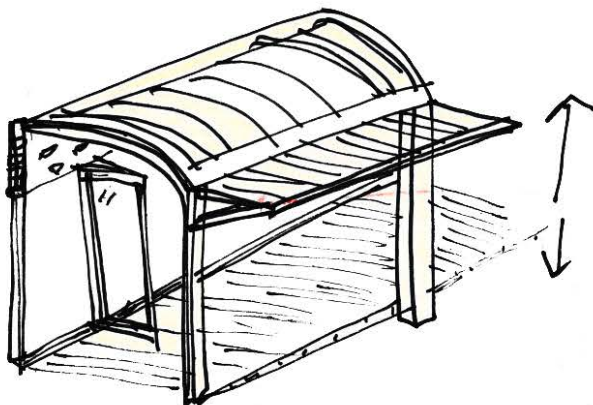

# STUDY MODELS

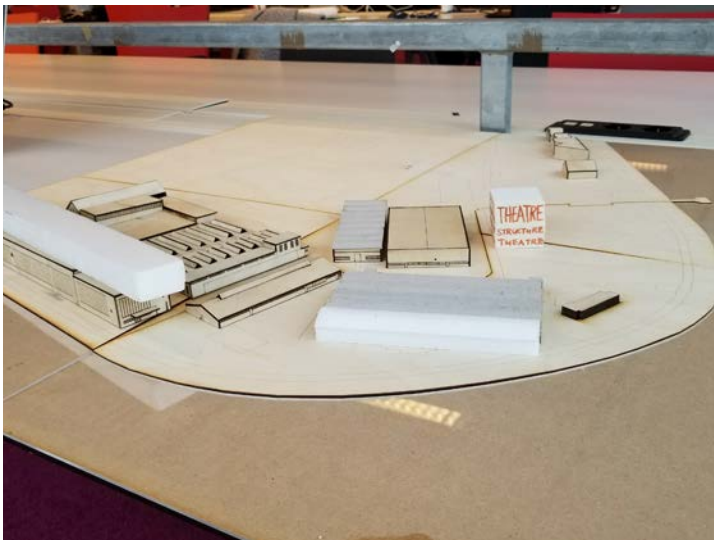









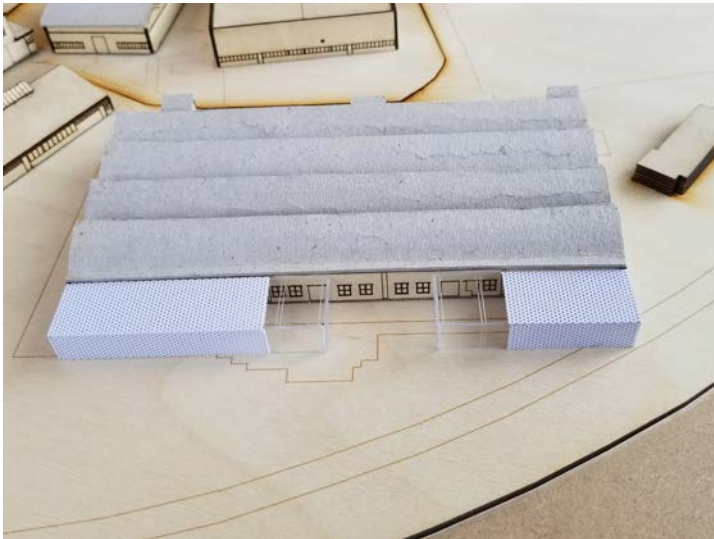
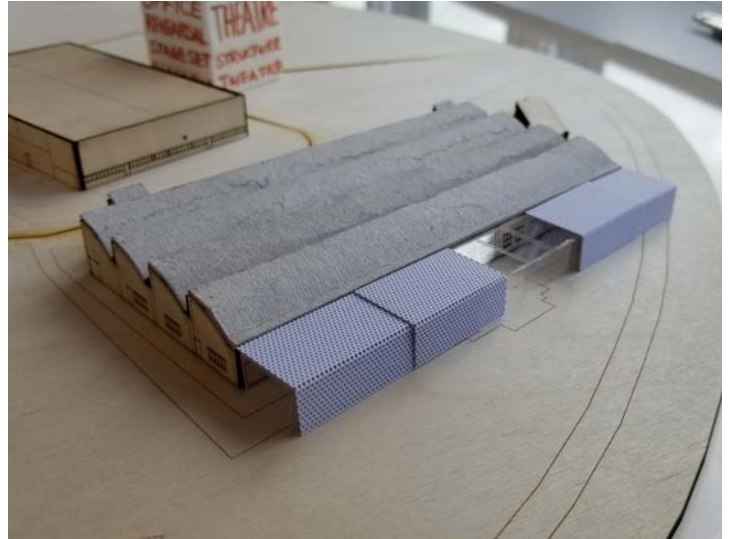



# CHANCES AND RISKS

## Chances

## Risks



- Reuse the building
- Add new volume
- Divide the space into smaller zones
- Enlarge south facade opening
- Make connection with outdoor space and canal
- New 'face' of Hembrug

- New volume may disturb the skyline
- New volume may diminish the architectural language - four curved roof tubes
- Partitions may disrupt open plan layout



- Reuse the building
- Tear down the partition wall to make a continuous space
- Make connection with outdoor space and canal

- Loss of original building material (e.g. Comb bricks)
- Loss of original building fixture (e.g. toilets, basins)



- Reuse the building
- Part of landscaping design
- As an object in public space
- Create a journey to discover the bunker

- Flooding problem
- Insufficient interior space

**Do**

**Don't**

**Remarks on Cultural Value**

- Keep industrial character
- Expose the structure and material
- Maintain the typology
- Keep the entrance as 'secret'
- Maintain the sight line to canal
- Allow flexibility by keeping the open plan layout

- Demolish the building
- Make a new height accent
- Destroy the spatial quality

- The appropriateness of the having an exhibition space within a solid closed tube
- Differentiation between the old and new volume
- 

- Keep industrial character
- Expose the structure and material
- Allow flexibility by keeping the open plan layout
- Create visual/physical connection to outdoor space and canal

- Demolish the building
- Renovate all of the facades

- Preserve the bunker
- Design for a public space
- Merge with landscape design
- Remove fence to increase accessibility

- Demolish the bunker



Producer



Consumer

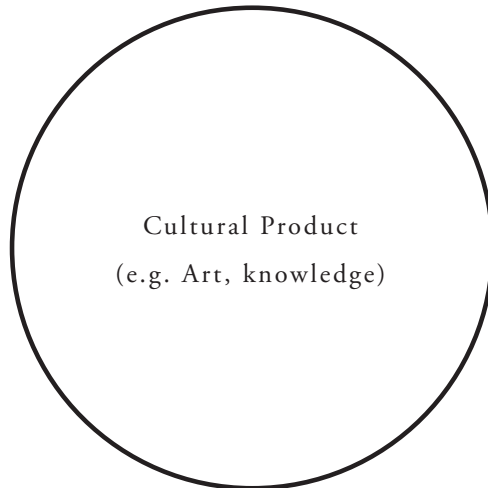

Cultural Product  
(e.g. Art, knowledge)

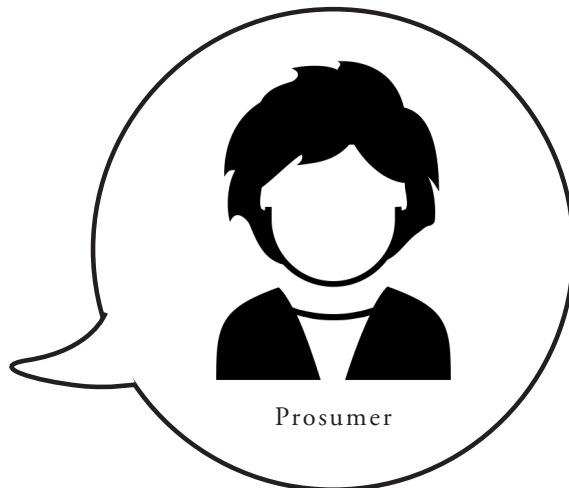

Prosumer





## PROSUMER CULTURE

The rapid development of ICT (Information and Communication Technology) encourages the general public to be a prosumer (a person who both produces and consumes a product) of cultural products, for instance we can watch and upload videos in YouTube. The idea of “prosumer” first appeared in Alvin Toffler’s book in 1980, *The Third Wave*, in which Toffler compares the agricultural society as the First Wave; the industrial Age as the Second Wave and the Information Age as the Third Wave. He predicts while in the Third Wave, the role of producers and consumers would be blurred and merged. The maker library provides the opportunity for people to be a prosumer of cultural products. People can learn how to create videos, audios, digital codes, artworks, models, to name but a few using the equipment given in the library. They are consuming the knowledge and creating cultural products which inspire the learning of the others at the same time. Through the simultaneous production and consumption of knowledge stimulates the growing innovative culture in the Netherlands. (Netherlands was ranked as the fourth country in the Global Innovation Index in 2015 and promoted to the second place in 2018. )

*Source:*

*Toffler, Alvin. The Third Wave. New York: Bantam Books, 1981.*

*GLOBAL INNOVATION INDEX 2018: Energizing the World with Innovation. Place of Publication Not Identified: WORLD INTELLECTUAL PROPERTY, 2018.*

P3 PRESENTATION



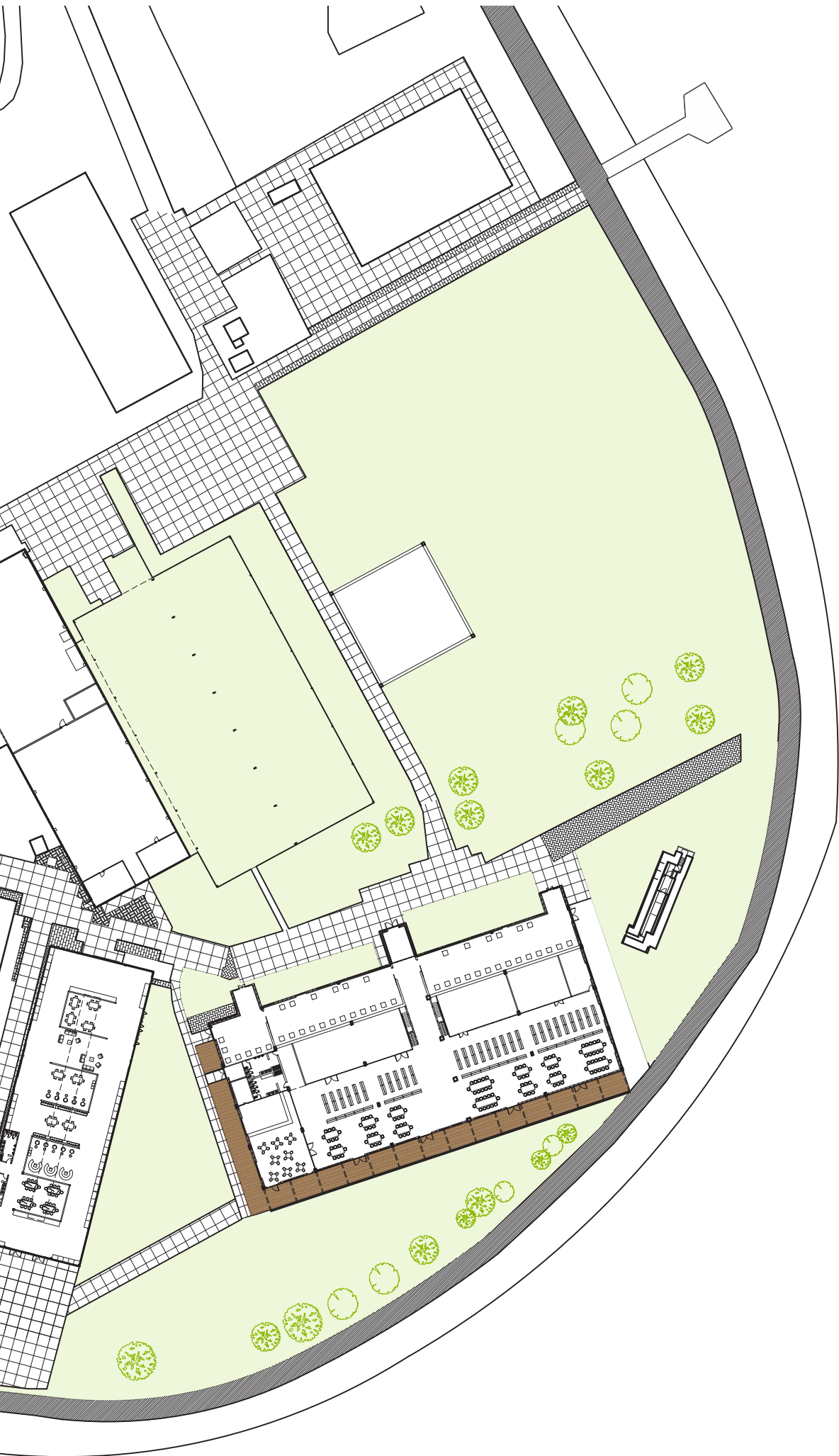





Exhibition Space

Fabrication Lab  
(3D Printing, Laser cut, Textile)

HVAC

Storage

Food Lab  
(Cafe)

Library

Sun Space in V

A

B



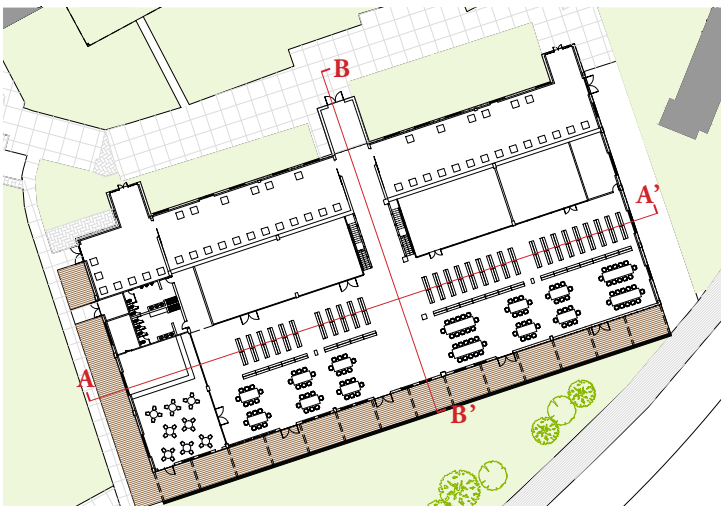
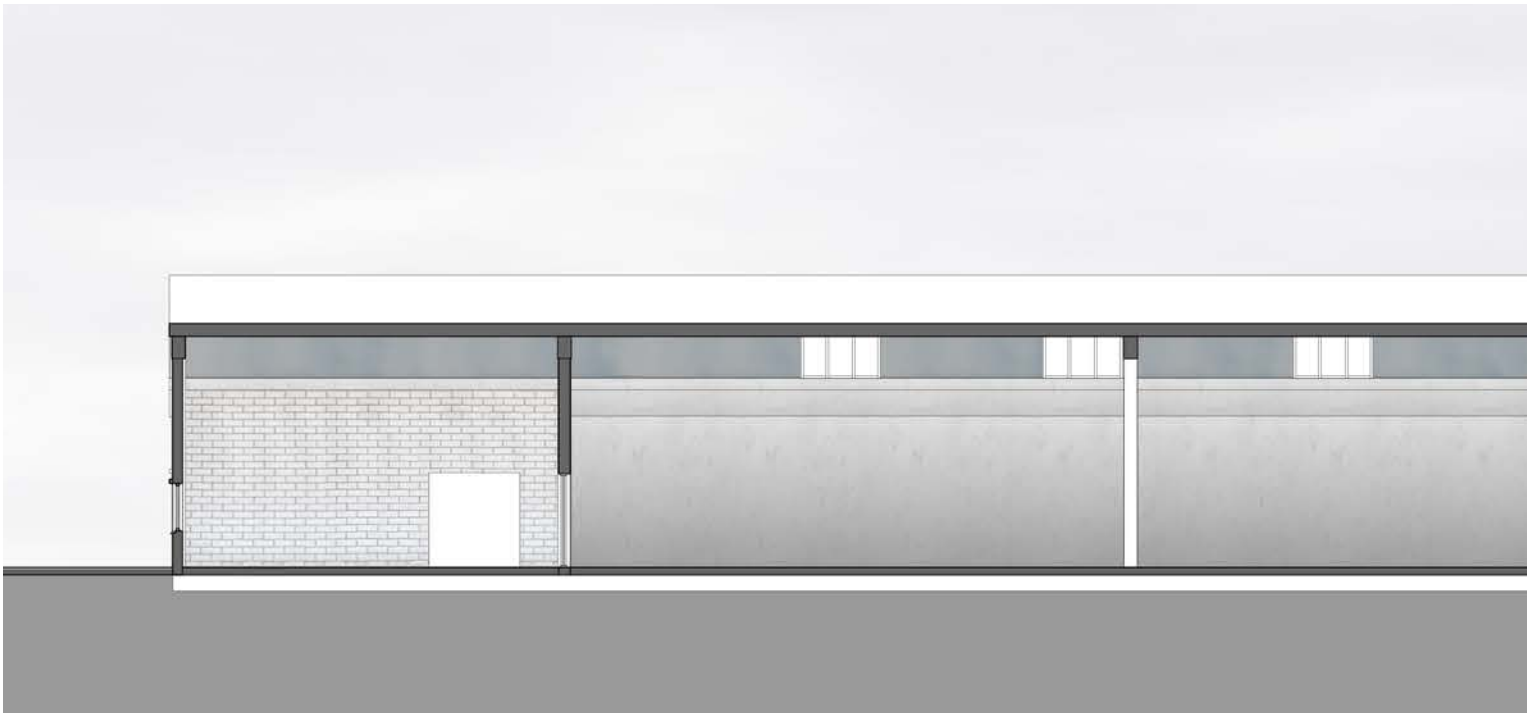



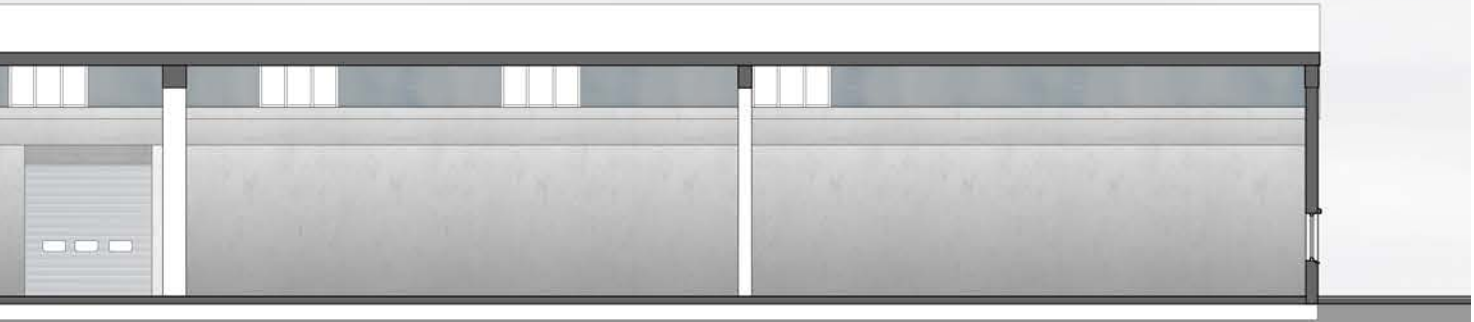

*Current Section A-A'*

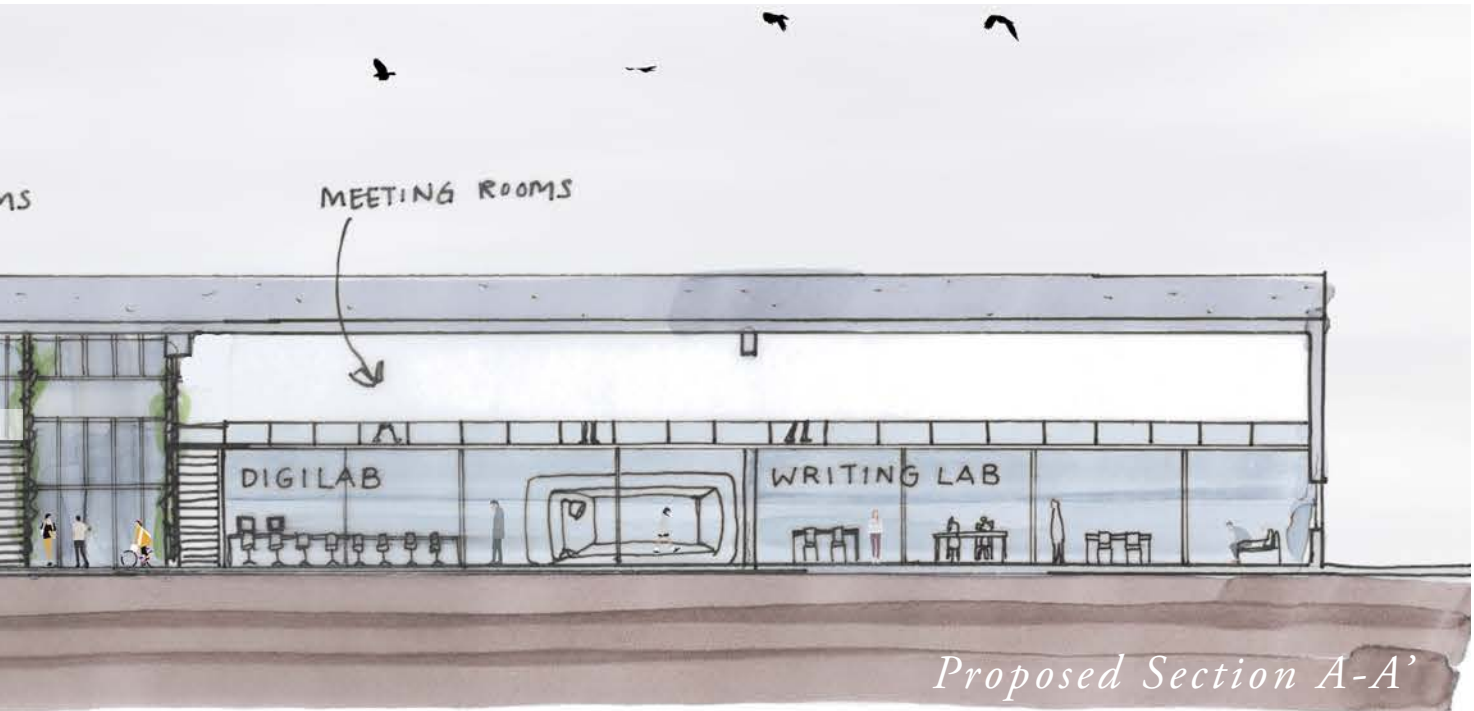

*Proposed Section A-A'*



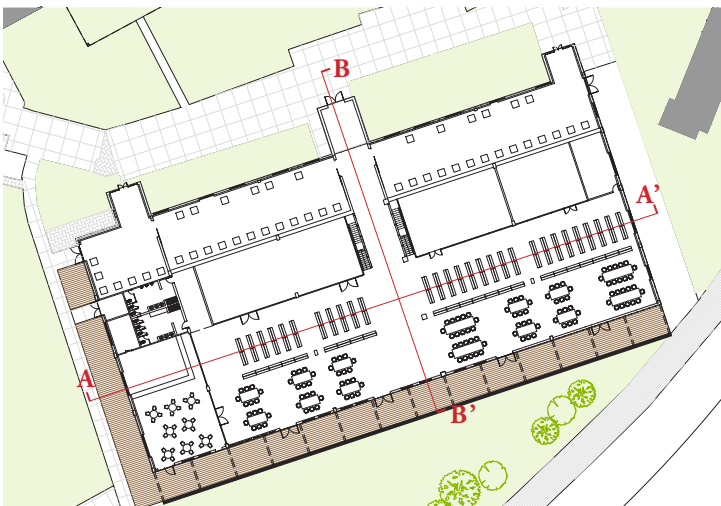
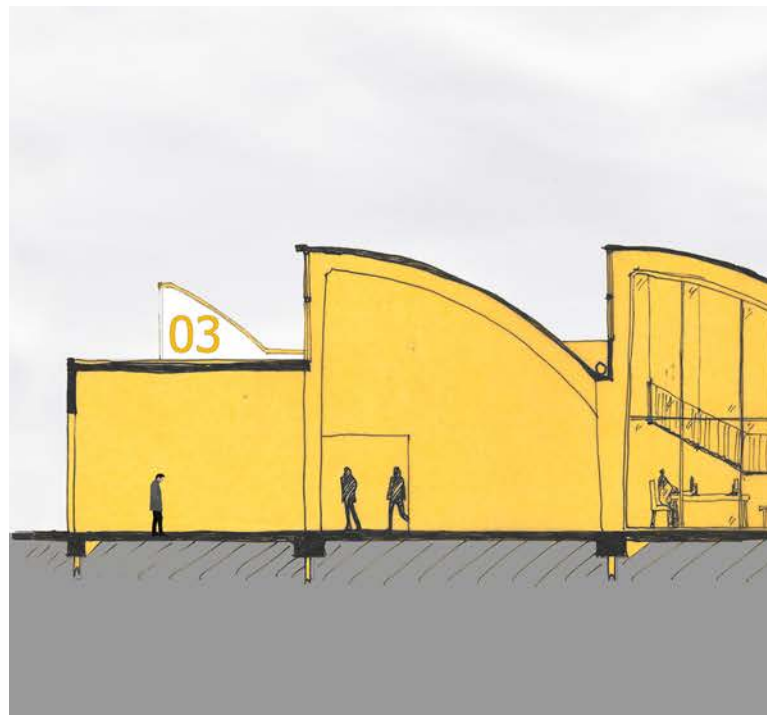
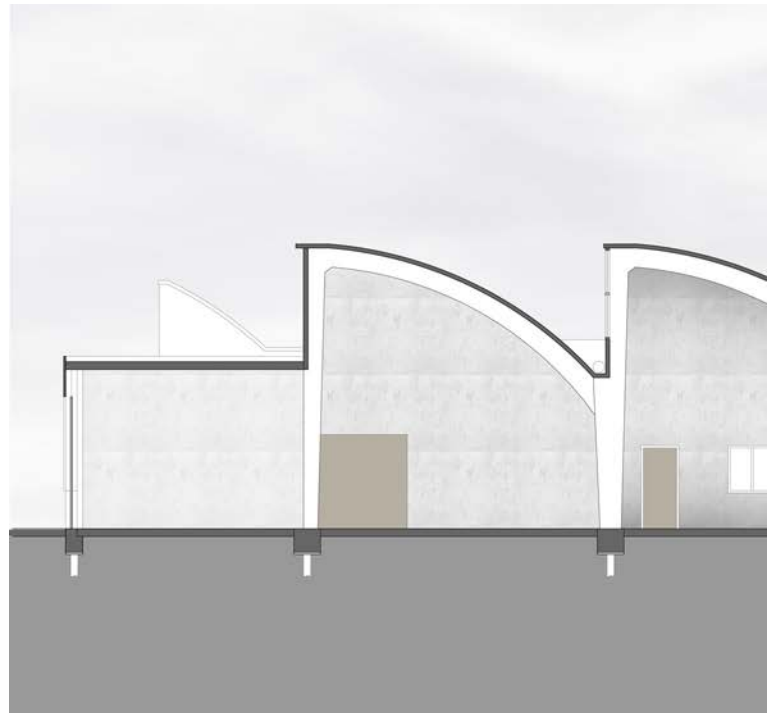

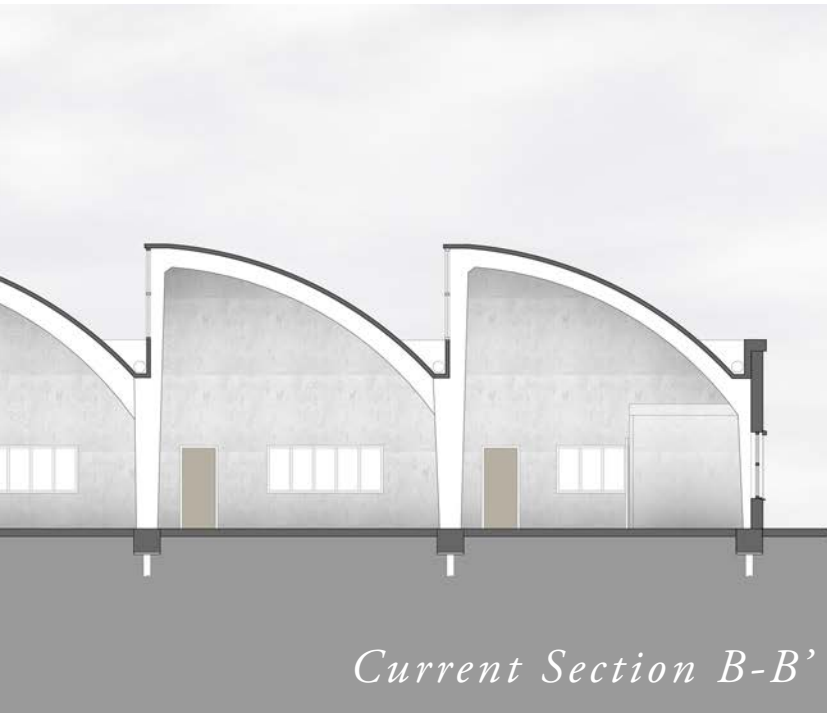



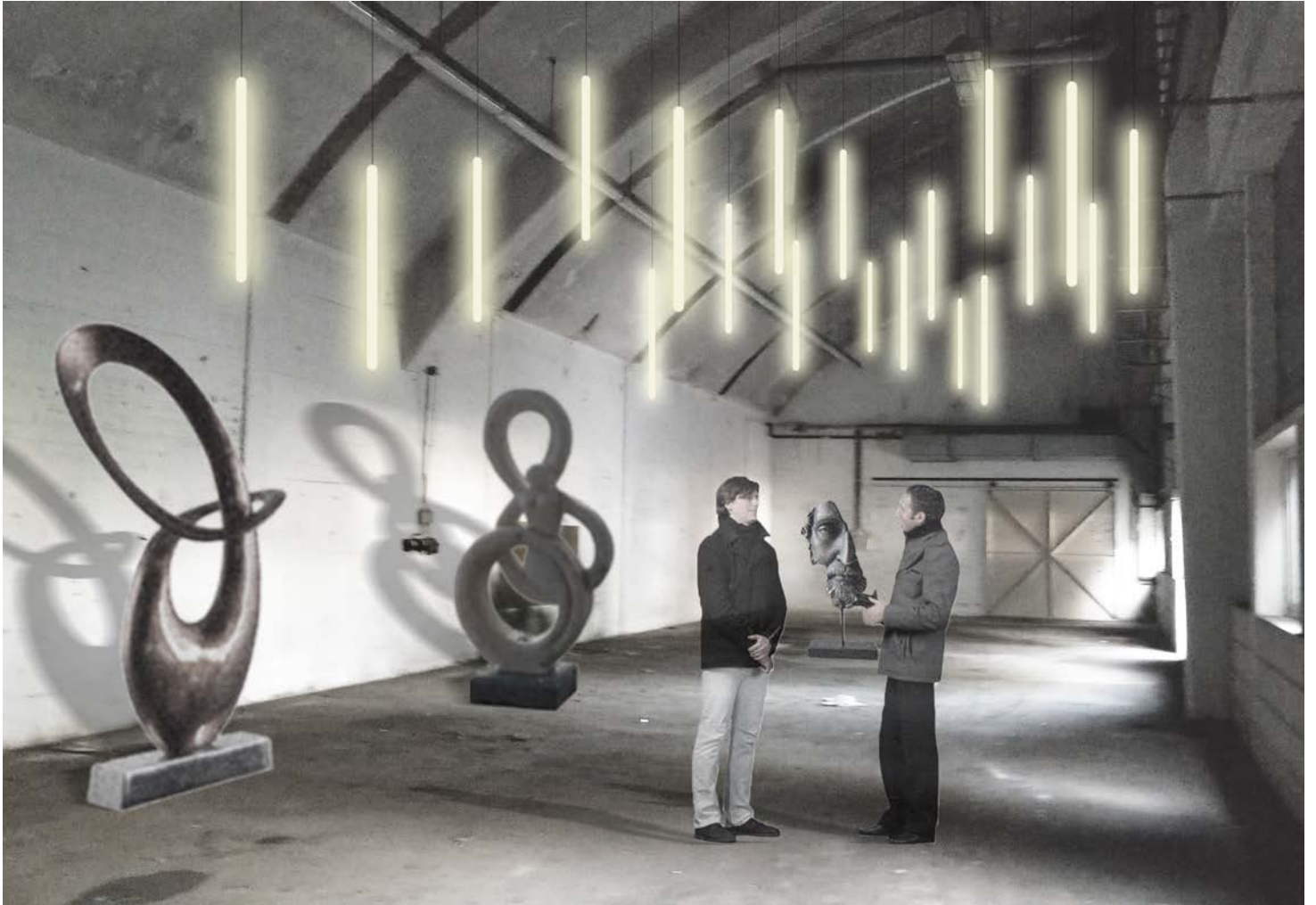

The northern tube will be transformed into exhibition space. The space can be divided into three smaller rooms when needed by sliding the original metal doors. Cultural products produced in the vicinity, for example, the woodwork assembled in the wood workshop nearby, the pottery made in the art studio, the artwork produced by library users in the labs, or even the VR product experimenting area.



New floor will be added in the second northern tube. The mezzanine houses programs which require privacy or silence, for instance the meeting rooms and study rooms. People working there can have a visual connection to the main space through the long strip windows. Under the mezzanine, there are three labs on the ground level, including the fabrication lab, media lab and digital lab.



The new tube is composed by two layers, the inner structural glass layer and the outer sun shading layer. The two layers can slide on the tracks to create various combinations according to different climate conditions. The tube will serve as an outdoor sun deck in Summer with both of the layers slid to the two ends. In case of noon or thunderstorm, both of the layers can be closed to provide sun shading or rain and wind proofing.





In winter time, the sun shading layer is pushed aside, exposing the inner glass tube to the sun. The tube will be heated up to mitigate the climate inside the building. The glass layer can also stop the strong wind from outside. The tube allows library users to enjoy the canal view in a controlled comfortable environment.

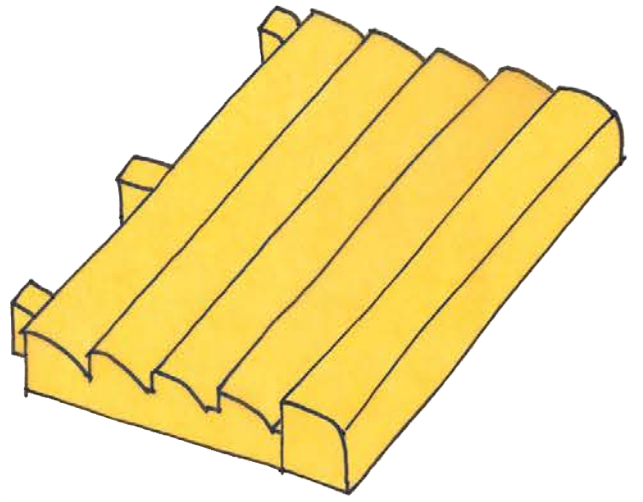
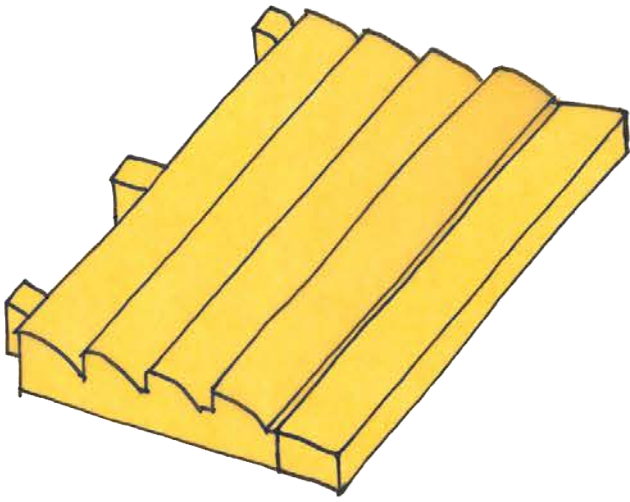

# REFLECTION ON CULTURAL VALUE

## **Form of new mass**

There are some struggles during the design process regarding the new mass, whether the new volume should follow the existing typology. The rectangular option is more feasible and practical, however it may shatter the strong character of the existing building - the repeated tubes. On the other hand, the curved tube option may incur in high construction cost and difficulties in maintenance.

After evaluation, I decided to go for the curved tube design since it can magnify the character of the building. I also would love to take the opportunity to challenge myself.



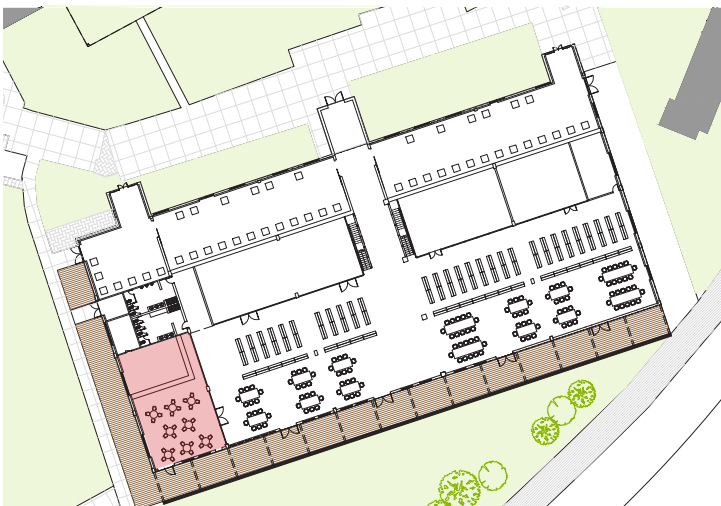

**Program and former function**

When I was organizing the programs, I tried to reference to the former function within the building. By doing so, there may be opportunities to relate the new program to the former one. The new design can remind the users of historical events or even the daily life of a factory worker in the 1950s.

Knowing that one part of the ammunition factory was used to be a washing area where some chimneys can still be found, it inspired me to change the function of this area into a food laboratory.

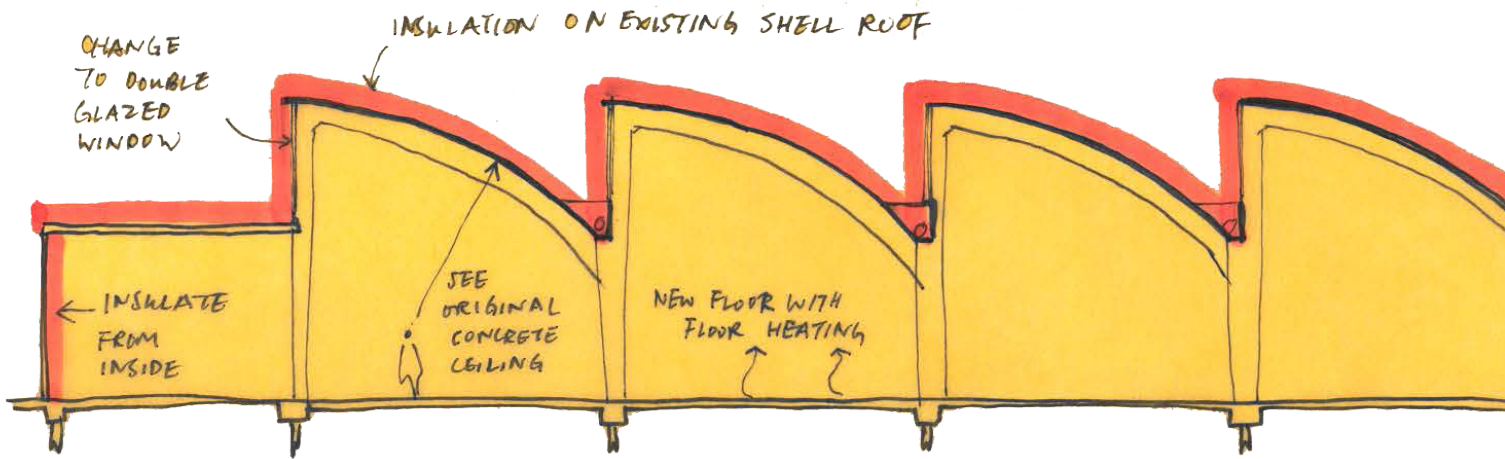



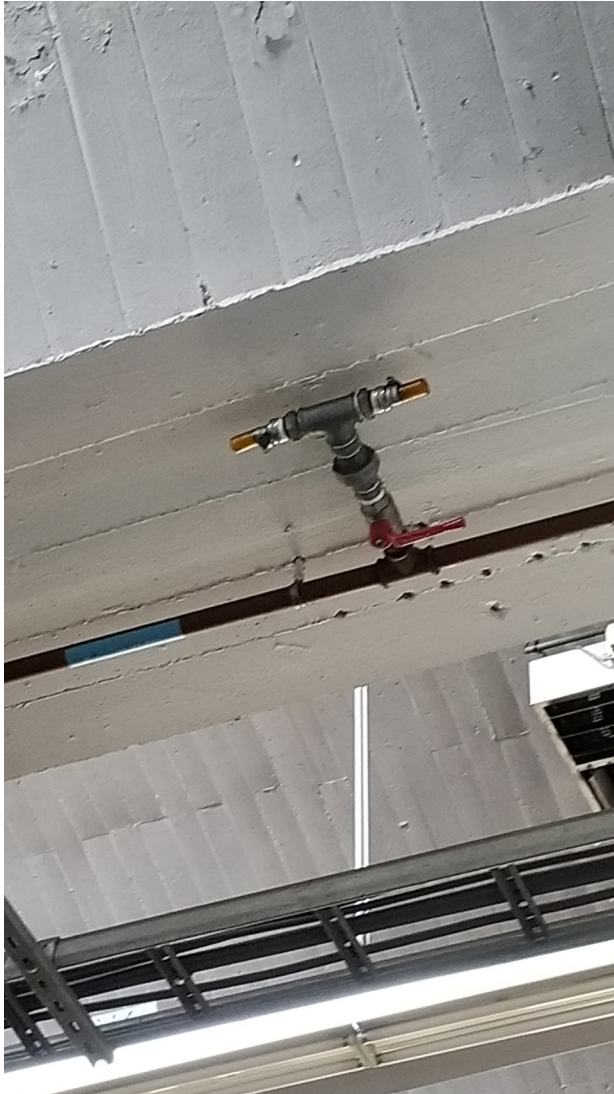

**Expression of original structure and material**

The cultural value of the building is kept by preserving the original materials, the concrete shell roof for instance. I deliberately put insulation on top of the roof so that visitors can still observe the original state of the material.



- WINTER
- INSULATED (WINDOW & ROOF)
  - SUPPORT WITH FLOOR HEATING WHEN NECESSARY









### Contrast between old and new

The new mass established a very interesting relationship with the existing south facade. When the new tube is opened and turned into an outdoor wooden deck, the original facade becomes an exterior wall. When the tube is closed and transformed into a sun space, the south facade will become an interior wall. The new addition blurs the identity of the masonry wall.

Besides, the new tube is literally a new time layer, which can be slid aside and reveal the mask of Hembrug's military history.



# BUILDING PHYSICS

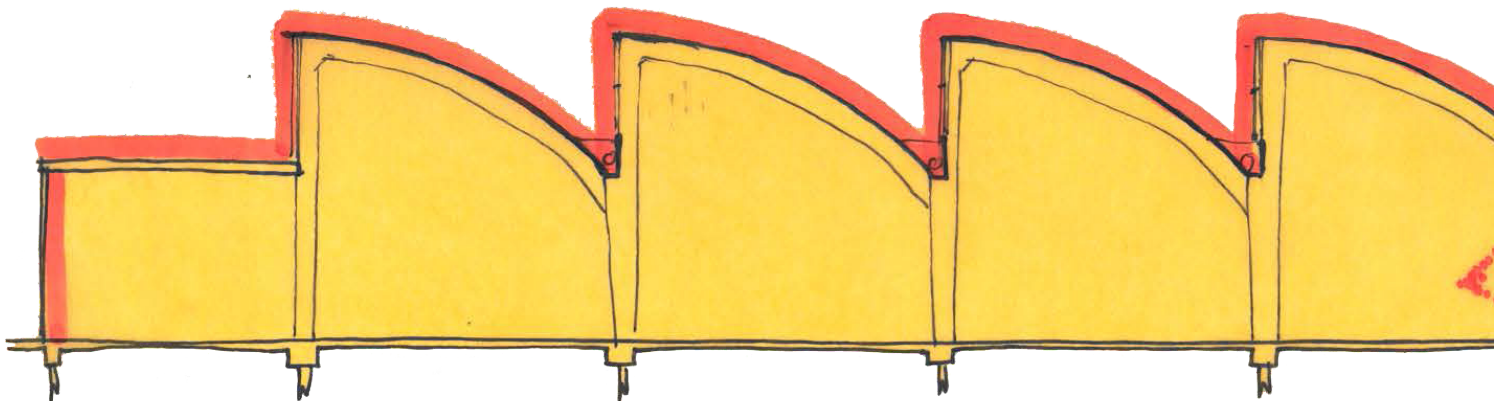
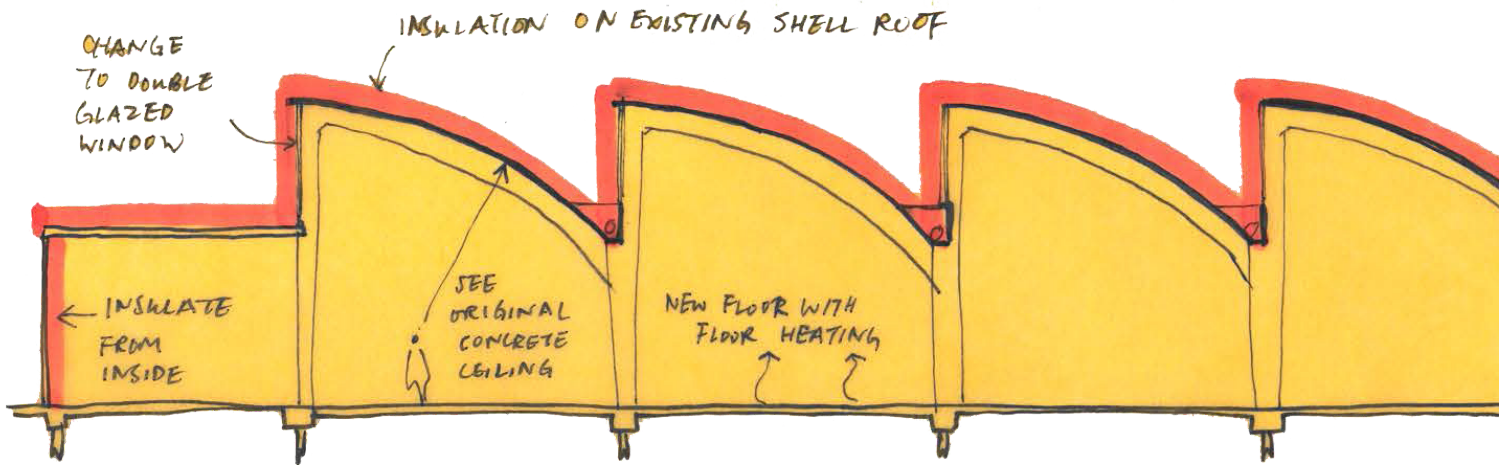
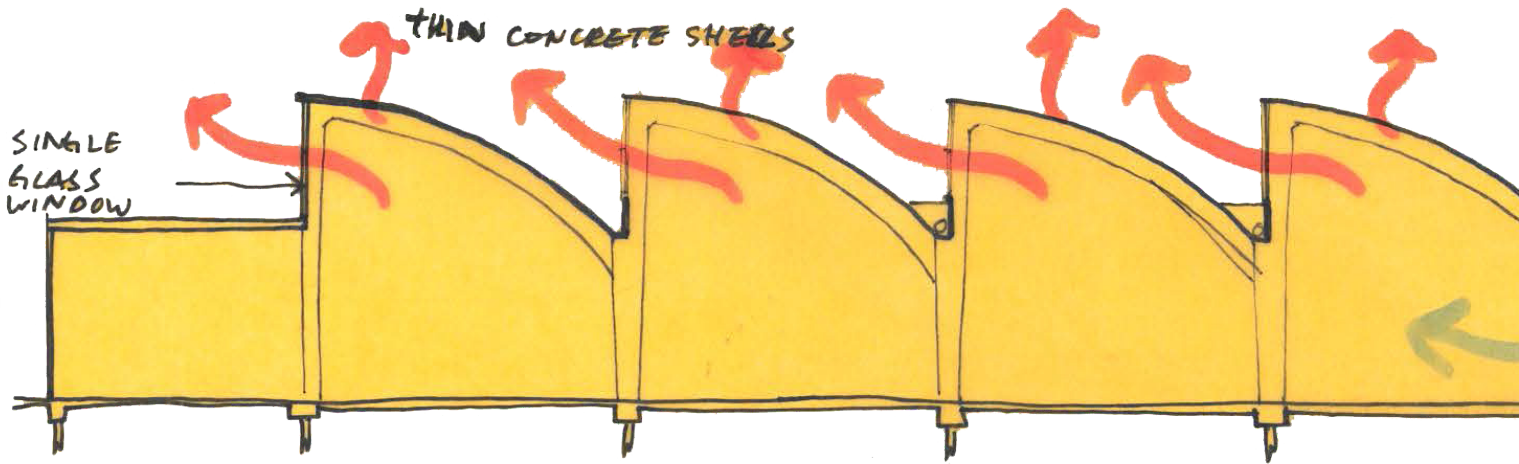



WINTER

- POOR INSULATION
- CAN'T RETAIN HEAT



WINTER

- INSULATED (WINDOW & ROOF)
- SUPPORT WITH FLOOR HEATING WHEN NECESSARY

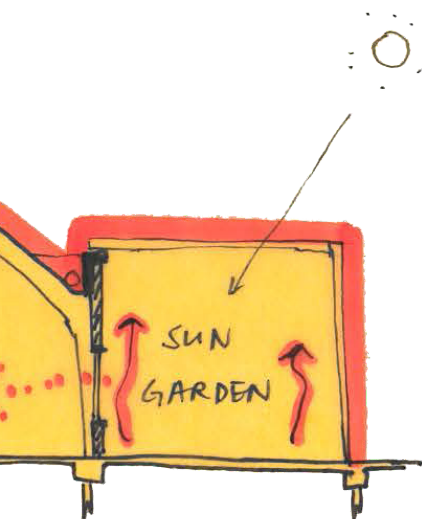

WINTER

- RETAIN HEAT
- MEDIATE CLIMATE

Current building physics:

- Poorly insulated due to the single glazed windows and concrete shell roof
- Failed to retain or produce heat in winter

Proposed intervention:

- Insulate the walls from inside
- Insulate the roof from outside in order to keep the authentic roof visible
- Change all the windows into double glazed
- Install floor heating

Additional mass:

- Help to retain heat in Winter
- Mitigate climate in different seasons

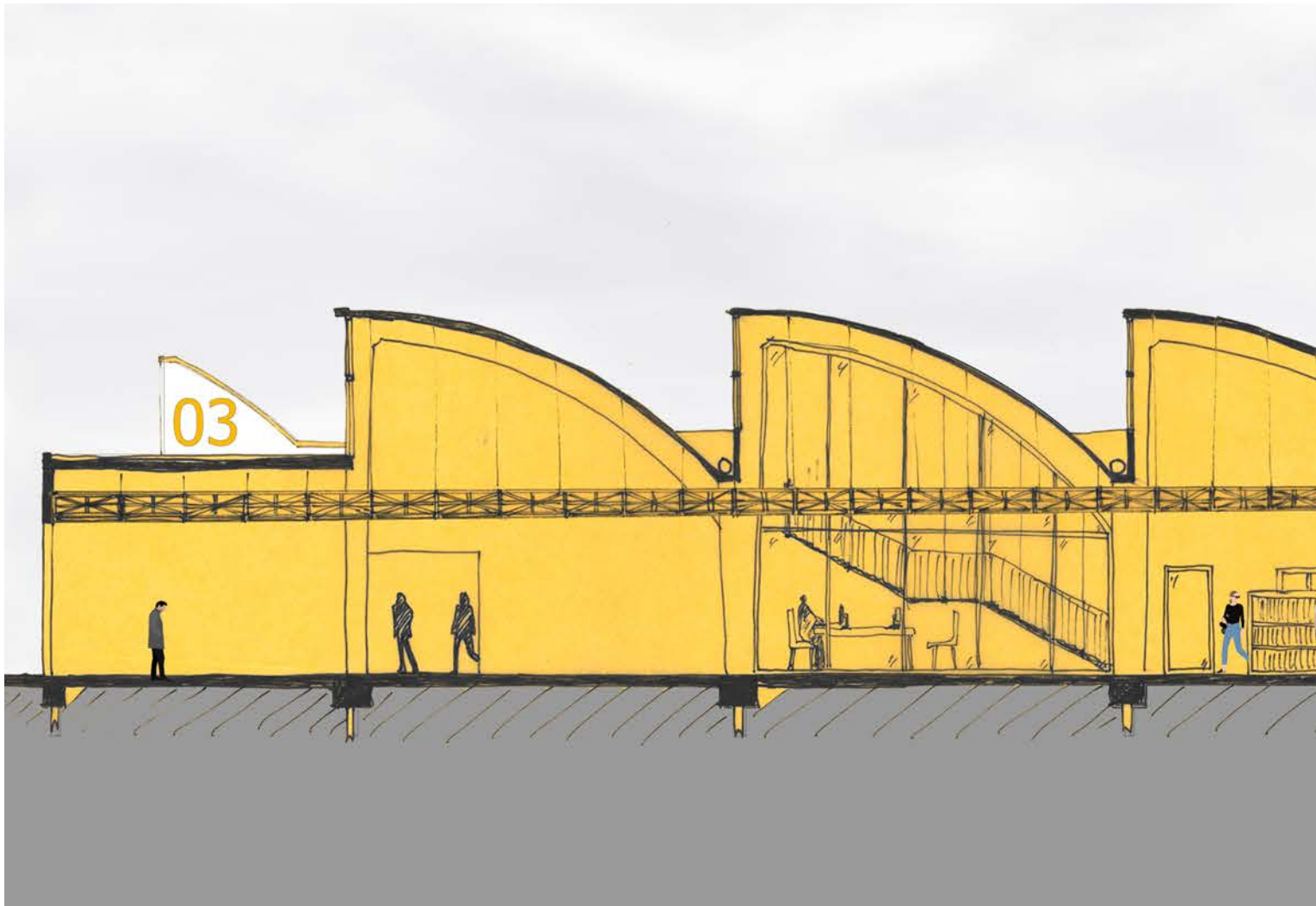
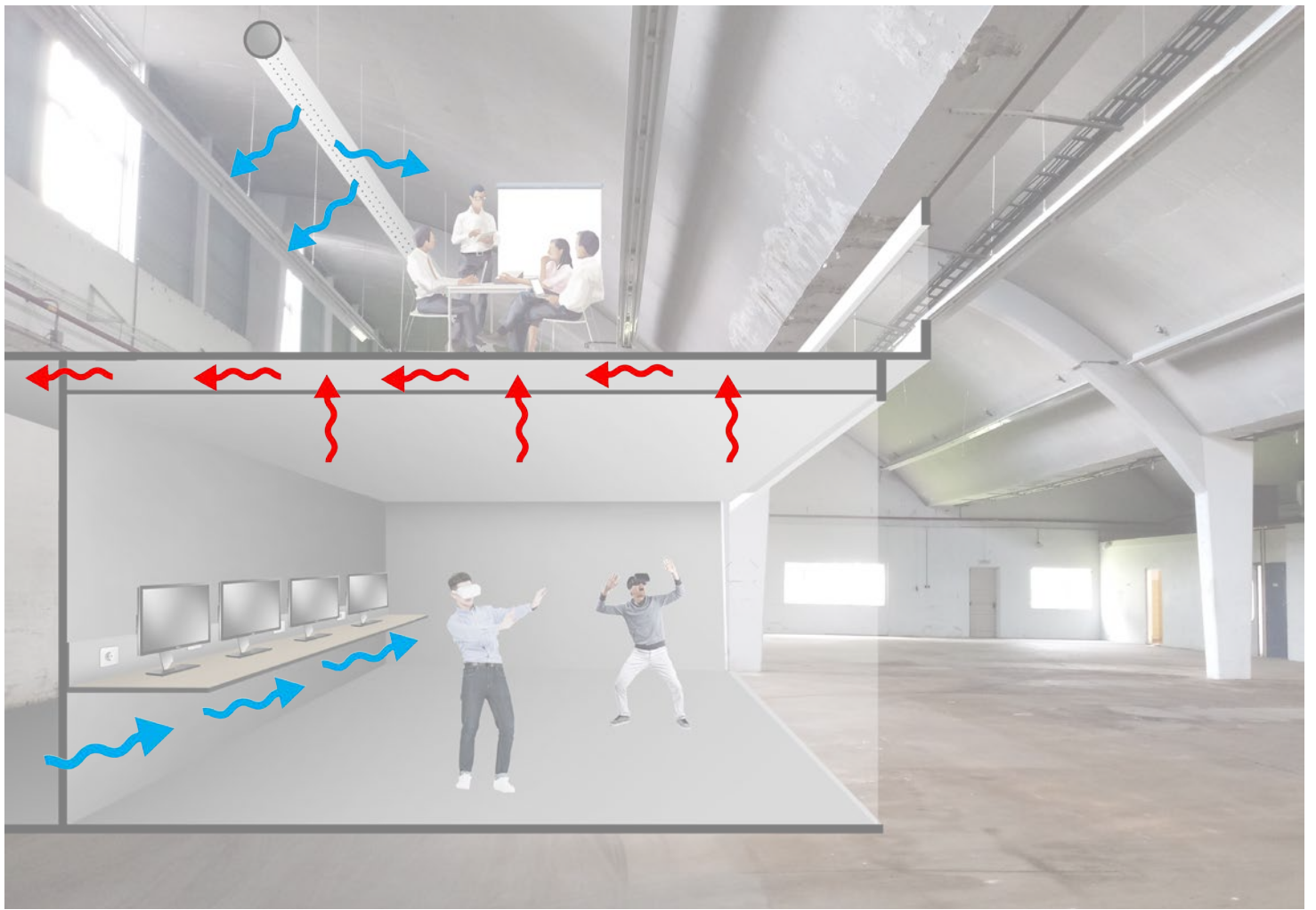



## HVAC System

There are thoughts about the mechanical system of the building. Although the new mass can help adjusting the indoor climate, individual mechanical controlled environment should be provided to cater the specific functions in the laboratories. Therefore, a shear wall is erected to support the mezzanine floor and simultaneously separates a mechanical corridor where all the pipings are placed.

The laboratories will have fresh air supply near the floor. Air is exhausted through the pipes hidden above the false ceiling and returned back to the mechanical room for heat exchange purpose.

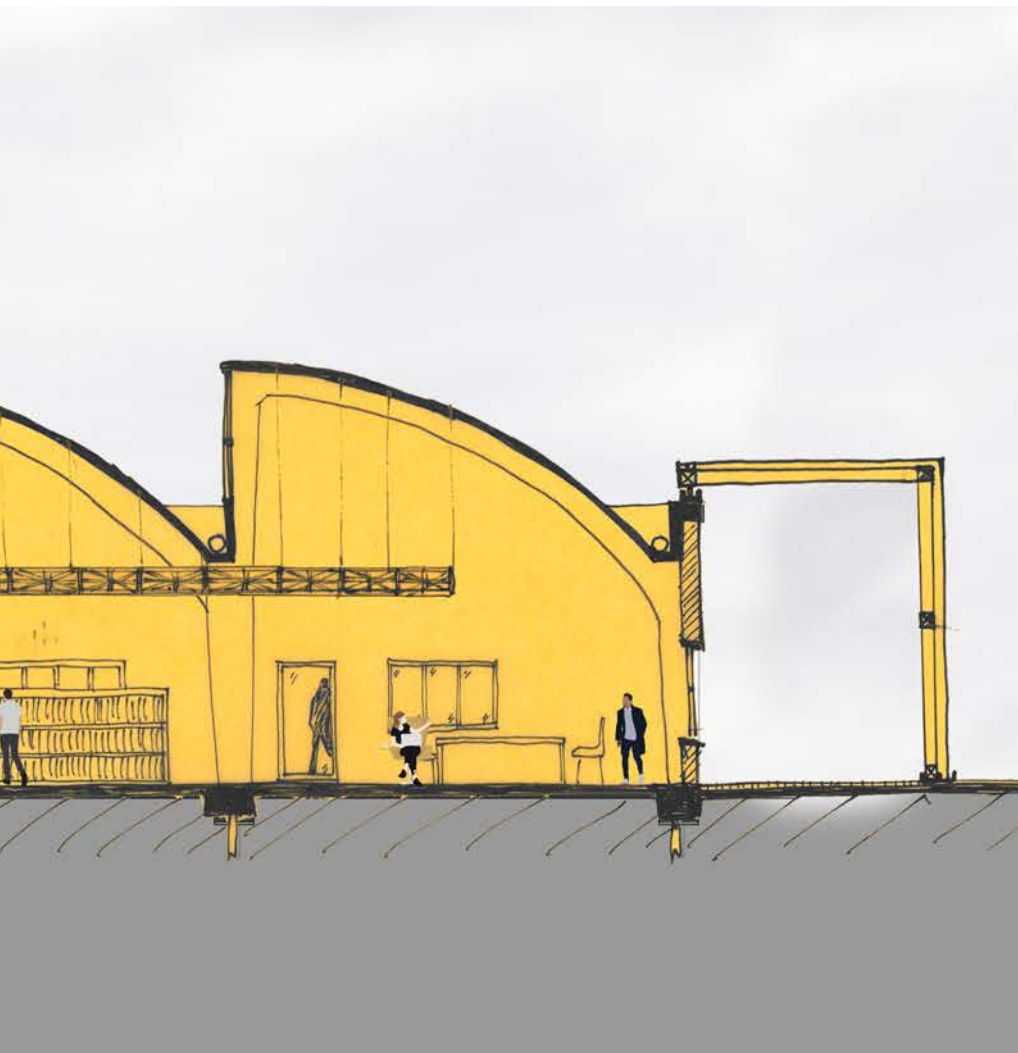

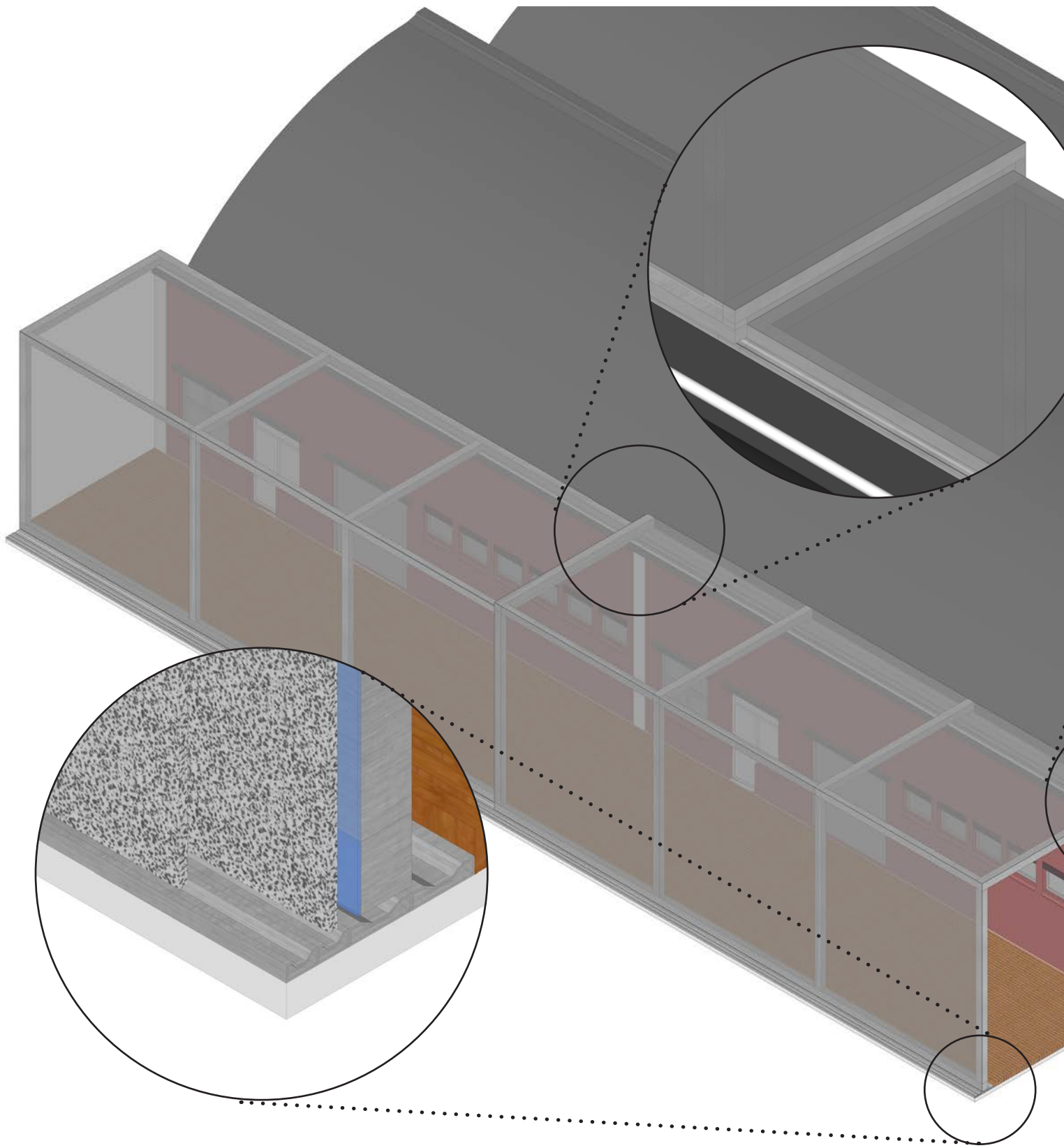

### Connection Details

When I tried to figure out the connection details of the sliding panels, I realized it is better to design the new volume as a self standing structure so that it is independent from the existing masonry wall. This testing out trial has set the structural principle of the new addition.

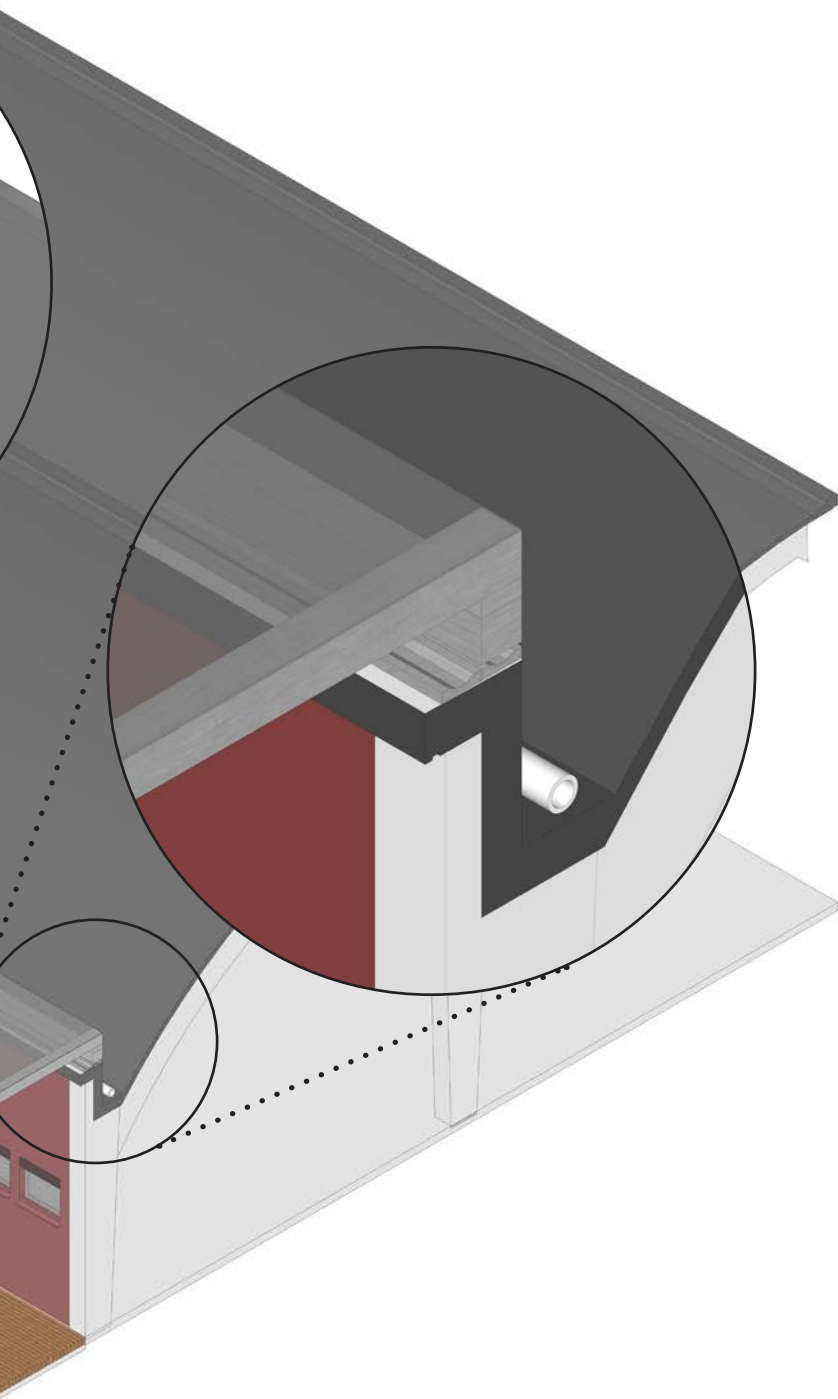







P4

*Production*

SITE MAP







TARGET GROUPS



Museum visitors  
5000/day



Local artists  
50

MUSEUM

PARKING

ATELIER

WORK



Haven-Stad  
150,000



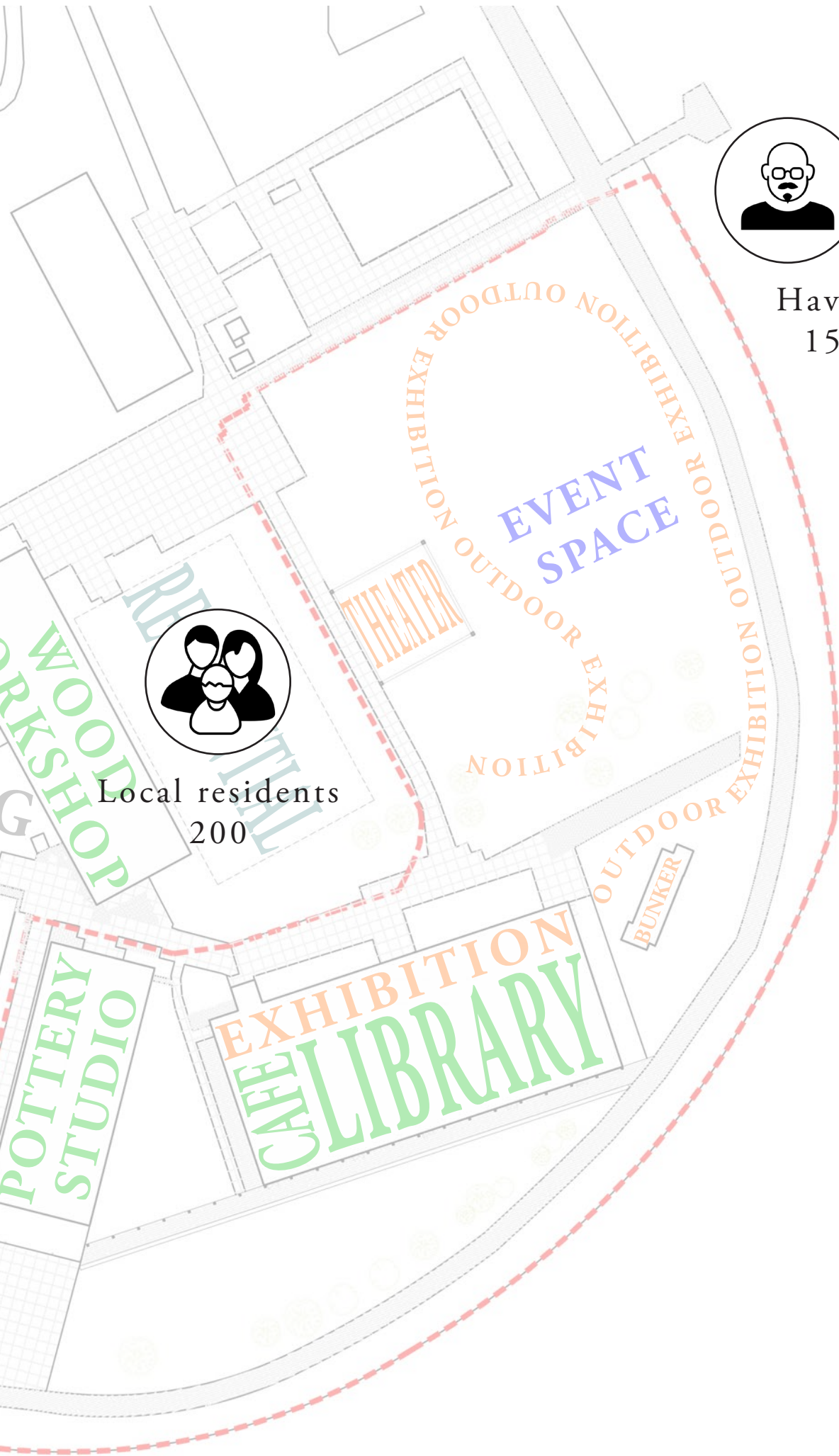

Local residents  
200





# PRODUCER, CONSUMER AND PROSUMER DISTRIBUTION



-  *Consumer*
-  *Producer*
-  *Prosumer*

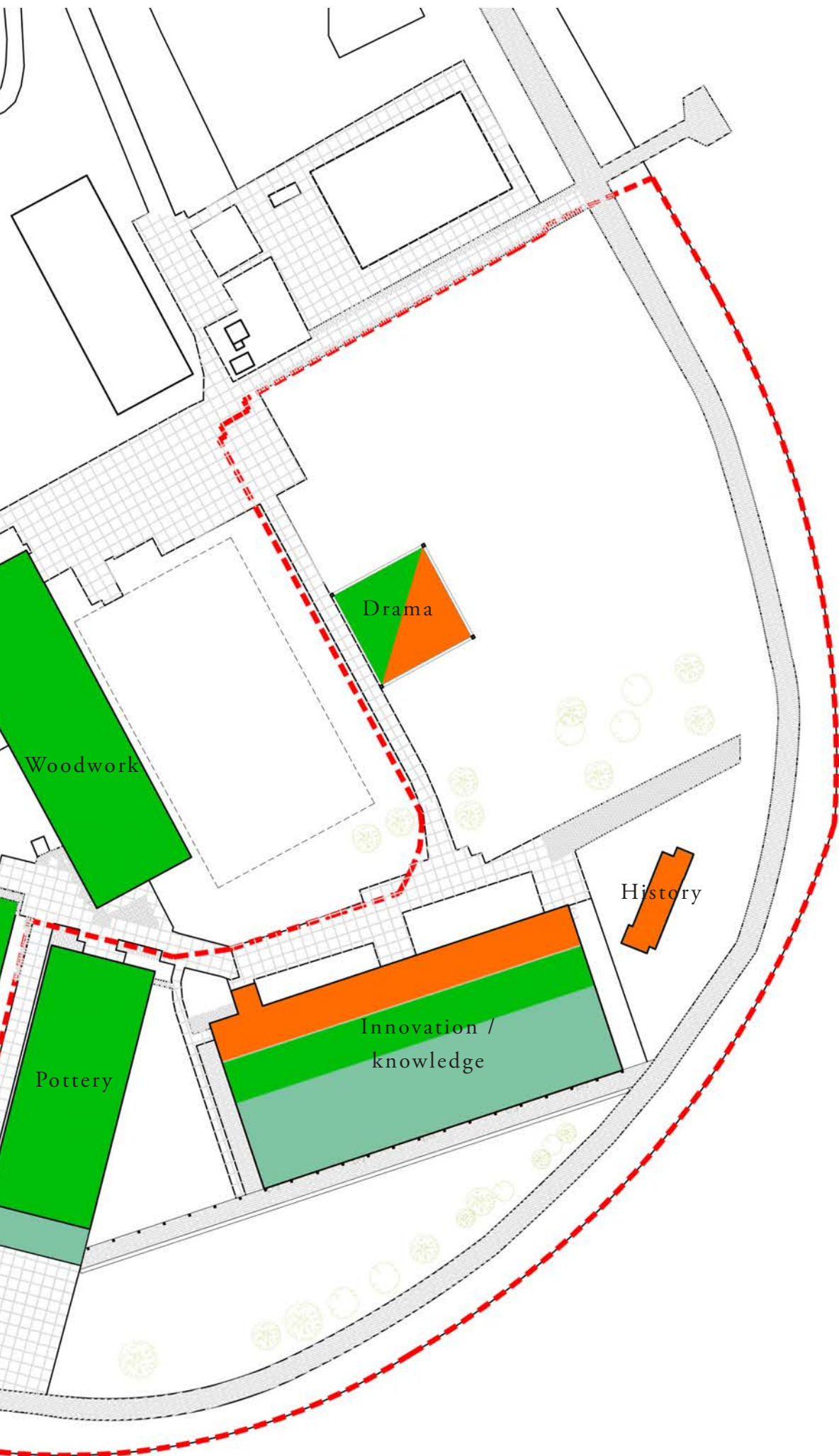



# CIRCULATION DIAGRAMS-VISITORS

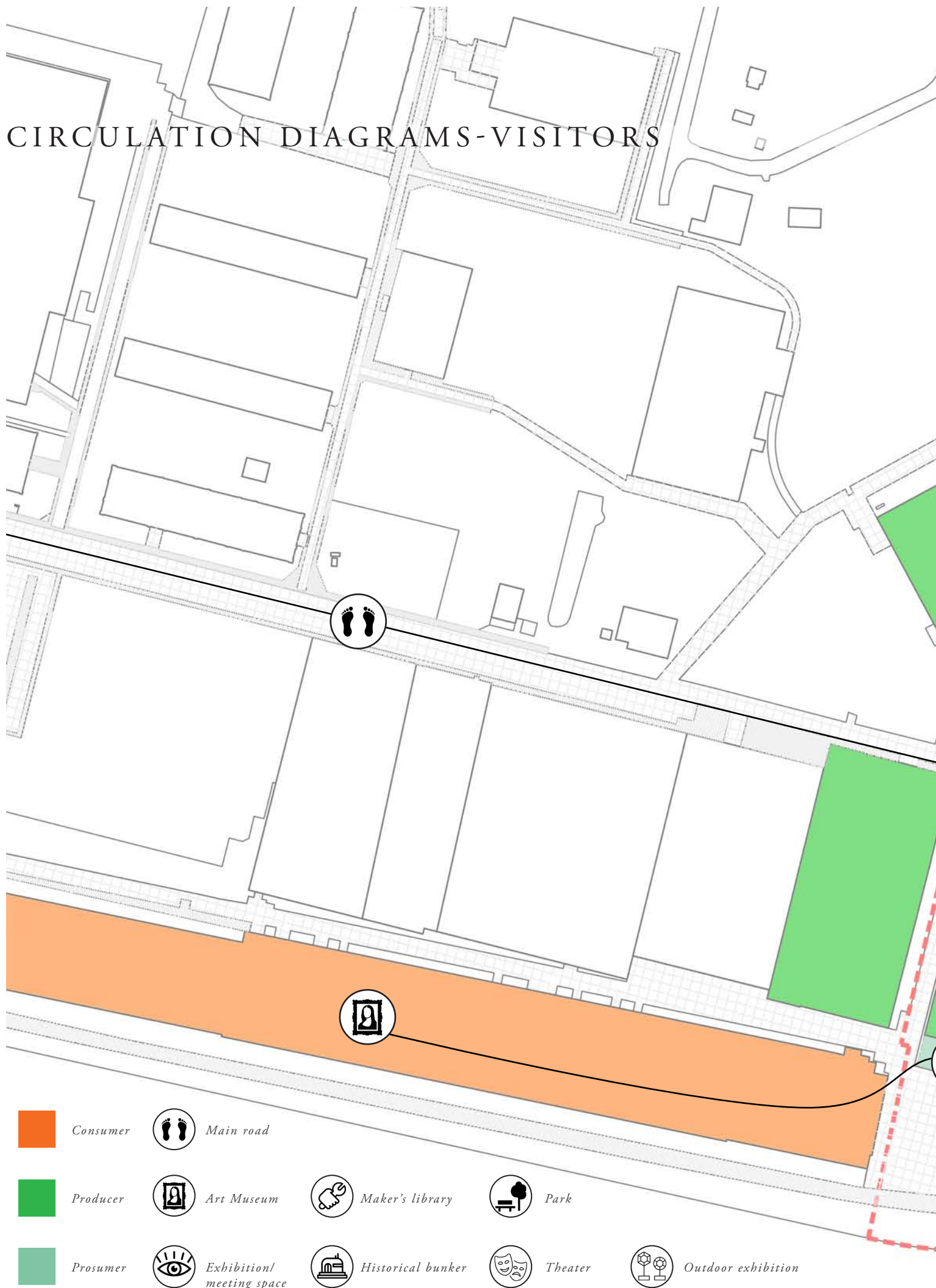



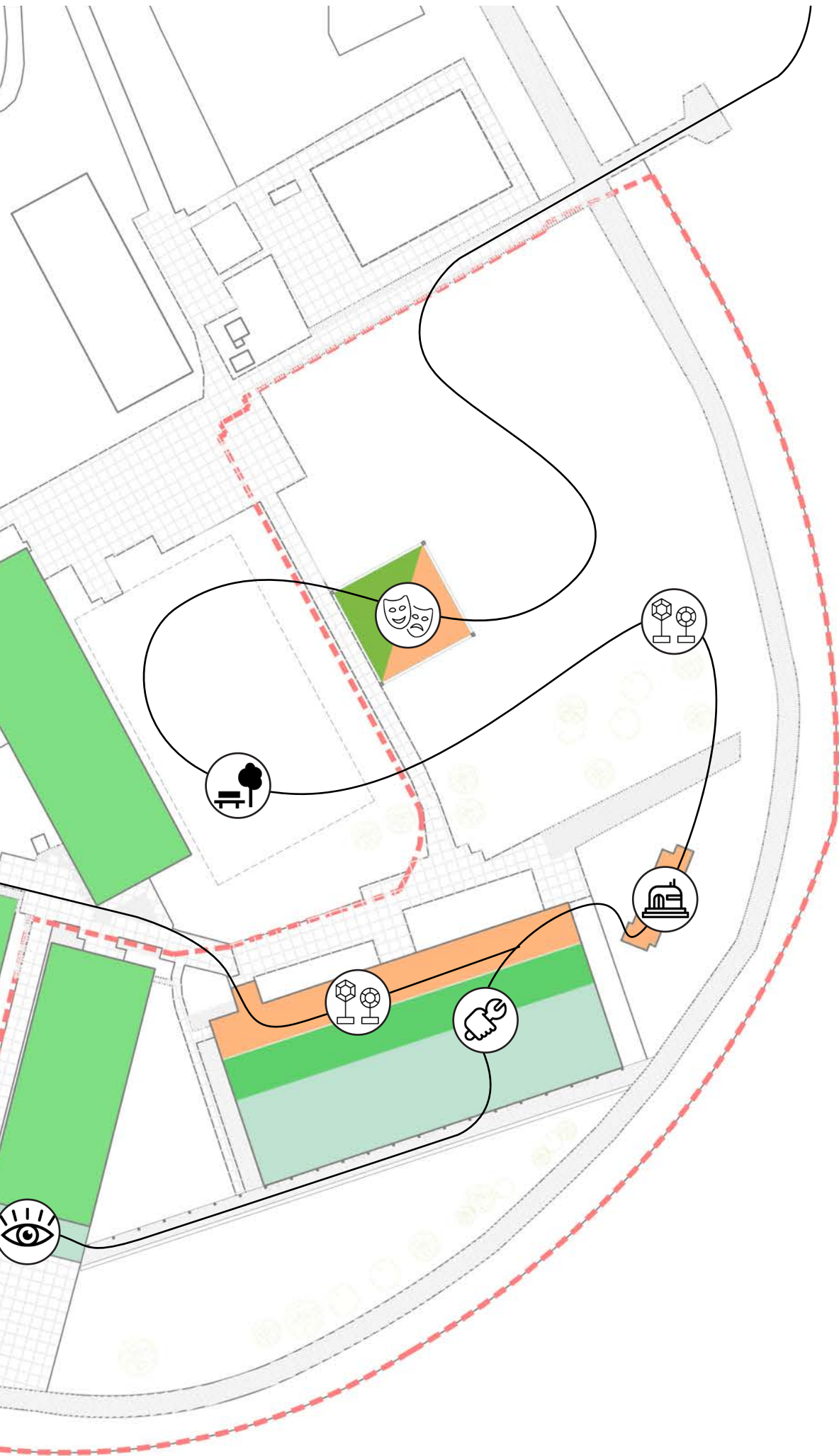

# CIRCULATION DIAGRAMS-ARTISTS



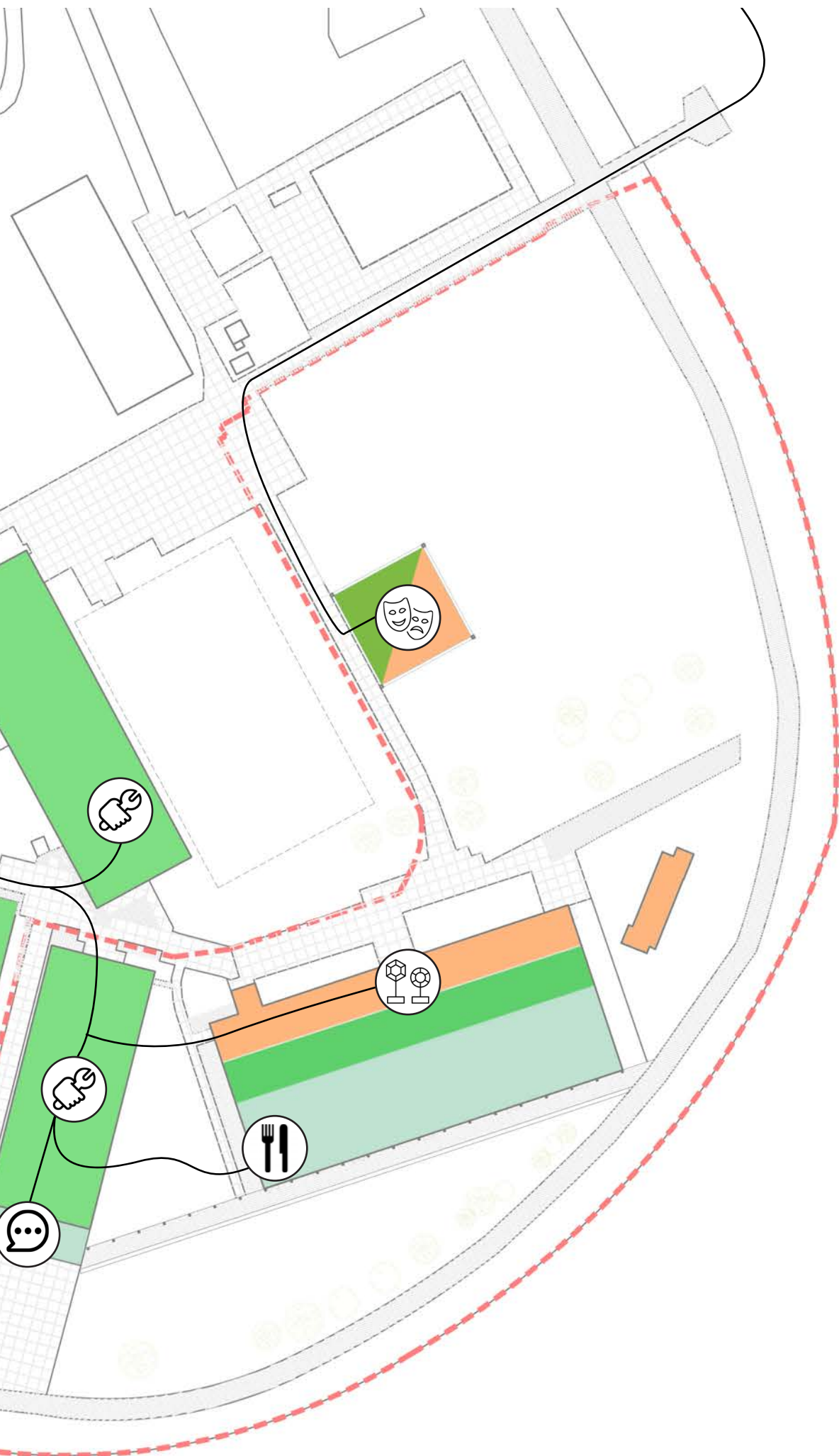



# CIRCULATION DIAGRAMS-RESIDENTS



 *Consumer*  *Bicycle lane*

 *Producer*  *Car lane*  *Atelier*  *Outdoor exhibition*

 *Prosumer*  *Parking space*  *Food Laboratory*  *Theater*

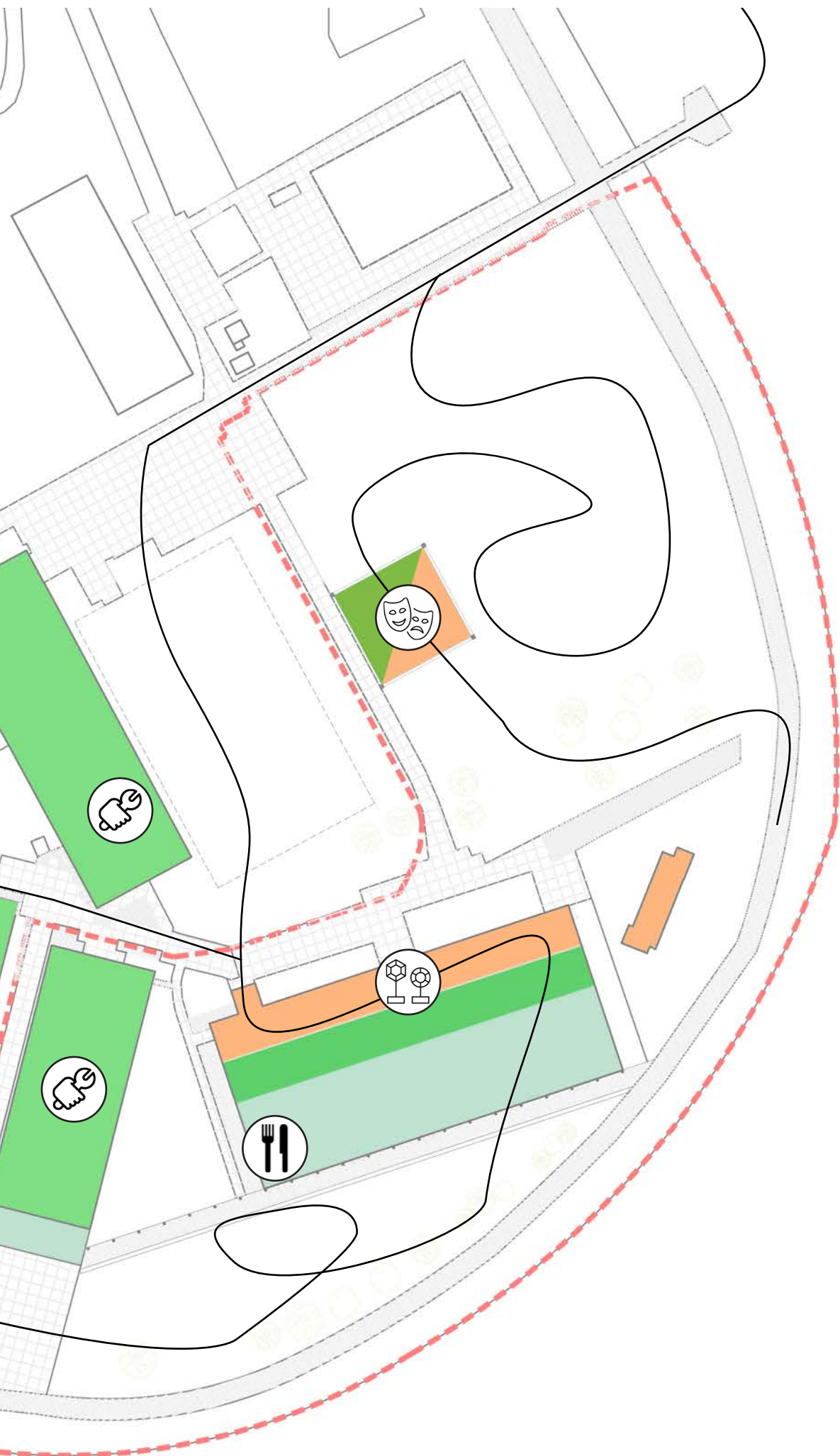

# PLANS-INNOVATION FACTORY

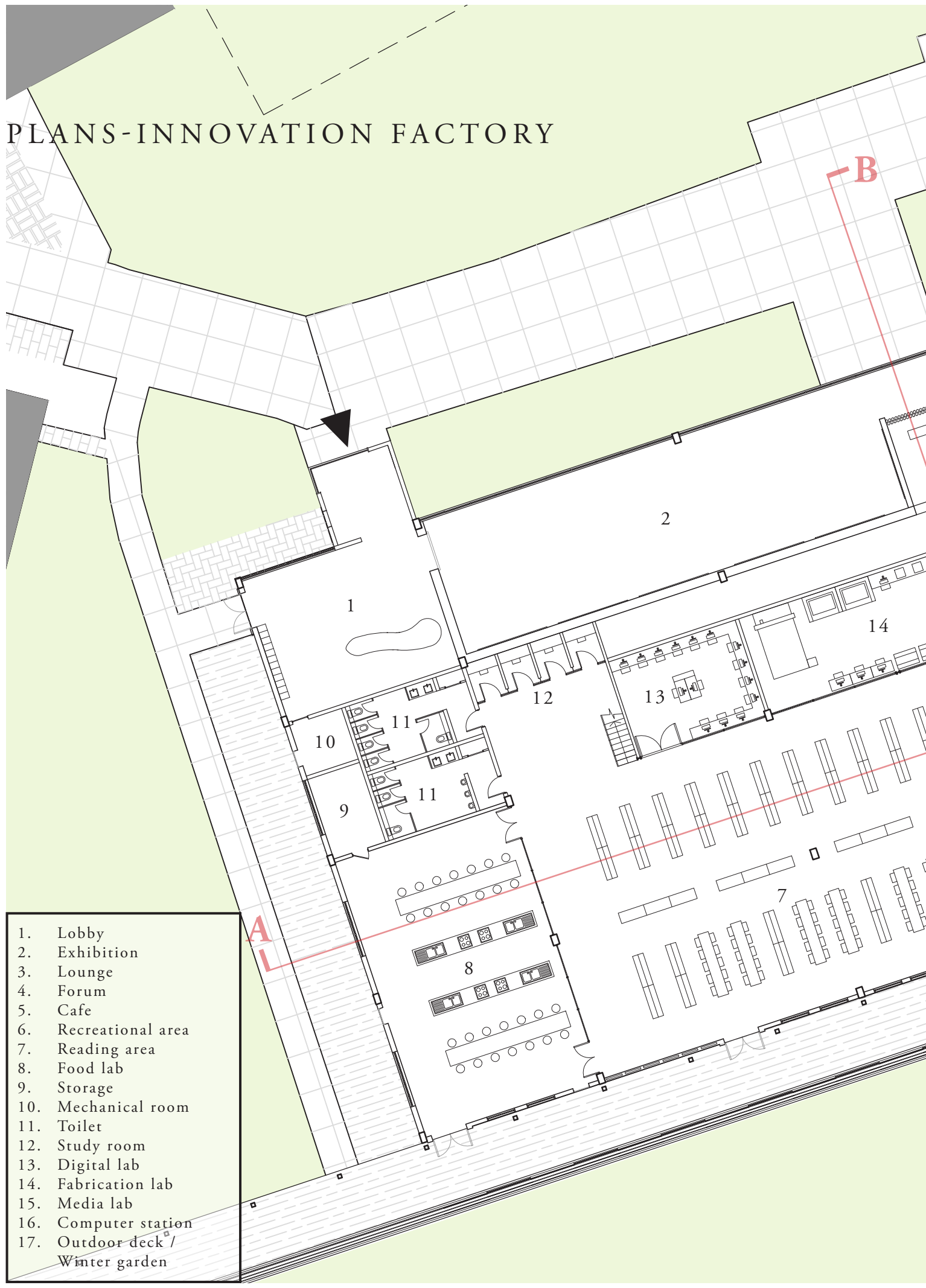

1. Lobby
2. Exhibition
3. Lounge
4. Forum
5. Cafe
6. Recreational area
7. Reading area
8. Food lab
9. Storage
10. Mechanical room
11. Toilet
12. Study room
13. Digital lab
14. Fabrication lab
15. Media lab
16. Computer station
17. Outdoor deck / Winter garden





*Innovation Factory - Ground Plan*





- 1. Lounge
- 2. Study rooms
- 3. Meeting rooms
- 4. Forum

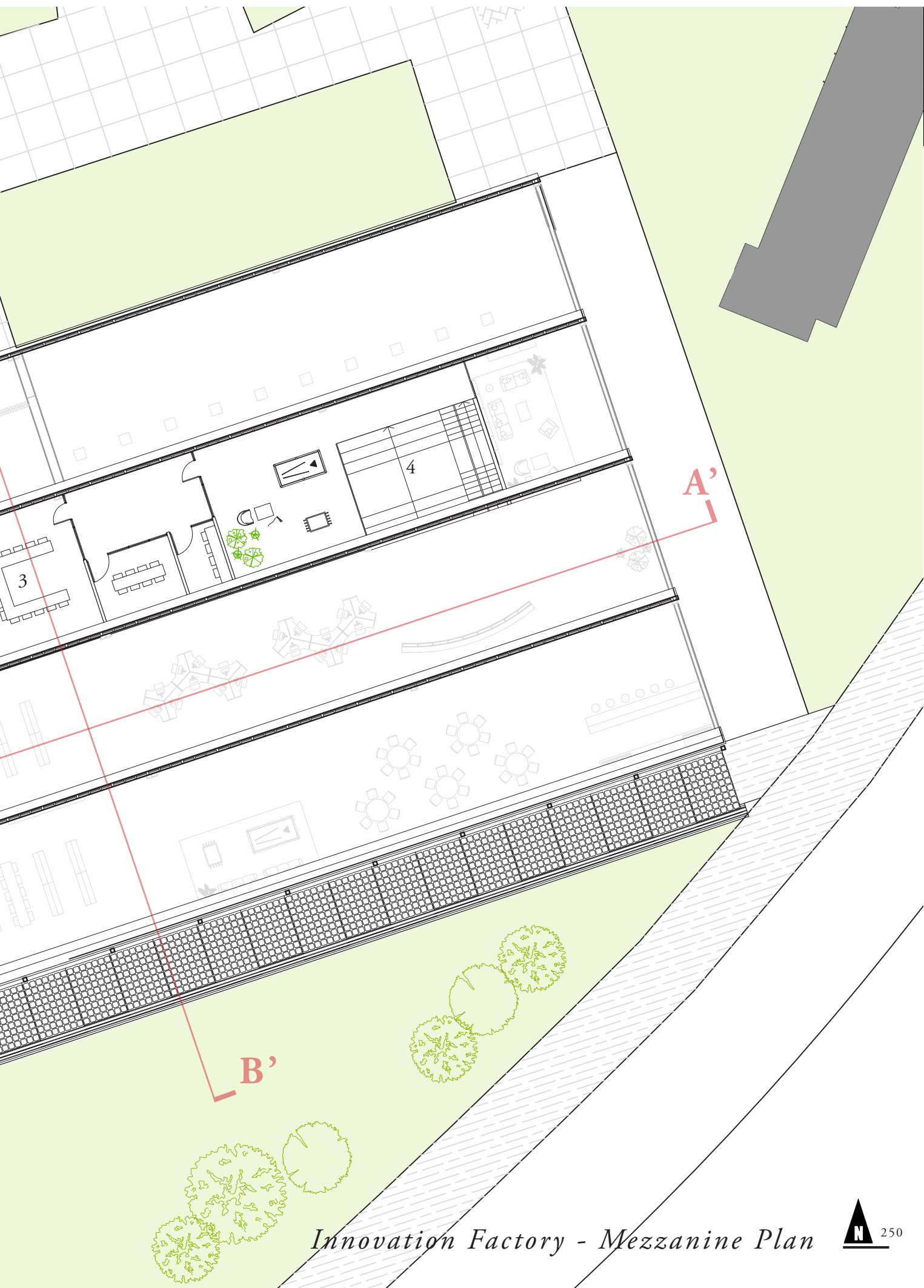

*Innovation Factory - Mezzanine Plan*





# SECTIONS-INNOVATION FACTORY

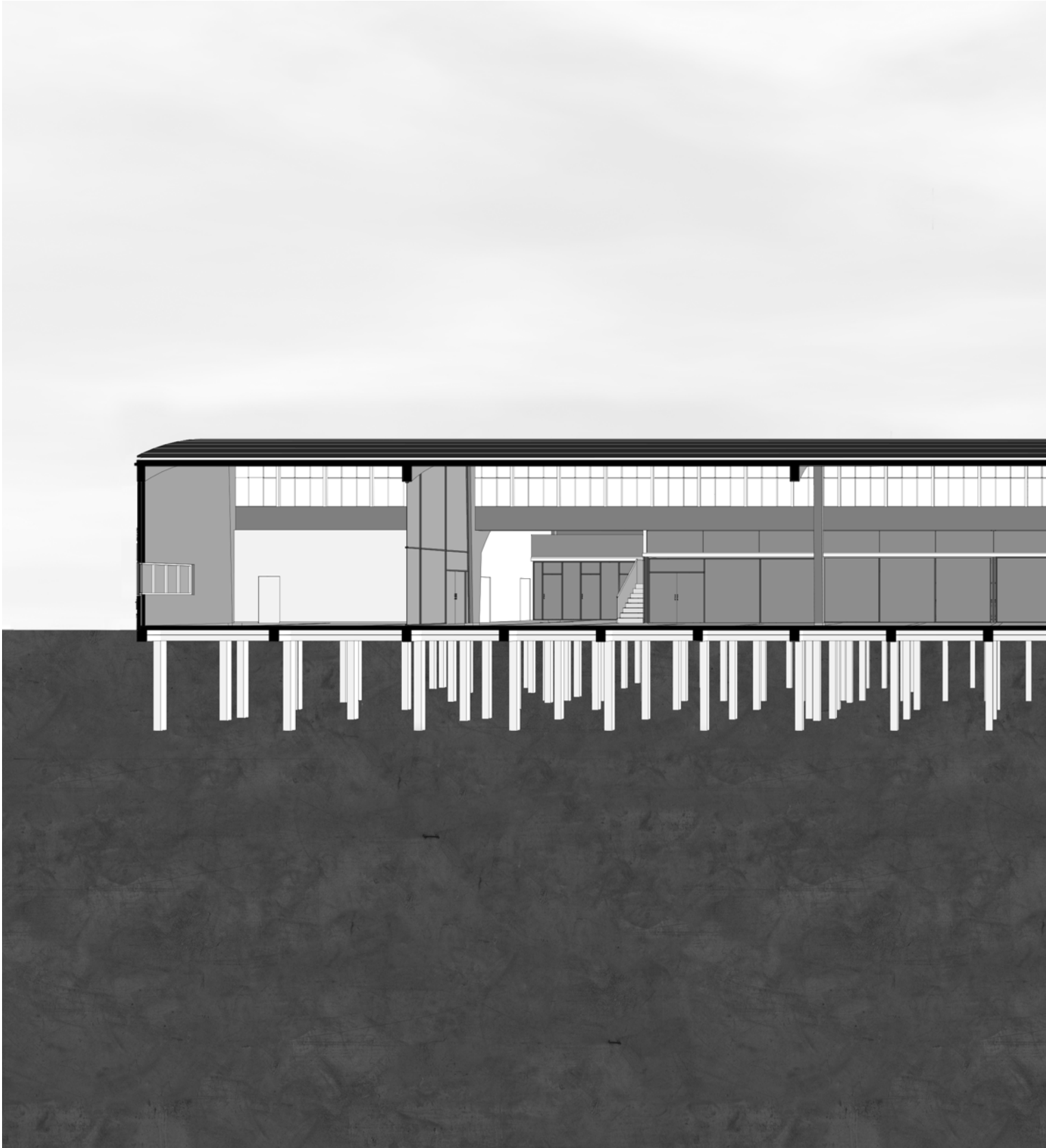



*Innovation Factory - Section A-A' 1:200*

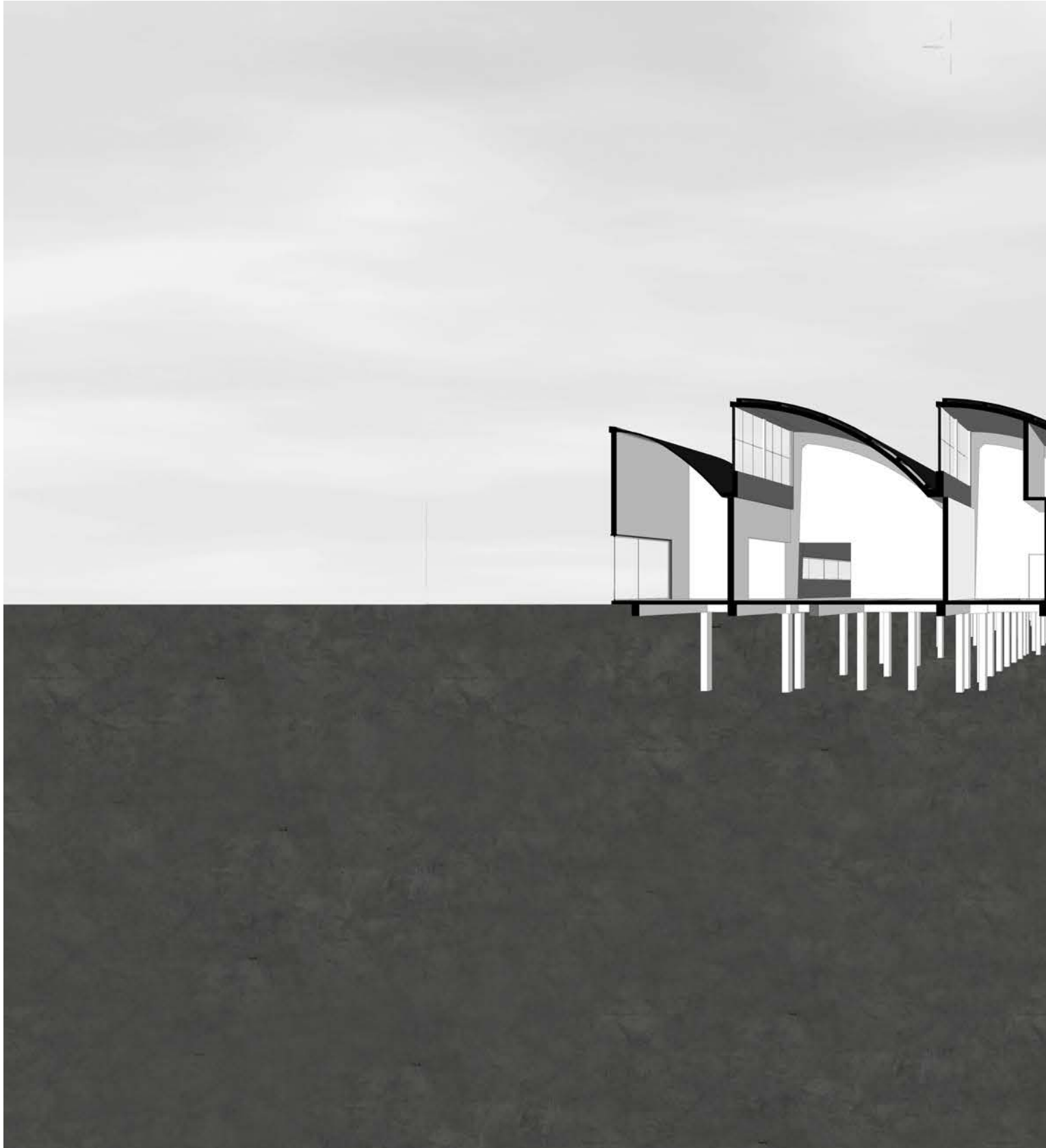





*Innovation Factory - Section B-B' 1:200*

# ELEVATIONS-INNOVATION FACTORY

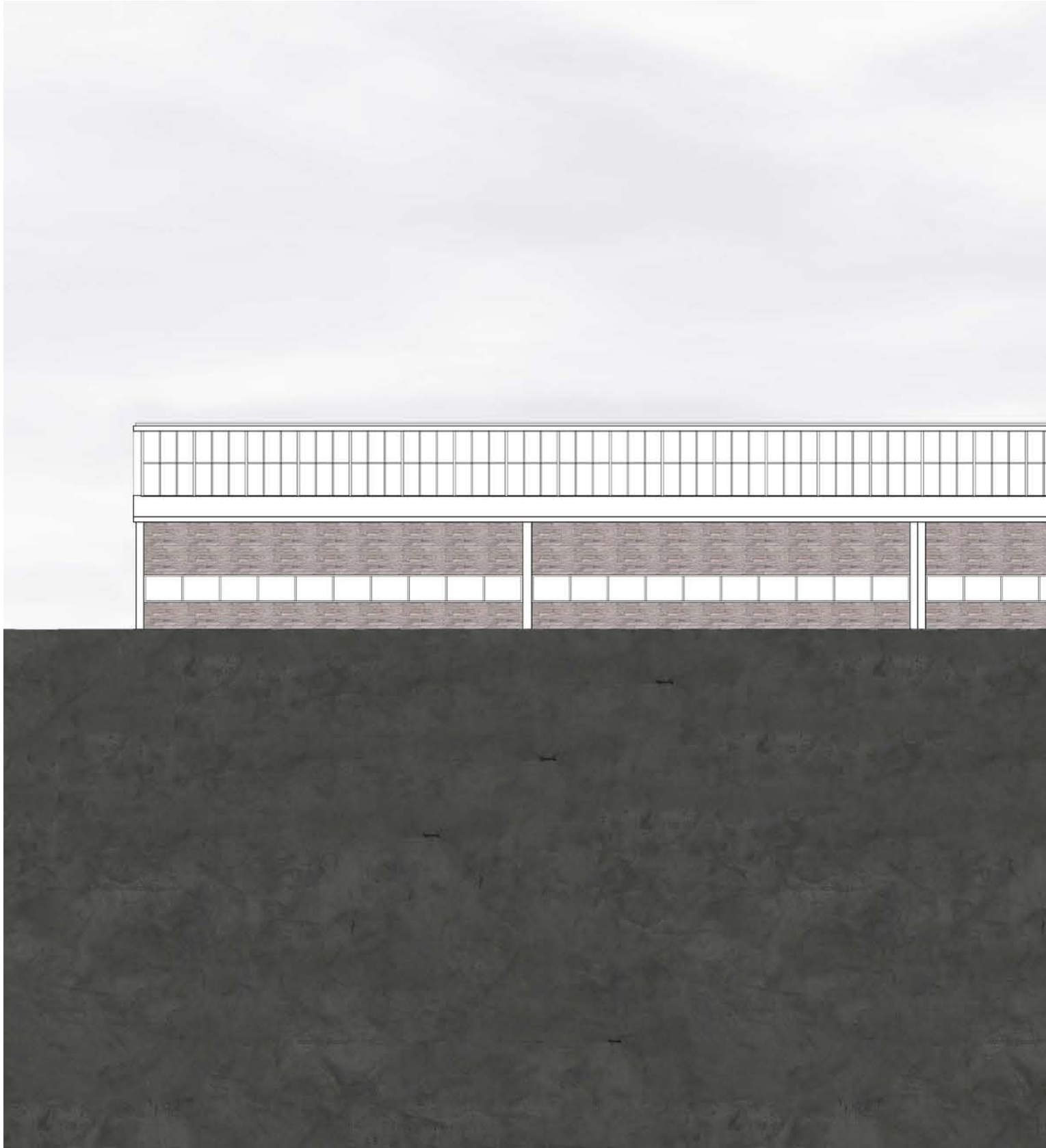



*Innovation Factory - North elevation 1:200*



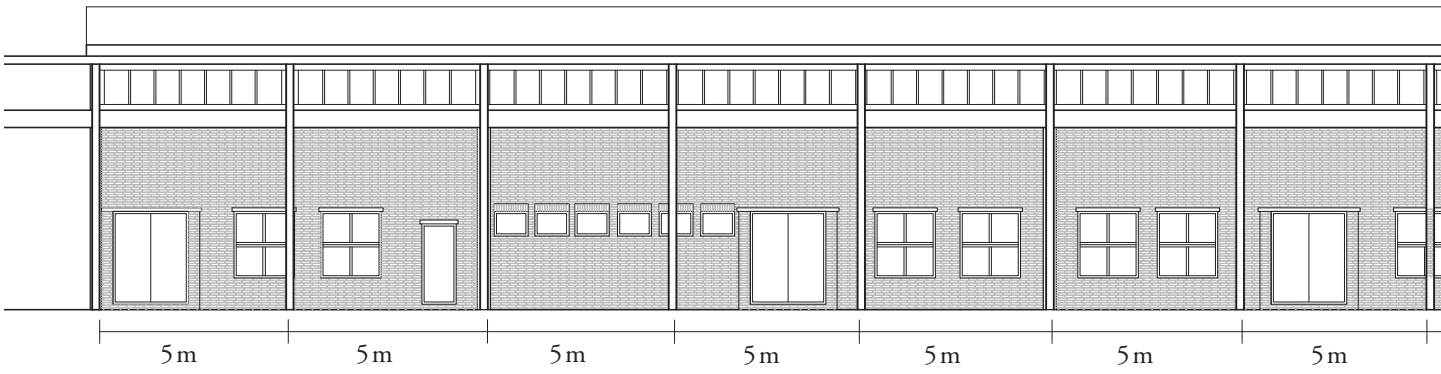
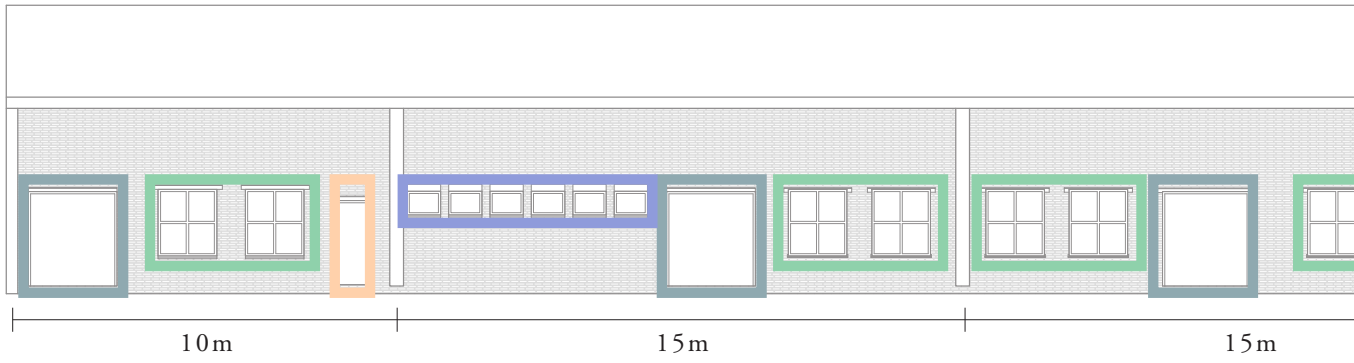

Rhythm



Symmetry

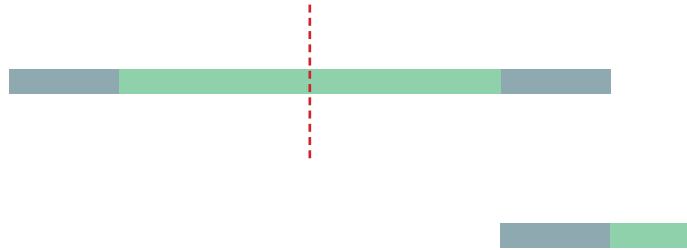



Innovation Factory - Original South elevation 1:200



Innovation Factory - New South elevation 1:200

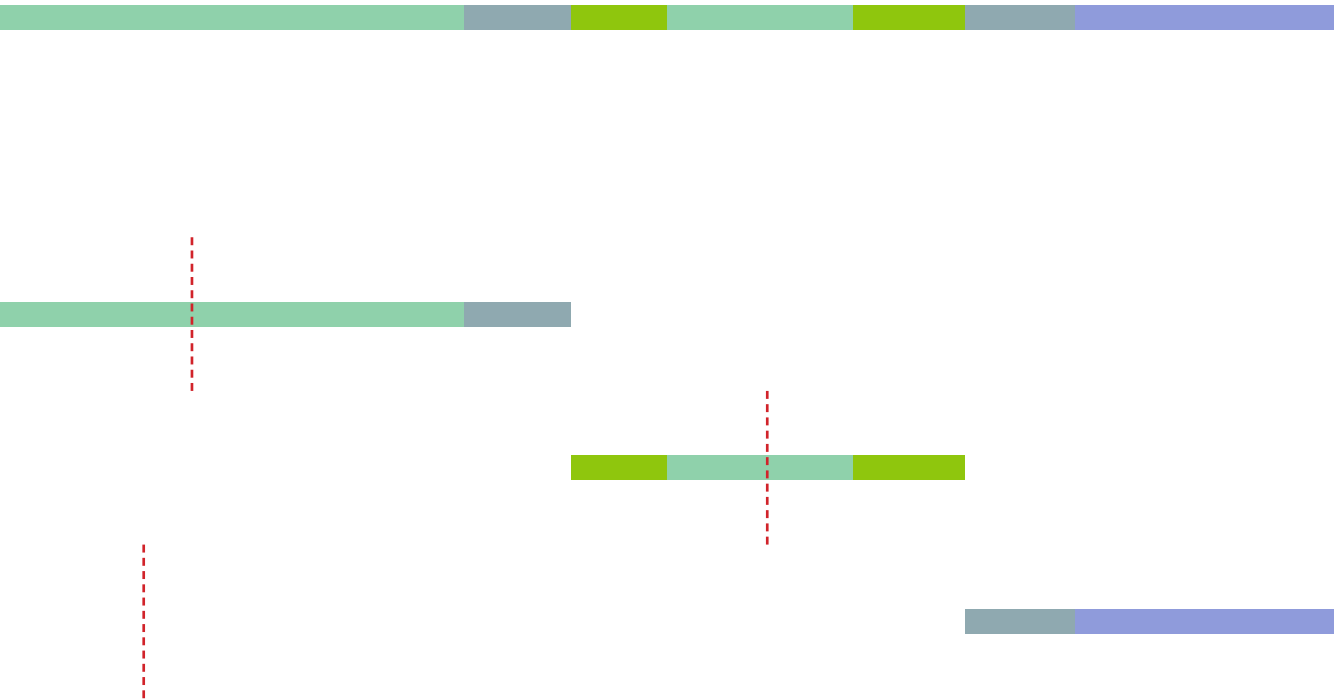

# PLAN-POTTERY STUDIO

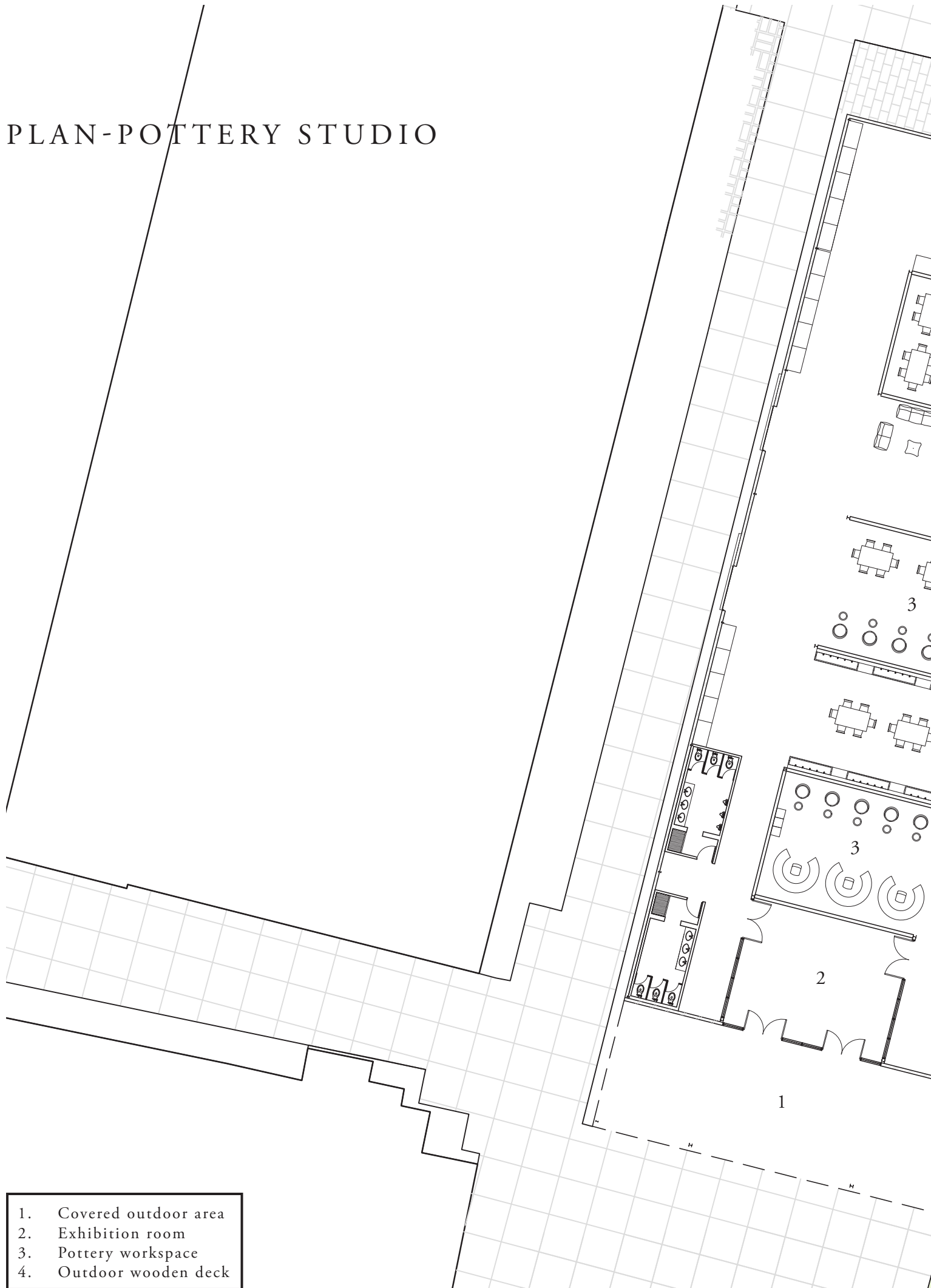

- 1. Covered outdoor area
- 2. Exhibition room
- 3. Pottery workspace
- 4. Outdoor wooden deck





Pottery Studio - Ground Plan



# SECTIONS-POTTERY STUDIO

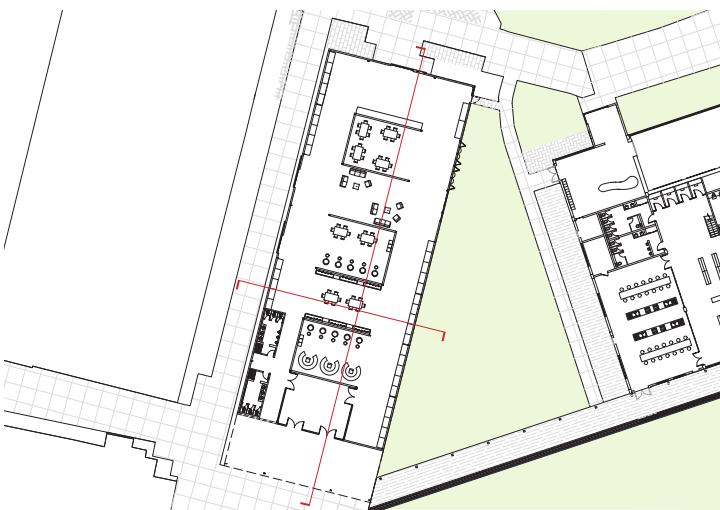
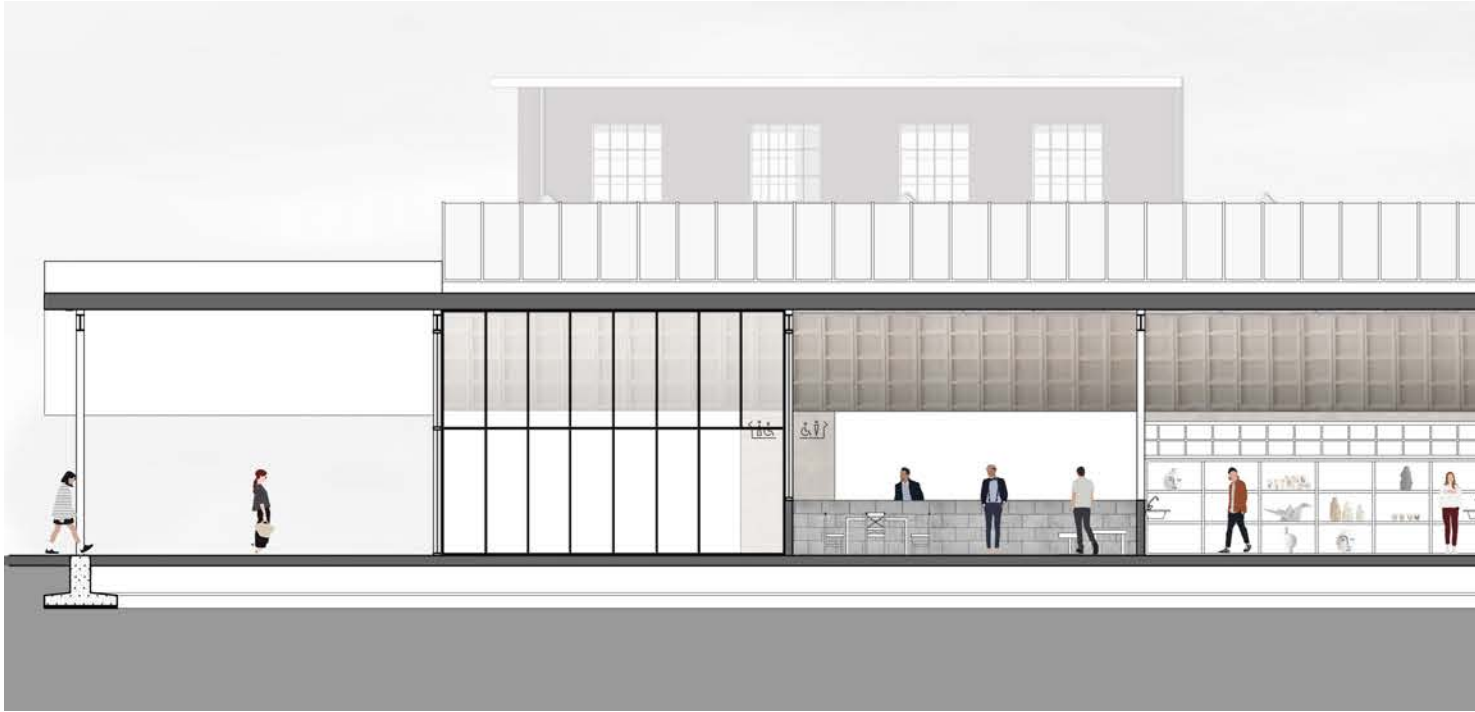



*Pottery Studio - Longitude Section 1:100*



*Pottery Studio - Latitude Section 1:100*



# RENDERINGS







*Innovation Factory - South facade*









*Innovation Factory - Summer scenario - Outdoor deck*

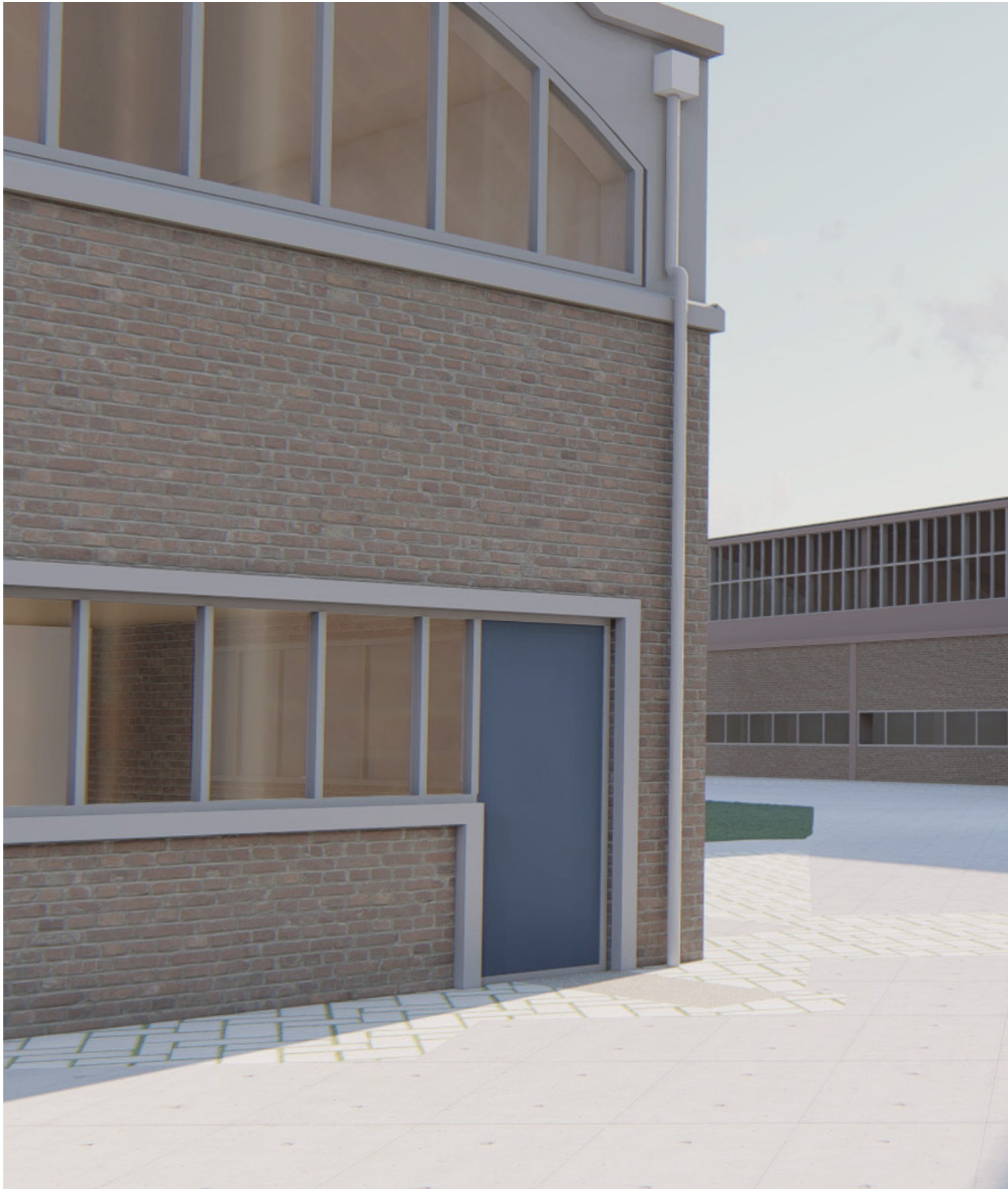





*Innovation Factory - Entrance view*







*Innovation Factory - View towards the Noordzeekanaal*



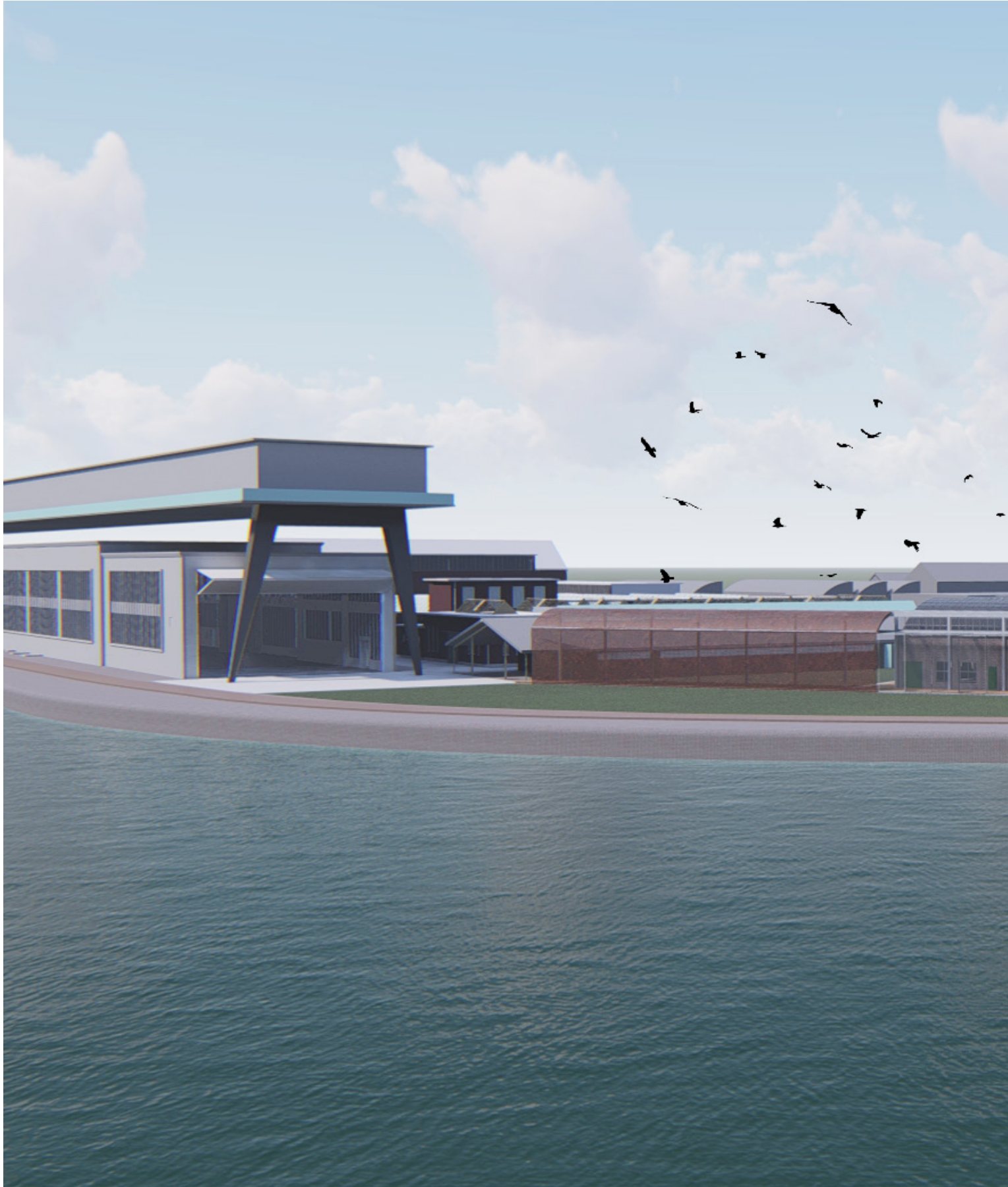





*Innovation Factory - Perspective from Noordzeekanaal, day time*





*Innovation Factory - Perspective from Noordzeekanaal, night time*







*Innovation Factory - Interior - P4 products - lounge room*









*Innovation Factory - Interior - Main space*







*Innovation Factory - Interior - Mezzanine*







*Innovation Factory - Interior - Laboratories*







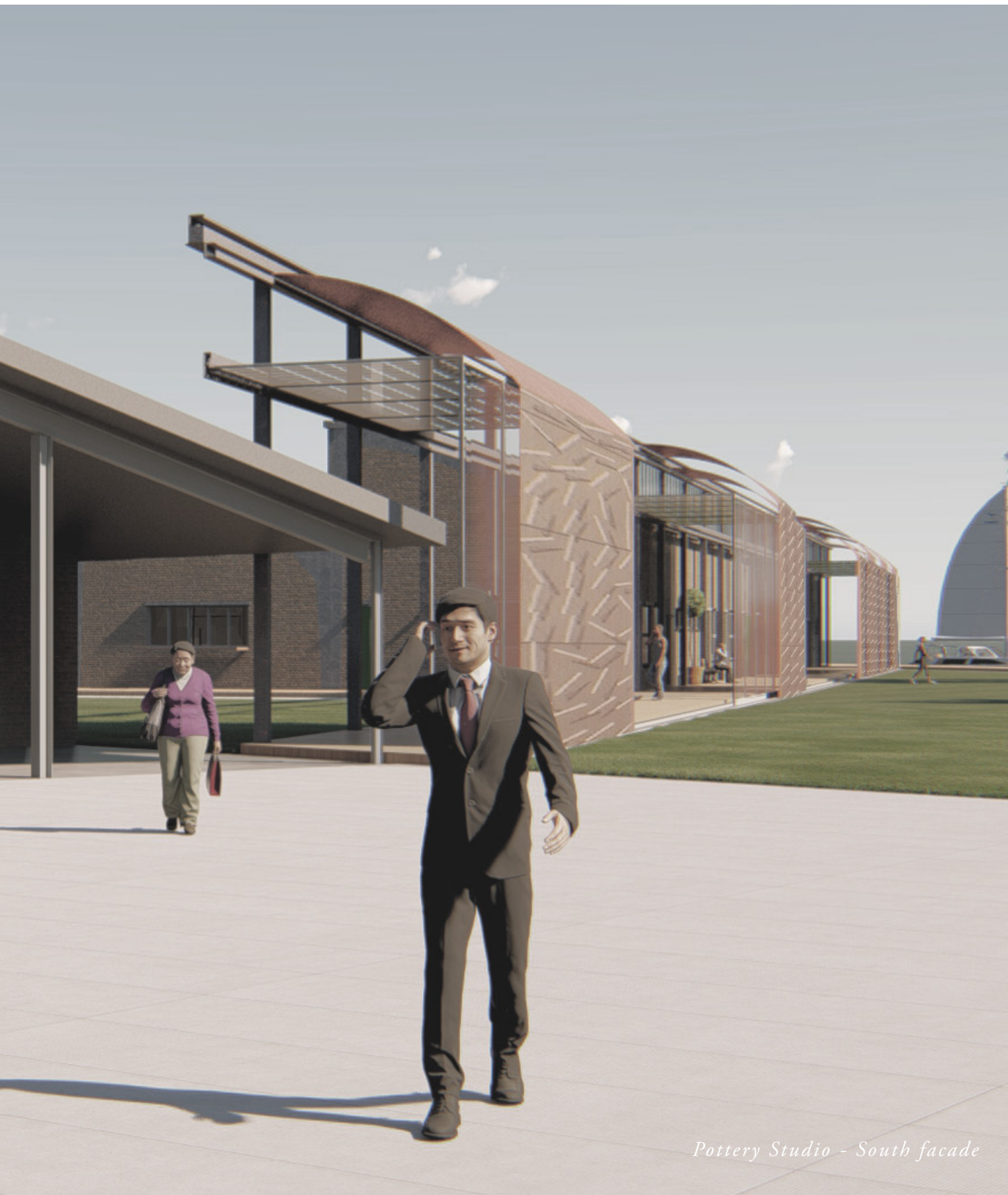

*Pottery Studio - South facade*





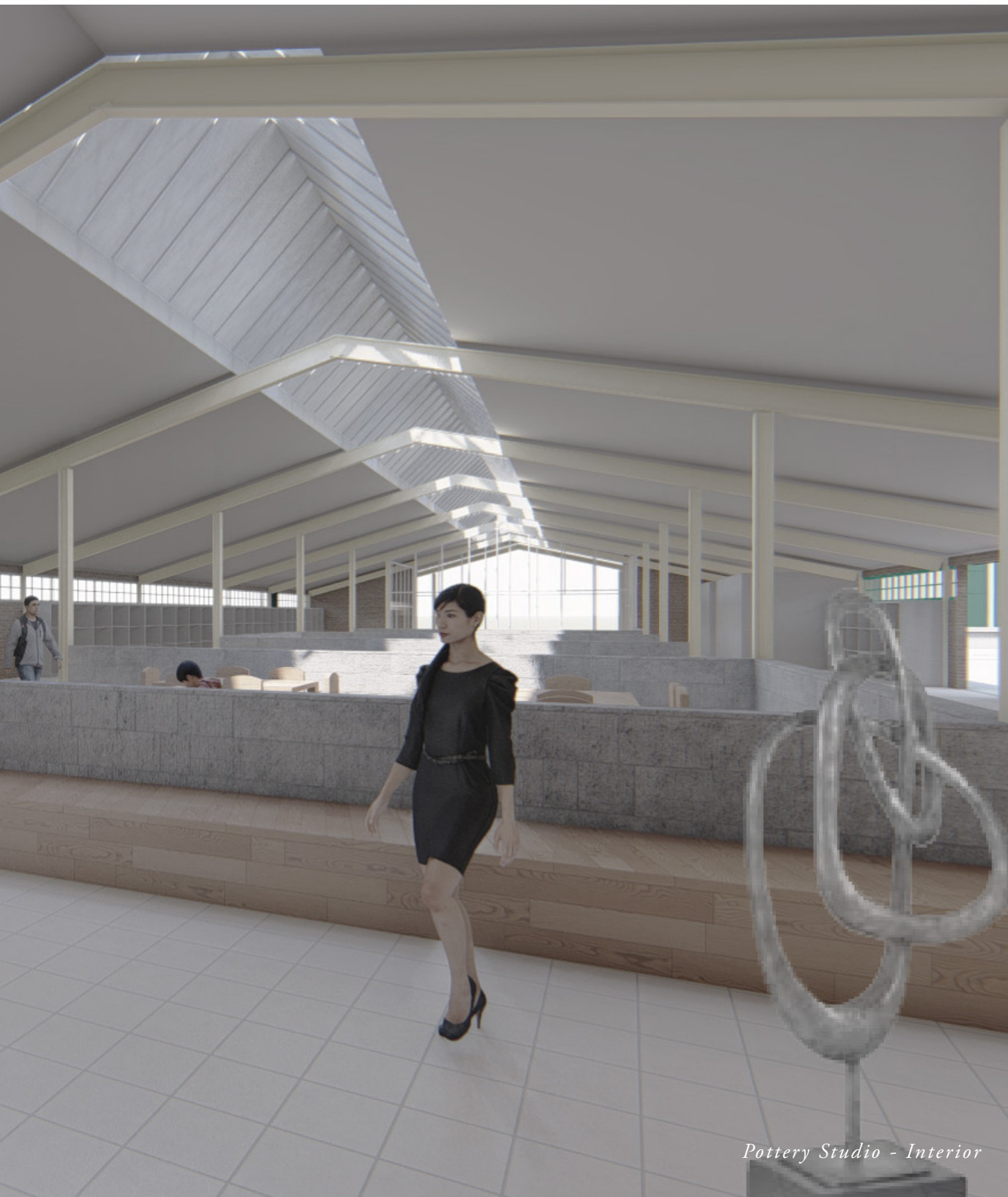

*Pottery Studio - Interior*



# CLIMATIC DIAGRAMS

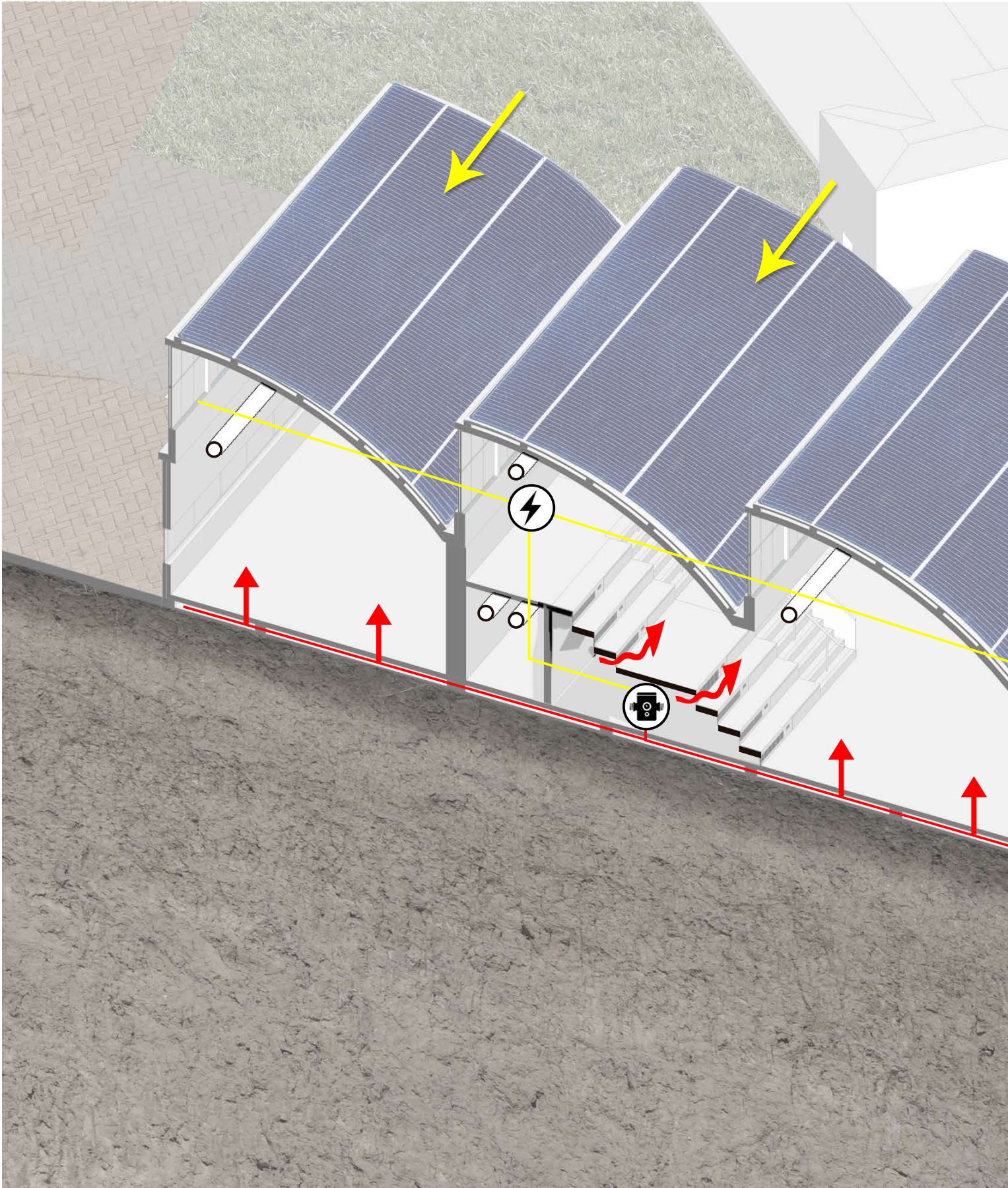



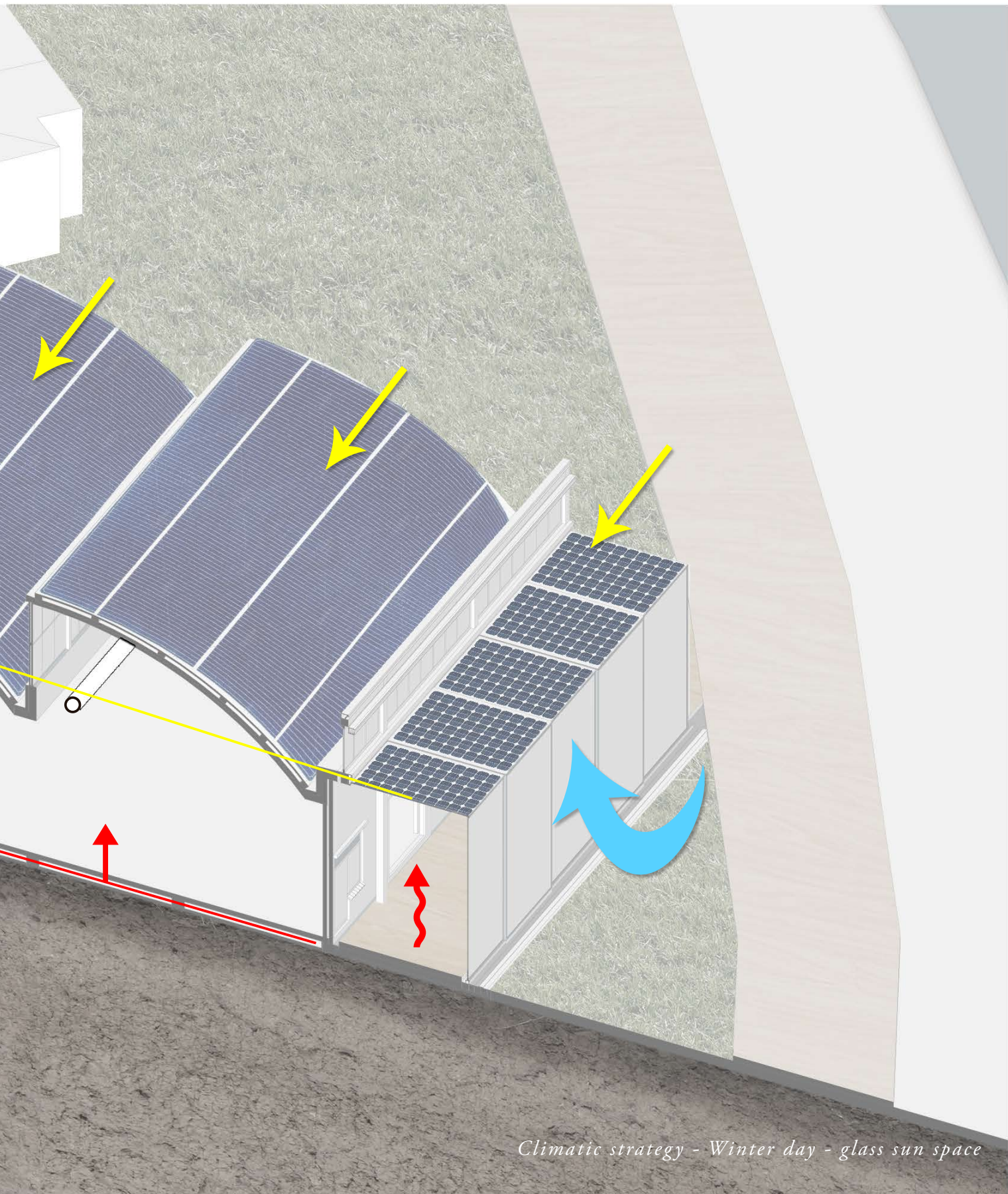

*Climatic strategy - Winter day - glass sun space*



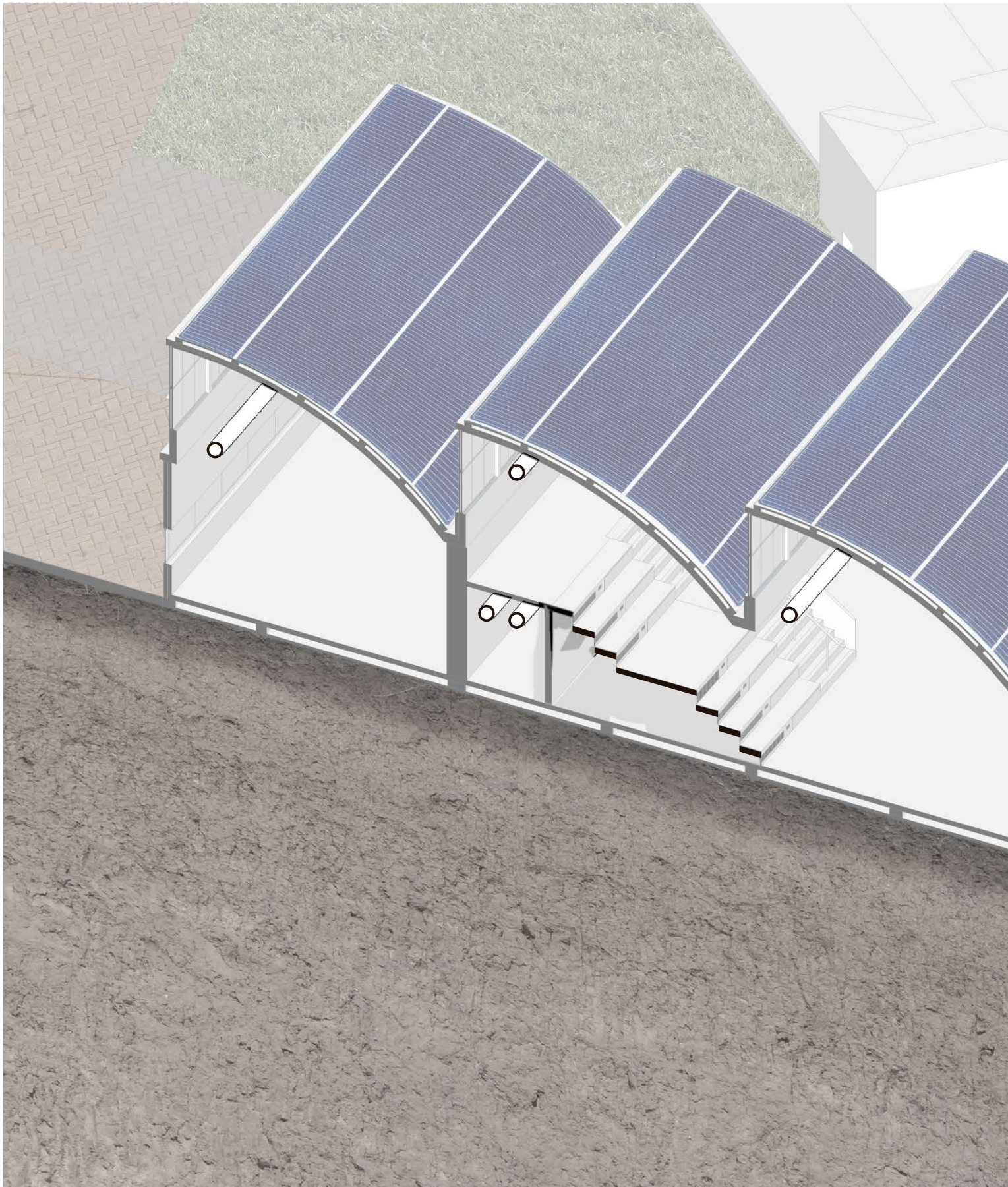



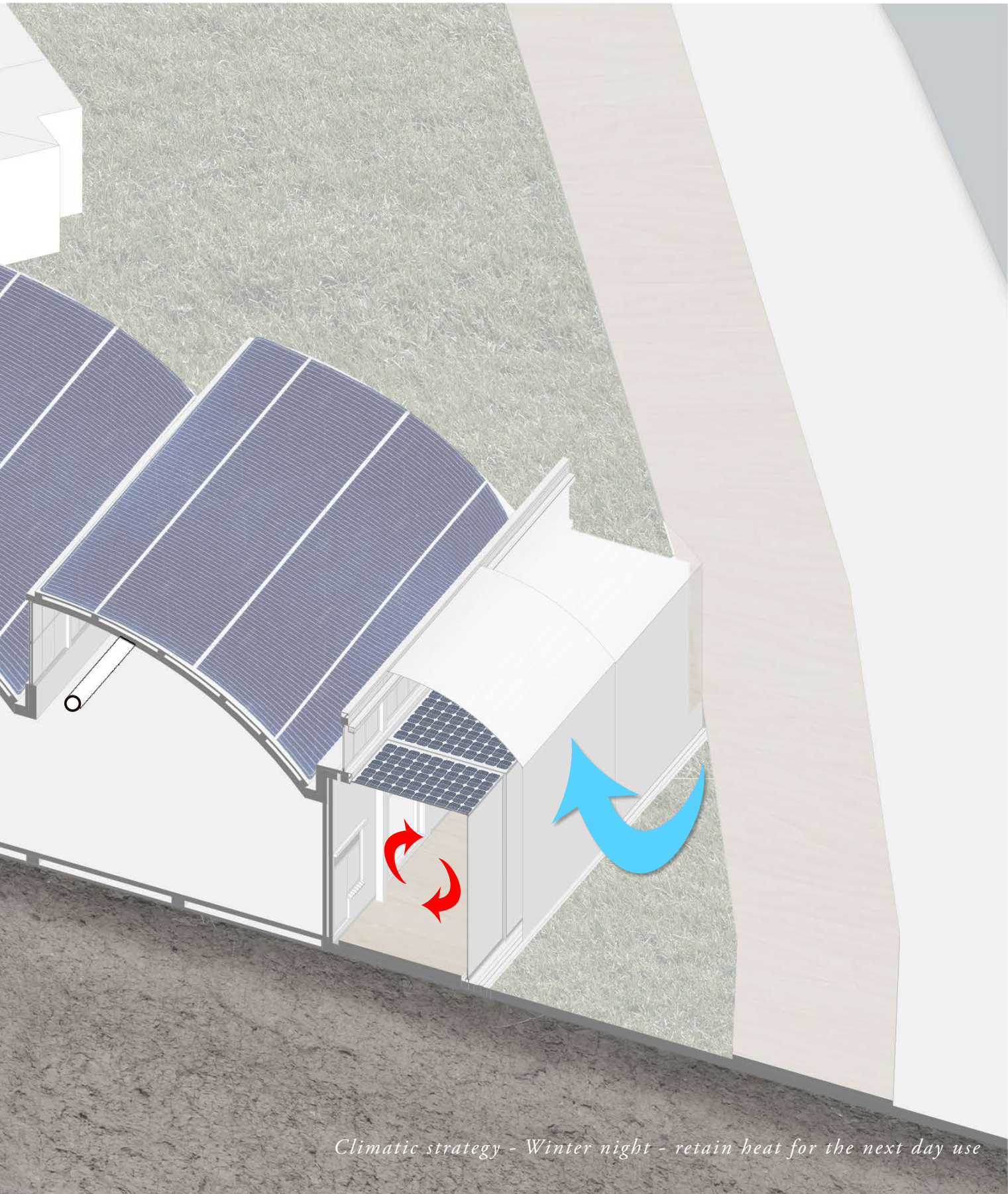

*Climatic strategy - Winter night - retain heat for the next day use*



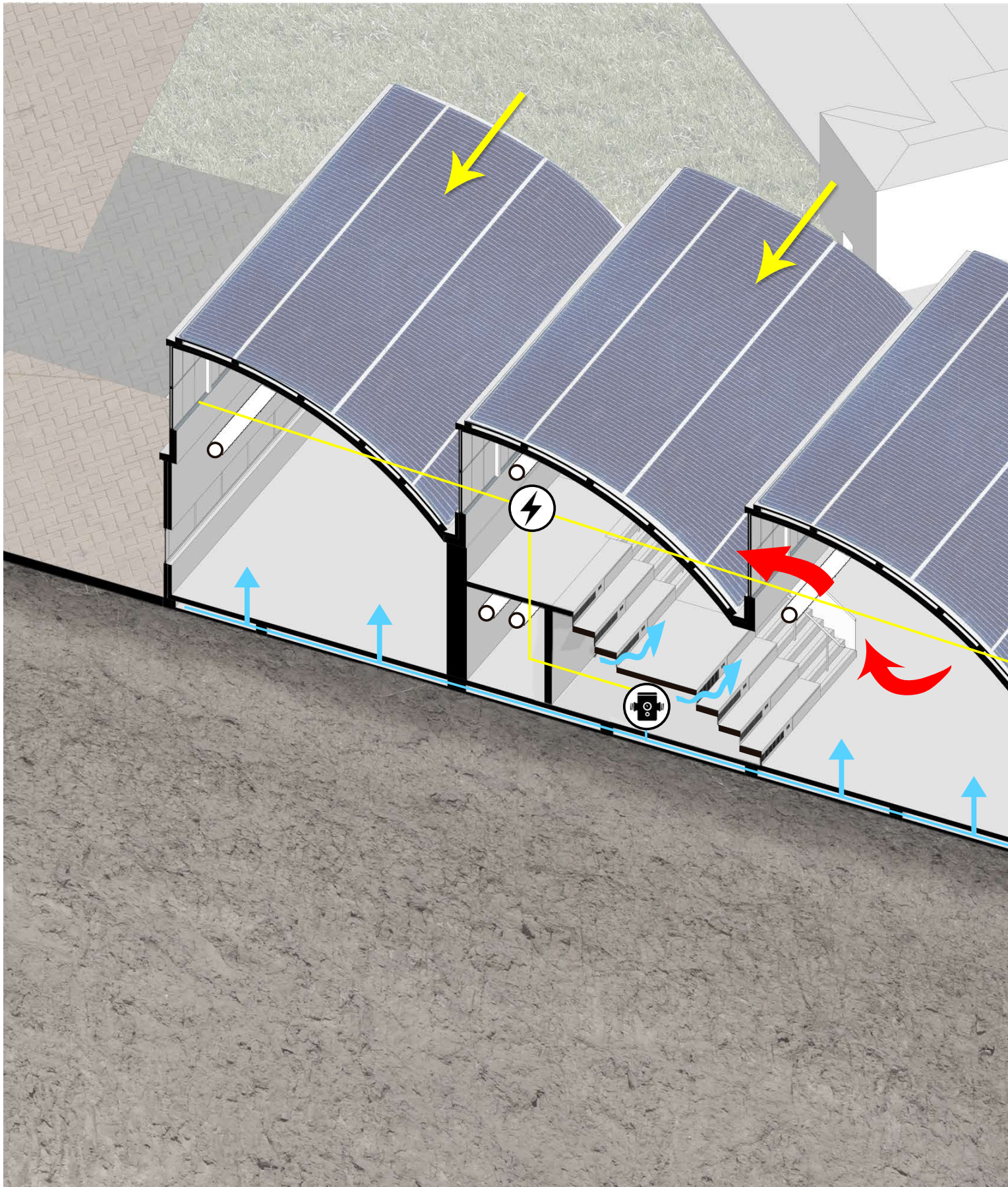



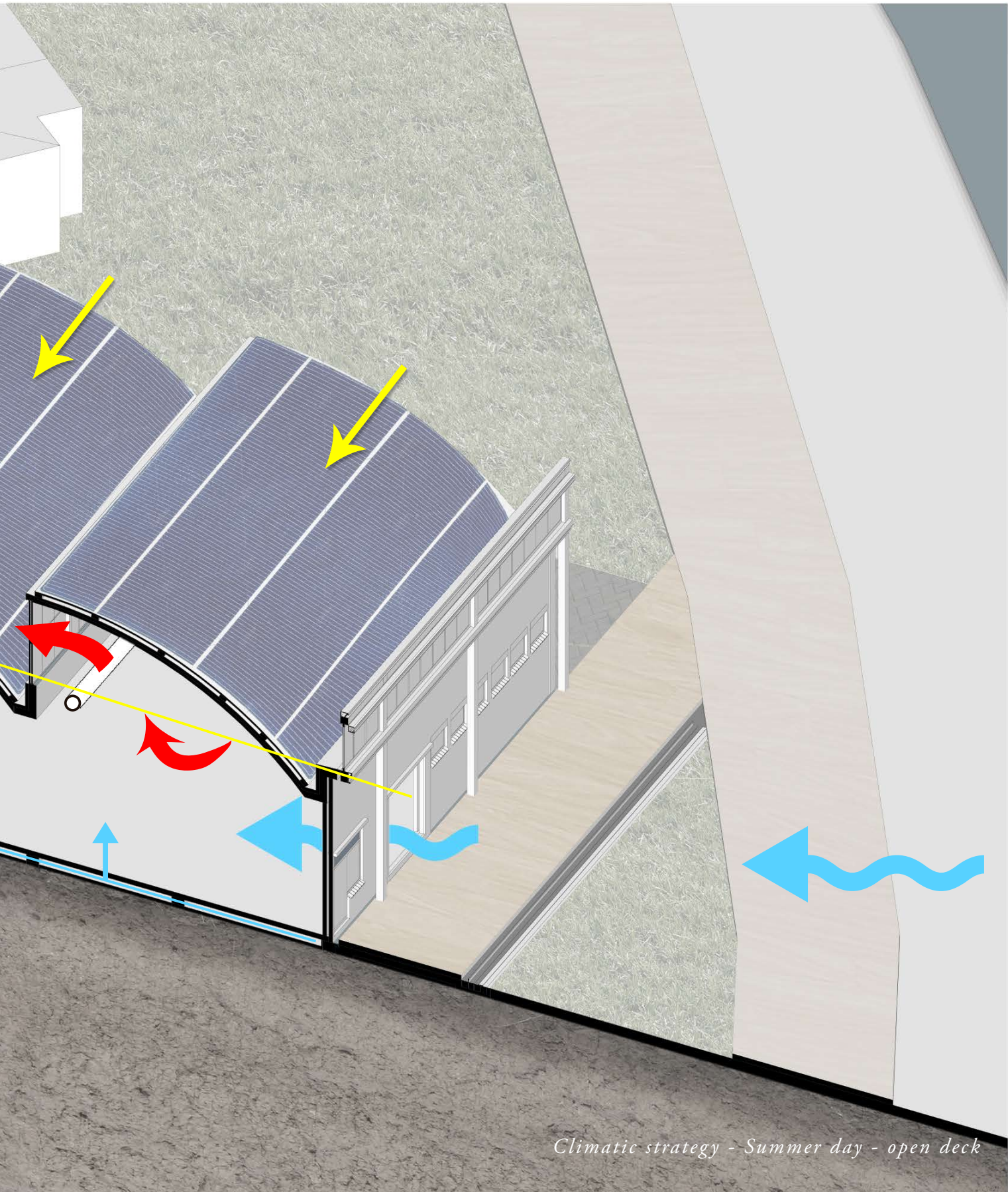

*Climatic strategy - Summer day - open deck*



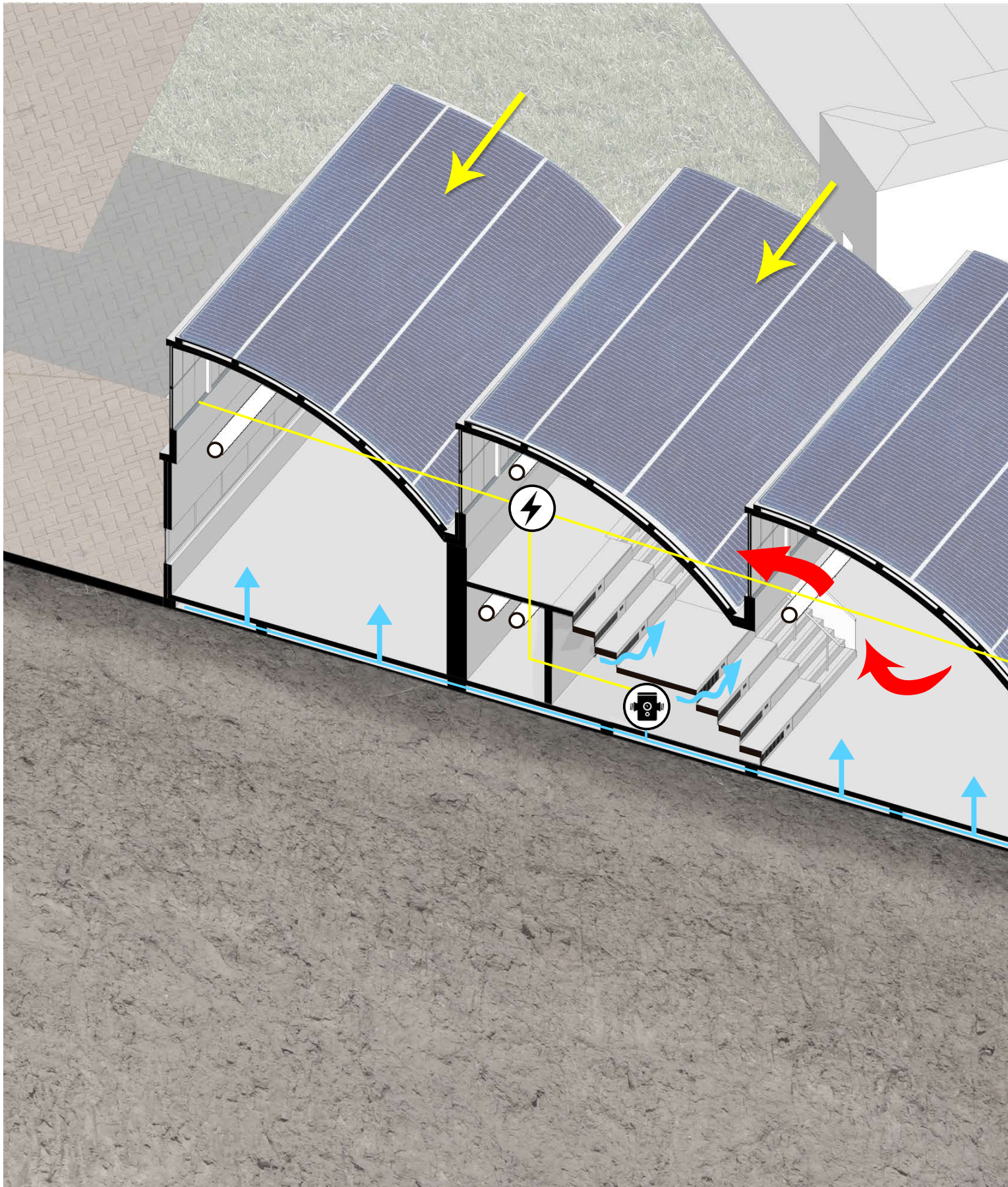



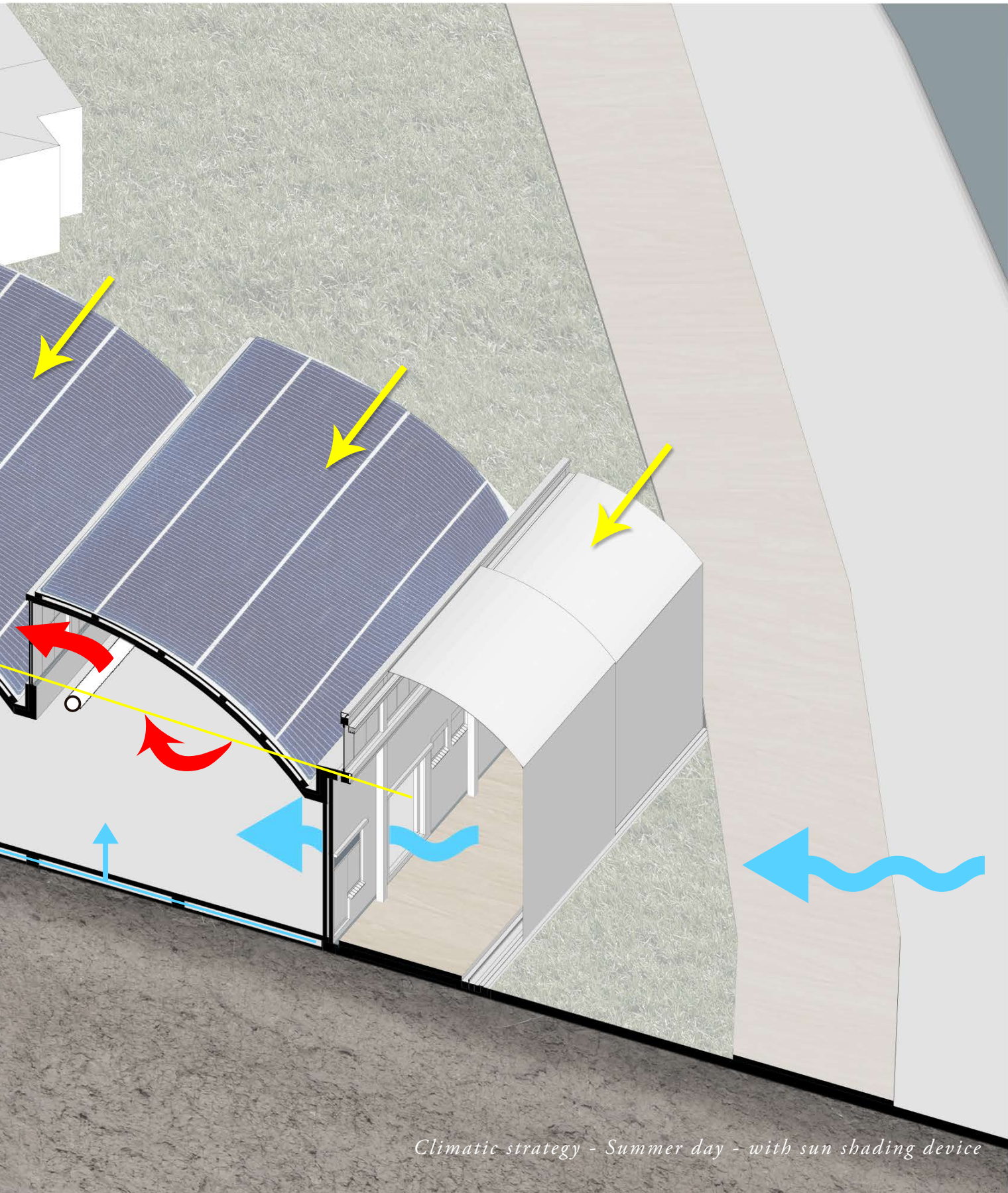

*Climatic strategy - Summer day - with sun shading device*



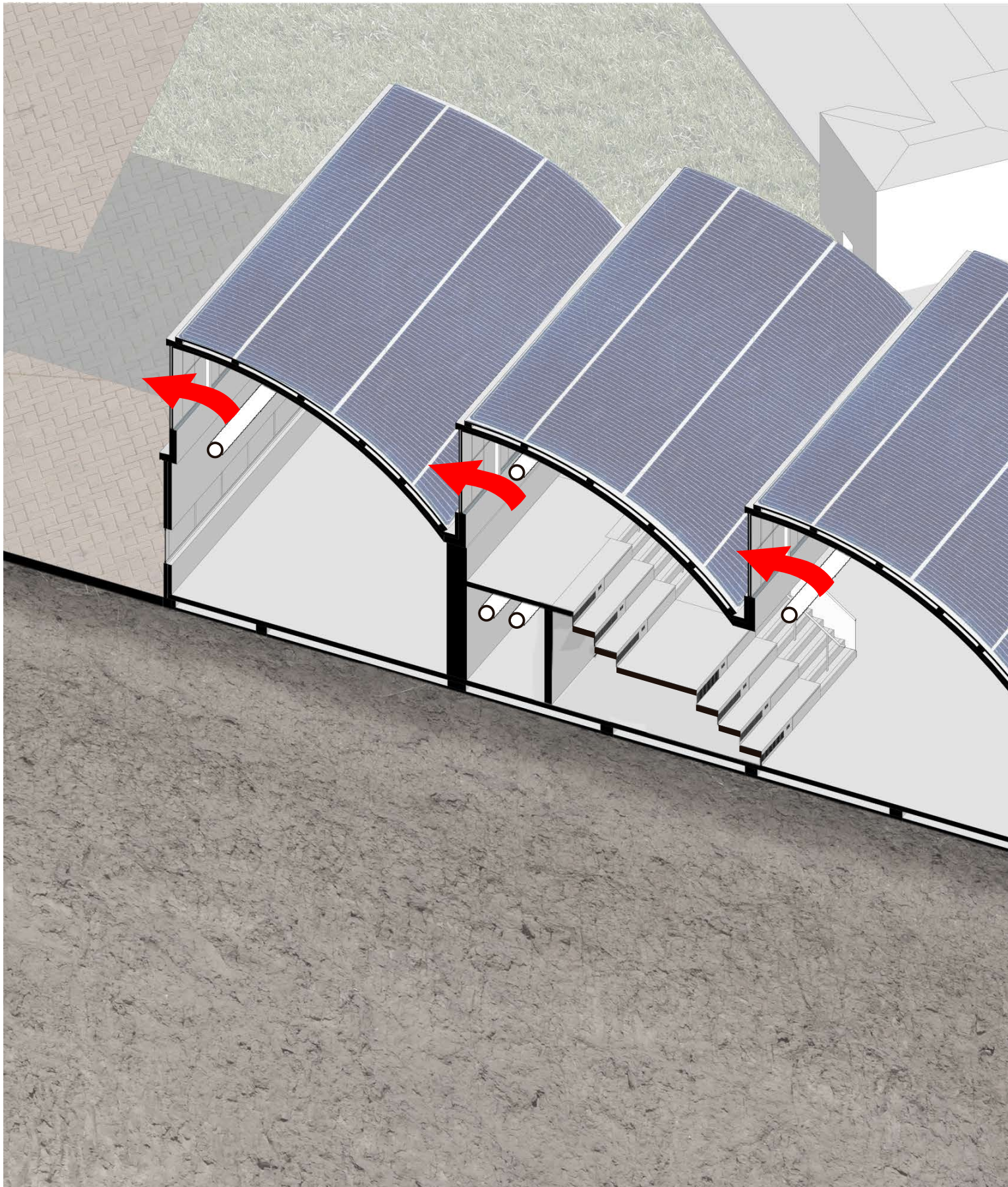



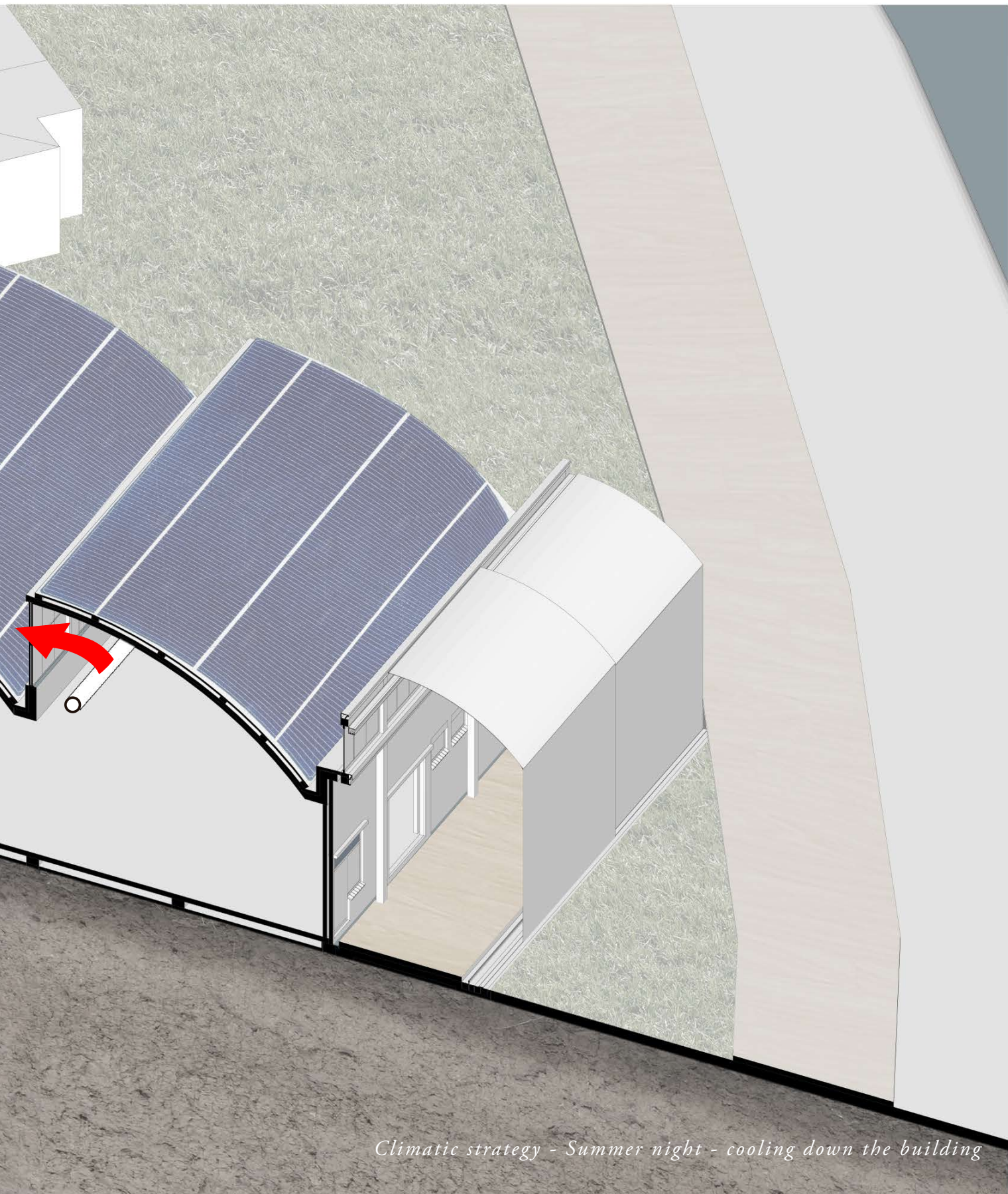

*Climatic strategy - Summer night - cooling down the building*

# BUILDING SEQUENCE

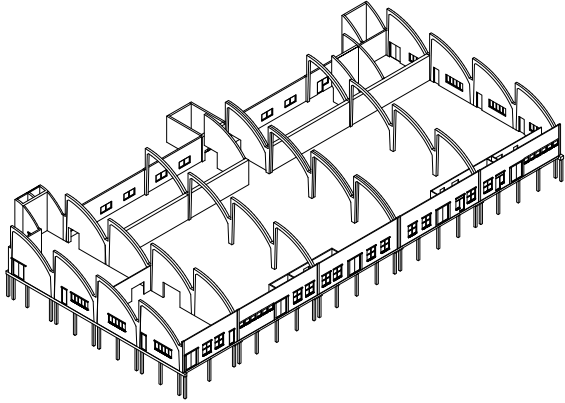

Original state

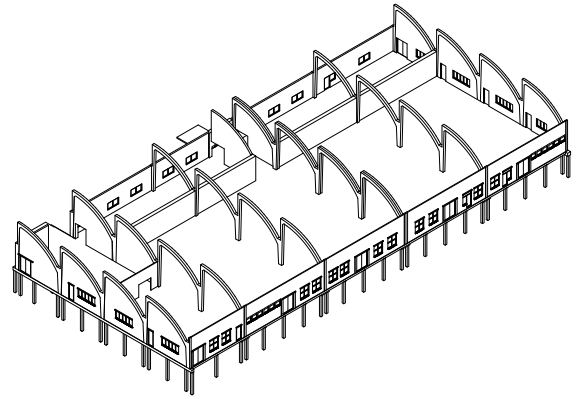

Demolish north facade and two sheds

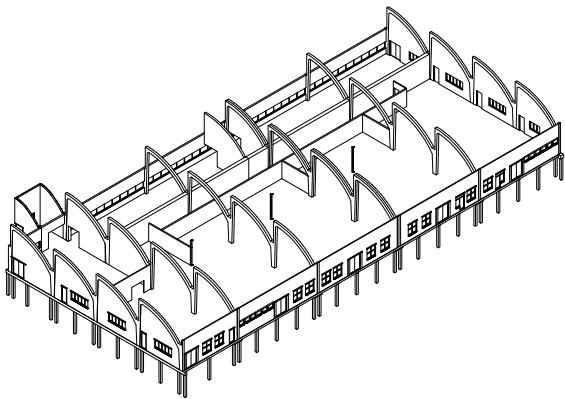

Infill prefabricated panels between columns

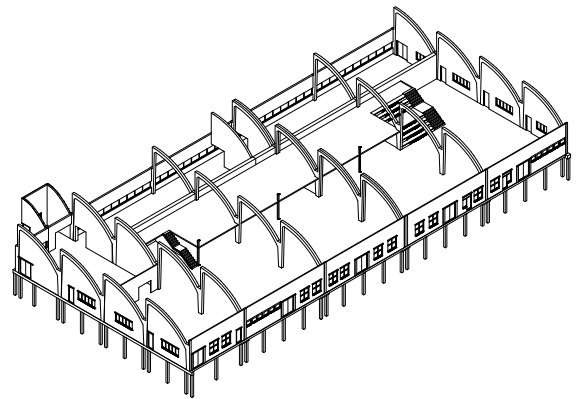

Place mezzanine floor

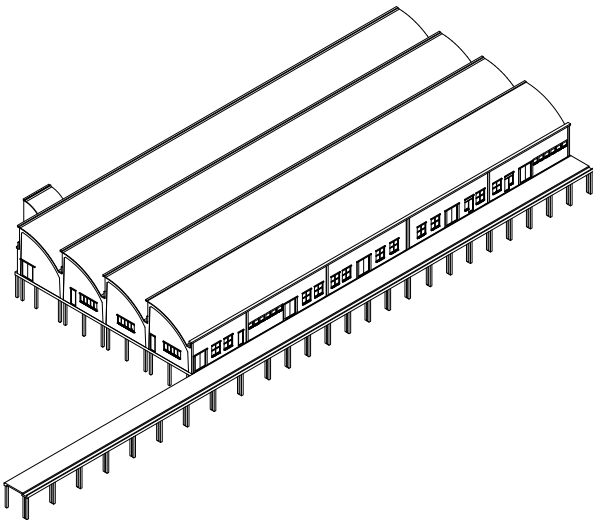

Build new floor and foundation of the new tube

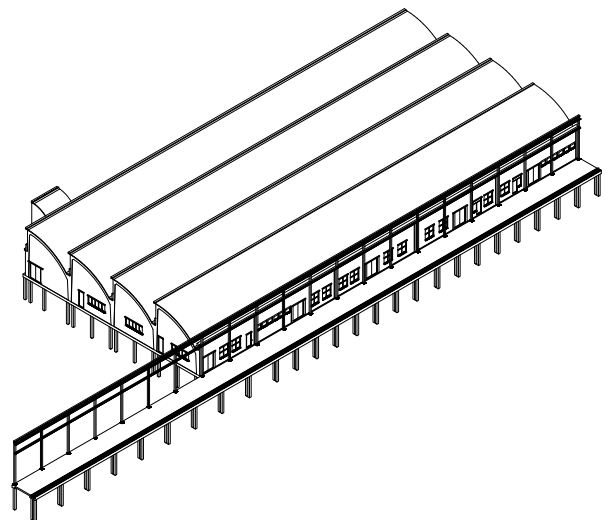

Build steel columns and beams

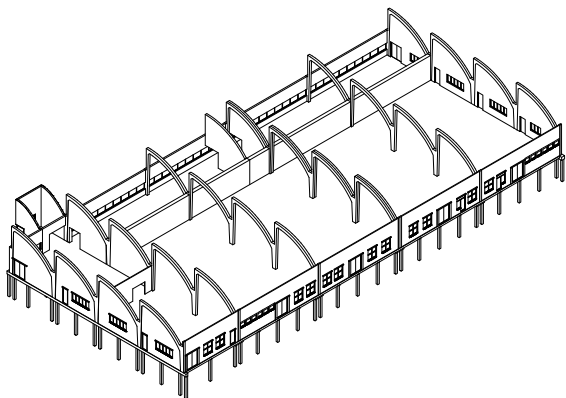

Change north facade and clad the shed as new entrance

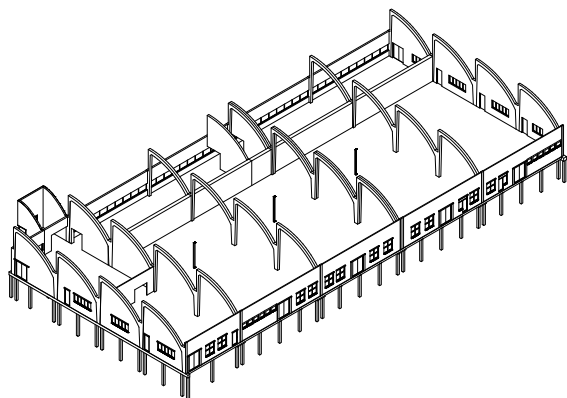

Build new steel columns on top of existing foundation

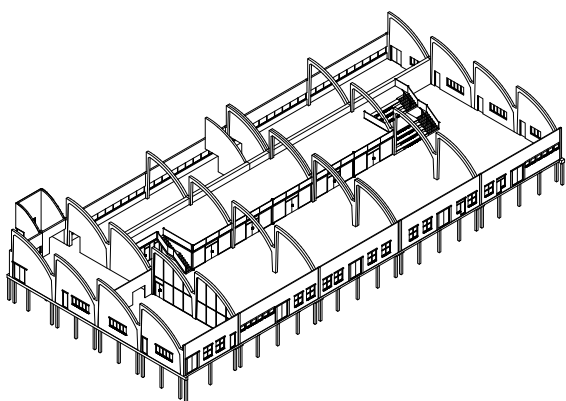

Install glass interior partition walls

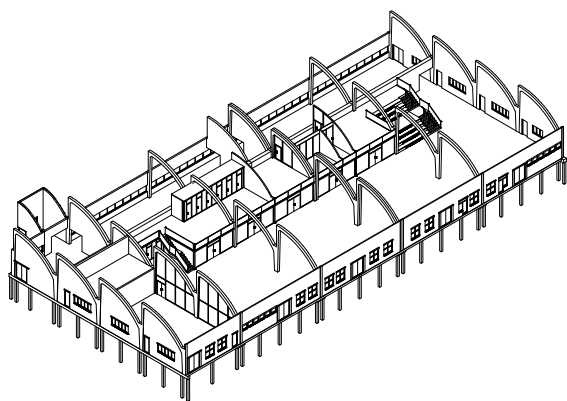

Build partitions on mezzanine floor

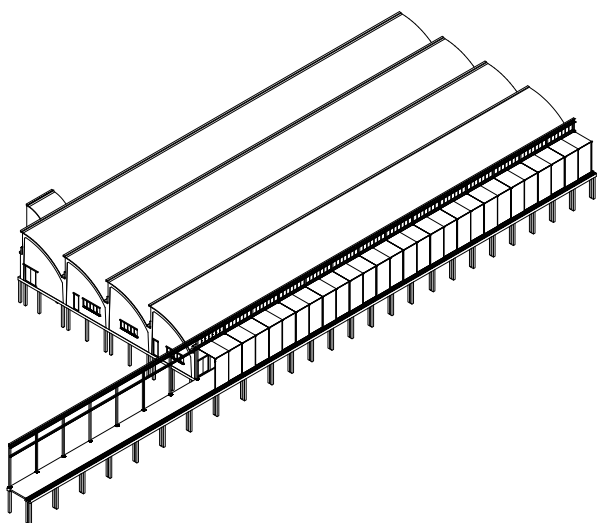

Install sliding glass panels

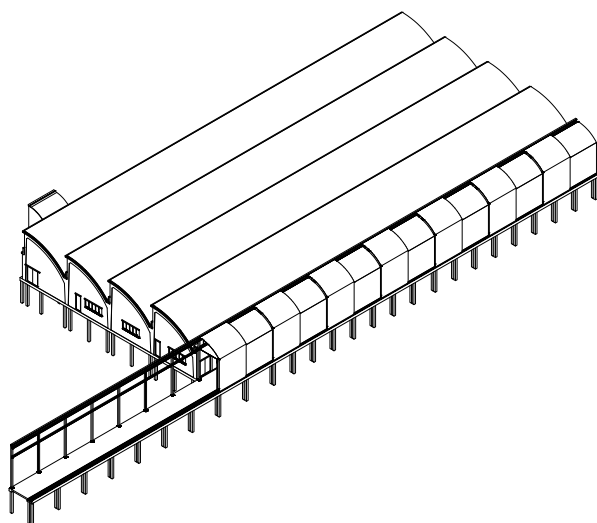

Install sliding sun shading panels



DETAILS

D01

D04

D03

D02

D02A

+7.0

+5.0

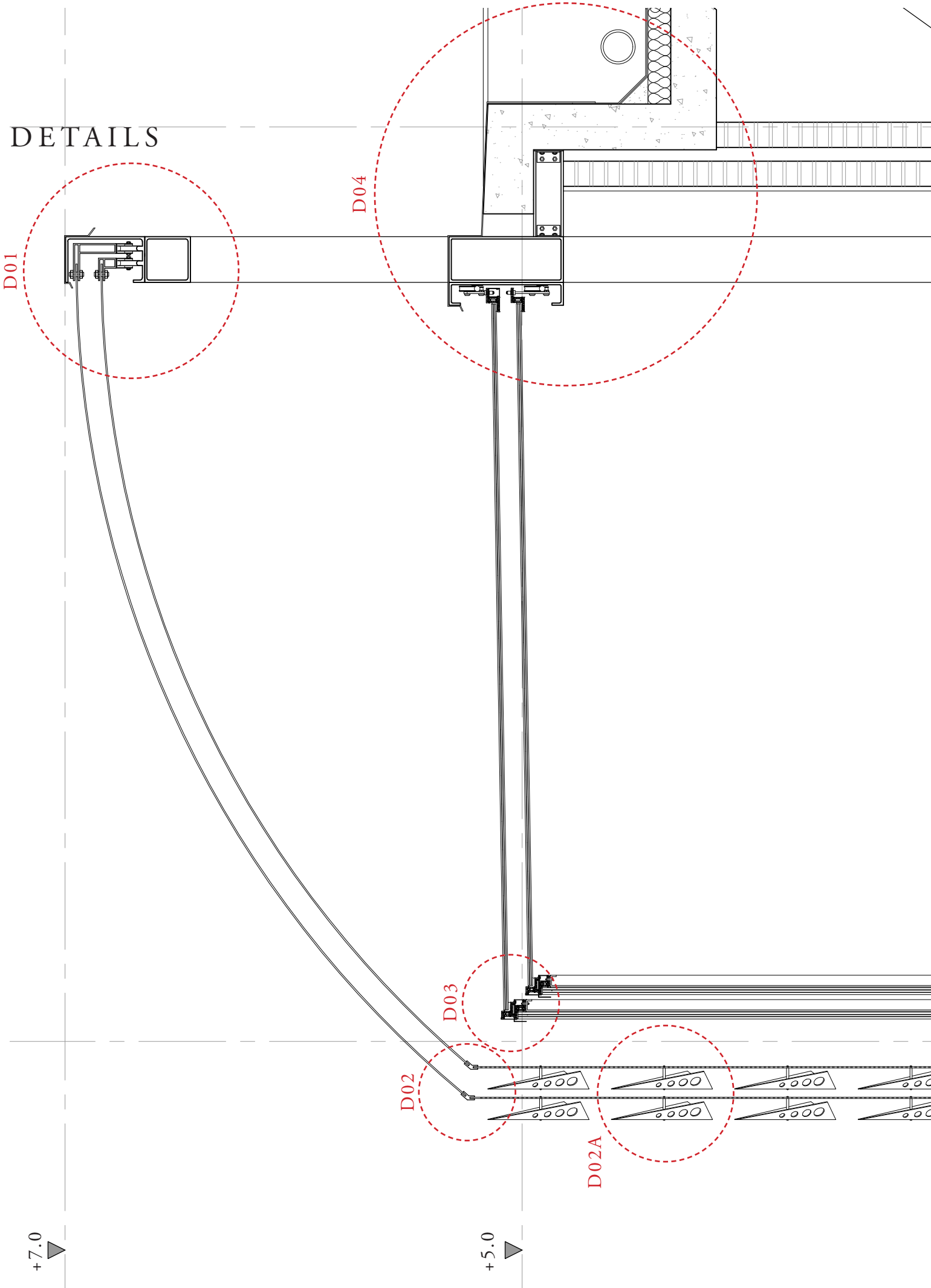

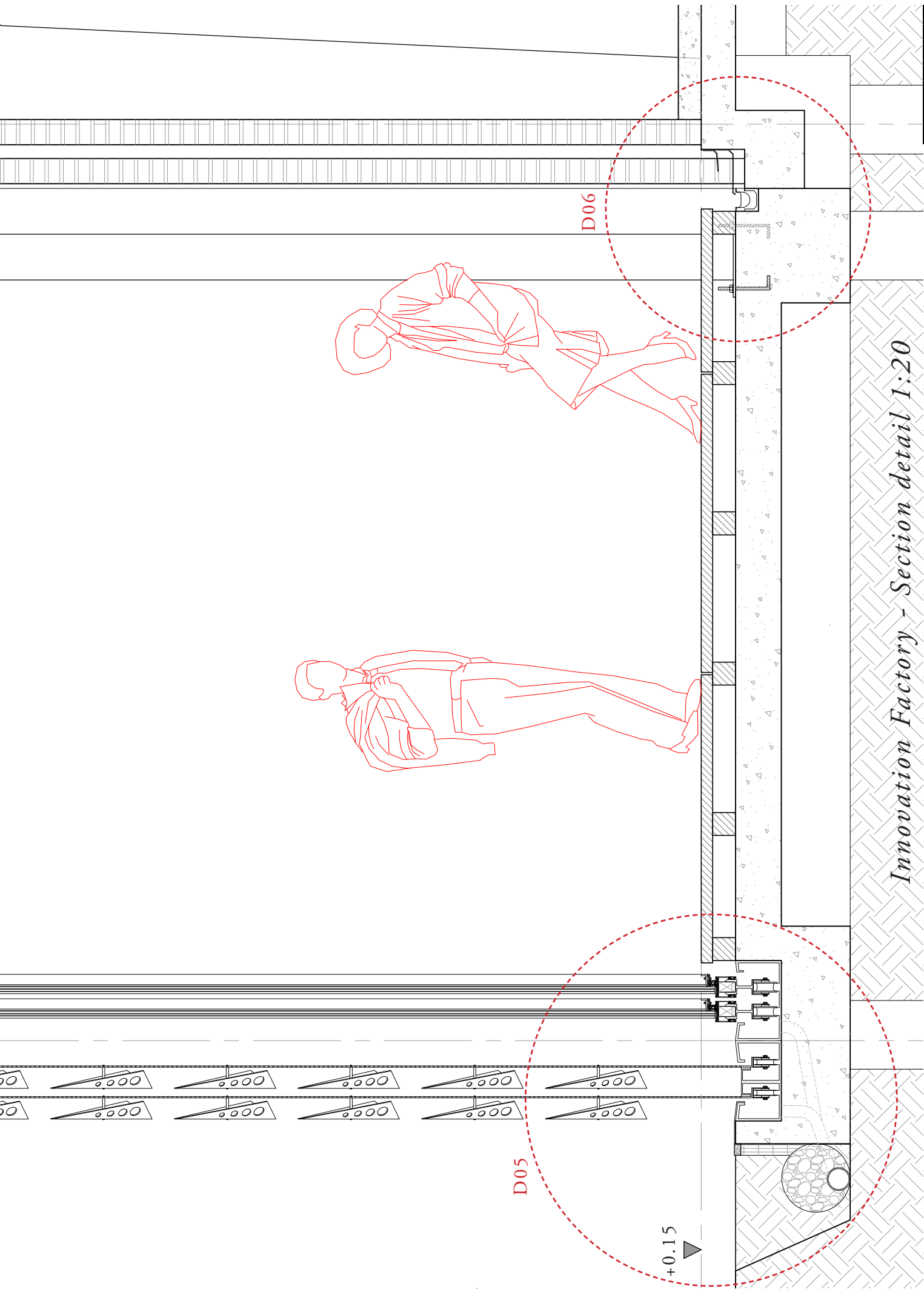

*Innovation Factory - Section detail 1:20*

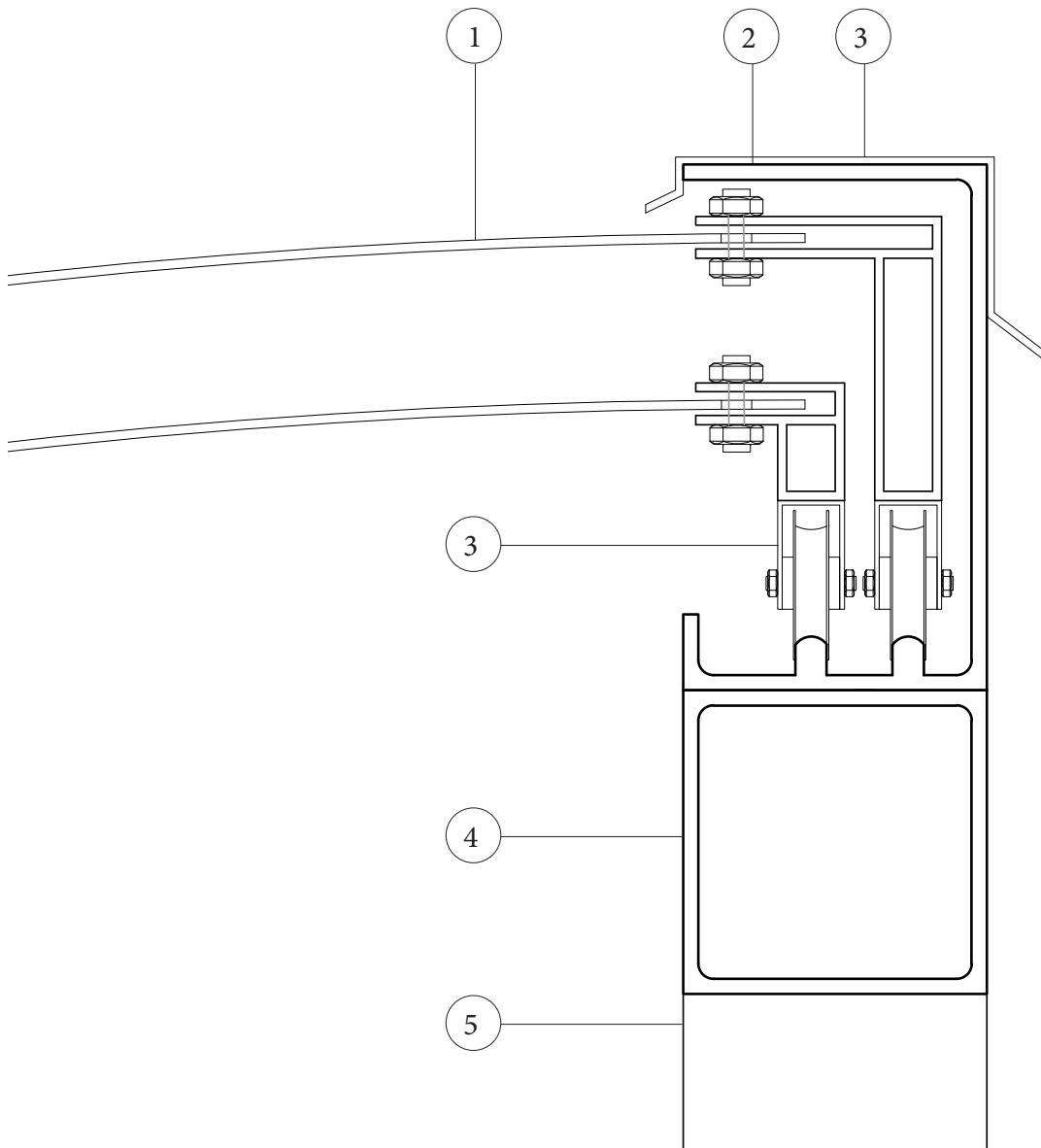

## D01 1:5

1. 5mm perforated steel panel
2. Metal flashing
3. Aluminum bracket on sliding track
4. 200x200mm Rectangular hollow steel beam
5. 200x200mm Rectangular hollow steel column



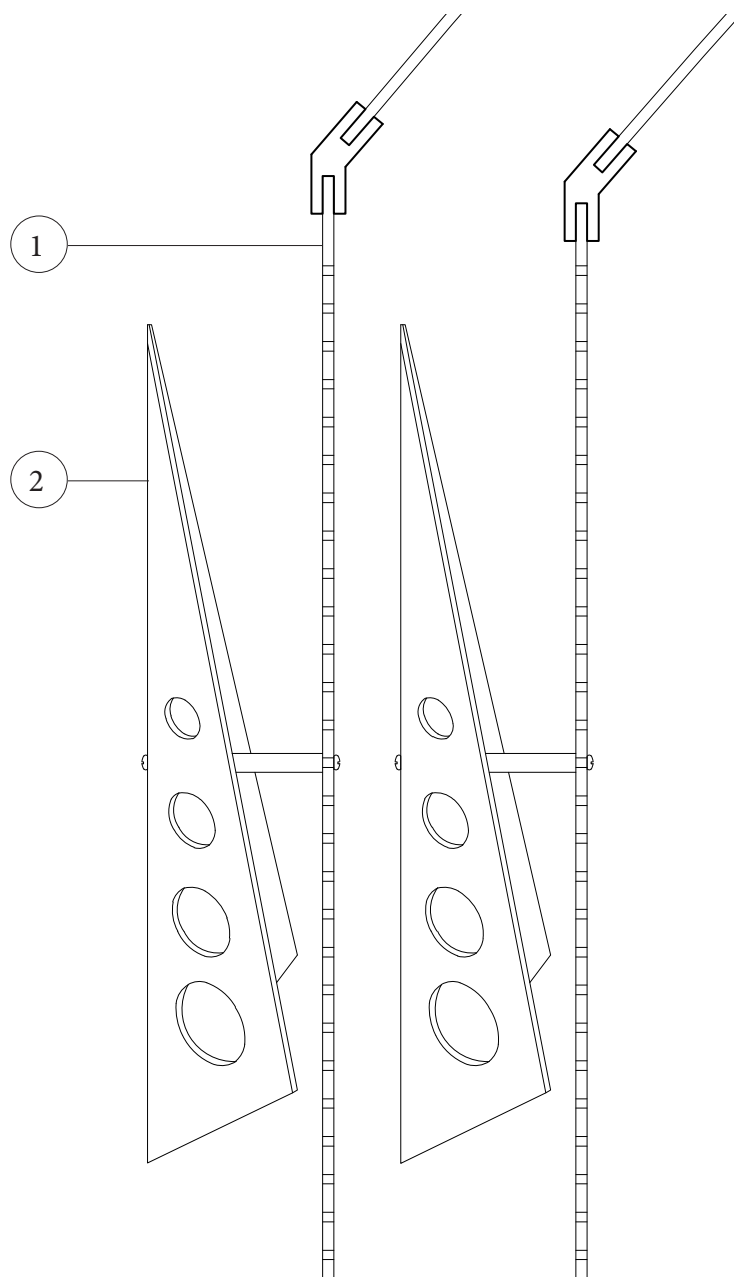

## D02 1:5

1. 5mm perforated steel panel
2. Aluminum wind pivot screwed to the holes of the perforated steel panel

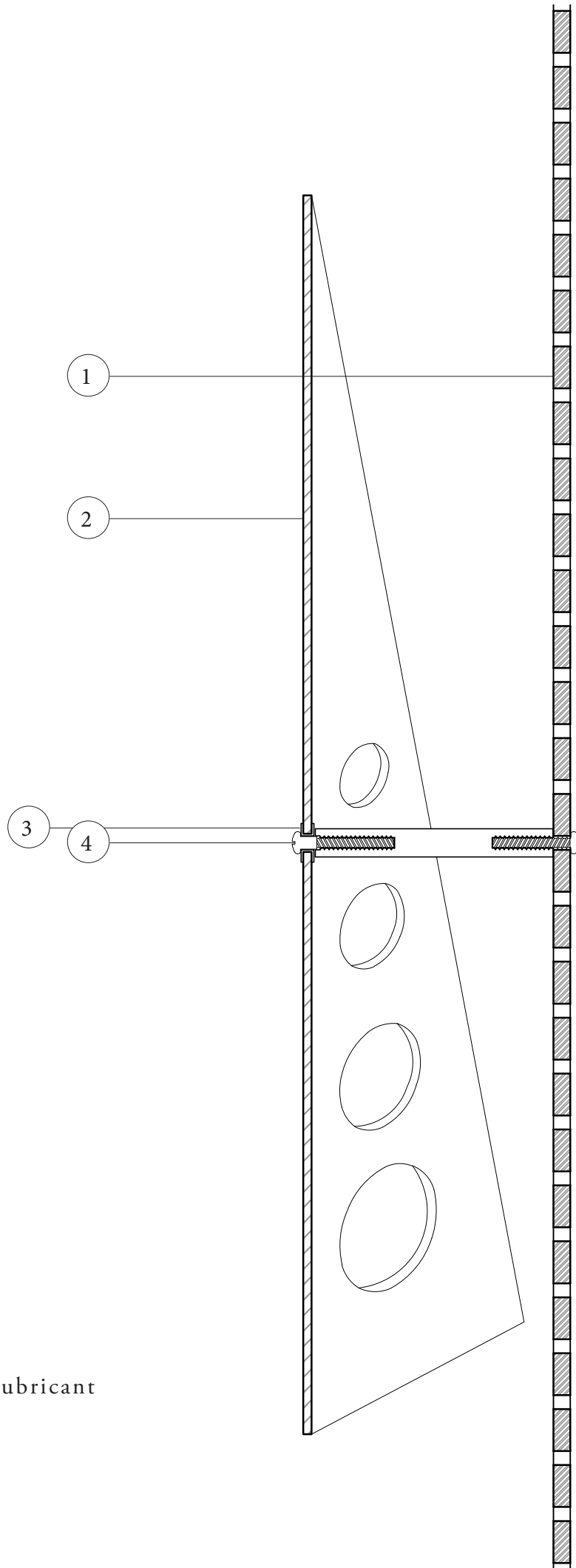

### D02A 1:2

- 1. 5mm perforated steel panel
- 2. 3mm aluminum wind pivot
- 3. Plastic protective ring with lubricant
- 4. M6 Button head cap screw

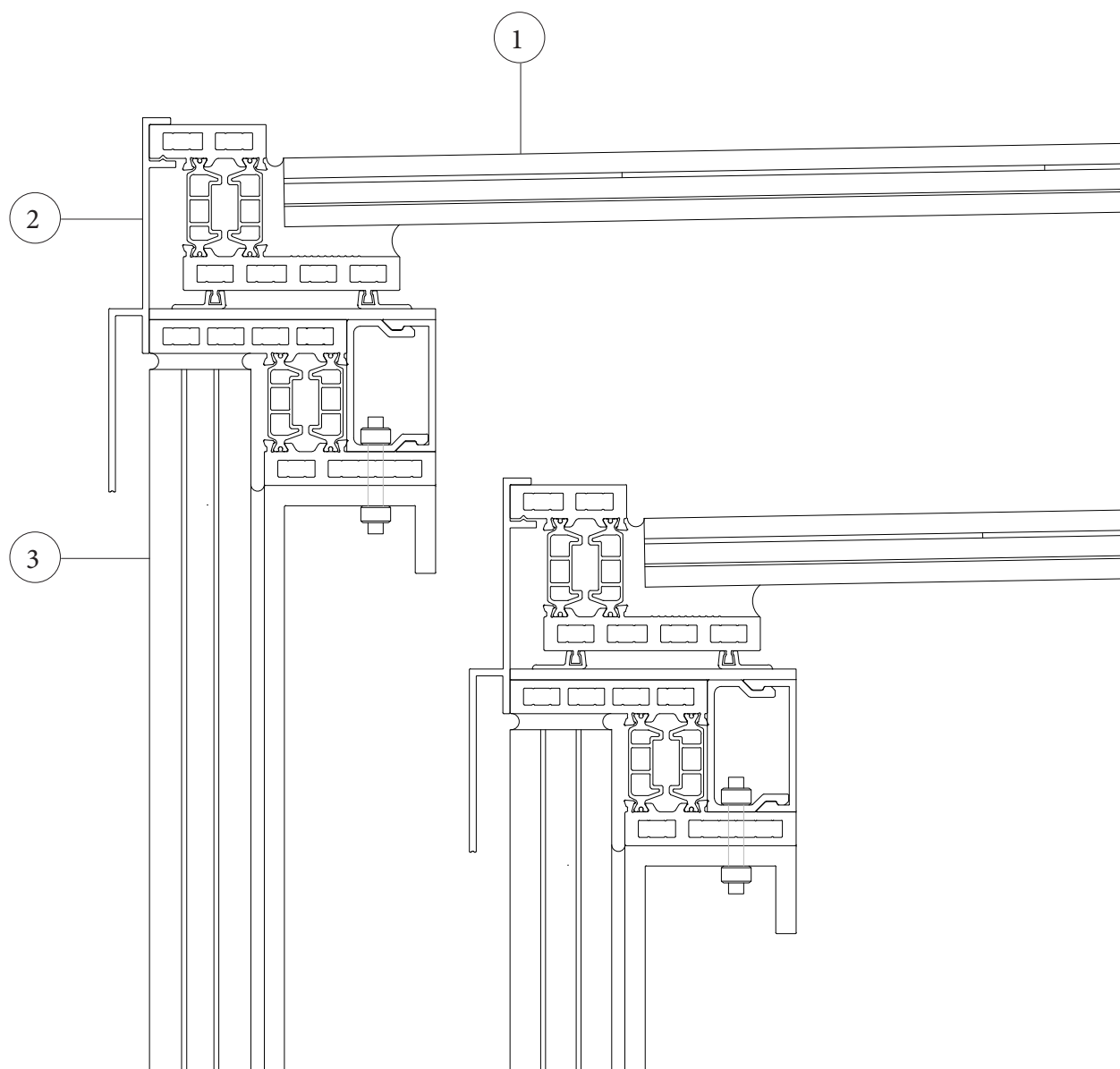

## D03 1:2

1. Laminated glass (from top: 6mm low iron tempered glass, 1.5mm photovoltaic cell, 6mm low iron tempered glass, 0.76mm PVB interlayer)
2. Metal flashing
3. Structural laminated glass



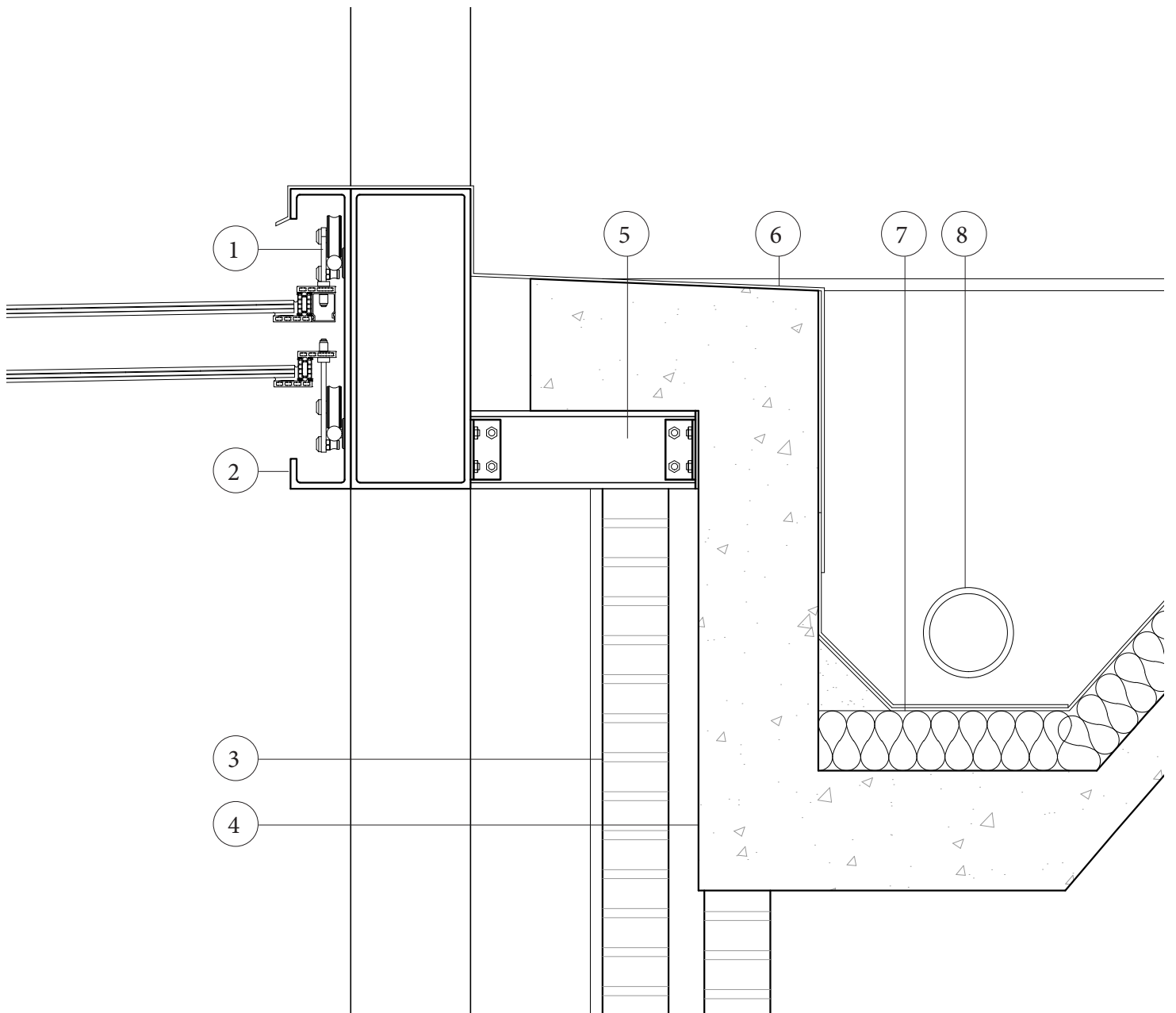

## D04 1:10

1. Aluminum bracket screwed to wheels on sliding track
2. Metal C-channel welded to 200x500mm rectangular hollow steel beam
3. Existing double layered brick wall
4. Existing concrete roof
5. 130mm depth I beam
6. Metal flashing
7. 100mm thk. insulation with waterproofing layer on top
8. 150mm dia. drainage pipe

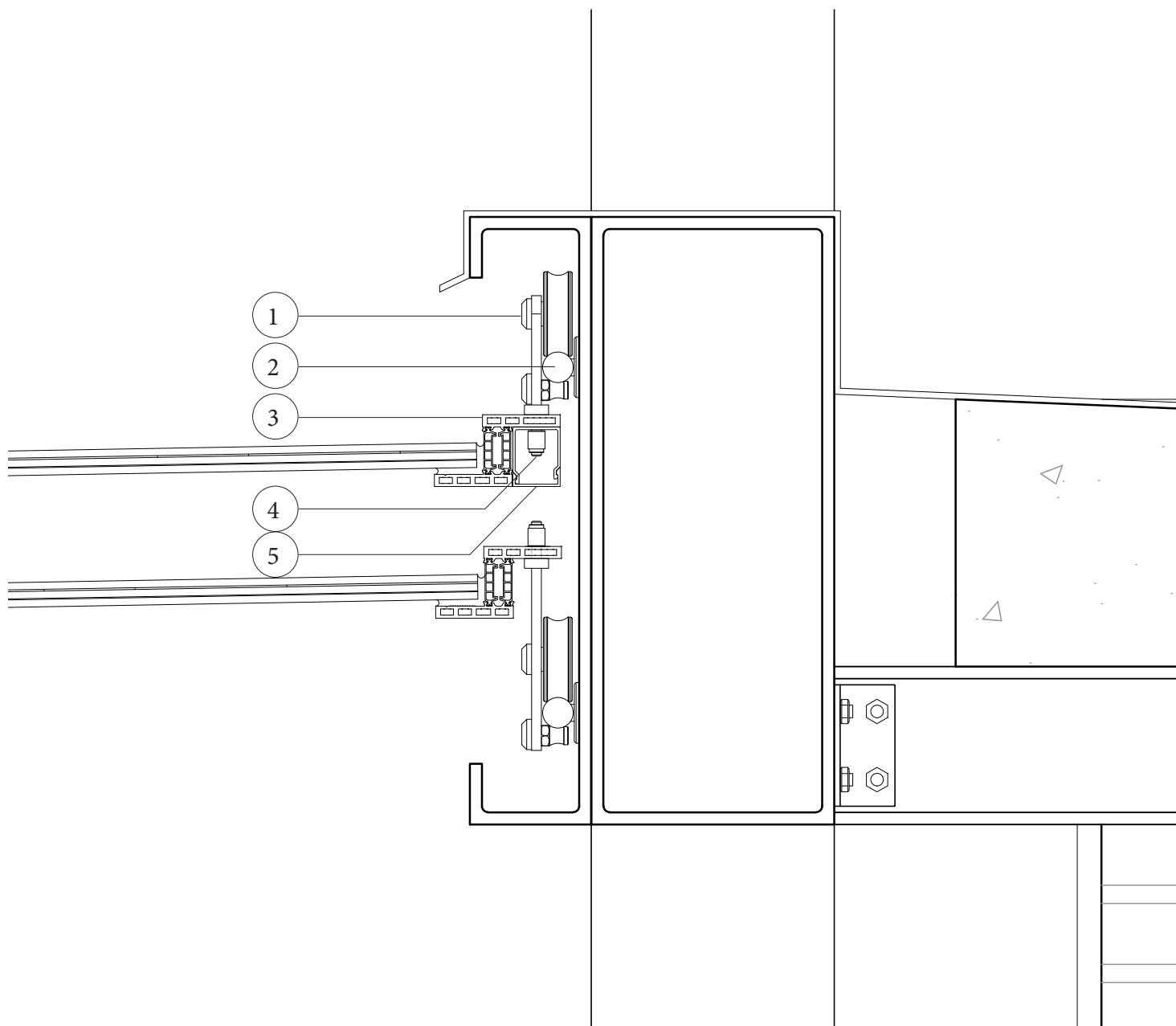

## D04 1:5

1. Duplex wheel
2. Steel rod welded to the C-channel beam
3. Aluminum bracket
4. Steel Socket Cap Screws
5. Aluminum metal cap

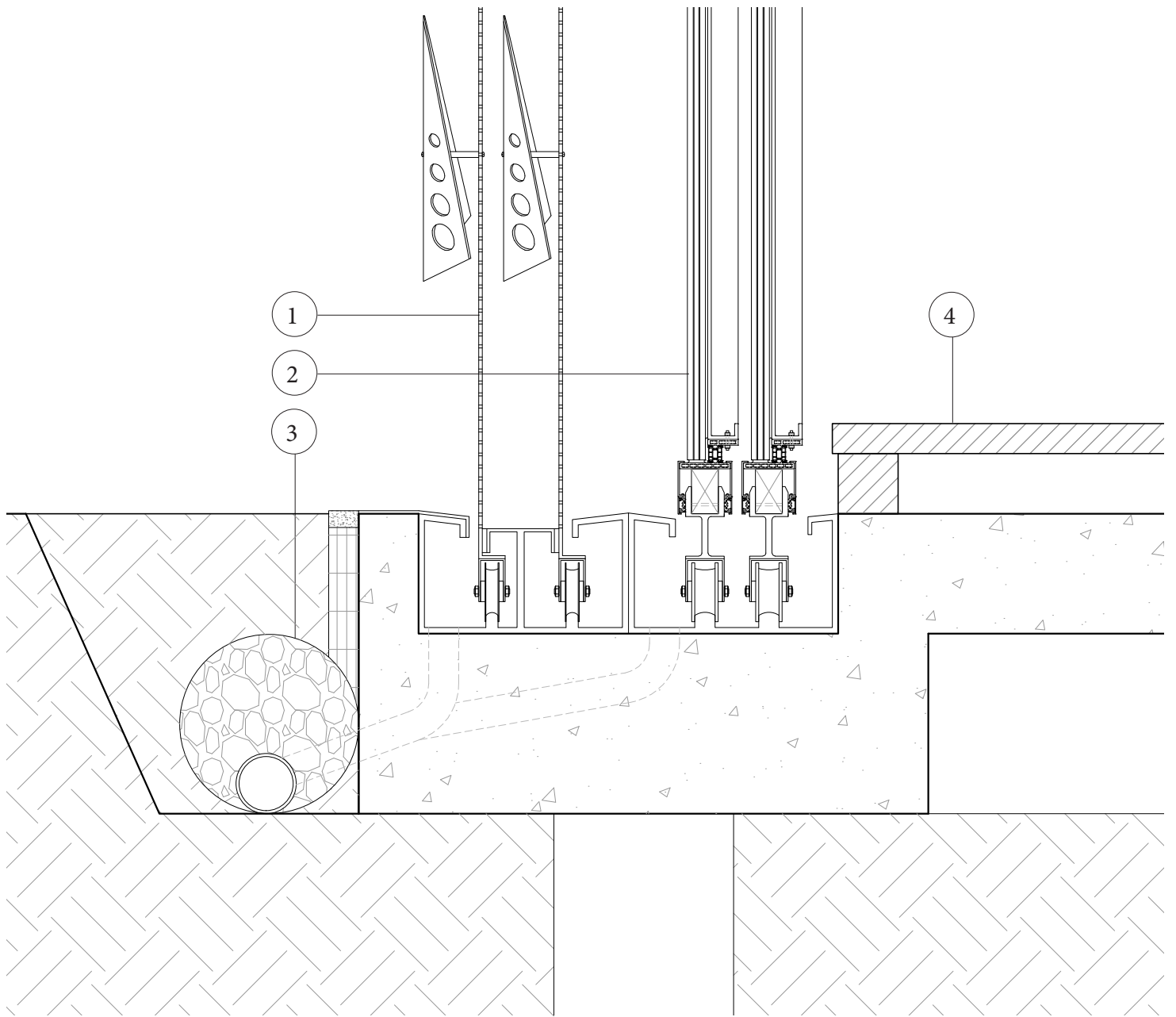

## D05 1:10

1. Sliding sun shading panel
2. Sliding glass panel
3. Sub-grade drainage system
4. Wooden deck on new concrete foundation



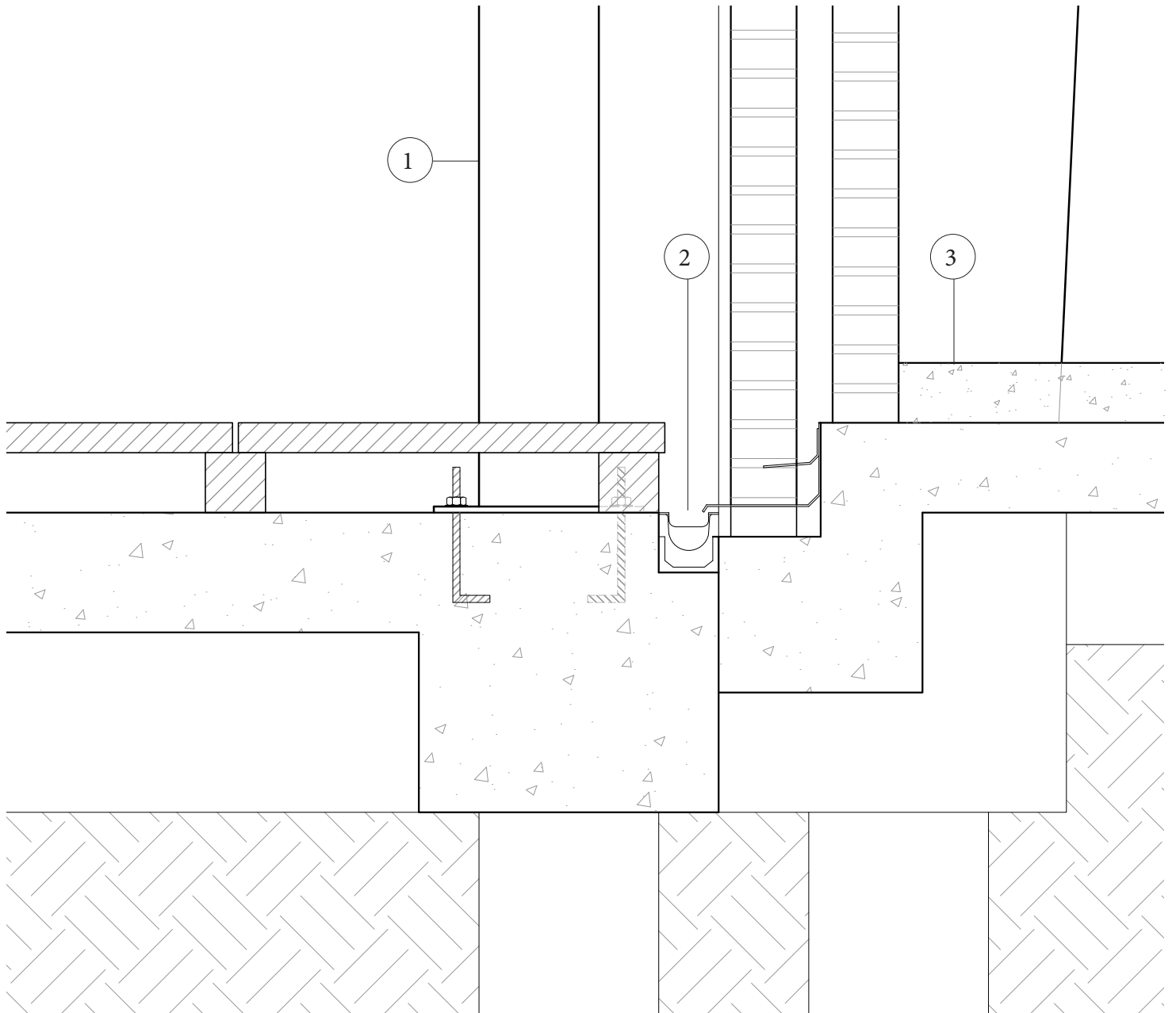

## D06 1:10

1. 200x200mm rectangular hollow steel column
2. Gutter
3. 100mm concrete floor with floor heating and cooling system

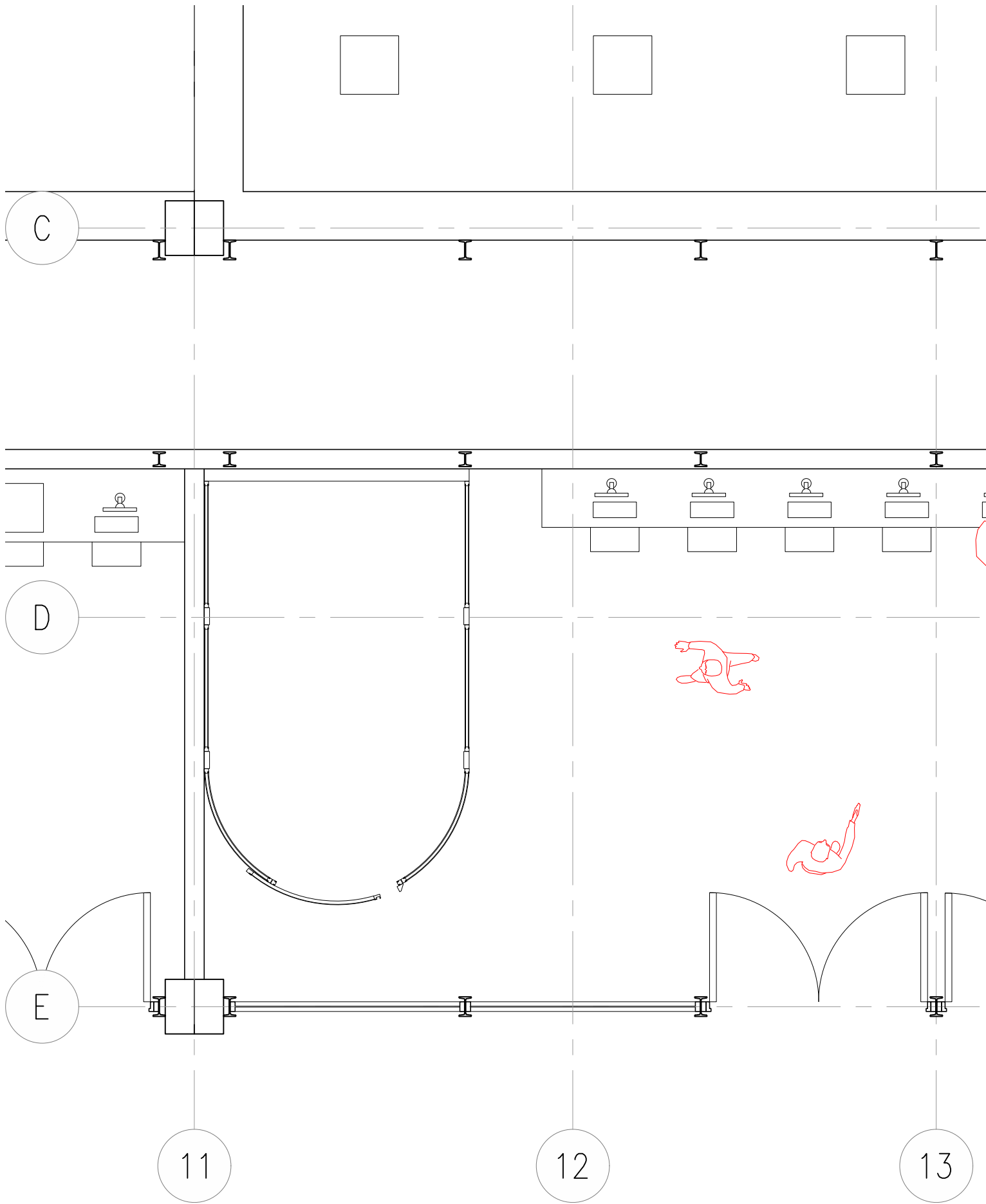

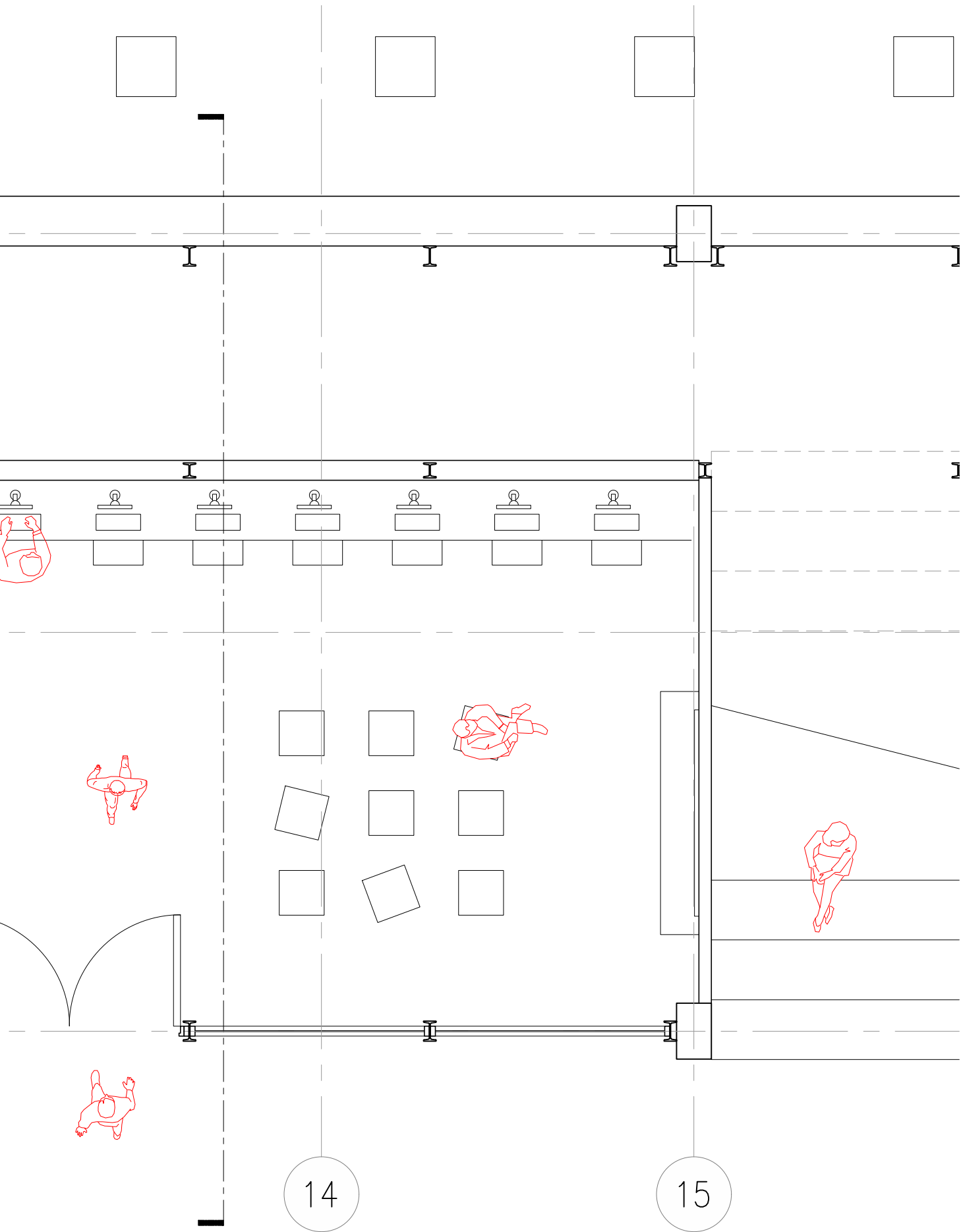

*Partial Ground Plan 1:50*



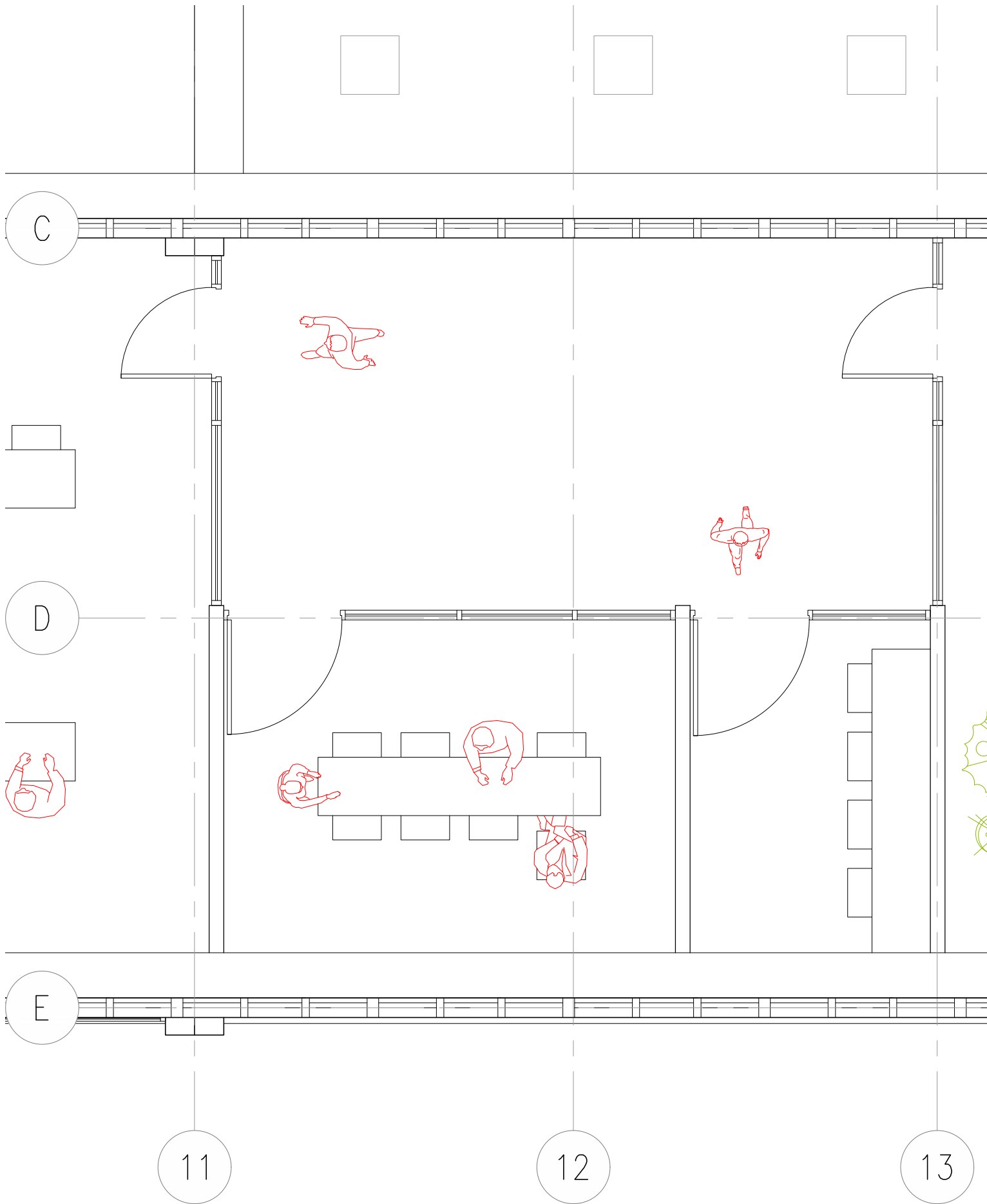

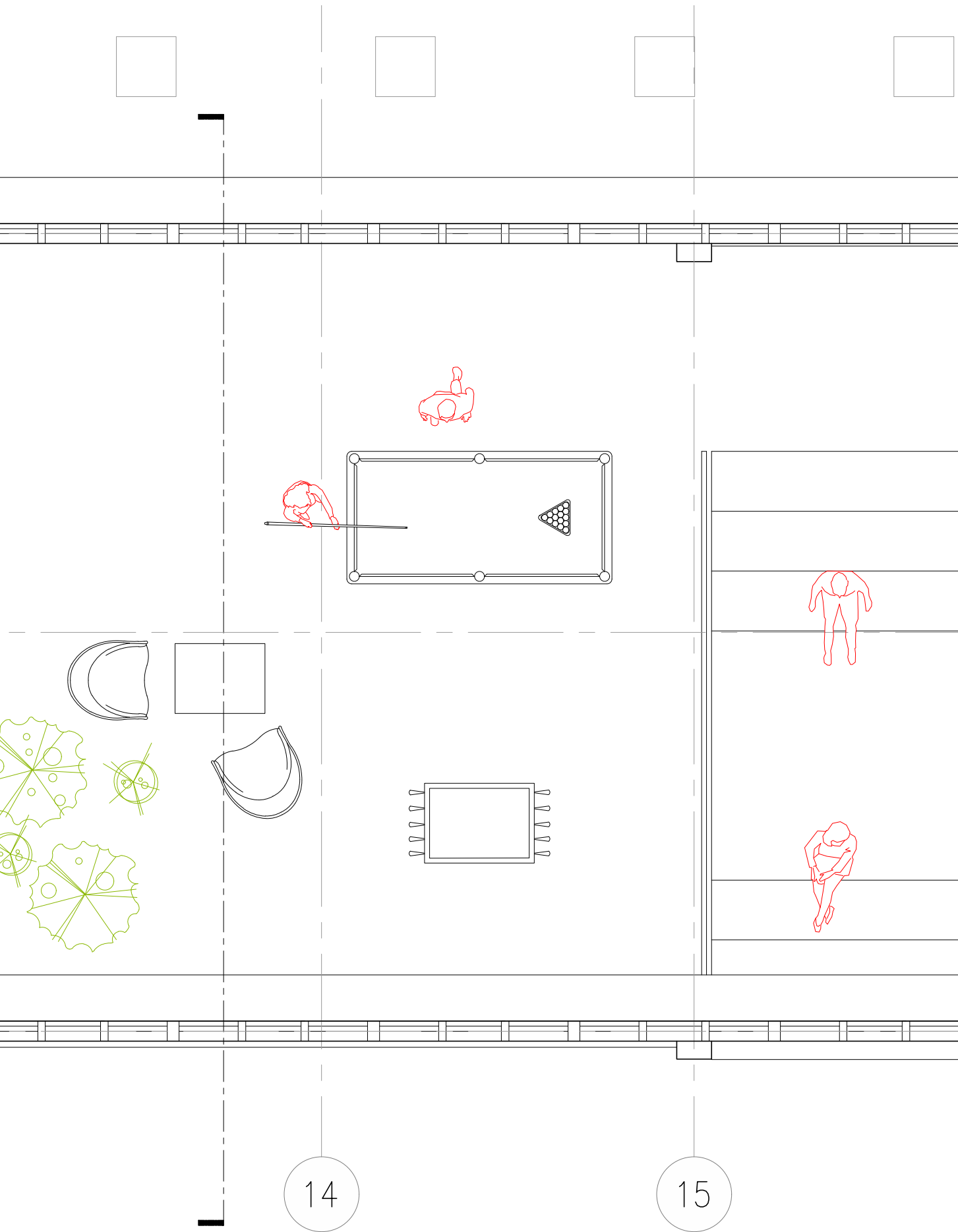

*Partial Mezzanine Plan 1:50*

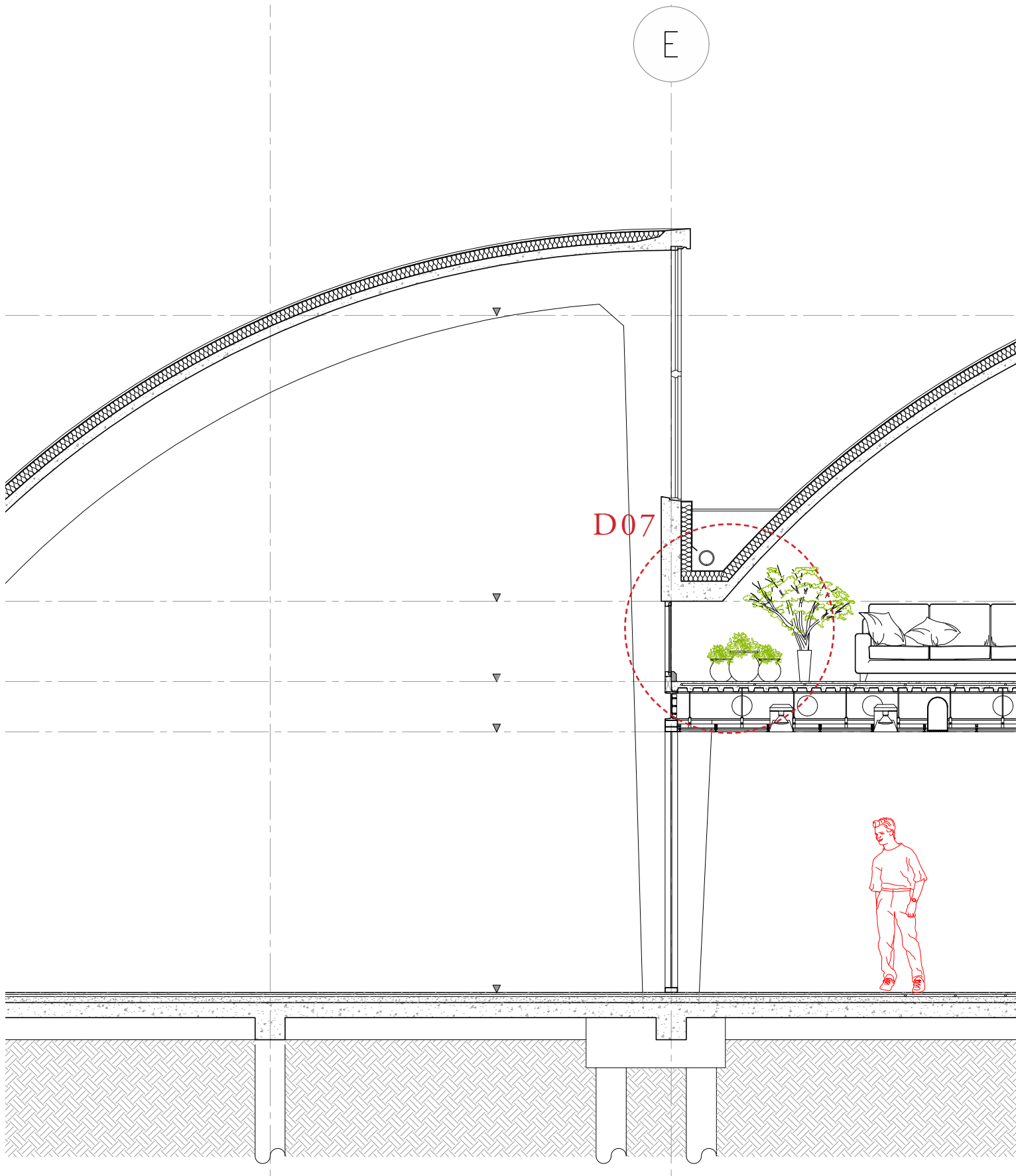



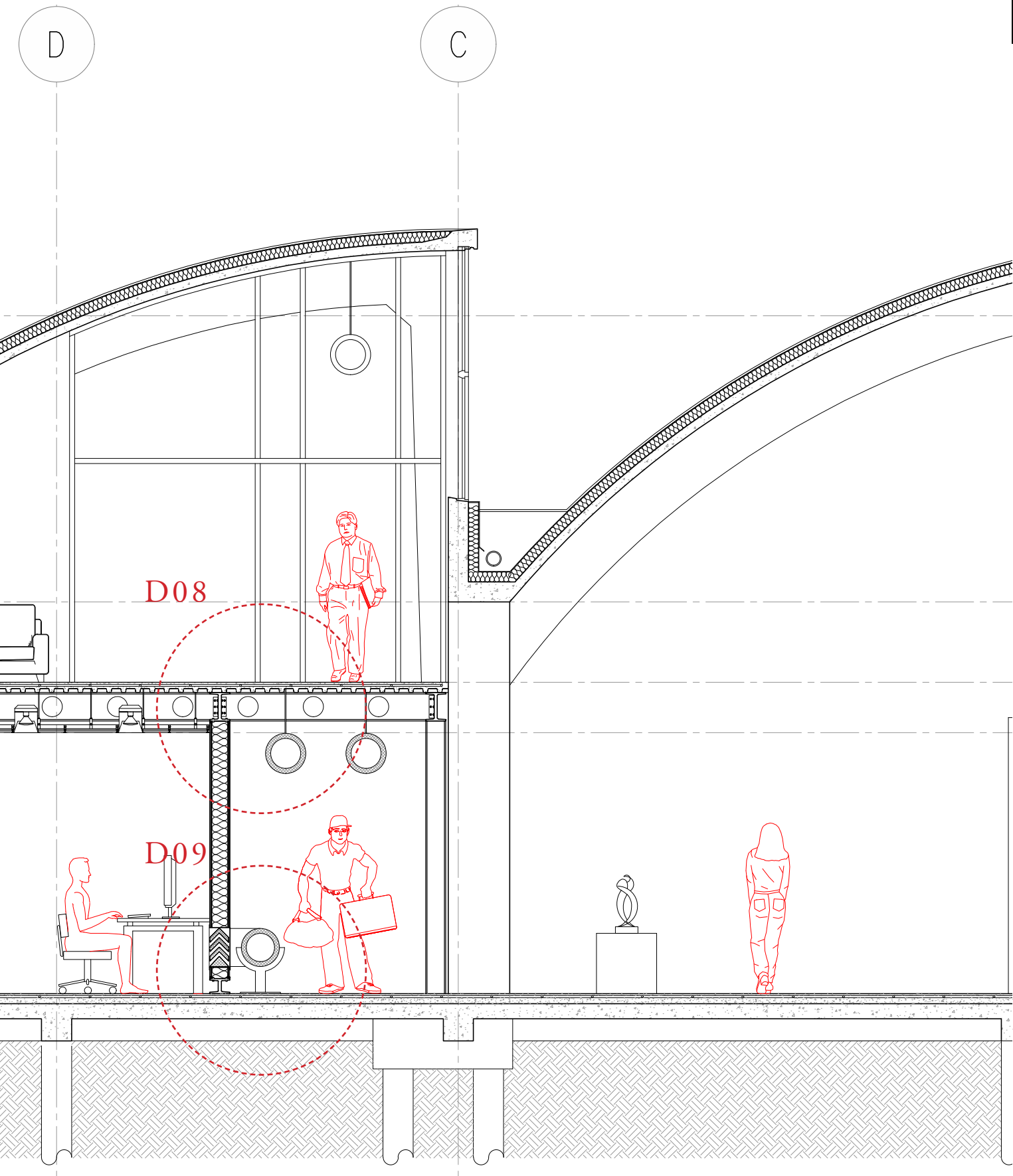

*Section detail 1:50*

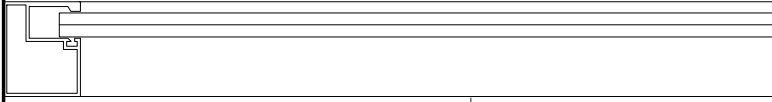
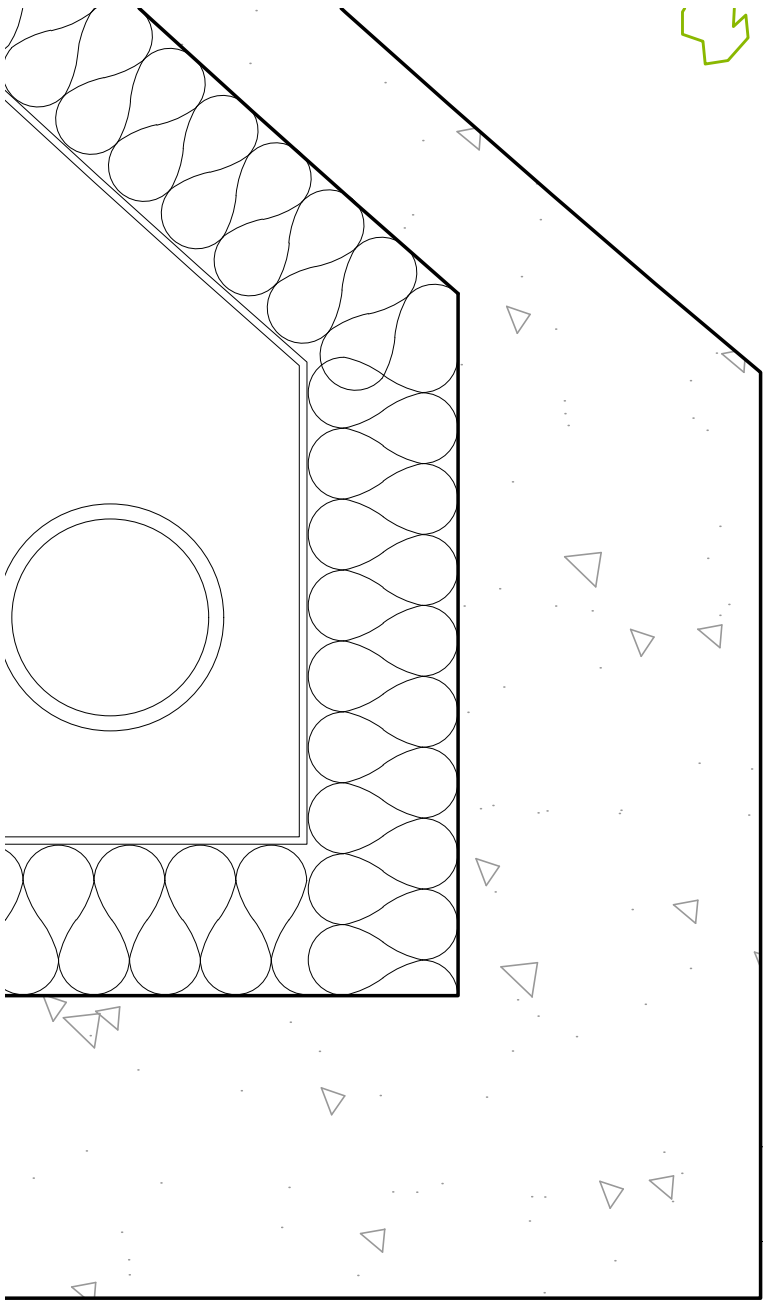

1

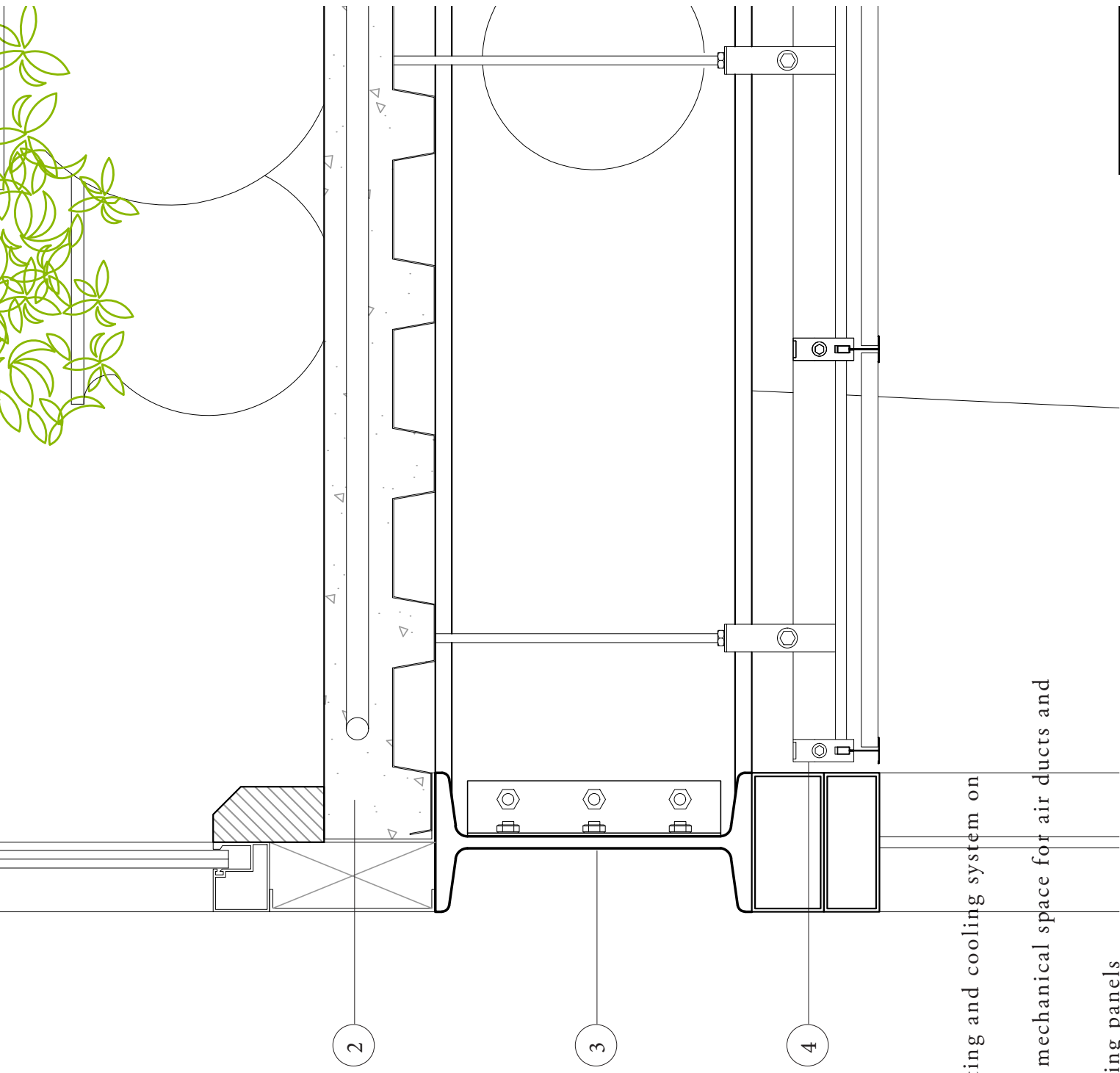

## D07 1:5

1. Aluminum framing window strip
2. 100mm thk. concrete floor with floor heating and cooling system on corrugated metal decking
3. 285mm depth I Beam incorporated with mechanical space for air ducts and lighting fixture
4. Hanging drop ceiling with sound absorbing panels



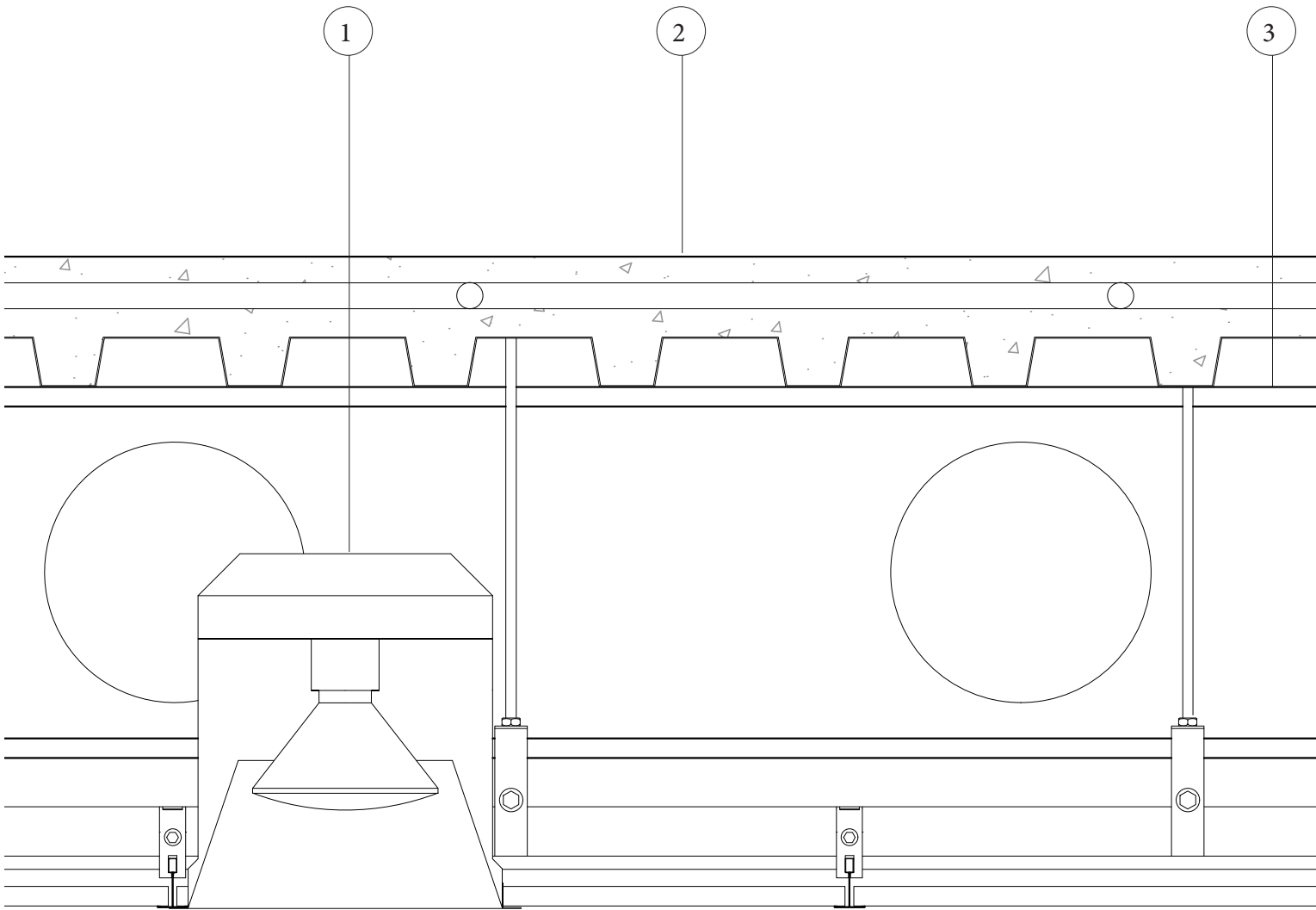

4

5

## D08 1:5

1. Lighting fixture concealed in the drop ceiling
2. 100mm thk. concrete floor with floor heating and cooling system on corrugated metal decking
3. 285mm depth I Beam incorporated with mechanical space for air ducts and lighting fixture
4. Metal stud wall (10mm interior wall putty, 15mm gypsum panel, steel stud, 150mm insulation)
5. 200mm dia. air exhaust duct wrapped with sound absorbing insulation

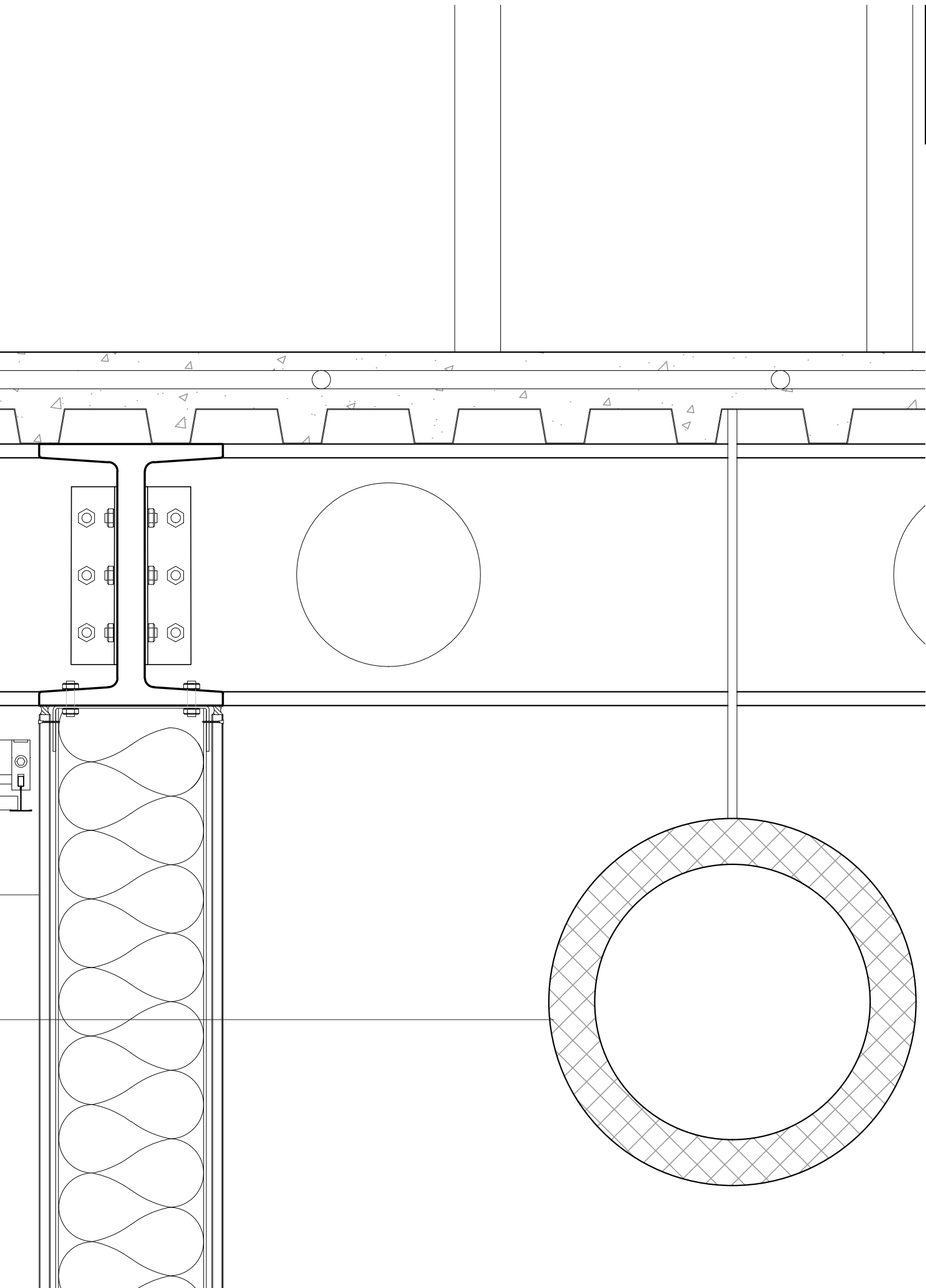

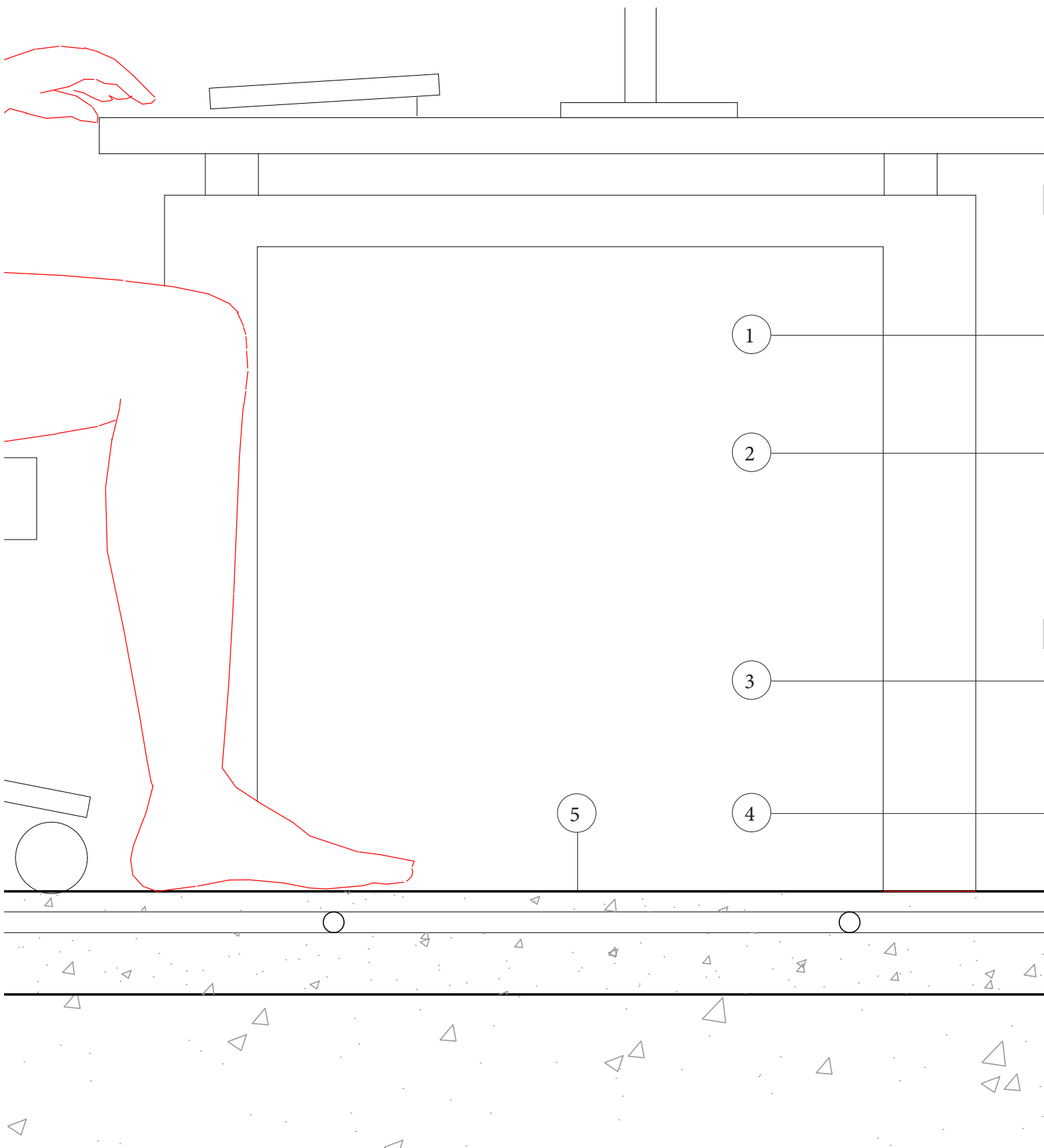

## D09 1:5

1. Air inlet grille with sound insulation
2. 200mm dia. air supply duct wrapped with sound absorbing insulation
3. Metal support rack for the pipe
4. 150x200mm steel I beam
5. 100mm thk. concrete floor with floor heating and cooling system casted on existing concrete floor



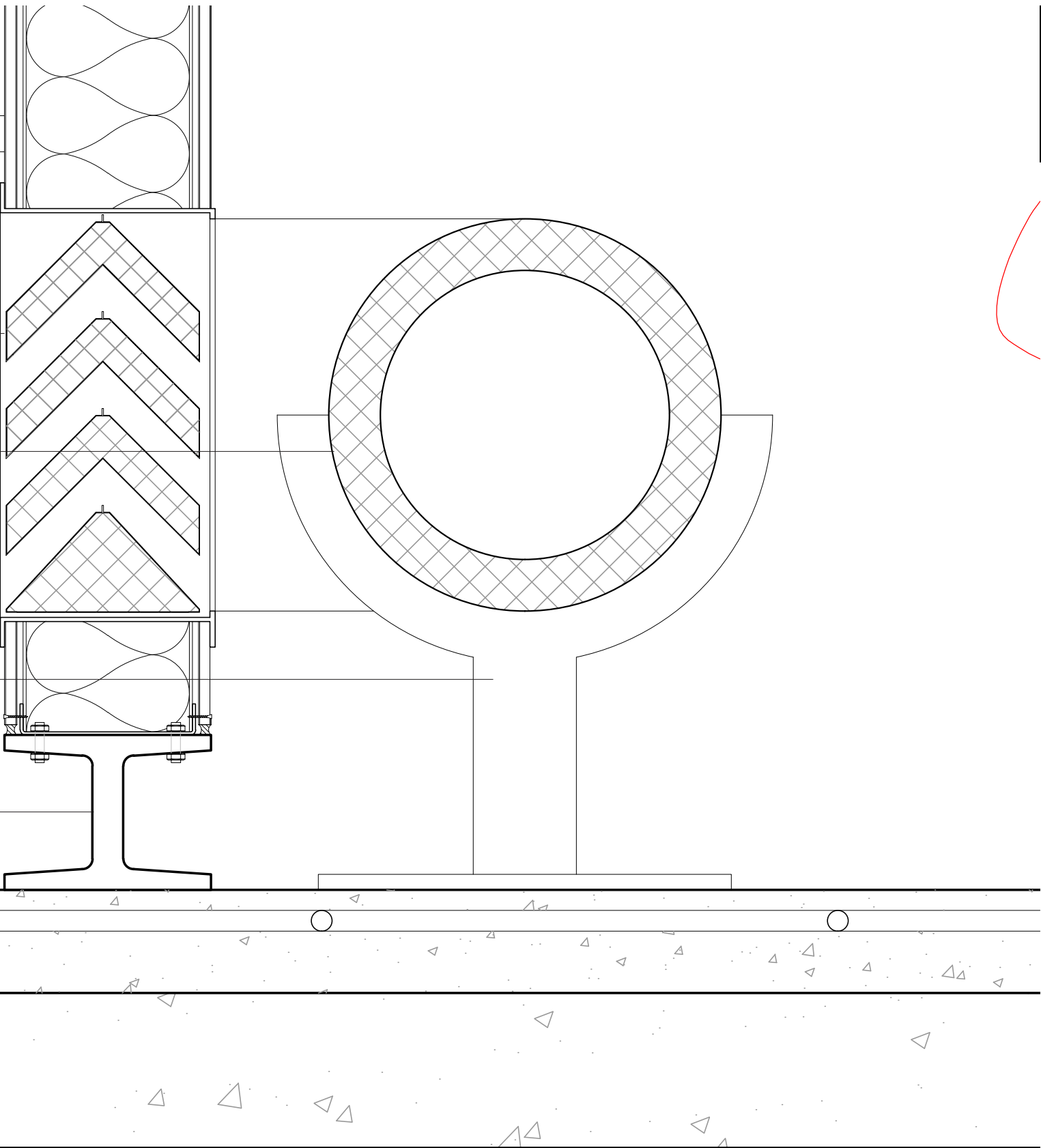





R

*Reflection*



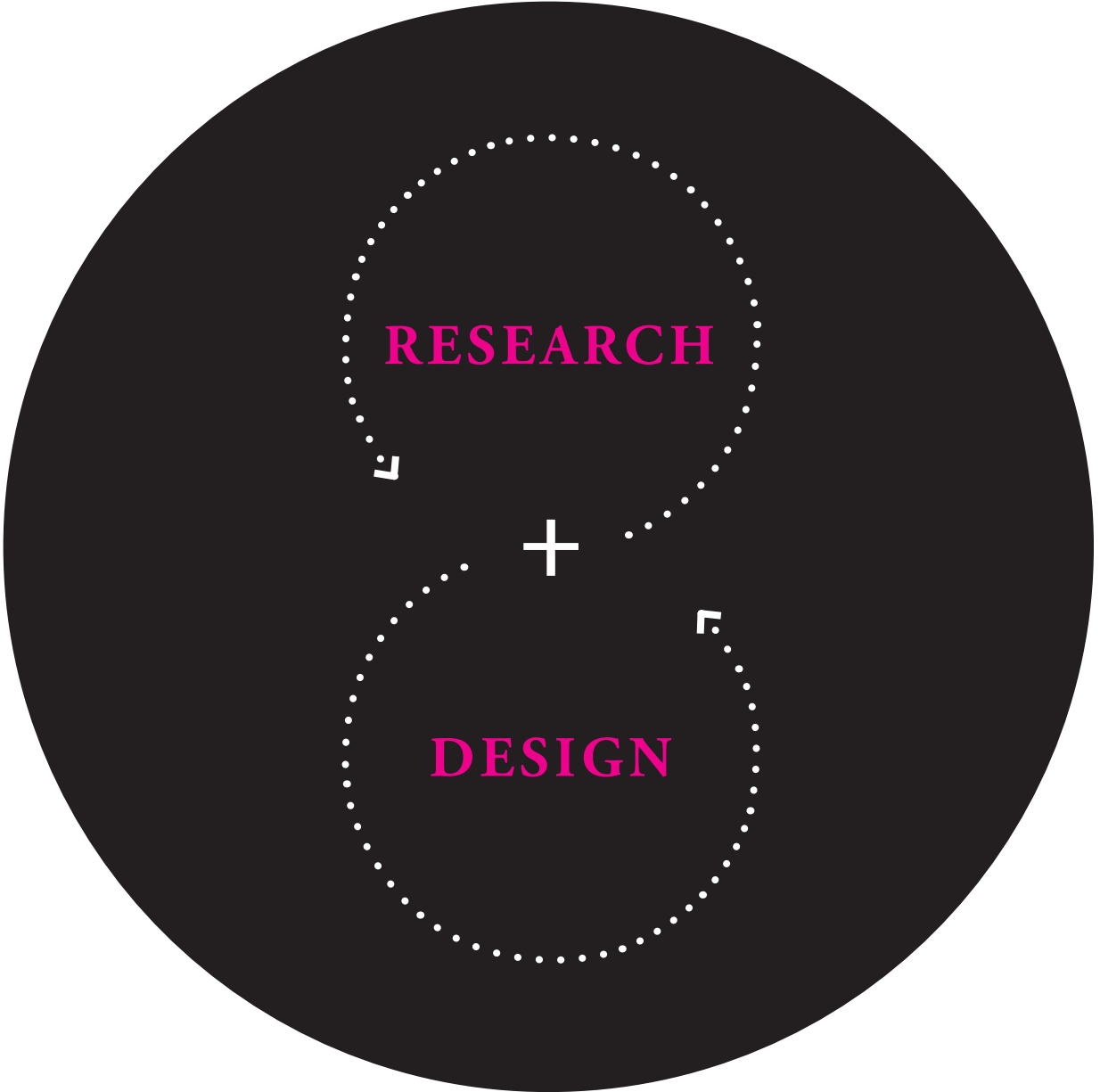

# REFLECTION

## **The relationship research and design**

In the heritage studio, research and design goes hand in hand, as it has to do with the preservation and renewal of existing architecture. This is important in the design decision making process when finding the right architecture intervention that is an appropriate balance between the old and the new. Throughout the course of this thesis project, I became familiar with several research methodologies that have informed the design process of the project which I will elaborate below.

Heritage studio is very context based, hence extensive research, especially historical research is required to understand the specific background of the given project. A critical precursor to heritage design is diving in the archives, such as the historical photographs and architectural drawings. This allows the researcher to understand the past socio-cultural discourse in relation to the construction and the design intention. A sensitive design strategy requires an in depth understanding on the cultural significance of the existing, so that the intervention is able to retain the positive qualities of the building and more importantly, the cultural values they embodied.

As heritage projects deals with the existing, qualitative research is also critical. Careful photo-documentation, measurements, sketches and notations must be taken during on-site visits so that the intervention deals with the real situation. This is particularly important in the design of the details regarding any new intervention, in order to understand what and how should something be removed, added or connected if necessary.

**The relationship between your graduation (project) topic, the studio topic (if applicable), your master track (A, U, BT, LA, MBE), and your master program (MSc AUBS)**

As mentioned in the previous question, heritage studio deals with critically questioning how to respond with an intervention to an existing building. As mentioned by the chair of Heritage and Architecture Wessel de Jonge, “when dealing with an existing context or building, it should be the source of inspiration for creativity”, I therefore questioned myself how to extract the essence of the existing heritage in the Head of the Cape (the prescribed site location for my project, located in Hembrug, an industrial estate near Amsterdam) as the design starting point for the intervention. This led me to a methodological line of inquiry informing the design process through an in depth study of Hembrug’s historical context and a typological study of the existing buildings.

My project relates to the wider architectural track through the principles of sustainability. Wessel De Jonge, the chair of Heritage and Architecture studio, describes the built environment as already saturated – “a full water basin”. All materials and space are finite, if we follow the same discourse of endless construction, then the basin will spill over which may exasperate climate change and the already large carbon footprint. The heritage studio deals with this problem, through upcycling existing buildings through reprogramming, reuse and design.

During the exploration on how best to intervene with my buildings in the Head of the Cape, I was inspired by Lina Bo Bardi’s project on SECS Pompeia, as well as the studio field trips to LocHal and De Pont in Tilburg. I further extended my study to examine the potential of the intervention in accommodating for future trends. This led me into the study on the social impact that my site has on its surroundings. At a center of two growing cities, Zaandam and Amsterdam, and the junction of Noordzeekanaal and the Zijkanaal G, my site is highly visible from its neighborhood and easily accessible by water. It is also right next to the future Haven-stad, an area planned by the Amsterdam municipality to become a highly dense mixed used



area. In order to support the potential influx of 150,000 future residents, new cultural, recreational and functional amenities are required. These findings have directed my project in creating a cultural hub which includes an art studio, a museum, a theatre and a maker library – a new typology of libraries that encourages the simultaneous production and consumption of knowledge, through the new emerging prosumer culture.

Moreover, part of my project ambition is to discover new ways in combining advancements of technology with heritage design, as a symbol and representation of the up-cycle movement and the innovative culture, I was able to elaborate on a new approach to architecture -- a study on innovative solutions in readapting old industrial buildings. I expressed these ideals in my design through the key intervention for the former ammunition factory, a new mass inspired by the existing structure that will serve as an indoor climate control element of the entire building.

*Reference:*  
*De Jonge, Wessel. "Sleeping Beauty."*  
*Delft Lectures On Architectural Design,*  
*2017/2018, 327.*

**Elaboration on research method and approach chosen by the student in relation to the graduation studio methodical line of inquiry, reflecting thereby upon the scientific relevance of the work**

The Heritage studio methodical line of inquiry revolves around 3 aspects, the cultural value, the architecture and the building technology. The scientific relevance of my thesis project is reflected in the design, as the entire research process was closely related to the three themes.

I started off my thesis with the research question “What is the character of my site, i.e. the Head of the Cape?” Along this line of inquiry, I evaluated the existing buildings around my site by their typology, structure, spatial quality and also materiality. I realized from the results that they are the crucial components to cultivate the industrial atmosphere, the greatest cultural value of my site.

To translate the findings into an architectural design that inherits the industrial character, I took the building typology as a design starting point. The former ammunition factory is made of four consecutive and identical 70-meters long curved shell tubes, a profile of repeated components which is typical for the factories built in 1950s. A new tube with the same curved profile is added and attached to the factory on its southern side. The idea for the transformation is to create a gradual change in spatial experience throughout the building, from solid to transparent, from closed to open, from dark to bright, from indoor to outdoor, from rough surfaces to fine finishes. In order to distinguish the new intervention and the existing building, the new tube is made of transparent material, creating a contrast to the existing brick facades. A new time layer is added with respect to the old ones.

The third aspect of the studio is building technology. The new intervention is more than a repetition of the existing shape; it is also a statement of being innovative. As the ambition of my project is to inspire innovation, I was convinced to integrate innovative solutions that can make the building more climatically sustainable, yet at the same time still retain its qualities.

It aligns with the central theme of the heritage studio, the exploration on how to give an old building a new life. The new tube can be opened and closed to regulate temperature in different seasons. In summer time, the glass box is open to allow breeze into the building and thus enhance natural ventilation. In winter time, the glass tube will be closed completely and create a sun space to mitigate the cold weather.



**Elaboration on the relationship between the graduation project and the wider, social, professional and scientific framework, touching upon the transferability of project results**

My graduation project is a response to the two emerging anthropocentric phenomenon in the modern society, the prosumer concept and the innovative culture. The rapid development of ICT (Information and Communication Technology) encourages the general public to be a prosumer (a person who both produces and consumes a product) of cultural products, for instance we can watch and upload videos in YouTube. The idea of “prosumer” first appeared in Alvin Toffler’s book in 1980, *The Third Wave*, in which Toffler compares the agricultural society as the First Wave; the industrial Age as the Second Wave and the Information Age as the Third Wave. He predicts while in the Third Wave, the role of producers and consumers would be blurred and merged. The maker library provides the opportunity for people to be a prosumer of cultural products. People can learn how to create videos, audios, digital codes, artworks, models, to name but a few using the equipment given in the library. They are consuming the knowledge and creating cultural products which inspire the learning of the others at the same time. Through the simultaneous production and consumption of knowledge stimulates the growing innovative culture in the Netherlands. (Netherlands was ranked as the fourth country in the Global Innovation Index in 2015 and promoted to the second place in 2018. ) Many municipalities in the Netherlands have expressed interest in cultivating innovation spaces. The methodology of research that I employed in my thesis is a proposal that instigates the rebirth of old factories, through adapting their typology and structure and preserving the cultural value behind.

The fact that my building is a typical example of factory buildings in the early 20th century provides an in-depth exploration of a possibility in adaptive reuse of heritage through innovation. My graduation project demonstrates the potential of how heritage can evolve and adapt to the future anthropocentric development.

**Discuss the ethical issues and dilemmas you have encountered in (i) doing the research (ii) if applicable, elaborating on the design and (iii) potentials of the results in public.**

The greatest ethical issue and dilemma that I encountered in the research and design process is in the decision making process of what and how much should preserve. During the cultural value workshop, we have completed the value matrix developed from the works of Rigel and Brand . Although the studio has provided the very structured framework to assess the cultural value, in the end the interpretation and the resulting product are always up to the architect's personal evaluation. The new time layer created may alter or even shatter the quality of the heritage. The building fabrics that have to be demolished in order to make way for the intervention can cause a loss in cultural value to the future generation.

Despite the difficult situation in balancing the new and the old, I still made my decision with determination. I believe that heritages are relics of the past, and they tell the history of the world. It is in the architect's responsibility to see the potential in forgotten and faded spaces, and give it another life. In this manner, beyond contributing to sustainability through up-cycling old buildings, architects can also preserve an invaluable part of our cultural heritage.

*Literature:*

*Toffler, Alvin. The Third Wave. New York: Bantam Books, 1980.*

*GLOBAL INNOVATION INDEX 2018: Energizing the World with Innovation. Place of Publication Not Identified: WORLD INTELLECTUAL PROPER, 2018.*

