

Closing carbon cycles

Evaluating the performance of multi-product CO₂ utilisation and storage configurations in a refinery

Fernández-Dacosta, Cora; Stojcheva, Viktorija; Ramirez, Andrea

DOI

[10.1016/j.jcou.2017.11.008](https://doi.org/10.1016/j.jcou.2017.11.008)

Publication date

2018

Document Version

Final published version

Published in

Journal of CO₂ Utilization

Citation (APA)

Fernández-Dacosta, C., Stojcheva, V., & Ramirez, A. (2018). Closing carbon cycles: Evaluating the performance of multi-product CO₂ utilisation and storage configurations in a refinery. *Journal of CO₂ Utilization*, 23, 128-142. <https://doi.org/10.1016/j.jcou.2017.11.008>

Important note

To cite this publication, please use the final published version (if applicable). Please check the document version above.

Copyright

Other than for strictly personal use, it is not permitted to download, forward or distribute the text or part of it, without the consent of the author(s) and/or copyright holder(s), unless the work is under an open content license such as Creative Commons.

Takedown policy

Please contact us and provide details if you believe this document breaches copyrights. We will remove access to the work immediately and investigate your claim.

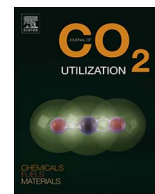

Closing carbon cycles: Evaluating the performance of multi-product CO₂ utilisation and storage configurations in a refinery



Cora Fernández-Dacosta^{*}, Viktorija Stojcheva¹, Andrea Ramirez²

Copernicus Institute of Sustainable Development, Utrecht University, Heidelberglaan 2, 3584 CS Utrecht, The Netherlands

ARTICLE INFO

Keywords:

Multi-product CO₂ utilisation
Cascade and parallel configurations
Dimethyl ether
Polyol
Closing carbon cycles
Life cycle assessment

ABSTRACT

Carbon capture and utilisation (CCU) has the potential to provide business cases as CO₂ waste streams are turned into feedstock for the synthesis of marketable products. Although CCU could reduce fossil resource demand, its capability as a climate change mitigation option is under debate. In contrast to single-product CCU, this prospective study explores the techno-economic and environmental feasibility of novel systems that include more than one CO₂ utilisation product. The combination of multi-product CCU with CO₂ storage is also investigated. Two configurations have been designed, in which CO₂ is captured in a refinery and converted into dimethyl ether (DME) and polyols, simultaneously (*parallel* configuration) or in two consecutive cycles (*cascade* configuration).

Compared to a reference system without capture, results show that the largest direct CO₂ emission reductions are achieved with CCS without utilisation (−70%) but at the expenses of higher total costs (+7%). Multi-product CCU systems show lower fossil depletion and costs than the reference without capture (−10% and −9%, respectively) because of feedstock replacement by the CO₂ utilised. Combination of multi-product CCU with storage turns to be the best alternative for reduced climate change potential (−18% relative to the reference) while still been economically feasible. In addition to lower upstream emissions due to fossil feedstock replacement by utilising CO₂, process direct emissions diminish owing to storage. No significant differences were found between the cascade and the parallel configurations. The extra effort to recycle CO₂ in the cascade configurations is neither penalised nor rewarded.

1. Introduction

Carbon capture and utilisation (CCU) concepts are increasingly been researched, since in addition to reduce CO₂ emissions they could result in lower fossil resource demand [1,2]. Moreover, the large capital investment associated with carbon capture could (partially) be compensated because CO₂ is converted into valuable products that provide revenues [3,4]. However, the potential of CCU as a pathway to obtain large emission reductions has been debated, due to the short CO₂ storage time of many applications, and the difficulties to assess potential displacement effects.

Previous literature studies have investigated CCU options mainly focusing in CO₂ conversion into fuels including techno-economic aspects and simple carbon metrics. These studies show that the production of liquid hydrocarbon fuels with commercially proven CCU technology is not yet economically viable [5]. Methanol synthesis from CO₂ and renewable hydrogen from electrolysis is only economically feasible for large plant capacity, when by-products are sold and methanol has a high selling price [6], or when the feedstock costs are lower and the CO₂ value is high [7]. However, methanol production from captured CO₂ has the potential of net reduction of CO₂ emissions mainly due to the fossil fuel avoided compared to the conventional MeOH synthesis

Abbreviations: ACC, annualised capital costs; Capex, capital expenditures; CC, climate change; CCS, carbon capture and storage; CCU, carbon capture and utilisation; CCUS, carbon capture utilisation and storage; CEPCL, chemical engineering plant cost index; cPC, cyclic propylene carbonate; CTS, compression transport and storage (of CO₂); DMC, double metal cyanide; DME, dimethyl ether; DOC, direct operating costs; FCC, fixed capital costs; FD, fossil depletion; FOC, fixed operating costs; FU, functional unit; G, glycerol; GHG, greenhouse gas; IOC, indirect operating costs; LCA, life cycle assessment; LCI, life cycle inventory; MDEA, methyl diethanolamine; MEA, monoethanolamine; MPG, monopropylene glycol; NG, natural gas; NPV, net present value; Opex, operation expenditures; PA, produced amount; PCE, purchased cost of equipment; PO, propylene oxide; PP, purchase price; PSA, pressure swing adsorption; SA, system area; SMR, steam methane reforming; VOC, variable operatic costs; WCC, working capital costs; WGS, water gas shift

^{*} Corresponding author.

E-mail addresses: C.FernandezDacosta@uu.nl (C. Fernández-Dacosta), v.stojcheva@ecofys.com (V. Stojcheva), c.a.ramirezramirez@tudelft.nl (A. Ramirez).

¹ Current address: Ecofys Netherlands, Kanaalweg 15-G, 3526 KL, Utrecht, The Netherlands.

² Current address: Department of Engineering, Systems and Services, Faculty of Technology, Policy and Management, Delft University of Technology, Jaffalaan 5, 2628 BX Delft, The Netherlands.

<https://doi.org/10.1016/j.jcou.2017.11.008>

Received 30 August 2017; Received in revised form 20 October 2017; Accepted 21 November 2017

Available online 18 December 2017

2212-9820/ © 2017 The Authors. Published by Elsevier Ltd. This is an open access article under the CC BY license (<http://creativecommons.org/licenses/by/4.0/>).

process. Other CCU options consider formic acid as final product, which can be used as hydrogen carrier or as fuel for fuel cells [8]. When using renewable electricity and steam, this CO₂ utilisation alternative has lower CO₂ emissions than the corresponding conventional process. In spite of its environmental attractiveness and technical feasibility, CO₂-based formic acid is not yet financially attractive.

CCU has been typically regarded as a technology towards a single end product. The earlier studies indicated that the major drawback is a no yet economically practicability. However, integrated CO₂ conversion into multiple fuels and chemicals in the same facility could benefit from synergies, such as process and equipment integration and more efficient energy and resource use, analogous to the refinery concept. System-wide and detailed assessments of CCU configurations for co-production of fuels and chemicals are not available in literature.

This paper aims to assess whether configurations that combine multi-product carbon capture and utilisation (CCU) and multi-product carbon capture, utilisation and storage (CCUS), are feasible concepts to close carbon cycles in the petrochemical industry. In this study, we investigate the potential benefits and trade-offs of such multi-output configurations.

To answer the research goal, a case study in a refinery was used, where CO₂ is captured at a steam methane reforming (SMR) facility and is utilised into dimethyl ether (DME) and polyols, different target products than those that received more attention in preceding research (*i.e.*, methanol). This case was selected as:

- SMR processes contribute to 20% of the CO₂ emissions at refineries, and refineries account for 10% of the global industrial CO₂ emissions [9].
- CO₂ conversion into fuels is considered as an attractive option to achieve large CO₂ emissions reduction due to its high fuel global market demand (100-times higher than that of chemicals; [10]. Whereas liquid hydrocarbon fuels, methanol or formic acid are still not economically attractive [5,7,8,6], DME has been reported as a cost-effective option to replace conventional transportation fuels [11,12]. Moreover, DME is a sulfur-free fuel with higher cetane number than diesel and leads to very low emissions of particulate matter, NO_x, and CO during its combustion [13]. CO₂-based DME appears as a more efficient alternative compared to conventional DME synthesis [14]. CO₂ is used in a methane dry reforming process to produce syngas, which is then directly transformed into DME [15]. This option has large market potential but the CO₂ is stored for a short period of time.
- The second product in the configuration considers CO₂ conversion into chemicals. Urea and salicylic acid synthesis using CO₂ are well-established industrial processes [3]. CO₂-based polyols are a CCU alternative with high potential for market growth, so they can contribute to meet emissions reduction targets. These polyols are already at commercial stage [16,17] and used as precursors of polyurethane flexible foams. The CO₂ incorporated into the polyol is limited to 20 wt% in order to meet the right flexibility of the final product [18]. This option has a lower market potential than fuels but the CO₂ is stored for a longer period of time (decades vs. days).

Process modelling of the commercial-scale CO₂ source (SMR unit in the refinery), the CO₂ capture unit and CO₂ conversion processes (DME and polyols) serves as basis for an integrated techno-economic and environmental assessment. The environmental evaluation follows a life cycle-assessment approach incorporating climate change and fossil depletion indicators since fuel savings could be a relevant benefit of CCU options (Pérez-Fortes et al., [6]. A comparison among the different CCU and CCUS configurations is carried out to identify the economic and environmental hotspots of each system.

2. Methodology

2.1. Scoping

For the purpose of assessing multi-product CCU and multi-product CCUS systems, two configurations were defined. The CO₂ source in all cases is a hydrogen manufacturing unit of a refinery equipped with carbon capture. In the first configuration (*parallel*) the synthesis of DME and polyol happens in parallel, using the CO₂ stream captured at the hydrogen unit. In the second configuration (*cascade*) the CO₂ captured in the hydrogen unit is first used in the synthesis of DME. The CO₂ released during DME processing is then re-captured and used as feed-stock for polyols synthesis. In addition, two reference configurations were considered. One reference case consisting of H₂ production at the refinery without carbon capture, and a storage case that only incorporates CO₂ capture, transport and storage. In total, six different systems were defined (see below). Note that it is assumed that the CCU products would displace fossil based counterparts, and therefore in the systems where there is no utilisation (*REF* and *CCS* cases), DME and polyol are still produced but in the conventional manner.

- **Case 1. Reference (REF):** H₂ unit of a refinery without CO₂ capture + conventional DME + conventional polyol production (no CO₂ utilisation).
- **Case 2. Storage-only (CCS):** H₂ unit of a refinery with CO₂ capture and storage + conventional DME + conventional polyol production (no CO₂ utilisation).
- **Case 3. Multi-product CCU, Parallel:** H₂ unit of a refinery with CO₂ capture + CO₂-based DME + CO₂-based polyol production. After capture, the CO₂ stream is split into two parts. One part of the CO₂ is used for CO₂-based polyol synthesis and the rest is used for CO₂-based DME production. There is no CO₂ storage.
- **Case 4. Multi-product CCU, Cascade:** H₂ unit of a refinery with CO₂ capture + CO₂-based DME + CO₂-based polyol production. The CO₂ captured from the H₂ unit is first used for DME production. During DME production 90% of the used CO₂ is re-emitted [19]. Part of the CO₂ released in the DME process is then re-captured, and utilised in CO₂-based polyol synthesis. The rest of the CO₂ is released to the atmosphere. There is no CO₂ storage.
- **Case 5. Multi-product CCUS, Parallel:** H₂ unit of a refinery with CO₂ capture + CO₂-based DME + CO₂-based polyol production. After capture, the CO₂ stream is split into two parts. One part of the CO₂ is used for CO₂-based polyol synthesis and the rest is used for CO₂-based DME production. The CO₂ released during DME synthesis is re-captured and sent to storage.
- **Case 6. Multi-product CCUS, Cascade:** H₂ unit of a refinery with CO₂ capture + CO₂-based DME + CO₂-based polyol production. The CO₂ captured from the H₂ unit is first used for DME production. The CO₂ released in the DME process is then re-captured, a part of it is utilised for CO₂-based polyol synthesis and the rest is stored.

The total systems were divided into system areas (SA) as shown in Fig. 1 and Table 1. Each SA corresponds to a part of the value chain or process type (*e.g.*, natural gas production and transport, hydrogen manufacturing unit, polyol synthesis, etc.). The division on SAs allows transparently communicate differences in the type and level of modelling complexity among SAs and clearly identify the sub-processes with the largest contributions to the costs and environmental impacts.

In all cases, three final products (H₂, DME and polyol) are produced. To size the configuration we chose a SMR unit with a typical commercial-scale production capacity (59 kt/a of hydrogen; [20,21]. From this unit, 95% of the direct CO₂ emissions (337 CO₂ kt/a) are captured via chemical absorption [21]. CO₂-DME synthesis requires 1.76 kg CO₂/kg of DME [19], thus 192 kt/a CO₂-DME could be produced from the CO₂ captured at the SMR unit. Because it is not realistic to have a plant that uses all the CO₂ for polyol, we assumed the capacity of the

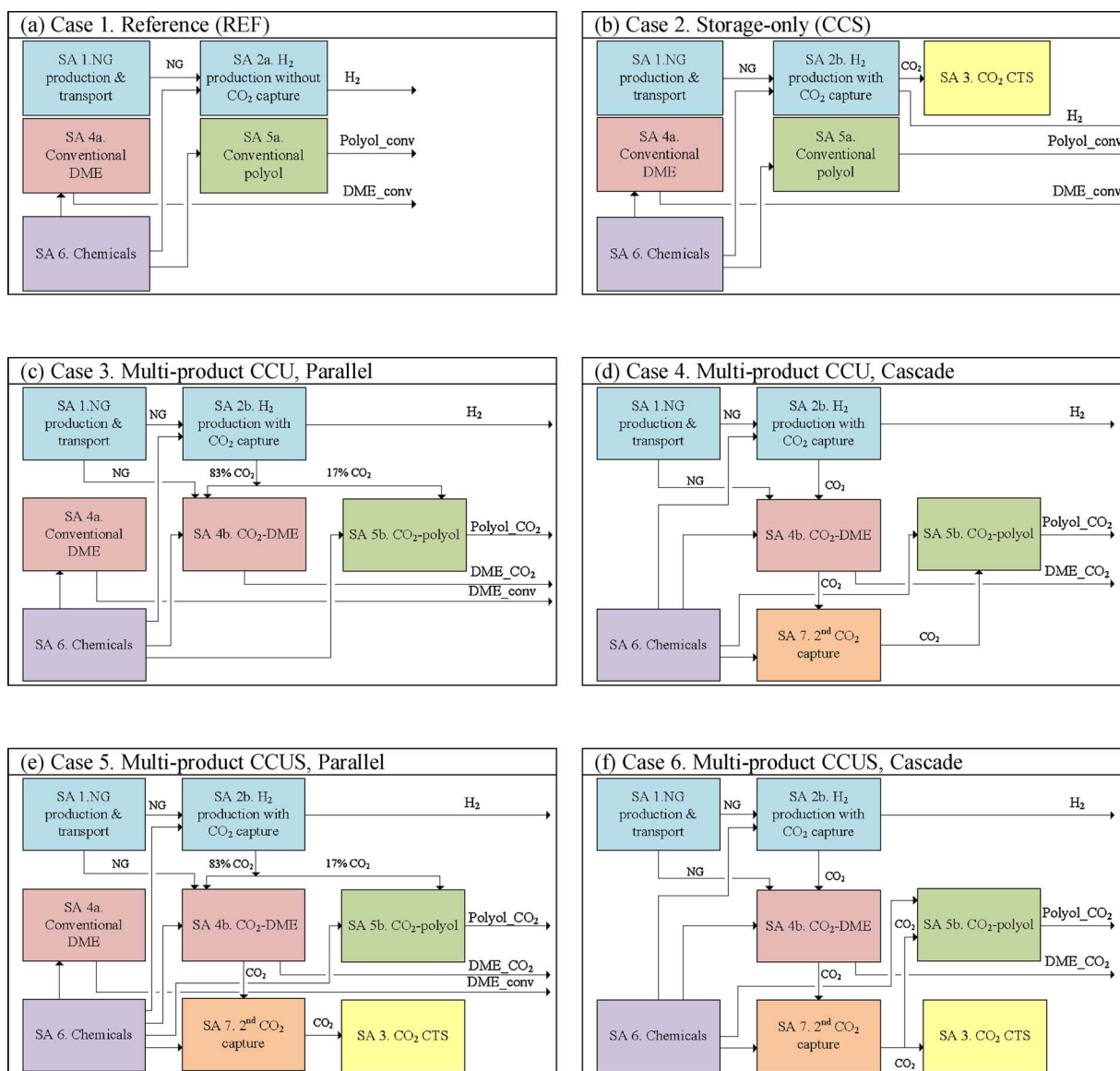

Fig. 1. Schematic process layout of the case studies. (a) Case 1. Reference (REF), (b) Case 2. Storage-only (CCS), (c) Case 3. Multi-product CCU, Parallel, (d) Case 4. Multi-product CCU, Cascade, (e) Case 5. Multi-product CCUS, Parallel, (f) Case 6. Multi-product CCUS, Cascade. NG: natural gas; Conv: conventional; CTS: carbon transport and storage.

Table 1
System areas included in the case studies and process capacities.

System areas	No utilisation		Multi-product CCU		Multi-product CCUS	
	1. REF	2. CCS- only	3. Parallel	4. Cascade	5. Parallel	6. Cascade
SA 1. NG production and transport	✓	✓	✓	✓	✓	✓
SA 2a. H ₂ production without CO ₂ capture	✓	–	–	–	–	–
SA 2b. H ₂ production with CO ₂ capture	–	✓	✓	✓	✓	✓
SA 3. CO ₂ compression, transport and storage (CTS)	–	✓	–	–	✓	✓
SA 4a. Conventional DME	✓	✓	✓	–	✓	–
SA 4b. CO ₂ -based DME	–	–	✓	✓	✓	✓
SA 5a. Conventional polyol	✓	✓	–	–	–	–
SA 5b. CO ₂ -based polyol	–	–	✓	✓	✓	✓
SA 6. Chemicals	✓	✓	✓	✓	✓	✓
SA 7. 2nd capture unit	–	–	–	✓	✓	✓
Process capacity (kt/a)						
H ₂ (kt/a)	59	59	59	59	59	59
DME _{conventional} (kt/a)	192	192	33	–	33	–
DME _{CO₂} (kt/a)	–	–	159	192	159	192
Polyol _{conventional} (kt/a)	250	250	–	–	–	–
Polyol _{CO₂} (kt/a)	–	–	250	250	250	250

polyol process to be 250 kt/a, based on a commercial scale plant [22]. For a fair comparison of the performances among the six case studies, the same process capacities were used regardless of whether the final products are produced from CO₂ or fossil fuels (Table 1).

Note that a particular situation occurs for DME production in the parallel configurations (cases 3 and 5). These are utilisation cases, and therefore all DME should be CO₂ based. However, in these configurations, the CO₂ captured from the H₂ unit is also used for polyols synthesis resulting in a lower availability of CO₂ for DME synthesis (compared with the cascade cases, in which all CO₂ captured at the H₂ unit is converted into DME). To maintain the same final product output as in the other systems, in the parallel cases 159 kt/a DME are produced from the CO₂ available and the deficit is compensated by conventional DME (33 kt/a DME), (Table 1).

2.2. Process assessment

The mass and energy balances and equipment list of the production processes of hydrogen, DME and polyol, the CO₂ capture units and CO₂ compression before transport and storage were based on previous in-house research [21,19,23,22]. These models were developed based on the scope of the assessment, the state of the art literature review and an evaluation of the knowledge base available, which determined the level of detail and complexity of each model. The details on the process models are briefly described in this section.

No specific models were developed for SA 1. NG production and transport, SA 6. Chemicals and CO₂ transport and storage of SA 3. The amounts of NG, chemicals and CO₂ included in these system areas were determined from the mass of NG and chemicals needed and CO₂ produced in the other system areas.

2.2.1. H₂ production

Hydrogen production via SMR is a well-known established process. In this process, methane and steam are pre-heated and fed to the reformer (560 °C, 30 bar), (Fig. 2a). The syngas is further converted to H₂ and CO₂ in a water gas shift (WGS) reactor (400 °C, 25 bar). The stream from the WGS reactor (220 °C, 25 bar) contains some water, which is removed, so only CO₂ and H₂ enter the pressure swing adsorption unit (PSA). In the PSA unit (220 °C, 25 bar), H₂ is obtained as main product, while the offgas is burned in the furnace section of the reformer to aid

the endothermic reaction. The extra heat available after the reforming reaction is used for steam generation. The specific SMR models for the H₂ unit included in this study were developed in Aspen Plus V8.4. based on [22].

2.2.2. CO₂ capture and compression

The CO₂ capture unit in the SMR facility was adapted from Meerman et al. [21], which identified the optimal techno-economic configuration of CO₂ capture at SMR facilities using currently available technologies. The authors indicated that the most efficient location for the capture unit is after the WGS reactor (Fig. 2b). For solvent selection, energy requirement, loading capacity, corrosiveness, vapour pressure and chemical stability were analysed. In consultation with industry experts, ADIP-X solvent (a mixture of methyl diethanolamine (MDEA) and piperazine in water) was selected to capture 95% of the overall CO₂ produced in the WGS reaction.

In the cascade and CCUS-Parallel case studies, the CO₂ released in the synthesis of CO₂-DME is re-captured in a second unit (SA 7). The CO₂ concentration in this stream is 33 mol% (as opposed to 20 mol% in the first capture unit). Instead of using the very specific model of the first capture unit (developed to capture CO₂ after WGS in SMR units), the second capture unit was modelled based on a generic model using more conventional MEA solvent to capture 90% of the CO₂ [23]. The steam demand in the reboilers of both capture units is covered by the steam generated in the H₂ unit (Section 2.2.1).

The CO₂ captured is then compressed to 110 bar for transport via pipeline to an offshore aquifer, where it is stored. The compression train is made up of four compression stages with intermediate cooling and a final pump (Fig. 2b). Specific compression trains for the different case studies were modelled in Aspen Plus V8.4.

2.2.3. DME production

The Aspen Plus models of conventional DME and CO₂-DME production processes developed in Schakel et al. [19] have been used in the current study. In the conventional route for the synthesis of DME, liquid methanol is pre-heated to 160 °C and fed to the dehydration reactor, where it is directly converted to DME at 15 bar of pressure (Fig. 3a). After the reaction, the produced DME, the water and the unconverted methanol are depressurized to 10 bar and cooled down to 50 °C. This mixed stream is fed to a distillation column. DME at > 99.5% is

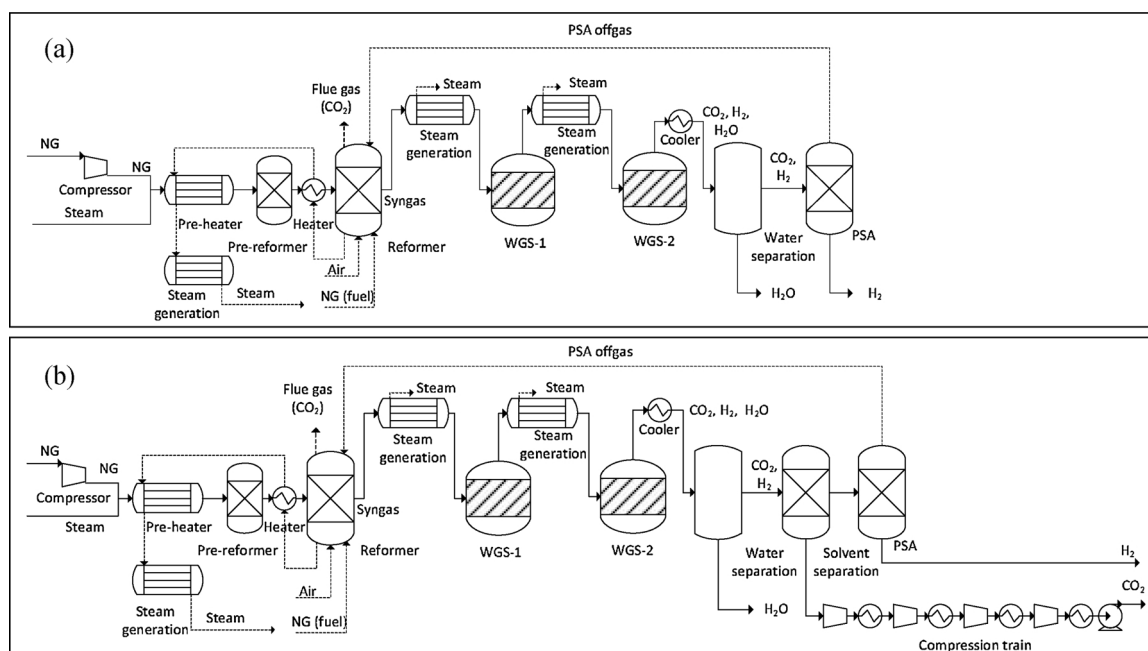

Fig. 2. Flow diagram of H₂ production at refinery via SMR (a) no CO₂ capture, (b) CO₂ capture and compression.

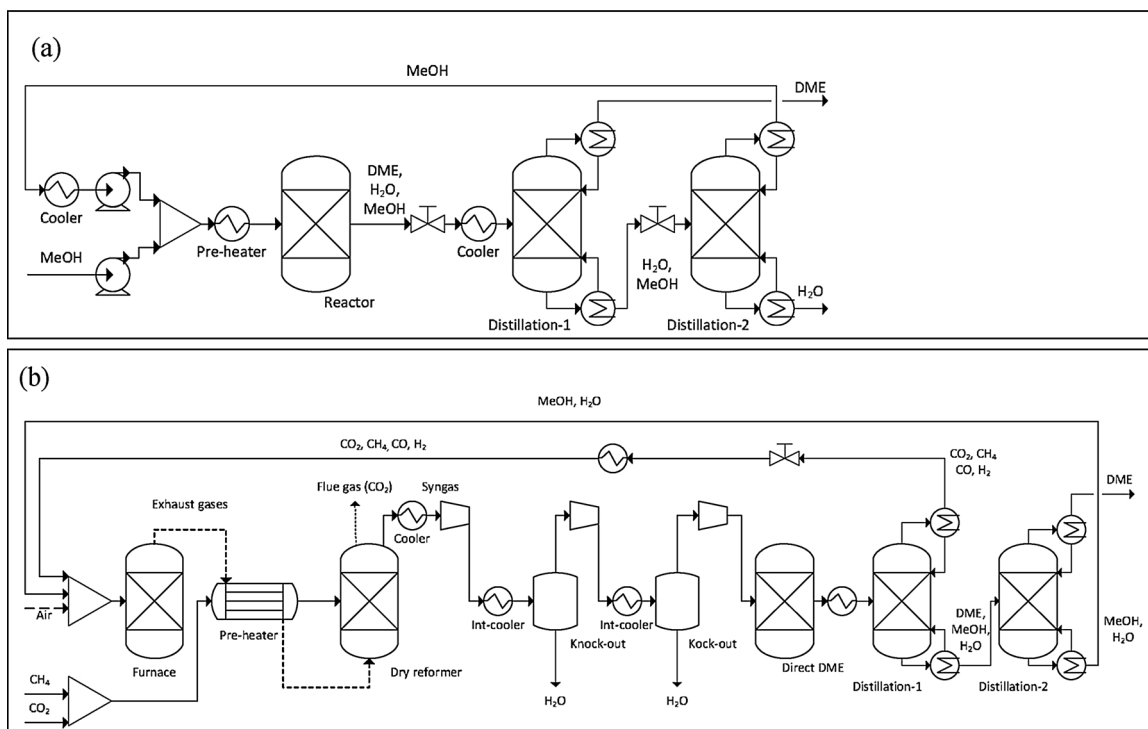

Fig. 3. Flow diagram of DME production. (a) Conventional DME via methanol dehydration, (b) CO₂-based DME via methane dry reforming.

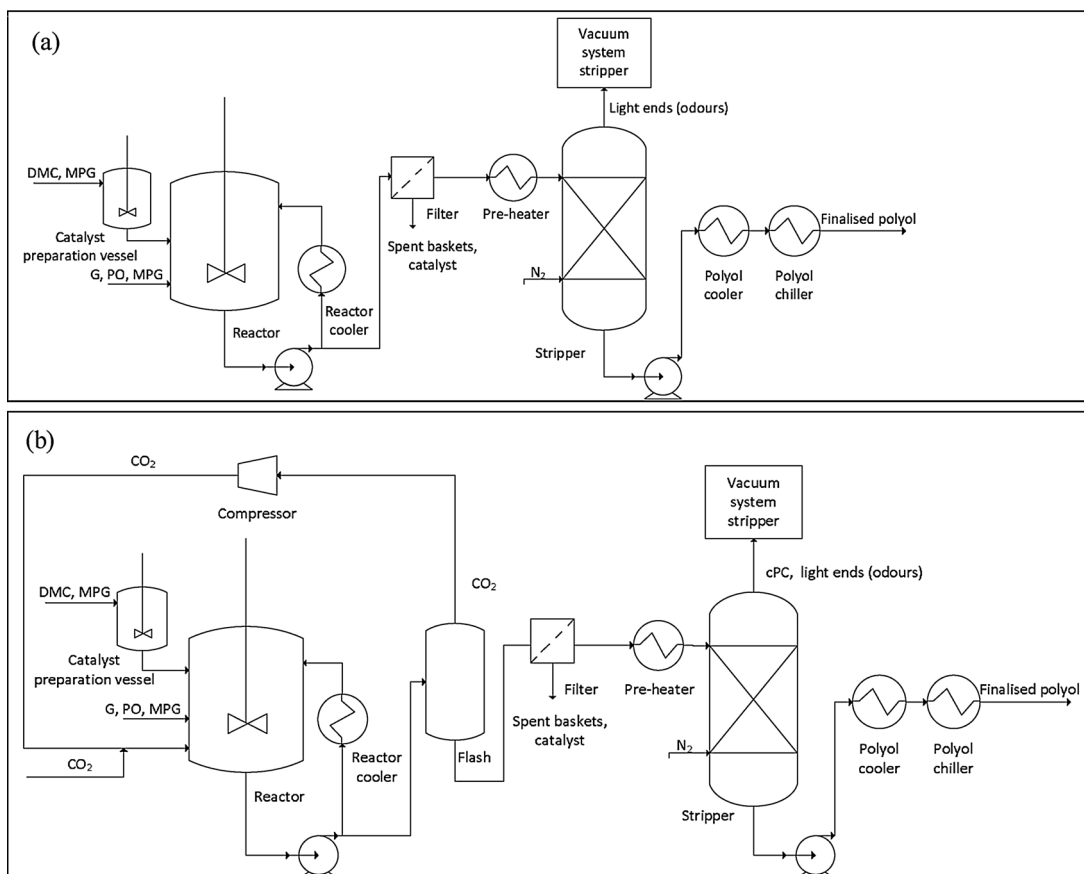

Fig. 4. Flow diagram of polyol synthesis. (a) Conventional, (b) CO₂-based polyol.

obtained at the top of the column (45 °C, 10 bar). The methanol and water leaving at the bottoms (157 °C, 10 bar) are fed into a second distillation column, where the methanol is recovered at the top (123 °C,

7 bar) and is liquefied (90 °C) and recycled to the dehydration reactor. Complete details can be found in Schakel et al. [19].

In the CO₂-based DME production process CO₂ and methane are pre-

heated and fed to the dry reforming reactor (800 °C, 2 bar), (Fig. 3b). The syngas leaving the reactor is cooled down and compressed to 79 bar for direct DME synthesis (250 °C). Methanol, syngas, water, CO₂ and methane are the impurities leaving the direct DME reactor. After depressurization to 10 bar and cooling down to 32 °C, this stream is fed to a distillation column. CO₂, CH₄, CO and H₂ are separated at the top of the column (−48 °C, 10 bar). DME, methanol and water leaving the column at the bottom (45 °C, 10 bar) are directed to a second distillation column to obtain highly pure DME (> 99.5%, 40 °C). The syngas, methane and CO₂ separated at the top of the first distillation column, together with the methanol and water stream separated at the bottom of the second column (70 °C, 10 bar), are fed to a furnace and burnt for heat recovery.

In the parallel configurations, the flue gas stream containing CO₂ is either directly released to the atmosphere (case 3. *CCU-Parallel*) or captured and sent to storage (case 5. *CCUS-Parallel*). In case 4. *CCU-Cascade*, only the amount of CO₂ needed for polyol synthesis is captured and the rest is released to the atmosphere. However, in case 6. *CCUS-Cascade* all CO₂ from the DME process is captured. Partly is used in polyol synthesis and the rest is stored.

2.2.4. Polyol production

The models for polyol synthesis developed in Fernández-Dacosta et al. [22] were used in the present study. These spreadsheet models of the conventional polyol processes were built upon input data on reaction parameters, polyol properties and process line-ups described by industrial experts. Due to the novelty of the process and lack of real process data available, the CO₂-based polyol model was based on literature [24–26] and patents [27–29].

Conventional polyethercarbonate polyol (PPC) is produced from the reaction of propylene oxide (PO), glycerol (G) and monopropylene glycol (MPG), which takes place at 135 °C and 3 bar (Fig. 4a). Double metal cyanide (DMC) is used as catalyst and recovered in a filter after the reaction. In a vacuum-stripping step (140 °C, 25 mbar) odours and other impurities are separated, and polyol is obtained as final product (40 °C, 1 bar).

PO, MPG and glycerol are also starting materials for the synthesis of CO₂-based polyol. However, part of the PO needed in the conventional process is replaced by CO₂ (Fig. 4b). The maximum content of CO₂ in the final product polyol is 20 wt% to ensure the right flexibility for flexible foam application [16]. After the reaction (135 °C, 20 bar), the CO₂ that has not been converted to polyol is flashed out at 3 bar and recycled. The by-product cyclic propylene carbonate (CPC) is removed with the odours in the vacuum stripping step (140 °C, 25 mbar), and thus polyol at 99.9 wt% is obtained as final product (40 °C, 1 bar). For full details of the models see Fernández-Dacosta et al. [22].

2.3. Economic evaluation

Based on the equipment sizes and mass and energy balances from the process models, capital and operational costs were calculated for each of the systems investigated. Capital costs and operational costs were used to determine the total systems costs and net present value (NPV). Finally, H₂, DME and polyol costs were calculated per case study to evaluate how the introduction of CO₂ capture units would affect the final products costs.

The geographical location of this analysis is North West Europe, the scope is 20 years, and the reference year is 2016. Cost data was corrected for inflation using the Consumer Price Index (CPI) for the raw materials and the Chemical Engineering Plant Cost Index (CEPCI) for the equipment. To convert US\$ to €, an exchange rate of 1.11 US\$/€ was used [30].

2.3.1. Capital and operational costs

Capital expenditure (Capex) is divided into fixed capital costs (FCC)

and working capital costs (WCC). FCC are the initial investment needed to build the plant and the WCC are the additional investment needed to start up the plant. FCC were estimated using the factorial method (Eq. (1) and Eq. (2) from [31]). In this method, the capital costs are estimated based on the purchased cost of equipment (PCE), and the physical plant costs (PPC). The cost items that contribute to the FCC are estimated as factors of the PCE (f1 to f12 in Eq. (2)). The factors per cost item used in this study are shown in the Supplementary material (S.2.1). The WCC was assumed 15% of the FCC [31].

$$FCC = PPC \cdot (1 + f_{10} + f_{11} + f_{12}) \quad (1)$$

$$PPC = PCE \cdot (1 + f_1 + f_2 + \dots + f_9) \quad (2)$$

The PCE was estimated applying the exponent method [32]. In this method a cost correlation (Eq. (3)) is used that relates specific cost constants (a, b) and exponents for each type of equipment (c) with its characteristic size (S).

$$PCE = a + b \cdot S^c \quad (3)$$

The characteristic sizes of the equipment were derived from the process assessment. For some sub-process, the capacity varies depending on the case study. Since the equipment of these sub-processes are the same regardless the case study, equipment sizes were adjusted using the exponent method Towler and Sinot, [32]. A typical scale exponent of 0.65 for petrochemical processes was used in this study. Specific details of the PCE estimation are reported in the Supplementary material (S.2.1).

The total operational expenditure (Opex) consists of indirect (IOC) and direct operating costs, which in turn are divided into fixed (FOC) and variable operating costs (VOC), Eq. (4):

$$Opex = FOC + VOC + IOC \quad (4)$$

Fixed operating costs include maintenance, capital charges, rates, insurance, license fees and royalty payments. These costs are estimated as a percentage of the FCC. Labour costs are also a fixed operating expenditure and estimated as a percentage of the total production costs. Laboratory, supervision and plant overheads costs are based on labour costs Sinnott, 2005. The specific percentages assumed for the FOC estimation are described in the Supplementary material (S.2.1). The indirect operating costs were assumed 25% of the direct operating costs [31].

Variable operating costs cover raw materials, utilities and miscellaneous operating material costs. Miscellaneous operating materials are plant supplies required to operate the plant such as safety clothing, instrument charts and accessories, pipe gaskets or cleaning materials. Miscellaneous materials were assumed 10% of maintenance costs [31]. Raw materials and utilities costs were estimated based on the mass balances (from the process assessment) and the material prices. Utilities prices were estimated based on the correlations proposed by Ulrich and Vasudevan [33] and the industrial gas price of 2016 [34]. Raw materials prices used in this study are shown in Appendix A. Specific details in the estimation of raw materials prices are reported in the Supplementary material (S.2.2).

Natural gas (NG) production and transport only has operational costs made up of the costs for NG exploration, operation, transportation, storage and refueling. These costs were adopted from IEA [35] and [36]. CO₂ transport and storage costs were taken from ZEP [37–39]. It is assumed that the CO₂ is transported a total distance of 100 km, 5 km onshore to the port and 95 km offshore to the saline aquifer where it is stored. Specific costs used in this study and details in the calculation of CO₂ transport and storage costs and NG production and transport costs are shown in the Supplementary material (S.2.3).

2.3.2. Total system costs and NPV

Total costs were estimated as the sum of the annualised Capex plus

Opex. 20 years of plant lifetime (n) and a discount rate (d) of 10% were assumed to annualise the capital costs (ACC) following Eq. (5) Towler and Sinot, [32]:

$$ACC = \frac{d*(1+d)^n}{(1+d)^n - 1} * FCC \quad (5)$$

The NPV was calculated based on the initial investment (I), which equals the total Capex and the net cash inflow expected to be received in each period (R), Eq. (6).

$$NPV = \sum_1^n \frac{R}{(1+d)^n} - I \quad (6)$$

The net cash inflows were calculated based on the purchase price of the products (PP, Appendix A) and their annual produced amount (PA, process capacity in Table 1) (Eq. (7)):

$$R = PP_{H_2} * PA_{H_2} + PP_{DME} * PA_{DME} + PP_{polyol} * PA_{polyol} \quad (7)$$

2.3.3. Final product costs

Besides estimating total costs at system level, the final product costs (H₂, DME and polyol) were calculated. Final product costs were estimated by adding the costs of the system areas needed for the production of each product (Fig. 1) and dividing it by its total production capacity (Table 1). Capture costs were allocated to the CO₂ source or to the CO₂ product, taking into account whether the main purpose of the CO₂ capture unit was storage or utilisation. The assumptions to estimate final product costs based on mitigation/utilisation goals were:

- Case 2. CCS: CO₂ from the H₂ unit at the refinery is captured, transported and stored for mitigation goals. Therefore, capture, transport and storage costs are allocated to H₂.
- Case 3. CCU-Parallel: CO₂ from the H₂ unit at the refinery is solely captured for utilisation goals. Thus, capture costs are allocated to the utilisation products *i.e.*, CO₂-DME and CO₂-polyol, based on the mass of CO₂ incorporated to each product.
- Case 4. CCU-Cascade: CO₂ from the H₂ unit at the refinery is captured and utilised in CO₂-DME synthesis. The costs of this capture unit are completely allocated to CO₂-DME. A second capture unit only captures the CO₂ emitted during CO₂-DME production that is used in the synthesis of CO₂-polyol. Consequently, cost of this unit is allocated to the CO₂-polyol.
- Case 5. CCUS-Parallel: as in case 3. *CCU-Parallel*, the costs of the first capture unit are allocated to CO₂-DME and CO₂-polyol based on the mass of CO₂ incorporated in each product. In this CCUS case, the CO₂ emitted during CO₂-DME production is captured in a second capture unit and transported to storage for mitigation purposes. Thus, CO₂-DME pays for the second CO₂ capture unit, transport and storage.
- Case 6. CCUS-Cascade: as in case 4. *CCU-Cascade*, CO₂-DME pays for the first capture unit. A second capture unit captures all CO₂ emitted during CO₂-DME production. Part of the CO₂ captured in this second unit is used in the synthesis of CO₂-polyol and the rest is sent to storage. Therefore, the costs of the second capture unit are allocated to CO₂-polyol, based on the mass of CO₂ incorporated to the polyol and to CO₂-DME, based on the amount of CO₂ sent to storage. CO₂-DME pays for the transport and storage.

The equations used to estimate the final product costs in each case study and the allocation factors used are in the Supplementary material (S.2.4).

2.4. Environmental assessment

Given the complexity of the systems and the explorative approach of this research, two impact categories *i.e.*, climate change (CC), fossil

depletion (FD) were estimated following a cradle to gate life cycle assessment (LCA) perspective.

One of the most challenging aspects for LCA of multi-output configurations is the selection of the functional unit. In this research, a system expansion approach was used by defining a harmonized basket of products (H₂, DME and polyol), which are produced in the same amounts in all systems. To create this harmonized basket of products, the departure point is 1 MJ of H₂ produced at the refinery. The amount of CO₂ captured per MJ of H₂ produced is calculated, and based on this CO₂ captured, the corresponding amounts of CO₂-DME and CO₂-polyol produced were estimated. The functional unit used in the LCA is therefore 1 MJ H₂ + 0.78 MJ DME + 0.04 kg polyol.

Material and energy balances from the process assessment were used as input to create a life cycle inventory (LCI). The LCI was combined with system process data from Ecoinvent 3. The ReCiPe impact characterization method was used [40] with a hierarchist perspective (ReCiPe Midpoint (H) v1.12) and European normalization (Europe Recipe H).

Key assumptions taken for the environmental assessment are shown below (a complete list of assumptions is in Appendix B):

- Heat integration in the H₂ unit generates steam, which is used to cover the steam demand in the capture units and in the DME and polyol processes. The surplus of steam is credited Schwarz et al., 2002.
- Methane fugitive emissions from upstream natural gas production processes are included in the LCA, as they are reported to contribute to large impacts on the overall greenhouse gas emissions (GHG) of a fossil fuel based production process [41], Appendix B).
- Impacts of chemical plant infrastructure are excluded from the analysis due to limited data available and because the share of these impacts is typically small in this sector [26].
- The impacts of NG and CO₂ transport and storage infrastructure are included in the LCA (Appendix B).

3. Results

3.1. Process assessment

Table 2 shows the most relevant results, which are discussed in the next sections. Full mass and energy balances of the sub-processes included in each case study are in the Supplementary material (S1).

• CO₂ flows

The largest CO₂ emission reductions are achieved when all CO₂ that is captured is stored (Case 2. *CCS-only*). Direct CO₂ emissions of the CCS system are reduced by 70% compared to the reference case with no carbon capture.

Multi-product CCU systems (cases 3 and 4) show low CO₂ direct emissions reductions compared to the reference case without capture, mainly due to the CO₂ emissions in CO₂-DME synthesis, which accounts for 90% of the CO₂ utilised in this process (337 kt/a). The *CCU-Cascade* configuration (Case 4) has slightly lower CO₂ emissions than the *CCU-Parallel* (Case 3) because a small fraction of the CO₂ released during CO₂-DME synthesis is re-captured in a second unit and used in polyol synthesis.

In order to achieve large mitigation goals, multi-product CCU needs to be combined with storage. Lower amounts of CO₂ are emitted in the CCUS cases compared to the CCU cases because all the CO₂ released in the CO₂-DME process is captured and either stored (Case 5. *CCUS-Parallel*) or partly used in polyol synthesis and partly stored (Case 6. *CCUS-Cascade*). Less CO₂ is captured in the second unit in the *CCUS-Parallel system* (case 5, 230 kt/a) respect to the *CCUS-Cascade* (case 6, 277 kt/a) due to lower CO₂-DME production (Section 2.1).

Table 2
Process assessment results.

	No utilisation		Multi-product CCU		Multi-product CCUS	
	1. REF	2.CCS- only	3. Parallel	4. Cascade	5. Parallel	6. Cascade
Process capacity						
H ₂ (kt/a)	59	59	59	59	59	59
Conventional DME (kt/a)	192	192	33	–	33	–
CO ₂ -DME (kt/a)	–	–	159	192	159	192
Conventional polyol (kt/a)	250	250	–	–	–	–
CO ₂ -polyol (kt/a)	–	–	250	250	250	250
CO₂ flows						
CO ₂ direct emissions (kt/a)	521	158	413	408	183	189
CO ₂ captured 1st unit (kt/a)	–	337	337	337	337	337
CO ₂ utilised 1st unit (kt/a)	–	–	337	377	337	377
CO ₂ stored 1st unit (kt/a)	–	337	–	–	–	–
CO ₂ captured 2nd unit (kt/a)	–	–	–	58	230	277
CO ₂ utilised 2nd unit (kt/a)	–	–	–	58	–	58
CO ₂ stored 2nd unit (kt/a)	–	–	–	–	230	219
Feedstocks						
NG (kt/a)	210	209	310	331	310	331
MeOH (kt/a)	264	264	46	–	46	–
PO (kt/a)	243	243	202	202	202	202
Energy						
Steam; 2.8 MJ/kg (kt/a)	–619	–321	–362	–298	–65	–14
Electricity (GWh/a)	7	38	142	169	168	192

Table 3
Economic assessment results.

Parameter	No utilisation		Multi-product CCU		Multi-product CCUS	
	1. REF	2.CCS- only	3. Parallel	4. Cascade	5. Parallel	6. Cascade
Capex (M€)	128	266	272	287	378	376
Opex (M€/a)	664	694	590	589	618	613
Total costs (M€/a)	677	724	618	618	658	653
NPV (M€)	1527	1132	2009	2006	1669	1714

• Fossil feedstock replacement (NG, MeOH, PO)

One of the advantages of CO₂ utilisation is its potential to displace and therefore reduce fossil resource demand. Propylene oxide (PO) is used as feedstock in the conventional synthesis of polyol (section 2.2.4). In the production of CO₂-based polyol, 17% of PO is replaced by CO₂ (Table 2).

Methanol is used as feedstock in the conventional synthesis of DME (section 2.2.3), and instead of methanol, natural gas is used in the production CO₂-based DME. Therefore, in the CCU and CCUS systems (cases 3 to 6), higher amounts of natural gas are needed (310 to 331 kt NG/a in the CCU and CCUS cases compared to 210 kt NG/a in the REF and CCS cases). No methanol is used in the cascade configurations because all DME production is based on CO₂. However, a small amount of methanol (46 kt/a) is needed in the parallel systems (cases 3 and 5) to produce conventional DME (33 kt/a) in order to keep an equal total DME amount produced among all the case studies (192 kt/a, Section 2.1).

• Energy

In all case studies steam is generated in the hydrogen unit from heat integration (indicated by the minus sign in Table 2). The net steam generated in the REF case is the highest among all cases. The reason is that the steam produced in the hydrogen unit is used to fulfill the demand in the capture units and the production processes. The net steam generated in the CCUS systems (cases 5 and 6) is the lowest (10–2% of the steam generated in the REF case, respectively) because they include a second capture unit after CO₂-DME synthesis. A higher amount of CO₂-DME is produced in the CCUS-Cascade system than in the CCUS-Parallel (Section 2.1). Subsequently more CO₂ is emitted and higher

amount of steam is consumed in the second capture unit. Overall steam generated in the CCU-Cascade system is 18% lower than in the CCU-Parallel system because it includes a small second capture unit that only captures the CO₂ needed for polyol synthesis.

The introduction of a compression train for CO₂ transport to storage increases the electricity demand in the systems including CO₂ storage (cases 2, 5 and 6). The energy required in the CO₂-DME process to compress the syngas leaving the dry reformer reactor to 79 bar for direct DME synthesis (Section 2.2.3) largely increases the electricity consumed in all CCU and CCUS systems. Electricity consumption in the REF and CCS cases is 5% and 27% of the electricity of the CCU and CCUS systems, respectively (Table 2).

3.2. Economic evaluation

3.2.1. Total system costs

The costs at system level are shown in Table 3. All cases have higher Capex than the REF case, being the Capex of the multi-product CCU systems (cases 3 and 4) higher than the CCS-only system (case 2), and the Capex of the multi-product CCUS systems (cases 5 and 6) the highest across all alternatives.

However, only the CCS-only system (case 2) has higher Opex than the REF case because of the energy and materials requirements for CO₂ capture, compression, transport and storage. This extra operational costs due to CO₂ capture are partly compensated in the CCU and CCUS cases because CO₂ is utilised in the synthesis of DME and polyol and therefore this cases benefit from lower feedstock demand than in the REF and CCS, in which DME and polyol are manufactured via the conventional routes.

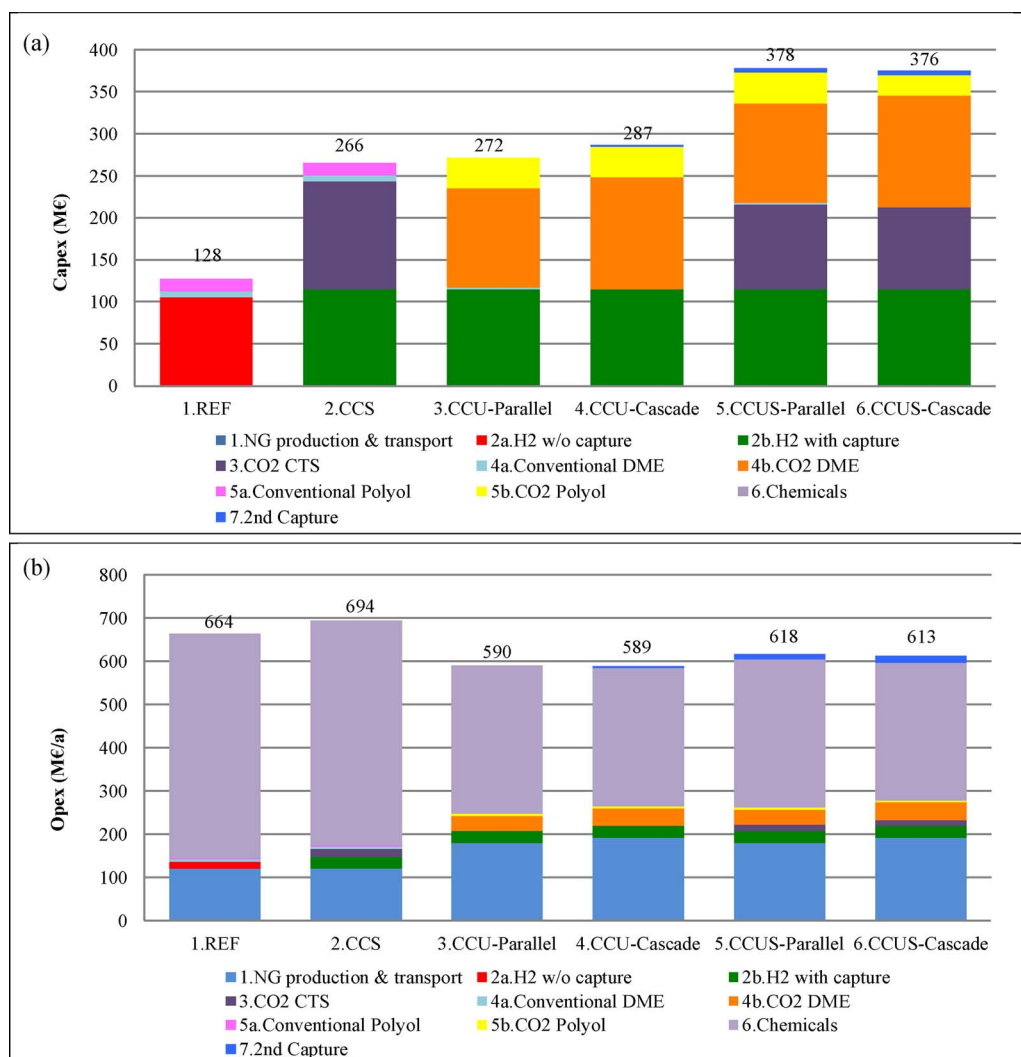

Fig. 5. (a) Capex per system area (M€), (b) Opex per system area (M€/a).

Total system costs follow the same trends as the Opex. Note that no CO₂ price (tax) was assumed in the estimation of the total costs at system level (H₂ unit + DME production + polyol production). From a refinery perspective, taking into account a CO₂ allowance price from the emissions trading system will further motivate the introduction CO₂ capture units.

The NPV analysis shows that in economic terms, the most preferable systems are the multi-product CCU configurations (cases 3 and 4), followed by the multi-product CCUS (cases 5 and 6). CCUS systems have higher total costs and lower NPV than the CCU cases because they include a second capture unit, CO₂ compression, transport and storage. Only the CCS system (case 2) shows higher total costs and lower NPV than the reference system (case 1) with no capture. This is an interesting finding since previous studies have shown that other CCU plants producing methanol or formic acid considering renewable H₂ from electrolysis, do not easily achieve a positive NPV [7,8,6].

• Capex contribution per system area

The differences in the Capex between the different cases are better understood by analysing the SA contribution, as depicted in Fig. 5a.

In all case studies the capital costs increase with respect to the REF case due to the incorporation of the first capture unit. However, the most capital-intensive system areas making a difference between the case studies are SA 3. CO₂ compression, transport and storage and SA 4b.

CO₂-DME synthesis, both of them due to compression costs. The Capital costs of SA 3. CO₂ CTS and SA 4b. CO₂-DME synthesis only differ by 9%. Therefore, the total Capex of the CCS-only system (case 2) and the CCU systems (cases 3 and 4) is rather similar because they include only one of these two system areas. However, the CCUS systems (cases 5 and 6) include both SA 3 and SA 4b. Consequently, the CCUS systems show the highest capital costs.

• Opex contribution per system area

Fig. 5b. shows that the Opex of SA 1. NG production and transport increases for the CCU and CCUS systems (cases 3 to 6) respect to the REF and CCS-only systems (cases 1 and 2). NG is used for the production of H₂, which is included in all systems investigated, but also in the synthesis of CO₂-DME, which is only included in the utilisation systems (cases 3 to 6).

SA 6. Chemicals has the highest share in the Opex of all cases. There are two major contributors to the Opex of SA 6. Chemicals i.e., methanol used as feedstock in the synthesis of conventional DME and PO used as feedstock in the manufacture of polyols. No methanol is needed in the cascade cases since all DME production is based on the CO₂ route. In the parallel cases, only a small amount of MeOH is needed for the production of conventional DME (46 kt/a MeOH to produce 33 kt/a conventional DME, Table 2, Section 2.1). 17% of the PO needed for conventional polyol production is replaced by CO₂ in the CCU and CCUS

Table 4
Product costs per case study (€/kg).

Case study	H ₂	DME	Polyol
1.REF	2.5	0.75	1.54
2.CCS	3.3	0.75	1.54
3.CCU-Parallel	2.5	0.74	1.32
4.CCU-Cascade	2.5	0.72	1.33
5.CCUS-Parallel	2.5	0.94	1.32
6.CCUS-Cascade	2.5	0.92	1.31

cases. Thus, compared to the REF and CCS cases, the Opex of SA 6. *Chemicals* for the parallel and cascade systems are reduced by 34% and 38%, respectively.

3.2.2. Final product costs

The production costs of H₂, DME and polyol were estimated per case study (Table 4). Note that different cost allocation factors were used in the case studies as explained in (Section 2.3.3). The allocation factors used are in the Supplementary material (S.2.4).

H₂ costs in the CCS case increase by 30% compared to the reference system because the capture costs are allocated to H₂ due to mitigation purposes. The CCU and CCUS cases are driven by utilisation goals, and therefore H₂ costs remain the same as in the reference case without capture.

The results indicate that even when including capture expenses, DME costs in the CCU cases are slightly lower than in the REF and CCS cases, indicating that conventional DME production is more expensive than CO₂-DME production. Although CO₂-DME has higher Capex due to compression costs, it has lower feedstock costs than conventional DME, which have a larger share in the total costs. In the CCUS systems all CO₂ emitted during CO₂-DME synthesis is captured and stored (case 5) or partly used and partly stored (case 6). Allocation of capture costs increase DME costs in the CCUS systems by 23–25% relative to the REF case.

The largest variation is found in the final product costs of polyols. CO₂-based polyol costs in the CCU and CCUS cases, are 14–15% lower than conventional polyol costs in the REF and CCS cases. This shows a clear business case for CO₂-polyol even when the cost of capture are allocated to the final product as in this study, which is mostly due to replacing part of the PO feedstock with CO₂.

3.3. Environmental assessment

Table 5 shows the climate change (CC) and fossil depletion (FD) impacts estimated per case study. A complete overview of life cycle inventories and elementary flows are reported in the Supplementary material (S.3.2).

Table 5
Environmental assessment results. CC: climate change; FD: fossil depletion, FU: functional unit.

	No utilisation		Multi-product CCU		Multi-product CCUS	
	1.REF	2.CCS- only	3. Parallel	4. Cascade	5. Parallel	6. Cascade
CC (kg C-O ₂ eq/FU)	0.294	0.255	0.260	0.261	0.239	0.241
FD (kg oil eq/FU)	0.140	0.144	0.127	0.127	0.131	0.131

• Climate change

Contrary to expectations, there is no significant difference among the storage and utilisation cases at system level. Upstream emissions are those related to all the industrial activities from the point of resource extraction to the process where it is used. Upstream emissions in this case correspond to SA 1. *NG production and transport* and SA 6. *Chemicals*. They have a significant share of the climate change potential in all systems, especially in the systems without utilisation. Fig. 6 shows the contribution of upstream and process emissions to the climate change indicator. Although the values at the system level are similar, significant differences are found between the different stages (upstream vs. factory gate). The results show that the displacement impacts (e.g., which fossil-based product is replaced) matters. PO is a very energy intensive chemical and thus, PO replacement in polyol synthesis results in large decrease in upstream emissions in all utilisation cases. Factory gate CO₂-DME climate change potential is higher than conventional DME due to compression requirements and direct emissions. Therefore, process-related emissions of the utilisation systems are larger than the CCS case.

At system level, upstream climate change reduction by PO replacement in CO₂-polyol synthesis is not enough to compensate the increase in climate change potential driven by CO₂-DME production, relative to the conventional DME route. Consequently, the utilisation-only systems (cases 3 and 4) show slightly higher climate change than the storage-only system (case 2). The systems that combine utilisation and storage (cases 5 and 6) show the largest potential for climate change mitigation, since in addition to PO replacement by CO₂ in polyol synthesis, CO₂ released in DME synthesis is re-captured and stored.

Finally, the results show no significant differences between the cascade and parallel configurations. The extra effort needed to recycle CO₂ in the cascade systems does not show a penalty nor a benefit.

• Fossil depletion

Upstream contributions (SA 1. *NG production and transport* and SA 6. *Chemicals*) determine the total fossil depletion in all systems investigated (Fig. 7). Natural gas is used as feedstock in CO₂-DME synthesis. Therefore, the fossil depletion contribution of SA 1 in all CCU and CCUS systems is higher than in the REF and CCS cases that include conventional DME production.

Lower methanol and PO feedstock requirements in the CCU and CCUS systems are the main cause for a smaller contribution of SA 6. *Chemicals*. Consequently, all CCU and CCUS cases have lower fossil depletion impact than the REF case. CCUS systems (cases 5 and 6) have a somewhat (3%) higher fossil depletion than the CCU systems (cases 3 and 4) because of the second capture unit.

The CCS system does not benefit from feedstock replacement and therefore it shows the highest fossil depletion among all systems.

4. Comparative assessment of multiproduct CCU and CCUS systems. Potential and limitations

The aim of this study was to examine the technical, economic and environmental feasibility of multi-product CCU and CCUS implementation and compare their performance with more conventional CCS alone. Each system presents trade-offs between technical, economic and environmental aspects, which highlights the importance of performing integrated assessments.

Table 6 summarises the outcomes of the comparative assessment, taking as a reference a H₂ unit at a refinery without carbon capture (case 1.REF). The arrows show whether the indicator increases or decreases with respect to the REF case. Multiple arrows emphasise the magnitude of the increase or reduction. Zero is given when the indicator value is equal to the reference.

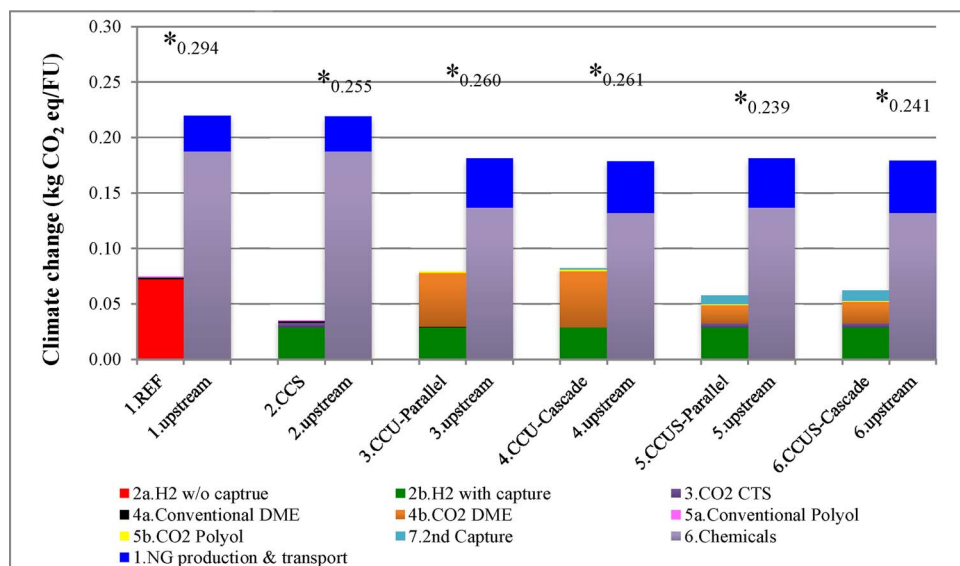

Fig. 6. Climate change per system area. Upstream and process contribution. * total system climate change.

• Carbon capture and storage. CCS-only system

Implementation of carbon capture and storage alone (case 2) is the best option to reduce direct CO₂ emissions in a refinery (−70% direct emissions relative to the REF case). However, compared to the reference case without carbon capture, CCS alone is not economically profitable (+7% total costs) neither environmentally advantageous in terms of fossil depletion.

• Multi-product CCU

Multi-product CCU systems (cases 3 and 4) show lower direct CO₂ emissions and climate change than the reference system (case 1) but higher than the storage-only system (case 2). The reason lies in the large emissions during CO₂-DME synthesis. Therefore, from a climate change mitigation perspective, it is preferable CO₂ storage than utilisation.

Multi-product CCU systems benefit from replacing fossil feedstock by CO₂. Multi-product CCU systems show the best economic and fossil depletion performance of all systems evaluated. The total costs of the

CCU systems are reduced by 9% and 15% with respect to the REF and CCS systems, respectively, and they have the highest NPV of all cases evaluated. In contrast, a positive NPV is not readily attained in other CCU options such as methanol or formic acid using renewable H₂ from electrolysis as feedstock [7,8,6]. The fossil depletion of the multi-product CCU cases is about 12% lower than the REF and CCS cases.

When assessing the parallel vs. cascade configuration, no differences are found in the total costs, climate change and fossil feedstock potential and very minor differences appear in the final product costs of polyol and DME.

• Multi-product CCUS

The lowest climate change potential is achieved in the CCUS systems because the CO₂ released in DME production is re-captured and stored (case 5) or partially used and partially stored (case 6). CCUS systems reduce climate change by 18% with respect to the REF case.

Although the total costs and fossil depletion of the CCUS systems is lower than the reference system with no carbon capture, larger energy and materials demand due to the second capture unit, CO₂ compression,

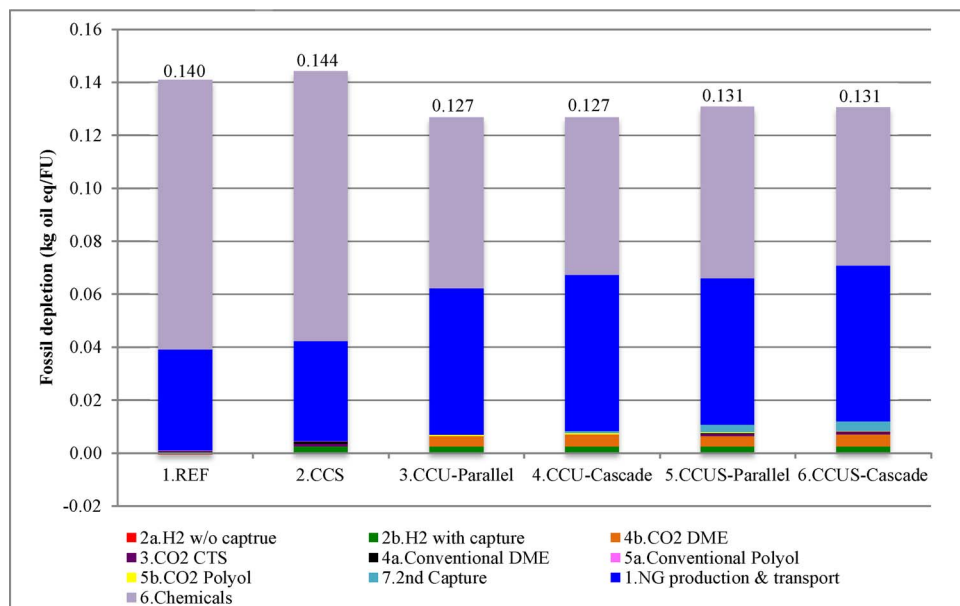

Fig. 7. Fossil depletion per system area.

Table 6

Techno-economic and environmental comparative assessment of CCU and CCUS alternatives relative to a reference case with no carbon capture.

Indicator	No utilisation	Multi-product CCU			Multi-product CCUS	
	2. CCS-only	3. Parallel	4. Cascade	5. Parallel	6. Cascade	
CO ₂ emissions	↓↓↓	↓	↓	↓↓	↓↓	
Fossil feedstock	0	↓	↓↓	↓	↓↓	
Total costs	↑	↓↓	↓↓	↓	↓	
NPV	↓↓	↑↑	↑↑	↑	↑	
H ₂ costs	↑↑	0	0	0	0	
DME costs	0	↓	↓↓	↑↑	↑	
Polyol costs	0	↓↓	↓	↓↓	↓↓↓	
Climate change	↓↓	↓	↓	↓↓↓	↓↓↓	
Fossil depletion	↑	↓↓	↓↓	↓	↓	

transport and storage increases the total system costs and fossil depletion of CCUS respect to the utilisation-only (CCU) systems.

Furthermore, CCUS systems show the highest DME production costs of all alternatives and the lowest polyol costs (+26% and –15% relative to REF). DME and polyol are produced based on CO₂ in the CCU and CCUS cases, but the allocation of the capture costs changes depending on whether it is stored or utilised.

5. Conclusions

The goal of this article was to explore the practicability of multi-product carbon capture and utilisation (CCU) and multi-product carbon capture, utilisation and storage (CCUS) concepts to aid closing carbon cycles in refineries.

To answer this research question, a case study including a hydrogen manufacturing unit with CO₂ capture and utilisation into dimethyl ether (DME) and polyols was defined. Two multi-product CCU and multi-product CCUS systems were evaluated in this research: simultaneous CO₂ utilisation in *parallel* configuration and 2-cycle CO₂ utilisation in *cascade* configuration. The techno-economic and environmental performance of these multi-product configurations were compared with a reference case without carbon capture and a case with carbon capture and storage-only (CCS, no CO₂ utilisation).

The integrated techno-economic and environmental assessments carried out in this study show that multi-product CCU and multi-product CCUS systems are cost-effective options that can contribute towards closing the carbon cycles in refineries. The CCU and CCUS parallel and cascade configurations show lower total system costs and environmental impacts than a reference case without carbon capture.

This explorative research points out the importance of performing holistic analysis of CCU and CCUS complex configurations including the CO₂ source, economic and environmental attributes: although the

largest direct CO₂ emission reductions are achieved with carbon capture and storage-only (CCS) without CO₂ utilisation, the economic evaluation shows that *CCS-only* is not an economically viable option. Feedstock replacement by CO₂ is the key to make CCU and CCUS configurations feasible options to reduce CO₂ emissions from the petrochemical sector while having an interesting business case.

The results show trade-offs between the economic and environmental performance in the CCU and CCUS systems. The CCUS systems present higher direct CO₂ emissions reductions than the CCU systems, and the lowest climate change potential among all systems studied. Nevertheless, compared to CCU systems, CCUS present a more limited economic potential and higher fossil depletion due to the incorporation of a second capture unit, CO₂ compression, transport and storage.

This approach also aimed to explore comparative advantages of different multi-product CO₂ utilisation (and CO₂ storage) configurations. The results however show no conclusive differences between the economic and environmental performances of the parallel and cascade configurations. The studied systems are rather complex, and differences at unit levels compensate each other at the system level, and therefore both configurations showed similar costs and environmental impacts.

This prospective study serves to identify cost-effective mitigation alternatives that should be further explored and considered in the research efforts for closing the carbon cycles in the petrochemical industry.

Acknowledgments

This project was carried out as part of the EDDiCCUT project (www.eddiccut.com). EDDiCCUT is a 4-year research project (2012–2016) supported by the Norwegian Research Council under grant number 218952 and by an industrial consortium (Bharat Petroleum, Uniper, and Norske Shell).

Appendix A. Economic evaluation

The raw materials prices were taken from different sources and updated to €₂₀₁₆. The values used in the economic evaluation are in [Table A1](#). The product purchase prices assumed for the estimation of the net present value (NPV) are shown in [Table A2](#).

Table A1
Raw material prices.

Material	Acronym	Cost [€ ₂₀₁₆ /kg]	Source
Methanol	Methanol	0.51	[42]
Propylene oxide	PO	1.50	[43–47] ^a
Glycerol	G	0.75	[48]
Monopropylene glycol	MPG	1.65	Proxy, 150 €/tonne higher than PO

^a Average of these values. See Supplementary material for additional details (S.2.2).

Table A2
Product purchase prices.

Product	Price (€ ₂₀₁₆ /kg)	Source
H ₂	3.14	[49]
DME	1.29	[50,51]
Polyol	1.70	[52]

Appendix B. Life Cycle Assessment Assumptions

The assumptions taken during the life cycle inventory assessment (LCIA) were:

- Natural gas production and imports are those of the Netherlands, adopted from the Eurogas report [53].
- Share of onshore/offshore gas production in the Netherlands adopted from [54].
- Given the absence of data and considering that the gas fields for the Netherlands are also located in the North Sea as the Norwegian ones, the LCI for offshore transport in Norway was used for transport of Dutch gas as well.
- The lengths of NG pipelines adopted, assuming that the plant is located in the Rotterdam area, are shown in Table B1.
- CO₂ transport and storage infrastructure was modelled by adopting the NG pipeline and well infrastructure in the Ecoinvent database. It was assumed that CO₂ is stored offshore in one well of 1000 m depth. The length of the transport pipeline was assumed to be 100 km in total, 5 km onshore to the port and 95 km offshore to the saline aquifer.
- The transport of chemicals to plant was modelled according to the model split of inland transport modes of freight transport in the EU-28 given by [56], see Table B2.
- For chemicals the ‘transport to disposal’ and ‘disposal phases’ are included in the SA that utilizes the chemicals. The impacts of ‘production of chemicals’ and ‘transport to plant’ are included in SA 6. Chemicals. The mode and transport distances are adopted from The Ecoinvent Report No.1 [57] where the transport mode is road transport (lorry), the distance for residual material landfill is 15 km, and distance for residual material landfill is 50 km. Due to absence of separate datasets for waste disposal of the chemicals it was assumed that all waste, except zeolite, goes to residual material landfills, where inorganic, industrial waste is deposited [58]. Zeolite disposal is modelled to inert material landfills.
- The amount of CO₂ fugitive emissions during CO₂ transport to storage adopted is 0.01% of transported CO₂ [41].
- The amount of CH₄ fugitive emissions is in the range of 0.2% to 6% of the natural gas produced [41]. In this study, an average of the range (3.1%) was assumed for CH₄ fugitive emissions. Fugitive emissions associated with unconventional shale gas are on average higher than the ones associated with conventional natural gas. Conventional natural gas is utilised in this work. Therefore, the value assumed sets a conservative approach since values lower than 3.1% are found in the literature for CH₄ fugitive emissions from shale gas production and transport [59]. The impacts of CH₄ fugitive emissions (FEI) were calculated using ReCiPe characterization factors [60] following Eq. (B1).

$$CH_4FEI_{I,C,x} \left[\frac{Unit_{I,C,x}}{FU} \right] = 3.1\% * NG_{used} \left[\frac{kgCH_4}{FU} \right] * Car. Fact. \left[\frac{Unit_{I,C,x}}{kgCH_4} \right] \quad (B1)$$

The impact categories affected by CH₄ fugitive emissions are CC, POF and FD.

- The electricity mix is that of the Netherlands.
- Due to absence of data for treatment of wastewater as an effluent of the processes in question, the impacts of wastewater are assumed to be those of wastewater as an effluent of soft fireboard production. This process was chosen as it has the median impacts out of a group of class 3, industrial wastewater treatment processes in the Ecoinvent database.
- Two components were taken into account for calculating the impact of chilled water: industrial process water and the heat energy (MJ) required for lowering the temperature of water from room temperature (~20 °C) to 10 °C.

Table B1
Lengths of NG pipelines.

From	To	Name	Length (km)	Source
Netherlands	Netherlands	Nordgas transport	57	PE Cartographic, Statoil, 2016
Norway	Netherlands	Nordpipe	440	PE Cartographic, Statoil, 2016
Groningen	Rotterdam		245.18	TU [55]

Table B2
Percentage share of transport mode of freight transport in the EU-28.

Mode	Share [%]
Road	74.9
Rail	18.2
Inland waterways	6.9

- Due to absence of data, the impacts of MDEA production are modelled as those of MEA production since LCA data for MEA is regarded as proxy for amine-based solvents [26]. In addition, even though the solvent of the H₂ capture unit is a mixture of MDEA and PZ, only the impacts of MDEA are modelled because the ratio of MDEA/PZ is 9/1 [21].
- For $\gamma/\text{Al}_2\text{O}_3$ the impact of Al₂O₃ was adopted because it is a different phase of Al₂O₃ and they are both used as catalysts [61].
- Due to absence of data, the impacts of DMC are modelled as a combination of impacts of the catalyst components: sodium cyanide, Zn and Co. Sodium cyanide was chosen as a conservative assumption as it has the highest impacts of the cyanides in the Ecoinvent database.

Appendix A. Supplementary data

Supplementary data associated with this article can be found, in the online version, at <https://doi.org/10.1016/j.jcou.2017.11.008>.

References

- [1] Styring, P., Jansen, D., de Coninck, H., Reith, H., Armstrong, K., 2011. Carbon Capture and Utilisation in the Green Economy. Using CO₂ to manufacture fuel, chemicals and materials. Centre for Low Carbon Futures, 2011 and CO₂Chem Publishing 2012.
- [2] N. von der Assen, P. Voll, M. Peters, A. Bardow, Life cycle assessment of CO₂ capture and utilization: a tutorial review, *The R. Soc. of Chem.* (2014) 7982–7994.
- [3] E.A. Quadrelli, G. Centi, J.L. Duplan, S. Perathoner, Carbon dioxide recycling: emerging large-scale technologies with industrial potential, *ChemSusChem* 4 (9) (2011) 1194–1215, <http://dx.doi.org/10.1002/cssc.201100473>.
- [4] SCOT, Smart CO₂ Transformation, (2017) Retrieved from <http://www.scotproject.org/>.
- [5] I. Dimitriou, P. García-Gutiérrez, R.H. Elder, R.M. Cuéllar-Franca, A. Azapagic, R.W.K. Allen, Carbon dioxide utilisation for production of transport fuels: process and economic analysis, *Energy Environ. Sci.* 8 (2015) 1775, <http://dx.doi.org/10.1039/c4ee04117h>.
- [6] D. Bellotti, M. Rivarolo, L. Magistri, A.F. Massardo, Feasibility study of methanol production plant from hydrogen and captured carbon dioxide, *J. CO₂ Util.* 2 (2017) 132–138, <http://dx.doi.org/10.1016/j.jcou.2017.07.001>.
- [7] M. Pérez-Portes, J. Schöneberger, A. Boulamanti, E. Tzimas, Methanol synthesis using captured CO₂ as raw material: techno-economic and environmental assessment, *Appl. Energy*. 161 (2016) 718–732, <http://dx.doi.org/10.1016/j.apenergy.2015.07.067>.
- [8] M. Pérez-Portes, J.C. Schöneberger, A. Boulamanti, G. Harrison, E. Tzimas, Formic acid synthesis using CO₂ as raw material: techno-economic and environmental evaluation and market potential, *Int. J. Hydrogen Energy* 41 (37) (2016) 16444–16462, <http://dx.doi.org/10.1016/j.ijhydene.2016.05.199>.
- [9] IEA and UNIDO, Technology Roadmap: Carbon Capture and Storage in Industrial Applications, (2011).
- [10] G. Centi, S. Perathoner, Opportunities and prospects in the chemical recycling of carbon dioxide to fuels, *Catal. Today* 148 (3–4) (2009) 191–205, <http://dx.doi.org/10.1016/j.cattod.2009.07.075>.
- [11] V.M. Lebarbier, R.A. Dagle, L. Kovarik, J.A. Lizarazo-Adarme, D.L. King, D.R. Palo, Synthesis of methanol and dimethyl ether from syngas over Pd/ZnO/Al₂O₃ catalysts, *Catal. Sci. Technol.* 2 (10) (2012) 2116, <http://dx.doi.org/10.1039/c2cy20315d>.
- [12] G.A. Olah, A. Goepfert, G.K.S. Prakash, Chemical recycling of carbon dioxide to methanol and dimethyl ether: from greenhouse gas to renewable, environmentally carbon neutral fuels and synthetic hydrocarbons, *J. Org. Chem.* 74 (2) (2009) 487–498, <http://dx.doi.org/10.1021/jo801260f>.
- [13] Nykomb Synergetics, 2008. Retrieved from <https://web.archive.org/web/20080603115705/http://www.nykomb.se/index.php?s=Chemicals>.
- [14] Z. Azizi, M. Rezaeiimesh, T. Tohidian, M.R. Rahimpour, Dimethyl ether: a review of technologies and production challenges, *Chem. Eng. Process: Process Intensif.* 82 (2014) 150–172, <http://dx.doi.org/10.1016/j.cep.2014.06.007>.
- [15] P. Gangadharan, K. Kanchi, H. Lou, Evaluation of the economic and environmental impact of combining dry reforming with steam reforming of methane, *Chem. Eng. Res. and Des.* (2006) 1956–1968.
- [16] Bio-based news, 2016. <http://news.bio-based.eu/premiere-for-new-raw-material-covestro-launches-industrial-production-of-plastics-using-carbon-dioxide/>.
- [17] Plastics news, 2016. <http://www.plasticsnews.com/article/20160617/NEWS/306189999/covestro-opens-co2-to-polycarbonate-polyol-plant>.
- [18] A. Prokofyeva, C. Gürtler, CO₂ as building block for the chemical industry, United Nations Climate Change Conference, Bonn, Germany, 2014 https://unfccc.int/files/bodies/awg/application/pdf/04_bayer_angelina_prokofyeva.pdf.
- [19] W. Schakel, G. Oreggioni, B. Singh, A.H. Strømman, C.A. Ramírez, Assessing the techno-environmental performance of CO₂ utilization via dry reforming of methane for the production of dimethyl ether, *J. CO₂ Util.* 16 (2016) 138–149, <http://dx.doi.org/10.1016/j.jcou.2016.06.005>.
- [20] Ullmann, Ullmann's encyclopedia of industrial chemistry, *Hydrogen Section* §4.1.3.3 Steam Reforming Plant, John Wiley and Sons, Inc, 2007.
- [21] J.C. Meerman, E.S. Hamburg, T. van Keulen, A. Ramírez, W.C. Turkenburg, A.P.C. Faaij, Techno-economic assessment of CO₂ capture at steam methane reforming facilities using commercially available technology, *Int. J. Greenh. Gas Control* 9 (2012) 160–171, <http://dx.doi.org/10.1016/j.ijggc.2012.02.018>.
- [22] C. Fernández-Dacosta, M. van der Spek, C. Hung, G.D. Oreggioni, R. Skagestad, P. Parihar, D.T. Gokar, A.H. Strømman, A. Ramírez, Prospective techno-economic and environmental assessment of carbon capture at a refinery and utilisation in polyol synthesis, *J. CO₂ Util.* 21C (2017) 405–422.
- [23] M. van der Spek, A. Ramírez, A. Faaij, Improving uncertainty evaluation of process models by using pedigree analysis: a case study on CO₂ capture with monoethanolamine, *Comp. Chem. Eng.* 85 (2016) 1–15.
- [24] D.J. Darensbourg, S.J. Wilson, What's new with CO₂? Recent advances in its copolymerization with oxiranes, *Green Chem.* 14 (2012) 2665–2671, <http://dx.doi.org/10.1039/c2gc35928f>.
- [25] J. Langanke, A. Wolf, J. Hofmann, K. Böhm, M.A. Subhani, T.E. Müller, W. Leitner, C. Gürtler, Carbon dioxide (CO₂) as sustainable feedstock for polyurethane production, *Green Chem.* 16 (2014) 1865–1870, <http://dx.doi.org/10.1039/C3GC41788C>.
- [26] N. von der Assen, A. Bardow, Life cycle assessment of polyols for polyurethane production using CO₂ as feedstock- insights from an industrial case study, *Green Chem.* (2014) 3272–3280.
- [27] Haider, K.W., McDaniel, K.G., Hayes, J.E., Shen, J., 2008. Polyether carbonate polyols made via double metal cyanide (DMC) catalysis. WO 2008013731 A1.
- [28] J. Hofmann, C. Gürtler, S. Grasser, A. Wolf, Process for the Production of Polyether Carbonate Polyols, (2014) US2014/0256908A1.
- [29] T.E. Müller, C. Gürtler, M.A. Subhani, Method for Producing Polyether Carbonate Polyols, (2014) US 20140323670 A1.
- [30] European Central Bank, Euro Exchange Rates USD. Average Data for January–April 2016, (2016) <https://www.ecb.europa.eu/stats/exchange/eurofxref/html/eurofxref-graph-usd.en.html>.
- [31] R. Sinott, Chemical engineering design, 4th ed., Coulson and Richardson's Chemical Engineering 6 Elsevier Oxford, 2005.
- [32] R. Towler, G. Sinott, Chemical Engineering Design: Principles, Practice and Economics of Plant and Process Design, Elsevier, 2008.
- [33] G.D. Ulrich, P.T. Vasudevan, How to estimate utility costs, *Chem. Eng.* 4 (2006) 66–69.
- [34] Eurostat, Gas Prices by Type of User, (2016) Retrieved from <http://ec.europa.eu/eurostat/tgm/refreshTableAction.do?tab=table&plugin=1&pcode=ten00118&language=en>.
- [35] IEA, Production Costs of Alternative Transportation Fuels: Influence of Crude Oil Price and Technology Maturity, (2013).
- [36] IEA, Resources to Reserves: Oil, Gas and Coal Technologies for the Energy Markets of the Future, (2013).
- [37] ZEP, The Costs of CO₂ Transport: Post-demonstration CCS in the EU, (2011).
- [38] ZEP, The Costs of CO₂ Storage: Post-demonstration CCS in the EU Zero Emissions Platform, IEAGHG. (2011).
- [39] ZEP, The Costs of CO₂ Capture, Transport and Storage: Post Demonstration CCS in the EU, (2011).
- [40] Goedkoop, M., Heijungs, R., Huijbregts, M., De Schryver, A., Struijs, J., van Zelm, R., 2013. ReCiPe 2008. A life cycle impact assessment method which comprises harmonised category indicators at the midpoint and the endpoint level.
- [41] E.A. Bouman, A. Ramírez, E. Hertwich, Multiregional environmental comparison of fossil fuel power generation—Assessment of the contribution of fugitive emissions from conventional and unconventional fossil resources, *Int. J. Greenh. Gas Control* (2015) 1–9.
- [42] ICIS, 2008. Independent Chemical Information Services. Retrieved from Indicative Chemical Prices A-Z: <http://www.icis.com/chemicals/channel-info-chemicals-a-z/>.
- [43] ICIS, 2006. <https://www.icis.com/resources/news/2006/09/15/2016152/chemical-profile-propylene-oxide/>.
- [44] ICIS, 2009. <https://www.icis.com/resources/news/2009/09/07/9245022/chemical-profile-propylene-oxide/>.
- [45] ICIS, 2011. <https://www.icis.com/resources/news/2011/11/21/9509807/chemical-profile-propylene-oxide/>.
- [46] ICIS, 2013. <https://www.icis.com/resources/news/2013/04/13/9658385/chemical-profile-europe-ethylene-oxide/>.
- [47] ICIS, 2015. Propylene Oxide: Miscellaneous, FD NEW Contract Price Assessment from 30 to 10-2005 to 30-10-2015. Data file. Retrieved from ICIS Dashboard on 04-11-2015.
- [48] E.L. Scott, M.E. Bruins, J.P.M. Sanders, Rules for the Bio-based Production of Bulk Chemicals on a Small Scale. Biobased Commodity Chem, Wageningen UR, the Netherlands, 2013 www.vpp.wur.nl/UK/.
- [49] C.E. Thomas, Hydrogen Cost Estimates via Steam Methane Reforming, (2009) (Retrieved from), http://www.cleancaroptions.com/Hydrogen_costs_per_mile.pdf.
- [50] IDA, 2015. International DME Association. Retrieved from <https://www.aboutdme.org/index.asp?bid=234#Q9>.
- [51] myLPG.eu, 2017. <https://www.mylpg.eu/stations/netherlands/prices>.
- [52] L. Shen, J. Haufe, M.K. Patel, Product Overview and Market Projection of Emerging

Bio-based Plastics. Final Report PRO-BIP 2009, Group Science, Technology and Society, Utrecht, the Netherlands, 2009.

- [53] Eurogas, (2013). Statistical Report.
- [54] IEA, Energy Supply Security: Emergency Response of IEA Countries, (2014).
- [55] TU Delft, 2016, enipedia.tudelft: http://enipedia.tudelft.nl/wiki/Groningen_-_Rotterdam_Pipeline.
- [56] Eurostat, 2016, May 17. Freight transport in the EU-28 modal split of inland transport modes. Retrieved from Eurostat Statistics explained: http://ec.europa.eu/eurostat/statistics-explained/index.php/File:Figure_1_Freight_transport_in_the_EU-28_modal_split_of_inland_transport_modes.png.
- [57] R. Frischknecht, N. Jungbluth, H. Althaus, G. Doka, R. Dones, T. Heck, G. Wernet, Ecoinvent Report No.1: Overview and Methodology, Swiss Centre of Life Cycle Inventories, Dübendorf, 2007.
- [58] G. Doka, Life Cycle Inventories of Waste Treatment Services. Ecoinvent Report No. 13, Swiss Centre for Life Cycle Inventories, Dübendorf, 2003.
- [59] A. Burnham, J. Han, C.E. Clark, M. Wang, J.B. Dunn, I. Palou-Rivera, Life-Cycle greenhouse gas emissions of shale gas, natural gas, coal, and petroleum, *Env. Sci. Technol.* (2012) 619–627.
- [60] ReCiPe. 2014, December ReCiPe Characterisation Version 1.11. Retrieved from ReCiPe Characterisation: <http://www.lcia-recipe.net/characterisation-and-normalisation-factors>.
- [61] M. Trueba, S. Trasatti, γ -Alumina as a support for catalysts: a review of fundamental aspects, *Eur. J of Inorg. Chem.* (2005) 3393–3403.



Cora Fernández-Dacosta is a researcher at the Copernicus Institute of Sustainable Development at Utrecht University, the Netherlands. Her research focuses in the design, techno-economic and environmental assessment of processes to convert waste streams into products. She is a Chemical Engineer with a Professional Doctorate in Engineering, Process and Equipment design from Delft University of Technology.



Viktorija Stojcheva is a Sustainable Industries and Services Consultant at Ecofys. Her work focuses on impact assessments, value chain carbon foot-printing of multinational companies, estimating projected emissions and emission intensity reductions in line with climate science and science based emission reduction target setting for companies. She has a joint bachelor degree in Physics and Environmental Science and a master's degree in Energy Science.



Andrea Ramírez is full professor of Low Carbon Systems and Technologies at Delft University of Technology and associate professor at the Copernicus Institute, Utrecht University. Her research aims at developing methodologies and tools that build bridges between fundamental research at laboratory scale and the insights needed by stakeholders on potential benefits and impacts of these technologies when implemented. Her research portfolio includes projects that assess the sustainability of novel bio-based materials and chemicals, and novel CO₂ capture and utilisation technologies.