

Making a[nd] Living

Crafting resilient neighbourhoods through urban manufacturing



CONCEPT

Concept volume

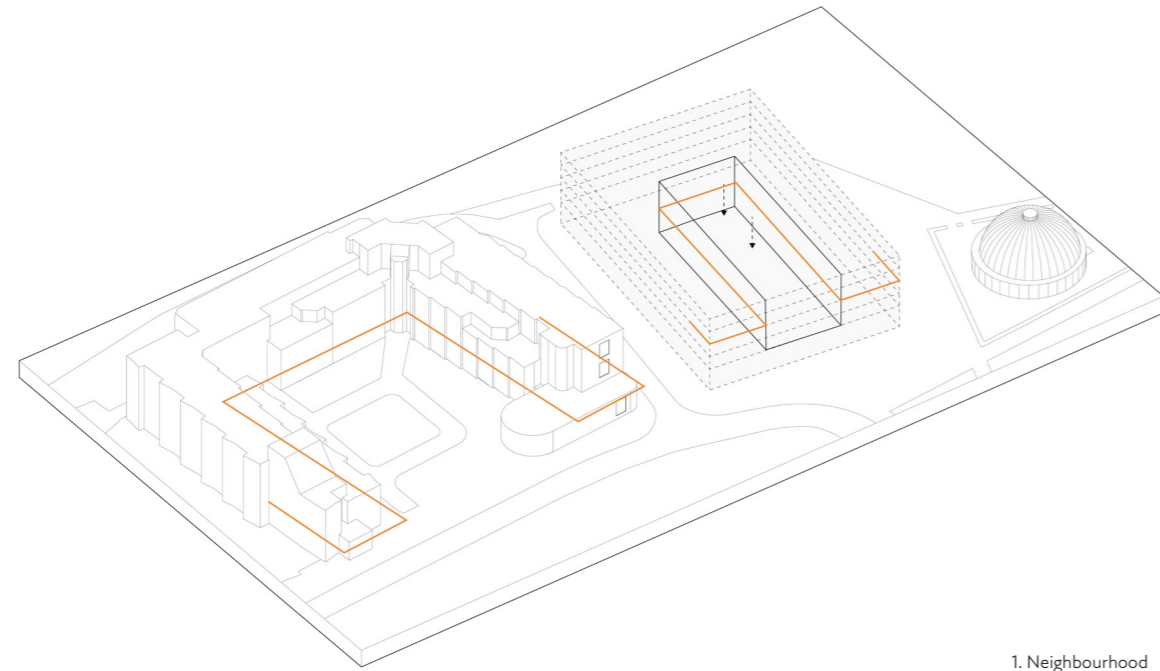

1. Neighbourhood

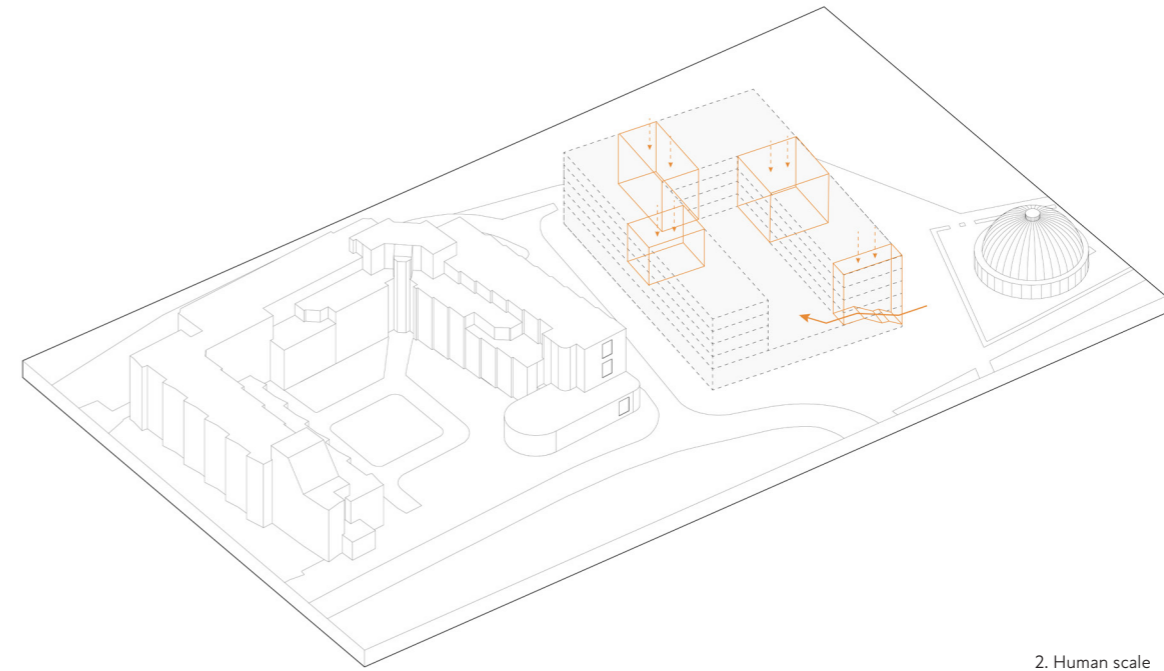

2. Human scale

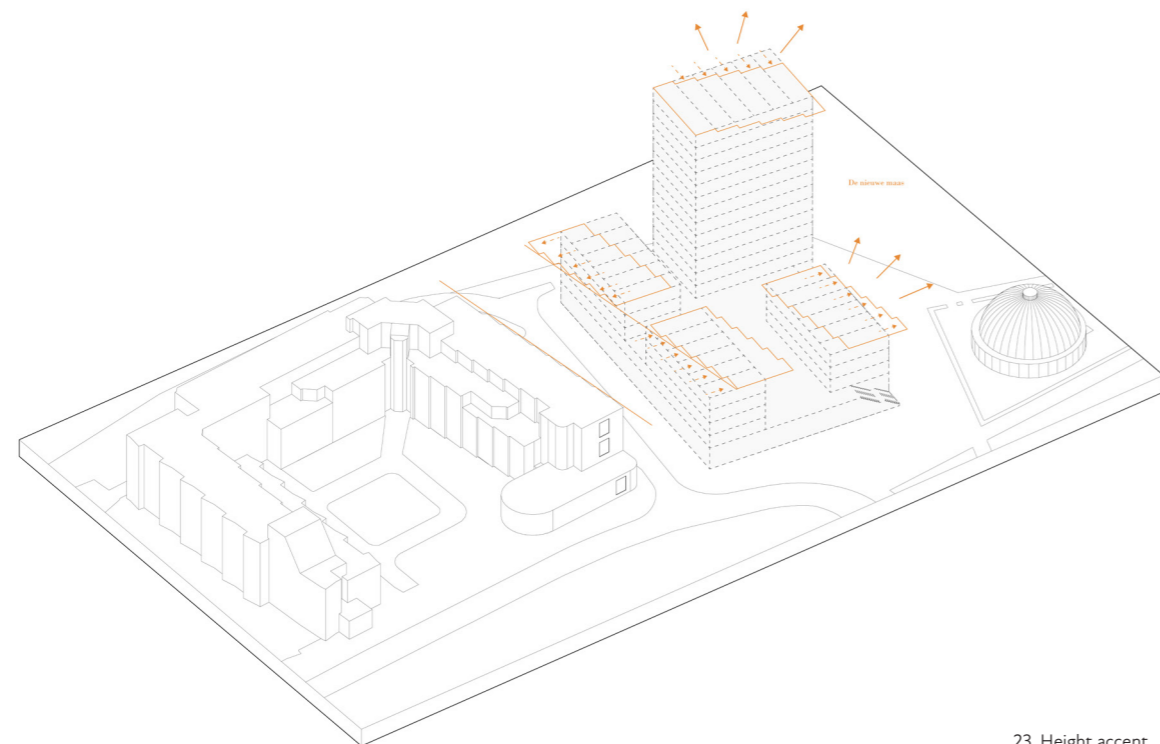

23. Height accent

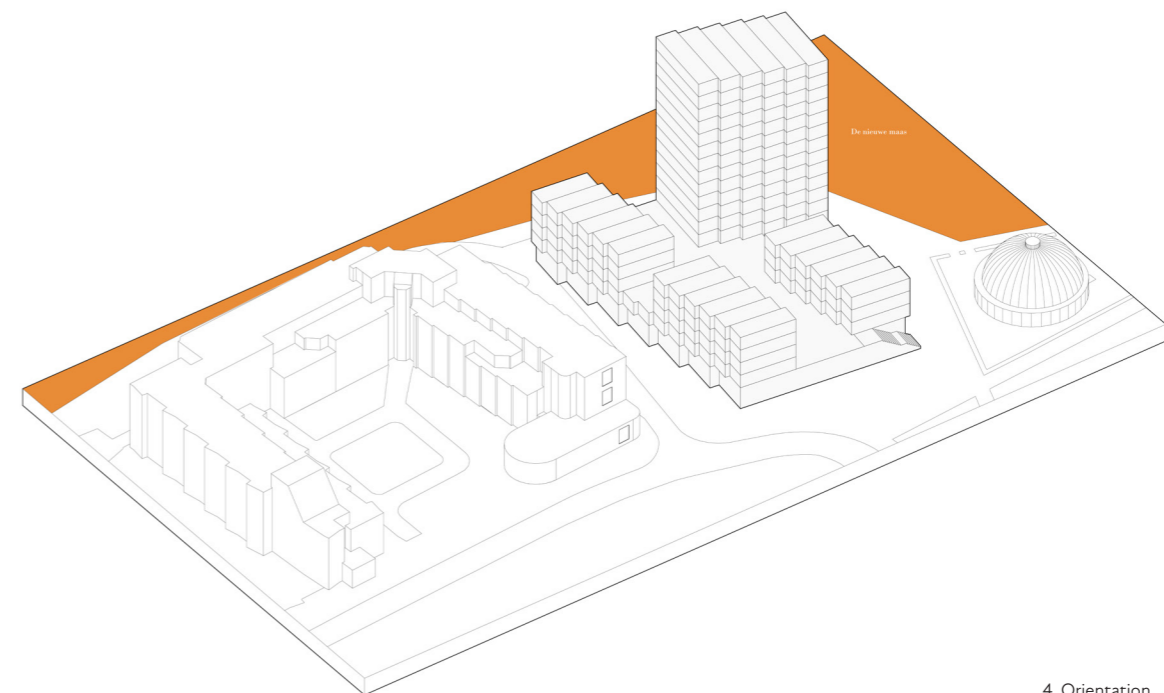

4. Orientation

Concept axonometric

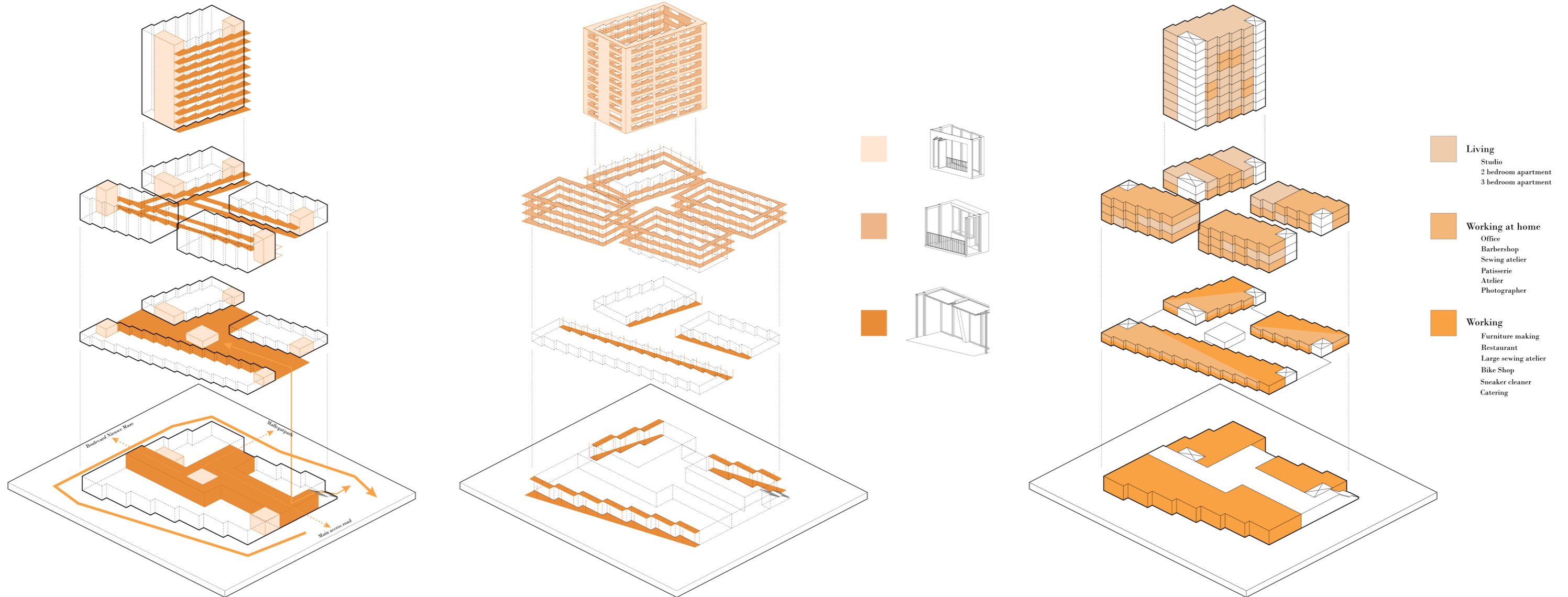

Concept live/work typology

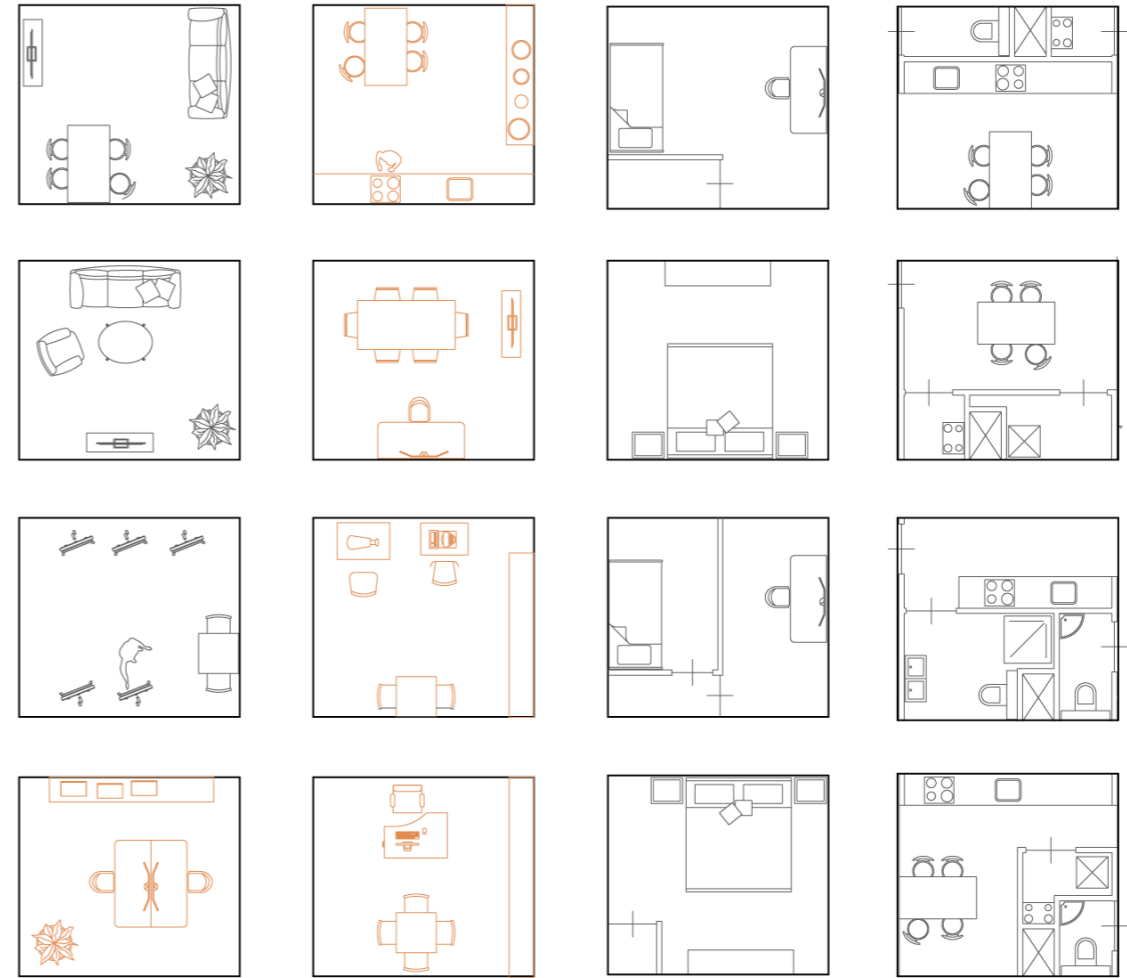
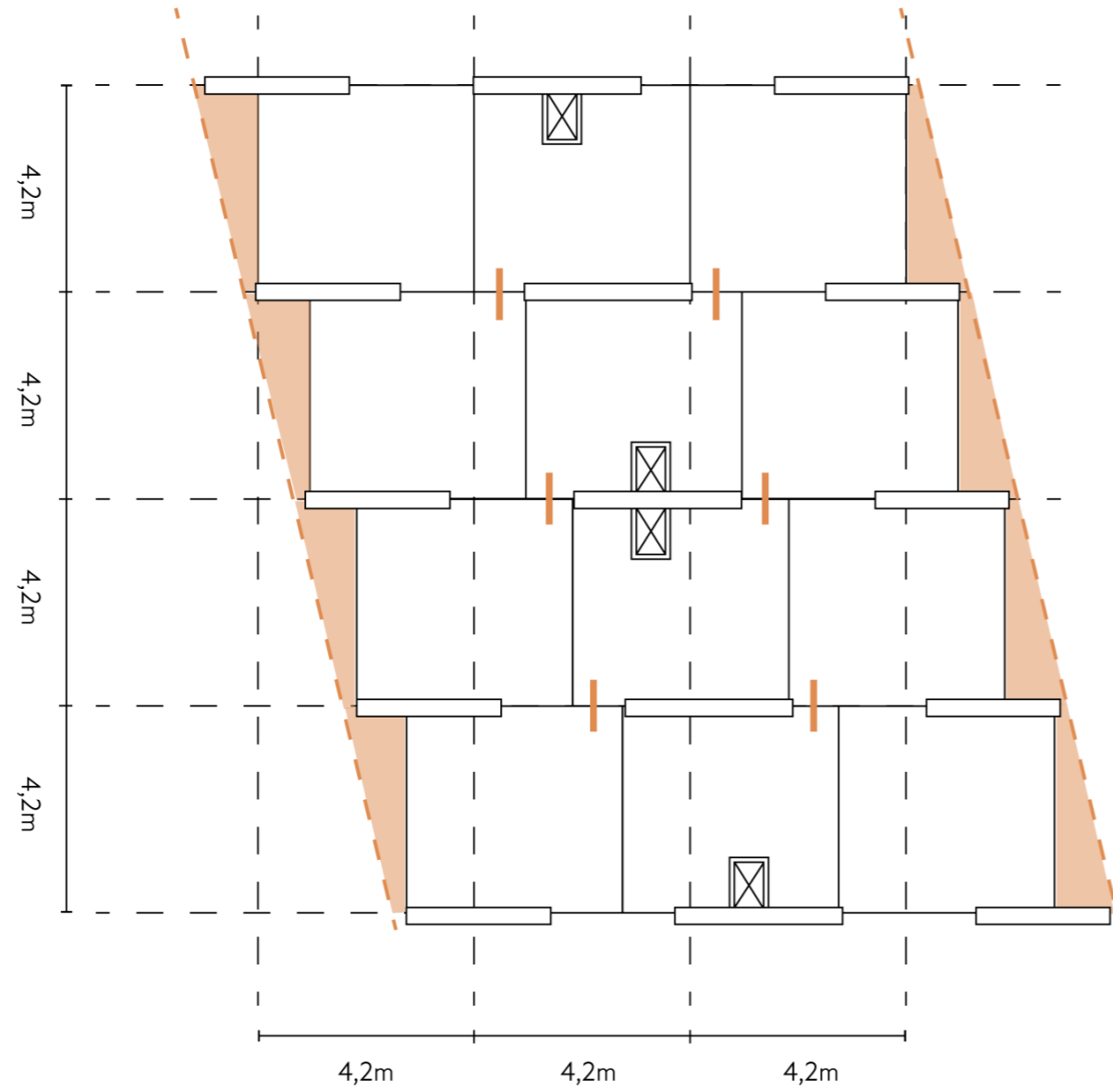

FLOORPLANS

Site plan

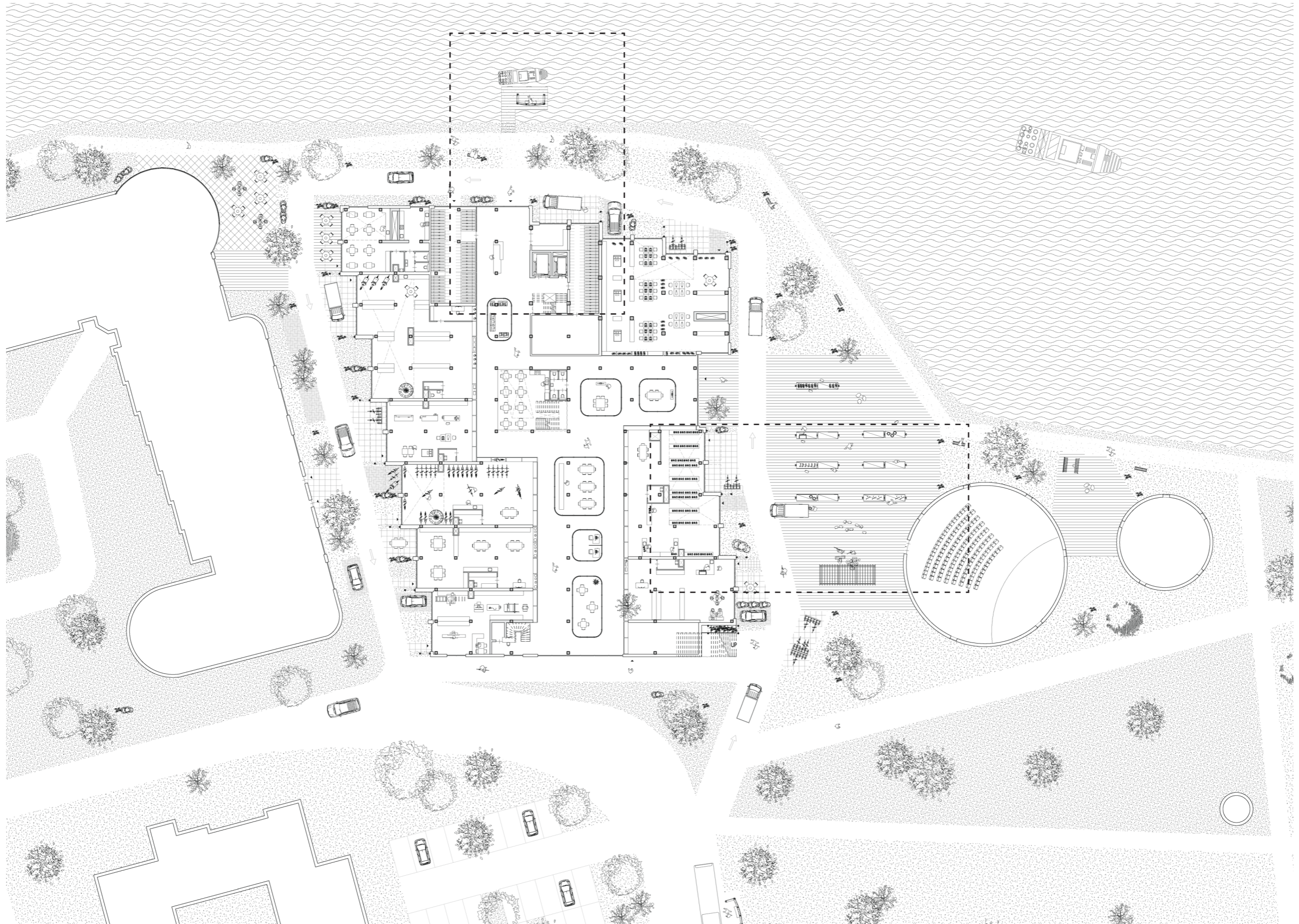

Site plan

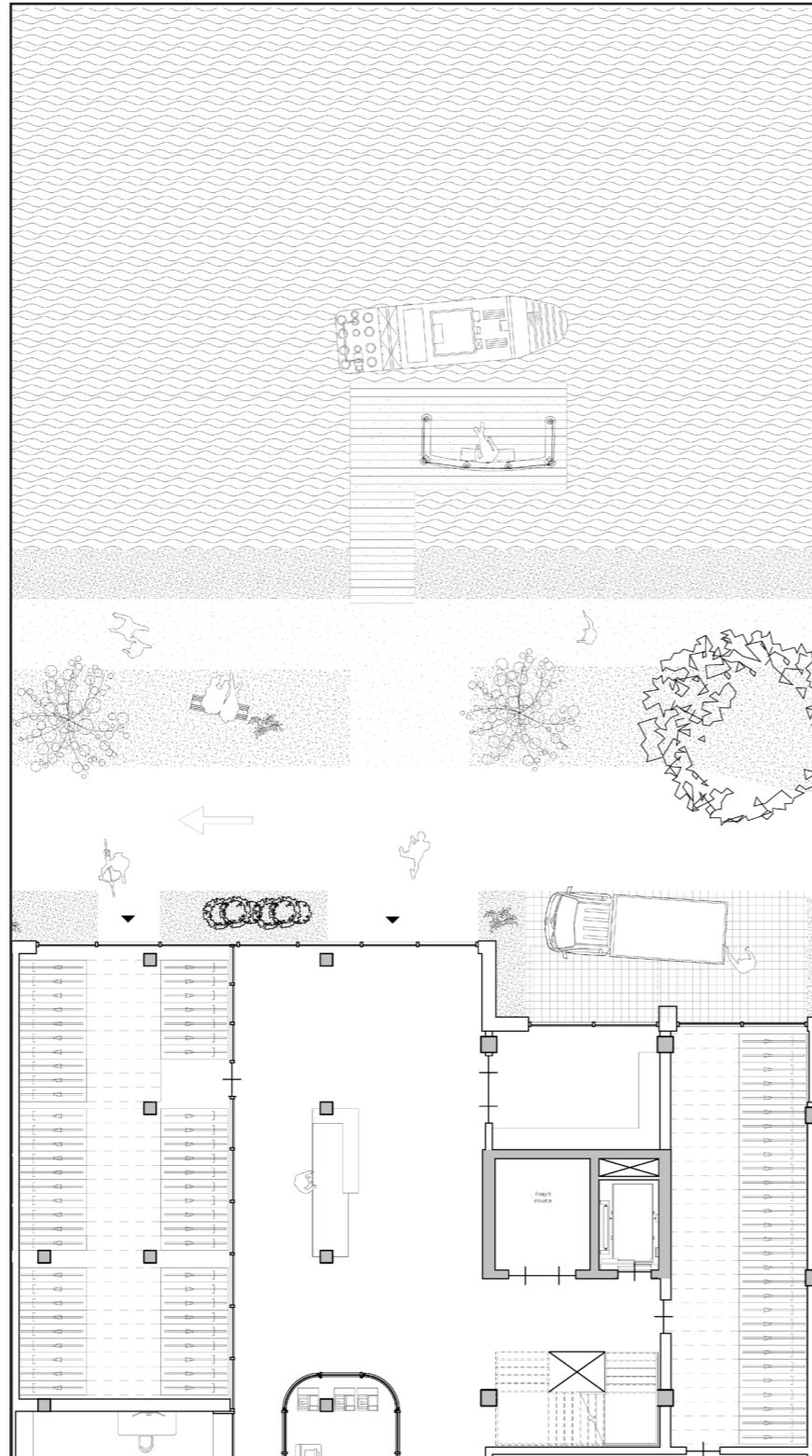

Boulevard 1:200

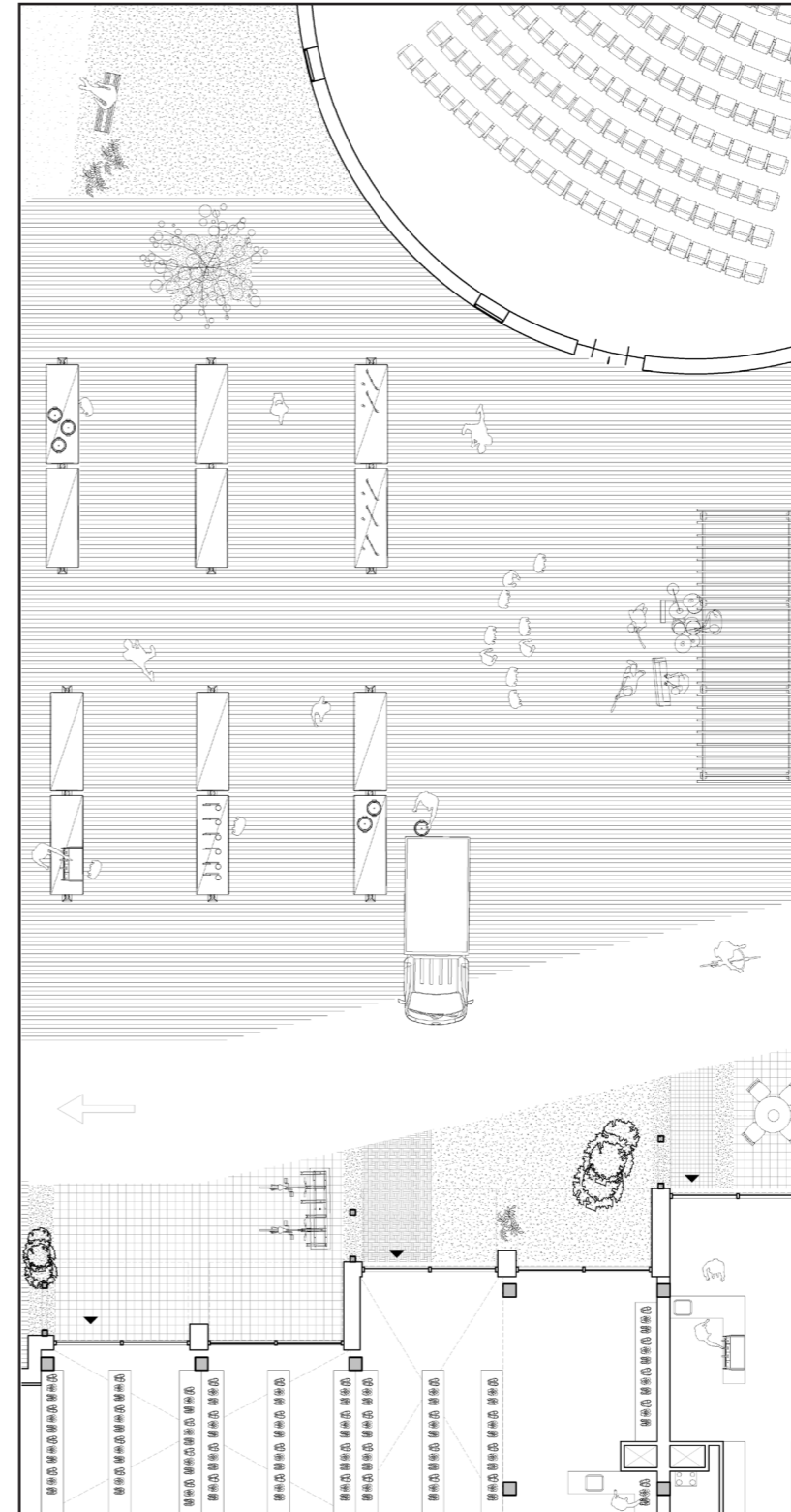

Malletgatpark 1:200

Ground level

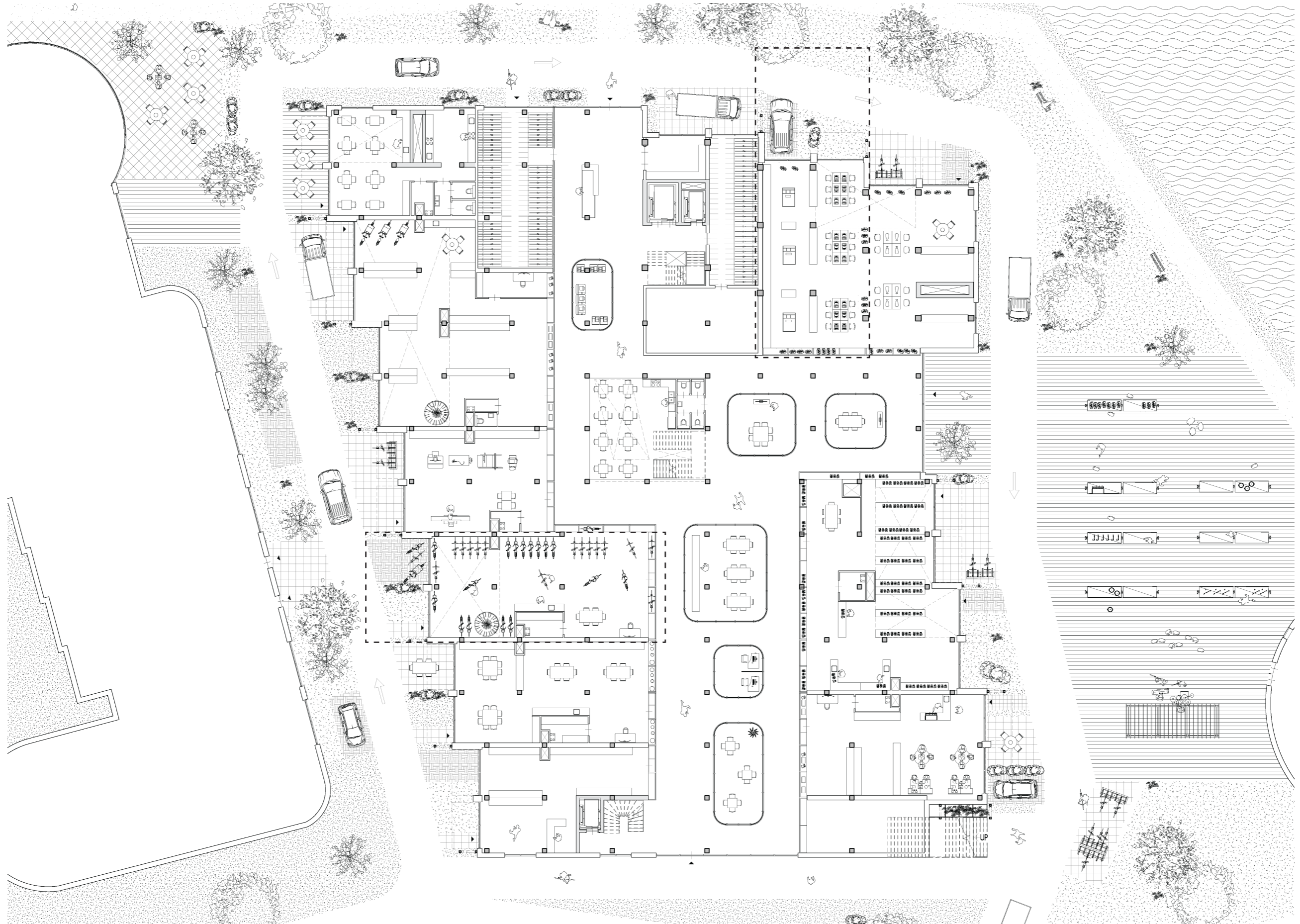

Ground level

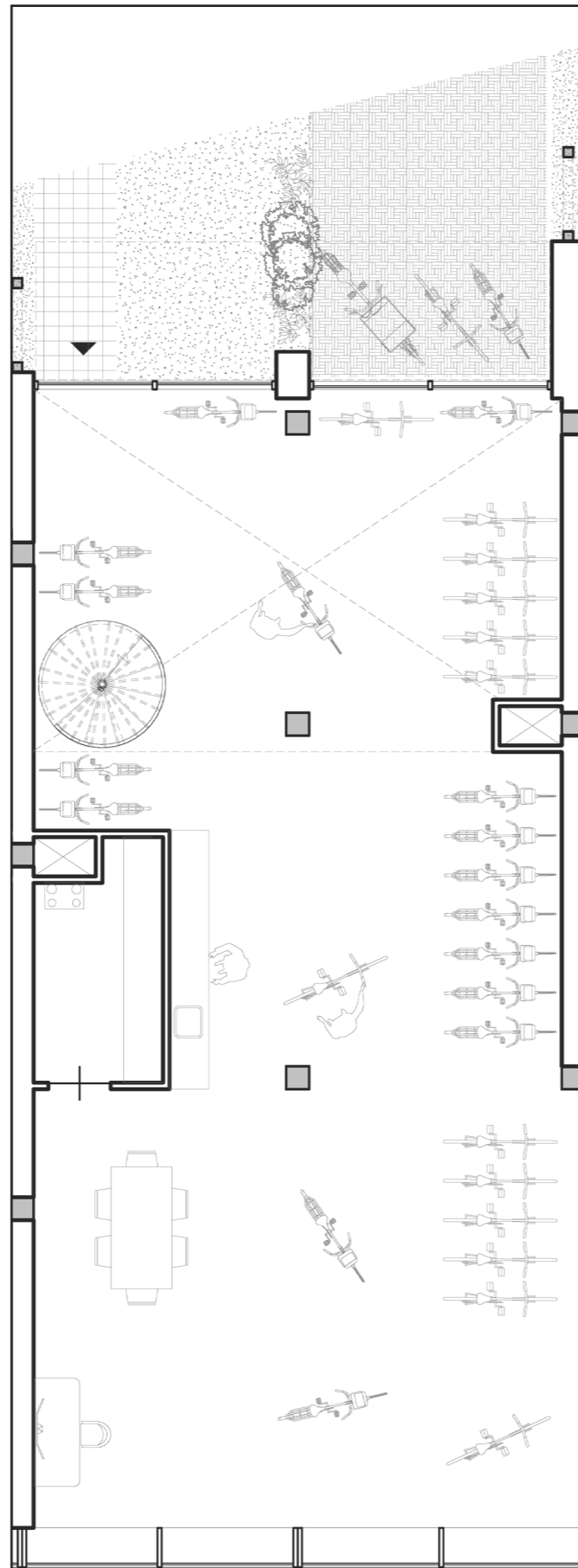

NouJIJ! - bike shop 1:100

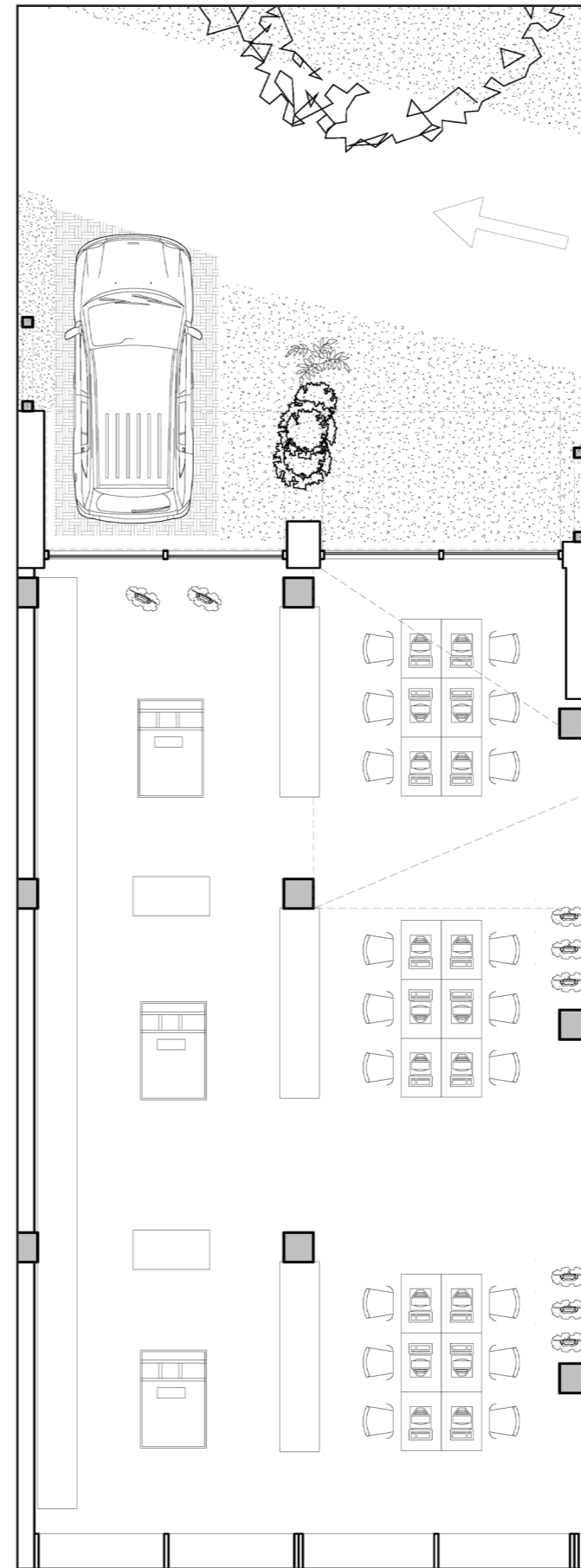

Oxious Talent Factory - sewing atelier 1:100

1st floor



1st floor

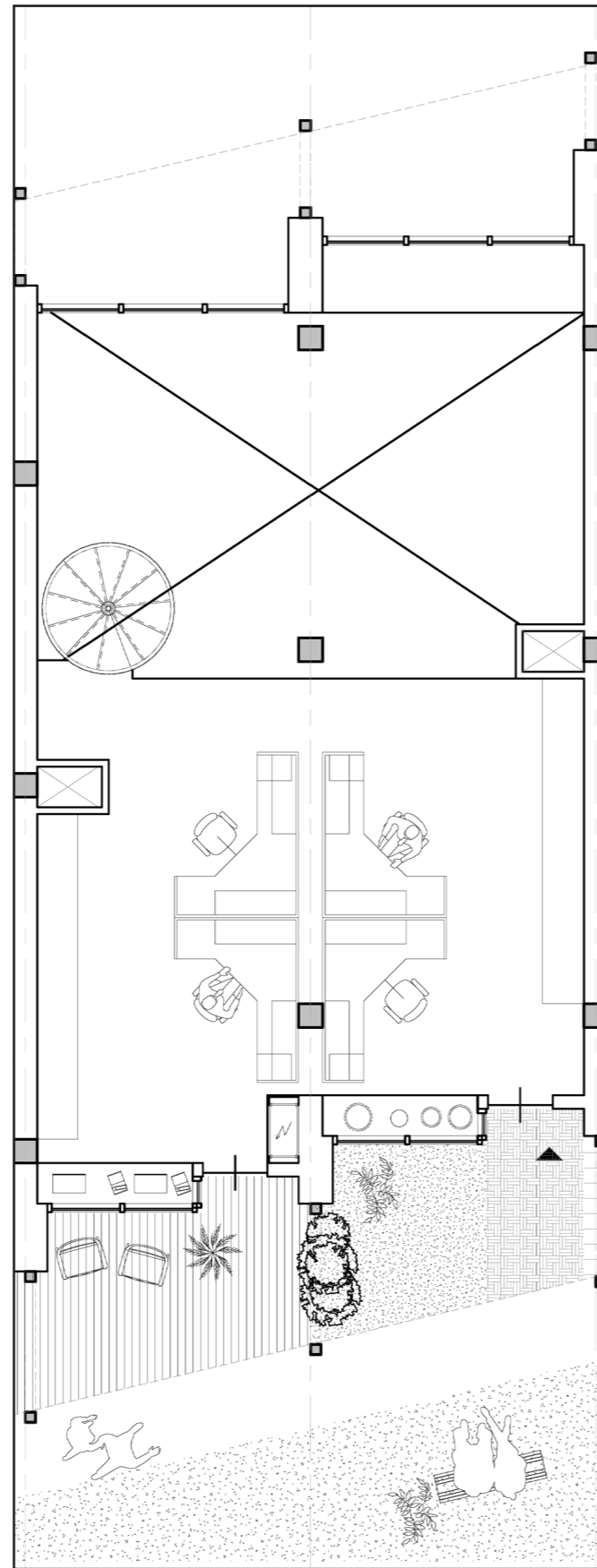

NouJIJ! - disassembly space 1:100

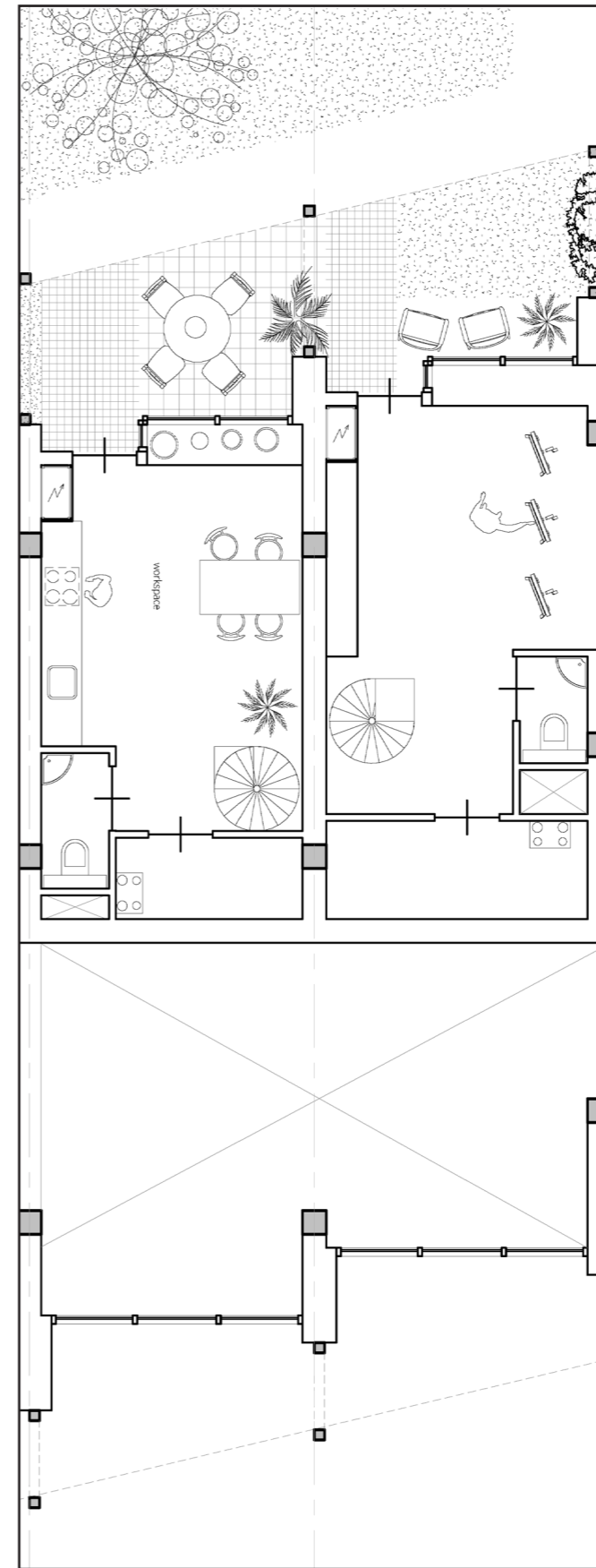

Atelier dwellings 1:100

8th floor

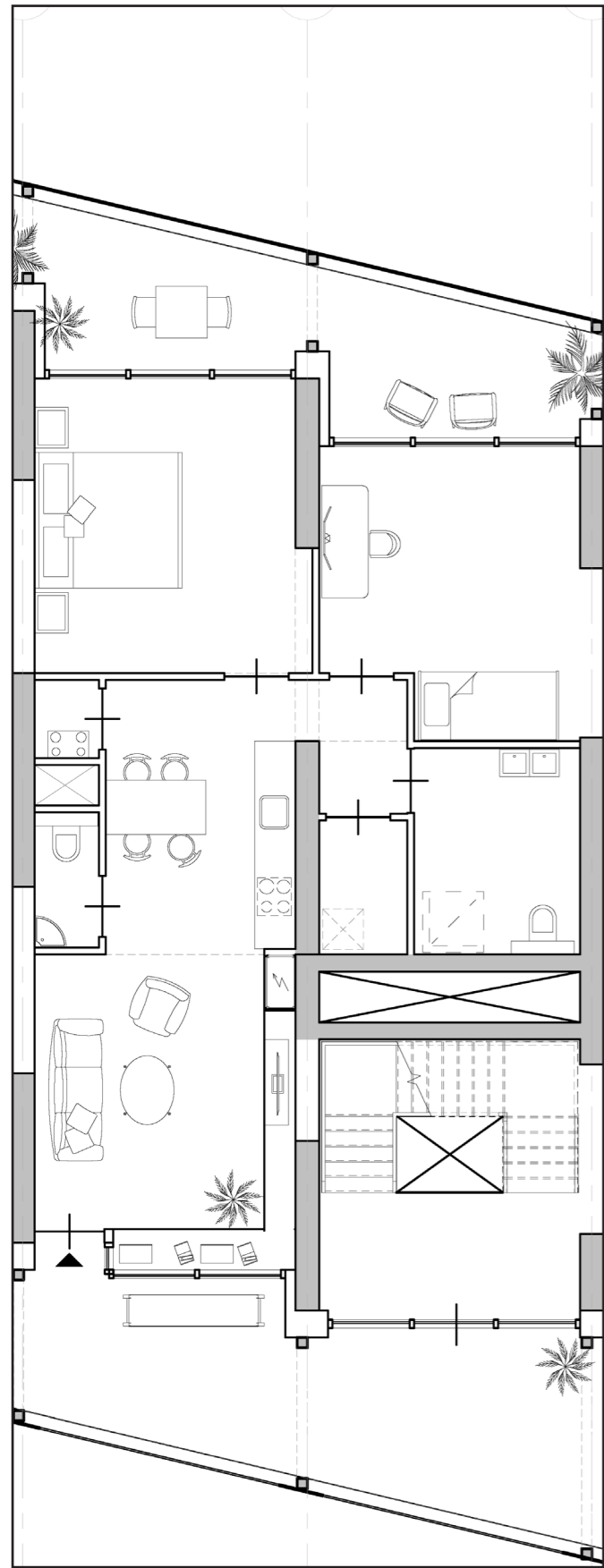

Corner apartment 1:100

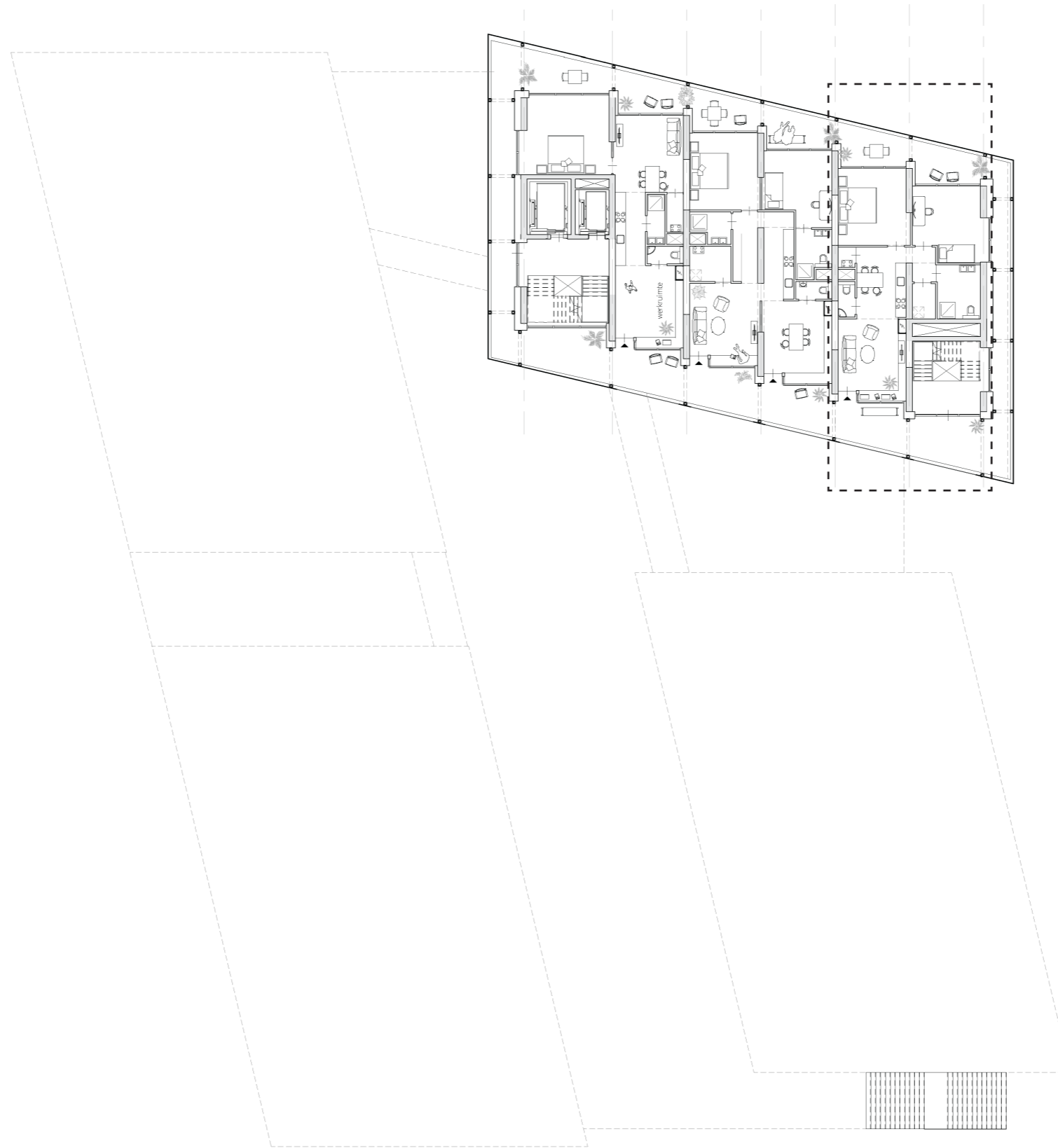

SECTIONS

SECTION



SECTION IMPRESSION PLINTH

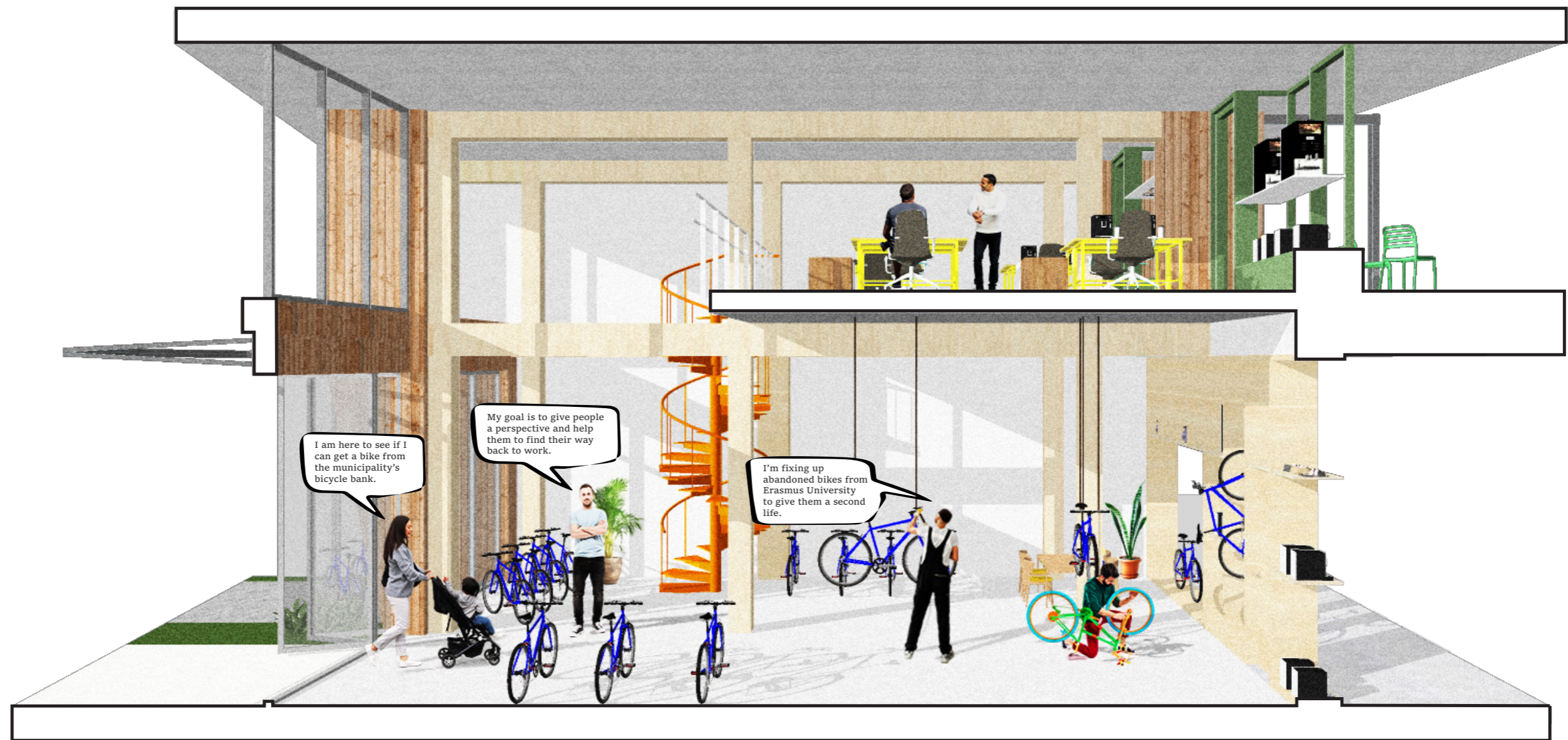

SECTION IMPRESSION LIVE/WORK APARTMENTS



BUILDING TECHNOLOGY

Facade fragment - scaled to 1:75

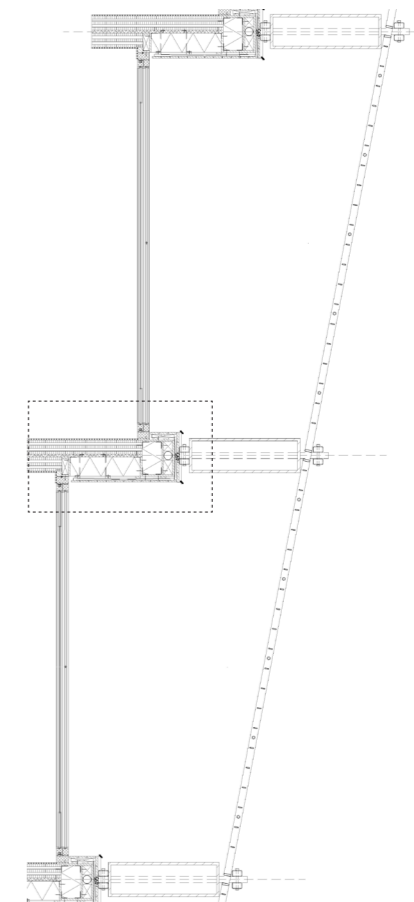
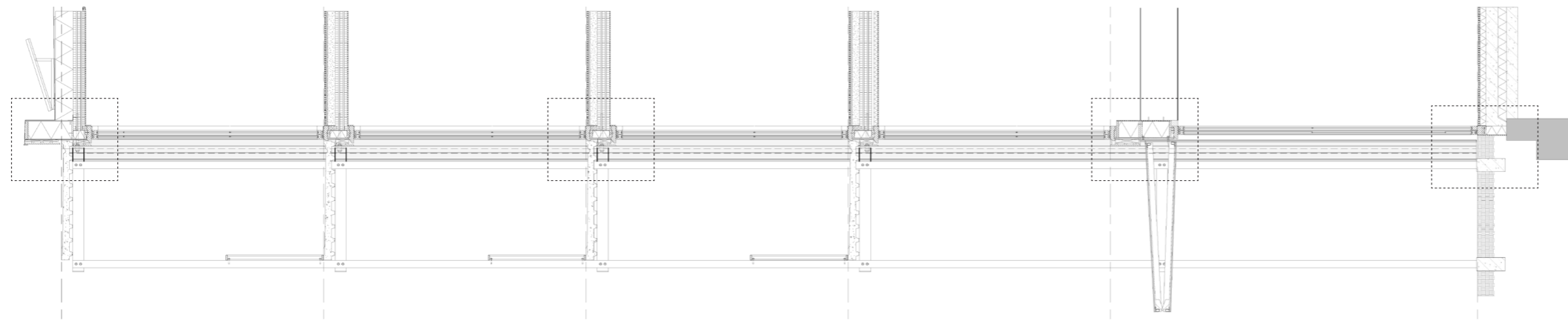

1:5 Detail foundation

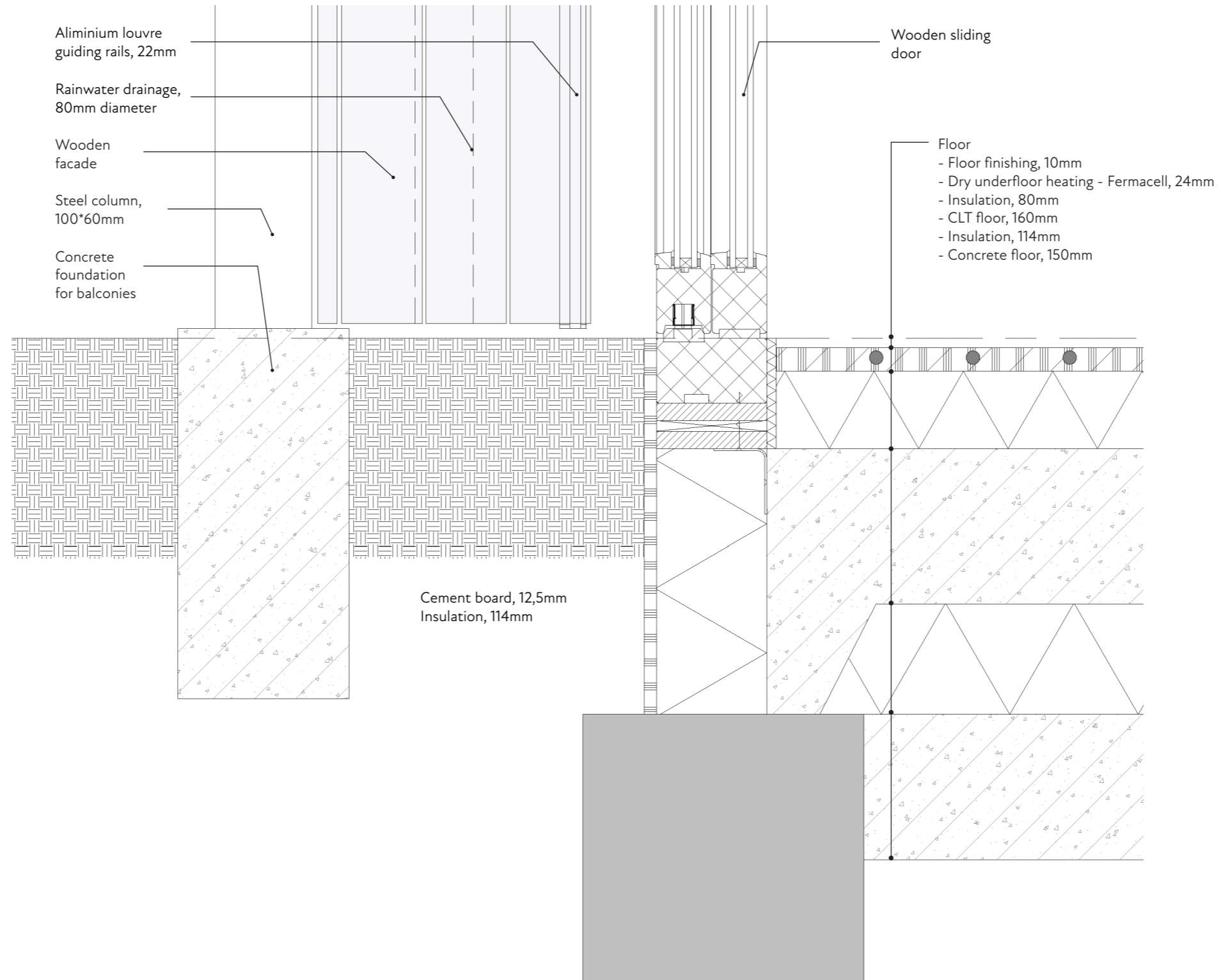

1:5 Detail plinth

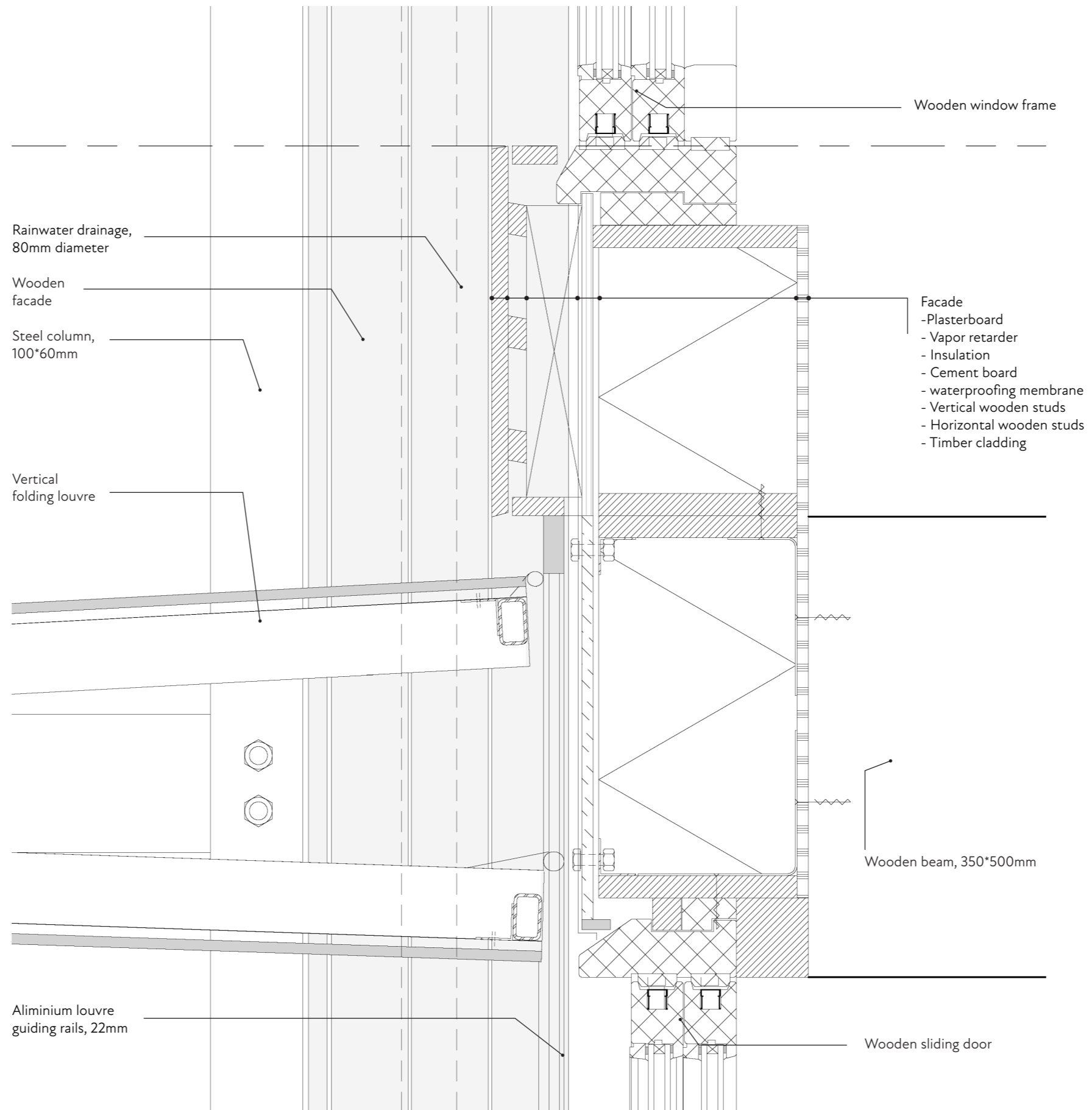

1:5 Detail 3rd floor

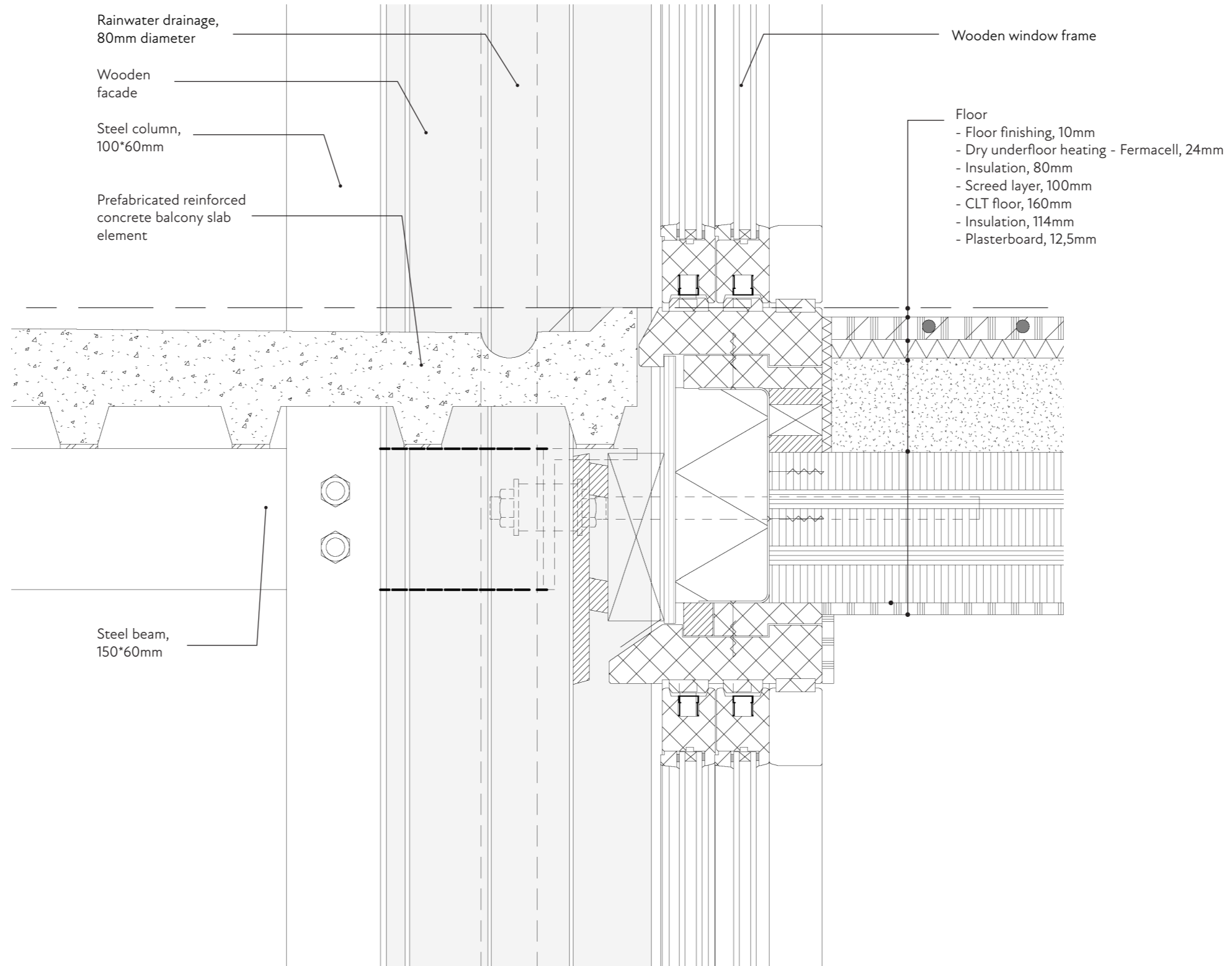

1:5 Detail roof

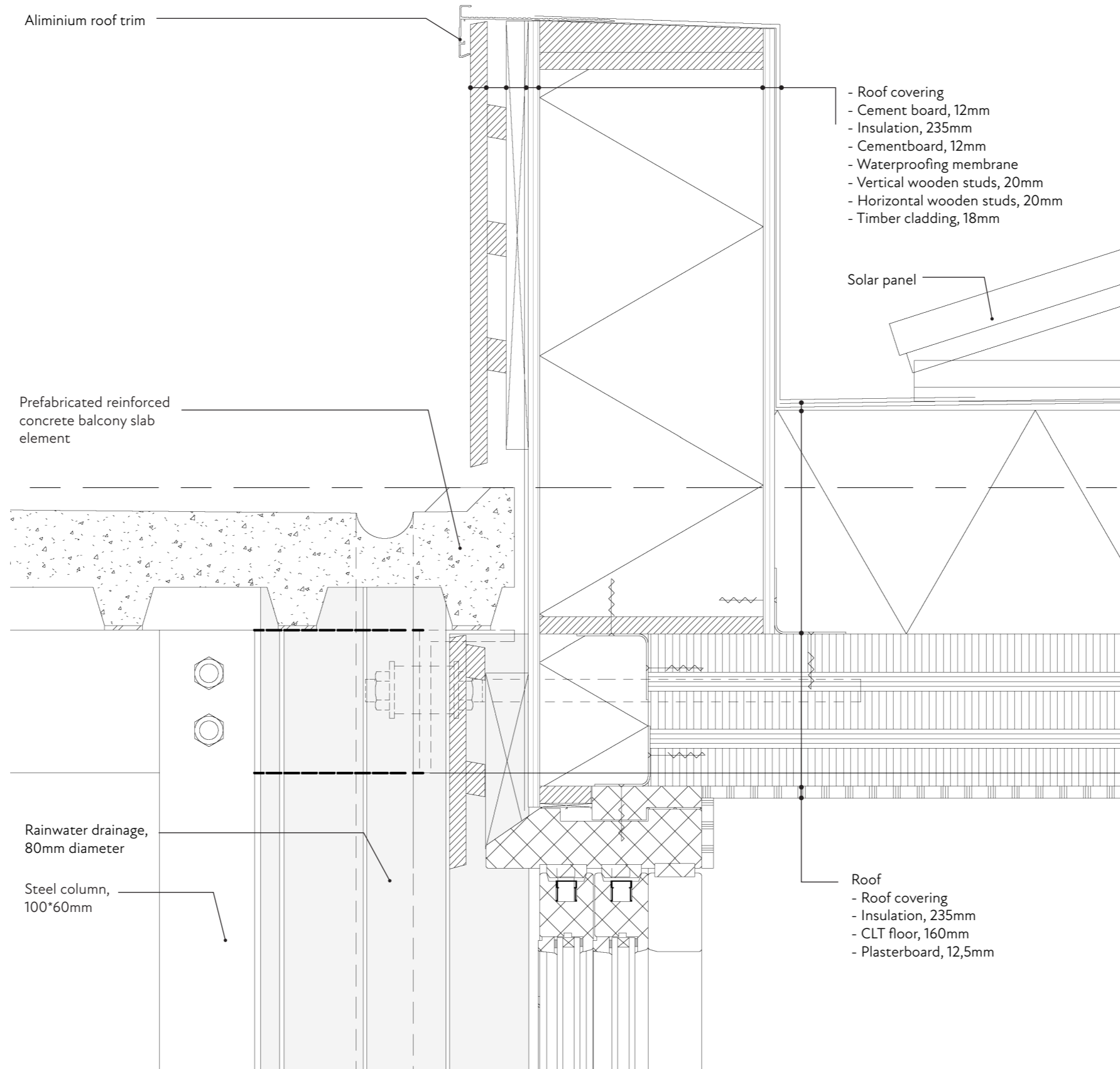

1:5 Horizontal detail

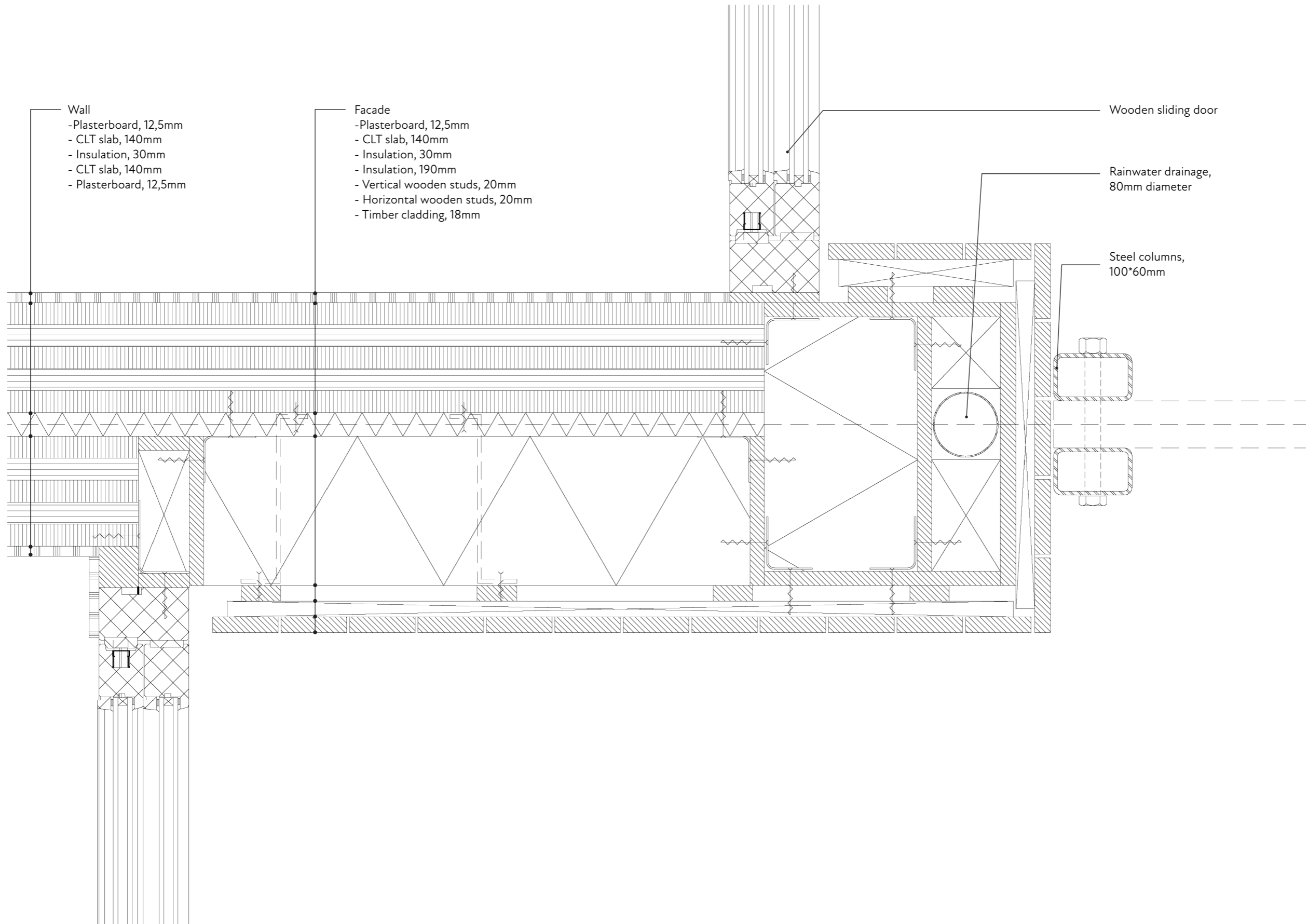

CONSTRUCTION AND CLIMATE

Installation & climate concept

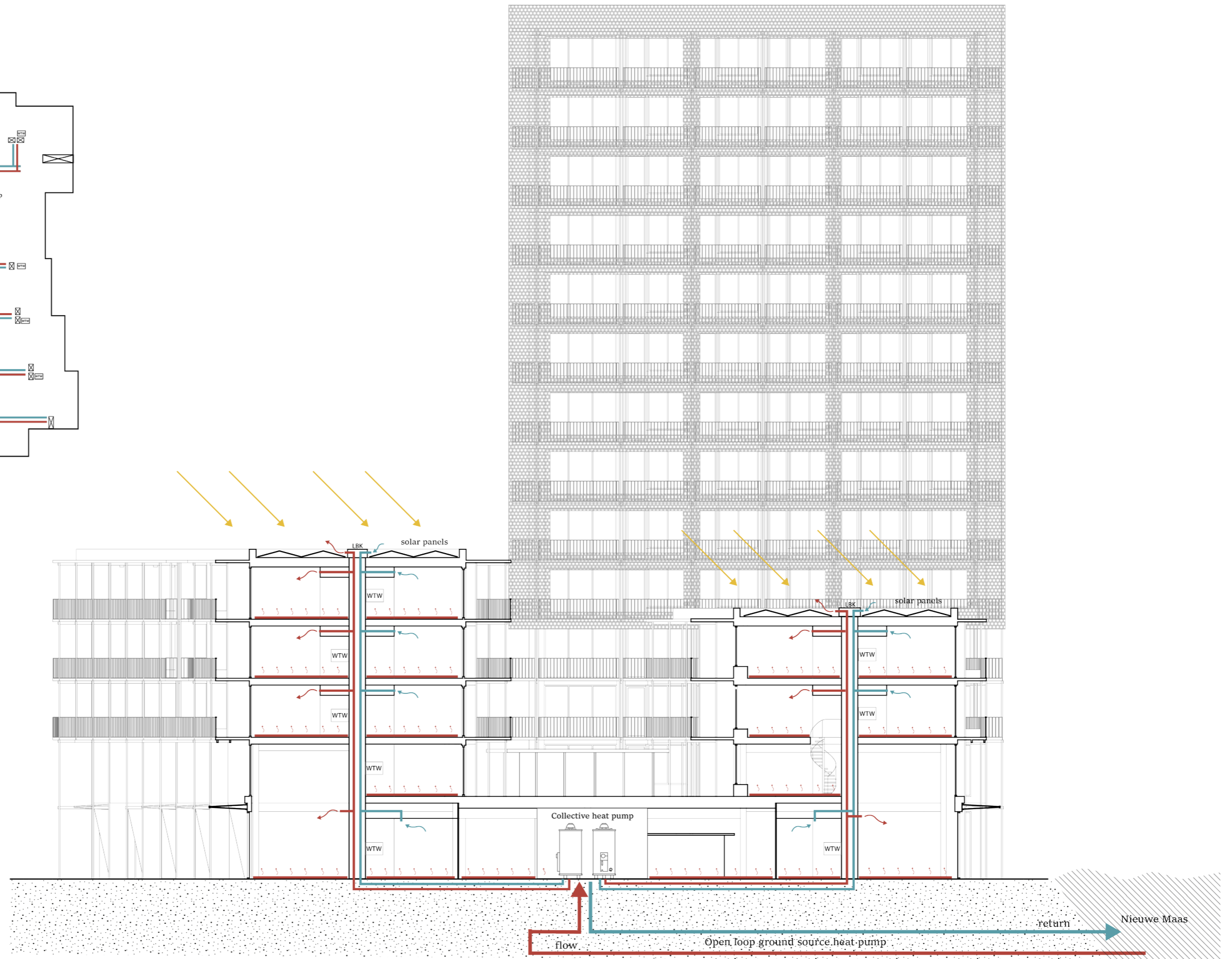
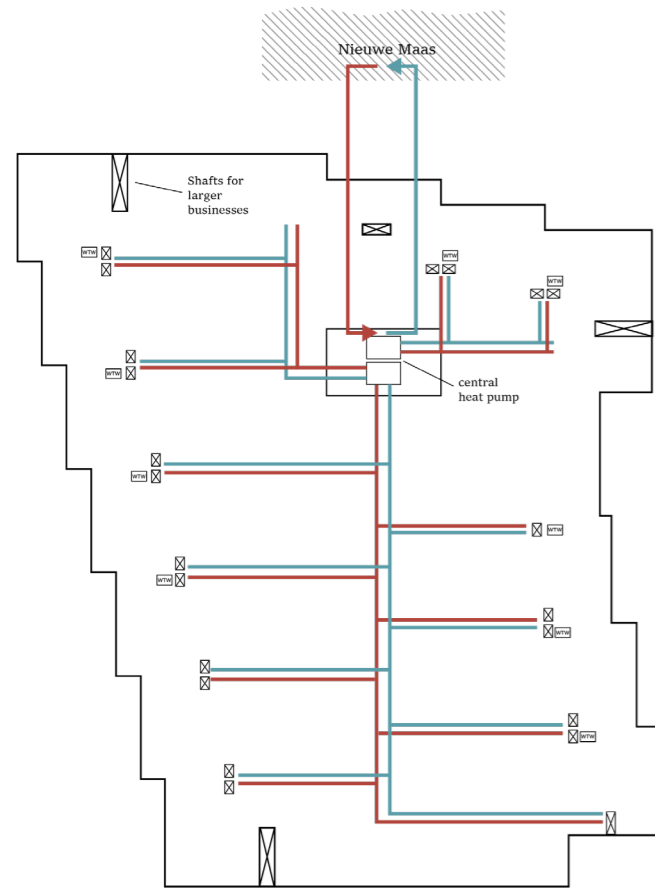

Installation & climate concept

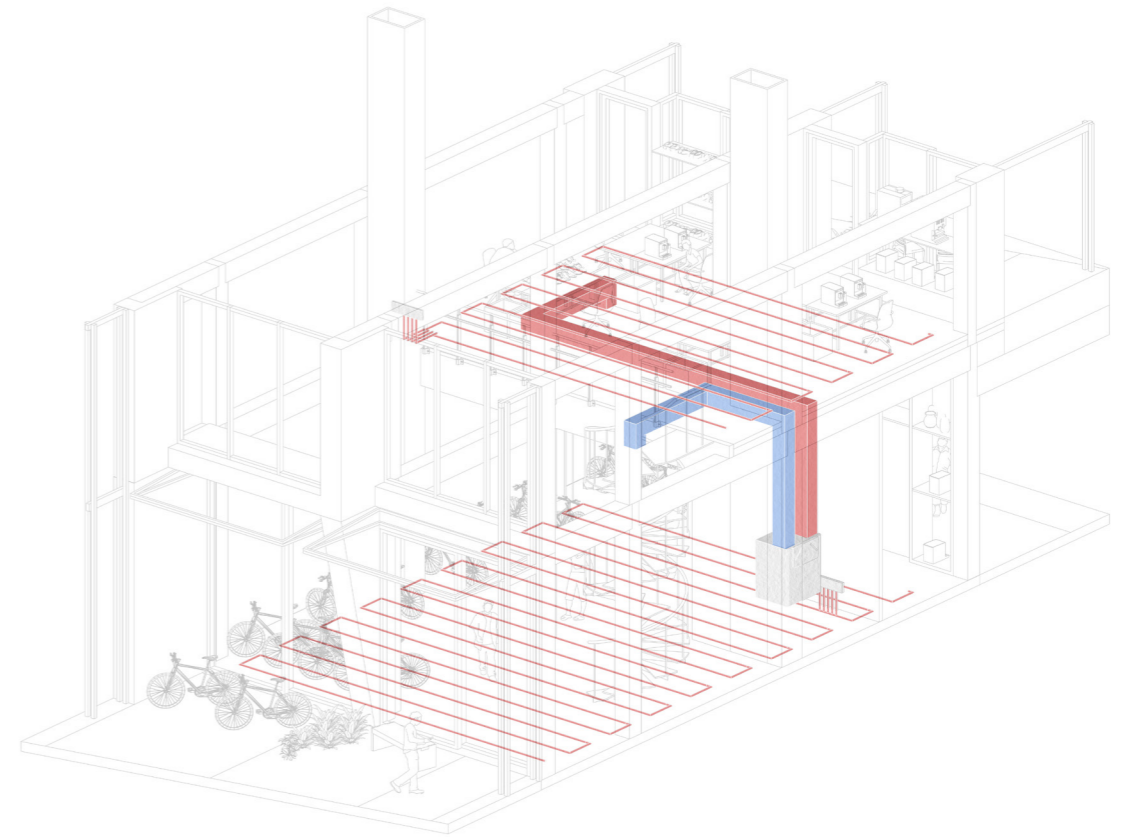
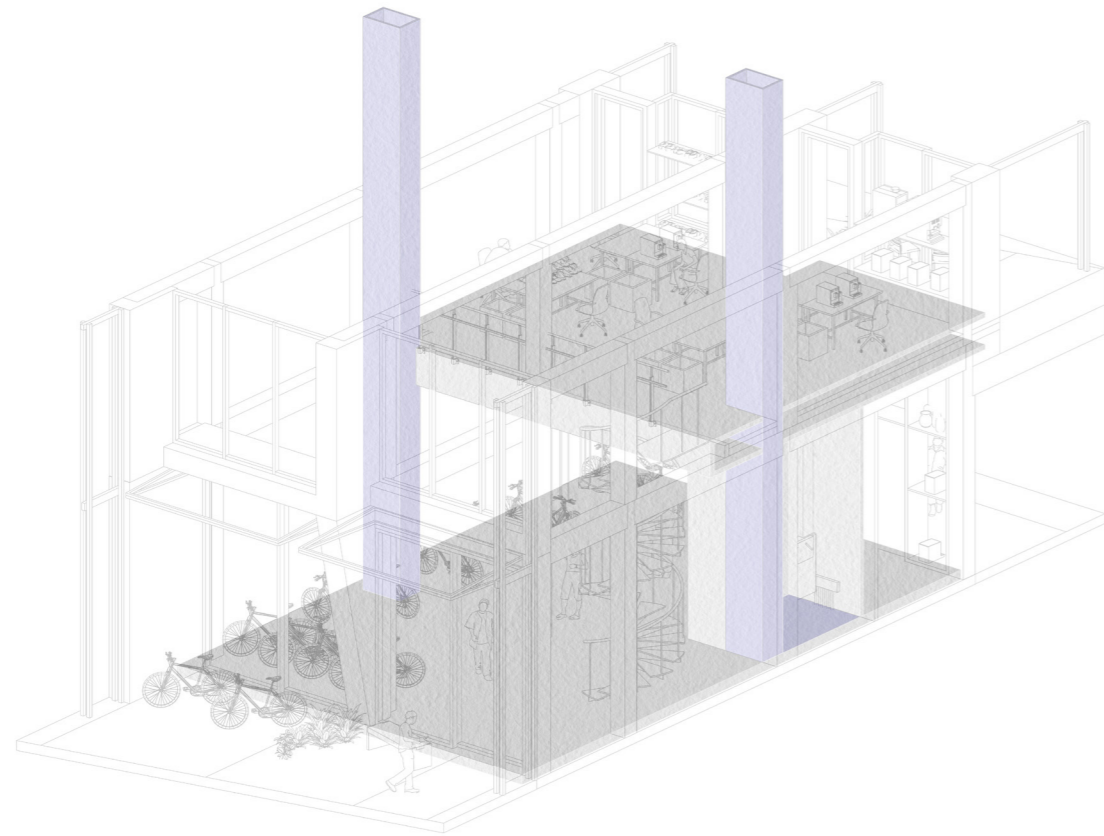

Plinth

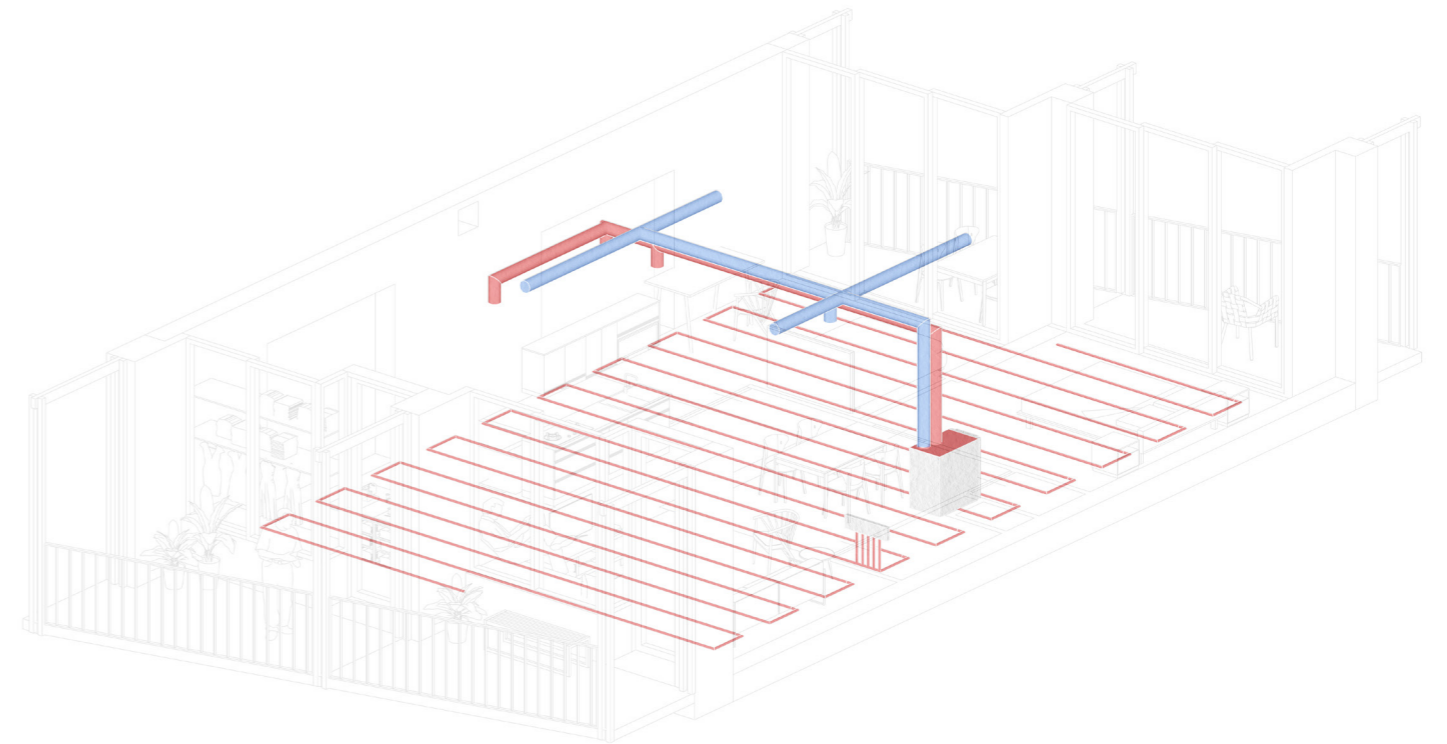
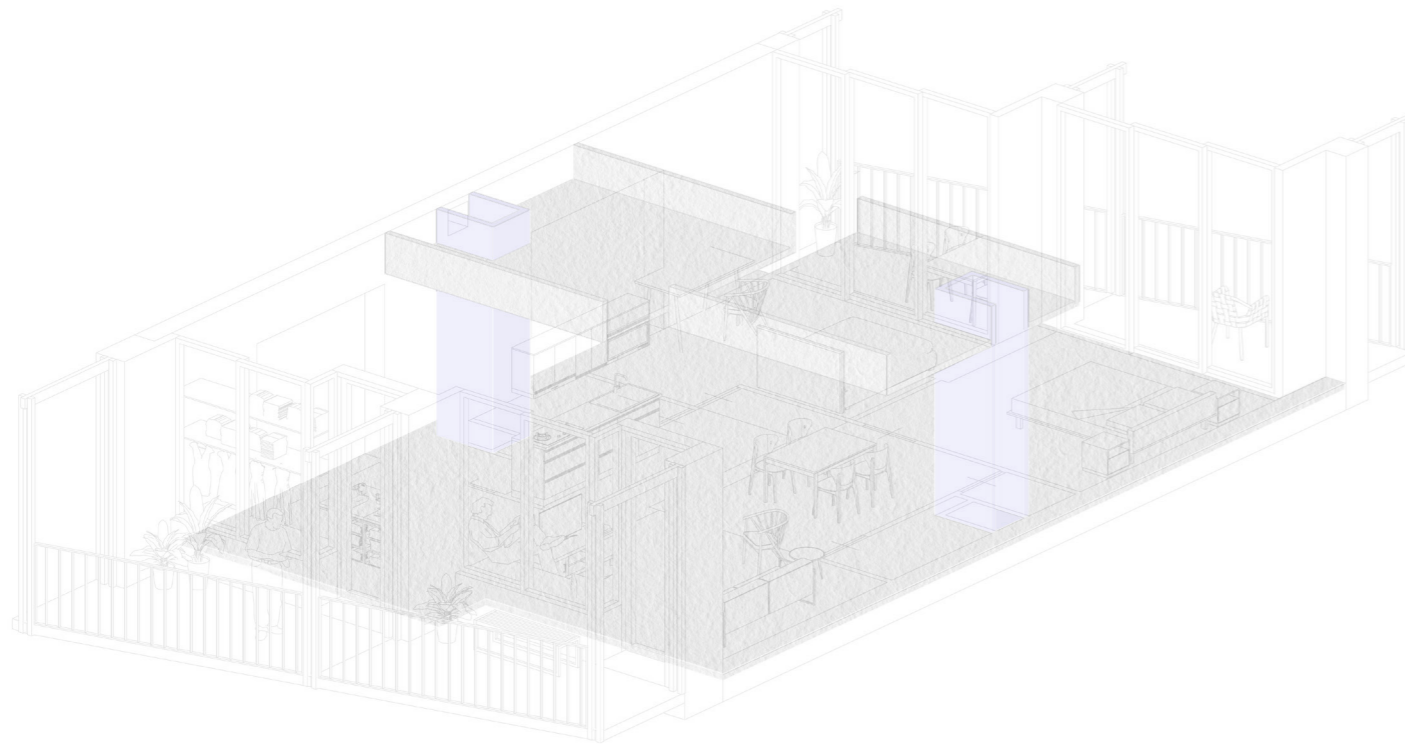

Upper floors

Construction concept

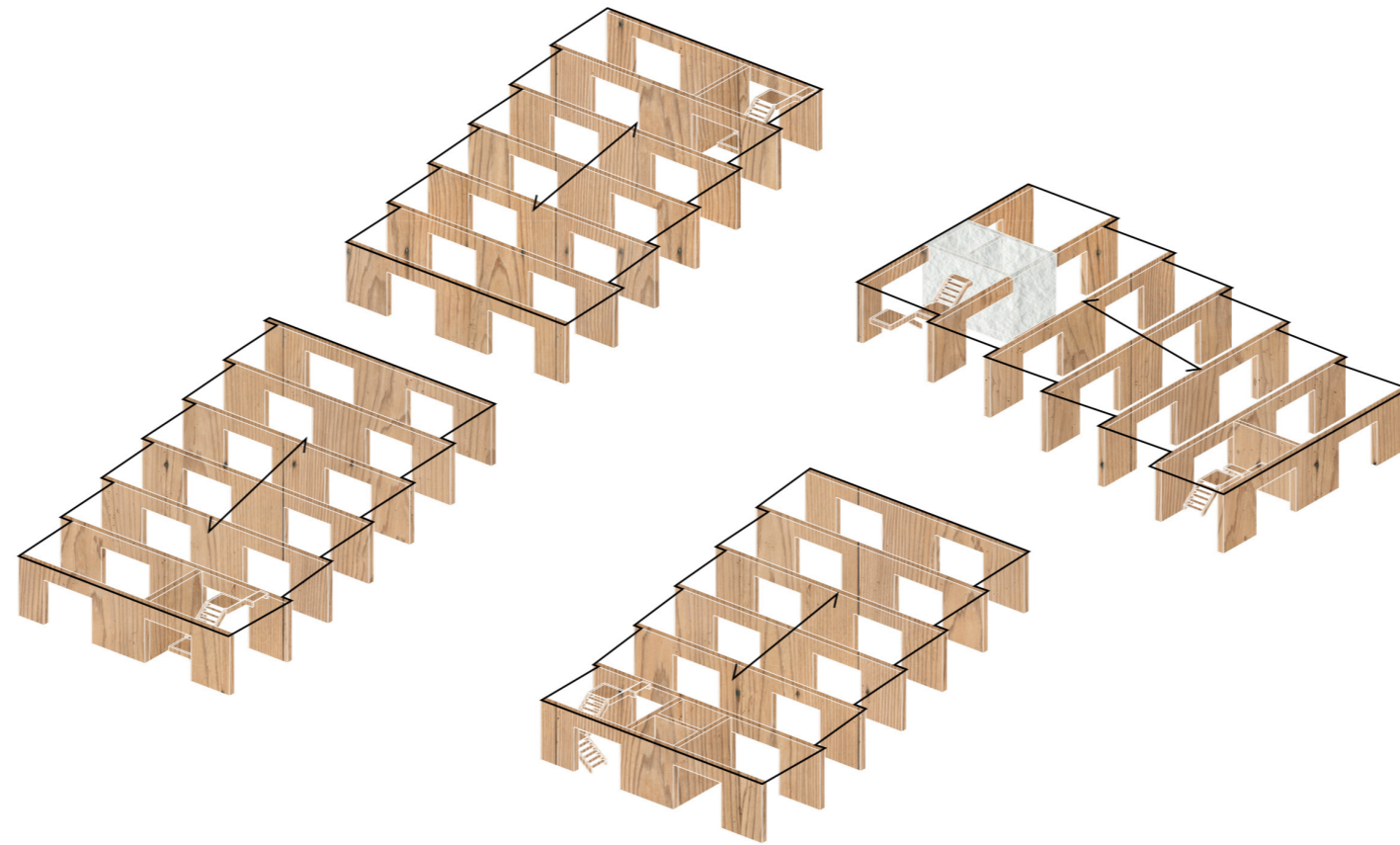

2nd-12th floor - CLT slabs with concrete core

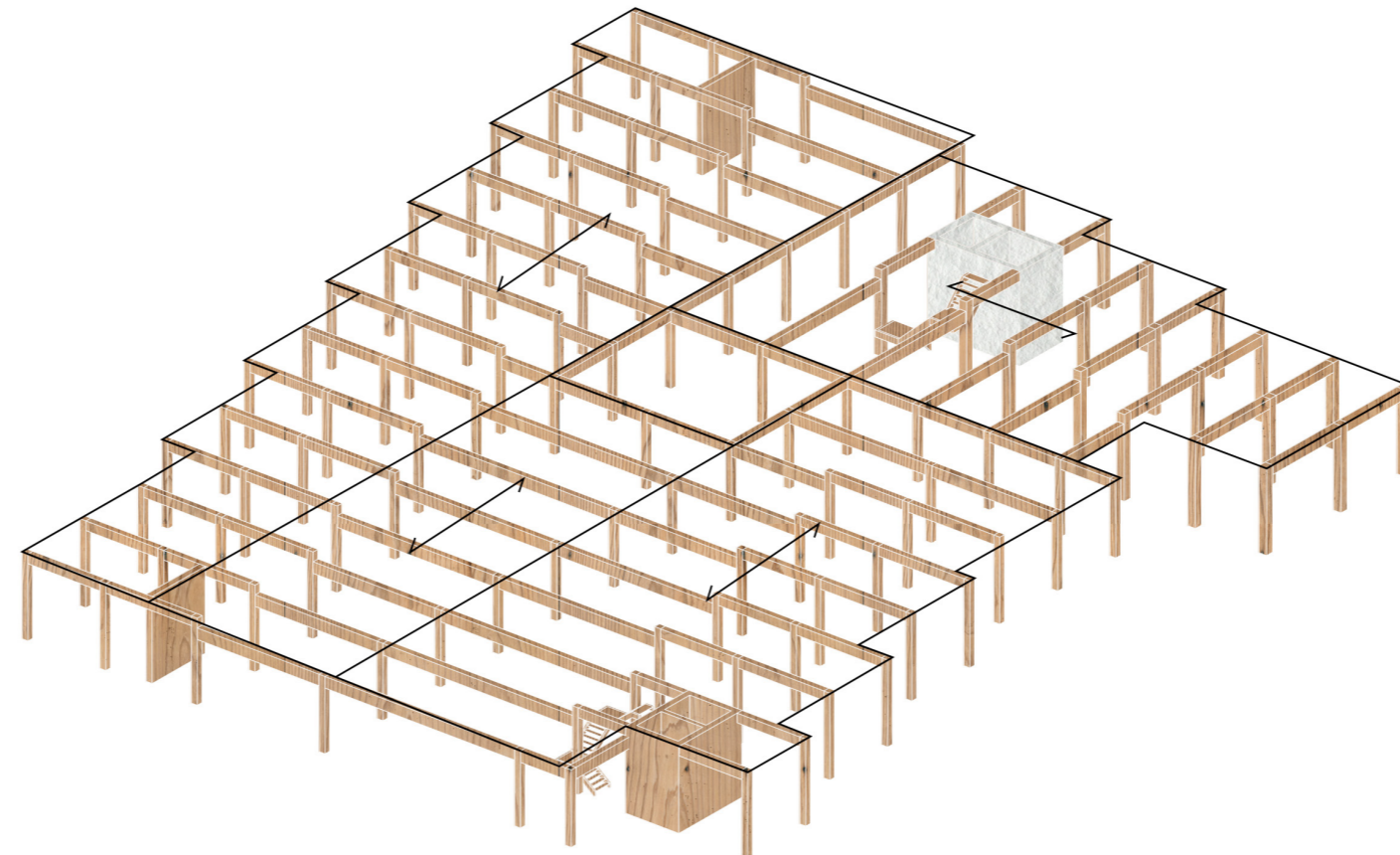
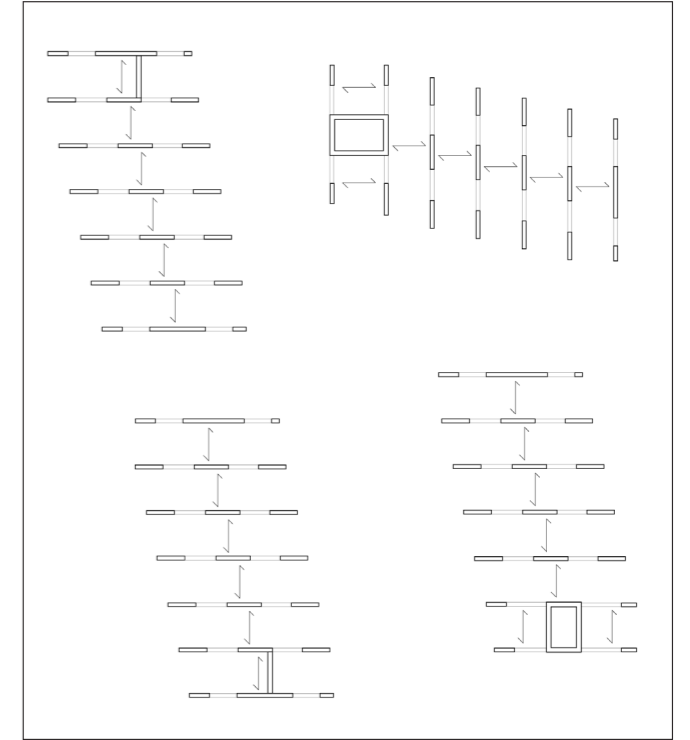

Ground & 1st floor - Wooden columns and beams

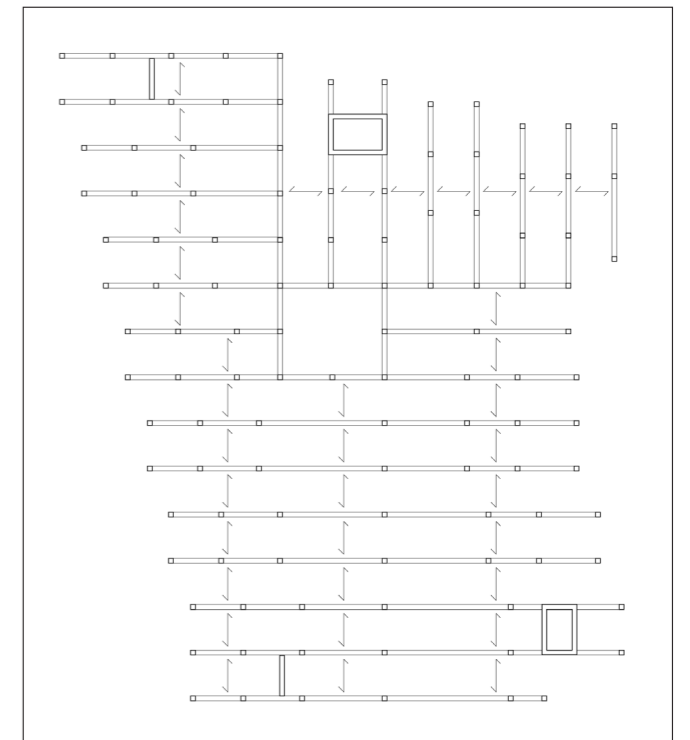

Construction concept

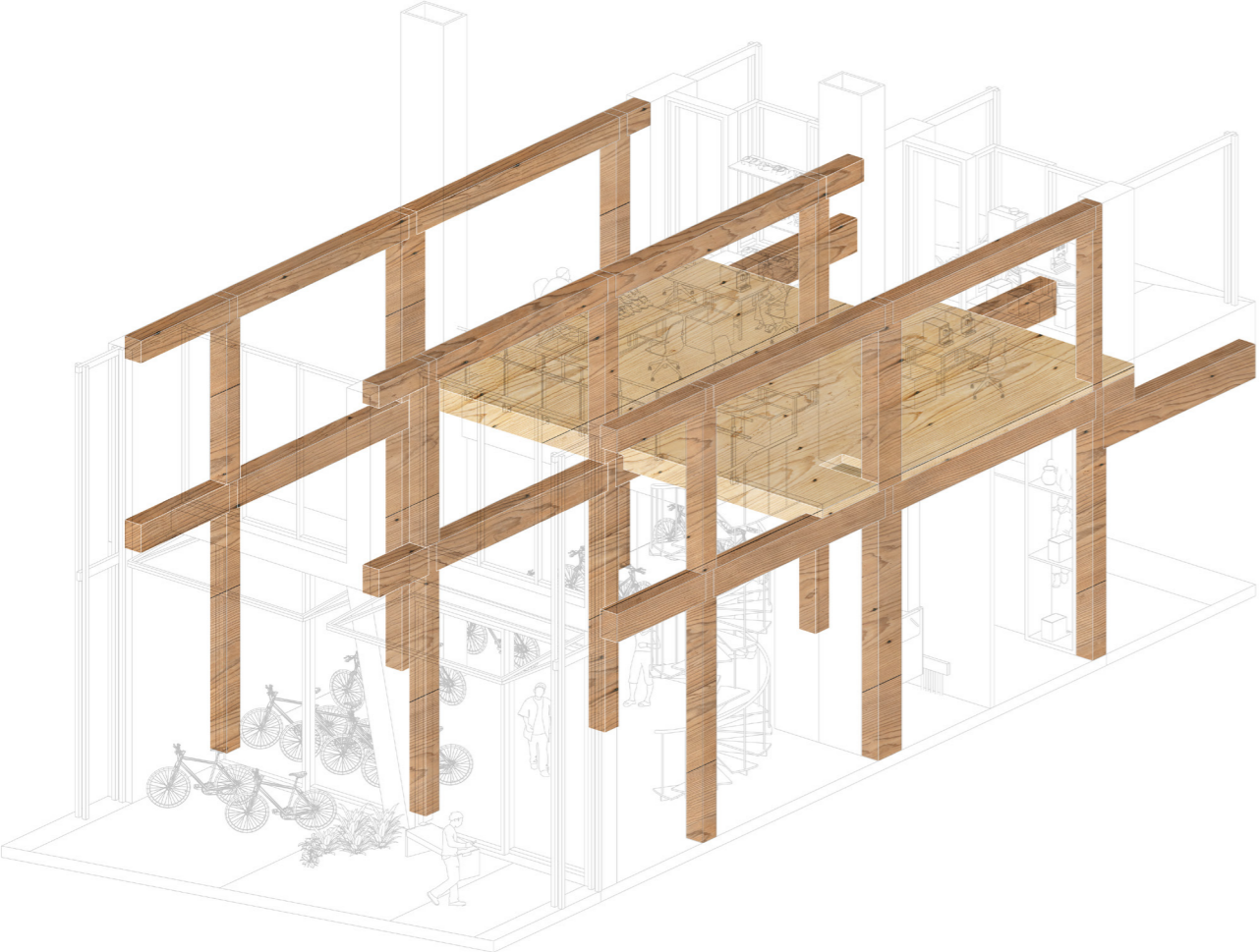

Plinth

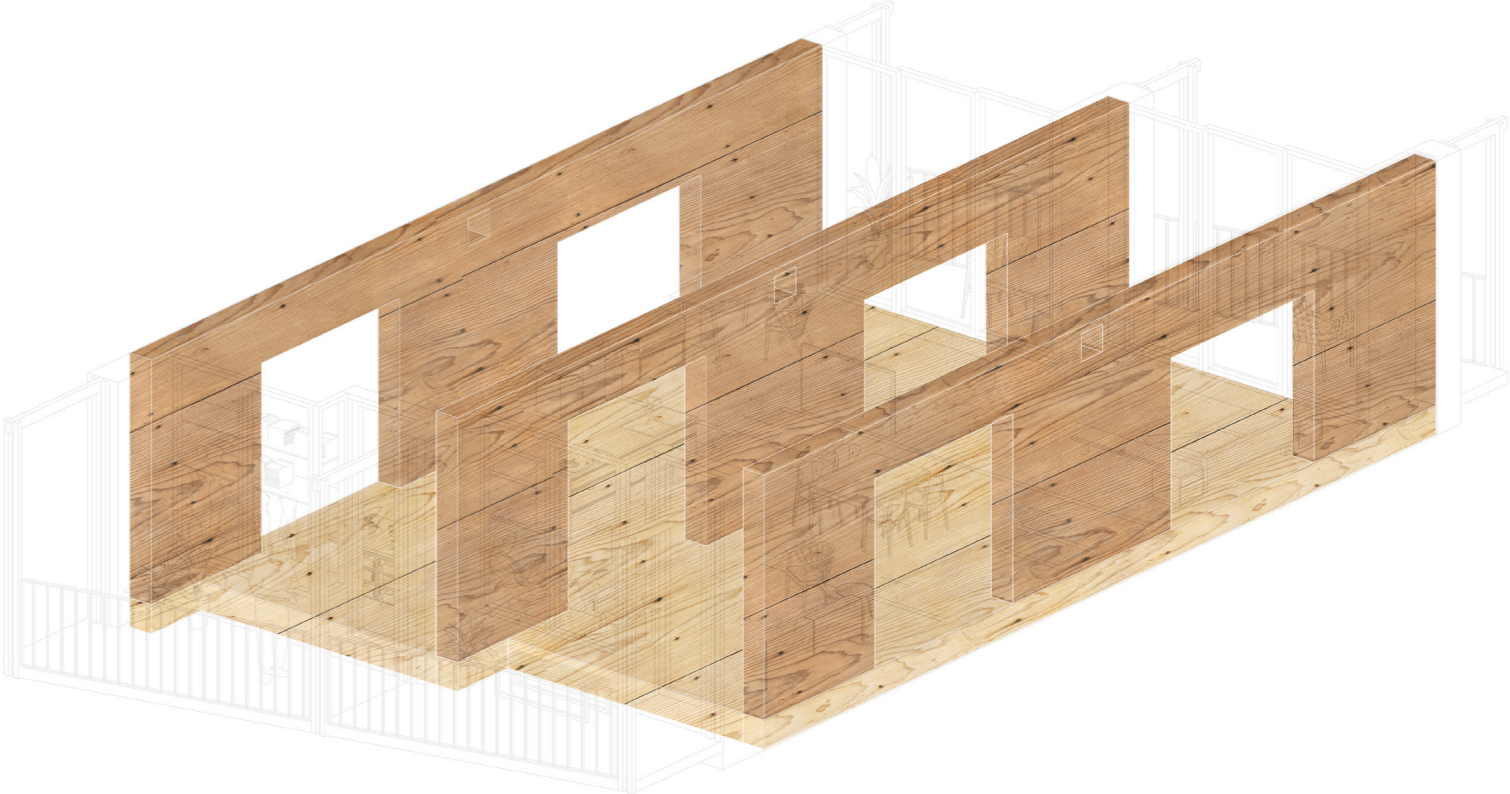

Upper floors

Facade impression business street



Facade impression live/work gallery



Facade impression tower



Impression square

