

Ports and Terminals

Ligteringen, H.

DOI

[10.5074/T.2021.005](https://doi.org/10.5074/T.2021.005)

Publication date

2022

Document Version

Final published version

Citation (APA)

Ligteringen, H. (2022). *Ports and Terminals*. TU Delft OPEN Publishing. <https://doi.org/10.5074/T.2021.005>

Important note

To cite this publication, please use the final published version (if applicable).
Please check the document version above.

Copyright

Other than for strictly personal use, it is not permitted to download, forward or distribute the text or part of it, without the consent of the author(s) and/or copyright holder(s), unless the work is under an open content license such as Creative Commons.

Takedown policy

Please contact us and provide details if you believe this document breaches copyrights.
We will remove access to the work immediately and investigate your claim.

Ports and Terminals

Han Ligteringen



Ports and Terminals

Ports and Terminals

H. Ligteringen

**Faculty of Civil Engineering and Geosciences
Delft University of Technology**

Delft Academic Press



©TU Delft

Print version published by Delft Academic Press / VSSD
Leeghwaterstraat 42, 2628 CA Delft, The Netherlands
tel. +31 15 27 82124
dap@vssd.nl
www.delftacademicpress.nl/f031.php

ISBN Ebook: 978-94-6366-470-7
Printed version: 97890-6562-4147
NUR 957
Key words: ports and terminals

This Open Textbook is licensed under a
[Creative Commons Attribution - NonCommercial NoDerivatives License](#).

Online edition 2021 Published by TU Delft Open
ISBN 978-94-6366-470-7
DOI: <https://doi.org/10.5074/T.2021.005>

This open textbook is a digital copy of the print version that was published by Delft Academic Press in 2017. Great care has been taken to locate and acknowledge all owners of copyrighted material in this book. If any such owner has inadvertently been omitted, acknowledgement will gladly be made in future editions of this work. If this is the case, please contact educationsupport-lib@tudelft.nl

Preface

Former students of Delft University of Technology, who followed the lectures Ports and Waterways in the Master Hydraulic Engineering will recognize this text book as one of the readers they had to digest. It was and will be used in that course, but as there was also much interest from other universities and practitioners in the Netherlands and abroad it was converted into a published version in 2012 .

The foundation of the book was laid by Hugo Velsink during his years as professor Ports and Waterways in the Faculty of Civil Engineering at Delft University of Technology. As his successor in 1995 I continued to use the reader and updated it from time to time. The 2012 edition was still a joint production, but in the preparations of this new edition Hugo left the honor to me. However, the results of his vast experience in port planning and design are there and are whole-heartedly acknowledged.

This new edition became necessary due to the rapid developments in some areas such as container ships and terminals, but also to include the results of research carried out by my successor, Tiedo Vellinga, and members of his group, who are using the book in their lectures in Delft. The contributions of him, Poonam Taneja, Cornelis van Dorsser, Bas Wijdeven and Peter Quist are greatly appreciated and acknowledged in the chapters. Furthermore several recent PIANC Working Group Reports provided valuable information for this edition, such as the Design Guidelines for Harbour Approach Channels.

The new cover photograph shows a part of the Port of Rotterdam with the city in the background. One sees the channels and different types of terminals that are treated in the book. This is to acknowledge the fact that throughout the years the Port of Rotterdam has been a highly valued partner for the University and the Civil Engineering Faculty in particular, providing training places and guest lecturers on specialized subjects, and collaborating in research projects of Port Research Centre and Smart Ports.

Delft, Summer 2017 Han Ligteringen

Contents

Preface	v
List of symbols	xiii
1 Introduction	1
2 Maritime Transport	3
2.1 Introduction	3
2.2 Specific Data of Merchant Ships	5
2.2.1 Transport Capacity	5
2.2.2 Vertical Dimensions	7
2.2.3 Horizontal Dimensions	8
2.2.4 Other Relevant Data	9
2.3 Commodities and types of vessels	10
2.3.1 Introduction	10
2.3.2 Break-bulk or Conventional General Cargo	11
2.3.3 Container Vessels	16
2.3.4 Ro/Ro Vessels	19
2.3.5 Car Carriers and Other Special Vessels	22
2.3.6 Bulk Cargo	28
2.3.7 Short Sea Trader	36
2.4 Tramp and Liner Trade	37
2.4.1 Liner Trade	37
2.4.2 Tramp Trade	38
2.5 Graphs and Observations	38
2.6 References	44
3 Port Functions and Organisation	45
3.1 Introduction	45
3.2 Functions	45
3.3 Transport Chain	48
3.4 Organisation of Seaports	49
3.5 References	50
4 Port Planning Methodology	53
4.1 Introduction	53
4.2 Types of Planning	53
4.3 Overall Planning Process	56
4.4 Permits and Legal framework	58
4.5 Technical Planning	60
4.5.1 Cargo and Shipping Projections	61

4.5.2 Functional Requirements and Planning Elements	62
4.5.3 Site Data	63
4.5.4 Layout Development	66
4.5.5 Project Evaluation	69
4.5.6 Financial and economic analysis	71
4.5.7 Project Optimisation	79
4.6 Sustainable port development	82
4.7 Adaptive Port Planning (Planning under Uncertainty)	87
4.7.1 Why Adaptive Port Planning?	87
4.7.2 Steps in Adaptive Port Planning	88
4.7.3 Comparison of the planning approaches	90
4.8 Concluding remarks	90
4.9 References	92
5 Planning and Design of the Water Areas	95
5.1 Introduction	95
5.2 Ship Manoeuvring and Hydrodynamic Behaviour	96
5.2.1 Basic Manoeuvrability	96
5.3 Approach Channels	111
5.3.1 Alignment	111
5.3.2 Channel Width	114
5.3.3 Channel Depth	116
5.4 Manoeuvring Areas within the Port	122
5.5 Port Basins and Berth Areas	125
5.5.1 Nautical Aspects	125
5.5.3 Harbour Basin Resonance	130
5.6 Morphological Aspects	131
5.6.1 Littoral Transport	131
5.6.2 Siltation of Approach Channels	133
5.6.3 Sedimentation inside the Port	134
5.7 References	135
6 Planning and Design of Port Terminals	137
6.1 General	137
6.2 Services Provided	137
6.3 Terminal Components	138
6.4 Types of Terminals	139
6.5 Terminal Capacity: Maximum or Optimum	148
6.6 Terminal Dimensions	149
6.6.1 Quays and Jetties	150
6.6.2 Terminal Areas	151
6.7 References	152

7 Container Terminals	153
7.1 Introduction	153
7.1.1 Historical development of container transport	153
7.1.3 Disadvantages of containerisation	158
7.1.4 Major transport routes	159
7.1.5 Global container throughput	161
7.2 Container types and container vessels	162
7.2.1 Container types and sizes	162
7.2.2 Container vessels	165
7.2.3 Global ocean carriers	169
7.2.4 Terminal operators	169
7.3 Container terminal operations	170
7.3.1 Terminal processes and equipment	170
7.3.2 Container flows and modal split	183
7.3.3 Terminal archetypes	186
7.3.4 Size of the container terminal	186
7.3.5 Terminal automation	189
7.4 Layout development	191
7.4.1 Container terminal components	191
7.4.2. Typical container terminal layout	191
7.4.3 Quay length and number of STS cranes	197
7.4.4 Apron area	200
7.4.5 Storage yard	201
7.4.6 Container transfer area and buildings	206
7.4.7 Rail terminal	206
7.4.8 Facilitation of IWT container vessels	207
7.4.9 Other buildings	208
7.4.10 Simulation models	208
7.4.11 Terminal Operating System (TOS)	208
7.4.12 Security	209
7.5 References	211
8 General Cargo and Multipurpose Terminals	213
8.1 Introduction	213
8.2 Non-containerised General Cargo	214
8.2.1 Types of General Cargo	214
8.2.2 Terminal Logistics	215
8.3 Number of Berths and Quay Length	216
8.4 Storage Area and Overall Terminal Lay-out	218
8.5 Multipurpose Terminals	221

8.6 References	223
9 Ro/Ro and Ferry Terminals	225
9.1 Introduction	225
9.2 Lay-out Ro/Ro and Ferry Terminals	226
9.2.1 Ferry Terminal	226
9.2.2 Ro/Ro Terminals	228
9.3 Special Design Aspects	229
9.3.1 Ramp and Bridges	229
9.3.2 Bottom Protection	232
9.4 References	233
10 Liquid Bulk Terminals	235
10.1 Introduction	235
10.2 Oil Tankers and Gas Carriers	235
10.2.1 Oil Tankers	235
10.2.2 Liquid Gas Carriers	235
10.3 The Nature of the Products	237
10.4 Terminals	238
10.4.1 General	238
10.4.2 Types of Terminals	239
10.4.3 Location of the Terminal - Safety Considerations	241
10.5 The Berth	243
10.6 Jetties and Dolphins	244
10.6.1 L and T Jetties	244
10.6.2 Finger Piers	246
10.6.3 Approach Bridges and Jetty Heads	247
10.6.4 Breasting Dolphins	247
10.6.6 Special Aspects of LPG/LNG Jetties	254
10.7 Storage Areas	255
10.8 Offshore Facilities	255
10.8.1 Multiple Buoy Mooring (MBM)	255
10.8.2 Single Buoy Mooring (SBM)	257
10.9 References	259
11 Dry Bulk Terminals	261
11.1 Introduction	261
11.2 Dry Bulk Commodities	261
11.3 Dry Bulk Ships	263
11.4 Unloading Systems	264
11.4.1 General	264
11.4.2 Grabs	265

Contents

11.4.3 Pneumatic Systems	267
11.4.4 Vertical Conveyors	268
11.4.5 Bucket Elevators	271
11.4.6 Slurry Systems	274
11.4.7 Self-unloading Vessels	275
11.5 Loading Systems	275
11.6 On-terminal Handling and Storage	277
11.6.1 Transport Systems	277
11.6.2 Stacking, Storage and Reclaiming	278
11.6.3 Blending, Processing, Weighing	281
11.7 Design Aspects of Dry Bulk Terminals	282
11.8 Climatic and Environmental Considerations	282
11.9 References	283
12 Fishery Ports	285
12.1 Introduction	285
12.2 Types of Fishery Ports	285
12.2.1 Simple Landing Places	285
12.2.2 Coastal Fishery Ports	286
12.2.3 Near-distance Fishery Ports	286
12.2.4 Ocean Fishery Ports	288
12.3 Site Selection	289
12.4 Fishing Vessels	290
12.5 Port Planning	293
12.5.1 Access Channels	293
12.5.2 Basins and Berths	294
12.6 Unloading Equipment	305
12.7 Fishery Port Organisation and Management	307
12.8 References	307
13 Marinas	309
13.1 Yachting and Yachts	309
13.2 General Lay-out of the Port	312
13.3 Basins and Berths	313
13.4 Port Structures	316
13.5 References	318
14 Ports and Terminals for Inland Water Transport	319
14.1 Location and Lay-out of IWT Ports	319
14.2 The Vessels	319
14.2.1 General	319
14.2.2 The European Waterways	320

14.3 Types of Ports	323
14.3.1 Open River Ports	323
14.3.2 Closed River Ports	324
14.3.3 Canal and River Ports: Lay-out and Dimensions	327
14.4 Terminals	329
14.4.1 IWT Cargo Terminals	329
14.4.2 Cargo Handling	330
14.4.3 Storage	331
14.4.4 IWT Jetties on Rivers with a Large Seasonal Water Level Variation	331
14.4.5 Design Aspects for a Simple IWT Canal Berth	334
14.4.6 Inland Passenger Terminals	337
14.4.7 Seaport Terminals for IWT Vessels and Lighters	338
14.5 References	338
Adaptive Port Planning applied to port expansion project MV2	339
1 Background	339
1.1 Project description	339
1.2 The Master Plan and Business Case	339
1.2.1 Objectives	340
1.2.2 Dealing with uncertainty	341
2 Adaptive Port Planning	341
2.1 Step Ia: Define the project	342
2.1.1 Definition of Success	342
2.1.2 Major assumptions	343
2.1.3 Step II: Identify load-bearing and vulnerable assumptions underlying the plan	343
2.1.4 Step III: Increasing the flexibility and robustness of the plan	347
2.1.5 Certain developments	347
2.1.6 Step IV: Evaluate and select alternative	349
2.1.7 Step V: Set up a monitoring system	349
2.1.8 Step VI: Contingency planning for the selected plan	352
3 Adaptive port plan	352
3.1 Impact-Probability chart	352
3.1.1 (fairly) Certain developments	353
3.1.2 Wildcard or trend-break developments	354
3.1.3 Uncertain developments	354
4. References	357
Index	359

List of symbols

Parameter	Unit	Description
a	m	vertical motion due to wave response
A	m^2	surface area
A_{cf_s}	m^2	surface area of the CFS
A_{ch}	m^2	chamber floor area (horizontal); channel wet cross-sectional area
A_{gr}	m^2	gross storage area
A_L	m^2	longitudinal above water area
A_s	m^2	vessel cross-sectional area in the plane of the water surface; used in squat calculation
A_T	m^2	transverse above water area
A_{TEU}	m^2	required area per TEU inclusive of equipment travelling lanes
B_s	m	beam; width of a ship at the midships-section
c	m/s	celerity of an individual wave in unrestricted water
C	t/yr; TEU/yr	design annual throughput
c_a	m/s	apparent wave celerity
c_b	t/yr; TEU/yr	berth productivity per year
C_B	-	block coefficient
c_c	TEU	parcel size; the number of TEU (un)loaded per call
C_c	-	configuration coefficient; current force coefficient
C_c	currency	present day value
C_e	-	eccentricity coefficient

Ports and Terminals

C_m	-	added mass coefficient
C_{mx}, C_{my}	-	virtual mass coefficients
C_r	m/yr	resiltation factor
C_s	-	stiffness coefficient
$c_{s/h}$	t/hr	unloading rate per ship per hour
C_t	currency	annual costs in year t
C_w	-	waterplane area coefficient
D	m	draught; depth of non-moving ship; ship draught (for condition considered)
d_{50}	m	average grain size diameter; characteristic diameter bottom protection
D_{pl}	m^3	water displacement
DWT	t	deadweight tonnage
E	J	impact energy
f	Hz	actual wave frequency
F	N	force
f_{area}	-	ratio gross area over net area
f_{bulk}	-	bulking factor
f_r	-	irregularity factor for vessel arrival
f_{TEU}	-	TEU-factor
GRT	m^3	gross (register) tonnage (expressed in units of $2.83 m^3$)
h	m	water depth; water level above undisturbed level;
h_{berth}	m	water depth at the berth location
h_f	m	freeboard
h_{gd}	m	guaranteed depth (with respect to a specified reference level)
h_{net}	m	remaining safety margin or net under keel clearance
h_{over}	m	overdepth
h_s	m	average height of the cargo in the storage or CFS
h_T	m	tidal elevation above reference level, below which no entrance is allowed
H_s	m	significant wave height
i	-	inflation rate

Symbols

k	m	radius of gyration of the ships mass around the c.g.
k	-	blockage coefficient ($=A_s / A_{ch}$)
k_p	kN/m	pile stiffness
L	m	wave length
L_b	m	required berthing quay length for resting of vessels
L_B	m	length of basin or slip
L_{pp}	m	length between perpendiculars
L_{OA}	m	length over all
L_q	m	quay length
L_s	m	ship length; main vessel length
L_{st}	m	stopping distance
M	t	mass of the ship in tonnes
M	kNm	moment
m_b, m_s	-	occupancy rate of berth, respectively storage
m_c	-	acceptable average occupancy rate
n	-	number of berths
∇	m^3	water displacement
$N_{20'}$	-	number of TEU's
$N_{40'}$	-	number of FEU's
N_c	-	number of container movements per year per type of stack in TEU's
N_{cb}	-	number of cranes per berth
n_{dc}	day	number of days comprising a fishing cycle
n_{dr}	day	number of resting days in a fishing cycle
n_{du}	day	number of unloading days in a fishing cycle
n_{hd}	-	number of unloading hours in a day
n_{hy}	-	number of operational hours per year
N_{gs}	-	number of gangs per ship
NRT	m^3	net (register) tonnage (expressed in units of $2.83 m^3$)
N_s	-	number of ships
N_{sa}	-	number of vessels abreast
N_{sr}	-	number of vessels at rest
N_{sy}	-	number of ship calls per year
P	W	power

P	t/hr	(un)loading productivity per handling entity (crane, gang, pumps)
P_0	currency	initial price level
P_1	currency	new price level
Q_0	-	initial quantity
Q_1	-	new quantity
r	m	distance between c.g. of the ship and the point of first contact during berthing
r	-	real discount rate
r_{st}	-	ratio of average stacking height and nominal (0.6 to 0.9)
R	-	nominal discount rate
s	m	squat
s	m	space between vessels
S(t)		quantity of containers still on terminal; total number unloaded containers
s_{max}	m	maximum sinkage (fore or aft) due to squat and trim
t	tonne or metric ton	load
t_d	day	dwelt time
t_{dmax}	day	maximum dwelt time (e.g. time within which 98% of containers have left the terminal)
T_a	s	apparent wave period
T_B	t	total bollard pull
T_n	s	natural periods of oscillation (nth harmonic)
T_p	s	peak wave period
U, u, V	m/s	water velocity; current velocity
u_b	m/s	velocity near the bed
v	m/s	approach velocity of ship's centre of gravity at time of impact
V	m ³	contents of 1 TEU container
V_c	m/s	average current velocity over the underwater part of the hull
V_d	m ³ /yr	average annual volume of resiltation
V_{eff}	m/s	ship speed with respect to channel bottom (design entrance speed)
V_{min}	m/s	minimum ship speed for rudder control

Symbols

V_s	m/s or knots	sailing speed
V_{wv}	m/s	wind velocity
V_{wd}	m/s	transverse speed of ship as a result of wind drift
w	kg/m ³	specific weight of seawater
W	m	average width of canal; width
W_a	m	additional width
W_b	m	bank clearance
W_{bm}	m	basic width
W_{eff}	m	channel width in unrestricted shallow water
W_p	m	separation distance
$W_{shelter}$	m	sheltering width in the wave direction
y_p	m	pile deflection
y_f	m	fender compression
z	m	vertical distance from undisturbed water level (up is positive)
z	m	vertical motion amplitude due to wave response
α	deg.	angle between wave direction and ship axis
α_{axis}	deg.	angle between current and channel axis
β	deg.	drift angle
γ	deg.	angle
Δ	-	relative density ($=(\rho_s - \rho_w) / \rho_w$)
Δ	t	ship displacement in tons
Δ_{CS}		currency change in consumer surplus
θ	deg.	angle interference peaks
θ_c, θ_w	deg.	angle between current and ship axis, respectively between wind and ship axis
ρ_{air}	kg/m ³	density of air
ρ_{cargo}	kg/m ³	density of the cargo as stowed in the ship or stacked in the storage
ρ_w	kg/m ³	density of water

Chapter 1

Introduction

By nature port planning is a multidisciplinary activity. It involves expertise in the field of transport economics, shipping, nautical matters, safety and logistics. But also knowledge of waves and currents, sediment transport and coastal morphology, dredging and land reclamation, and design of breakwaters and quays. Hence port planning is teamwork. But within this team the port planner plays a central role in developing the concepts and obtaining the required expertise at the right time. Most port planners are civil engineers with hydraulic engineering training and experience. But they need to have two important qualities in addition to that:

- i. a basic understanding of the other disciplines involved
- ii. creativity

The first quality is needed to direct the work done by these experts and to integrate the results into a balanced design of the port lay-out. The integration process itself is the creative part of the work: after having determined the basic dimensions of approach channel and turning basins, of quays and terminals and of the corridors for hinterland connections, there are often many ways to physically arrange them into a port lay-out. Here the second quality mentioned above plays a crucial role in developing the right one.

The first part of this book (Chapter 1 through 6) is aimed at providing the basic elements to perform this planning process. In Chapter 7 the detailed planning of container terminals is treated, including the logistic process. Further attention is paid to design aspects, typical for such terminals. The objective is to provide the basis for an all-round port engineer, somebody who can participate in the design of any given type of port or terminal.

Chapters 8-14 present the planning aspects of other types of terminals.

Chapter 2

Maritime Transport

2.1 Introduction

Maritime transport is (in terms of tonne kilometres) the most important of the 6 transport modes, the other five being inland water transport, road, rail and air transport and transport by pipeline. It is relevant to make the distinction between intercontinental maritime transport and that within a continent, because of the different competitive position. For the intercontinental shipping air transport is the only alternative, but not really a competitor because of the great difference in freight rates (see Table 2.1). Broadly speaking only passengers and high-value goods are carried by plane and this share of the market for transportation is well defined.

Table 2.1 Freight rates across the Atlantic Ocean

Transport mode	Door-to-door time (days)	Freight rate (US\$/kg)
Priority air	2-3	4.0 - 5.6
Standard air	4-7	2.5 - 3.5
Direct ocean	14-28	0.25 - 0.40

Maritime transport within a continent has many competitors, road transport being the most important one. Again the air transport mode is quite distinct from the others in terms of freight rate. But maritime transport, road, rail and inland water transport are in the same cost range and therefore in fierce competition. Maritime transport used to be at a disadvantage compared with roads for two reasons:

- i. it often needs additional transport between seaport and final destination. This creates two extra links in the chain, which increases costs, time and unreliability (see Figure 2.1)
- ii. ports presented an uncertain element, due to the conventional custom procedures and the frequent labour strikes, which could cripple transport for weeks.

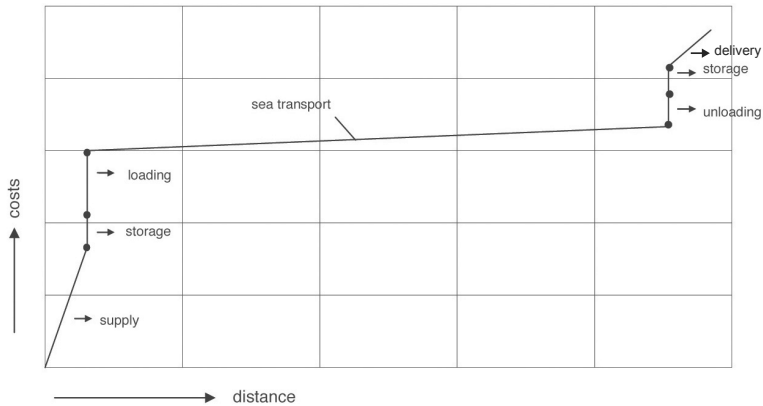

Figure 2.1 Costs elements in a transport chain

Both the intercontinental and the continental maritime transport volumes are increasing. The former due to the steady growth of world trade, the latter also because sea transport is becoming more attractive. Customs procedures become shorter by modern technology such as Electronic Data Interchange (EDI) and Smart Card. The reliability of the connections between sea and land transport becomes better by fixed routes and schedules and in many parts of the world the ports become more 'business oriented' and provide faster and more reliable services.

And last but not least there is an added environmental advantage as the CO₂ emissions are relatively small as compared to other transport modes. Approximate values for CO₂ emission per tonne.km are:

Air transport	550 g
Road transport	80 g
Rail transport	20 g
Maritime transport	3 g

Containerisation in particular represents a major factor in the growth of cargo volume and therefore in the increase of port capacity required. The average growth rate of container terminal throughput between 2000 and 2010 was around 10% per year. This figure comprises the absolute growth of (general) cargo volume, but also the shift of conventional general cargo to containerised cargo. It means new terminal capacity, cranes and other equipment. This is illustrative for the present trend in port development world-wide: quite a number of ports are reaching saturation and are being expanded. Examples nearby are Rotterdam (Maasvlakte 2), Antwerp and Le Havre. The upturn is caused by the impressive economic growth in Asia, in particular in China, where the port of Shanghai at the end of 2004 took over the position of largest port in the world from Rotterdam. The 2008-2012 global economic crisis hardly caused any reduction of cargo transports, but the slow-down of China's economic growth since then has affected these. With the likely shift of production of goods back to where the consumers live it is expected that in the coming decades the large East-West container volumes will further reduce. On the other hand North-South volumes and regional trades (Short-Sea shipping) are expected to increase.

Port development depends on the development of maritime transport, both in terms of volumes per commodity and in relation to types and sizes of vessels. For port planning a good understanding of these developments is mandatory. The following sections present data on ship design and cargo handling (as far as relevant for port planning) and some trends.

2.2 Specific Data of Merchant Ships

2.2.1 Transport Capacity

The tonnage of a ship is an indication of the carrying capacity in terms of the amount of cargo she can transport. Unfortunately, depending on the type of vessel, the country of origin, or the purpose for which the tonnage is used (for instance for harbour dues), there exist several ways to express tonnages. The most important ones are:

GRT	Gross Register Tonnage
NRT	Net Register Tonnage
DWT	Deadweight Tonnage

The relations between these three parameters are not fixed unconditionally: they depend mainly on the type of vessel concerned. However, within certain limits, the following relations can serve as a first approximation (see also Fig. 2.2):

General cargo ships:	DWT \approx 1.5	GRT \approx 2.5	NRT
Very large crude oil carriers:	DWT \approx 2.0	GRT \approx 2.6	NRT

The definitions of the tonnages are as follows:

GRT is the total volume of all permanently enclosed space above and below decks, with certain exceptions, such as the wheelhouse, chart room, radio room and other specific space above deck, expressed in tons, in which one ton is equal to $100 \text{ ft}^3 = 2.83 \text{ m}^3$. GRT is normally used as the basis for calculating port dues.

NRT is the total of all space destined for cargo, expressed in units of 2.83 m^3 . The NRT is equal to the GRT minus the crew's accommodation, workshops, engine room etc.

DWT is the difference between loaded and light displacement, in which:

- Loaded displacement is the ship's mass when fully loaded, so including hull, engines, cargo, crew etc. Fully loaded means that the ship sinks into the water down to her summer draught line (see Plimsoll Mark).
- Light displacement is the mass of the ship's hull, engines, spares, and all other items necessary for normal working performance.

In other words, the DWT gives the mass of the cargo, fuel, crew, passengers, fresh water, victuals, etc. expressed in metric tonnes.

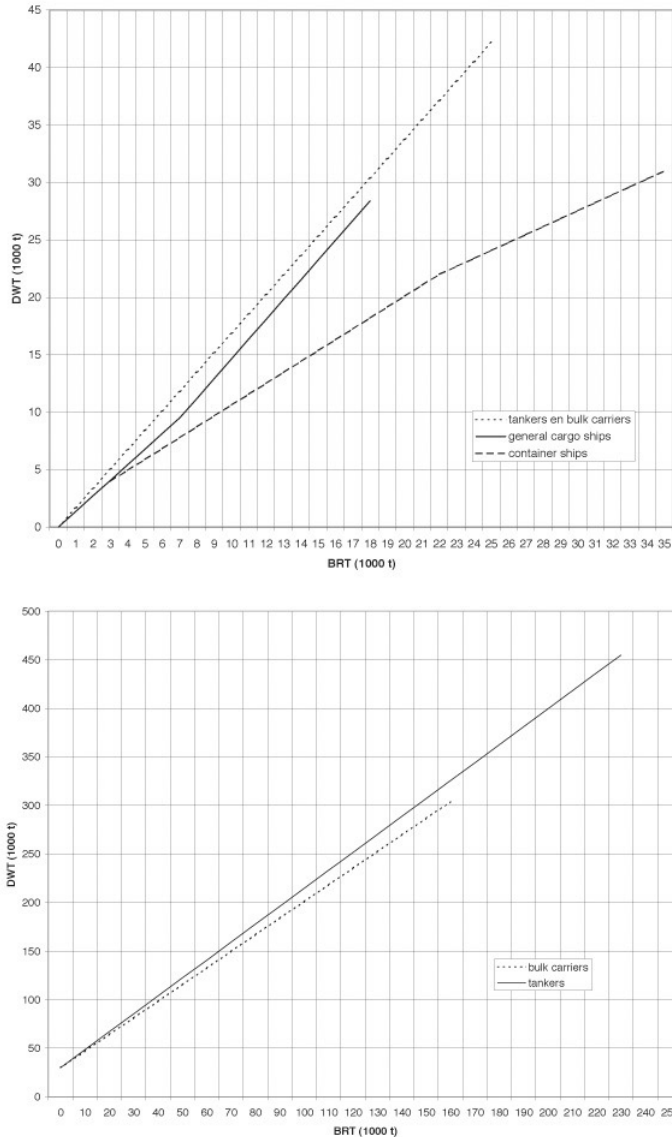

Figure 2.2 GRT versus DWT

The following units are used (using the non-SI unit of kg)

- Tonne or metric ton (t = 1000 kg)
- English or long ton (1016 kg)
- Short ton (907 kg)

Port- or shipping tons are used to determine sea transport charges. A port or shipping ton is equal to 1 m³ and equal to 1 t when the specific weight of cargo is bigger than 1 t/m³.

For some specialised ships the carrying capacity is not only expressed in GRT, NRT or DWT, but also in other units, typical for the type of vessel concerned. Examples of this are:

2 Maritime Transport

TEU This unit is normally used to express the capacity for container storage on board of a ship. TEU stands for Twenty Foot Equivalent Unit, which is the space taken by a standard container of the following dimensions:

Length = 20 feet = 6.03 m,
Height = 8 feet = 2.44 m, and
Width = 8 feet = 2.44 m, thus
Volume = $6.03 \times 2.44 \times 2.44 = 35.9 \text{ m}^3$.

2.2.2 Vertical Dimensions

The *draught* D of a vessel is the maximum distance in meters between the waterline and the keel of the ship (Figure 2.3). Displacement tonnages are calculated in respect of the draught D and the stationary *freeboard* h , the distance between waterline and the deckline which is indicated on the ship's side.

The maximum draught line is indicated by the so-called Plimsoll Mark. This mark is composed of a circle and a horizontal bar with two letters on either side of the circle. The letters stand for the classification society of the Plimsoll Mark, that issues binding conditions for sizes and quality of materials to be used, tests to be carried out, etc. Without "classification" a ship is virtually non-insurable.

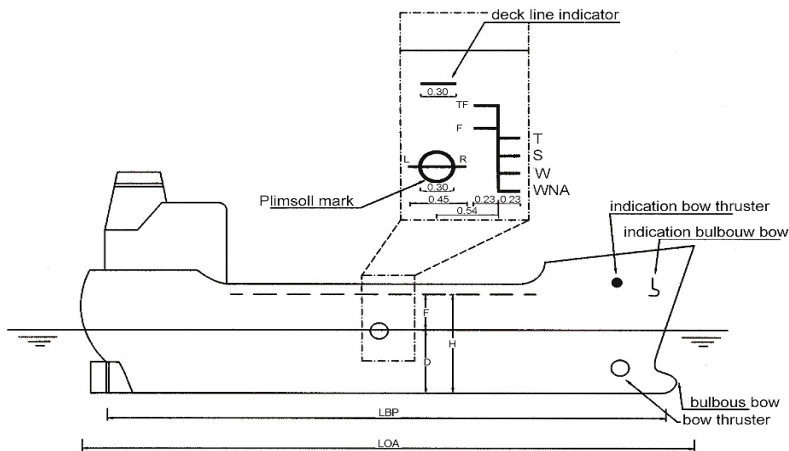

Figure 2.3 Ship dimensions

Most common letters are:

- LR: Lloyds Register (England)
- BV: Bureau Veritas (France), and
- AB: American Bureau of Shipping (USA).

The draught of a vessel is related to the density of the water in which she is sailing (uplifting force). Since the density does not have a constant value over the year, and also differs with *longitude* and *latitude* (a ship sinks deeper into the water in summer around the equator than in winter on the North Atlantic), another indicator is to be found at the right side of the Plimsoll Mark. This indicates the maximum permissible draught under various conditions, such as:

TF	=	Tropical Fresh Water
F	=	Fresh Water
T	=	Tropical Salt Water
S	=	Summer Salt Water
W	=	Winter Salt Water, and
WNA	=	Winter Salt Water on the North Atlantic

A certain safety margin is also incorporated in the markings of maximum permissible draught. The draught of a vessel is indicated by numbers that are painted on both sides of the ships hull, usually at the bow, amidships, and at the stern. Often, these figures indicate the draught in decimeters

Above we have mentioned draught as the average value over the ship's length, when the ship is completely horizontal in the water. When a ship is tilting in longitudinal direction this is called "trim". Static trim is caused by uneven loading (which should be avoided). Dynamic trim can be the result of the ship's forward speed (see Section 5.2.2). A sideways inclination of the ship, the "list", may also be caused by uneven loading, but always occurs when the ship turns. Both trim and list add to the total draught.

2.2.3 Horizontal Dimensions

Length

The length of a vessel can be expressed in two different ways:

L_{PP} : Length Between Perpendiculars, and

L_{OA} : Length Over All

Both lengths are indicated in Figure 2.3. The definitions are as follows:

L_{PP} : is the horizontal distance in meters between the points of intersection of the ship's bow and the summer salt water line when fully loaded and the vertical line through the axis of the rudder of the ship.

L_{OA} : is the horizontal distance between two vertical lines; one tangent to the ship's bow and one to the ship's stern.

For dimensioning harbour basins and berths normally L_{OA} is normative. Unless specifically mentioned L_{OA} is used in this book (written as L_s).

Beam

The beam or breadth B_s , is the maximum distance in meters between the two sides of the ship.

2.2.4 Other Relevant Data

Without going into the details of ship design some information is relevant for the manoeuvrability and hence for the design of approach channels and water areas inside a port.

Engine power and number/type of thrusters are decisive in this respect. Extremes are on one hand large bulk carriers and (high speed) ferries on the other. Notwithstanding their size some of the large ore carriers and crude oil tankers are equipped with only one screw or propeller and have a relatively low engine power. They are designed for long distance, low speed transportation and will require assistance by 3 or 4 tugs during arrival and departure in the ports.

Ferries are generally overpowered and are provided with 2 or more propellers and often 1 bow thruster (Figure 2.4). High-speed ferries have water jets instead of propellers.

Many ships built today are equipped with one or more thrusters, either at the bow or at the stern or both. For safety reasons the presence of a bow thruster is indicated on the bow above the waterline.

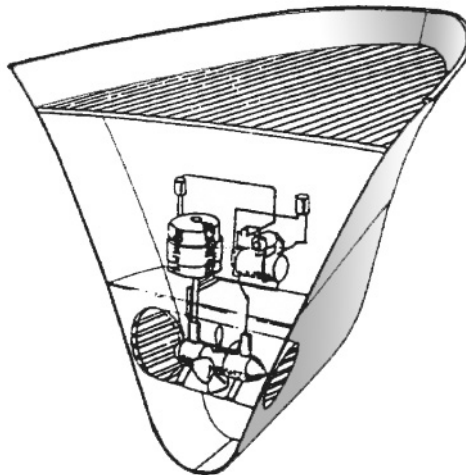

Figure 2.4 Kamewa bow thruster

Vessel speed is expressed in *knots*. One knot is equal to one nautical mile (or 1852 meter) per hour, equivalent to 0.514 m/s. The maximum speed of bulk carriers and VLCC's amounts to 18 knots. Ferries are designed for maximum speeds of about 24 knots and empty high-speed ferries have maximum speeds of about 40 knots, while the service speed (full load) amounts to 35 knots.

2.3 Commodities and types of vessels

2.3.1 Introduction

Cargo flows can be classified according to type of cargo and according to the form in which it is transported (dry bulk, containers, etc.).

The first classification follows the internationally agreed division into 10 main groups of cargo referred to as NSTR (Nomenclature uniforme des marchandises pour les Statistiques de Transport, Révisé). These main groups are:

- a. Agricultural products and livestock
- b. Other food products and fodder
- c. Solid mineral fuels (e.g. coals, cokes etc)
- d. Oil and oil products, incl. fuel gas
- e. Iron ore and metal scrap
- f. Iron, steel and non-ferro metals
- g. Raw minerals; construction materials
- h. Fertilisers
- i. Chemical products
- j. Vehicles, machinery and other goods

Standardization of these categories allows to use the statistics of different countries and individual ports to quantify international flows of cargo and to forecast future developments. As explained in Chapter 4 any port planning study starts with such forecasts dealing with above main groups of cargo, but often going into subcategories (e.g. fruits as a subcategory of Agricultural products).

For the subsequent physical planning of terminals within a port master plan, the cargo characteristics are important insofar as they affect the location and possible combination of different cargo flows within the port area. These considerations will be treated in the chapters on terminal design, but a simple example may illustrate such effects: Categories 3 and 8 include hazardous goods and are therefore subject to safety requirements regarding the location of such terminals with respect to other terminals and surrounding areas.

The second classification of cargo is important for the actual design of terminals. With respect to the form in which cargo is transported the following division is made:

- A. Dry bulk
- B. Liquid bulk
- C. Containers
- D. Roll-on/Roll-off
- E. Other

The last category "Other" is almost identical to conventional general cargo, which includes the *break-bulk cargo* (many pieces of various dimensions and weights), *mass-break-bulk* or *neo-bulk* (many pieces of mostly uniform size and sometimes uniform weight) and *bagged goods*.

In the next section these categories of cargo types will be discussed as well as the different types of vessels in which they are carried. Furthermore, special types of vessels will be treated, such as ferries and cruise vessels for passenger transport. For further reading on shipping business reference is made to the IHE lecture notes on Merchant Shipping (Kruk and De Heer, 2005). Many of the examples of different types of ships shown in the subsequent pages have been taken from 'Shipping' (Wijnolst et al, 1996). And the graphs (in Figures 2.32 - 2.26) with typical dimensions of General Cargo-, container-, dry bulk- and oil tankers respectively have been updated on the basis of the study 'Ship dimensions in 2020' (Lloyd's Register M.S., 1998).

2.3.2 Break-bulk or Conventional General Cargo

Break-bulk is defined as all kinds of boxes, crates, bags, sacks, drums, machine parts, refrigerated cargo as fruit, meat etc. Generally the break-bulk cargo will be transported by one of the three types of break-bulk ships, i.e. conventional general cargo ships, multipurpose ships and refrigerated ships.

General cargo ship

A general cargo ship may carry all kinds of break-bulk cargo. The weight of each piece of cargo (a *lift*) is limited by the maximum lifting capacity of the shore based crane or the ship's derrick. Each piece of cargo is handled separately or sometimes as an assembly of some smaller items. The cassette system is relatively new, and designed for efficient handling of rolls of paper.

Table 2.2 Categories of break-bulk

Categories of break-bulk	Shape or packing	Cargo handling method
Bagged goods Normal Break bulk Neo Bulk	Undefined shape Crates, boxes, drums Steel plates, bars and wire, lumber and timber, paper	Ropes, on pallets Ropes, hooks, pallets Ropes and hooks, cassettes

The general cargo ship is the archetype of cargo ship. All new, specialised vessels originate from the general cargo ship.

The capacity of the conventional general cargo ship ranges from 5000 to 25000 t. It has four to five holds (space for cargo storage below deck) and usually one or two "tween" decks, which run all along the ship. This makes it possible to stow cargo in such a way, that it can be distributed evenly over the ship's length and/or to unload a certain quantity of cargo in a certain port without moving other cargo as well.

The older general cargo ships can easily be identified by the many derricks (ship's cranes) placed on deck. These are arranged in such a way, that each hold can be served by at least two derricks. The older designs of general cargo ships show the wheelhouse amidships, but more recent designs show a tendency to place it three-quarters aft or aft.

The draught of the vessel is usually small, ranging from 7.5 to approximately 10 meters, which enables the ship to call at most ports of the world, even the smaller ones. An example of a general cargo ship is shown in Figure 2.5.

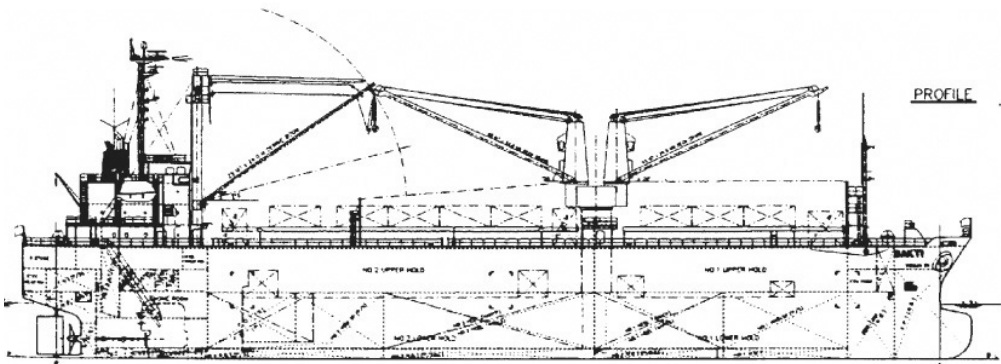

Length Over All:	113.22 m
Length Between Perpendiculars:	105.40 m
Breadth:	19.60 m
Draught:	7.29 m
Deadweight:	8,739 t
Maximum speed:	13.30 knots

Figure 2.5 General Cargo ship 'Sakti'

Over the recent years, when more and more emphasis was put on the reduction of the ship's turnaround time, some new developments took place in design, as well as in cargo handling methods, of the general cargo ship:

- a. The openings of the holds (hatches) became wider and were placed in one vertical line to ease the vertical movement of cargo. It even became possible to lower small equipment for cargo handling, such as forklift trucks, into the holds. The aim to achieve unobstructed movements of cargo was also one of the reasons why nowadays most wheelhouses of general cargo ships are placed aft instead of amidships.
- b. Horizontal cargo handling through side loading ports (see Figure 2.6)
- c. The development of the Unit Load Concept (ULC), from pallets to other forms of unitization such as cassettes for paper.

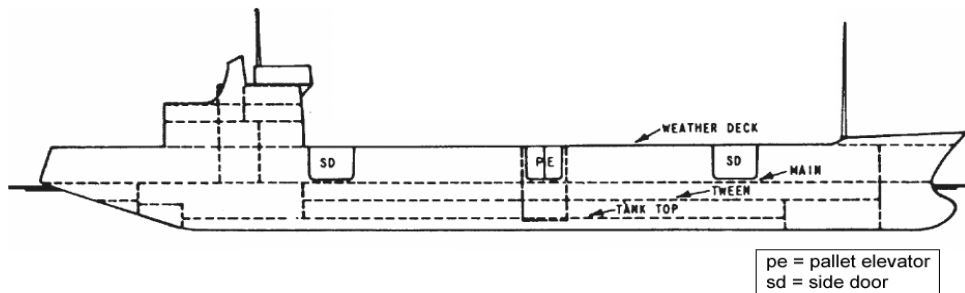

Figure 2.6 Horizontal cargo handling through side loading doors

Multipurpose ship

The multipurpose ship, in fact a general cargo ship, is capable of transporting almost any piece of cargo, ranging from a small box to a container or even a truck. The designs made in recent years also show a limited capacity to carry bulk cargo, either liquid (oil, chemical products), or dry bulk (grain, ore, etc.) and refrigerated cargo. Especially directed to serve less developed ports, the ship has heavy lifting equipment on deck. The ship can easily be defined by:

- a. The robust shape and heavy lift deck equipment.
- b. The hatch covers that have been constructed in such a way that they can withstand the load of heavy pieces of cargo or containers placed on it.
- c. Bow thrusters and bulbous bow.
- d. Side loading doors for horizontal cargo handling.

An example of a multipurpose ship is shown in Figure 2.7.

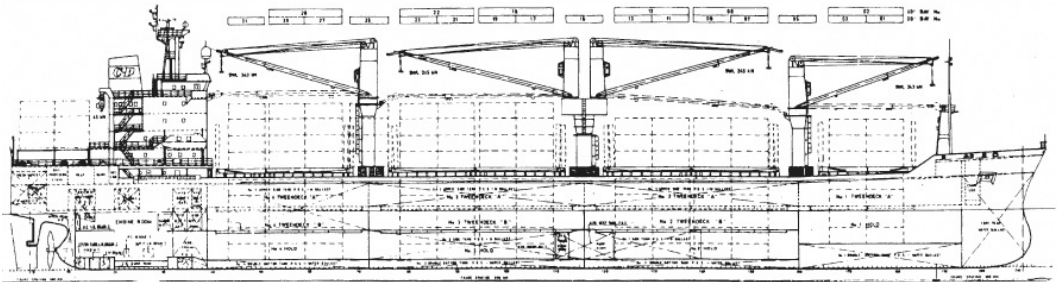

Length Over All:	169.69 m
Length Between Perpendiculars:	162.50 m
Breadth:	27.50 m
Draught:	9.32 m
Deadweight:	22,271 t
Maximum speed:	16.20 knots

Figure 2.7 Multipurpose ship 'Taixing'

Refrigerated general cargo ship (reefer)

This general cargo ship is solely used for the transportation of fruit, meat, or other perishable commodities, which are kept on board at temperatures between -30°C and 12°C . The reefer distinguishes herself from the conventional general cargo ship by the following features:

- the ship is usually painted white

2 Maritime Transport

- her speed is higher; usually from 18-25 knots
- she looks quite elegant and fast; the appearance is streamlined

In recent years, container ships are provided with slots for refrigerated containers. These do not supplant the specialized ships such as a reefer, of which an example is given in Figure 2.8.

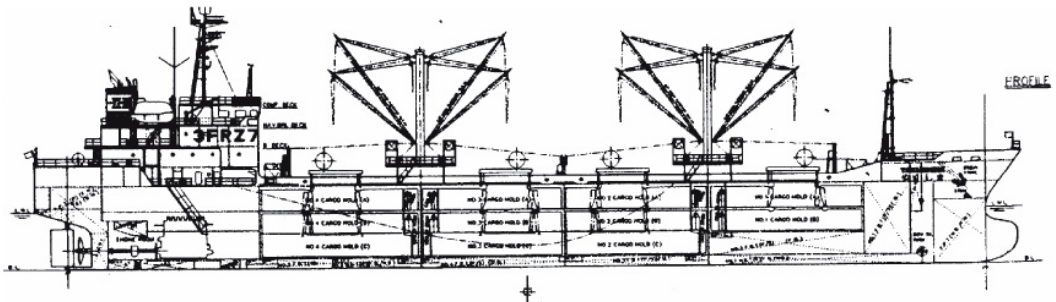

Length Over All:	120.12 m
Length Between Perpendiculars:	111.60 m
Breadth:	16.80 m
Draught:	7.00 m
Deadweight:	5,563 t
Maximum speed:	18.87 knots

Figure 2.8 Refrigerated cargo ship 'Yakushima'

2.3.3 Container Vessels

Notwithstanding the introduction of ULC in the handling of break-bulk cargo the turnaround times of general cargo vessels remained high. After World War II world trade increased rapidly and with it the sea transportation, leading to serious congestion in the ports and long waiting times.

The container had been introduced in the fifties as standard size box for the transport of cargo by truck and rail across the USA. Its use in sea transport seemed a logic step in view of the abovementioned problems, but received initially severe resistance, in particular from the powerful unions of dockworkers. It did reduce the turnaround times and waiting times in ports substantially. Initially limited to coastal shipping along the US West and East Coast, the first SeaLand containers arrived in Rotterdam in 1966. Over the past 50 years container shipping has spread across the globe, taking over a major share of the general cargo trade.

The "first generation" container ships were general cargo and bulk vessels, adapted to carry containers on the deck. Since then several classes of container ships have been built with increasing dimensions and capacities (see Table 2.3).

Table 2.3 Container vessel development (source: Ashar et al, 2012)

Class	TEU capacity	DWT (average)	L (m)	B (m)	D (m)
Early container ships	500-800	20,000	137-175	17-20	9-10
Fully Cellular	1000-2500	35,000	215-250	20-32	11-12
Panamax (1980-)	3000-4500	60,000	250-290	32.3	12.5
Post Panamax (1988-)	4500-8000	80,000	285-310	38-42	12.5-16
New Panamax (2014-)	12,500	120,000	366	49.0	15.2
Post New Panamax	> 14,000	156,000	400	56.0	16
Ultra Large Container Vessel (ULCV)	> 18,000	165,000	400	59.0	15

The following points should be noted:

- i. The 2nd and subsequent generation ships were designed to carry only containers, the so-called **Full or Cellular Container Ships**. The boxes were placed below deck in the bays, divided into cells with vertical guiding rails along which the containers are lowered into and hoisted out of the bay. On deck the containers are arranged in rows parallel to the ship's axis and secured by lashing systems.
- ii. In 1980 the first **Panamax** vessels came into operation, having a beam limited to 32.3 m, allowing them to pass the original locks in the Panama Canal. Traffic between the East- and West coast of the USA was still of high economic (and

military strategic) importance.

- iii. In the eighties the Asia-Westbound and Pacific Trades became more dominant, and shipping lines made the step to **Post Panamax**, accepting that these vessels could not pass the Panama Canal. In the next decade these ships were further scaled up to 8000 TEU, with dimensions up to 300x42x15.2 m (also called Super Post Panamax). It is pointed out that this growth does not only require larger depth, but also leads to higher cranes with longer booms.
- iv. In 2006 another jump was made by the addition of the Emma Maersk to the fleet of this shipping company. This ship was officially listed having a capacity of 12,500 TEU, but from its dimensions (of which the draught is estimated) it can be deduced to be at or above 14,000 TEU. Referring to the dimensions of the new Panama locks, this ship class is now called **Post New Panamax**.
- v. In 2013 Maersk Lines received the first of 20 new ships with a capacity of 18,000 TEU, dimensions $L_s = 400$ m, $B_s = 58$ m and $D = 15.0$ m. Subsequently other shipping lines ordered such **Ultra Large Container Vessels**, the largest of which so far was delivered in March 2017, called MOL Triumph (20,000 TEU).
- vi. With the opening of the new locks in the Panama Canal in 2014, the ships that can just pass them are categorized as **New Panamax**. It should be noted that for the new locks the ship length is the limiting factor, while for the existing locks this was the beam.

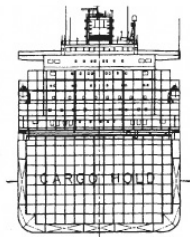
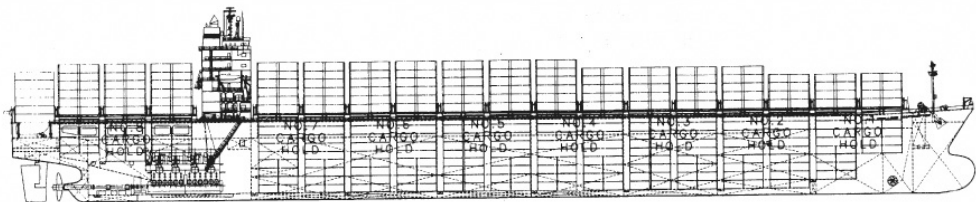
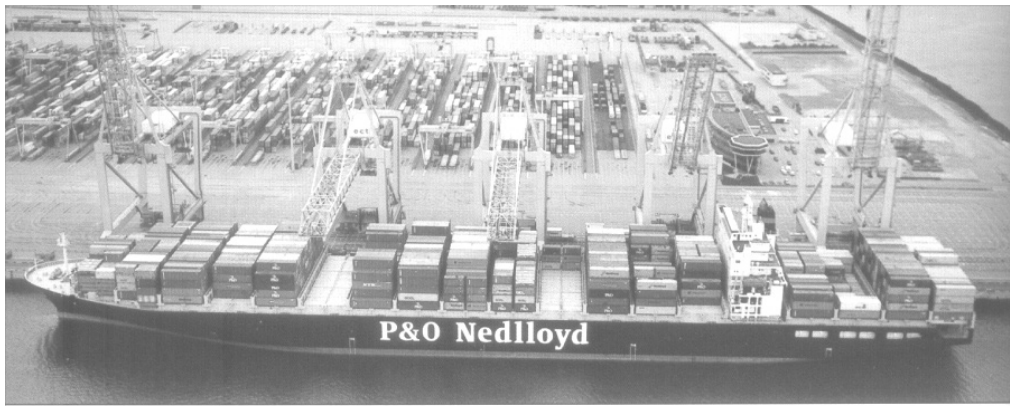

Length Over All:	299.00 m
Length Between Perpendiculars:	283.80 m
Breadth:	42.80 m
Draught:	13.50 m
Deadweight:	83,826 t
Maximum speed:	24.50 knots

Figure 2.9 Jumbo container ship 'P&O Nedlloyd Southampton'

Whether this unequal growth of ship size will continue in the future remains to be seen. The new-building of quite a number of ULCV's by all major shipping lines in combination with a sharp reduction of the growth of China's export volumes has led to a considerable overcapacity. And it is expected that in the long term the cargo flows between Asia, Europe and Northern America will further decline. A parallel may be found in the way in the 70ties of last century the growth of crude oil tankers leveled off.

Another trend in container ship design was the introduction, by former Nedlloyd (now Maersk), of hatch-coverless vessels with full height cell guides (including 4 tiers high above the board of the ship).

The time involved in lifting off the hatch covers, removing the lashings and placing both back (roughly two hours for the larger ships) would be eliminated. A number of ships of this design has been built (Figure 2.10), but in practice the reduction of service time in port appears to be less than anticipated. Some negative effects of the design, e.g. overcoming seawater in the holds, made that the concept did not get follow-up.

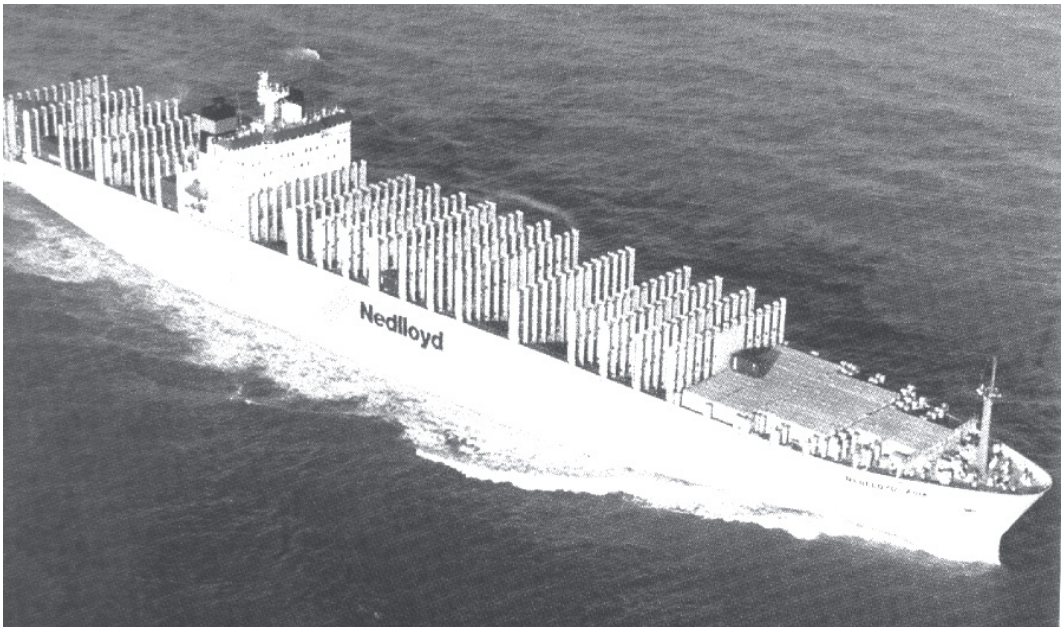

Figure 2.10 Container ship without hatch covers

In the early period of containerization some ships carried their own equipment to handle the boxes. This is the shiptainer, a gantry crane on board of the vessel, able to run from forward to aft on rails on the deck. In ship new-building this is no longer practice, mainly because most ports have shore based cranes (ship-to-shore cranes or portainers, see Figure 2.11).

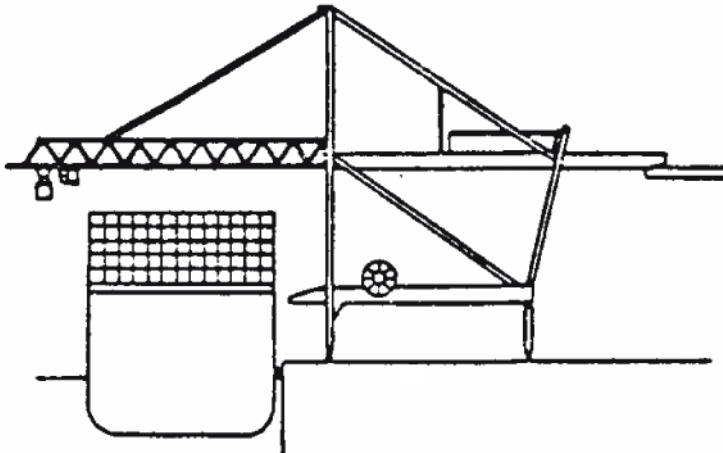

Figure 2.11 A Ship-to-Shore crane or portainer

2.3.4 Ro/Ro Vessels

Another type of unitised cargo, which was developed in road transport, is the trailer. They have two important differences with the sea containers: they are not fit to carry the weight of other containers and they can not be lifted (no corner castings). While sea containers are

sometimes referred to as Lo/Lo cargo (lift on / lift off), the transport of trailers and trucks is known as Ro/Ro (roll on / roll off). In most cases the chassis are carried overseas without the trucks. Movement onto and from the ship is done by special yard equipment. At some terminals the entire truck-trailer combination is taken aboard.

The Ro/Ro ships are therefore comparable with ferries, they must have a facility to drive the cargo on and off the ship. Contrary to the ferry, which normally sails on short routes only, this type of ship can serve on the longer routes.

The first types of Ro/Ro ships usually had the ramp at the stern of the ship. When at sea it was pulled up into a vertical position and in port it was lowered onto the quay. The disadvantage of this type of ramp is, that a special place in the port or even a special berth construction is necessary (see Figure 2.12). The manoeuvring with long trailers may be difficult, since much space is required which is not always available. The problems with high tide differences were solved by use of a pontoon between ship and quay.

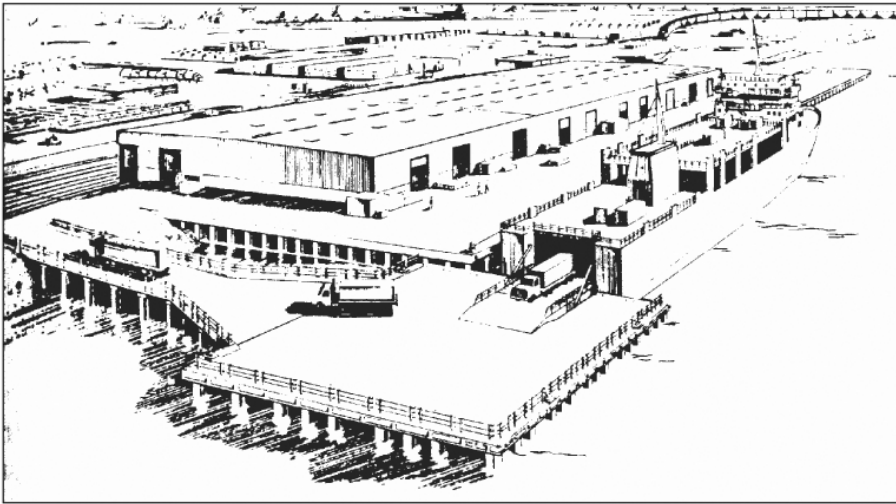

Figure 2.12 Special berth structure

To attain more flexibility in the allocation of a berth in a port, Ro/Ro ships were later on provided with a quarter ramp, which makes an angle with the axis of the ship and enables the ship to berth at any part of a straight quay (see Figure 2.13).

The carrying capacity of Ro/Ro ships is usually expressed in lane length, being the total length of the lanes in which the trailers are placed on the different decks of the ship (standard width of 2.50 m). The latest types of Ro/Ro ships have a total lane length of about 6000 m. An example of a Ro/Ro ship with both quarter and stern ramp is given in Figure 2.14.

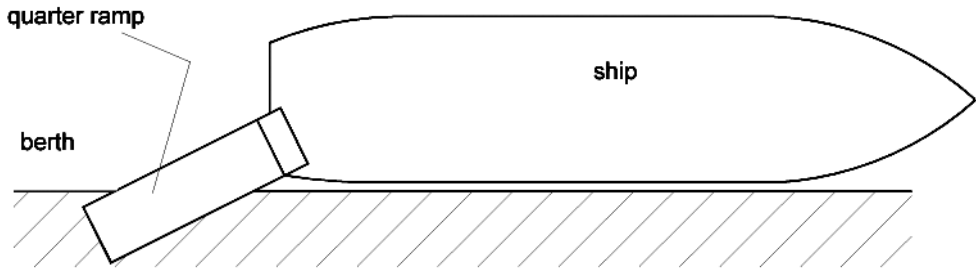
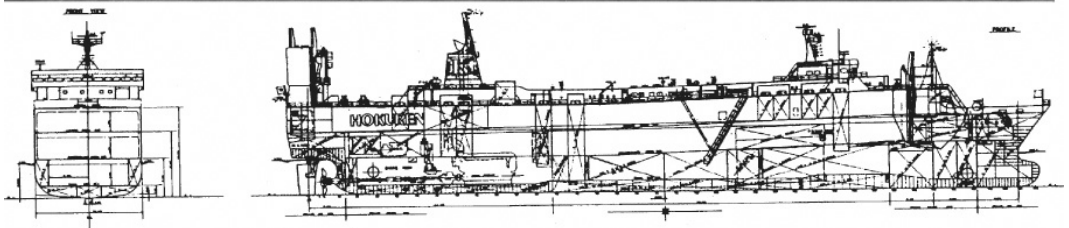

Figure 2.13 Quarter ramp

Various ship designs exist, combining Ro/Ro facilities with place for sea containers, the latter usually on the deck. An example of such a Ro/Ro-container ship is given in Figure 2.15.



Length Over All:	153.62 m
Length Between Perpendiculars:	142.80 m
Breadth:	21.40 m
Draught:	6.975 m
Deadweight:	5,445 t
Maximum speed:	24.971 knots

Figure 2.14 Ro/Ro ship 'No. 2 Hokuren Maru'

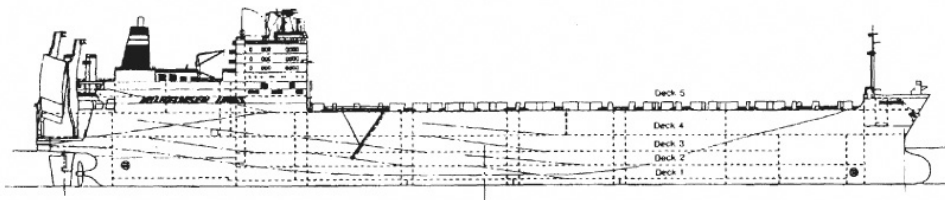

Length Over All:	264.60 m
Length Between Perpendiculars:	249.00 m
Breadth:	32.26 m
Draught:	11.75 m
Deadweight:	47,144 t
Maximum speed:	22.16 knots

Figure 2.15 Ro/Ro container ship 'Taronga'

2.3.5 Car Carriers and Other Special Vessels

Car carrier

These ships have been designed for the transportation of newly built motorcars from the producer to the consumer markets. Like Ro/Ro vessels they have ramps to the shore. In addition to the quarter ramp, these vessels often have one or more side ramps to speed up the loading and unloading process. Because the net load of motorcars is relatively low, these vessels have a small draught and a large freeboard, as shown in Figure 2.16. This implies that they are sensitive to wind and require substantial tug assistance while in port.

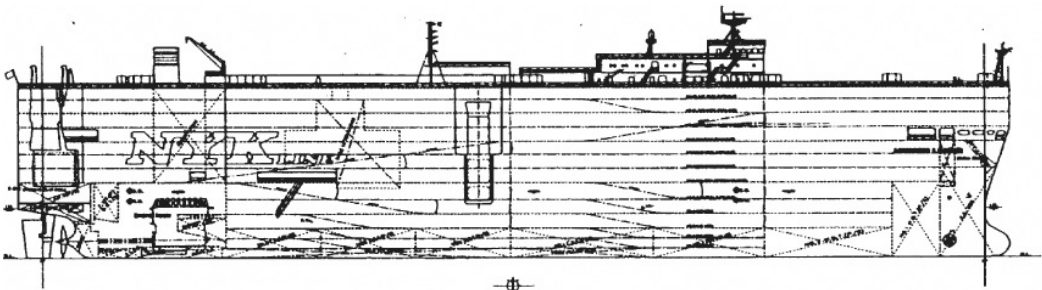

Length Over All:	199.93 m
Length Between Perpendiculars:	190.00 m
Breadth:	32.26 m
Draught:	10.00 m
Deadweight:	22,815 t
Maximum speed:	20.61 knots

Figure 2.16 Car carrier 'Aquarius Leader'

Lash ship

The lash (Lighter Aboard Ship) is an example of integration of sea and barge transport. The principle of the system is as follows:

1. The cargo is stowed into a floatable barge at the producer's premises.
2. The barges are pushed or towed to the place where the Lash ship is to arrive, where they are put in a barge parking area.
3. After the Lash ship has arrived, the barges for the port concerned are unloaded and the already parked barges are put on board of the Lash ship.
4. The unloaded barges are put together in a formation and pushed or towed to the

customer.



Figure 2.17 Lash ship 'Arcadia Forest'

This set-up is the application of an advanced door-to-door transport system, provided consumer and producer can both be reached by water. Within the system the barges become the means of transportation itself.

The *Lash ship* was still in use till 2007, for instance in the Waalhaven, Port of Rotterdam, where an area was reserved for the mooring of these vessels and the parking of barges. Yet there is no new building of Lash ships reported in recent years.

Heavy lift carrier

The *Heavy Lift Carrier (HLC)* is another specialised ship, designed to transport huge, heavy units of cargo, that cannot, or can hardly be transported by any other type of vessel. Cargo, carried by HLC's, may for instance be dredgers, assembly parts of factories or refineries, drilling platforms, container cranes, etc. The ship is characterised by the vast deck-space, on which the superstructure with the wheelhouse has been placed at one of the extremes (either at the bow or at the stern), to create as much deck place as possible. Another characteristic is the presence of the one or more heavy-duty cranes or derricks with capacities of up to 500 t or more. The cargo can be placed on deck either by the ship's own gear or by auxiliary equipment, such as a floating or shore based crane or can be put on board in the roll-on/roll-off fashion, provided the HLC is equipped with a ramp. The method of operation of some HLC's is such, that the cargo can also be put on board by floatation, because the ship is submersible (in the same manner as a floating dry-dock). See Figure 2.18 for an example of a heavy lift carrier.

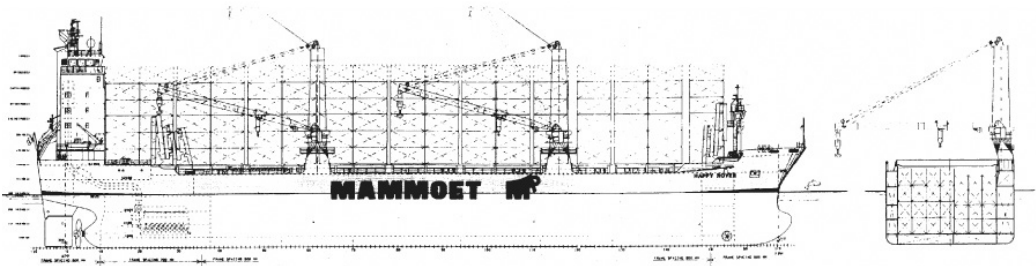

Length Over All:	138.00 m
Length Between Perpendiculars:	127.94 m
Breadth:	22.80 m
Draught:	9.50 m
Deadweight:	15,634 t
Maximum speed:	16.0 knots

Figure 2.18 Heavy lift carrier 'Happy river'

Cruise ships

Modern cruise ships are getting bigger, to such extent that existing terminals become inadequate, in terms of water depth or passenger facilities or both. Hence a lot of new cruise terminals are built, especially in the popular regions such as the Caribbean, the Mediterranean, etc. See Figure 2.19. The largest cruise ships under construction or in operation are of the Genesis class, measuring $L = 362$ m, $B = 47$ m and $D = 9-10$ m.

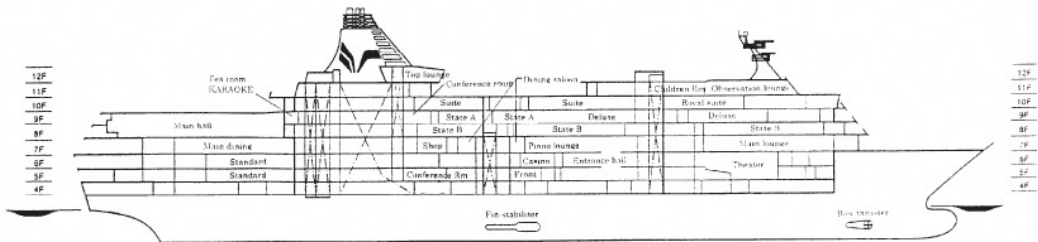

Length Over All:	183.40 m
Length Between Perpendiculars:	160.00 m
Breadth:	25.00 m
Draught:	6.50 m
Deadweight:	4,202 t
Maximum speed:	21.97 knots

Figure 2.19 Cruise ship 'Pacific Venus'

Ferry

The ferry vessel is also showing much development, both in terms of size and speed. As mentioned before, the ferry is employed on fixed routes over limited distances. They carry passengers, motor cars and trucks in different percentages, depending on the demands for each. In the past ferries used to transport entire train lengths, e.g. in connecting the rail lines on the Danish islands with the German and Swedish systems. Although these rail ferries still exist, they are not common in other parts of the world. The development of size is shown in Figure 2.20.



Length Over All: 99.00 m
Length Between Perpendiculars: 91.20 m
Breadth: 15.8 m
Draught: 3.22 m
Deadweight: 600 t
Maximum speed: 16.50 knots

Figure 2.20 Ferry 'Clansman'



Figure 2.21 HSS 1500

The need to reduce transit time (in order to remain competitive with other modes of transport) led to the development of high speed ferries. Although smaller types have been in use for decades, several very large ships came into service, such as the HSS1500 by Stena Line, in the Baltic and Irish Sea. With its cruising speed of 40 knots, it reduces the total transit time by 50% (see Figure 2.21). Negative aspects of these vessels are the high fuel consumption (and large emissions) and the large wash waves generated, which forces them to reduce speed when approaching the coast.

Fast Ship

In Section 2.1 it was mentioned that there is little competition between international shipping and air transport because of the clear market and freight rate differentiation. In recent years one exception has developed, i.e. the fast ocean going vessels, which are designed to transport certain high-value cargo which used to be carried by plane. In Japan the so-called *Techno Super Liner* is actually built and in operation, having a capacity of 150 TEU, and a maximum speed of 54 knots (see Figure 2.22).

For service between the US-East coast and Europe the Fast Ship concept has been developed in conjunction with a very special type of terminal, the *Alicon system*. This ship is designed to carry 1450 TEU at a cruising speed of about 40 knots, thus reducing the sailing time across the Atlantic Ocean from 8 to 3.5 days. The concept has not been realised, Here also the high fuel consumption and negative environmental impact may play a role.

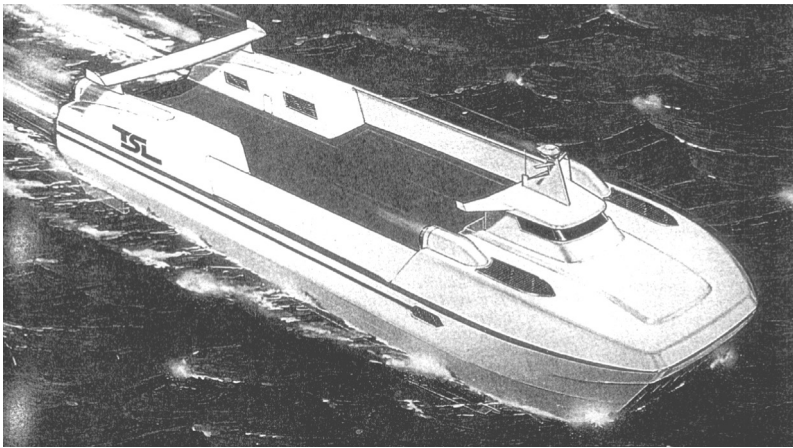

Figure 2.22 Artist impression Techno-Super liner (1993)

2.3.6 Bulk Cargo

Introduction

Bulk carriers usually carry large quantities of homogeneous, unpacked cargo, for instance liquids (oil, liquefied gas), chemical products (phosphate, fertilizer), cement, iron ore, coal, agro products (grain, rice etc.). Because of the homogeneous nature, this cargo can be handled in a more or less continuous way. The handling of bulk cargoes can be executed in various ways, such as pumping (liquids), sucking (cereals), slurring (mixture of dry bulk cargo and liquid, which can be transported by pipeline), or by a combination of grabs and a conveyor belt system (coal and ores).

Bulk carriers can also be subdivided in several types, which will be treated in the following sections. In principle two types exist, viz.

1. Liquid bulk carriers
2. Dry bulk carriers

Table 2.4 gives an overview of the different bulk carrier types:

Table 2.4 Bulk carrier types

Type	Cargo	DWT (1000 t)
1. Liquid bulk		
– Crude carrier	Crude oil	20-40
– Product tanker	Refined products	0.5-100
– Parcel tanker	Refined products, chemicals	0.5-40
– LNG tanker	Liquefied natural gas	60-90
– LPG tanker	Liquefied pressurized gas	0.5-70
2. Dry bulk	Ore, coal	100-400
	Chemical	5-70
	Agro products	0.5-10

In addition, bulk carriers are classified according to size as shown in Table 2.5.

Table 2.5 Size classes of bulk carriers

Class	DWT(1000 ton)
Handysize	20-30
Handymax	45
Panamax	79
Aframax	79-120
Suezmax	120-180
VLCC	200-300
ULCC	> 300

Liquid bulk carriers In 1992 MARPOL (International Convention for the Prevention of Pollution from Ships) was amended to make it mandatory for new-built tankers of 5000 dwt and more to have double hull. This happened in reaction to the Exxon Valdez oil spill in Alaska in 1989.

Given the average lifetime of ships of about 20 years most tankers sailing at present have a double hull.

Crude oil tanker (See Figure 2.23). Before the World War II, the consumption of oil was limited, because coal was the major source of energy in those days, and crude oil was therefore transported by small tankers. When after World War II the consumption started to rise (and soon to boom), the modern crude oil tankers appeared and soon grew larger and larger in size, trying to keep pace with the demands and trying also to reduce the transportation costs as much as possible (cost per tonne cargo diminishes with increasing vessel size).



Length Over All:	332.94 m
Length Between Perpendiculars:	320.00 m
Breadth:	60.00 m
Draught:	21.10 m
Deadweight:	300,058 t
Maximum speed:	16.80 knots

Figure 2.23 Ultra Large Crude Carrier 'New Vanguard'

The most important producers (and exporters) of crude oil are the Middle East countries around the Arabian Gulf, such as Saudi-Arabia, Kuwait, the United Arab Emirates, Iraq and Iran, and countries as Nigeria, Venezuela and Indonesia. The most important consumers (and importers) of oil are the countries in Western Europe, Japan and the United States of America. These countries largely depend on the oil from oil-producing countries, especially those of the Middle East. Figure 2.24 illustrates the development of the size of tankers:

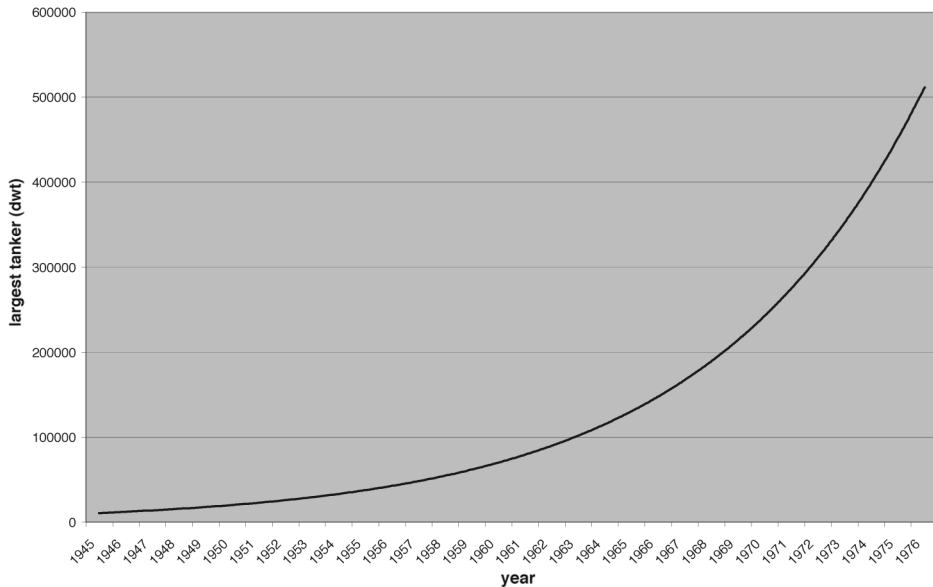

Figure 2.24 Growth of tanker size

Nowadays the intermediate size tanker (50,000-200,000 dwt) is becoming more important again due to:

1. Levelling off or even some reduction in the world crude oil trade.
2. Increased use of the (improved) Suez Canal instead of around the Cape services.
3. The fact that, although *VLCC's* (Very Large Crude Carriers) and *ULCC's* (Ultra Large Crude Carriers) can transport very large quantities of crude oil on one voyage, they can only call at few ports in the world, because of their large draught.

The crude oil tanker can easily be identified by her flat deck without derricks and hatch covers. Only some deck arrangements like stop locks, pumps, pipelines and small hose derricks with the manifold amidships can be observed. A remarkable feature is the cat-walk, a horizontal gangway, that runs along the deck from bow to stern, to enable the crew to move along the ship. Older types of tankers have, like the older general cargo vessels, the main superstructure amidships, but with the newer and bigger types all is aft; superstructure, wheelhouse, engine room, etc.

A remarkable feature of the very large types is the return of the crow's nest at the bow, that is necessary because of the limited view from the wheelhouse aft.

Product tanker (see Figure 2.25). The definition of product tankers given by Lloyd's Register (Lloyd's Register Management Services, 1998) is: a vessel with independent tanks for the transportation of petroleum products in bulk. Many tankers have a dead-weight capacity smaller than 7500 t, but there is a large class of vessels with a capacity between 30,000 and 40,000 t. The largest product tankers are about 110,000 t.

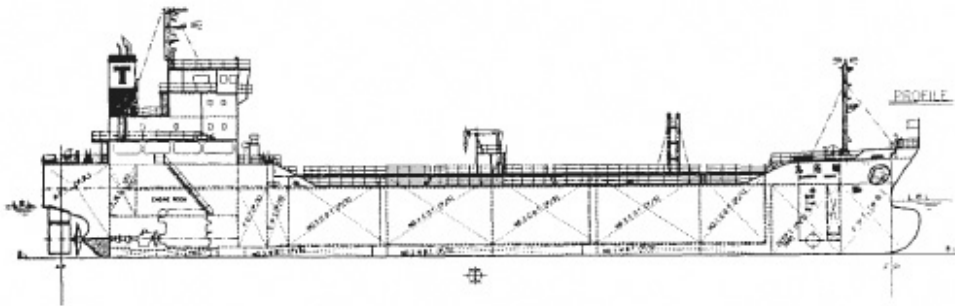
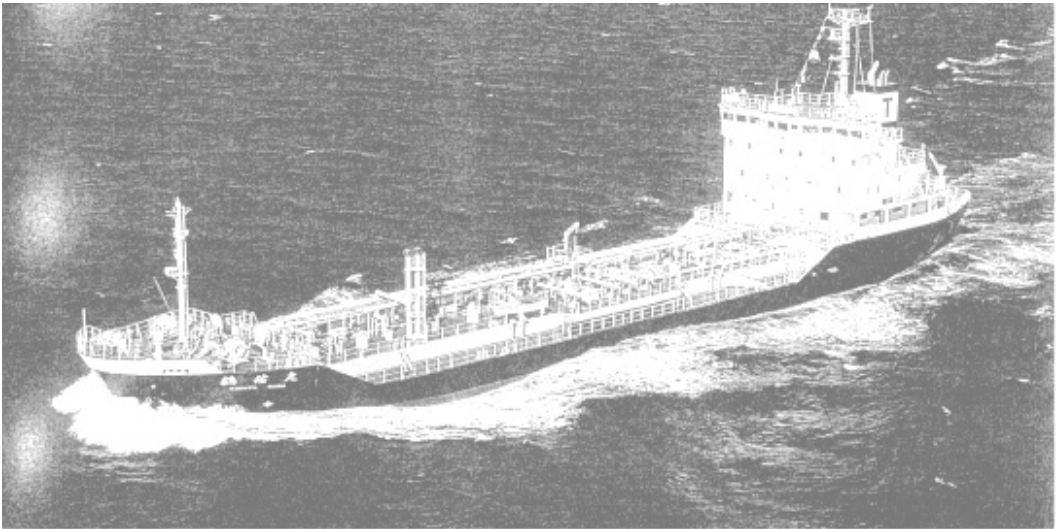

Length Over All:	91.00 m
Length Between Perpendiculars:	86.00 m
Breadth:	15.80 m
Draught:	5.455 m
Deadweight:	3,898 t
Maximum speed:	13.13 knots

Figure 2.25 Petroleum product tanker 'Kakuyu Maru'

Parcel tanker (see Figure 2.26). The parcel tanker is a specialised tanker for transportation of refined oil products, such as paraffin, diesel oil and/or chemical liquids. The parcel tanker has received her name from the fact that the many relatively small compartments in the hold can be used separately, by which various products can be transported at the same time.

The parcel tanker can be distinguished from the crude oil tanker by various additional characteristics, such as numerous small tank hatches, many fore-and-aft running pipes and, amidships, the manifold with its complex arrangements of pipes and valves, connected to the ship's tanks system. The manifold is the focal point of the loading and discharging operations by means of the ship's own pumps. Close to the manifold are two light hose-derricks.

2 Maritime Transport

To reduce the hazards of fire, the holds fore and aft are equipped with double watertight bulkheads (cofferdams). One of the great problems of parcel tankers is the cleaning of tanks. When a certain type of cargo has been brought to her destination, and another type of cargo is to be loaded, the tanks have first to be cleaned. In well equipped ports facilities are available to execute this in a professional way. If this is not the case, illegal dumpings at sea may occur, which may seriously harm the marine environment. A general lay-out of a parcel tanker is given in Figure 2.26.

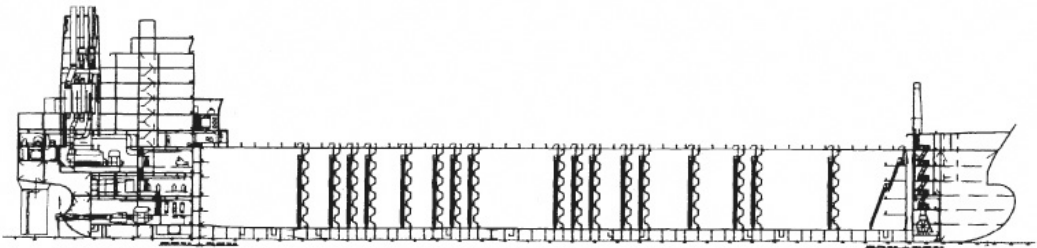

Length Over All:	176.75 m
Length Between Perpendiculars:	168.50 m
Breadth:	31.00 m
Draught:	10.80 m
Deadweight:	37,015 t
Maximum speed:	16.50 knots

Figure 2.26 Parcel tanker 'Stolt innovation'

Liquid gas tanker (see Figure 2.27) The gas is transported at a high pressure or at a low temperature or a combination of both.

The products involved are:

- LPG (Liquefied Petroleum Gas), a mixture of propane and butane,
- LNG (Liquefied Natural Gas), which consists mainly of methane, and
- Other types of chemical gas, like ammonia, ethylene, etc.

The gas is mostly transported at atmospheric pressure and low temperature (LPG: -46°C and LNG: -162°C) in liquid form in separate tanks in the hold of the ship, i.e. the so-called *cryogenic transport*. In liquid form natural gas retains only 1/634th of its original volume. Figure 2.28 gives the development of the liquefied gas carriers. LNG carriers have grown

recently to a capacity of 262,000 m³ with a length of 345 m. For smaller quantities e.g. coaster type and size ships LPG is also transported in pressurised form at normal temperatures. LNG cannot be liquefied by pressurisation at temperatures above -80°C. The capacity of gas tankers is normally expressed in m³. In principle LNG-carriers are capable to transport LPG as well; but LPG tankers cannot carry LNG.

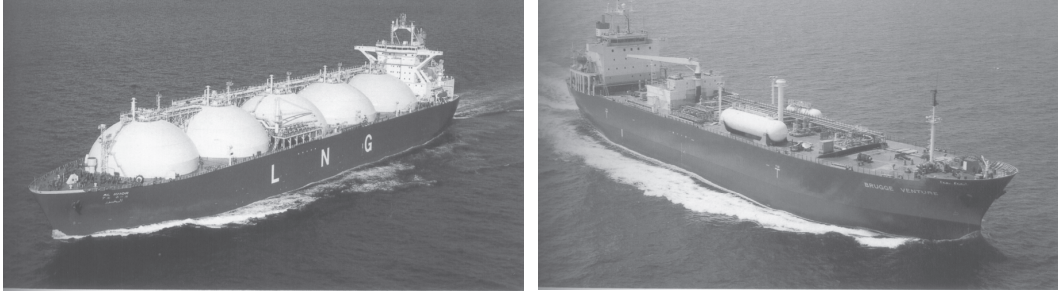

Figure 2.27 Examples of LNG-tankers (left) and LPG-tankers

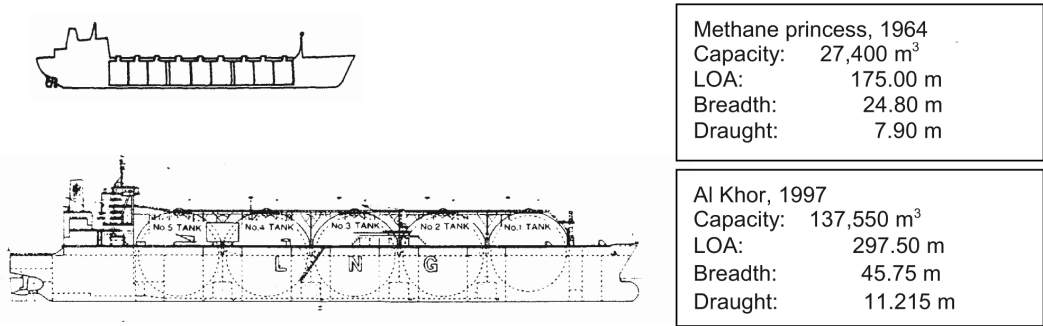
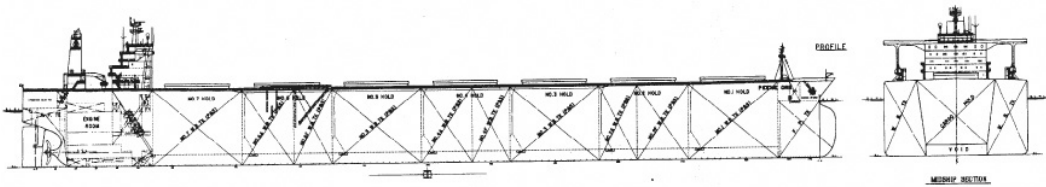

Figure 2.28 Development of liquid gas carriers

Dry bulk carriers

Dry bulk ships are designed to carry big quantities of uniform, unpacked commodities such as grain, coal, ore etc. Loading is always carried out by shore equipment, unloading sometimes by shore equipment, sometimes by ship-based equipment. Many dry bulk vessels are 'ungeared bulk carriers' that have no self-loading capability. *Geared bulk carriers* are equipped with derricks at all holds or with gantry cranes and do not require shore cranes. In contrast to the tanker, the dry bulk carrier has hatches. The hatches are usually very wide, in order to give access to the handling equipment in every place in the holds. Until recently the largest bulk carriers in use (*VLOC's = Very Large Ore Carrier*) measured about 350,000 t, see Figure 2.29. But in 2011 the first 6 out of 19 ULOC's (Ultra Large Ore Carrier) ordered by the Brazilian mining company Vale have come into operation. They are also referred to as Valemax or Chinamax carriers - as they are intended for the export of iron ore from Brazil to China - and have the following characteristics: 400,000 dwt, L_{OA} = 362 m, D = 23 m.



Length Over All:	332.00 m
Length Between Perpendiculars:	320.00 m
Breadth:	58.00 m
Draught:	23.00 m
Deadweight:	322,398 t
Maximum speed:	14.70 knots

Figure 2.29 Very Large Ore Carrier 'Peene ore'

Some types of dry bulk ships, the CSU's (Continuous Self Unloader), are self-discharging via an ingenious conveyor system. Capacities up to 6,000 t/hour can be reached (see also Figure 2.30). The advantage of these self unloaders is that only some dolphins are necessary for a berth.

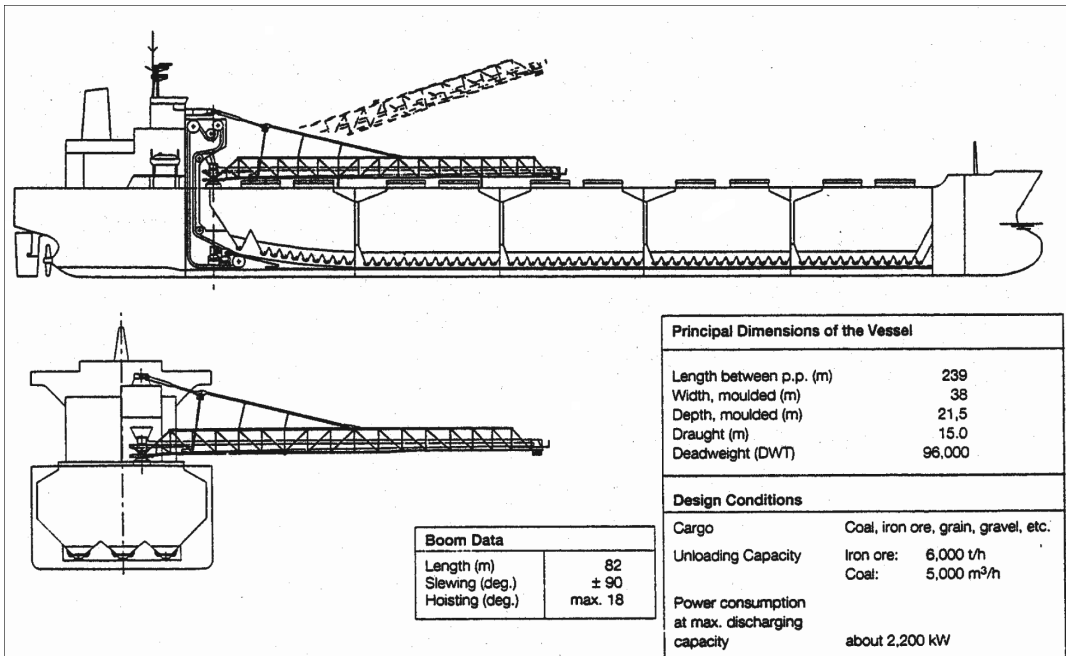

Figure 2.30 Self-unloading gear of the M/V Western / Eastern Bridge

2.3.7 Short Sea Trader

The short sea trader is a sea going ship with a capacity of between 300 and 3000 dwt. In several countries short sea traders with capacities ranging from 300 to 1500 GRT are referred to as *coasters*. Usually, the short sea trader runs the shorter routes, connecting the ports around the North Sea, the Baltic Sea, the Mediterranean Sea and similar areas in the world. As discussed in the previous chapters, the size and therefore also the draught of ocean going vessels have increased sharply over the past decade. This has increased the importance of *short sea traders*, mainly due to the following two reasons:

- Large vessels tend to call at as few ports as possible, in order to reduce costs, and
- Large vessels are no longer able to call at every port due to restrictions caused by the dimensions of the ships

To maintain the connection between the ports of call of the large vessels and the other ports the short sea trader is a most useful tool. If a short sea trader is employed in this way, she is also referred to as *feeder*. Due to her limited dimensions the ship can call at most ports. Furthermore it can be observed that she is economic in use, because of the simplicity of the ship and the small crew. The short sea trader can transport any kind of cargo, such as general, palletised, containerised or bulk cargo.

Depending on the type, the short sea trader is often fully equipped with cargo handling gear, which also enables her to load or unload cargo at small ports with limited facilities.

2.4 Tramp and Liner Trade

International shipping can be subdivided into two major categories:

- liner trade
- tramp trade

2.4.1 Liner Trade

Liner trade is a seaborne trade of one company (or a consortium of companies), which maintains regular services between a certain number of ports. Within this trade one can further distinguish main routes: east-west and vice versa, north-south and vice versa and short-sea lines. The latter provide a regular service between a number of ports at the same continent, e.g. Rotterdam-Bilbao-Southampton-Rotterdam. The essence of all these lines is:

- Times of arrival and departure in any port of the route are scheduled (and published) over a certain period in advance; high reliability
- Tariffs are fixed over a certain period
- Berth location in most ports is fixed

In container shipping a peculiar phenomenon developed, i.e. main lines, which call on only few ports in their route, with *feeder ships* collecting and distributing the containers within a region around such a *main port*. Another name for this system is *hub-and-spoke*. The reasons for this development are clear: the main line vessels were becoming too large and too expensive to call on smaller ports. The transfer from main line vessel to feeder and vice-versa is called *transshipment*. The total container throughput of the main ports comprises hinterland cargo and transshipment cargo, the latter being counted double (on entering and on leaving the port). Singapore port has mainly transshipment cargo, whereas in Rotterdam the container throughput is about 15 % transshipment.

Throughout the past decades competition between the main line shipping companies, the *mega carriers*, has led to concentration and rationalization. Concentration implies mergers and takeovers, leaving only about 18 companies to provide the intercontinental services. Rationalization has also been applied to maximize slot usage, in other words, to make sure that the vessels are loaded up to TEU capacity. This is achieved by forming consortia or alliances (see Table 2.6).

Another way to achieve optimum usage of the capacity of scheduled ships is slot sharing. This implies the chartering of container space (slots) on a competitors vessel on an as-need basis. Notwithstanding all these measures to improve shipping economy, presently the relative overcapacity leads to low tariffs and poor performance of most shipping companies.

Table 2.6 Alliances container shipping (2017)

Name	Members	Number of ships	Fleet capacity
2M Alliance	Maersk MSC	185 ¹⁾	2.1 Million ¹⁾
Ocean Alliance	CMA-CMG Casco Shipping Evergreen	324	5.5 mio
The Alliance	Hapag-Lloyd NYK MOL K-Line Yang Ming	620	3.5 mio

¹⁾ Operating in the alliance services

2.4.2 Tramp Trade

Tramp trade is the opposite form of seaborne line trade. It is being applied whenever or wherever needed. Tramp trade is mostly found in the bulk shipping trade, where the markets are more volatile than in merchant shipping. Sometimes tramp ships are contracted by liner companies on short or long term contracts, in case their own fleet is not adequate or available to provide the services required. Chartering occurs through open markets mainly in London and New York. The chartering through open markets is reason for strong varying tramp tariffs because of the limited flexibility of the transport capacity. Therefore raw materials processing industries are concluding long term contracts. This security of long term contracts offers the possibility to use larger and more specialized bulk carriers.

To illustrate the importance of tramp shipping, the distribution of the world crude oil transports in 2015 as follows (CRSL, 2015):

Approx. 9 % was transported by vessels owned by the major oil companies

Approx. 82 % by independent tramp companies, which have leased their ship on short and long term contracts to oil companies and oil traders

Approx. 9 % was carried out by ships owned by governments

2.5 Graphs and Observations

Some graphs with respect to the main dimensions of ships are presented in the following Figures (based upon data from Lloyds Register of Ships and other sources).

With reference to Section 2.3.6 large ships are often referred to as being ‘‘Panamax size’’, ‘‘Suezmax size’’, etc., reflecting the fact that they have dimensions just allowing them to pass the Panama Canal locks, the Suez Canal or similar important natural of

2 Maritime Transport

man-made barriers for navigation. Ships can be adapted to the restrictions imposed by these obstacles but, sometimes and within limits, the obstacles can also be adapted to the demand for the passage of bigger ships. It is a complex balancing act controlled by economic and strategic considerations. If transport chains and the related infrastructure were managed by one and the same party, this balancing act would be relatively simple, but in practice there are a number of stake-holders and non-rational aspects that come into play.

Canals and natural channels can in principle be deepened and widened and ship-locks can be replaced by bigger ones, but usually all at considerable cost. Ship-locks constitute a limiting factor for the reception or passage of big ships at quite a number of locations, not only in Europe.

Important ship-locks and their lock chamber dimensions (LxBxD) are:

- Panama Canal, new locks operational in 2016:, 427 x 55 x 18.3 m.
- Antwerp, Berendrechtsluis, 500 x 68 x 13.6 m, and Kieldrechtsluis (2016), 500 x 68 x 17.8 m, the world biggest for the time being.
- Bremerhafen, Kaiserschleuse, 505 x 55 x 13 m, particularly for the passage of car carriers.
- IJmuiden, Noordersluis, 400 x 50 x 15 m, new lock under construction, 500 x 70 x 15 m.
- Terneuzen, access to the port of Gent, construction of new lock to be started end of 2017: 427 x 55 x 16 m.
- Le Havre, écluse François I, 400 x 67 x 24 m.

The limitations imposed by ship locks on shipping are not only a matter of size of the locks but also of delays caused in transiting the locks and the fear by shipping lines that operate on a strict time schedule, e.g. main container lines, to have their ships "imprisoned" in port for an indefinite period of time in case of damage to the vulnerable lock doors. For that reason and for quite some time already ports like Antwerp and Le Havre have been shifting part of their container operations to the tidal waters outside the locks notwithstanding the fact that quay wall construction is far more expensive there and that STS crane productivity is lower. For example at tidal berths in Le Havre quay walls and cranes have to cope with a tidal range of some 8 m.

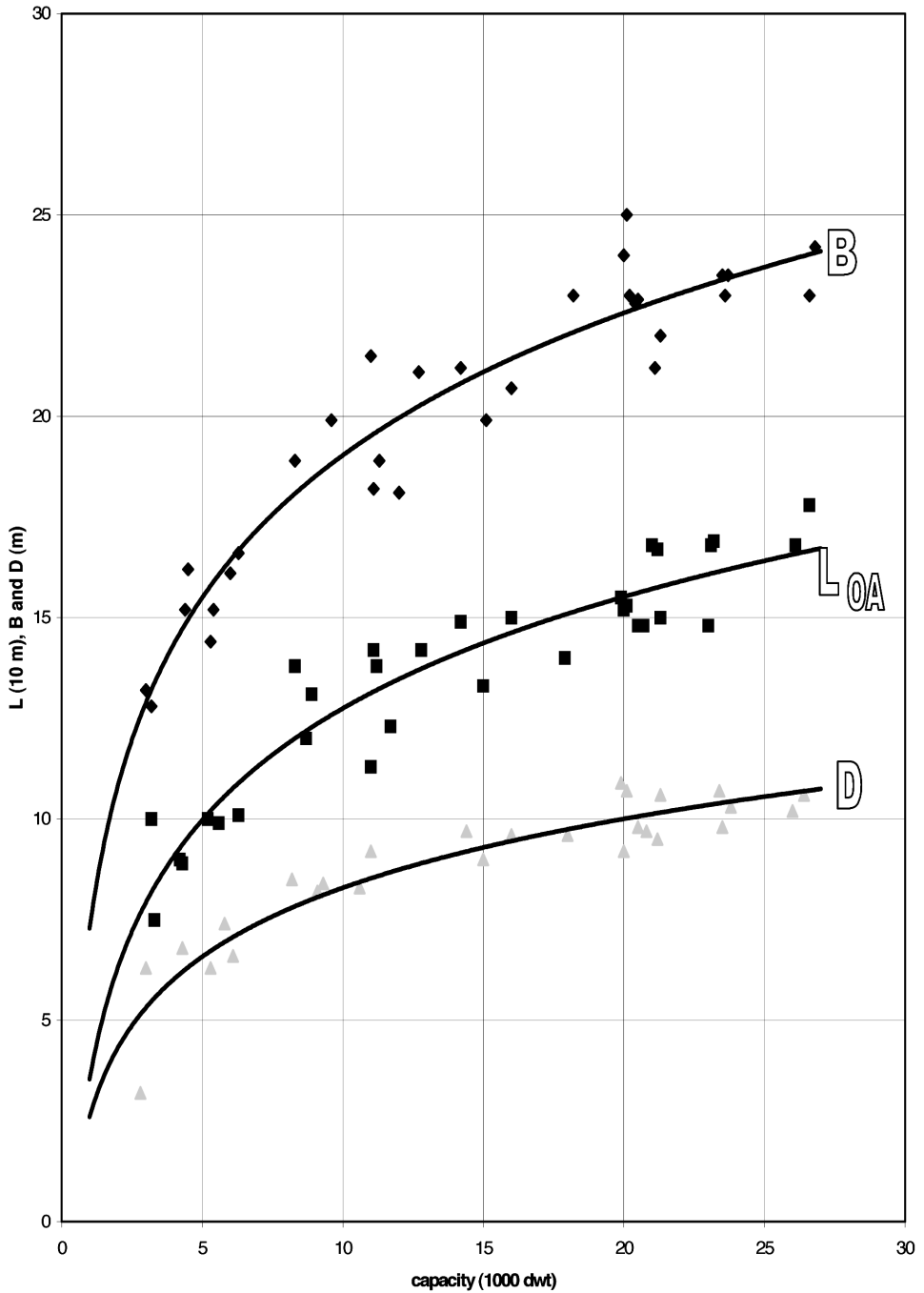

Figure 2.31 Principal dimensions of general cargo ships

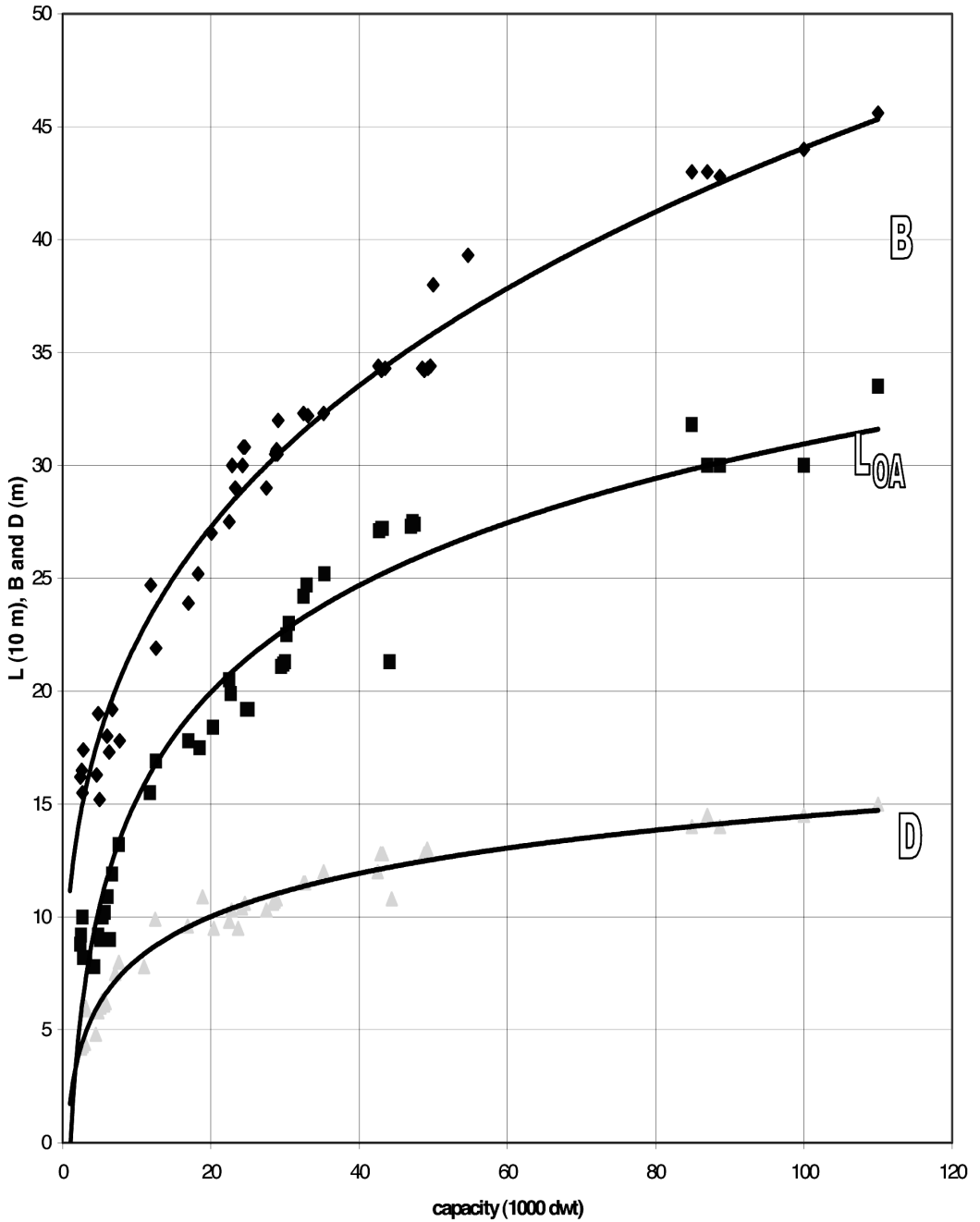

Figure 2.32 Principal dimensions of container vessels

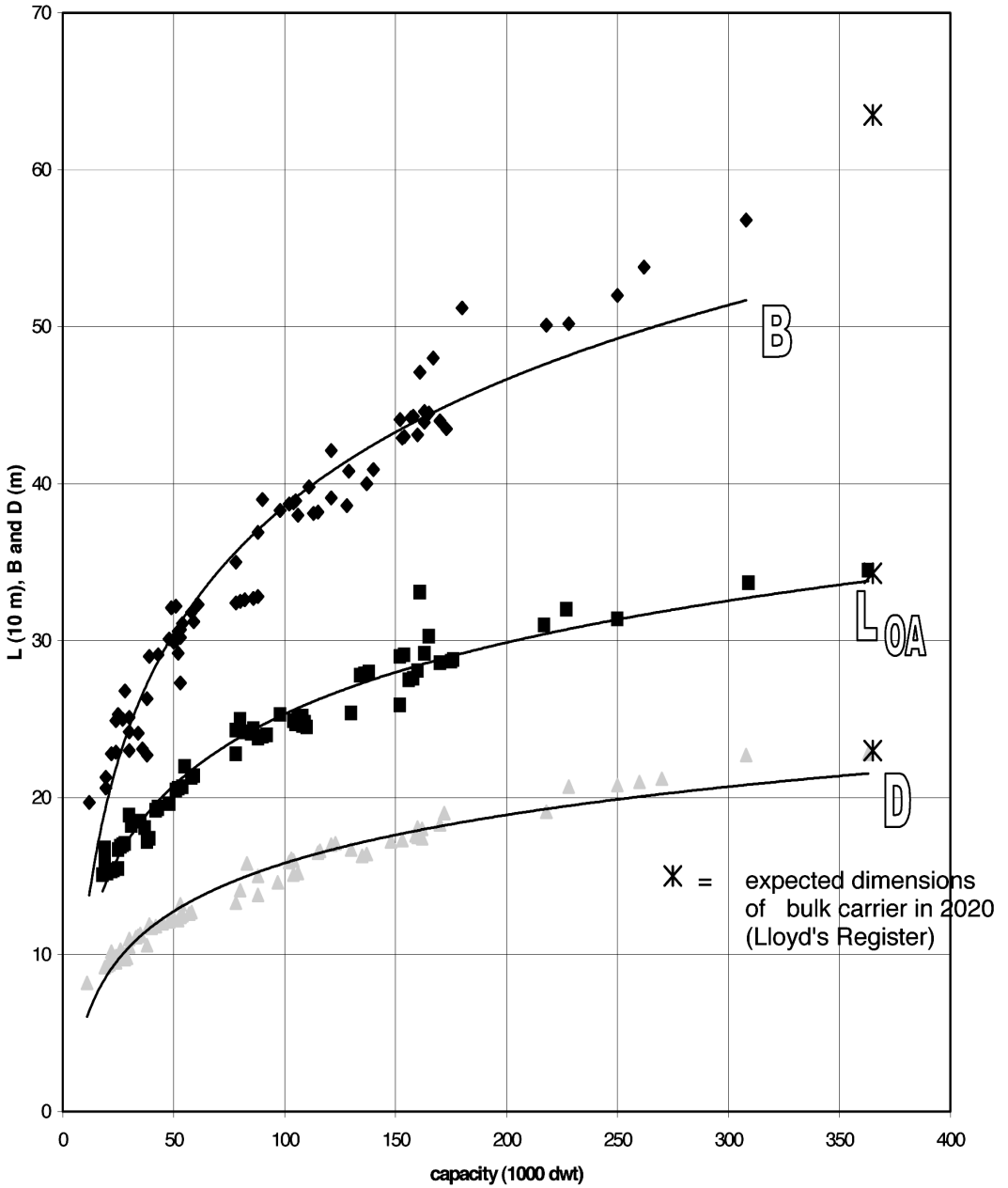

Figure 2.33 Principal dimensions of bulk carriers.

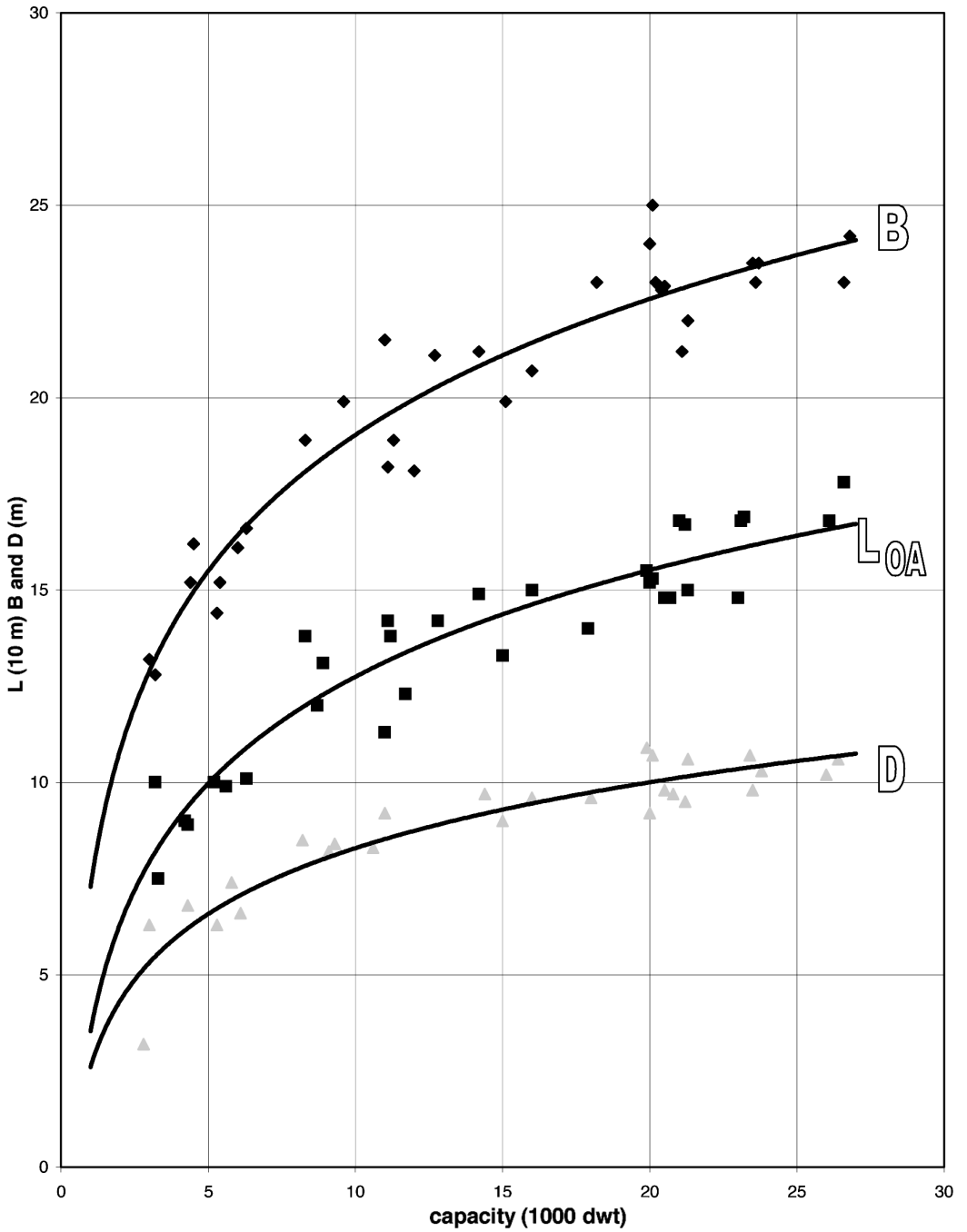

Figure 2.34 Principal dimensions of tankers

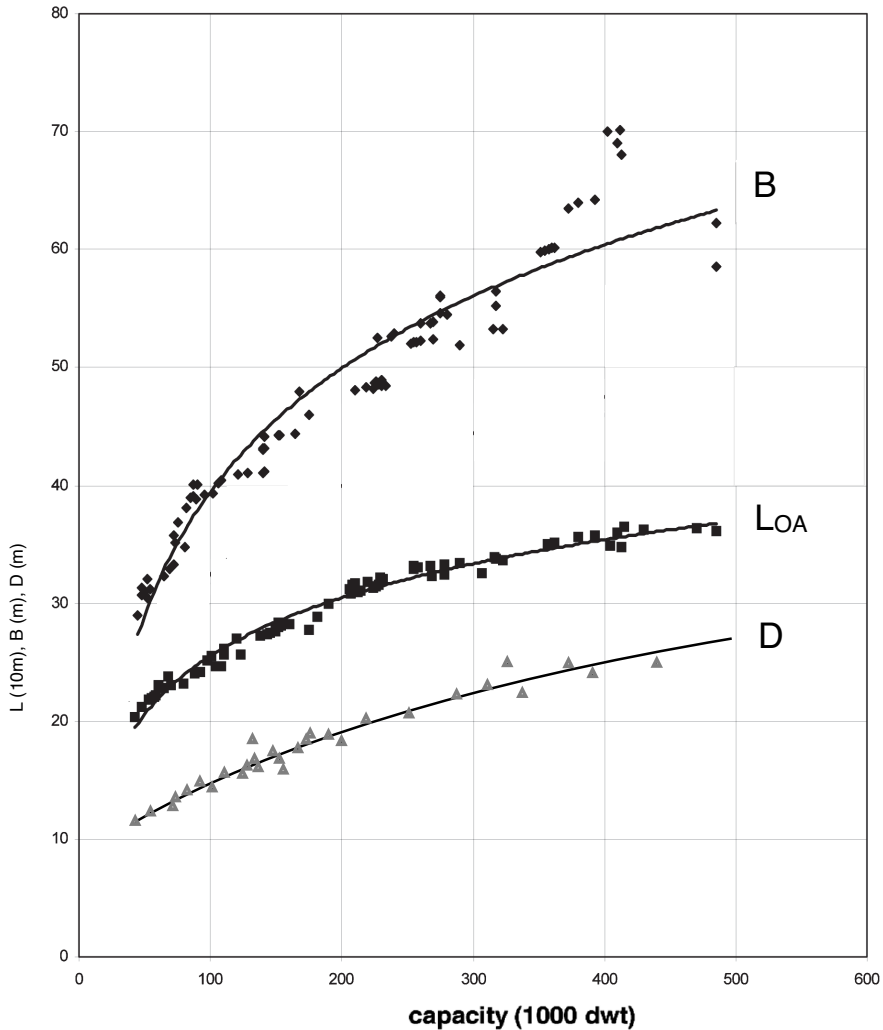

Figure 2.35 Principal dimensions of tankers > 40,000 t

2.6 References

- Ashar and Rodrigue, Evolution of Containerships, The Geography of Transport Systems, 2012.
- Clarkson Research Service Ltd. (CSRL), The tramp shipping market, London, 2015.
- Kruk, C.B and Heer, R.J. de., Merchant Shipping, & Cargo Handling, IHE Institute for Water Education, Delft, 2005.
- Lloyd's Register Management Services, Ship dimensions in 2020, Rotterdam, May 1998.
- Wijnolst, N. and Wergeland, T., Shipping, Delft University Press, 1996.

Chapter 3

Port Functions and Organisation

3.1 Introduction

Before entering into planning and design of ports it is necessary to determine the functions of a port and to understand its organisation. Both factors are relevant for the economic and financial decisions to be taken as part of the planning process. Over the past decades privatisation of (public) ports and private development of entirely new ports have become a trend, but the success of these policies depends very much on the function and the legal and institutional conditions of the port concerned.

3.2 Functions

The primary functions of a port are:

- Traffic function: the port is a nodal point in the traffic, connecting water and various land modes.
- Transport function: ports are turntables for various cargo flows.

Besides these, ports can have several other functions, such as:

- Industrial activities, often in relation to the cargo flows, to shiprepair and shipbuilding, or offshore-supply. But the vicinity of sea transport may in itself be the reason to locate an industry.
- Commercial and financial services, including banks.

The traffic function requires three conditions to be fulfilled, i.e. a good "front door", a good "backdoor" and sufficient capacity and adequate services in the port itself:

- Entrance from sea, needs to be accessible and safe;
- Port basins and quays, adequate space for manoeuvring and berthing of the ships, capacity for handling and storage;
- Hinterland connections, road, rail, inland waterways, pipeline, depending on the transport function.

The safety of ships and crew is most important and receives much attention. This is understandable, when recognising that ships are designed for manoeuvring in open water and at cruising speed. Entering a port means speed reduction, entailing poor manoeuvrability, stopping in limited waters and often having other ships around. For this reason the nautical services are essential: starting with nautical aids (buoyage, lights), getting pilot assistance and tugs, and moving to high-tech aids to navigation: the *Vessel Traffic Service (VTS)*, which implies monitoring of all vessel movements in a port by central radar and AIS.

However, a port with very good nautical entrance, but insufficient space and/or bad hinterland connections becomes quickly clogged and does not function. Hence the above three conditions must be in balance.

Regarding the transport functions the conditions are depending on the particular situation of the port:

- i. if a port has its 'natural' hinterland, which it serves for import and export without much competition, it is in the interest of society that this service is provided efficiently, uninterrupted and at minimum costs. The absence of competition led in the past to 'public ports', which often failed to achieve these goals. They became either 'money earners', or had more ships at anchorage outside than berthed inside the port, or both.
- ii. Where several ports are competing for cargo from and to the same hinterland, or for the transshipment trade, the efficiency of cargo handling and costs for pilotage, harbour dues, etc. becomes important. Ports become business in itself and privatisation of port functions is a logical step to achieve the necessary efficiency.

In Section 3.4 this issue of public versus private will be further elaborated. Here the question is posed whether the transport function deserves to be expanded in a competitive situation. The investment costs are high, which benefits justify them? This question has become more relevant, since the direct employment in the port has reduced drastically over the past decades as a result of improved handling methods and automation. An answer is obtained by carrying out a thorough financial analysis in case of a private port project. In case of a public port both financial and economic analysis is required, the latter taking into account social costs and benefits (de Brucker et al, 1998).

Some other considerations are also applicable:

- Competition between ports is good to stimulate efficiency, and to keep the costs down. Too much competition leads to overcapacity and losses, which in most cases is paid for by the public.
- Unfair competition (e.g. by subsidies) should be avoided, because it leads to price distortion (European Commission, 1995) and overcapacity.
- Ports should strive to include employment generating activities in their development-strategies, in order to maintain the positive profile and public support in the local community.
- Environmental effects have to be taken into account on a rational basis, e.g. by quantitative evaluation methods and against a uniform and transparent set of regulations.
- Sustainability has become an important aspect of port development. Reducing the emission of greenhouse gasses, reuse of excess heat and industrial rest products within the port area, use of durable materials and recycling, all these measures should be taken into account. This is elaborated in Section 4.7.
- Stakeholder involvement is another issue, that is part and parcel of any major port project. It has become part of the requirements of an Environmental and Social Impact Assessment (ESIA) as defined by international financing organizations such as WB and IMF, but also by national governments.

The above aspects are all related to the investment decision in the planning stage of port expansion. In the direct competition between ports to attract certain trades and cargo volumes the following competitive factors are all important:

- Availability of land for terminals and the related cost per m².
- Port tariffs and dues.
- Quality of the port and/or existing stevedores (efficiency, reliability, flexibility, handling costs).
- Quality of the hinterland connections.
- Environmental requirements.
- Customs regime.
- Nautical safety.

In order to be able to attract new business, the port must have some excess space. It is important to realise that this may also be found inside the existing port boundaries, for instance where old and declined areas have become obsolete and can be converted to suit the requirements of new trades.

This process has been observed in many existing ports and is described in the so-called *Port Life Cycle theory* (Charlier, 1992). The cycle, shown in Figure 3.1, implies that a port area develops with the growth of cargo throughput, reaches maturity (or saturation), starts to age (due to changes in cargo pattern or in ship design) and then reaches a state of obsolescence, which will continue, unless a revitalisation process is initiated.

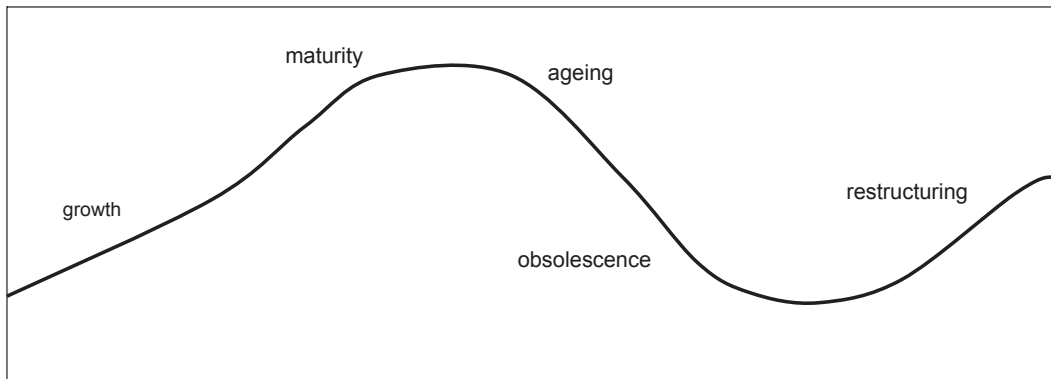

Figure 3.1 The Port Life Cycle (Charlier, 1992)

The change-over from conventional general cargo to containerised cargo is a good example. In many ports this has made existing terminals obsolete, leaving deserted areas with empty warehouses.

The message is to start the revitalisation process before this happens, as soon as the signs of ageing become clear. This is a task for the port authority, but involves port planning in the same way as expansion outside the existing port boundaries.

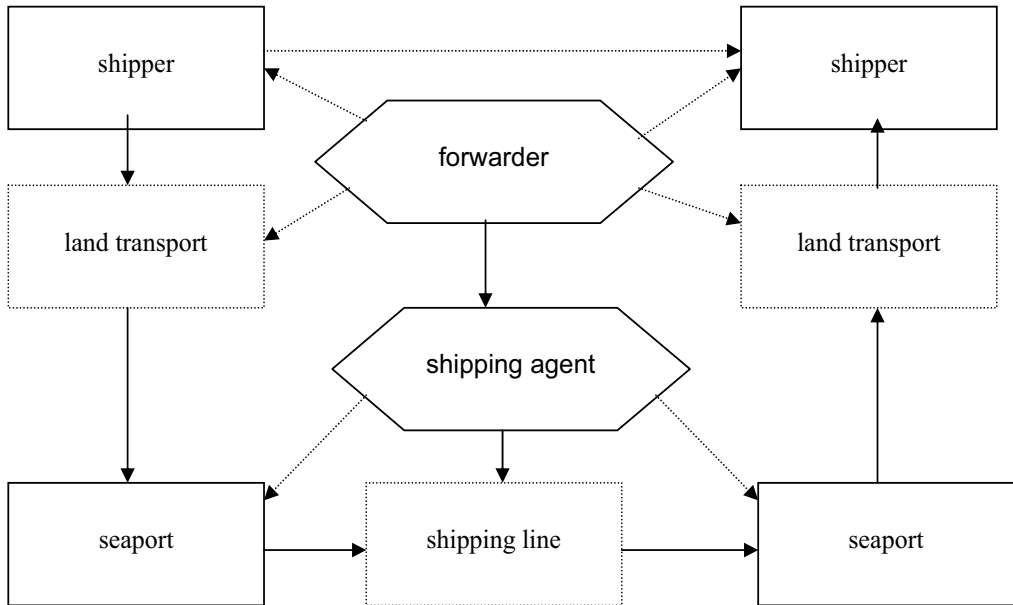

Figure 3.2 Elements in the transport chain

3.3 Transport Chain

In the previous section the transport function is stated to be carried out by the 'port'. Nowadays there are only few ports in the world where the port authority is also responsible for the ship unloading/loading and the storage of the goods. Often these activities are supplied by a stevedoring firm, that is specialised and therefore can provide better services at a competitive price. The place of the stevedore in the overall transport chain is shown in Figure 3.2. This scheme also explains the role of two other agencies: the forwarder, who is hired by the shipper of the cargo (not to be confused with the shipping company) to arrange the land transport, and a shipping agent, who in turn arranges the shipping line and the stevedoring in the seaports on both ends. This process is identified by the term 'merchant haulage'. For large cargo volumes at regular intervals over a period of several years, forwarders tend to prefer one contract for the entire transport chain. In response to this, shipping companies have started to offer 'door-to-door' services, in particular for containerised cargo, so-called *carrier haulage*. And as a logical step shipping lines diversified their business to include land transportation and stevedoring. An example is APM Terminals as a subsidiary of the shipping line Maersk.

At this point it is relevant to mention the growing market for intermodal transport. In Chapter 2 the competition between road, rail and IWT for the hinterland transport was sketched. Intermodal transport concerns the combination of rail with road and IWT with road. The present policy in Europe is to stimulate this intermodal transport in order to reduce the congestion of the road network and for environmental reasons. To illustrate the latter point Figure 3.3 gives the number and the total length of all units placed one behind the other that the different transport modes need to carry 12,000 ton cargo. This is an indication of the corresponding energy consumption and air pollution.

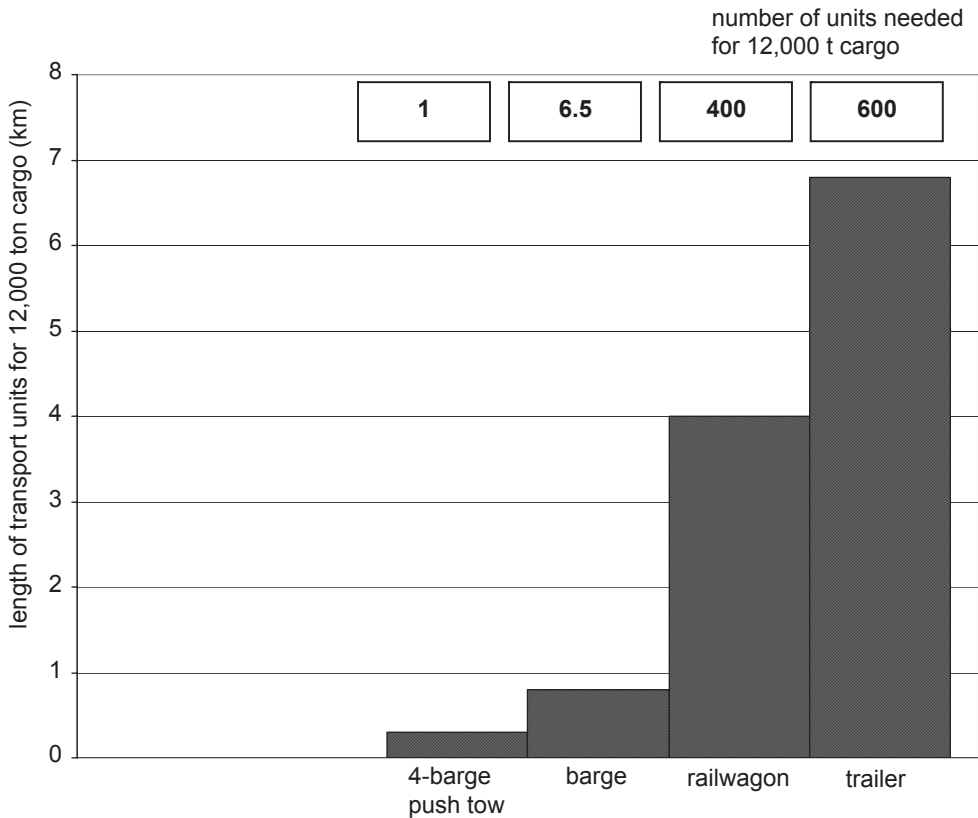

Figure 3.3 Length of all transport units in a row for different modes

Promotion of intermodal transport can be achieved by improvement of rail infrastructure for cargo (e.g. the Betuwe Line in the Netherlands) and the infrastructures for IWT (widening of the Meuse and of various canals). Additionally there exists a subsidy for the private development of terminals along rivers and canals.

3.4 Organisation of Seaports

It has been mentioned that many ports started as a public organisation. Consequently they were government-owned, be it the National Government, a municipality, or a separate status of Port Trust or Port Authority. Exceptions were so-called *captive ports*, built and operated by an industry for its own use, such as the tanker berths for a refinery or the bulk export terminal for a mining company.

World-wide one can distinguish three different forms of organisation of the public ports:

- *The Service Port*: all services including cargo handling and storage are provided by the port authority. This form was common in the old times and can still be found in some developing countries. It was often characterised by bureaucracy and red tape and can only survive in case there is a natural hinterland without competition of other ports.

- *The Landlord Port*: the port authority owns the land and gives concessions to private sector companies for provision of cargo handling and storage services. The port authority is responsible for the infrastructure, the nautical safety and access, including maintenance of approach channel and basins.
- *The Tool Port*: the port authority remains responsible for providing the main ship-to-shore handling equipment (usually light to medium multipurpose cranes), while cargo handling is carried out by private companies under licences given by the port authority.

A 1997 world review of the top 100 container ports shows that 88 out of 100 ports conform to the Landlord Port model. This is therefore becoming the standard, but for small ports, assuming 250,000-300,000 t of general cargo per annum to be minimum for an independent cargo handling company to be financially viable. Below this level the Tool Port model appears to be more appropriate.

Besides these public ports, fully private ports are becoming more common. These are ports built and operated by private companies, including the responsibility for maintenance. Statutory functions like navigation safety, environmental protection and customs remain government responsibility (Juhel, 1999)

The latter so-called *Built-Operate-Transfer (BOT)* projects are seen by many politicians all around the world as an attractive way to create infrastructure and thus overcome congestion in the existing ports without public finance. The reality is that the return on investment of most projects is insufficient (based on a 30 year pay-back period). Consequently the only way to realise them is by a combined approach, i.e. public finance of certain basic infrastructures and private financing of the rest. This is either achieved by following the "Landlord" approach, or in a commercial investment by public and private partners jointly, the *Public Private Partnership (PPP)*. This approach has been followed by Amsterdam Port Authorities in the realisation of several new terminals.

The advantages of various degrees of private sector investment and participation are clear:

- i. It offers a good test on the financial feasibility of the port project (private sector is not interested in 'white elephants')
- ii. Once in operation the efficiency and profitability of the port is driven by the commercial interests of the private partner, and less by social and political considerations. A good example of this is the privatisation in 1989 of quite a number of ports in the United Kingdom, under the name Associated British Ports. In six years time ABP had turned them around and made profit. This was achieved by labour reductions of 85% of the original workforce. And notwithstanding this reduction the total throughput showed a 13% increase.

3.5 References

Brucker, K. de, et al, Sociaal-economische evaluatie van overheidsinvesteringen in transportinfrastructuur, Leuven, 1998

3 Port functions and organization

Charlier, J., The regeneration of old port areas for new port users, in European cities in transition, ISBN 1-852-93170-1, 1992

European Commission, Towards fair and efficient pricing in transport: public options for internalising the external costs of transport in the European Union, report COM (95) 691, Brussels, 1995

Juhel, M.H., Global changes for Ports and Terminals in the new Era, Journal Ports and Harbours, March 1999

Chapter 4

Port Planning Methodology

Co-authored by Cornelis van Dorsser, Poonam Taneja and Tiedo Vellinga

4.1 Introduction

Port planning deals with the development of a new (green-field) port, the expansion of an existing port or the conversion of older (brown-field) port areas. In all cases the plans have direct impact on the surroundings, be it built or natural environment. In most countries port development is by law subject to national, regional and/or local approvals. In these countries the permitting processes require execution of an Environmental and Social Impact Assessment (ESIA), including extensive stakeholder involvement. In addition a social cost benefit analysis or economic analysis is often required to obtain approval from the government and/or funding from a development bank, such as the World Bank.

The planning process therefore has two lines: (i) the technical studies, financial analysis, and proposed financing solution that are carried out by the initiator (port authority or terminal owner/operator) and (ii) the ESIA and (in some cases) economic studies that are part of the legal permitting and governmental approval process. While there is much interaction between the two lines, they are treated separately in the Sections 4.4 and 4.5.

Section 4.2 and 4.3 start with some definitions and a general description of the planning process. In Section 4.5 the financial and economic studies are discussed in more detail, including the role of the Business Case, that has become an important guiding element in port development. In Section 4.6 a new and inspiring aspect in port planning is presented: how to make the port more sustainable. And in Section 4.7 a new approach in port planning is introduced, that allows to take the uncertainties better into account.

4.2 Types of Planning

Depending on the time horizon the following types of planning can be distinguished:

Type	Time horizon(years)	Example
long-term	20-30	masterplan
medium-term	5-10	phases of a masterplan
short-term	2-3	minor lay-out changes

Furthermore the type of planning may vary depending on the scope and geographical extent:

- national or regional port planning
- planning of individual ports

The purpose of a masterplan is to have a blue print for future development, reserving space where it may be needed in the future, taking account of regulatory and environmental requirements, and creating an efficient and economic port operation. National and regional master plans for port development were aimed at creating the optimum allocation of functions within a country or a region, often including industrial development. This should take into account existing port capacity, hinterland connections, labour potential and natural resources, and cost of the infrastructure. Such plans were made during the past decades for many countries in transition, often with assistance of the World Bank or other development banks. The accent lies here on economics: assessment of cargo flows for all commodities and cost/benefit analysis for the individual port projects leading to an optimum overall plan. The port planner plays a role in the evaluation of existing ports (can the efficiency and throughput capacity be improved, often even without new infrastructure), and in preparing lay-outs for new port facilities or extensions where appropriate. Preliminary design of infrastructure is needed to determine costs, but this is not done in great detail.

While it is evident that this type of planning is useful to make sure that the right investments are made at the most appropriate locations, it must be realised that this approach of setting out a national/regional development part is very difficult and often has limited applicability over longer periods of time. This has the following reasons:

- iii. Insofar as the plan affects the future of existing ports in a negative way (limitation to certain type of cargo and hence in overall growth) the port authority and local community will resist it. Political lobbying starts to adapt the plan and otherwise one will ignore it.
- iv. Several years after the plan has been formulated, the actual cargo flows and operational performance may deviate considerably from the projections, conditions may have changed, resulting in the plan to become ineffective.

Western countries do not apply this type of national port planning anymore. What does happen is that in preparing the masterplan for an individual port (expansion), the possible overcapacity of neighbouring ports in the country is considered. An example of this is the earlier stage of the planning process for Maasvlakte 2 in the Netherlands.

With respect to the planning of individual ports a further distinction is made between expansion/ restructuring plans for existing ports and the planning of a new “green-field” port. The process is very similar in both cases, with the difference of a site selection study that is often part of the green-field port development.

The need to expand (or restructure) an existing port may arise from different external conditions (PIANC, 2014):

- The port (or a part of it) has reached its limit of berth capacity and/or terminal capacity
- Certain parts within the port are becoming obsolete, because of a change of cargo

4 Port planning methodology

types (e.g. reduction of General Cargo transports) or a change of vessel size (e.g. increase of the draught of container vessels)

- Emerging land use conflicts between the port and adjacent occupants (e.g. port-city interaction)

Green-field port development is in most cases driven by the following needs/opportunities:

- Dedicated terminals for the export of mining products, crude oil or refinery products, that need to be located near to the mine, exploitation site, refinery, etc. The development of these terminals is often a (small) part of the overall project and hence the port is privately funded.
- Strategic industrial port development in relation to planned regional development. This is often based on government policy and hence has to rely on public funding for the basic infrastructure.

Coming back to the types of planning according to time horizon: generally the long-term, medium-term and short-term plans are interrelated. The masterplan provides the framework for medium-term plans, while these in turn form the basis for short-term projects. The masterplan needs an update at intervals of about 5-10 years, during which the actual throughputs are compared with the original projections, the latter are adjusted, and accordingly the original phasing is reviewed and updated. In this way one could extend the lifespan of the masterplan and achieve a continuous planning process, as visualised in Figure 4.1. In this example the time that the construction of the Phase 3 infrastructure has to be finished is brought forward by 2.5 years because the (updated) throughput forecasts show a larger growth.

Original Master plan and Phase 1

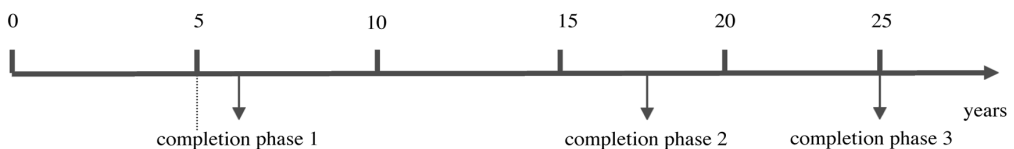

Update Master plan after 5 years

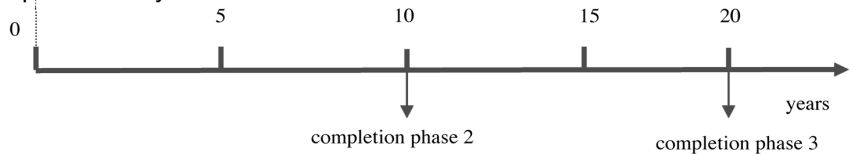

Figure 4.1 Rolling master plan

In practice there are not many ports in the world, that apply this process systematically. The updating of the masterplan (if one exists) is often more ad-hoc, when the need arises. And short-term plans are more often than not unrelated to the masterplan.

This does not mean that the masterplan should not be made. It simply shows that a masterplan should be flexible enough to follow fluctuations in economic development and changes in the transport patterns.

A further step in enhancing the flexibility of the masterplan is the so-called Adaptive Port Planning (APP) methodology, whereby uncertainties and underlying assumptions are made more explicit and are being monitored on a continuous basis. This is explained in more detail in Section 4.8.

A final two comment is made with respect to masterplanning: there is not much difference in the masterplanning of a port with only commercial functions and a captive industrial port. Examples of the latter type are terminals for the export of coal and iron ore and crude oil or refinery products. In both cases the future requirements in terms of space and capacity can be projected within reasonable limits. This is different for industrial ports that are part of a regional development, where the decision of industries to locate their business there is uncertain. In this case the masterplan gets more the character of a strategic plan and the need for flexibility in realizing it becomes even stronger.

4.3 Overall Planning Process

The two lines in the planning process mentioned in Section 4.1 are presented in Fig. 4.2 and will be described in more detail now.

The need for an increase of port capacity becomes clear when available space for new terminals or new industries diminishes or the waiting times of vessels become too large. In this case the port authority shall start the process of investigating the basic options (additional facilities or improving productivity), possibly leading to the definition of a port expansion project. But it may be a government that decides to create a new port as part of a (regional) development program. Or a mining company that has obtained a new concession and needs an port facility for the export of the products.

In all these cases the project is initiated by carrying out a Preliminary Feasibility Study. This study comprises (at a rather high level) the technical and financial feasibility and in some cases the economic feasibility, looks into options for financing the project, and identifies possible hurdles in respect of environmental or social impacts (without going yet into a full ESIA) and ways to circumvent these. If the results of this study prove to be positive this allows the initiator to present it to the responsible government department, requesting to start the regulatory process. At the same time the Technical Masterplanning can be started.

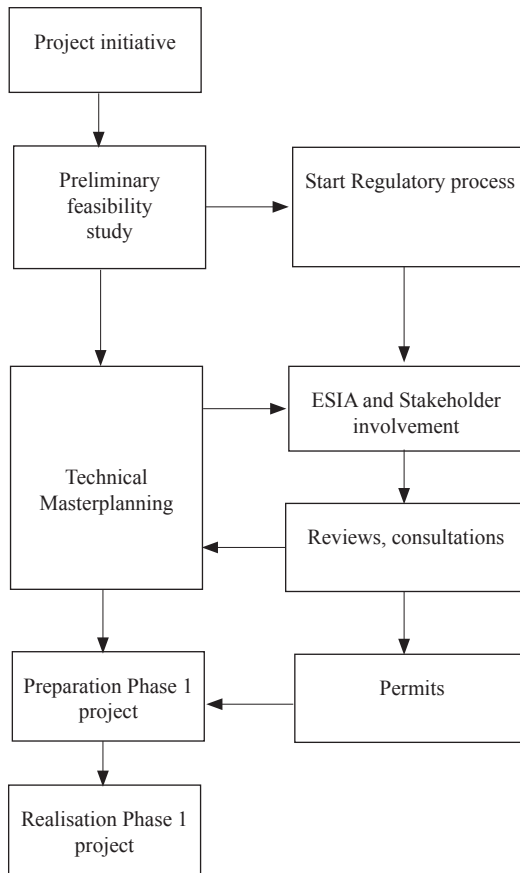

Fig. 4.2 Overall planning process

In the Masterplanning study the future throughputs are projected, (additional) capacity requirements defined, alternative port lay-outs drafted and evaluated, leading to a preferred lay-out that is then subject to a financial analysis and in some cases an economic analysis. The lay-out drawings and throughput figures form the basis for the Environmental and Social Impact Study (ESIA) that is undertaken by the Initiator, but as part of the regulatory process.

The results of the ESIA and of stakeholder meetings, that are either part of the ESIA or organised in parallel, are reviewed by government. Feed-back is given to Initiator, which may lead to adaptations in the Masterplan. When this has eventually received governmental approval the 1st phase of the Masterplan (or the port expansion plan) can be prepared in more detail. An important part of this step is to finalise the arrangements with the banks for external project finance (depending on the circumstances in the range of 70-80% of the total costs of Phase 1). Often this also involves financial agreement with the government, e.g. for necessary “public” facilities, such as road and rail access. To reach such agreement an Economic Analysis is usually required. (Section 4.5.6)

When these preparations are completed and the government permits for Phase 1 are obtained, then the actual realisation of the project can start.

4.4 Permits and Legal framework

As described in the previous section the primary role of the government in the planning of a port (expansion) is to judge the result of work done by the initiator and to give the necessary permits as and when required by law. These permits are mostly related to social and environmental impacts of the project and to the construction of the (1st Phase of) the project. When a government also contributes financially to the project (for instance to realise public components within the overall plan) there will be a negotiation between both parties, but this has another character than a permit.

The relation between ports and the regulatory framework is not uniform worldwide: in some regions, ports tend to regulate themselves as much as possible (e.g. the Hanseatic ports in Europe), while in other regions, ports rather rely on a strong national legal framework.

For the protection and improvement of the environment, specific conventions and legislative regulations have been developed. In many cases these require legal permits to be obtained or management agreements to be implemented for both existing and proposed activities. It is important to be aware, that the legislation is constantly changing, as knowledge increases and implementation frameworks evolve.

Nowadays legal implications for European ports are in most countries governed by EU policy and EU law. The legal effects of a policy or legislative instrument very much depend on its nature. Within the EU community there are regulations that are binding and directly applicable and directives that only bind states to results that should be achieved. The states should transpose the latter into the national legislative framework which leaves a margin for interpretation. Next to that the EU uses formal decisions that are fully binding to whom they are addressed and recommendations that are non-binding. Policy documents are divided into so-called white papers that contain proposals for specific community action and green papers that are discussion papers for EU wide consultation. Examples of important EU Directives for ports are the Directive on Environmental Liability, Public Access to Environmental Information, Strategic Environmental Assessment, Water Framework Directive, Port Reception Facilities for Ship generated Waste and Cargo Residues, Birds and Habitats Directive, Nature 2000 and the Marine Strategy Directive.

Setting the scene for the national regulations are also the Global and Regional Conventions. The most important for ports are the global conventions on Prevention of Pollution from Ships (MARPOL) and Safety of Life at Sea (SOLAS) and regional Conventions like the Convention on the Protection of the Marine Environment of the North-East Atlantic (OSPAR). For information on the international rules and policies which affect the port sector, reference is made to an overview that has been prepared by the European Seaports Organisation (ESPO, 2012) .

In the Green Port concept, port authorities are proactive orchestrators which, ahead of legislation and based on stakeholder values, determine their future strategies and create

the conditions needed for the license to operate and grow. They invest in creating values that meet the demands of the future. In that case the (future) legal framework should at least recognise those needs and support these developments with appropriate legislation and regulations. For this Green Port concept, reference is made to the joint PIANC (World Association for Waterborne Transport) and IAPH (International Association of Ports and Harbours) report: Sustainable Ports, a Guide for Port Authorities. (PIANC, 2014)

Developing initiatives ahead of the regulations is the best way to have regulations in place which would be functioning from operational and societal perspectives and to avoid a cascade of sub-optimal regulations.

At the same time, it is also of great importance that port authorities adhere to existing national and supranational legislation, working together with public authorities when there is a necessity to develop this legislation in more detail. Especially when concerning nature protection and ecosystem developments, effects of measures taken are only visible in the longer term (>3-5 years). Port authorities can cooperate with public authorities to ensure that the existing legislation is developed and stabilized to allow for long term sustainable implementation. Evaluation of the legislation can take place when monitoring results are available after several years.

Around the world permitting procedures are different in their appearance, but ports could, together with the permitting authorities, pro-actively promote that the permitting instrument is transparent and includes stakeholder involvement including contractors and that the instrument is used to ensure:

1. Integrated assessment of port activities
2. Integrated monitoring and evaluation of port activities.

It should be realized that in a many situations transparent agreements with operators or the listing of requirements upfront in contracts can be very effective supporting the permitting procedures.

Some countries use or are developing umbrella permits for port areas. The opportunity of such a permit is that it can anticipate managing the activities within a certain area or in a reducing environmental space. It will also enable the area manager, e.g. the landlord port authority and the permitter to look at the area in an integrated way and assess the activities in a holistic way. It could be an effective instrument in the lease and contracting processes with regard to the clients and operators in the port. It however should not interfere with the responsibilities of the port authority and the responsibilities of the individual users of the port area. When used well it can be a welcome instrument for the landlord port manager to ensure long term sustainability and improve the transparency of the footprint of all the industrial and terminal related activities in the port area, including the footprint of its related transport processes, when supported by integrating monitoring and evaluation processes.

4.5 Technical Planning

The basic process of masterplanning is shown in Figure 4.3. After having determined the requirements of the future port or port expansion, (in terms of cargo, passengers and/or industrial development), there follows a 1st cycle with rough generation of many lay-out concepts, evaluation and selection of 2-3 most promising alternatives. These are subsequently worked out in more detail, using improved data, after which a second evaluation leads to the selection of the master plan lay-out.

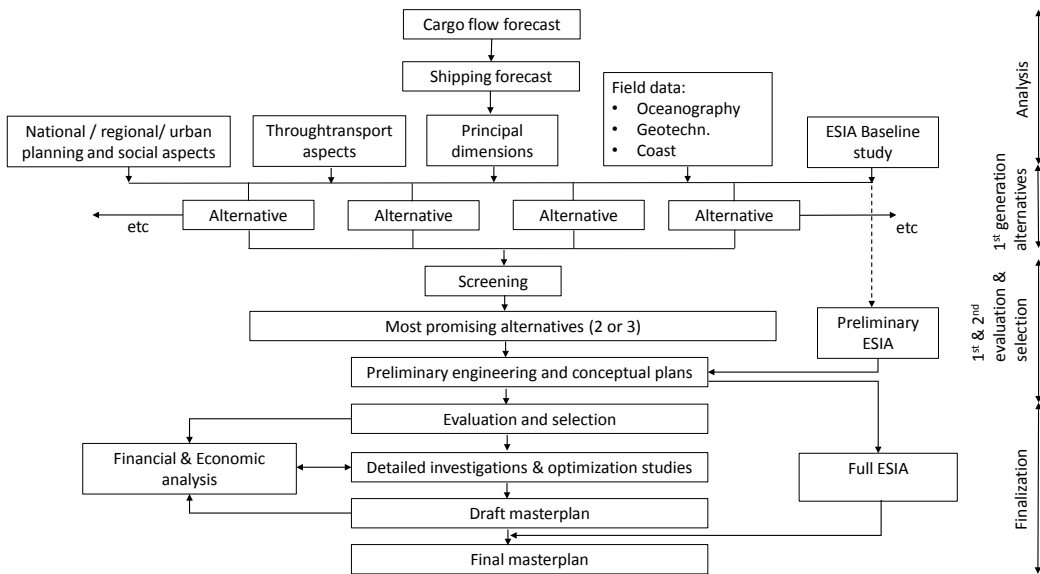

Fig. 4.3 The technical planning process

It is important to maintain balance between the accuracy of the input data and the level of detail of the design. As shown in Fig.4.3 the 1st generation of alternative lay-outs is done on the basis of available data on wind, waves, currents, bathymetry, soil, etc. Often these are not related to the specific site, but of a more general nature (and hence less accurate). Surveys may be started, but the results are not yet available. Hence the alternative lay-outs at this stage are not more than conceptual drawings, sketches, based on simple design rules. No need to work out any details as long as the principle dimensions of approach channel, turning circle, quays and terminals are properly reflected in the different alternatives. The cost assessment (because cost is an important selection criterion in all stages) is still very rough, comparing the major cost elements (breakwaters, dredging, quays). After the 1st step better input data come available and the promising alternatives are elaborated in the 2nd step. Preliminary design entails the use of applicable design standards, either national or international. The cost estimates have typically an accuracy of 30%.

In the following sections the consecutive tasks are described in more detail.

4.5.1 Cargo and Shipping Projections

Port masterplanning generally starts with a long term projection of the cargo flows that are expected to be handled in the port. These projections can either be developed as a forecast or a set of scenarios. Cargo projections are conducted by a transport economist at the beginning of the masterplan project. In view of their relevance as the basis of often very large investments, it is important to allow sufficient time for these projections.

Forecasting concerns making definite projections of expected future developments based on historical trend analysis and expert opinion. In practice forecasts are often accompanied by a low and high estimate that provides insight in the bandwidth of possible future developments. These high and low estimates are usually obtained by varying some of the primary variables, such as Gross Domestic Product (GDP) of a country or a region. When applied in this way the low and high estimates should, in fact, be regarded as some kind of sensitivity analysis indicating the bandwidth in the outcome of the forecast value. Though such low, medium and high estimates are sometimes referred to as scenarios, this is incorrect. Forecasting techniques can be used to quantify scenarios but this does not hold the other way around, because scenarios present possible – not expected – futures. It is therefore better to speak of low, medium, and high projections.

An advanced approach that is not often used but promising is the development of probabilistic cargo projections. These projections do not only indicate the expected median value, but also the expected variance. Probabilistic port projections can be prepared for both short and long term developments, though projections for longer term developments can only be made at a higher level of aggregation, because the longer the time horizon the less detail can be taken into account if one aims to maintain a reasonable bandwidth (Van Dorsser et al, 2012).

When historical data does not reveal a clear trend, major changes are expected, or in case of a greenfield development, one cannot rely on forecasting methods that merely extrapolate the historical trend. In that case one shifts to the use of scenarios. The Port of Rotterdam, for instance, uses scenarios as it recognizes major uncertainties due to, amongst others, reversed globalization, energy transition, and 3D printing. Scenarios enable us to take a long term view in a world of great uncertainty (Schwartz, 1991). They provide a framework for anticipating plausible developments and possible surprises. Scenarios are also often (ab)used to sketch a bandwidth of expected developments. In that case the port planner should keep in mind that no probabilities can be assigned to scenarios. The choice for the presented set of scenarios highly influences the anticipated developments. In case scenarios are intended to give an impression of the expected direction and bandwidth of possible outcomes it is important to assure that they are chosen carefully. In practice, scenarios are sometimes also ‘used’ as a political instrument, for instance to stress the need for a new port expansion. In such cases the port planner should be very reluctant to accommodate the full projected demand and pay much attention to the phasing of subsequent developments (e.g. only include ‘white elephants’ as last phase development in case it is insisted on by the client for political reasons).

As mentioned above forecasting methods can either be used to prepare forecasts of expected developments or to quantify a range of possible scenarios. Where it comes to the preparation of port projections three conceptually different methods can be applied, depending on the type of commodity or the activity under consideration. These are the 'top down', the 'bottom up' and the 'logistical modelling' methods. The top down method departs from the broader macro-economic development of the region (i.e. population, GDP, trade volumes, ...) and links this development to the cargo flows to/from the hinterland. The bottom up method starts with the development plans and expectations of individual companies or industries that use, or are intending to use, the port, for which it aggregates the volumes. The logistical modelling approach uses a transport model to estimate the potential cargo volumes in case changes to the broader logistical system are made, for instance when adding a new terminal in the region. These models use a global description of the cargo flows (based on origin / destination data) taking into account the existing hub and spoke lines, as well as the capacity and cost structure (i.e. price levels) of the present fleet and terminal infrastructure.

The top down method is well suited to forecast commodities that are closely linked to the general consumption and manufacturing levels in a certain region. The bottom up method is especially useful for commodities that are closely linked to specific industrial activities, such as mining or agricultural production. And the logistical method is most useful to prepare forecasts for commodities that are footloose and not necessarily linked to the port hinterland, for instance to prepare projections for transshipment containers.

Finally a comment about industrial ports. In this case the cargo volumes are a function of the type of industry. As mentioned in Section 4.2 the cargo volumes and related requirements in terms of space and berthing facilities for a captive industrial port are usually well defined by the industry. Only in case the industrial functions are part of a regional development plan (as also mentioned in Section 4.2) it is not possible to carry out cargo projections as described above. Industrial development studies are carried out to identify potential industries and collect information on spatial requirements and related cargo volumes. But such studies fall outside the scope of this chapter.

Once the cargo projections have been completed, the number and sizes of ships to carry the different types of cargo need to be determined. This requires insight into how the shipping lines will deal with the different trades that follow from the cargo projections.

The sizes and annual number of ships are needed to calculate the total berth length for various terminals. These figures are estimated by choosing the most likely range of vessel sizes for the respective trades (containers, liquid bulk, dry bulk, etc) and to divide the annual cargo throughput by the average dwt tonnage/TEU call size of that range.

4.5.2 Functional Requirements and Planning Elements

A useful document, especially for ports in developing countries, is the 'Handbook for planners' (UNCTAD, 1985). Based on the cargo projections the number and size of ships can be determined, often taking into account the existing fleets. In some cases future develop-

ments of vessel size must be assumed (such as the present trend towards larger container vessels) and occasionally a port facility is built for a specific vessel, e.g. the dedicated LNG transport service between Brunei and Japan.

Once the expected fleet composition is known the functional requirements for the port can be formulated, in terms of vessel sizes per cargo type, design vessel, number per year, transport volumes to and from the hinterland, port services, etc. The principal dimensions of the ports wet and dry areas are determined by use of design formulae, which will be treated in subsequent chapters. In this way the functional requirements are translated into planning elements:

- Dimensions of approach channel, turning circle and other water areas in the port
- Dimensions of quays for different types of cargo
- Dimensions of terminal areas
- Hinterland connections
- Number of tugs, etc. and dimensions small craft harbour
- Service areas, buildings
- Land required for industries
- Safety and environmental requirements, including safety distances for the handling of dangerous cargo

4.5.3 Site Data

Knowledge of the site conditions is an indispensable part of port planning. For the extension to an existing port this task has a different content than for a green-field port development. In the latter case the port designer has to start without data being available. Because this is the most challenging case it will be treated here. It should be recognised however that there are few green-field port developments. In most cases planning relates to expansion of existing ports and ample site data is available.

The port planner requires data on:

- Bathymetry
- Wave conditions
- Currents and horizontal tide
- Water levels and vertical tide
- River flow rates (in case of river ports)
- Meteorological conditions (wind, rainfall, fog, temperatures)
- Salinity
- Sediment characteristics and transport
- Soil characteristics and geotechnical conditions
- Seismic conditions

Some of the data have a distinct stochastic nature and require extensive periods of measurements in order to determine design parameters with sufficient accuracy. The most common example is the design wave height for design of breakwaters and other structures. To obtain a reliable estimate of for instance the 50 year return period wave condition from in-situ measurements one needs at least several years of wave recordings. Within the time frame of

a planning study this can not be realized. The question is therefore how to collect data with acceptable accuracy in a short period of time (while initiating surveys and data collection campaigns to serve subsequent stages of port development). This will be discussed below for the various types of data, including traditional sources of information and advanced methods available.

Bathymetry The first and most accessible source of bathymetric data is the nautical chart. Most seafaring countries provide charts of the coastal waters and adjacent sea areas, that are regularly updated, indicating water depths, type of seabed (sand, mud, rock, etc) and sometimes current speeds. Moreover the chart shows information on tidal elevations, in terms of MSL and mean values of high water and low water during neap and spring tide. The British Admiralty collects all this information and publishes the so-called Admiralty Charts, which can be purchased on the internet. It should be recognized that the scale and amount of detail of these charts increase around existing ports and high density traffic routes. For a green-field port site in e.g. South America, the scale may be small, but there is something to start with. In case of a full masterplan study there is normally enough time to execute a proper bathymetric survey. This is particularly important when the foreshore seabed topography is irregular and influencing the wave propagation.

Climate The British Admiralty also publishes the "Pilots", providing information for mariners on the coastal areas and port approaches all over the world (Pilot, various years). These Pilots are useful for the port planner, giving general oceanographic and climatic data on the sea or coastal area concerned. This includes:

- Wind data, including seasonal variations such as during the monsoon in South Asia
- Wave conditions, be it not in a statistical format; indication of typhoon / hurricane occurrence and their typical paths
- Current patterns and velocities, related to large circulation systems and/or tides and winds
- Temperature
- Rainfall
- Fog

The Pilot data are certainly not sufficient for port planning, but they provide a qualitative picture of the site, complementary to the Chart.

Wave conditions Until 1980 the so-called ship observations were the only source of statistical wave data available. Mariners observations of wave height, -period and -direction, taken at regular time intervals on board of all ships at sea, formed the basis of the matrices published in e.g. Ocean Wave Statistics (Hogben, N. et al, 1967). Because this method of data collection had started just after WWII, the amount of data and length of recording period were sufficient to allow extrapolation to extreme values. Yet the accuracy of the observations made was low, estimated to be not better than about 20%.

During the 1970s the development of numerical models describing the relation between barometric pressure, wind velocity and -direction and wave growth and -propagation brought great improvement. The availability of historical weather maps for the entire globe in meteorological centres such as the KNMI made it possible to *hindcast* the storms above a

certain threshold for a specific area of the oceans or seas. The peak-values of these storms could be extrapolated using theoretical distributions such as Gumbel or Weibull to obtain the extreme wave conditions needed for design.

Whereas these models were initially applied for specific areas and for storm events only, nowadays they are used on a regular basis. It is possible to obtain the wind and wave statistics from internet data bases (a.o. NOAA), for any ocean- or sea area in the world, based on *hindcast* computations. These include both operational and storm conditions and hence can be used in the port planning for down time assessment and definition of design wave height. The accuracy of these computations is estimated to be about 10%, i.e. similar to that of the in-situ measurements.

A further development is the use of satellite measurements of wave height. Since about 1985 several satellites have carried radar altimeters (e.g. ERS -1/2), each of which produced records of wave height along their track. Comparison of these measurements with *buoy recordings* have indicated an estimated accuracy of 10-15% for moderate wave conditions. The extreme wave heights (in excess of the yearly wave condition) measured by the altimeter are systematically lower by about 15%. Both factors imply severe limitations of this source for port planning: for operational conditions the information on wave period and direction is missing and for design conditions the systematic error is too large. It is expected however that the extent and quality of satellite measurements will improve.

The wave conditions described above are obtained for deep water, whereas the port location is often near shore. Translation of the wave conditions from deep water to the port location is done by means of numerical models, that represent the effects of bottom friction, wave refraction, shoaling and breaking. The model SWAN, developed by Delft University of Technology, is used worldwide and produces reliable output. For preliminary estimates, the shoaling diagrams of Goda (1985) provide an easy method to determine the wave conditions in shallow water, but with a much lower accuracy.

Tide and current conditions For the vertical tide the information presented on the Admiralty Charts is generally sufficient for the planning phase. And even when the specific conditions at the site are expected to affect the overall tidal situation (e.g. in an estuary or lagoon) one month of water level recordings is sufficient to determine the tidal characteristics. This can be realised within the scope of a planning study.

For water level set-up due to wind and waves this does not hold. The simple methods presented in e.g. the Coastal Engineering Manual (USACE, 2002), are adequate for an estimate. Regarding flow velocities the same approach is usually followed: in-situ measurements during a relatively short period of time, at least including a full spring tide and a full neap tide cycle. Extreme velocities due to river discharge are often not measured in such a campaign.

Sediment and soils characteristics The conditions of the seabed and the shallow sub-surface are important for the assessment of dredgeability and use for fill material, as well as for the design of structures. The indications on an Admiralty Chart are insufficient and need to be verified and supplemented by in-situ measurements. An effective approach is to combine the bathymetric survey with seismic profiling, which gives a reliable indication of the subsoil topography, provided that it is supplemented with a sufficient number of soil

borings to "calibrate" the seismic results. Soil sampling in the borings and subsequent laboratory test will provide the necessary information on the subsoil characteristics.

Seismic conditions A privileged part of the world's coastal areas has no historic record of seismic events and in consequence in these areas -rightly or wrongly so- earthquakes are not considered as a potential threat to the integrity of ports and port installations. In other areas earthquakes are a more or less frequently recurring phenomenon, which does have a significant influence on port site selection and subsequent design. Many earthquake-prone countries do have directives with regard to earthquake provisions in their building codes, in their simplest and inadequate form as a maximum horizontal acceleration to be taken into account in the country's different regions. For a major infrastructural investment as a port, it is strongly desirable to consult seismologists on the strength and probability of occurrence of site specific earthquakes, as these may deviate considerably from the regional average, depending on the local geological picture.

A special aspect of seismicity is the potential occurrence of tsunamis, even along coasts that are well away from fault zones themselves. Tsunamis are very long sea waves generated by sea bottom movements, and may travel over great distances without losing much of their energy. The susceptibility of a coast to tsunamis not only depends on the potential of occurrence of earthquakes in the oceans and seas within a very wide area, but also very much so on the sea bottom topography in the subject area. Desk studies can very well quantify the threat. If there is such threat, there are no port planning solutions that can eliminate the problem, but design-wise much damage due to seismic events can be avoided (PIANC, 2001).

4.5.4 Layout Development

This task had been mentioned before as the creative part of port planning. The planning elements have been prepared and must now be pieced together into a lay-out. Several lay-outs in fact, because many different solutions are possible. While the planning elements have been determined on the basis of formal design rules or guidelines, that are treated in the following chapters, making the lay-out does not follow formal rules. The specific local conditions play a dominant role and therefore no port lay-out is similar to another one. There are a few do's and don'ts, which should be kept in mind however, such as:

- i. Construction cost is an important factor in the feasibility of the port and can most strongly be influenced in this conceptual stage of lay-out development (once the lay-out is fixed, the possibilities for cost optimisation are very limited). When the port is located at the coast a balance of cut and fill is often the best solution, unless the soil is very hard (high dredging costs) or very soft (dredged material unsuitable for reclamation), see Figure 4.4. Also the length of breakwaters should be minimised as these form an important cost factor.

4 Port planning methodology

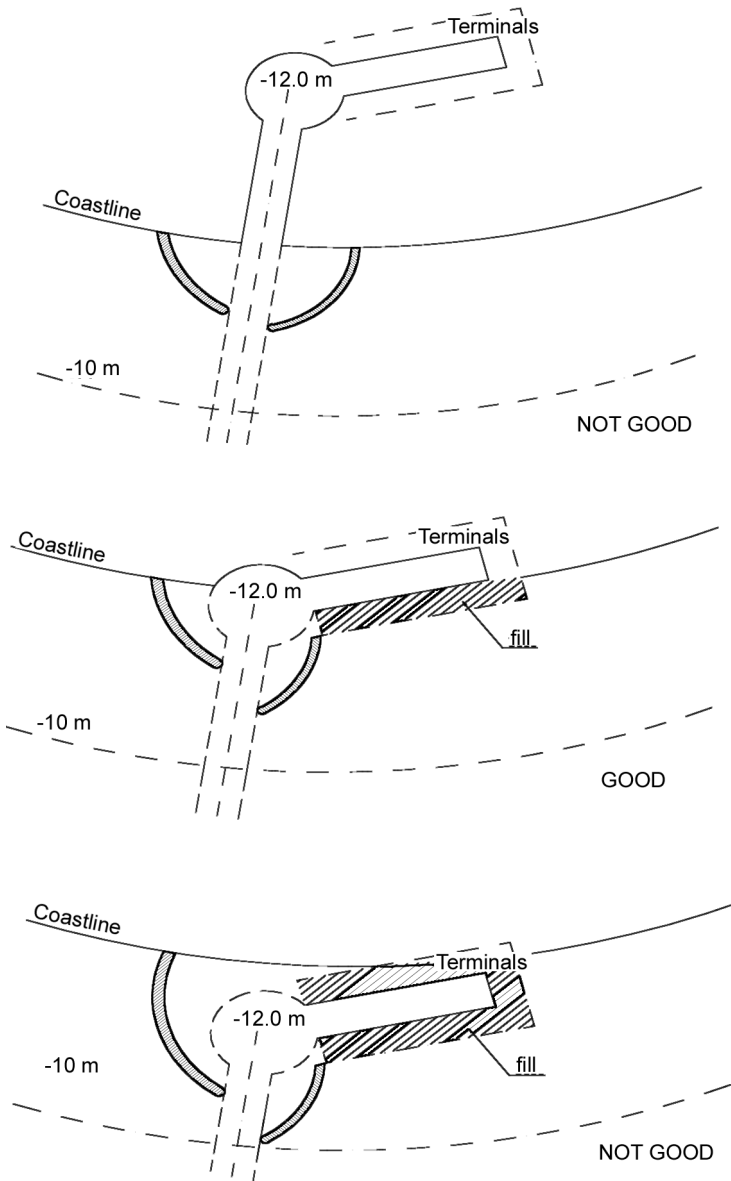

Figure 4.4 Balance of cut and fill

- ii. In case of strong offshore wave conditions the orientation of the approach channel should preferably be in line with the dominant wave direction in order to have waves coming in aft of the vessel instead of quartering or beam. Beam wind and waves increase the vessels drift angle, which may induce the bridge team to increase speed. The former effect leads to larger channel width, while the latter influences the stopping distance and may lead to longer breakwaters (see Section 5.4). At the same time the configuration of the entrance channel and breakwaters should limit wave penetration and hence the downtime for (un)loading operations in the port. In many circumstances these two requirements are in conflict

with each other and will require a compromise, whereby the channel axis has an angle of max 30° with the main wind/wave direction, which is sufficient to cause the incoming waves to diffract first behind the outer breakwater head and once more behind the second head. (see Figure 4.5). Obviously a final solution requires vessel manoeuvring and wave penetration modeling during the design stage.

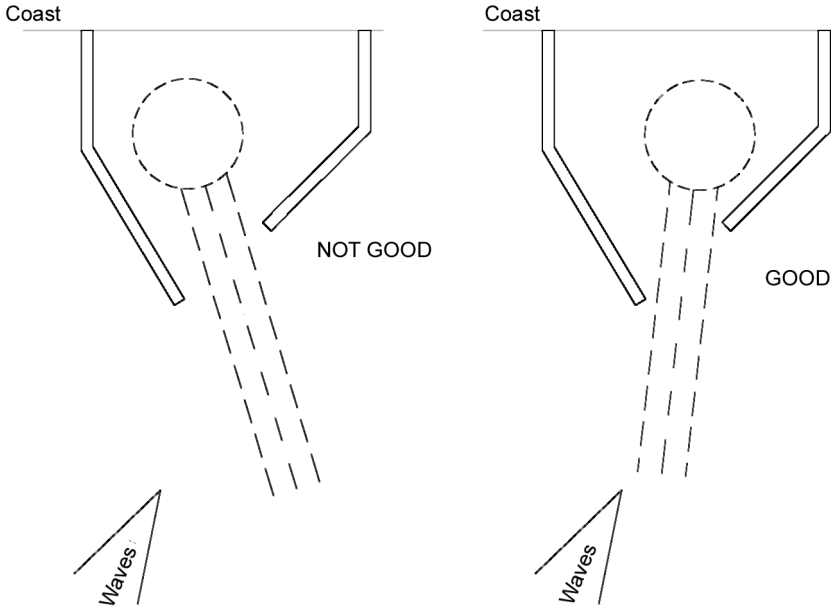

Figure 4.5 Orientation approach channel with respect to wave direction

- iii. When the port basins and entrance channel are protected by breakwaters these should not form a narrow "sleeve", but provide space immediately behind the heads (see Figure 4.6), for three reasons: 1) ships manoeuvring in a channel do not like a hard structure close to the channel boundaries, 2) when there is a cross-current along the entrance, vessels need lateral space in passing from the current into still waters, and 3) open space behind the breakwater heads helps the diffraction effects and thus reduces wave penetration. It is seen from Figure 4.6 that the net breakwater length in b) is not increased compared with a), while the open lay-out also provides a lot more space inside the port for future development.

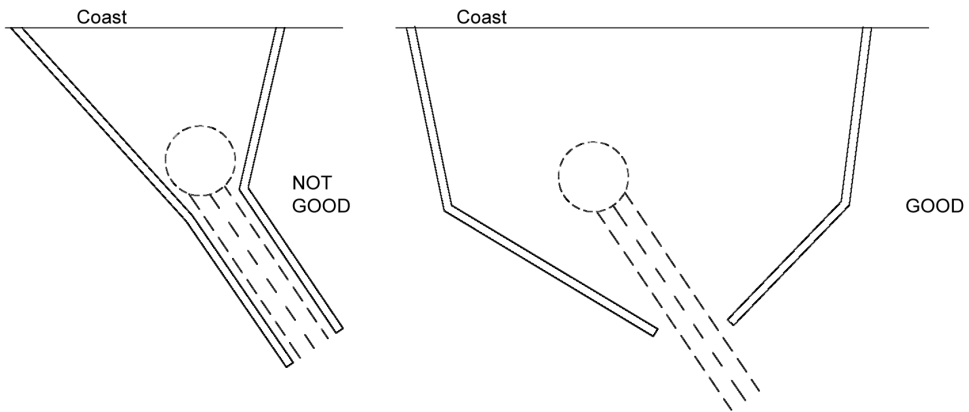

Figure 4.6 Breakwater alignment

- iv. Bends in the approach channel close to the port entrance or immediately behind it should be avoided: the vessel needs a straight course without the complications of steering through a bend.
- v. Then there are morphological effects to be taken into account. Without going into detail in this section, three basic principles are mentioned:
 - a. Along the alluvial coastline the littoral transport occurs inside the breaker zone. Breakwaters should therefore reach beyond to the corresponding water depth in order to avoid this sediment transport to deposit inside the approach channel.
 - b. When littoral transport occurs in both directions along the coast, breakwaters are also needed on both sides. Only when the wave climate is such that the littoral transport is unidirectional one breakwater may suffice.
 - c. The length of the breakwater depends not only on the extent of the breaker zone but also on the magnitude of the littoral transport and the corresponding accretion rate at the breakwater.
- vi. Regarding the location of berths and terminals some general safety aspects can be formulated:
 - a. There should be no berths or hard structures in the stopping line of the vessels, also not beyond the turning circle. In case a stopping manoeuvre fails the vessel should be able to run aground in a soft bank.
 - b. Liquid bulk terminals preferably have to be located downwind from other port activities and certainly from urban centres. In case of an accident the negative effects (smoke, toxic gases or a vapour cloud) will thus have less impact.

4.5.5 Project Evaluation

As mentioned before evaluation of lay-out alternatives takes place at different stages of the planning process: first screening of rough sketch lay-outs, followed by evaluation of the most promising alternatives, and finally an analysis of the financial and economic feasibility of the selected masterplan lay-out. The evaluation techniques become more elaborate

in subsequent stages, as the level of detail increases throughout the project. A complicating factor is that the criteria for evaluation are very different in nature and importance, varying from nautical safety to noise nuisance. Moreover the value assigned to them also varies among the stakeholders. This section starts with a discussion of available evaluation methods that can be applied to all stages of the masterplan, and continues with a specific discussion on the usual approach for evaluating the preliminary port lay-outs.

Evaluation techniques

The evaluation of the masterplan can be based on non-monetary and monetary evaluation methods. These methods have in general that they aim to quantify the effects over time. The difference is that non-monetary methods ascribe the quality of the plan (with regard a specific aspect of it) by a score, while monetary valuation methods convert these assessments into money values (i.e. expressed in a certain currency, for instance US\$ or Euros). A common used non-monetary evaluation method is the Multi-Criteria-Analysis (MCA). Monetary methods are the (commercial) cost benefit analysis (CBA) that is also called financial analysis, and the social cost benefit analysis (SCBA) that is also called economic analysis. Multi-Criteria-Analysis (MCA) concerns a kind of assessment that applies different weights to different aspects to assign an overall value to the project alternatives. MCA can be used as a very simple tool for assessing various aspects in the preliminary design stage, but also as a rather advanced tool that deals with the valuation of a broader range of policy aspects for which it is very difficult, or impossible, to quantify the effects and/or express them in terms of money (Department for Communities and Local Government, 2009). MCA is also useful to deal with situations where different stakeholders assign a different value to the effects.

The financial and economic analysis can also be seen as evaluation tools, but are generally only applied after selection of the basic masterplan lay-out, as shown in Fig. 4.3. These analyses are treated in detail in Section 4.5.6.

Usual approach for evaluating preliminary port lay-outs

For the evaluation and selection of the preliminary port lay-outs one normally applies a relatively basic MCA. The principle of MCA is that a proposed option is evaluated for a number of criteria, which can differ in importance. Such differences are expressed by giving “weight” to the criteria, by which the evaluation scores are multiplied. For the evaluation of a preliminary port design it is common to use a framework that contains a set of primary, secondary and tertiary criteria, each of which is given its own weight.

The primary criteria can be set by a panel, representing all the disciplines involved, using an iterative process. The secondary and tertiary criteria which are sub-divisions of the primary ones, can be set by representatives of the various disciplines in question. In MCA the alternative solutions are given scores for all criteria. Multiplication of the scores by the weight results in an overall score for the proposed option that can be compared with the score for other options. The MCA method has the disadvantage of substantial subjectivity in setting the weights, but the entire calculation is repeated easily with different weights to investigate the sensitivity of the outcome for the determined weights.

4 Port planning methodology

In the past “costs” (or in fact better to speak of expenditures) were one of the criteria, that were treated like all other aspects. Nowadays a different approach is often chosen, whereby all non-cost related criteria are treated as “value” and all “cost” items are summed up. The comparison and selection of alternatives is now made on the basis of the highest value over costs ratio. The advantage of this method is clear. A slightly higher cost level may be justified, if the value of the alternative is better.

An example of a score table for the assessment of preliminary port designs based on the MCA method is presented in Table 4.1. In this specific example the weight of the primary criterion equals the sum of the weights of the corresponding secondary criteria, which in turn are summed up from the tertiary ones. The extent to which criteria are refined depends on the level of detail reached in the project.

Table 4.1 Example of an MCA score table

primary criteria	weight	secondary criteria	weight	tertiary criteria	weight				
port technology	22	nautical and hydr.	10	approach route	1				
				stopping length	3				
				manoeuvring space	1				
		flexibility	5	construction aspects	7	nautical safety	2		
						wave penetration	3		
						extension poss.	3		
						re-allocation berths	2		
spatial planning	5	flexibility	5	building time	3				
				phasing poss.	4				
env. aspects	8	aquatic env.	2	etc.					
				coastal morphology	2	noise	2		
						dust	2		

4.5.6 Financial and economic analysis

For port development it is common to assess the financial feasibility for the (private) investor by means of a (commercial) cost-benefit-analysis (CBA) – and to assess the overall effect on society by means of a social-cost-benefit analysis (SCBA). In port masterplanning the commercial CBA is normally referred to as the Financial Analysis. The SCBA is often referred to as Economic Analysis, depending on who requests the analysis. The term SCBA is common for governments that are used to the method as a policy instrument, such as the Dutch and British government. The term Economic Analysis is common for assessments required by International Financing Institutes, such as the World Bank and the Asian Development Bank.

Cost Benefit Analysis / Financial Analysis

Basic principles

The CBA, or financial analysis, is a method for evaluating the merits of a particular project in a systematic and rigorous way. The CBA method is relatively easy to conduct as it only requires the expected cash flow for the investor as input. The expected cash flow consists of the capital expenditures (CAPEX), operational expenditures (OPEX), and revenues in each period throughout the duration of the project (e.g. on an annual basis throughout the duration of a concession). For port investment projects the cash flow is typically as indicated in Figure 4.7.

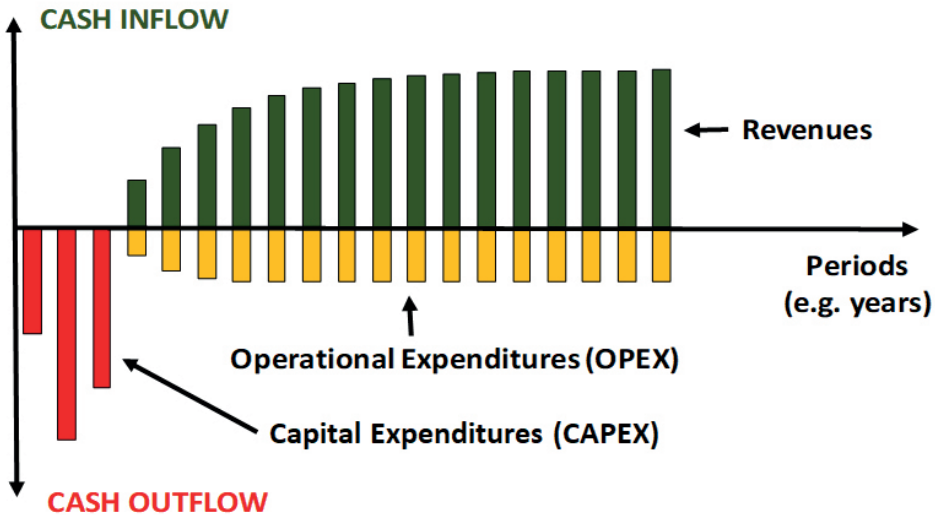

Figure 4.7 Typical example of a port investment cash flow

In order for a project to be feasible the revenues need to be larger than the expenditures, but one cannot simply add-up the expected cash flows without compensation for the time value of money. Economists apply discounting techniques to take into account the fact that the value of money differs over time. When money is invested it generates a certain return on investment. For companies with alternative investment opportunities that provide an R percent annual rate of return, 1 money unit today is worth $1+R$ money units one year from now. In a similar way a 1 money unit one year ahead is worth $1/(1+R)$ units today.

By applying future discounting the entire project cash flows can be represented by a single number, that is called the Present Value (PV). If the discount rate is kept constant over time, which implies that the required returns on capital are assumed to remain constant over time, the formula for calculating the present value of the cash flow at the beginning of the project is as follows:

$$PV(CF)_0 = \sum_{t=0}^{t=\infty} \frac{CF_t}{(1+R)^t} \quad (4.1)$$

in which:

- $PV(CF)_0$: present value of a cash flow at $t = 0$;
 CF_t : cash flow at time t ;
 R : the applied discount rate;
 t : number of time periods ahead.

Though the project will not run forever, the infinity sign in the summation indicates that all relevant future cash flows are taken into account. Cash flows beyond the end of the project are zero and therefore have no effect on the present value.

A complicating factor in the CBA is the existence of inflation. Inflation has a significant effect on the outcome of a cash flow analysis. Economists therefore distinguish between the nominal and real value of money, which are defined as follows:

- Nominal value: monetary value expressed in money of the actual time being (e.g. the nominal value of a 100 euro bill is 100 euro today, and 100 Euro at any other point in time, but what you can buy for it differs over time).
- Real value: value in terms of goods. It is adjusted for changes in general price levels and expressed in currency units of a certain base year (e.g. in purchasing power of Euros at constant year 2016 price levels).

With respect to dealing with inflation one has two options. The first option is to work with nominal values and include inflation in the cash flow. This implies that one has to make projections of the expected inflation levels (that may be different for various expenditure and revenues items). When nominal values are used the discount rate should include an inflation component. The second option is to work with real values that are expressed in constant price levels of a certain base year. The relation between the nominal discount rate R and the real discount rate r is shown by Equation 4.2:

$$R = (1 + r) \cdot (1 + i) - 1 \quad (4.2)$$

in which:

- R : nominal discount rate;
 r : real discount rate;
 i : rate of inflation.

To give an example: suppose that an investor requires a nominal return on capital of 15% and that this required return is defined for operations in a market with a 3% annual inflation (e.g. the present inflation level). In that case the nominal discount rate is 15% and the real discount rate can be derived as $(1+15\%)/(1+3\%)-1 = 11.65\%$.

Note that only in case of small values for i and r , the nominal discount rate is approximately equal to the real discount rate plus the rate of inflation. This no longer holds for larger

values. In the above example the approximation would be 12%, which is 0.35% higher than 11.65%. Use of this approximation is therefore not recommended.

Defining the appropriate discount rate is generally one of the more complicated aspects of the CBA or Financial Analysis, that will be discussed in further detail below. If one is uncertain about the discount rate it is good practice to apply a sensitivity analysis, that indicates the sensitivity of the project feasibility to the discount rate. This is important because the impact of the applied discount rate on the project feasibility is substantial.

The last step of the financial analysis is to derive performance indicators in order to judge the feasibility of the project. These indicators are based on the CAPEX, OPEX, and revenue flows, as well as on the applied discount rate. Common indicators for the evaluation of the financial feasibility are the:

- Net Present Value (NPV): the sum of the present values of incoming and outgoing cash flows over a period of time;
- Internal Rate of Return (IRR): the discount rate at which the Net Present Value of the project is zero;
- Benefit Cost Ratio (BCR): present value of the benefits divided by present value of “costs” (note that one means expenditures instead of cost);
- Payback Time: the period that it takes before the cumulative revenues are larger than the cumulative expenditures.

A project is feasible when it has a positive NPV. In finance this is called the NPV rule. The IRR represents the discount rate at which the NPV becomes zero. A feasible project should have a Financial-IRR (FIRR) that is higher than the applied discount rate. Likewise, a feasible project should also have a BCR that is greater than 1, as a project can only have a positive NPV when the present value of the benefits outweigh the present value of the “costs”. The payback time indicates the time that it takes for a project to regain its expenditures in nominal terms. A useful variation on the payback time is the discounted payback time, that shows the minimum time the project requires to become feasible, which may for instance be interpreted as the minimum required duration of a port concession.

Financial models

The financial analysis is not only important to judge the financial viability of the project once the masterplan is completed, but also as a design tool for optimizing the port masterplan during the design stage. When developing a financial model one has to decide whether the analysis is made at the overall project level or at the level of the investor. A financial analysis that is conducted at the project level assesses the returns on the total invested capital, which include both debt (borrowed money) and equity (own money provided by the investor). A financial analysis that is conducted at the level of the investor assesses the effects on the invested capital provided by the investor (i.e. equity cash flow).

The benefit of conducting a financial analysis at the project level is therefore that one does not have to include finance (debt structure), depreciation, and tax payments over time – and that the financial model can be prepared in real terms, which means without inflation. The

latter is not possible for a financial analysis at the level of the investor, because inflation increases costs and revenues (assuming that revenues are adjusted for inflation) and thereby affect the debt structure, bookkeeping profits, tax levels and dividend payments. So a financial analysis that assesses the returns on equity for the investor is clearly more complicated than a financial analysis that assesses the returns on the total invested capital.

Due to the difference in scope of financial models at the project level and at the level of the equity provided by the investor, a more specific naming is required. It is common to specify the model by using the following prefixes: nominal/real, pre/post-tax, and pre/post-finance. The prefix nominal/real indicates whether inflation is included in the model or not (nominal: with inflation; real: without inflation). The prefix pre/post-tax indicates if tax payments are included. The prefix pre/post-finance indicates if the finance structure (loan drawdown, interest payments, and principal repayment) is included in the model. Though these three prefixes could in theory result in 8 different types of models, in practice only two of them are relevant, which are the:

- (Simpler) real pre-tax pre-finance financial analysis, that indicates the overall profitability of the project for the total invested capital;
- (More complex) nominal post-tax post-finance financial model, that indicates the profitability of the project for the capital provided by the investor.

For the evaluation of design decisions during the technical design and optimization phase of the masterplan, the use of a real pre-tax pre-finance financial model (i.e. at the project level) is generally sufficient, which simplifies the analysis substantially. For the final evaluation of the masterplan at the end of the project, or at least when moving towards the stage of arranging the funding, a more complicated nominal post-tax post-finance financial model is required, that defines the equity cash flow for the investor.

A sensible approach to financial modelling is to stage-wise develop the model throughout the project. Step 1 starts with preliminary CAPEX and OPEX estimates that are used to define the present value of the costs that feed into the MCA at the end of the preliminary design stage. Step 2 concerns the development of a (simple) real pre-tax pre finance financial model during the optimization of the project for financial performance. For example by adding additional phasing options. The last stage concerns upgrading the model to a (more complex) nominal post-tax post-finance financial model.

Discount rate

Having discussed the use and structure of the financial model, the last aspect that needs to be addressed is the selection of the appropriate discount rate, which is more difficult for the simpler real pre-tax pre-finance models than for the more complicated nominal post-tax post-finance models, as will be explained below.

The common way to define the discount rate in the simpler financial models at the project level is to base it on the weighted average costs of capital (WACC). With respect to the WACC it is essential to understand that, unlike the name suggests, the WACC is not a cost, but a weighted average of interest rates on debt (R_d) and required return on equity (R_e).

The options to determine the discount rate depends on the situation. If a port development plan is undertaken by a large company, for which the new development has only a marginal effect on the company's financial structure, one can apply the present WACC structure of the company. In case the capital expenditures of the project have a substantial effect on the balance sheet of the investing company, or in case a new company is created for the project, a different method is required to define the discount rate. In this case the discount rate is defined by a financial expert, who bases its analysis on the international risk free interest rates, the relative risk level of the project and the country concerned and the applicable finance structure.

For the more complicated nominal post-tax post-finance financial analysis, that is made to evaluate the returns on equity for the investor, a different approach is required to define the discount rate. For this model the discount rate can no longer be based on the WACC, as the WACC includes a remuneration for debt, whereas the nominal post-tax post-finance financial analysis addresses the equity cash flow of the investor (that does not include debt). The appropriate discount rate for this model is ideally based on the expected returns from alternative investment options for the concerned investor, adjusted for the differences in the perceived relative risk levels.

Social Cost Benefit Analysis / Economic Analysis

The social-cost-benefit-analysis (SCBA), or economic analysis, has a similar structure as the CBA / financial analysis, but does not merely base the outcome on the profitability for the investor, but rather on the broader benefits to the country as a whole. For port development projects these benefits usually include aspects such as:

- Reduced overall transport costs to/from the country compared to the situation without the new port development;
- Reduced waiting times of vessels, at least to the extent that these result in lower international transport tariffs (if it concerns international shipping lines);
- Reduced costs of terminal operations due to enhanced efficiencies and increasing economies of scale;
- Reduced hinterland transport costs as a result of improved hinterland connections;
- Fewer maintenance on existing infrastructure networks for which traffic intensities are decreased due to the new port development;
- Time savings for goods underway, resulting in lower inventory costs;
- Improved import/export capabilities due to lower costs for transporting goods, strengthening the country's competitive position on the world market;
- Stimulation of economic development related to the port sector, as well as spin offs to other sectors by means of multiplier effects;
- Effects on employment for domestic people;
- Environmental improvements, fewer emissions, fewer accidents.

The objective of the economic analysis is to define the overall (dis)benefit for the national economy (or region for which the analysis is made). This is done by first defining the "status quo", which is generally defined as the "without-project" situation. For each of the relevant project alternatives then a comparison is made between the performance in the

situation with and without the project. The economic cash flow of the project is defined by the CAPEX and OPEX as well as by the difference in (dis)benefits between the project alternative and the “status-quo”.

To reduce subjectivity and increase comparability of economic analyses governments have prepared clear guidelines (US EPA, 2010 and British Treasury, 2014). These guidelines specify how to conduct the analysis, how to value the effects, and what discount rate to apply. These guidelines also indicate that it is good practice to report issues that cannot be quantified in physical terms, or for which monetary evaluations are lacking, as one has to inform the policy maker as good as possible to enable him to take these aspects into consideration for his decision. Fundamental to the concept of economic analysis is that the effects are measured in terms of increased consumer welfare. Consumer welfare is measured by means of the surplus between the price of a certain “good” and the amount that consumers are willing to pay for it, as illustrated by the supply and demand curves in Figure 4.8.

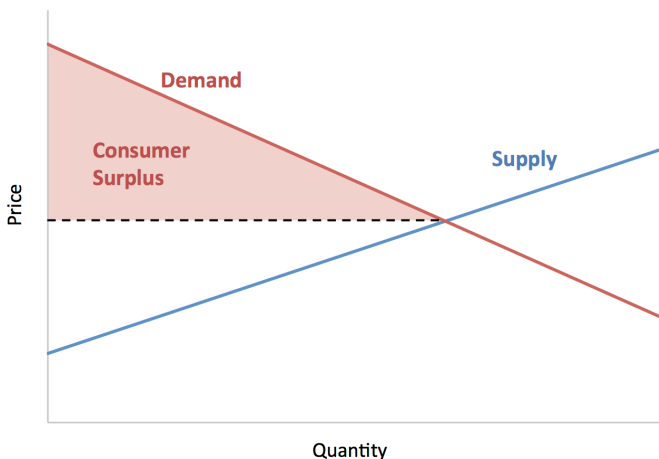

Figure 4.8 Definition of consumer surplus

The demand curve in Figure 4.8 indicates the willingness of consumers to buy a certain “good” at a certain price level, while the supply curve indicates the willingness to supply the scarce “good”. The dotted line indicates the price level at which supply and demand are in economic equilibrium. For consumers that buy the “good” the willingness to pay for it is higher than its actual price, though the amount that consumers are willing to pay differs per consumer. It varies from a substantial amount for consumers at the left side of the demand curve to almost nothing for consumers with a willingness to pay close to the equilibrium. The difference between the price that consumers are willing to pay and the market price is called the consumer surplus. For a linear supply and demand curve the consumer surplus has a triangular shape.

The effects in the economic analysis are quantified by means of their effect on consumer surplus. For example, suppose that a country imports only one type of “good”, and that

the development of a new port lowers the overall costs for supplying this “good” at the domestic market by a certain amount. The domestic supply curve will then shift downward by the price reduction that is made possible by the new port development, which results in a new equilibrium between supply and demand on the curve, as is indicated in Figure 4.9.

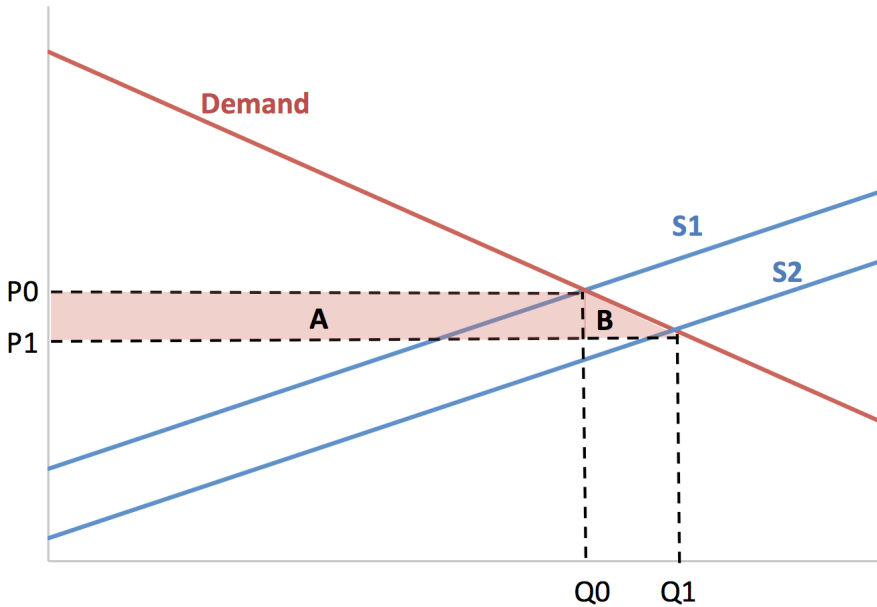

Figure 4.9 Effects of new port on consumer welfare

As a result of this new port development the existing customers of this concerned “good” are paying less by an amount similar to the difference between P_0 and P_1 . The gain in customer surplus for the existing customers is therefore similar to the product of the reduced price ($P_0 - P_1$) and the quantities that they consume (Q_0), as indicated by shaded area A. But this is not the only welfare gain. As a result of lower price levels, the consumption of this “good” has also increased from Q_0 to Q_1 , as indicated by shaded area B. For this part the gain in consumer surplus is similar to half the product of the difference in price and quantity, as the surplus on the first additional item sold is almost similar to the price difference, whereas the surplus of the last additional item is almost zero. The welfare effect of the new port development on consumer surplus is therefore:

$$\Delta CS = Q_0 \cdot (P_1 - P_0) + 1/2 \cdot (Q_1 - Q_0) \cdot (P_1 - P_0) \quad (4.5)$$

in which:

- ΔCS : Change of consumer surplus;
- Q_0 : Quantity in initial situation;
- Q_1 : Quantity in new situation;
- P_0 : Initial price level at domestic market;
- P_1 : New price level at domestic market.

Eq. 4.5 is generally simplified into Eq. 4.6, which is called the rule of half as only half of the price difference for the additional volume is to be included.

$$\Delta CS = 1/2 \cdot (Q_1 + Q_0) \cdot (P_1 - P_0) \quad (4.6)$$

In a world without taxes and perfect competition (i.e. no profits) Eq. 4.6 would be sufficient to estimate the overall welfare effect, but in reality further adjustments need to be made to incorporate the changes in the profit flows towards the domestic owners of the companies that provide port services (e.g. via dividend payments) and the government (e.g. via corporate taxes). These items need to be included as they also contribute to the national economy indirectly, which makes the analysis more complex.

A further complication is that the economic analysis does not only cover effects that are measured in terms of money, but also effects that are measured in other physical units, such as health effects due to e.g. reduction in the emission of exhaust gasses. For these effects the main challenge is to identify the potential benefits, quantify them, and express them in terms of money. This is a complicated task that often requires subjective input. Economists have conducted substantial research on how to value economic effects, for which they prefer to use revealed- and stated preference methods. For negative external effects they also use avoidance costs as an alternative second best approach.

The “cost” side of the economic analysis differs from the financial analysis, because the expenditures need to be expressed in terms of economic opportunity costs instead of in market prices. This, amongst others, implies that domestic wealth transfers, such as due to profits of domestic owned companies and domestic taxes should not be included in the CAPEX and OPEX statements. One can therefore not simply copy-paste the CAPEX and OPEX statements from the financial analysis into the economic analysis.

Unlike the financial analysis, the economic cash flow of all “costs” and benefits in the economic analysis are defined as differences compared to the “status quo”.

The economic analysis is conducted in real terms and the real discount rate is usually prescribed by the national government or by the international finance institute that demand the analysis.

All in all defining the right economic “costs” and benefits is a complicated activity that requires specialist input from an economist. This section addressed the basic principles of the economic analysis. For a more profound discussion on how to conduct an economic analysis reference is made to Belli et al (1998).

4.5.7 Project Optimisation

Following evaluation of alternative lay-outs and the selection of the most suitable one, the optimisation of the project can take place. This comprises technical and financial optimisation with the aim to achieve a masterplan lay-out, its phasing and financial parameters that are acceptable for the project initiator and the banks which need to provide (part of) the finance.

Technical optimisation

The technical optimisation includes, amongst others, the determination of and the final decision on the principal forms and dimensions of the port: access, entrance, primary manoeuvring space, number of service points (berths or quay length), terminal areas, etc. The most important goal is to minimise the expenditures (construction costs and operational expenditures), but it is not uncommon that the improved data base and more detailed computations lead to cost increases.

The tools and exercises used include computations, hydraulic model studies, navigation simulator studies, operation simulation models, with as an ultimate target the minimisation of costs. The tools are briefly described here, but are treated in detail in Chapter 5.

- i. Hydraulic model study, physical or mathematical
Breakwater alignment and wave penetration, current patterns, sediment transport, siltation and erosion, breakwater stability and, possibly, ship motion analysis.
- ii. Navigation simulation studies
Adapting the lay-out of the port and its approaches to optimise the nautical safety. Various systems exist, from complete fast-time computer models, including a programmed navigator (quick, cheap, but with limited possibilities) to full-scale real-time bridge simulators (with human navigators, ship's bridge, outside image, radar display, etc.)

Generally speaking, navigation simulator studies are more suited for a study of the nautical aspects than hydraulic model tests because they give a better reproduction of the steering effects. These usually play a greater role than the effects of the local physical surroundings, as sea bottom and channel changes (which in their turn can be more faithfully reproduced in a physical model). In most cases, both arrival and departure manoeuvres will have to be investigated. The departure manoeuvre mainly to verify if there is sufficient rudder control on leaving the shelter of the port under more severe current, wind and wave conditions.

In all cases, sufficient simulator runs will have to be made to obtain a statistically reliable picture of deviations from the channel axis and of stopping distances actually used.

The ultimate objective is the verification and optimisation of the form and dimensions of the port with respect to the approach channel, entrance and manoeuvring areas by means of risk analysis. Also to study e.g. the possibility of a reduction of the channel width as a result of the introduction of advanced aids to navigation and/or VTS systems.

- iii. Computations
E.g. with regard to the optimum depth of the ports approaches, taking into account 'tidal windows' for the maximum size vessels, the wave climate and vessel response, and a certain accepted probability of touching channel bottom.

iv. Logistic simulation models

Study of the effect on ship waiting times of alterations to, inter alia:

- the number of berths or length of quay in the port
- vertical tidal window
- horizontal tidal windows
- one/two-way traffic
- various services: tugboats, pilotage, etc.
- priority rules, safety procedures

Financial optimisation

In addition to the technical optimisation, the plan also needs to be optimised for its financial performance. Optimising for financial performance means optimising the net present value of the cash flow. Minimising expenditures is only one out of five options to improve the financial feasibility of a port project. In order to obtain a feasible Business Case and improve the value of the project four other options should also be explored. The five possible options to improve the project feasibility are indicated in Figure 4.10.

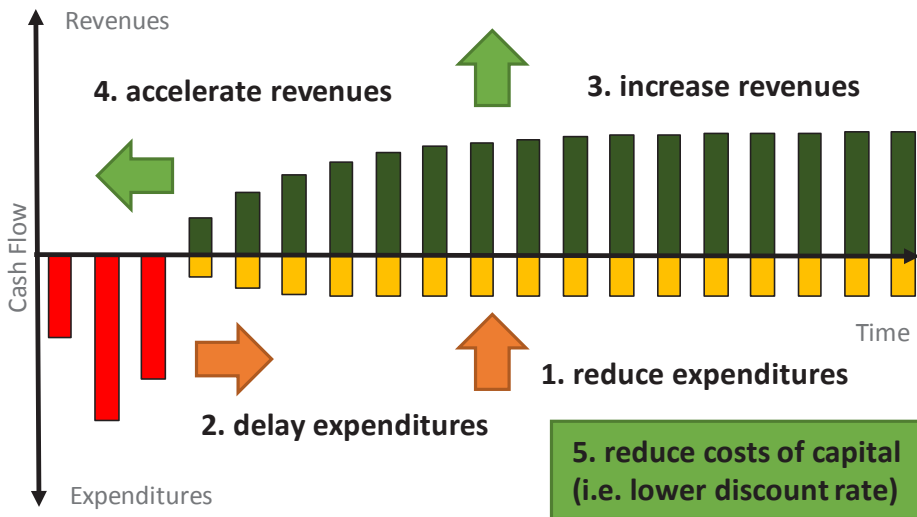

Figure 4.10 Five options to improve financial project feasibility

While developing a masterplan the port planner should not only focus on reduction of cost. Equally important is to think of options to postpone expenditures, which in practice means that one has to define options for phased development. Especially in case of high required returns the impact of phasing can be larger than the impact of cost reductions. The early start of revenues is also of major importance, due to the applied discount rate. In fact, the first few years of an operation have the largest impact on the overall financial performance of the project (i.e. on the NPV). By making services available earlier it may become possible to accelerate the revenue flow, which often justifies a higher CAPEX. Increasing revenues is also important. In this respect an interesting solution could be to involve a broader range of stakeholders, and to identify the opportunities to create broader economic value

for which someone is willing to pay. The project may also benefit from early involvement of stakeholders when it reduces stakeholder resistance and speeds up the process. The last option to improve the financial results is to decrease the costs of capital. Capital costs can be reduced by lowering the risk level of the project, because lenders are typically risk averse and demand a higher interest rate for higher risk levels. Risk levels can, for instance, be decreased by negotiating long term contracts with future port users.

To avoid the preparation of a, from a financial point of view, dysfunctional design it is important to start with financial analysis early in the project. Decisions on financial optimization principles can be made by using a simplified real pre-tax pre-finance financial model as design tool (see Section 4.5.6).

Today's port development practice is mainly driven by the Business Case for the investor, but there are signs that the development process will gradually become more sustainable and stakeholder inclusive in the future. Incorporating stakeholder values may, as such, increasingly play a role in the port masterplanning process. If ports are developed with the broader objective to create economic value for the country, not only the financial performance is important, but also the economic benefits may be analysed and optimised. This can be done by developing an economic model and by using it as a decision support tool for optimising the design (in a similar way as one now uses the financial model to optimise the design). Such an approach is also highly recommended in literature on economic analyses. Belli et al (2001) for instance indicate that: *“Economic analysis is most useful when used early in the project cycle to identify poor projects and poor project components. If used at the end of the project cycle, economic analysis can only help determine whether to proceed with a project or not”*. The use of the economic analysis as a tool for improving the proposed policy is also suggested in the Dutch guidelines for conducting a SCBA (Romijn et al, 2013).

4.6 Sustainable port development

In spatial planning and development a paradigm shift is increasingly being embraced. Truly changing the traditional engineering approach into a holistic approach in which the ecosystem is leading and values for people, profit and planet are interdisciplinary integrated. Inspiration can well be taken from the Sustainable Development Goals (SDG's) which were published in 2015 by the United Nations, as a part of its 2030 Agenda for Sustainable Development. 17 SDGs encompass a very broad range of interests, values, and objectives.

Box : United Nations Sustainable Development Goals

- Goal 1. End poverty in all its forms everywhere.
- Goal 2. End hunger, achieve food security and improved nutrition and promote sustainable agriculture.
- Goal 3. Ensure healthy lives and promote well-being for all at all ages.
- Goal 4. Ensure inclusive and quality education for all and promote lifelong learning.
- Goal 5. Achieve gender equality and empower all women and girls.
- Goal 6. Ensure availability and sustainable management of water and sanitation for all.
- Goal 7. Ensure access to affordable, reliable, sustainable and modern energy for all.
- Goal 8. Promote sustained, inclusive and sustainable economic growth, full and productive employment and decent work for all.
- Goal 9. Build resilient infrastructure, promote inclusive and sustainable industrialization and foster innovation.
- Goal 10. Reduce inequality within and among countries.
- Goal 11. Make cities and human settlements inclusive, safe, resilient and sustainable.
- Goal 12. Ensure sustainable consumption and production patterns.
- Goal 13. Take urgent action to combat climate change and its impacts.
- Goal 14. Conserve and sustainable use the oceans, seas, and marine resources for sustainable development.
- Goal 15. Protect, restore, and promote sustainable use of terrestrial ecosystems, sustainably manage forests, combat desertification, and halt and reverse land degradation and halt biodiversity loss.
- Goal 16. Promote peaceful and inclusive societies for sustainable development, provide access to justice for all and build effective, accountable and inclusive institutions at all levels.
- Goal 17. Strengthen the means of implementation and revitalize the Global Partnership for Sustainable Development.

The connection of the SDG's with port development and operations varies from weak to strong, the latter applying to SDG's 7,8,9,14 and 15.

The report 'Sustainable Ports a Guidance for Port Authorities' illustrates this shift towards an integrated and sustainable approach for the port sector. It is a joint report of PIANC and IAPH (International Association of Ports and Harbours) (PIANC, 2014). It defines a sustainable port as:

“A sustainable port is one in which the port authority together with port users, proactively and responsibly develops and operates, based on an economic green growth strategy, on the working with nature philosophy and on stakeholder participation, starting from a long term vision on the area in which it is located and from its privileged position within the logistic chain, thus assuring development that anticipates the needs of future generations, for their own benefit and the prosperity of the region that it serves.”

Key elements of the vision presented in the report are:

- Sustainability should be seen and valued as a key economic driver
- Develop a strong and clear long-term vision
- Transparent stakeholder participation and approved strategies to operate and grow the port.
- Actively sharing knowledge with other ports and stakeholders.
- Continuously striving towards innovation in process and technology.

Ports are located on waterfronts, coasts, estuaries or rivers. And many ports are interconnected to urban and industrial areas. The interactions of transport system, natural systems and social system are eminent in those situations. In a sustainable port strategy, the integration of these different systems is fundamental. In the sustainable port strategy, the planning and management of port activities is done by looking at the activity's effect on all systems and in cooperation with the stakeholders belonging to these systems.

In today's increasingly complex world, the green port strategy is a strategy to accommodate the future development of the port in harmony with the region and the natural system.

Important aspects of such a strategy are:

- Efficiency and sustainability as complementary drivers
- Pro-active approaches like:
 - Working with Nature
 - Corporate Social Responsibility
 - Stakeholder participation
 - Responsible innovation
- Attract frontrunners, which attracts other frontrunners and better prepares the port for any future.

Sustainable thinking includes long term thinking. Sustainability pays. This gives the best guarantee for the license to operate and to grow and makes environmental permitting procedures the follow-up paperwork that consolidates the agreed practices. Port authorities and their (private) tenants then plan and manage their operations and future expansions (growth) together to manage the limited or decreasing environmental space and increased interactions between port and cities/nature. By accommodating this planning in harmony with the surrounding cities and nature, green growth can clearly be an economic driver.

A clear long-term vision and port strategy is vital and the basis for the plans and activities. And a sustainable port vision is not a separate thing. Sustainability should be one of the pre-requisites for a future-proof port.

For example, leading the plans and activities of the Port of Rotterdam is the following vision on the port and industry in 2030 (Port of Rotterdam Authority, 2011):

"In 2030, Rotterdam is Europe's most important port and industrial complex. It is a strong combination of the global hub and Europe's industrial cluster, both leaders in efficiency and sustainability. Rotterdam is closely linked to other North West European industrial and

logistic areas. Leading businesses make long-term investments in the most modern facilities. Close cooperation between businesses, government and knowledge institutions results in a high-quality labour market, living environment and accessibility. Our adaptive powers are unique. This makes the complex an important cornerstone for the welfare of the region, the Netherlands and Europe in 2030”.

And regarding sustainability and innovation objectives, the vision includes a.o. the following:

“Climate change makes it imperative to reduce greenhouse gas emissions. The port and industrial complex is of strategic value for Northwest Europe, but a nuisance to residents in the Rijnmond region. The responsible use of natural resources and the environment is a pre-requisite for a future-proof port. Without innovation, the port cannot meet the huge challenge of transition it faces. Knowledge and innovation are going to be of vital importance. The administrative overload and the bureaucracy associated with (spatial) development do not exactly contribute to the renewal and acceleration required. Therefore the vision for the port and industry must be, above all, ambitious”.

It is very important that such a vision is shared with and supported by the stakeholders that have a direct role in its accomplishment, such as governmental, provincial and municipal authorities and port industry. The Rotterdam Port Vision 2030 is therefore the result of an interactive and approval process with the body's that are relevant for the port governance.

Regarding the stakeholder engagement is important to focus on internal and external stakeholders. There are different ways to map and to engage stakeholders. Port of Rotterdam for instance uses the Mutual Gains Approach for the external stakeholders. This Mutual Gains Approach was developed by scholars and practitioners at the Consensus Building Institute, a Cambridge, Massachusetts based company founded by MIT professor Lawrence Susskind. The wording mutual gains is essential, because that is the success factor of the approach. But it also means that there must be mutual gains at hand. For a traditional port development project, it means that it needs to upscale to a broader scope to include stakeholder values related to the labour market, the living environment and accessibility. And as stated above, for a sustainable port those values determine the future strategies and create the conditions needed for the license to operate and grow. Therefore it is effective to bring them in from the start and make them part of the development, its constraints and opportunities. The role of the port could be to orchestrate the process. Bringing in the other stakeholders that have governance responsibilities and capabilities for the realisation of the shared values regarding labour market, living environment and accessibility also enables those stakeholders to scope their funding. The stakeholder's involvement therefore does not mean that the costs for the port will strongly increase. It is the development of port infrastructure in an integrated and future-proof way contributing to key people and planet values, for which also others are willing to pay.

A good example of this method and its results is found in the realisation and exploitation of the latest Port of Rotterdam expansion Maasvlakte 2, where from the start a dual objective was leading the project. This dual objective was that the expansion should contribute to the economic values as well as the liveability of the region that it serves. Under the umbrella

of the project Mainport Development Rotterdam, many assets were developed in a partnership between the country, the region, the city and the Port of Rotterdam. This included, next to the land reclamation Maasvlakte 2, nature compensation sites, recreational areas and river parks and measures to improve the liveability of the region. Fig. 4-11 gives an overview of all the project components.

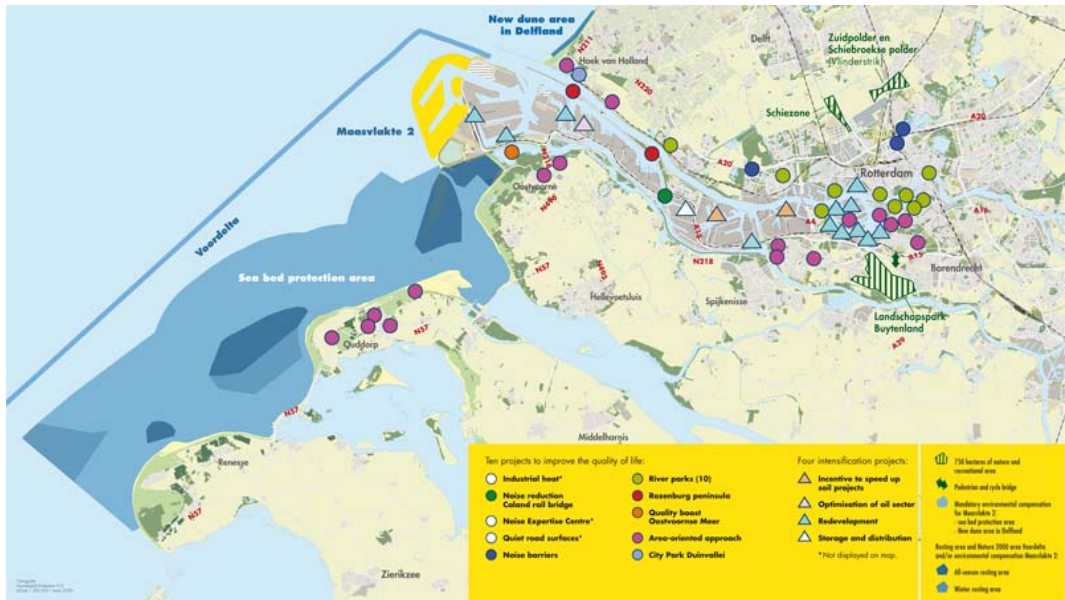

Fig. 4-11 Mainport Development Rotterdam

For a port authority, it is important to identify its own key corporate values with regard to revenues, image, sustainability, environment, connectivity, energy transition etc. and to assess how a port project can contribute to those values and how risks with regard to those corporate values in the development can be managed. It means that up-front it should be identified how port projects can add value to for instance biodiversity, environmental quality, renewable energy, landscape, living environment (incl. recreation) and regarding social challenges. And this again determines which stakeholders to involve to inclusively create those values.

Finally, the importance of the reporting on the sustainability should be recognised. It is needed to communicate transparently about the values, objectives and results obtained. An increasing number of ports nowadays is reporting, within the framework of a corporate social responsibility (CSR) policy, about indicators that cover economic, social and environmental issues. The cornerstone of CSR reporting however is the interaction with different stakeholders. Through identification of and reporting about relevant (environmental) issues, a basis is provided for new initiatives contributing to the license to operate, the basis for development and operations at each port. Some countries, like Spain, are promoting the obligation for ports to report regularly on their sustainable performance.

The Global Reporting Initiative (GRI) is a network-based organisation that produces a comprehensive sustainability reporting framework that is widely used around the world.

This reporting framework is based on the principles and performance indicators that organisations can use to measure and report their economic, environmental and social performance. Its cornerstone is the Sustainability Reporting Guidelines. The fourth version, the G4 Guidelines, is freely available. Next to these general guidelines on sustainability reporting, a few sectoral guidelines are also available (e.g., for airports). There are no sectoral guidelines yet for ports. An international working group, however, in collaboration with IAPH and PIANC, is preparing guidance for ports on sustainability reporting, which will include an annex with sectoral guidelines for ports. The publication is expected to become available fall 2017 (PIANC, to be published).

One of the lessons learned is that the guidance for sustainability reporting for ports should aim at a tailor-made approach, keeping in mind the possibilities of an individual port as well as the stakeholder interaction. It can help to create more transparency regarding sustainable performance. It is important that it includes a process in which the port authority and its stakeholders participate and jointly draft the key performance indicators that are relevant in their specific situation with regard to sustainability.

4.7 Adaptive Port Planning (Planning under Uncertainty)

4.7.1 Why Adaptive Port Planning?

Ports are beset with many uncertainties about their futures. They are confronted with new demands in terms of functions and scales, new external constraints, and changed expectations, and yet must ensure functionality, capacity and service quality during their design life time. The inability to do so can mean costly adaptations for a port, or loss of cargo and competitive position. Thus, planning ideally needs to anticipate on unexpected future developments and to ascertain that the infrastructure, once built, continues to function well. The Technical Masterplanning as described in Section 4.5 and depicted in Fig. 4.3 does not take any uncertainties into account beyond those included in the scenarios that form the basis of the forecasts. The lay-outs are prepared for the middle scenario and when the actual development deviates from this scenario, the port is often able to accommodate this by postponing or accelerating a next phase. However, this does not work in case of disruptive developments. An example is the drastic reduction in coal imports due to closure of coal-fired power plants.

A new planning approach is required that aims at developing plans that take uncertainties more explicitly into account, and allow for change, learning, and adaptation over time based on new knowledge and changing circumstances. Such flexible or adaptable plans allow the port to be altered or employed differently, so as to be functional under new, different, or changing requirements in a cost-effective manner. Adaptive Port Planning (APP) aims to achieve this by bridging the gaps in the traditional practices of port planning by incorporating uncertainty and flexibility considerations.

It provides a framework for the planner to generate plausible alternatives in the context of the planning objectives; identify critical uncertainties (vulnerabilities and opportunities); and then, to explore, value, and incorporate flexibilities for handling these uncertainties.

Subsequently, actions can be taken in the planning stage, or actions can be prepared in advance and taken as events occur. Next, the planner evaluates the alternatives and makes a selection (the value of flexibility is included in the evaluation). During the implementation phase, actions are taken in response to triggers from a monitoring system set up for the selected alternative. Such a monitoring system scans the external environment for new developments and alerts planners of the need to modify or reassess the plan.

4.7.2 Steps in Adaptive Port Planning

The various steps as illustrated in Fig. 4.12 are explained below.

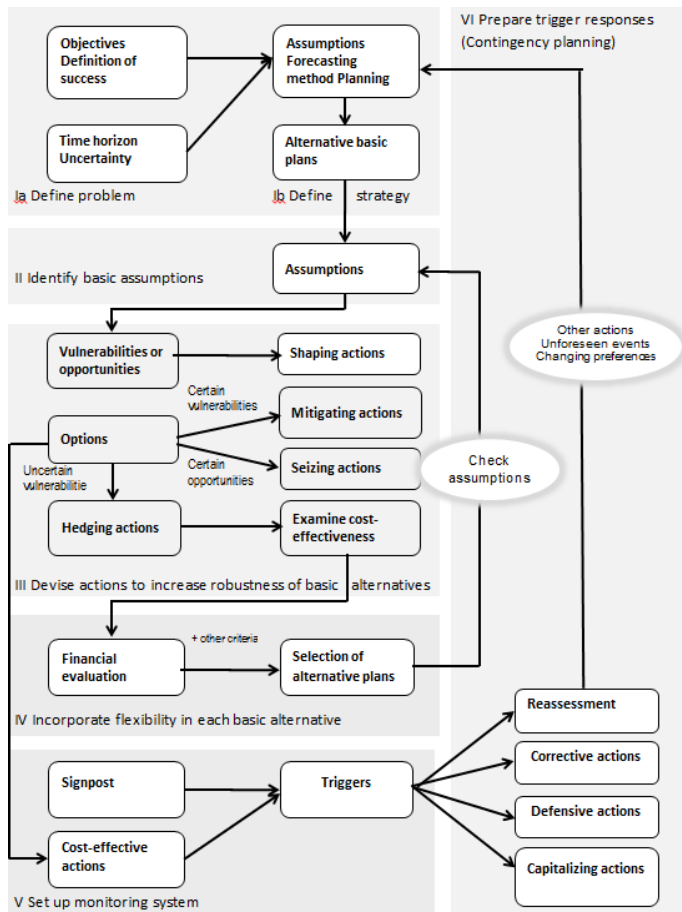

Figure 4.12 Steps in APP

Step Ia Define the problem/project

This first step involves studying the objectives of the organization and the needs of the stakeholders in order to formulate the goals of the project. Based on this, a definition of success can be given, in terms of the specification of desired outcomes. The various constraints or boundary conditions, the available choices, and the underlying assumptions are

identified next. An assumption is an assertion about some characteristic condition that underlies the current plan.

Step Ib Define strategy and formulate alternatives

The strategy includes selecting a forecasting method, planning techniques and tools, as well as a (financial) evaluation method. The planning time horizon (short, middle or long) determines the choice of strategy. In case of port projects these can relate to the various port layouts, infrastructure designs or the complete Master Plan.

Step II Identify vulnerable assumptions underlying each alternative plan

Identifying vulnerable assumptions in the plan requires an assessment of the consequences of failure of an assumption. It involves thinking about the future, for plausible developments that could occur in the lifetime of a plan and cause the plan to fail. If the development is favourable for the plan, it is called an opportunity. Otherwise, the development is called a vulnerability.

Step III Increasing the flexibility and robustness of each alternative

In the third step of the process, the robustness of each alternative is increased. This step is based on specifying actions to be taken in response to the vulnerabilities and opportunities identified in Step II. There are two basic ways of preparing a plan for vulnerabilities and opportunities, either by taking actions now (in the planning and design phase), or by preparing actions in advance that can be taken in the future, if necessary. See Taneja (2013) for definition of action types in Steps III and VI.

Step IV Evaluate and select alternative

After actions to make the plan robust have been identified and incorporated in each alternative, we must compare the alternatives. This comparison of alternatives requires determining the effects of the alternative based on pre-defined criteria. Financial, economic or cost-benefit analysis are commonly carried out.

Step V Set up monitoring system for the selected alternative

Even with actions taken in advance, there is still the need to monitor the performance of the selected alternative and take action if some of the assumptions are failing. This requires an identification of signposts. Signposts specify information that should be tracked in order to determine whether the plan is on course to achieving its success.

Step VI Contingency planning (preparing trigger responses) for the selected alternative

In this step, the plan, based on the selected alternative, is further enhanced by including adaptive elements. A contingency plan is a provision in the plan that specifies how a vulnerability will be handled, in case events or changes cause the vulnerability to appear. These actions are prepared for in advance.

Once the basic plan and additional actions are agreed upon, the final step involves implementing the entire plan.

4.7.3 Comparison of the planning approaches

Table 4.2 compares the key features of the traditional and adaptive planning approaches.

Table 4.2 Comparison of Traditional and Adaptive planning approach

	Traditional approach to Master Planning	Adaptive planning approach
Treatment of the future	Assumes it is useful and possible to forecast the future	Assumes that the future cannot be forecasted, or it is dangerous to do so
Treatment of uncertainties	Uncertainty is included in the forecast, and the masterplan allows for some flexibility in the planning	Imagines <i>trend-breaks</i> and prepares for them
Planning process	Static or at most periodic	Dynamic and continuous
Focus	On demand forecasts	On vulnerabilities and opportunities
Approach	Target oriented	Performance oriented (thus, flexible and integrated)
Reactivity	Ad hoc reaction to strong signals (certain knowledge about the future)	Monitors and reacts to predefined triggers (mostly performance indicators)
Decision-making	Decisions are based on available information	Regular acquisition of new information and evaluating potential developments as a way to deal with uncertainty

Chapter 9 of Taneja (2013) presents case studies addressing varied planning needs in the port sector, which demonstrate that incorporation of uncertainty and flexibility consideration leads to very different plans. The addition of adaptive actions to the plans limits future surprises. And finally, it recommends that alternatives that are robust for a range of plausible futures are to be preferred above those that are optimal for a single future. One of these case studies has been included in this book as Appendix A.

4.8 Concluding remarks

The previous sections present the “ideal” masterplanning process, but one should be aware of conditions that may hamper the preparation of a masterplan along these lines. Some of these conditions are:

- (i) Strategic planning: many of the world's ports have to operate more or less on a commercial basis and are supposed to show a profit at the end of the year, but they

also have to maintain their position in a competitive environment, e.g. the ports in the Hamburg-le Havre range.

For these ports traditional master planning and strategic planning go hand in hand with only one outcome.

In anticipating on what the competition is doing, or may do, ports can decide on investments which are not or not yet required for strict economic considerations, but may be necessary to secure the position of the port in the future, which is the defensive side of strategic planning.

Ambitious ports may also formulate perspectives for their future role in regional transport that go well beyond regular and predictable growth patterns. For these ambitions to materialize, first of all they have to be translated in the masterplanning process.

(ii) Frequent obstacles in port planning are :

- Unsatisfactory basic data: outdated, insufficient or unreliable
- Too much rigidity in the extrapolation of historical developments
- Shortcomings in the systems approach and the planning methodology
- Lack of insight and experience of local port authorities; insufficient understanding of the time and costs involved in in-depth studies
- No adjustment to regional or national port developments
- Too much attention to infrastructural provisions and an underestimation of the importance of operational and organisational aspects
- Relatively too much accent on the port activities on the sea-side and too little on the land-side (more parts are 'ailing' on the land-side than on the sea-side, either in the port itself or in its hinterland connections)
- Unfamiliarity with or underestimation of the demands that the reception of big, difficult-to-manoeuvre ships make on the infrastructure of the port, i.e. underestimation of the nautical requirements
- Unfamiliarity with safety aspects associated with the handling of dangerous cargoes

Throughout the world, big mistakes have been and are still being made for many of the above reasons. In the past 10 to 15 years alone, hundreds of millions of dollars have been invested in new ports that, after completion, turned out to be either partly or completely non-functional.

(iii) Specific problems in many countries in the developing world are:

- Management
 - The port management is often inefficient, too much of the decision-making process rests with the central government and too little with local administrators.
- Operations
 - Cargo handling and goods storage are frequently left in the hands of the port authority and this usually results in low productivity
 - Long transit times of goods in the ports
 - Inefficient organisation of storage facilities, leading to the necessity of over

dimensioning of storage yards

- Customs
- Often an obstacle in the administrative goods handling. This contributes to the long periods that the goods remain in the port.
- Port congestion
More often caused by organisational and operational shortcomings than by deficiencies in the infrastructure. It should also be borne in mind that organisational improvements are considerably cheaper than extensions of the infrastructure.
- Poor maintenance and lack of spares
Necessitates port structures and equipment that require a minimum of maintenance and, occasionally, the purchase of an excess of cargo handling equipment.
- Specialisation in goods handling
Often trying to catch up with developments in the West and according to imaginary needs. Specialisation should not be a forced process as drastic changes demand adaptations over a long period. Equipment should not be unnecessarily sophisticated and comply with local operational and maintenance skills.

This implies that a lot of improvement can be achieved in existing ports, before starting to build new facilities. This should be taken into account in the pre-feasibility stage: how can the operations be improved, in terms of better management, simplified procedures, introduction of regular maintenance programmes etc.

4.9 References

- Belli, P., J.R. Anderson, H.N. Barnum, J.A. Dixon, J.P. Tan, Handbook on economic analysis of investment operations, Operational Core Services Network Learning and Leadership Center, 1998
- Belli, P., J.R. Anderson, H.N. Barnum, J.A. Dixon, J.-P. Tan, Economic analysis of investment operations: Analytical tools and practical applications, World Bank Institute, 2001
- British Treasury, Cost benefit guidance for local partnerships, London, 2014
- Department for Communities and Local Government, Multi-criteria analysis: a manual, London, 2009.
- ESPO, Green Guide Annex 2, Legislation influencing European ports, Brussels, 2012.
- Goda, Y., Random seas and design of maritime structures, Un. of Tokyo Press, 1985
- Hogben, N. et al, Ocean Wave Statistics, Hydrographic Dept., London, 1967
- PIANC, Seismic Design Guidelines for Port Structures. Balkema, 2001
- PIANC, Masterplans for the development of existing ports, Brussels, 2014
- PIANC, Sustainable Ports – A Guide for Port Authorities, Brussels, 2014
- Pilot (various geographical regions), Hydrographic Dept., London
- Port of Rotterdam Authority, Port Compass - Port Vision 2030, Rotterdam, 2011
- Romijn, G. and Renes, G., General guide for Social Cost Benefit Analysis, CPB/PBL, The Hague, 2013 (in Dutch).
- Schwartz, P., The art of the long view, planning for the future in an uncertain world, Doubleday, a division of Bantam Doubleday Dell Publishing Group, Inc., New York, 1991.

4 Port planning methodology

Taneja, P. et al, Adaptive Port Planning using real options. Proc. IAME Annual Conf., Lisbon 2009.

Taneja, P., The Flexible Port, PhD Thesis, Next Generation Infrastructure Foundation, 2013
UNCTAD, Port Development, Handbook for planners in developing countries, April 1985

U.S. Army Corps of Engineers, Coastal Engineering Manual, EM 1110-2-1100, Washington D.C., 2002

U.S. EPA, Guideline for preparing Economic Analyses. National Center for Environmental Economics, 2010

Vellinga, T., Environmental issues in port development and port operation, Delft Academic Press, 2004

Chapter 5

Planning and Design of the Water Areas

5.1 Introduction

As explained in the previous chapter the lay-out of a port is to a large extent determined by its wet surface. This includes the orientation and dimensions of the approach channel, the manoeuvring areas within breakwaters (if these are needed), turning circle, and port basins for the actual berths. These components are of great importance, Firstly because they constitute a major part of the overall investment, secondly because they are difficult to modify once the port has been built.

The design aspects are mostly centred on the ship: its manoeuvring behaviour under influence of wind, currents and waves, its vertical motions in waves, the horizontal and vertical motions at berth. We therefore have to understand somewhat more about the manoeuvring behaviour and hydrodynamic responses of the ship. Another aspect to be taken into account is sediment transport. What is the effect of the port lay-out on the natural process, and hence on the coast. And how can siltation inside the port and approach channel be minimised by the lay-out.

Finally environmental and safety aspects may play a role in the lay-out. A major issue in the expansion or deepening of existing ports and channels is the removal and depositing of dredged material. Often this is polluted to some degree and if so (international) regulations prevent that this can be dumped at sea (London Convention, 1995 and PIANC, 1997). In many countries environmental regulations require mitigation and compensation measures to be taken, when port (or other) development affects existing ecological systems. In the design of new land for terminals within the Port of Los Angeles an area had to be allocated for an underwater habitat to replace an existing area. And in the realization of Maasvlakte 2 in Rotterdam ample surface area had to be created for nature development and recreation. Safety considerations lead in some cases to additional requirements, such as the LNG import jetty in Zeebrugge, which has its own basin, well isolated from other port areas (see Figure 5.1).



Figure 5.1 The harbour of Zeebrugge

5.2 Ship Manoeuvring and Hydrodynamic Behaviour

5.2.1 Basic Manoeuvrability

Ships sail from one “waypoint” to the next. The direction to the next waypoint is called the course. In the approach to and inside ports ships often need to change course when reaching the next waypoint. This is the manoeuvring.

Considering the factors that influence a ship’s manoeuvring behaviour, the basic properties belonging to the vessel itself are called here vessel manoeuvring characteristics. They are determined by the ship’s hull shape, its mass, the rudder system and dimensions, the propulsion system and the power. The manoeuvring characteristics are:

- i. The way the ship reacts to the rudder and to changes in propeller revolutions
- ii. Turning ability
- iii. Stopping ability

i Rudder efficiency

Giving rudder angle creates a moment on the ship, when sailing. The effect of the propeller flow on the rudder increases this moment. Big tankers and bulk carriers commonly have a relatively small L_s / B_s (length / beam) ratio, in the range of 6 to 7, and a large block coefficient, in the range of 0.75 to 0.85. Together with the B_s / D (beam/draft) ratio, the Δ/P ratio (mass/propulsive power) and the rudder area, these factors mainly determine the manoeuvring characteristics. A small B_s / D ratio and a large block coefficient result in a relatively long time to react to an applied rudder angle; but, once the ship is rotating, it has a good turning ability.

It is clear that these characteristics are important for the manoeuvring ability of the vessel in a channel. However, equally essential is the way the human operator on the bridge uses the manoeuvring characteristics in steering the vessel.

In confined water, the reaction time of the ship to an applied rudder angle can be reduced by a simultaneous rudder and propeller action, the latter only during a short time (a ‘burst’) to avoid a noticeable increase in ship speed. The effect of this manoeuvre increases at decreasing speed.

In general, course stability indicates the extent to which the ship reacts on external disturbances. A ship is called to be course stable when the moment exerted by the rudder, counteracts the movement of the ship caused by the initial disturbance. After moment and forces become zero again, the ship follows its course. This does not occur with a course unstable ship. The moment then strengthens the initial rotation. The ship continues turning, even after forces and moment reach a new state of equilibrium. In shallow water, the course stability tends to be better than in deep water.

The direction of the ship’s bow may differ from the course. A ship sailing under the influence of a cross-current or cross-wind will have a certain drift angle between her heading and course. The drift angle makes the “swept” path wider than the beam of the ship. But even without external disturbances the ship’s real course shows a sinusoidal movement instead of the intended straight course. This is due to the speed of res-

ponse of the helmsman and that of the ship in reacting to the rudder. The total width of the basic manoeuvring lane exceeds therefore the beam width of the vessel (see Figure 5.2). The extent of this depends again on the ship's manoeuvrability, the ability of the helmsman, the visual information available and the overall visibility. This point comes back in Section 5.3.2.

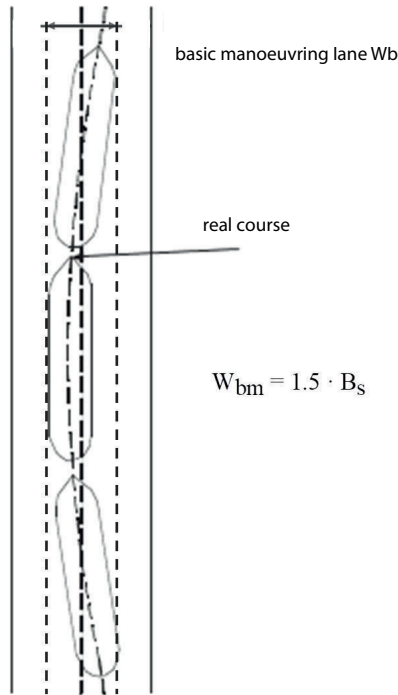

Figure 5.2 Lane width of ship

ii Turning manoeuvre

The turning radius depends on the vessel type and length, the rudder angle and – efficiency and the water depth over draught ratio. In general one can say that the radius becomes smaller in more shallow water. For $h/d = 1.2$, typical for dredged approach channels, and a rudder angle of 20° , which is a good measure for taking a bend, the turning radius may vary between 1400m for a 350m long LNG carrier (known to have good manoeuvrability) and 2800m for an Ultra Large Container Carrier (ULCC). General Cargo and bulk vessels have intermediate values for the turning radius. The radius for smaller ships drops linearly with the length. But these are rarely determining for design.

Turning capability at low speeds is often better for vessels with twin propeller arrangement and can be further improved by applying the bow thrusters, when available,. Bow thrusters are useful for berthing and unberthing operations, but at speeds of 3 kn and above, they lose much of their effect.

iii Stopping distance

The stopping distance is affected by:

- The size of the vessel and the relation propulsive power - displacement (= mass)
- The speed at which the vessel enters the port
- The stopping procedure

As concerns size, the ratio propulsive power over mass of the vessel is inversely proportional to ship size. In consequence, the power available for decelerating (or accelerating) decreases in a relative sense with increasing ship size (see Figure 5.3). Also the astern power as a fraction of the installed power varies from one system to another, and may be as low as 50% for a vessel with steam turbine and fixed-blade propeller to close to 100% for a vessel with diesel engine and controllable pitch propeller.

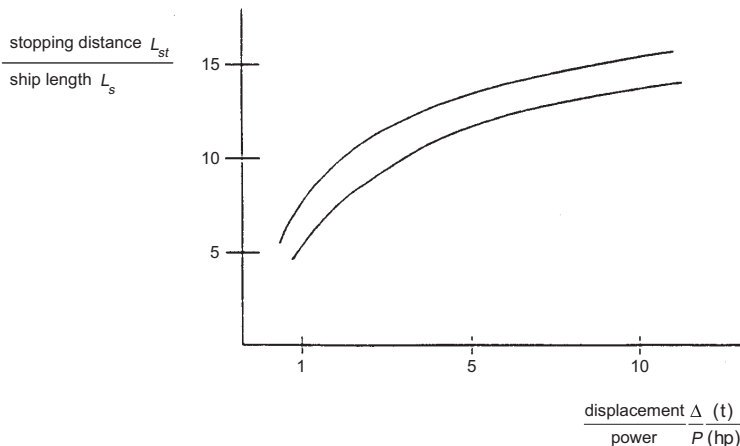

Figure 5.3 Stopping distance of ships sailing at cruising speed

This means that the distance L_{st} , required for stopping from a given speed, expressed as a function of the ship's own length L_s , varies considerably and increases with increasing ship size. For example, a 10,000 t general cargo vessel is able to stop from a cruising speed of 16 kn in a minimum distance of about 5 to 7 L_s , say 900 m (*crash stop*), whilst a 200,000 t bulk carrier or tanker requires some 14 to 18 L_s , say 4800 m. Starting from a low speed, say 5 kn, the stopping distances are obviously smaller; for a big tanker $\leq 3 L_s$, for a general cargo ship $\leq L_s$.

With regard to the *port entry speed*, it will be obvious that the higher the speed, the bigger the stopping distance required. The minimum speed at which a vessel still has sufficient rudder control to make course corrections, is about 4 kn. However, waves, wind and, particularly, cross-currents in front of the port entrance may force a ship to maintain a higher speed until it has arrived within the shelter of the breakwaters. This will be further discussed in Section 5.4.

A degree of *course control* can be maintained by giving periodically brief ahead propeller thrusts with the rudder set to give the desired course corrections. This, however, unavoidably leads to greater stopping distances.

Finally, as concerns the way of stopping, different procedures are possible. The two extremes are the crash stop on the one hand, and the fully controlled stop on the other. In the crash stop, the engines are set at full astern. It gives a minimum stopping distance, but, due to turbulent flow around the rudder, the vessel has no course control whatsoever. It turns either to starboard or to portside as shown in Figure 5.4.

number	A2	A3	A4	A5	A6	A7	A8	A9	J1	J2	J3
rudder deg	0	0	0	0	0	0	0	0	30	30	30
speed ht	9	4.9	14.8	4.2	15	2.4	13	5	16.2	11	14.4
revs	42	44.7	42.5	48.8	47.5	46.7	38.3	48.3	42.9	47.7	47.5
h/T	∞	∞	2.1	2.2	1.7	1.5	1.3	1.4	∞	∞	1.7

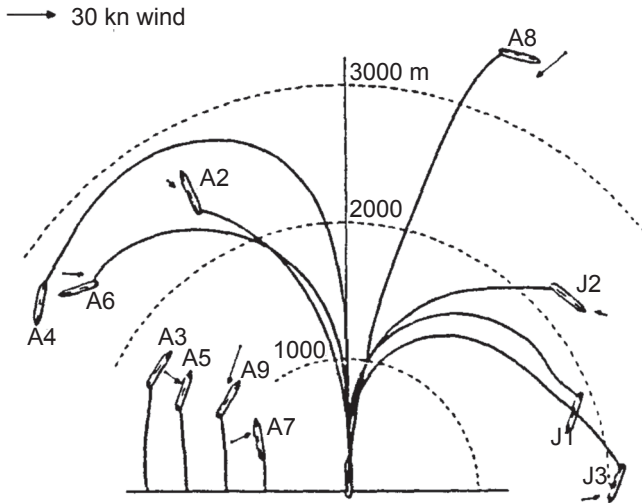

Figure 5.4 Stopping manoeuvres tanker MAGDALA, 220,000 t [Source IAHP 1981]

5.2.2 Ship Hydrodynamics

A basic understanding of the forces exerted by waves, currents and wind and the responses of the ship is necessary in port planning and design for the following reasons. Firstly the vertical motions of a ship in waves have to be taken into account in the design depth of approach channel, turning circle and other manoeuvring areas, and at the berth. Secondly the design of the mooring system at the berth of an exposed jetty aims at restraining the vessel in its natural movements and therefore the ship motions and forces in mooring lines and fenders have to be determined.

i *Sailing ships*

A free floating vessel has six modes of freedom of motion: three lateral and three rotary. In consequence, a ship exposed to waves may respond in six different modes, or in any combination thereof (Figure 5.5).

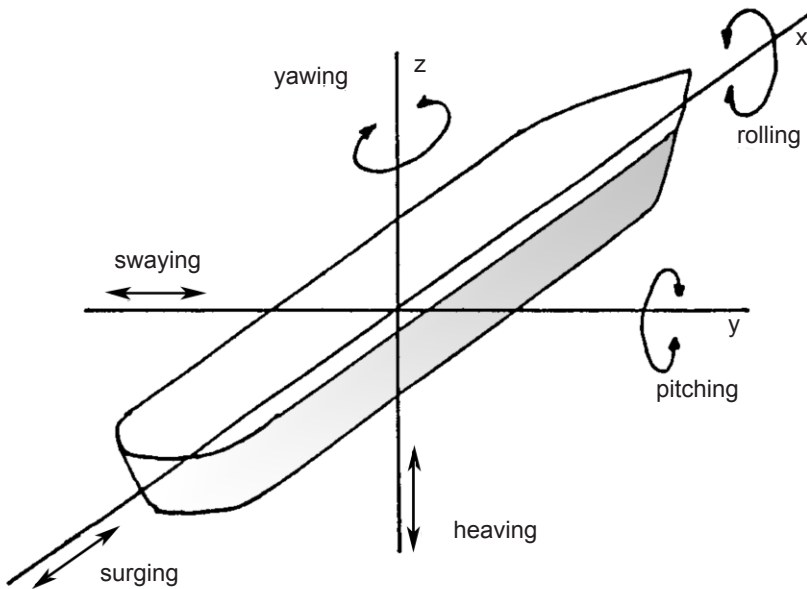

Figure 5.5 Ship motions

In the vertical modes, a ship has its own natural frequency of oscillation. If *excitation* occurs in a particular mode in a frequency near the ship's natural frequency in that mode, *resonance* will result. Whether this resonance is important, depends on the degree of damping. Of the three modes -rolling, pitching and heaving-, the latter two are rather damped motions, but not so the roll motion which is quite resonance-sensitive. A ship sailing in a strong beam sea with a wave period near the ship's natural roll period, may develop very large roll angles in which it loses rudder control and may even capsize.

In deep water, the *natural roll period* is usually between 10 s and 17 s for larger merchant-type ships. In wind-generated waves with (common) wave periods between 6 s and 10 s, roll motions need not be of great concern. However, the apparent *incident wave period* T_a will increase when the waves approach from astern (and decrease when the ship is sailing against the waves) and the ship has forward speed, and hence roll motion may become critical for wave directions between 120° and 150° with the ships course.

In order to determine the vertical oscillating motions of an arbitrary point at the ship's hull, the cumulative effects of heave, pitch and roll have to be considered. The system can be described mathematically as a mass-spring system with 6 *degrees of freedom*. On the free floating vessel the hydrostatic forces act as springs: if a ship dives with its

nose into the water the excess buoyancy drives it back. In case of a moored vessel additional springs are found in the mooring lines and fenders.

The analysis of ship motions was for a long period of time done in model tests. Only after about 1990 numerical models became more reliable. Whereas for ships sailing in deep water computations on the basis of strip theory or 2D-diffraction models may give satisfactory results, for ships in shallow water more advanced models are required, such as 3D-BEM type models.

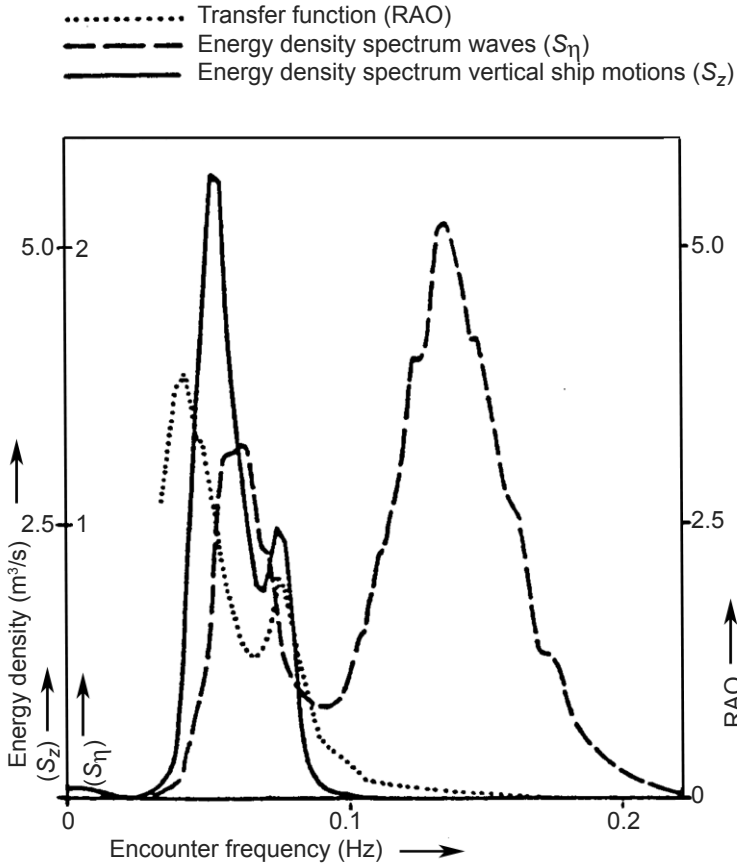

Figure 5.6 Characteristic ship motions in waves

Assuming linearity, the response of the ship is calculated for a number of distinct wave periods (or frequencies). The ratio of motion amplitude and wave amplitude for a particular frequency is the *Response-Amplitude factor*. Over the entire range of wave frequencies (the wave spectrum) the Response-Amplitude factors constitute a transfer function, the *Response-Amplitude Operator (RAO)*. When we have the RAO function for a specific ship for different wave directions, we can calculate all motions individually for a given *wave spectrum*. Figure 5.6 is an example of the RAO function for the effect of roll, heave and pitch combined. By multiplying the values of the wave spectrum with $(RAO)^2$ the motion spectrum is obtained. Although the wave spectrum has a peak at about 0.14 Hz or $T = 7$ s, there is virtually no ship response because that

frequency is far higher than the natural frequency of the ship motions. The low frequency peak of the wave spectrum, at 0.06 Hz or 16-17 s does give resonance, even though the RAO is not at its highest value. It is clear that the amplitude of the resulting ship motion would increase rapidly for wave periods above 17 s.

Finally, attention is drawn to the abscissa of Figure 5.6 giving the encounter frequency. This is the apparent wave period T_a for the ship sailing at speed V_s . The relation with the actual wave period T is obtained via the *wave celerity* as follows:

$$L = c \cdot T = c_a \cdot T_a = (c \pm V_s) \cdot T_a$$

$$T_a = \frac{c}{c \pm V_s} \cdot T \quad (5.1)$$

For stern waves V_s is subtracted in Equation 5.1 ($T_a > T$) and for head waves V_s is added. When waves come in under an angle with the ship's course the component of V_s has to be used in Equation 5.1.

From the above introduction it may be concluded that the wave forces on and the response of a sailing ship in waves can not be easily determined by analytical formulae. A first assessment of possible resonance can be obtained from the following reasoning:

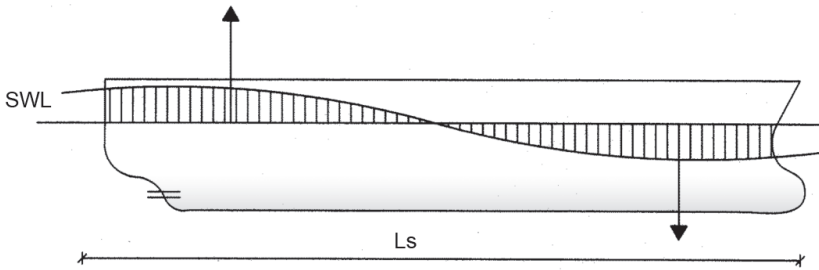

Figure 5.7 Characteristic ship motions in waves: Pitching

a. Pitching

When the ship sails in or against the direction of the waves, the pitch moment exerted by the waves is maximum for wavelength $L = 2 \cdot L_s$. The corresponding wave period gives the highest response factor. For a vessel length of 250 m, this means $L = 500$ m and (assuming relatively shallow water) a wave period $T = 30$ s. Such long waves are rare and if they occur have very small amplitude. For wave directions α close to 90° (beam waves) the critical wave length becomes $L = 2L_s \cos \alpha$, and hence much shorter wave periods lead to pitching resonance (always in combination with roll, leading to a corkscrew motion of the ship).

b. Rolling

The *Eigen period* or natural period of a ship for roll depends on its size, meta-centric height and mass distribution. Typical roll periods amount to 12-16 seconds for a 250,000 t tanker to 7-8 seconds for a 10,000 t cargo ship. For beam waves with periods close to the natural period resonance will occur. This is why ships, in case of higher waves, try to avoid a course between 45 and 90° with the wave direction and why an approach channel with an angle > 45° to the dominant wave direction should be avoided.

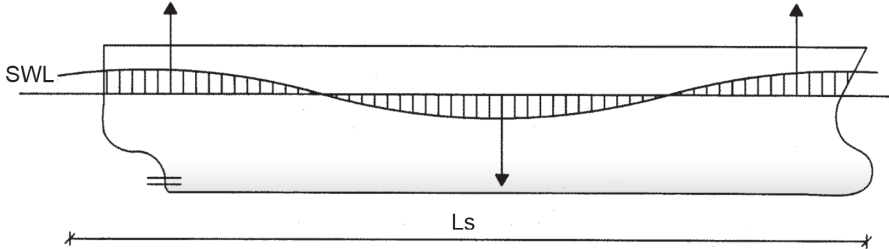

Figure 5.8 Characteristic ship motions in waves: Heaving

c. Heaving

For $L = L_s$ the resultant vertical force of the ship is zero, as shown in Figure 5.8. For the corresponding wave period the heave response is zero. With increasing wave period, and thus wave length, the incident force and the heave response will increase. With decreasing wave period there may initially be a slight increase of response, but then it reduces to zero.

Squat is caused by the flow of water past and under the moving ship. The velocity field produces a change of the hydrodynamic pressure field around the hull, in particular at the ship keel, which can be compared with the Bernoulli effect in Open Channel Flow. Squat is proportional to V_s^2 , V_s being the ship speed relative to the water. The pressure drop leads to sinkage of the entire vessel. But depending on the circumstances the pressure drop can be larger at the bow or at the stern, leading to so-called dynamic trim. On which side of the ship this happens is determined by the mean draught, a possible static trim, but also the particular shape of bow and/or stern. For our purpose this does not matter as only the maximum squat determines the required channel depth (see Section 5.3.3).

The squat increases with decreasing water depth as the return flow under the ship increases. Hence squat becomes an important factor in the design of the depth of approach channels.

ii Moored ships

The assumption of linearity mentioned above holds reasonably well for sailing ships in first-order waves (i.e. the observed waves). In the case of a moored ship it becomes less accurate because the reaction forces of mooring lines and fenders are generally not linear. Moreover the moored ship, in particular a large one, becomes sensitive to so-called *second-order* or *sub harmonic wave forces*, due to the high resonance periods for surge and yaw of the system. These wave forces include the wave drift force inherent to any random wave field, or additionally may be caused by very long, low amplitude waves as occurring in swell propagating over large stretches of ocean or as edge waves along the continental shelf. The distinction between the *bound* and the *free* long waves

is difficult to make. An indication is given by the analysis of long period wave recordings for the port of Sines (Vis et al, 1985). In these cases the ship motion analysis has to be made by means of the non-linear computer models, including all 6 degrees of freedom and the effects of second-order wave forces.

For a first estimate of wave, current and wind forces on a moored ship use is made of empirical formulae based on model tests and simplified computer computations.

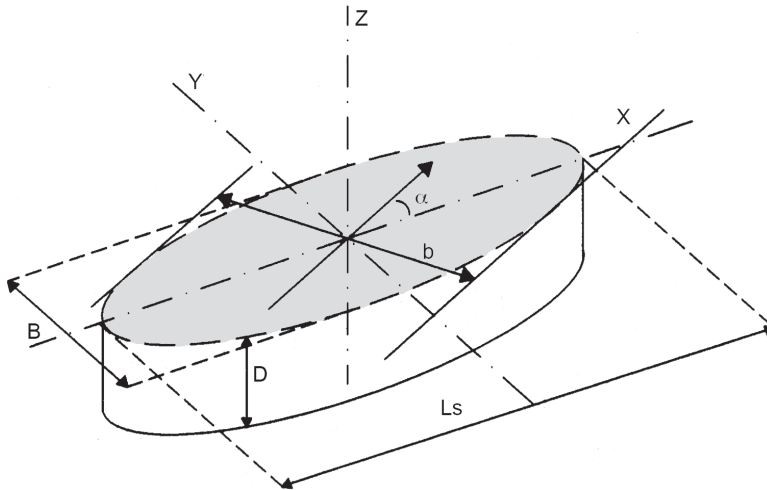

Figure 5.9 Wave force in longitudinal (X) and lateral (Y) direction

a Wave forces

The wave force in longitudinal (X) and lateral (Y) direction is derived from computer computations of the force on a vertical elliptical cylinder with dimensions L_s , B_s and D , held fast (i.e. not allowed to move in its mooring lines). It is stressed that this is a strong schematisation of reality, as even the most tight mooring system does allow some movement, especially with the aim to reduce the line forces. Consequently the forces are much higher than in reality.

The direction of the *incident* waves, with wave length L and height H , is α . The expressions for the wave forces read:

5 Planning and Design of the Water Areas

$$F_{x,\max} = C_{mx} \frac{\sinh(2\pi \frac{h_{berth}}{L}) - \sinh(2\pi \frac{h_{berth}-D}{L})}{\cosh(2\pi \frac{h_{berth}}{L})} \frac{\pi \cos \alpha}{8} W_{shelter}^2 wH \quad (5.2)$$

$$F_{y,\max} = C_{my} \frac{\sinh(2\pi \frac{h_{berth}}{L}) - \sinh(2\pi \frac{h_{berth}-D}{L})}{\cosh(2\pi \frac{h_{berth}}{L})} \frac{\pi \sin \alpha}{8} W_{shelter}^2 wH \quad (5.3)$$

with additionally:

C_{mx}, C_{my}	= virtual mass coefficients	[-]
h_{berth}	= water depth at the berth location	[m]
$W_{shelter}$	= sheltering width in the wave direction	[m]
	= $B_s + (L_s - B_s) \cdot \sin \alpha$	
w	= specific weight of seawater (= 10.25 kN/m ³)	

The coefficients C_{mx} and C_{my} have been determined for various wave conditions and ship sizes and are presented in dimensionless graphs, such as Figure 5.10 (Goda, 1972)

b. Current forces

The current forces on a ship are proportional to the cross-sectional area underwater and the average current velocity squared. Like the force on a plate with area A in flowing water:

$$F = C \cdot A \cdot v^2$$

The value of C depends on the angle of current direction with the ship axis, on the underkeel clearance (the ratio of ship draught and water depth) and on the shape of the ship's bow: a conventional or a bulbous bow. Due to the asymmetry of the longitudinal section the working line of the lateral force may have a (small) offset from the point amidships, which is taken as the centre of the co-ordinate system (see Figure 5.11).

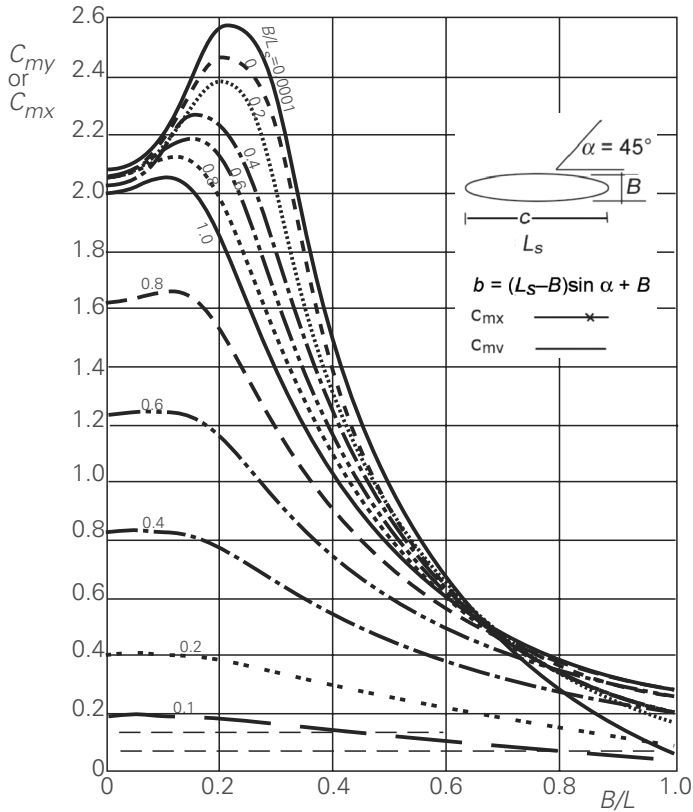

Figure 5.10 Virtual mass coefficients for $\alpha = 45^\circ$

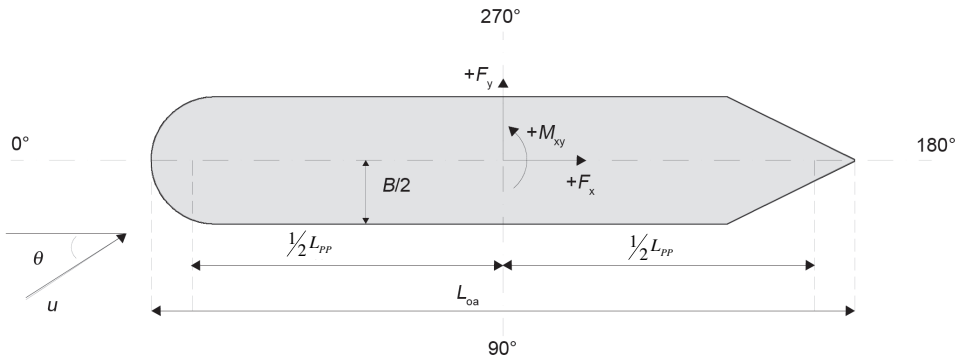

Figure 5.11 Sign convention and coordinate system

This can be shown as a moment M_{xy} in addition to the lateral force F_y . But another way is to determine the two lateral forces at the fore perpendicular and at the aft perpendicular. This is generally more convenient for hand calculation, because the mooring lines fore and aft have their resultant at those points along the ship length. In the latter case the formulae for F_x , F_{yF} and F_{yA} become:

$$F_{xc} = \frac{1}{2} C_{xc} \cdot \rho_w \cdot V_c^2 \cdot D \cdot L_{PP} \quad (5.4)$$

$$F_{yFc} = \frac{1}{2} C_{yFc} \cdot \rho_w \cdot V_c^2 \cdot D \cdot L_{PP} \quad (5.5)$$

$$F_{yAc} = \frac{1}{2} C_{yAc} \cdot \rho_w \cdot V_c^2 \cdot D \cdot L_{PP} \quad (5.6)$$

(It is noted that in all three equations $D \cdot L_{PP}$ is used, while one would expect $D \cdot B_s$ in the first one. This is done for ease of calculation). The forces are found in kN. The other parameters are:

- C_{xc} = longitudinal current force coefficient [-]
- C_{yFc} = transverse current force coefficient fore [-]
- C_{yAc} = transverse current force coefficient aft [-]
- ρ_w = density of sea water (= 1025) [kg/m³]
- V_c = average current velocity over the underwater part of the keel [m/s]
- D = ship draught (for condition considered) [m]

Values for the *current force coefficient* are obtained from graphs based on experimental (model) data. An example of such graphs for a water depth to draught ratio of 1.1 is given in Figure 5.12 and Figure 5.13. A complete set of graphs for different loading conditions and water depth to draught ratios is found in the OCIMF publication "Mooring Equipment Guidelines" (OCIMF, 2008).

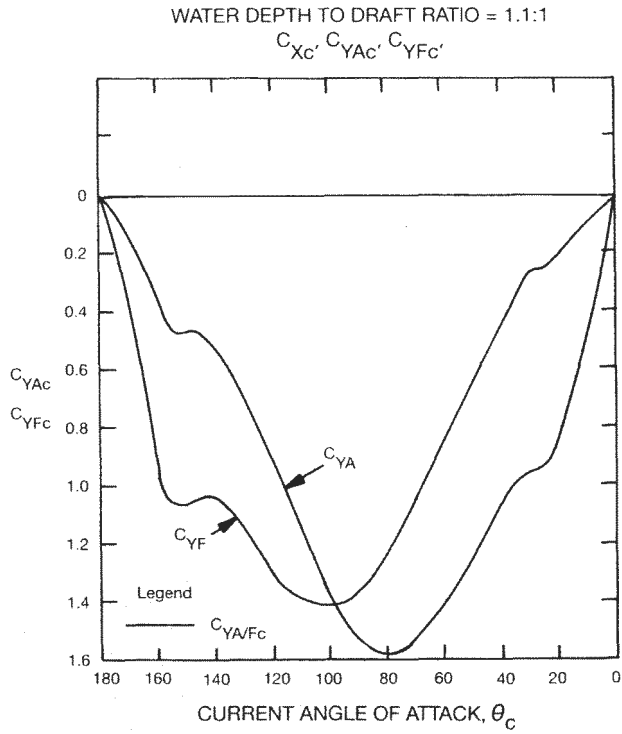

Figure 5.12 Lateral current force coefficient at the forward and aft perpendiculars loaded tanker

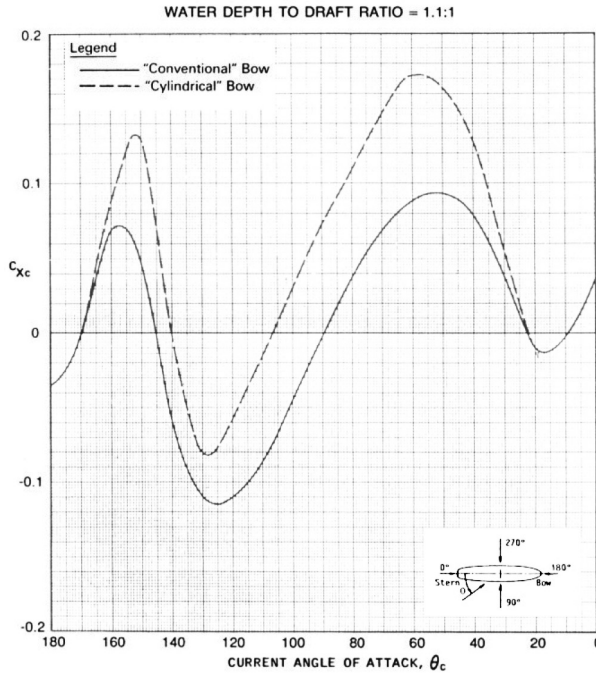

Figure 5.13 Longitudinal current force coefficient, loaded tanker

c. Wind forces

The wind forces are calculated in a similar way, applying the same sign convention as for current forces, using the following equations:

$$F_{xw} = \frac{1}{2} C_{xw} \cdot \rho_{air} \cdot V_w^2 \cdot A_T \quad (5.7)$$

$$F_{yFw} = \frac{1}{2} C_{yFw} \cdot \rho_{air} \cdot V_w^2 \cdot A_L \quad (5.8)$$

$$F_{yAw} = \frac{1}{2} C_{yAw} \cdot \rho_{air} \cdot V_w^2 \cdot A_L \quad (5.9)$$

- F_{xw} = longitudinal wind force [kN]
- F_{yFw} = lateral wind force fore [kN]
- F_{yAw} = lateral wind force aft [kN]
- C_{xw} = longitudinal wind force coefficient [-]
- C_{yFw} = lateral wind force coefficient fore [-]
- C_{yAw} = lateral wind force coefficient aft [-]
- ρ_{air} = density of air (1.0223) [kg/m³]
- V_w = wind velocity at 10 m elevation [m/s]
- A_T = transverse above water area [m²]
- A_L = longitudinal above water area [m²]

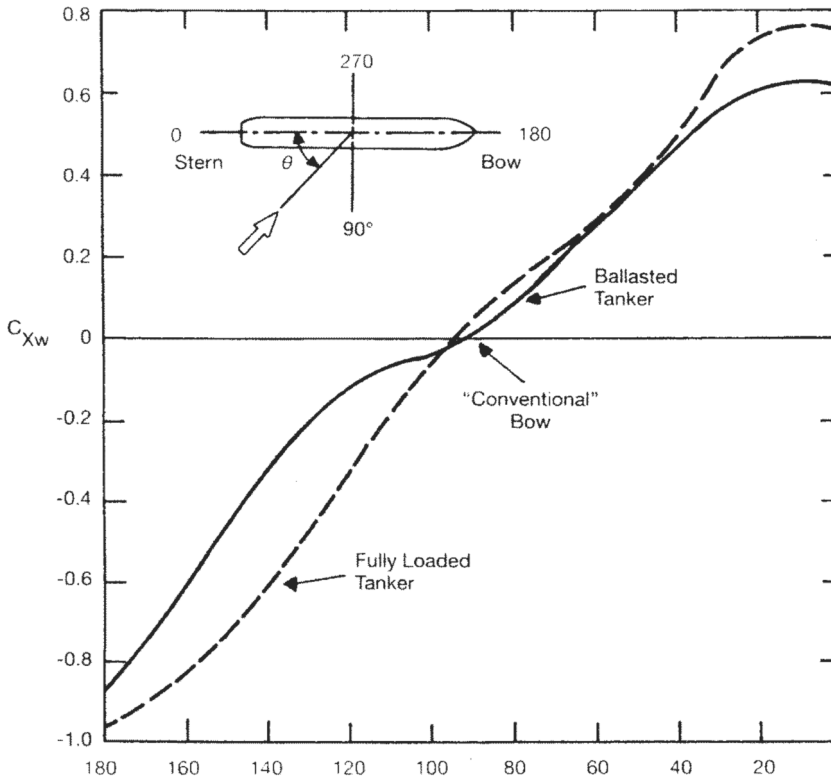

Figure 5.14 Longitudinal wind force coefficient

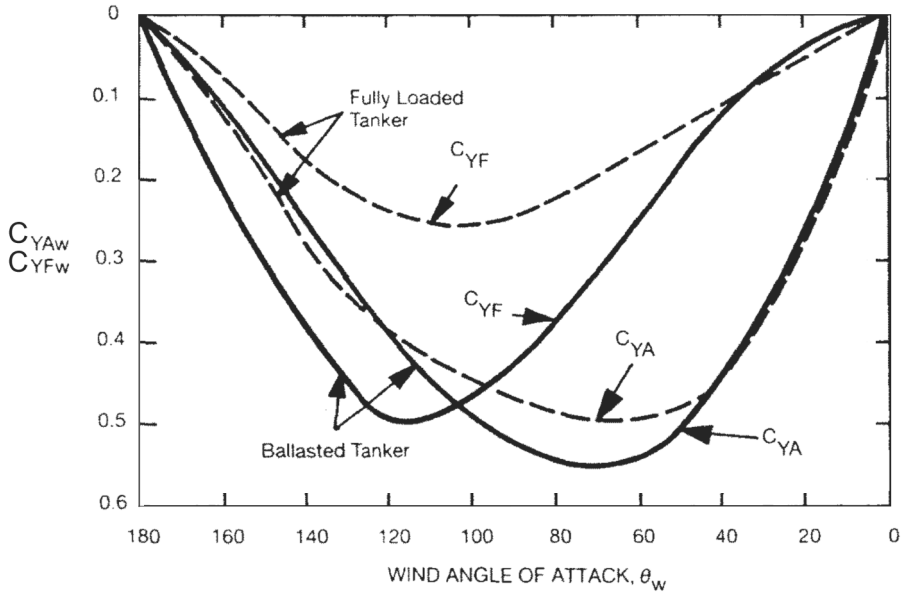

Figure 5.15 Lateral wind force coefficient at the forward and aft perpendiculars

5.3 Approach Channels

The approach channel is defined as the waterway linking the turning circle inside a port (or an open berth at an offshore jetty) with deep water. The three design parameters are alignment, width and depth. Although they are to some extent interdependent, they are treated separately below. The length of the portion between the port entrance and the turning circle is covered in Section 5.4 because it often largely determines the inner areas.

The World Association for Waterborne Transport Infrastructure (PIANC) has published *Harbour Approach Channels, Design Guidelines* that provides a valuable reference (PIANC, 2014). Some of the material here is taken from this report.

The gradually increasing detail of the studies employed in the design, as mentioned in Section 4.3, is reflected in the methods proposed by this PIANC report. This distinguishes two stages, Concept Design and Detailed Design. In the process going from master planning and/or feasibility study to implementation, even more stages and iterations may occur. The main message of Section 4.3 has to be kept in mind: keep the level of detail proportional to the accuracy of input data.

The dimensions of an approach channel are a function of those of the “Design Ship” as shown in the following sections. It should be noted that sometimes more than one design ship has to be defined, for instance one with the largest expected draught for the channel depth and another with the largest height above the water surface to determine the air draught (in case of a channel passing overhead structures such as a bridge).

5.3.1 Alignment

The following (sometimes conflicting) requirements apply to the alignment of an approach channel:

- i. In the case of a dredged channel: the shortest possible length taking into account wave, wind and current conditions
- ii. Minimum cross-currents and cross-wind
- iii. Small angle with dominant wave direction
- iv. Minimise number of bends and avoid bends close to port entrance. The length of straight channel needed before the actual entrance depends on current, wind and wave conditions. In the Port of Rotterdam a length of 6000 m is adopted, but in other ports this length is smaller.

In actual cases the local geometry and bottom conditions play an important role. Hard soil and rock introduce high dredging costs and should rather be avoided.

As long as ships have no tug assistance (which is usually the case for the part of the approach channel outside the breakwaters) the radius of bends depends on the manoeuvrability of the design ship. In water depths normally encountered in a dredged approach channel (1.3 to 1.1 times the ship’s draught) the required radius ranges from a minimum of $4 L_{pp}$

at a maximum rudder angle of 30° to a maximum of $16 L_{pp}$ at 10° rudder angle (see Figure 5.16). A rudder angle of about 20° is a good basis for initial design, leaving some margin of safety. PIANC (2014) provides more detailed information on bend radius as a function of ship type and size.

In the bend the channel width, as determined for the adjacent straight legs, has to be increased because the swept path increases (see Section 5.3.2).

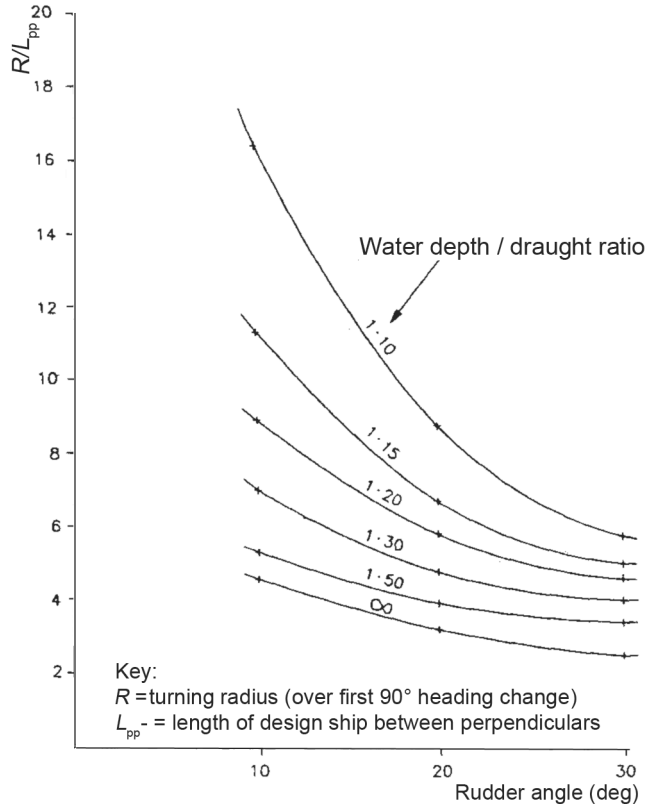

Figure 5.16 Turning radius as a function of rudder angle and water depth

In very busy deep water ports the approach channel consists of a central dredged channel for the largest ships (*channel bound traffic*) and fairways for ships with smaller draught on both sides. In open sea all are separated by traffic separation zones. Figure 5.17 shows the existing system for the Port of Rotterdam.

The boundaries of channels and fairways need to be marked by buoys.

In most ports the approach channel has to be designed for one-way traffic. When the port becomes more busy over time it reaches a point where waiting time occurs too often and becomes too long, and a two-way channel has to be considered. To do this the capacity of channels and fairways needs to be determined by means of a logistic simulation model (Groenveld, 2001). Such a model also allows to investigate the number of ship encounters within the system during a certain period of time. For a busy port marine traffic simulation models are applied to investigate the risk of collisions and measures to reduce this risk, either by introducing more stringent traffic rules or by modifying the layout of the system.

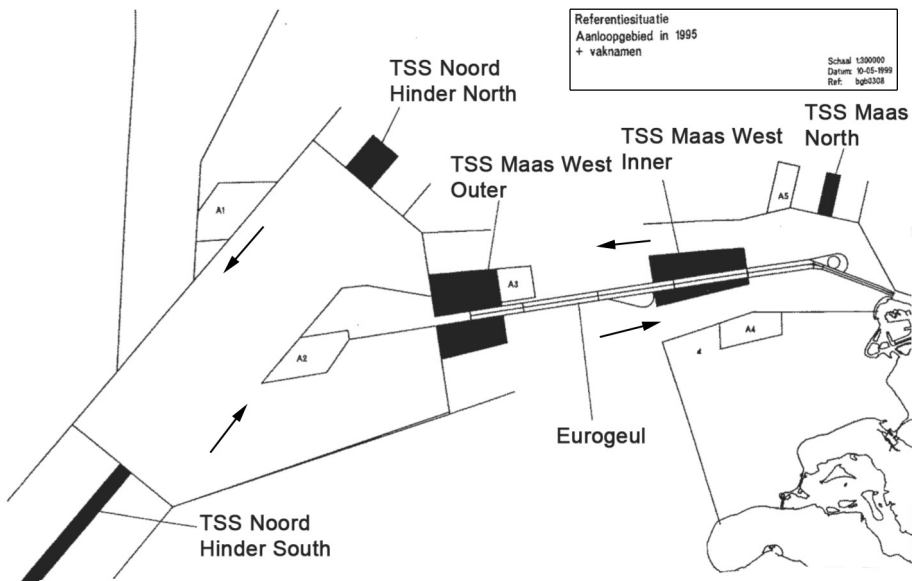

Figure 5.17 Approach channel Port of Rotterdam

Whilst above guidelines are applied for the concept design, a further check and refinement by means of manoeuvring simulation techniques is required, for which a variety of tools is available. Irrespective of what tool or tools are used, the aim is always to assess the viability and risk of navigating with a particular type and size of vessel in a given existing or planned marine infrastructure, in particular physical boundary conditions of wind, waves and currents. Sometimes the risk assessment will have to be quantified in terms of direct and consequential economic damage and/or casualties to comply with local legislation, to achieve overall cost minimization or to confirm a safety level consistent with worldwide port and shipping practice. In any case, manoeuvring simulation constitutes a valuable and indispensable step in present day port planning.

Manoeuvring simulation in its elementary form is performed with a Fast Time Simulator (FTS), consisting of a computer model of the sailing ship under the influence of currents, winds and waves, a monitor to make the operation visible and a track plotter to obtain a record. The ship is programmed to follow a predefined track and the corrective response to any deviations from that track, caused by weather, currents or rudder is automatic and immediate, of course within the manoeuvring capabilities of the vessel. The result reflects the behaviour of a ship controlled by an auto-pilot and this, at the same time, is the limitation of this method.

On the one hand, the auto-pilot will sail a track that it is closer to the predefined track than a human navigator can realize, on the other hand, an auto-pilot cannot anticipate, but a human navigator can. For example, a human navigator, supposedly familiar with local conditions, can anticipate on local strong current changes and can make early mitigative course or speed corrections and thus avoid a dangerous situation, which an auto-pilot cannot. But when used and interpreted by an experienced nautical expert the FTS is quite useful, as it allows a fair comparison of a great number of alternatives in terms of layout and boundary

conditions in a short time and at low costs. Such an FTS is for example the basic SHIPMA model, used extensively all over the world. Because of the limitations inherent to the FTS, the final check on alignment and width of channels and manoeuvring spaces has to be done in a Real Time Simulator (RTS).

Manoeuvring simulation in its ultimate form is performed with Full Mission Real Time Simulators. A state-of-the-art full mission RTS, for example the one developed and operated by MARIN, comprises a full size bridge and controls mock up, mounted on hydraulic cylinders to simulate sailing in waves, a human navigator and helmsman, a very realistically generated 360 degrees outside view adapting itself to the progress of the vessel, manned satellite-simulators to simulate tugboat assistance and even audio effects to make the perception of the whole more realistic. These full mission RTSs have been developed, in the first instance, to train navigators and pilots in how to handle and act in difficult and extreme situations. But they are also very useful to port planners to verify draft final layouts on essential safety aspects. However, it should be born in mind that in as much the stochastic character of the human navigator is involved, a statistical processing of the results is required in order to arrive at conclusions. This means that for each layout and each set of boundary conditions anywhere between 6 and 10 runs have to be made, each taking one to a couple of hours of very expensive equipment and man-power. Thus full mission RTS is a costly affair.

Fortunately intermediate forms of manoeuvring simulators have come into use. For the RTS range of simulators this may involve a human navigator managing the port entry or departure manoeuvre with the aid of a down-sized bridge control panel and the sailed track displayed on a standard monitor. It may also consist of a set up with a bird's eye-view display of the manoeuvring environment adapting itself to the movement of the ship - and the possibility of introducing different secondary effects like the variable forces exerted by tugboats. Being operated real time by a human navigator it also allows to assess in a specific port layout the potential effects of navigation mishaps like loss of rudder control, propulsion failure or total black out which mostly occur during port entry or departure manoeuvres because of the continual changes in engine regime.

With regard to FTS models, a considerable improvement appears to have been made by substituting the simple deterministic auto-pilot by a probabilistic one, thus taking into account the somewhat erratic performance of the human navigator (Jilan, 2010). Further improvements are imaginable if, with artificial intelligence techniques, a self-learning capability could be incorporated into the auto-pilot model allowing it to anticipate on specific situations, more or less as a human navigator.

5.3.2 Channel Width

As explained in Section 5.2.1 a sailing ship makes a sinusoidal track and thus covers a 'basic width', which is about 1.5 times the ship's beam. The effects of wind, current and waves require additional width, but so does the lack of visibility. Moreover, certain margins are needed, that depend on the type of channel bank and the type of cargo. PIANC (2014),

presents a method for concept design, that accounts for all these aspects. For straight sections the channel width is described by the following equation:

$$W = W_{bm} + 2W_b + \sum W_a \quad (5.10)$$

in which:

W_{bm} = basic lane width

W_b = bank clearance

W_a = additional width components

For a two-way channel the separation distance between the two lanes (W_p) is added and this expression becomes:

$$W = 2(W_{bm} + W_b + \sum W_a) + W_p \quad (5.11)$$

The numerical values of each of the parameters are shown in Table 5.1, which is a condensation of the information in the PIANC report, but only for moderate manoeuvrability and slow vessel speed (as this is most relevant for approach channels).

In case of a large tidal range (say in excess of 4 m) the above calculation method is superseded by another consideration, leading to a width in excess of L_s . The reason is that if a ship runs aground on one channel bank, it may turn on the tide and in a narrow channel it may run aground with its stern on the opposite bank. Since channel transit will normally take place around HW , the ship might break at falling tide and block the channel for an extended period.

Regarding the additional width in a bend, it has been mentioned that this depends on rudder angle and water depth over draught ratio. Taking a rudder angle of 20° the swept path of the ship in the bend amounts to $0.35 B$ for a water depth of $1.25 D$. For smaller underkeel clearance this additional width further decreases to $0.2 B$ at $h = 1.1 D$. It is common practice to apply the additional width only in case the adjoining straight leg has a minimum width W_{bm} . When width additions for wind current, etc. are included, these provide for the required space in the bend.

In a previous edition of this book an additional width was related to cargo hazard. In accordance with PIANC (2014) this has been eliminated on the basis that additional safety measures are taken for LPG-, LNG- and chemical carriers, such as speed reduction, VTS assistance, etc.

Table 5.1 Channel width in straight sections

Width component	Condition	Width (m)
Basic width (W_{bm})	moderate manoeuvrability	$1.5 B_s$
Additional width (W_a)		
• prevailing cross winds	15 - 33 kn	$0.6 B_s$
	33 - 48 kn	$1.1 B_s$
• prevailing cross-current	0.2- 0.5 kn	$0.3 B_s$
	0.5- 1.5 kn	$1.0 B_s$
	1.5- 2.0 kn	$1.6 B_s$
• prevailing long current	1.5 - 3 kn	$0.2 B_s$
	> 3 kn	$0.4 B_s$
• prevailing wave height	1 - 3 m	$0.5 B_s$
	> 3 m	$1.0 B_s$
• aids to navigation	VTSS	0
	good	$0.2 B_s$
• seabed characteristics	soft	$0.1 B_s$
	hard	$0.2 B_s$
• depth/draught	1.5 - 1.25	$0.1 B_s$
	< 1.25	$0.2 B_s$
Bank clearance	sloping edge	$0.3 B_s$
	steep, hard embankment	$0.5 B_s$
Separation distance(W_p)	$V_s = 8 - 12$ kn	$1.6 B_s$
	$V_s = 5 - 8$ kn	$1.2 B_s$

5.3.3 Channel Depth

The depth of approach channels depends on a number of factors (see Figure 5.18):

- Draught of the "design" ship, i.e. the ship with the largest draught, which may enter the port fully loaded (larger ships must be lightered before they can enter)
- Other ship-related factors such as the *squat* (sinkage due to ship's speed) and trim (unevenness keel due to loading conditions), heel (unevenness keel due to wind and while turning) and the vertical response to waves (see Section 5.2.2)
- Water level, mostly related to tidal levels. But very long waves and tsunami waves must be taken into account when they occur frequently.
- Channel bottom factors, including the variation in the dredged level and the effects of re-siltation after maintenance dredging.

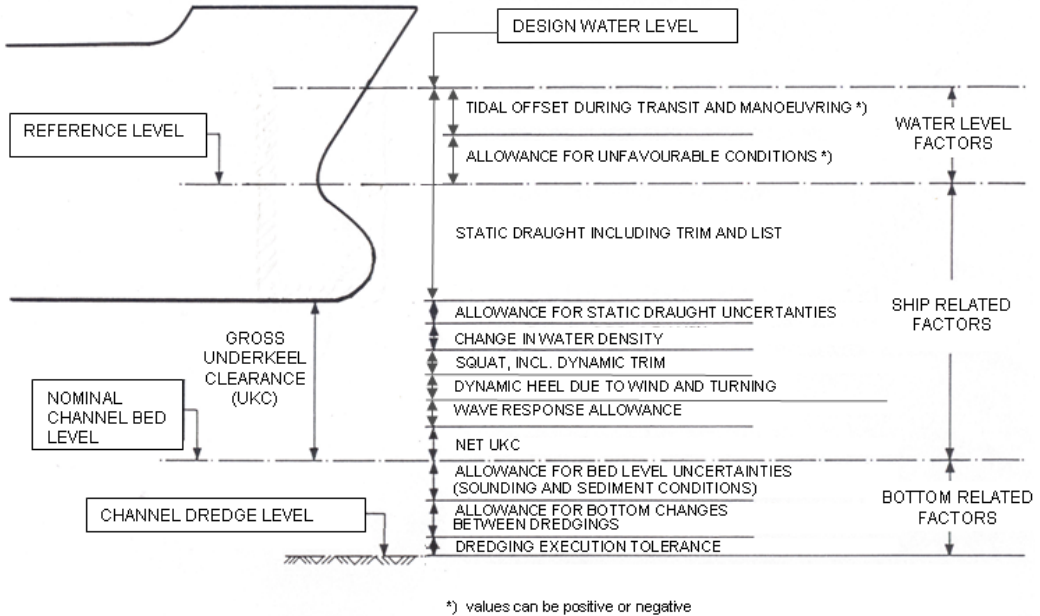

Figure 5.18 Underkeel clearance factors

In a preliminary assessment of channel depth (in the absence of reliable information on waves and ship response) all these factors may be lumped together into one depth over draught ratio taken as 1.1 in sheltered water, 1.15-1.2 in swell up to one meter height, 1.2-1.3 in swell with 1-2m wave height and 1.3-1.4 in higher swell. While such high values may be justified for large ships in long waves (higher response), in conditions without swell it will lead to considerable overdesign. A better method is to determine the various factors separately and to improve the calculation as more reliable data come available. In formula:

$$h_{gd} = D - h_T + s_{max} + z + h_{net} \quad (5.12)$$

in which:

- h_{gd} = guaranteed depth (with respect to a specified reference level)
- D = draught design ship
- h_T = tidal elevation above reference level, below which no entrance is allowed
- s_{max} = maximum sinkage (fore or aft) due to squat, including dynamic trim
- z = vertical motion amplitude due to wave response
- h_{net} = remaining safety margin or net underkeel clearance

In most countries the reference level for sea charts, including port areas, is *Chart Datum (CD)*, often defined as the *Lowest Astronomical Tide (LAT)* during springtide. This is easiest for mariners as in 99% of the time the actual water level is above CD, giving extra safety for their ship. The channel depth in m below CD as shown on a nautical chart is guaranteed by the government or port authority responsible for maintenance. This means that the actual seabed may be decimeters below this guaranteed or nominal level, depending on the maintenance dredging program.

The value h_t is used when a port applies a tidal window: ships may only enter/depart during a certain period around high water. Obviously such a measure reduces the nominal channel depth, but the entry limitation reduces the accessibility of the port.

The values of s_{max} , z and h_{net} together also form the gross under keel clearance or UKC. They may be approximated on the basis of experience: $s_{max} = 0.5$ m; $z = H_s / 2$ (or the amplitude related to the significant wave height therefore assuming a RAO = 1) and h_{net} having a value depending on the type of soil along the channel, 0.3 m for soft mud, 0.5 m for a sandy bottom and 1.0 m for a hard soil or rock.

In addition a “manoeuvrability margin” is specified: the sum of z and h_{net} shall be large enough to guarantee good manoeuvrability. In PIANC (2014) this has been taken as 0.05D or 0.6 m, whichever is greater.

Alternatively s_{max} and z are calculated more precisely. For squat a number of different formulae exist, some of which are applicable in specific conditions only. A general formula for shallow water is given below (Barrass, 2004):

$$s = \frac{C_B}{17.4} k^{0.76} V_s^2 \tag{5.13}$$

in which:

- s = squat [m]
- V_s = vessel speed (rel. to the water) [kn]
- C_B^s = block coefficient [-]
- k = blockage coefficient ($= A_s / A_{ch}$) [-]

Equation (5.13) holds for canals, restricted channels and laterally unconfined water, as shown in Figure 5.19. In the latter case the effective width of the waterway is introduced to calculate A_{ch} :

$$\frac{W_{eff}}{B_s} = \frac{7.04}{C_B^{0.85}} \tag{5.14}$$

There is no sharp distinction between laterally unconfined water and restricted channels. A channel with an underwater bank height less than 40% of the water depth or a width larger than W_{eff} is considered laterally unconfined.

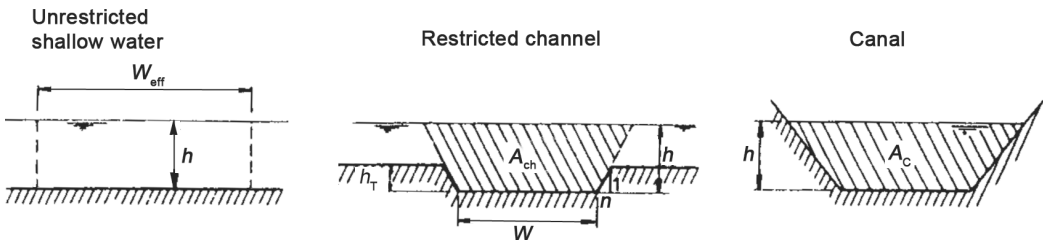

Figure 5.19 Waterway configuration

For the vertical motions in waves PIANC (2014) presents several simplified formulae, but these are found to give very conservative results. The best way to get a more accurate estimate is to obtain the RAO graphs of a range of relevant ship type and sizes in different wave conditions (see Section 5.2.2). This is often done in the detailed design phase.

Equation (5.12) is basically a deterministic calculation with arbitrary values for the stochastic parameter z and for the safety margin h_{net} . Hence the real risk of a ship touching the channel bottom is unknown. In order to avoid possible over-dimensioning the probabilistic method is introduced, whereby depth is calculated for an acceptable probability of bottom touch. In this approach the actual seabed profile can also be included as a stochastic parameter. The design formula then reads as follows:

$$Z = h + h_T - (D + s + z) \quad (5.15)$$

in which h (= channel depth to reference level including dredging tolerance and the effect of resiltation), h_T and D are deterministic. For the parameters s and z the probability density function needs to be determined. Subsequently the probabilistic analysis is made on Level II or Level III for the probability of bottom touch:

$$\Pr(Z < 0) = \alpha$$

This approach was for the first time successfully applied for the depth optimisation of the Euro-Maas Channel to the Port of Rotterdam in the nineties of last century. The design ship is the Berge Stahl (and a few bulk carriers with similar draught). Based on extensive studies on risk of damage to the ship the following criteria for bottom touch were defined (Savenije, 1996):

- i. During 25 years the chance of touching the channel bottom with not more than minor damage must not be more than 10%.
- ii. The chance that a vessel during its transit touches the channel bottom must always be less than 1% for all weather conditions.

The optimum depth of the channel is then determined by minimizing the sum of dredging costs (capital and maintenance dredging) and the demurrage costs of vessels that can not pass under the given conditions.

To conclude, we mention three aspects that are related to the channel depth designs, namely the (vertical) tidal window, the concept of nautical depth and specific effects.

i *Tidal window*

It is emphasised that for channels subject to tidal motion not all ships need to be able to enter or leave port at all stages of the tide. On the contrary, it will often be more economic to restrict the navigability of the channel, at least for the largest ships, to a limited period of the tide, the so-called tidal windows. This mostly refers to the vertical tide, but it may also apply to limiting tidal currents, i.e. to the horizontal tide (in addition, many ports have a wave window: wave conditions beyond which port entry

is not permitted either for safety of the vessel itself, or due to the impossibility of pilots to board vessels).

The type and number of ships involved and the applicable extent of restrictions - i.e. the width of the tidal windows - has to be studied from case to case. It will normally be determined on basis of a minimisation of the sum of channel construction and maintenance costs and ship waiting costs. In actual practice there are often considerable hidden waiting costs, because ships tend to reduce speed well in advance of the harbour entry, rather than to have to wait at an anchorage.

When designing an approach channel with tidal windows the length of the channel and ship speed have to be taken into account as shown in Figure 5.20. In fact, the window needs to be defined at the beginning of the channel in such way that ships entering within the window can traverse the length of the channel safely at a normal speed. In case of emergency (motor failure or a collision) there have to be anchorages along the channel, the last one close to the port entrance.

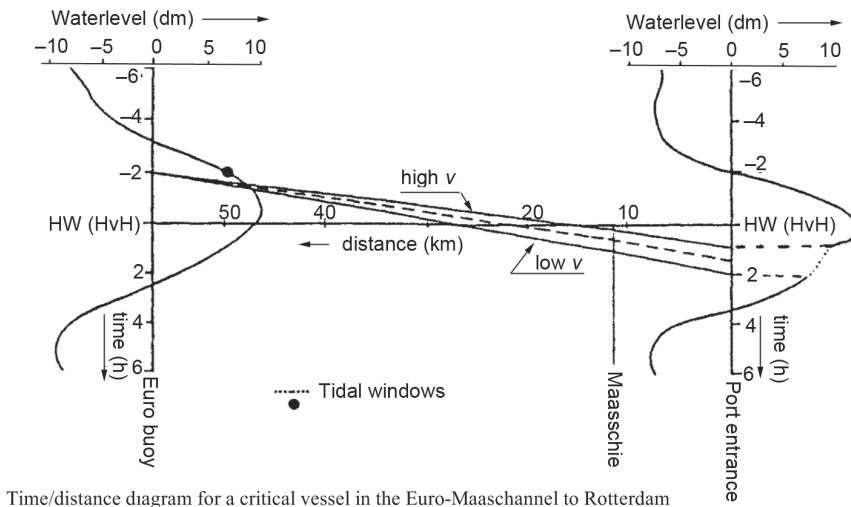

Figure 5.20 Vertical tidal window

It is a logical step to introduce probabilistic design in the calculation of tidal windows: for a class of deep draught vessels with known characteristics, and certain classes of tide- and weather conditions, the opening time and duration of the tidal window is predicted by means of probabilistic calculations using the applicable criteria for bottom touch and manoeuvrability. This approach has in recent years evolved in an on-line computation of the tidal window for each specific vessel just before arrival or departure, using the actual loading, tidal, current and wave conditions. An example of this approach is the Dynamic UnderKeel Clearance (DUKC) method (O'Brien et al, 2012).

ii Nautical depth

If the bottom of the waterway is covered with a non-consolidated, liquid layer of mud, a clear definition of the depth of the channel does not exist. Moreover the meaning of underkeel clearance changes, because there is no danger of damage to the ship when it

sails through the upper part of the mud layer. The solution lies in defining the "nautical bottom" at a level, where its physical characteristics reach a limit beyond which contact with a ship's keel causes either damage or unacceptable effects on controllability and manoeuvrability. Accordingly nautical depth is defined as the vertical distance between the nautical bottom and the free water surface.

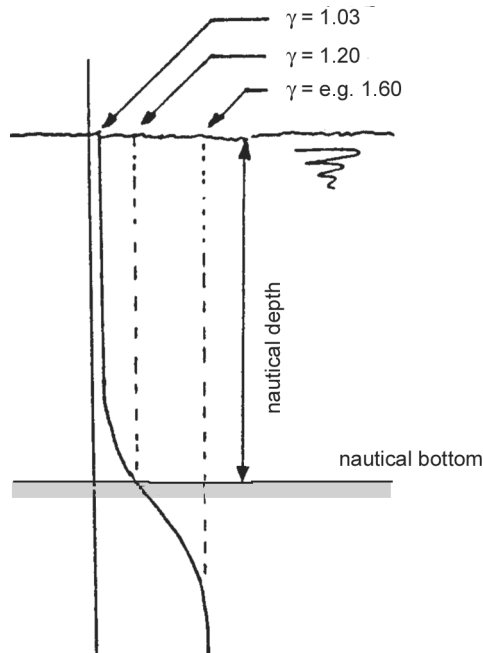

Figure 5.21 Definition of nautical depth

The above concept was subject of extensive studies both in laboratory and at sea in The Netherlands and Belgium, for the purpose of optimising the maintenance dredging volumes in the Europoort and Zeebrugge channels (PIANC, 1983). Without going into great detail the outcome was to define the nautical bottom at a certain density of the fluid mud layer, see Figure 5.21. The density of 1200 kg/m^3 was determined for the Port of Rotterdam, but in other locations slightly different values may be specified. In PIANC (2014) it is explained that the manoeuvrability of ships in muddy channels is in fact dependent on the rheological behavior of the mud, i.e. the shear resistance. This property is determined by many other parameters than the mud density and consequently the relation between both varies a lot. For sake of simplicity the density of 1200 kg/m^3 is still maintained in most ports with muddy bottoms in the channels and the (turning) basins.

iii Specific effects

A ship's draught will be temporarily increased by turning in channel bends. Also cross winds may increase the draught at the bilge keel. These effects are called dynamic heel. Especially car carriers and container ships are sensitive to this effect and heel angles of 3° have been observed. For a B_s of 50 m this means already some 1.3 m increase of draught.

Squat will also be temporarily increased if ships pass each other, particularly in confined waterways. For example, a typical squat value for large containerships in the Panama Canal is 4ft which will double to 8 ft when two such ships pass each other en route. This has immediate consequences for the design depth of relevant channels and canals.

For methods to calculate these special effects reference is made to PIANC (2014).

5.4 Manoeuvring Areas within the Port

The manoeuvring of small size vessels generally poses no special problem in the sense that specific measures have to be taken in the dimensioning of the port infrastructure. The required stopping lengths are limited (see Section 5.2.1) and can usually be accommodated in conventionally sized inner channels and manoeuvring spaces. Manoeuvring capability of these vessels is generally good, and upon entering port they will often manoeuvre and stop under their own power.

For large ships the situation is different. Because of their much longer stopping distance and because of the lack of course control during the stopping manoeuvre, they will mostly not be allowed to stop under their own power. This may already apply to vessels of approximately 50,000 t and over. This means that as long as no effective *tugboat control* is available, such ships have to maintain a certain minimum speed relative to the water, at which there is still sufficient *rudder control* available. This speed is about 4 kn, sometimes slightly less.

The number and capacity of tugs depend on the size of the vessel. For ships of about 50,000 t two tugs will be sufficient, one operating forward and one aft. But for large container ships, VLCC's and large bulk carriers 3 to 4 tugs are required. The capacity is expressed in maximum bollard pull provided by a tug. The total bollard pull T_B is derived from the ship size by means of the following expression:

$$T_B = \frac{\Delta}{100,000} \cdot 60 + 40 \quad (5.16)$$

in which:

Δ = Ship displacement (t)

E.g. a 200,000 t tanker, with a displacement of 240,000 t will require a total bollard pull of about 180 t. This can be provided by 3 tugs with 60 ton capacity or 4 tugs with 50 ton.

The stopping length becomes an important aspect for the port lay-out, when the design ship requires an entrance speed above the minimum value and/or the wave climate outside the port is such that tugs cannot make fast for considerable periods of time. The latter situation occurs for $H_s > 1.5$ m (possibly increased to $H_s > 2$ m by use of larger tug boats). This condition is not only dictated by the feasibility of getting the towing lines across, but also by the safety of personnel in view of the high chance that the lines, once fastened, will break due to opposite horizontal movements of ship and tug.

The slowing down and stopping length is then required within the protection of the breakwater, i.e. in relatively sheltered water with little or no currents, and is determined by the factors:

- a. Entrance speed of the ship
- b. Time required to tie up the tugboats and to manoeuvre them in position
- c. Final stopping length

sub (a) The *entrance speed* is basically determined by the requirements that the vessel should have sufficient speed with respect to the surrounding water for proper rudder control, say 4 kn, and/or that the drift angle should not exceed a tangent of about 1:4. The first requirement implies that if there is a following current near the entrance of e.g. 2 kn, the minimum entrance speed will be 6 kn. The second condition implies that if there is a cross current of 2 kn, the minimum entrance speed will be 8 kn. See also Figure 5.22. The length needed to slow down is taken as:

$$L_1 = (V_s - 2) \cdot \frac{3}{4} L_s$$

sub (b) The time required for tying up tugboats depends very much on the expertise of the crews and the environmental conditions. In average circumstances this time will be in the range of about 10 minutes. The corresponding length amounts to $L_2 = 10 \cdot 60 \cdot 2 = 1200$ m, assuming that the ship maintains its minimum speed of 2 m/s during making fast.

sub (c) The *final stopping distance* is relatively short. The large ships give astern power the moment tugboats can control the course and, subsequently, stop in about $1.5 L_s$ from a speed of 4 kn (L_3).

The total length within the protection of a breakwater thus becomes:

$$L_{tot} = L_1 + L_2 + L_3$$

The consequence of the above requirements is that – in case of adverse wave climate- the length of the inner channel easily measures 2.5 km or more, if the port wants to be able to receive large ships under acceptable standards of *nautical safety*.

In case of a captive port facility for dry or liquid bulk additional stopping length due to cross-current is eliminated by applying a horizontal tidal window, i.e. the ship may only enter when the tidal currents are below a certain value. For busy commercial ports this solution is often unacceptable, because of the inherent limitations of access and resulting waiting time.

Note: in the Euro-/Maasgeul (Port of Rotterdam) and IJ-geul (Port of Amsterdam) a horizontal tidal window has been introduced for the largest vessels, not for reasons of reducing the stopping length, but to achieve safety in more general.

Drift of the ship under influence of current and wind

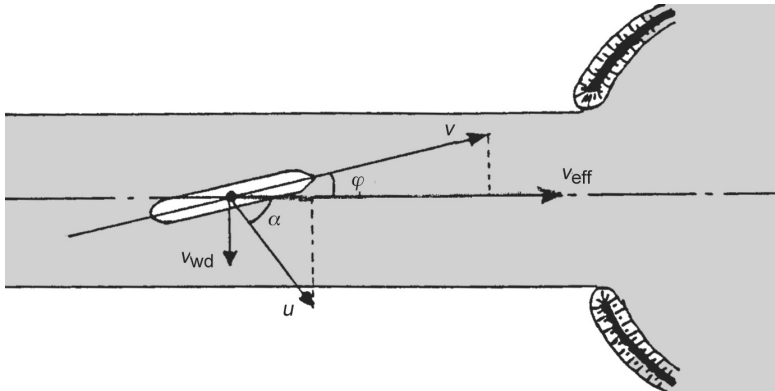

Figure 5.22 Drift of the ship under influence of current and wind

V	=	ship speed with respect to water
V_{min}	=	minimum ship speed for rudder control (4 kn)
V_{eff}	=	ship speed with respect to channel bottom (design entrance speed)
u	=	current velocity
V_{wd}	=	transverse speed of ship as result of wind drift
φ	=	drift angle
α_{axis}	=	angle between current and channel axis

In Figure 5.22 the ship has to maintain an angle with the channel axis in order to counteract the forces due to current and wind. This drift angle is limited to about 14° because for greater angles the rudder control reduces too much.

The ship sails along the channel axis with a speed with respect to the channel bottom V_{eff} which is calculated by either of the two equations:

(i) minimum speed can be maintained, without too much drift angle,

$$V_{eff} = V_{min} \cos \varphi + u \cos \alpha$$

$$\text{provided that} \quad \tan \alpha \leq 1/4$$

or

$$V_{min} = \cos \varphi + u \cos \alpha \geq 4(u \sin \alpha + V_{wd})$$

(ii) the maximum permissible drift angle dictates the ship speed

$$V_{eff} = 4(u \cos \alpha - V_{wd})$$

The width of the inner channel is determined using the same guidelines given in Section 5.3.2. Obviously, width additions for current and waves do not apply, because these are eliminated by breakwaters. Where ships enter under influence of cross-currents, additional space is required immediately behind the breakwaters. Upon entering the drift angle has a tendency to increase because the bow of the ship is moving out of the current and the moment on the ship increases. An experienced captain or pilot will anticipate this movement by giving some rudder in opposite direction. In practice allowance is made for this aspect by extending the outside channel width for $2-3 L_s$ inside the breakwater before narrowing to the inside width (see Figure 5.23).

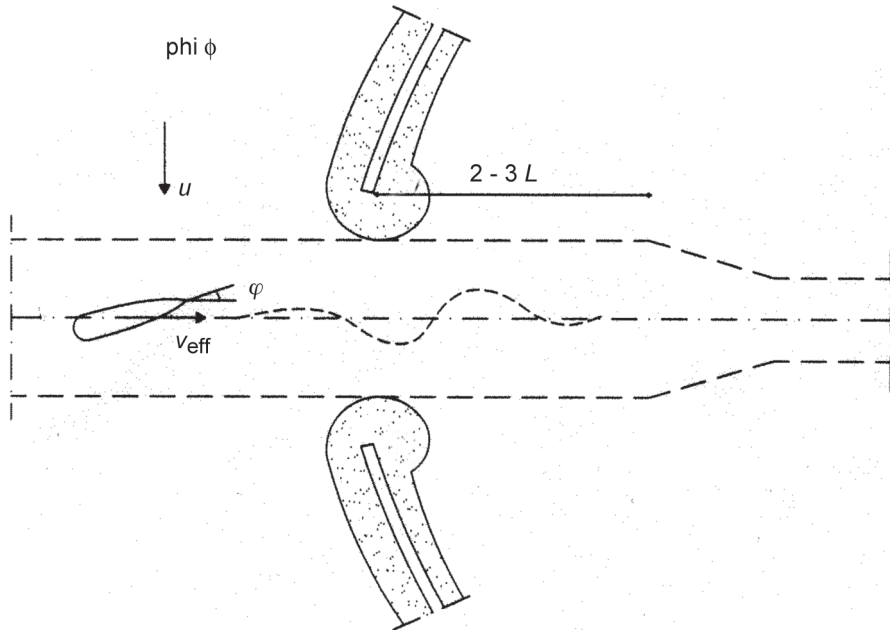

Figure 5.23 Port entrance manoeuvre

The *inner channel* should end in a turning basin or circle, from where vessels, whether small or big, are towed by tugboats to their respective basins. The diameter of this turning basin should be $\geq 2 L_s$. Where available space is limited, this requirement can be relaxed by increasing the number/size of tugboats. This shall always be verified by means of simulations. In case of currents, for instance in river ports, the turning basin should be lengthened to compensate for vessel drift during manoeuvring.

The length, width and lay-out of the inner channel can be optimised in a similar way as the width of an approach channel, viz. by fast-time manoeuvring simulations initially, and by a full-mission real-time simulator ultimately (see Section 5.3.1). Also here, the stochastic nature of human navigator performance plays an important role.

5.5 Port Basins and Berth Areas

5.5.1 Nautical Aspects

Port basins should be given a sufficient width for the safe towing in and towing out of the vessels, whilst other berths are occupied. For conventional cargo and container ships, this

results in $4 \text{ to } 5 \cdot B_s + 100$ (Figure 5.24). If $B_s = 25$ m (conventional general cargo ship), this means a basin width of some 200 to 225 m; if $B_s = 59$ m (Ultra Large Container Ship), the basin width should be in the range of 340 to 395 m.

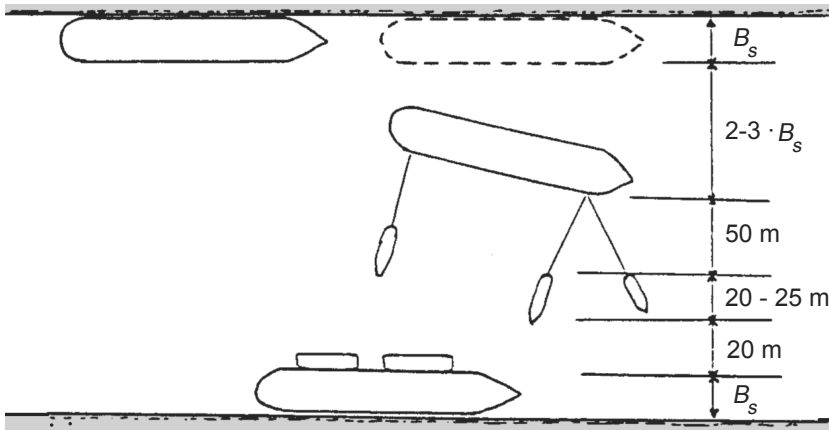

Figure 5.24 Basin width

In case of very long basins, say 1,000 m or more, it is desirable that ships can be turned in the basin. The required width is about $L_s + B_s + 50$.

For big tankers or bulk carriers, the desirable basin width - also for two-sided use of the basin- is $4 \text{ to } 6 B_s + 100$ m. The lower value applies to favourable wind conditions, the higher to frequent and strong cross-winds. For $B_s = 45$ m, $5 \cdot B_s + 100$ m results in a basin width of 325 m.

Not to be overlooked in planning the port basins is a separate area for the small craft, i.e. tugs, flats and pilot launches. Because of their size these vessels are more sensitive to wave disturbance and hence the location of the small craft harbour must on one hand be well protected and on the other hand not too far from the port entrance, where they have to pick up incoming ships and let go the departing vessels. Sometimes this is achieved by creating a separate basin (with the appropriate depth) protected by its own breakwater. The berth length and basin surface area required depends on the number of tugs and other small craft (see also Section 5.4).

Regarding the berth orientation, wave, wind and (in case of offshore or river berths) current conditions play a role. Ideally for safe berthing, the berth should be aligned within about 30° of the prevailing wind direction. Currents alongside the berth should be limited to 3 kn and perpendicular to the berth no more than 0.75 kn (OCIME, 1997).

5.5.2 Wave Agitation

Waves within the boundaries of a port may have been generated locally, or have entered from outside. Due to the limited fetch locally generated waves will generally be smaller and have short periods. But, some ports do have a fetch for specific wind directions which cannot be neglected, e.g. Rotterdam, New York, the Mersey ports in the UK, Bombay and the south-western part of the port of Singapore. If the fetch is, for example, in the 5 to 10

km range, wave heights (H) will be somewhat in excess of 1 m for a Beaufort 7 wind, and some 1.7 m for Beaufort 9, with periods T of 3 to 3.5 s. Since, moreover, these waves can be very steep, they will hamper harbour tugs and similar craft, but large sea-going vessels will not be affected at all.

Wave penetration into a harbour mostly takes place through the harbour entrance. However, also the overtopping of low-crested breakwaters or wave transmission through permeable breakwaters - the latter particularly for long period waves - may contribute to wave agitation within the port. For example, in the outer harbour of the port of Visakhapatnam on the Indian east coast, wave transmission through the quite permeable southern breakwater is an important cause for the local wave problems.

It is crucial to assess the magnitude of these phenomena at the design stage of the breakwater(s), as it is difficult to devise suitable means to reduce wave penetration once the breakwaters have been built.

In general terms, the problems encountered to limit wave penetration in a harbour increase with increasing wave period. In this respect, an ocean swell with a period in the order of 12 to 16 s is already more difficult to protect against than wind waves of 6 to 8 s period. For still longer wave periods, as applies for seiches with a period of 2 to 3 min or more, the only solution often is to minimise resonance in the design of the port's water areas (see Section 5.5.3).

The port lay-out has to satisfy two different requirements as far as wave penetration is concerned: (i) operational conditions must allow efficient loading and unloading of the ships at berth, and (ii) for limit state conditions the ship must be able to remain at berth safely.

(i) Operational conditions

In the preliminary design stage (master plan or feasibility study) the wave penetration for operational conditions is often estimated on the basis of hand-calculations (Cornu or the wave penetration diagrams in the Coastal Engineering Manual) or simple computer models. The criteria at the various berth locations are in that case given as allowable wave heights for unloading/loading for the relevant ship types (see Table 5.2). It is clear that the wave height criteria are quite crude, because the wave periods and the effects of the mooring system on ship movements are not taken into account. For detailed design of the port lay-out not only more accurate wave penetration models are applied, but wave heights are translated into ship motions. Therefore the design has to fulfil operational criteria in terms of ship movements in the relevant modes (OCIMF, 1997 and PIANC, 1995). Table 5.3 gives a summary for different ship types.

Table 5.2 Limiting wave height H_s

Type of vessel	Limiting wave heights H_s in m 0° (head or stern)	45° - 90° (beam)
General cargo	1.0	0.8
Container, Ro/Ro ship	0.5	
Dry bulk (30,000-100,000 t); loading	1.5	1.0
Dry bulk (30,000-100,000 t); unloading	1.0	0.8 - 1.0
Tankers 30,000 t	1.5	
Tankers 30,000 - 200,000 t	1.5-2.5	1.0 - 1.2
Tankers 200,000 t	2.5-3.0	1.0 - 1.5

Table 5.3 Allowable ship motions

Type of vessel	Surge (m)	Allowable motion amplitudes		
		Sway (m)	Yaw (°)	Heave (m)
Tankers	2-3	2-3	1	1.5
Bulkers	0.5-1.5	0.5-1.0	-	0.3-0.5
Container ship	0.5	0.3	1	0.3
Ro/Ro ship	0.3	0.2	0	0.1

Some clarifications apply to the values of Table 5.3:

- The allowable surge and yaw motion of tankers is much higher because the ships are (un)loaded at a central manifold amidships. In detailed design of the berth the type of loading arm determines the allowable motion in last instance.
- The motions of a containership are more critical because of the high precision needed for (un)loading containers and the delays when the container gets stuck in the cell guides.
- Ro/Ro ships are particularly sensitive to ship motions due to the ramp connection with the quay.

The ship motion analysis is performed with advanced computer models, as outlined in Section 5.2.2. A typical example of the results of such a computation is given in Figure 5.25.

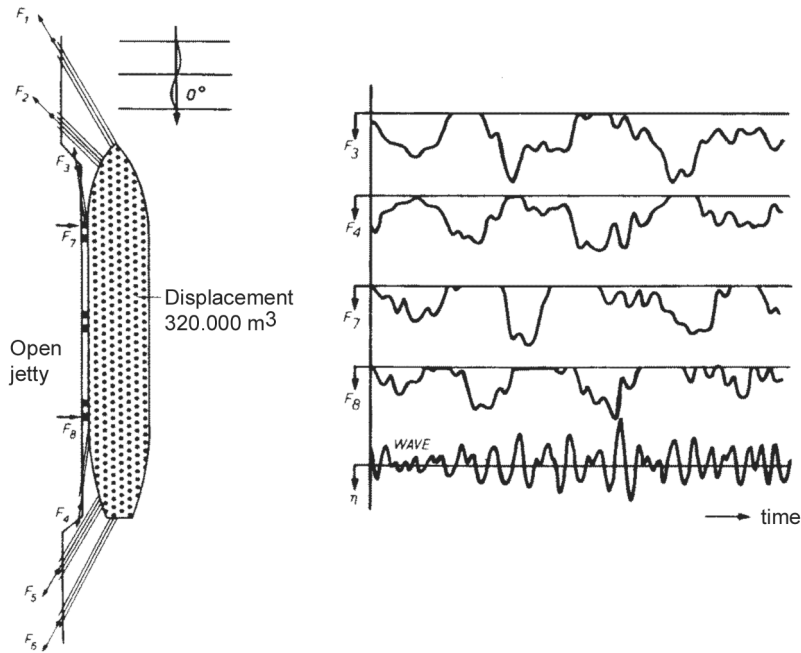

Figure 5.25 Fender and mooring line forces for a tanker in head waves (source: Deltares)

Note: apart from wave conditions also the wind conditions may limit operability. In particular container terminals are sensitive to wind, firstly because it affects the crane productivity and secondly because a strong wind parallel to the quay endangers the stability of the cranes. In ports that experience hurricane/typhoon wind conditions it has happened that cranes were not locked to the rails in time and started to roll due to the high wind speeds, leading to enormous damage.

(ii) *Limit state conditions*

For wave heights above the operational limit the (un)loading of the ship is interrupted, but the ship remains berthed till limit state conditions are reached. In ports, where wave disturbance does not play a role (e.g. ports behind locks or upriver) this condition does not occur and ships can stay inside even in extreme weather. Many of the older ports are examples of this *fugitive* type. Most newly developed ports cannot afford to be fugitive and a limit state condition is determined as a trade-off between costs for breakwaters and shipping cost related to the loss of time due to the ship having to leave berth. In case of an offshore berth the limit state may be chosen at a 1/yr wave condition, while in case of an enclosed harbour basin a 1/10 yr sea state may be more appropriate. In all cases the forces in the mooring lines and fenders have to be within the allowable limits. An interesting aspect here is that the fenders can be designed strong enough, but that the number and allowable strength of the mooring lines are often the determining factor. To determine the line and fender forces requires again computer calculations (see Section 5.2.2) or even physical models in case of a complex geometry of the port and/or

the seabed. More details on types of mooring lines and fenders and their characteristics will be outlined in Chapter 10.

5.5.3 Harbour Basin Resonance

In case the period of the incident waves equals or approximates the natural period of oscillation of a harbour basin, resonance phenomena will occur. This may lead to locally much higher waves and, consequently, to more severe problems for ships at berth. If a harbour basin has a more or less uniform depth and rectangular shape, the natural periods of oscillation T_n are as follows (see Figure 5.26):

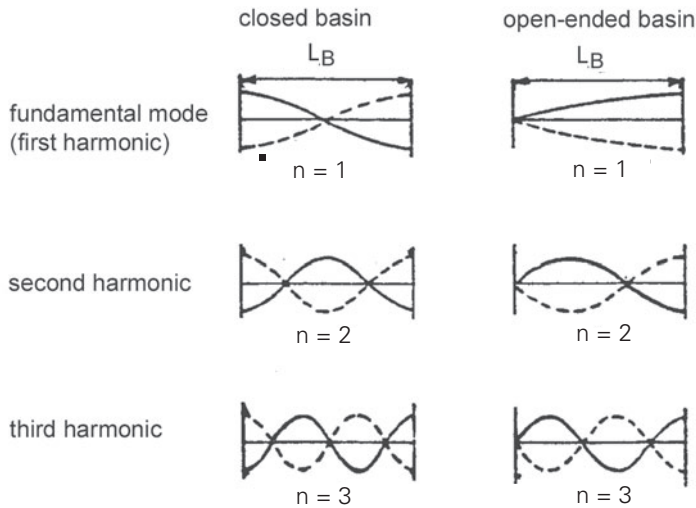

Figure 5.26 Basin oscillation

Closed basins

$$T_n = \frac{2 \cdot L_B}{n} \cdot \frac{1}{\sqrt{gD}}, \text{ with } n = 1, 2, \dots \quad (5.18)$$

open ended basins

$$T_n = \frac{4L_B}{2n - 1} \cdot \frac{1}{\sqrt{gD}}, \text{ with } n = 1, 2, \dots \quad (5.19)$$

The closed basin condition would apply to basins with a very narrow entrance and to transverse oscillations.

In case of a more complex geometry of the basin boundaries and variable depths, mathematical models have to be used to determine the T_n in different basins.

This phenomenon should be avoided or minimised in the planning stage, i.e. by checking the selected lay-out and if necessary by modifying it. Changing the size of harbour basins

often is not effective, because resonance then occurs for a slightly higher or lower wave period. The best approach is to avoid regular shapes (*organ pipes*) and to introduce damping boundaries, where possible.

The problem of harbour resonance is particularly manifest along the borders of oceans, because of the long period swell ($T_p = 10-16$ s) and the occurrence of long waves with periods ranging from 30-300 s. Although the latter waves have small amplitudes, when creating resonance they can become a nuisance. An additional factor is that such long waves easily pass through rubble mound breakwaters, if their core is slightly porous. The third measure to avoid resonance is therefore to make the core of the breakwaters as impermeable as possible.

In case harbour resonance occurs once the port is constructed it is more difficult to reduce the problem. Placing additional (impermeable) breakwaters close to the entrance to the basin is one method. Care should be taken that navigation is not impeded by the new structures. Another measure is to create additional damping at the closed end of the basin, but this is often conflicting with terminal functions. Moreover the dampening effect of a spending beach on long period waves is very limited. In such cases it is easier to provide additional, stiff mooring lines from the quay-side to reduce the effects of the resonance on the ship motions. A new development in ship mooring, the so-called vacuum pad which restrains the horizontal ship motions, will be attractive in this respect.

5.6 Morphological Aspects

In three different ways morphological processes affect the port lay-out:

- i. The effect of a coastal port with breakwaters on the natural littoral transport, often resulting in accretion and erosion of the adjacent coastlines.
- ii. Siltation in the approach channel and in the area close to the port entrance, leading to maintenance dredging.
- iii. Sediment transport into the port area leading to deposition and maintenance dredging.

5.6.1 Littoral Transport

In Section 4.4.4 the function of the breakwater to intercept littoral transport was mentioned. In determining the length of the breakwater(s) two criteria apply:

- (i) The width of the breaker zone. This varies, however, with the deep water wave height (in first approximation the breaker depth $d_b = 1.6 H_s$) and the question must be answered what frequency of storms is taken as criterion in this respect. A compromise is sought between very low frequency of occurrence leading to long breakwaters but minimum siltation, and a high frequency with short breakwaters and much maintenance dredging. As a first approximation the annual wave condition is often used, but in a design optimisation the minimum of capital construction cost + maintenance/dredging cost has to be determined.

(ii) The storage capacity at the side of the breakwater from which littoral transport comes. Again it is an economic question in which the sum of the costs of breakwater and of maintenance dredging has to be minimised. But it is also a matter of guaranteed depth of the approach channel. The process of accretion on one side may, in the case of relatively short breakwaters, fill up the triangle between the original coastline and the breakwater, after which littoral transport continues. This will cause accelerated siltation in the approach channel as shown in many existing ports (see Figure 5.27). If this shoal reaches above charted depth (see Figure 5.18), the access of the largest ships would be blocked, which clearly is not acceptable.

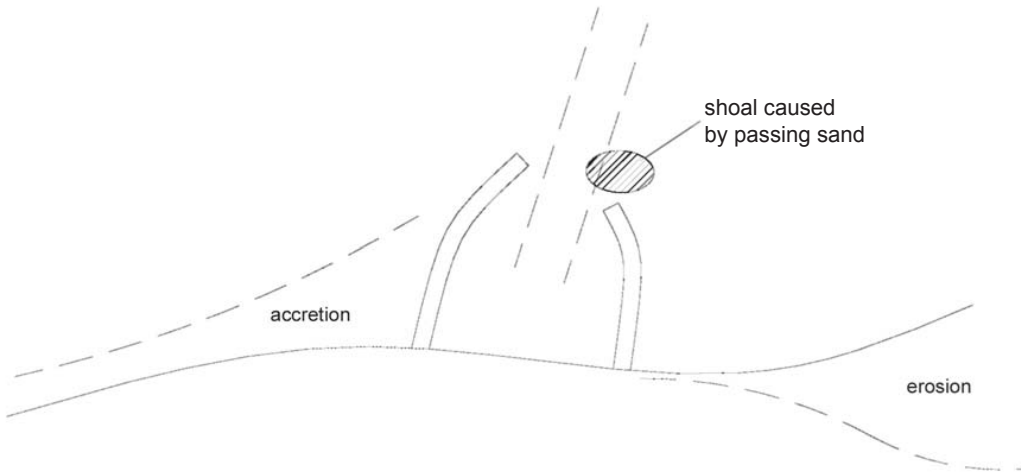

Figure 5.27 Effects of the port on littoral transport

For the port planner this means the following:

- If there is substantial transport in both directions the port needs two breakwaters, reaching to sufficient depth to avoid that the instantaneous transport is deposited in the approach channel and harbour basins.
- If the littoral transport is predominant in one direction, one breakwater may be sufficient (but the eddy at the leeside of this breakwater may still deposit sediment, which is undesirable).
- In both cases above the breakwater at the side whence the net annual transport comes from, has to be long enough to minimize by-passing sand to cause rapid siltation of the channel (instead of making the breakwater longer it is possible to design an artificial sand by-pass). The head of the second breakwater has to be positioned in such way that by-passing material is not drawn into the port, even if this is conflicting with nautical requirements (see Figure 5.28).

The methods for calculating littoral transport, rates of erosion and accretion, and deposition rates in and around the approach channel are not treated in this book.

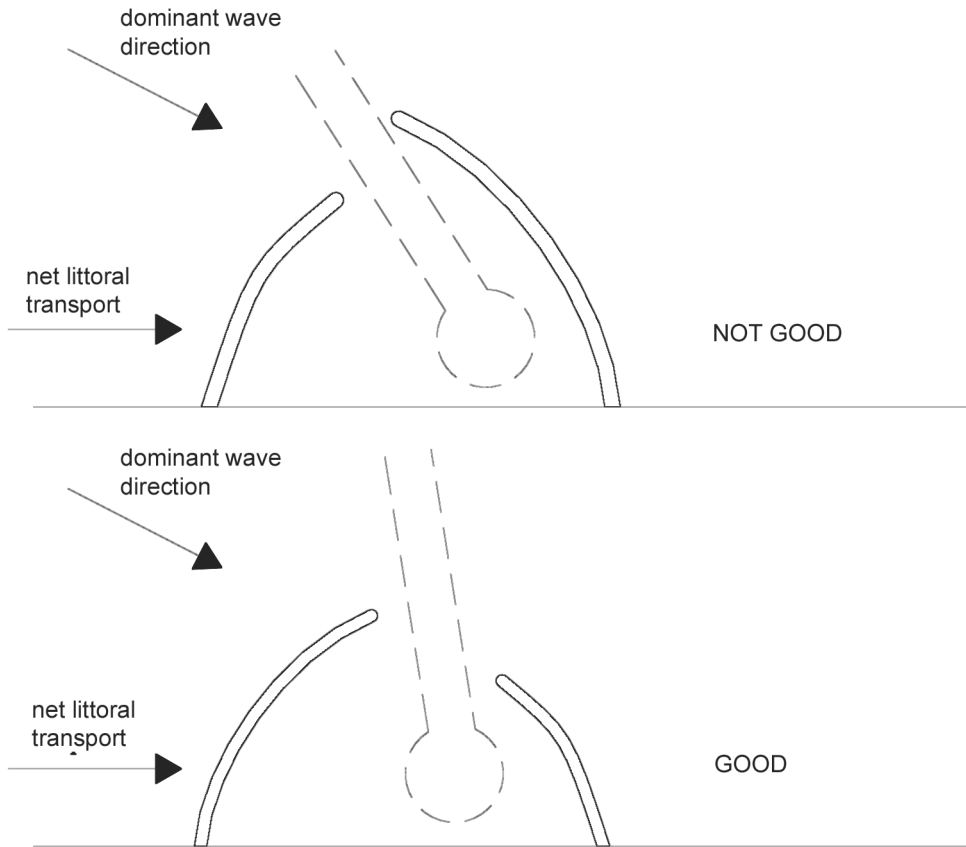

Figure 5.28 Lay-out of breakwater heads in relation to littoral transport

5.6.2 Siltation of Approach Channels

Siltation in the outer channel can also be caused by settlement of sediments due to the increased depth or reduced current velocities. This mechanism becomes an important factor for channels located in coastal areas with fine material at the seabed, in estuaries or when a natural river has been deepened to allow larger ships to reach an upstream port. Examples are the Nieuwe Waterweg in Rotterdam, which was deepened from a natural depth of about NAP -6.0 m to -17.0 m at present, the channel to the port of Shanghai (from CD -7.0 m to -12.5 m) and the shipping channel in the muddy La Plata delta in Argentina, from CD -5.5m to CD -9.0 m.

Computer programs are available to analyse the complex process of settlement and condensation of cohesive sediments.. Here an empirical method is mentioned, which is particularly useful for channels extending far into silty or muddy areas or in cases, where the natural riverbed is deepened to allow shipping. In such cases the annual siltation volume per meter channel length may be estimated as a percentage of the overdepth (the difference between the new design depth and the natural depth).

$$V_d = C_r \cdot W \cdot h_{over} \quad (5.20)$$

in which:

$$\begin{aligned} V_d &= \text{average annual volume of resiltation [m}^3\text{/m/year]} \\ C_r &= \text{resiltation factor [m/yr]} \\ W &= \text{channel width [m]} \\ h_{over} &= \text{overdepth [m]} \end{aligned}$$

The *resiltation factor* may be derived from an existing approach channel along the same coast or by comparing the morphological conditions with similar situations elsewhere in the world. Analysis of maintenance dredging volumes in major approach channels has shown that values of C_r between 0.5 and 0.7 m/yr are quite common and in the La Plata delta even $C_r = 1.0$ m/yr is found.

The method is useful for preliminary assessment because it allows taking the consequences of (high) maintenance dredging costs into account in the early stage of concept development. The problem is that, contrary to the littoral transport effects, very little can be done in terms of design to reduce this sedimentation effect. For new to build ports it may lead to reconsideration of the site for port development. And for the deepening of existing channels, it may be more economic to locate the necessary expansion nearer to the coast or even into the sea, where deeper water is available.

5.6.3 Sedimentation inside the Port

Like the previous effect, the sedimentation inside the port area is also often caused by fine sediments entering through the entrance and/or from upriver and settling in the deepened basins and manoeuvring areas. Three mechanisms play a role in the sediment intrusion through the entrance:

- i. The tidal filling of the port.
- ii. *Density currents* at the entrance, where salt (and/or colder) water flows in at the bottom, while more fresh (and/or warmer) water flows out at the surface.
- iii. The exchange of sediment filled water in an eddy behind the breakwater forming the port entrance (see Figure 5.29).

The annual rates of *sediment deposition* due to these processes are reasonably easy to estimate, based on preliminary data on sediment load and schematisation of the hydraulics. Very often various processes act at the same time, in concurrence with sediment flow from upriver. In such cases numerical models are applied for more accurate determination of the resulting maintenance dredging.

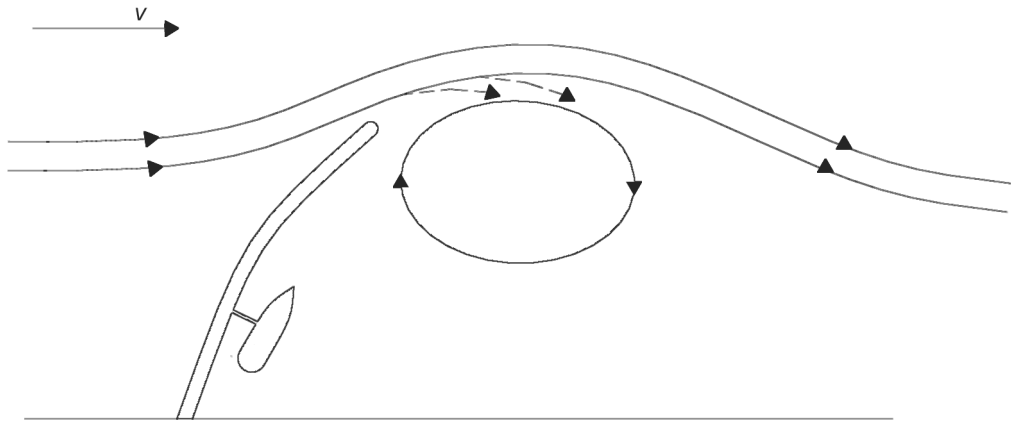

Figure 5.29 Sediment exchange between main current and eddy

5.7 References

- Barrass, C.B., Thirty-two years of research into ship squat, Squat Workshop, Elsfleth/Oldenburger, 2004
- Delefortrie, G., Manoeuvrability of deep draft vessels in muddy navigation areas, PIANC Magazine, Oct. 2008
- Goda, Y and Yoshimura, T., Wave forces on a vessel tied at offshore dolphins, Proc. 13th Int. Conf. on Coastal Engineering, ASCE, 1972
- Groenveld, R., Service systems in ports and inland waterways, Delft Academic Press, 2001.
- Hensen, H., Tug use in ports, Port of Rotterdam Authority/ Nautical Institute, London, 1997
- London Convention, Resolution LC.52 (18) on a Dredged Material Assessment Framework (DMAF), Doc. LC 18/11, Annex 2, 1995
- OCIMF, Mooring Equipment Guidelines, Livingstone, 2008
- PIANC, Criteria for movement of moored ships in Harbours, Report Working Group PTC II-24, Brussels, 1995
- PIANC, Dredged material management guide, PEC Special Report, Brussels, 1997
- PIANC, Harbour approach channels. Design guidelines, Report no. 121, Brussels, 2014
- Vellinga, T., Environmental issues in port development and port operation, Delft Academic Press/VSSD 2004
- Velsink, H., Manoeuvring simulation: a Port Planner's wish, MARIN Jubilee Meeting, Wageningen, 1992
- Vis, F.C. et al, Long Waves and Harbour Design, Proc. Int. Conf. on Numerical Modelling of Ports and Harbours, Birmingham, 1985

Chapter 6

Planning and Design of Port Terminals

6.1 General

Port terminals are those port facilities that constitute the factual interface between different modes of transport of the cargo. For example, from sea going vessel into inland barges, road or rail transport, pipeline or feeder vessel, and vice versa.

There are also IWT (inland water transport) terminals where the cargo is transferred from inland barge or self-propelled vessel to truck or railway wagon, and the other way around. In commercial ports, the terminals are the 'raison d'être' of a port. All other facilities are provided only to enable the terminals to function, and that in a safe and efficient manner. For captive port facilities the terminal is only a necessary element to enable the key process, for instance a refinery or a power plant.

6.2 Services Provided

The services provided by a port terminal normally comprise the unloading from ship to shore, or the reciprocal process, the temporary storage, sometimes a limited processing of the cargo, and the loading or unloading into or from the through-transport means.

Unloading is also quite frequently done by ship-borne gear. This applies to virtually all liquid bulk cargoes for which ship-borne pumps are used. It also applies to some dry bulk cargoes carried by geared bulk carriers or self-unloaders, and to the use of ship's cranes on general cargo or multi-purpose vessels. The loading of bulk cargoes is almost always done by shore-based equipment.

Intermediate storage is not necessarily part of the services, but, in practice, almost always is. Many cargoes need customs checking and/or quality and quantity checks which precludes direct through-transport. However, a more important reason, particularly for bulk cargoes, is the difference in parcel sizes and loading and unloading rates of maritime transport on the one hand, and through-transport on the other. E.g. a very large bulk carrier may unload ore at a rate of up to 5,000 t/hr or 100,000 tonne or more per day, but it is unnecessary, technically almost impossible and very uneconomic to arrange the through transport at the same rates. In other words, an intermediate storage or buffer stock is necessary.

Apart from that, certain clients prefer to locate operational and strategic reserves in the port rather than at the site of production or consumption, which leads to increased storage demands.

The processing that a terminal can offer as a service, usually consists of packing or re-packing, bagging (e.g. grain or fertiliser) or blending (e.g. different grades of ore or coal). More complex forms of processing exist, but are not very common. The 'added-value' ac-

tivities, that are very important for the employment, are mostly done outside the terminals in logistic centres.

6.3 Terminal Components

The components of a terminal are:

- The wet and the dry infrastructure
- The suprastructure
- The equipment
- The human resources

The *wet infrastructure* comprises part or all of a harbour basin in which one or more berths are located to accommodate the ships. The type of berth is largely dictated by the nature of the loading or unloading process (see Figure 6.1). Relatively the most expensive is the *marginal quay* or *wharf* which is a quay connected over its entire length to the terminal area behind it. It thus permits longitudinal as well as transverse cargo movements to and from the storage areas over the full length of the ship. This is a prerequisite for the efficient handling of all non-bulk cargoes. Marginal quays are also often used for large dry bulk terminals when heavy gantry cranes have to be able to travel alongside a ship for unloading purposes. (Particularly for dry bulk cargoes, berths for loading and unloading respectively may be quite different because of the different equipment used).

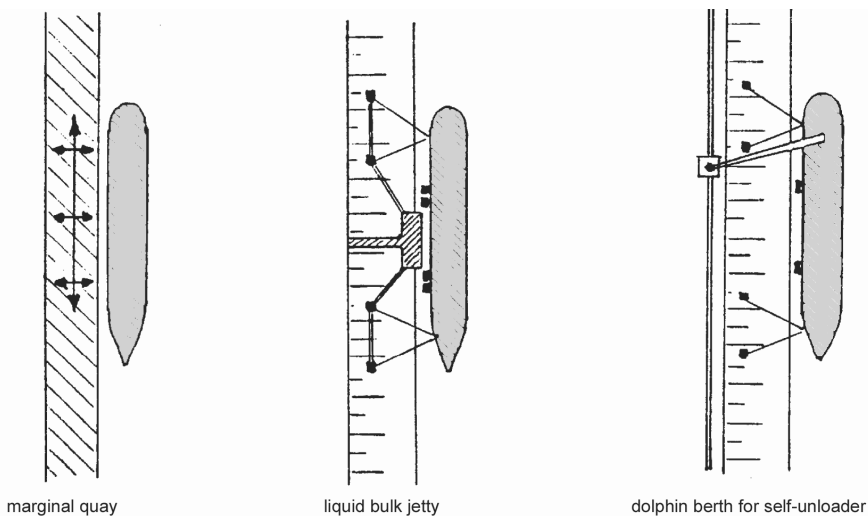

Figure 6.1 Different types of berths

The cheapest form of berth but not fully fitting in this overview is the *SPM (single point mooring)* used for the loading or unloading of oil and/or oil products in open sea. A submarine pipeline connects the SPM to the shore.

Liquid bulk carriers load or unload through pipelines. They, generally, have a central mid-ship manifold where pipelines from the different tanks connect with hoses or (un)loading

arms on shore. Such a process does not require shore-based equipment to travel alongside the ship. In consequence, a relatively simple and cheap platform suffices to carry the loading arms with often separate berthing or breasting dolphins and mooring dolphins to absorb the horizontal forces exerted by the ship.

But, also some dry bulk carriers are not very demanding with regard to berth and shore facilities. This applies to the so-called *self unloader* which carries its own unloading equipment. It consists of one or two longitudinal belt conveyors below the tapered holds, transferring to a vertical conveyor system which, in its turn, transfers the cargo to a horizontal conveyor carried by a swinging boom which can have a length of up to 70 m (see also Fig. 2.30). The boom conveyor discharges into a hopper and conveyor system on shore. Because of the length of the boom, the only berthing facilities that are required are breasting and mooring dolphins. (But, of course, the ship itself is more expensive per tonne capacity than a conventional bulk carrier.)

The *dry infrastructure* comprises such items as storage area pavements -an expensive item for container terminals-, roads, foundations for crane tracks, drainage systems, etc. The dry infrastructure usually does not constitute the most spectacular part of the terminal, but it is, nevertheless, a very necessary one.

The *suprastructure* consists of the sheds and other covered storage spaces as silos, offices, workshops, etc.

Terminal equipment, either fixed or mobile, is found in a tremendous variety. Fixed equipment comprises mainly belt conveyors and stationary cranes. Mobile equipment moves either on rails (all sorts of gantry cranes, stacker-reclaimers, travelling hoppers) or on, mostly, pneumatic rubber tyres (RTG's, FLT's, straddle carriers, tractors/trailers, a.s.o.). Equipment will be discussed more in detail in the chapters dedicated to a particular type of terminal.

The fourth and final terminal component mentioned is the *human resources*. It is certainly not the least important one. As in most industries, productivity, efficiency and quality largely depend on the capability and motivation of management and labour force. An old but well run and well maintained terminal will generally provide a better service level to its clients than a modern well-equipped terminal that is poorly operated.

6.4 Types of Terminals

There are as many types of terminals as there are ship types outlined in Chapter 2. Although the detailed aspects of planning and design are treated per type of terminal in the following chapters, a short overview is given here.

The main types of terminals that can be distinguished are

- Conventional general cargo terminals

- Multi-purpose terminals
- Ro-Ro terminals
- Container terminals
- Liquid bulk terminals, such as for:
 - Liquid gas
 - Crude oil
 - Oil products
 - Edible oil
 - Chemical products
- Dry bulk terminals, such as for:
 - Grain
 - Ore and coal
 - Special products (cement, sulphur, etc.)
- Fruit terminals
- Fish handling facilities
- IWT terminals
- Ferry terminals

(i) General Cargo Terminal

The conventional general cargo terminal is one of the oldest and, traditionally, was designed for the handling of break-bulk and later on also unitised general cargo. Since break-bulk and unitisation have given way, to a large extent, to containerisation, the (conventional) general cargo terminals have lost much of their importance in modern ports. Nevertheless, they are still needed. In fact new ones are still being built because the traditional layouts and dimensions no longer suffice. A modern general cargo terminal has to be able to handle a much greater variety of cargo, including containers carried on deck of multi-purpose vessels, at a much greater speed.

Of course, not all ports can permit themselves to build specialised terminals for all sorts of commodities. The investments required are mostly considerable and can only be justified if there is a certain minimum cargo flow through such a special terminal. Also, the space is sometimes lacking for the development of a variety of special terminals. Finally, specialised terminals can only live up to expectations -greater handling speed, lower price and less pilferage- if they are managed and staffed by personnel trained for and experienced in this particular sort of operation.

Therefore, the answer to the question whether or not to specialise is more than one of simple economics and arithmetic.

In developing countries, the rate of specialisation is lagging behind that of the industrialised world, not only for shortage of funds, but also because the training of management and labour is less advanced. This is understandable and not at all disastrous. On the contrary, it is unwise to enforce specialisation too rapidly.

In terms of cargo volumes handled, so apart from considerations of land availability and operational capability, a *special container terminal* cannot be expected to be economic at throughputs below approx. 50,000 TEU/year. A simple dry bulk terminal may become justified at a cargo flow of 0.5 to 2 million t/yr, depending also on the value

of the cargo. For oil and liquid gas, specialisation is normally required from the very beginning, not so much for economic reasons as well as for safety reasons.

(ii) Multi-purpose Terminal

The difference between a modern general cargo terminal and a multi-purpose terminal is very small. Very often the latter is developed from the former by some changes in the terminal lay-out and in the equipment used. Most multi-purpose terminals combine conventional breakbulk with container and/or Ro/Ro cargo and the essence is that the containers are not any more occasional, but part of the regular cargo flow for which specialised equipment is available. Converting an old general cargo terminal to a multi-purpose terminal is not so easy for a number of reasons:

- a) More space is often required and it has to be open. Hence the existing sheds and rails, which often run along the quays, have to be removed.
- b) The wheel loads of modern container cranes are greater and therefore the existing pavement is insufficient. If rail mounted cranes are used, the rails need foundations. Otherwise the stability of the quay front has to be checked and often to be strengthened.
- c) The ramps of Ro/Ro ships can not be placed on the quay, when bollards are spaced too closely. Bollards should be lowered (see Figure 6.2)

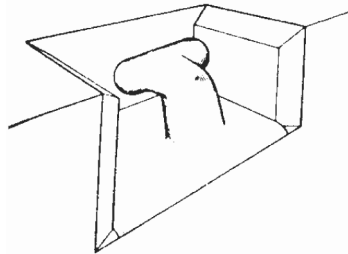

Figure 6.2 A lowered bollard

A typical example of a multi-purpose terminal is given in Figure 6.3.

(iii) Ro/Ro Terminal

As mentioned in Section 2.3.4 the type of ramp on the Ro/Ro ship determines the quay lay-out: in case of a single stern ramp special arrangements are needed, such as shown in Figure 2.15 and Figure 6.4. The pontoon on the right is often used in case the tidal variation in the port is too large for the ship ramp.

For ships with quarter and/or side ramps a marginal quay is suitable, provided that there are no obstacles like bollards and rails. Ro/Ro terminals show a great variety of landside lay-outs, depending on how much parking space is needed for the trailers. Often this is very limited: trucks arrive between 1 and 3 hrs before departure of the ship and continue their journey immediately after disembarkation in the other port. When there is no long term parking of trailers the surface area requirement is low and the terminal can be located where-ever this space is available (possibly even at some distance from the berth location). The lay-out shown in Figure 6.5 is the terminal of StenaLine in Hook of Holland.

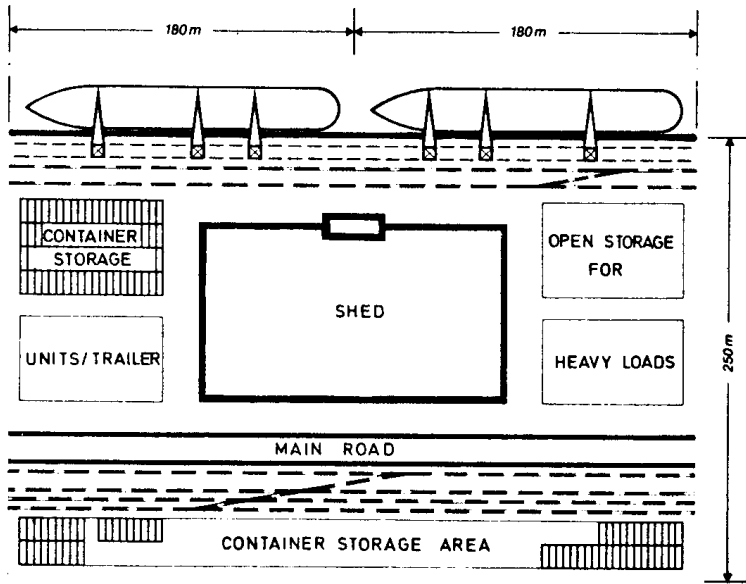

Figure 6.3 A multi-purpose terminal

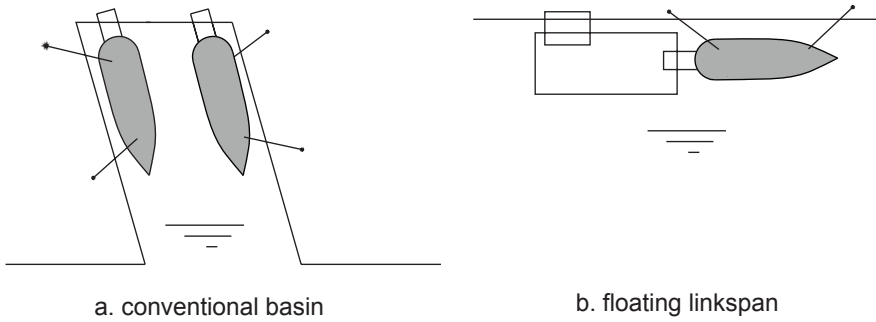

Figure 6.4 Ro/Ro berths for stern ramp

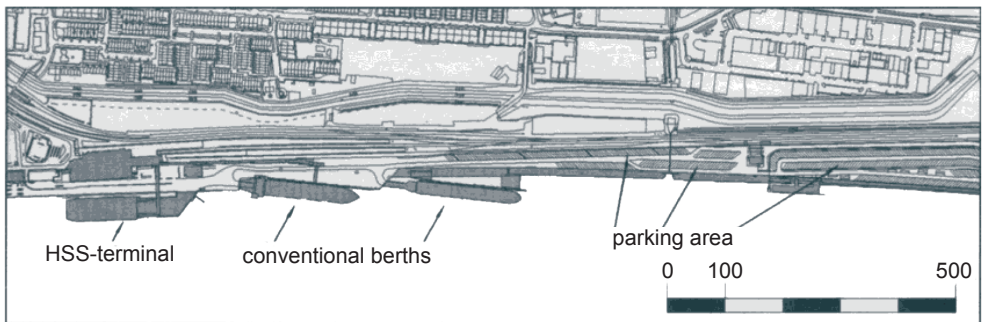

Figure 6.5 StenaLine terminal

(iv) Container Terminals

Contrary to Ro/Ro terminals the storage of containers on the container terminal often takes several days (NW-European ports) to several weeks (some ports in developing countries). This leads to substantial surface area requirements, notwithstanding the fact that containers can be stacked 3 high or more. Furthermore the storage of containers has to be as close as possible to the berths in order to achieve efficient (un)loading. Container terminals can therefore be easily recognised as large areas with the stacks either parallel with or normal to the waterfront (depending on the transportation systems). Another characteristic point of modern container terminals is the giant portainer cranes with their boom in upright position, when idle. See Figure 2.11.

(v) Liquid Bulk Terminals

Whether for oil, chemicals or liquid gas these terminals all have one thing in common: the ships are (un)loaded via a central manifold midships and there is no need for heavy cranes moving alongside. This implies that the shore-side facilities can be concentrated on a limited surface area, often a kind of platform on piles. And depending on the local geometry and hydraulic conditions the platform may be located nearshore or at some distance from the coastline, connected by a trestle or isolated as a so-called *island berth* (see Figure 6.6).

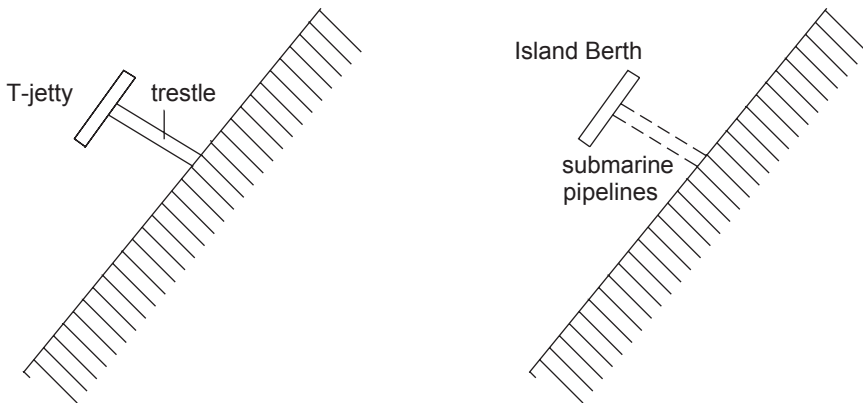

Figure 6.6 Different configurations of liquid bulk terminals

A special case is the terminal with offshore (un)loading facilities located in deep water. To make a clear distinction from the Island Berth one could limit this type of facilities to floating buoys and/or jacket structures to which the ships are moored by bow hawsers and connected by floating pipelines. In practice one finds the Island Berth also being referred to as an offshore facility. In the latter case the liquids are transported to/from the berth by means of submarine pipelines. The actual landside facilities comprise storage tanks, which may be located at quite some distance (e.g. close to the refinery or chemical factory in view of safety procedures).

(vi) Dry Bulk Terminals

Like the previous category, the dry bulk terminals are often designed and built for one specific type of cargo, be it iron ore, coal or grain. In view of the different transport processes needed for loading and unloading, there is in most cases a clear difference

between the export terminal and the import terminal for the same commodity . The loading of bulk carriers in the export terminal is done by conveyor belts extending right above the ship, from which the material falls freely into the holds at constant and high capacity. At the import terminal the same cargo is unloaded by means of cranes, which must be able to move around in order to retrieve all the material within the hold and to go from one hold to another. As a consequence the export terminal may be more similar to the jetty / platform arrangement for tankers, while the import terminal needs a quay for heavy cranes (apart from the self-unloader shown in Figure 2.30).

The storage part of the terminal is basically the same at both sides of water: the material is stacked in long piles in the open air or in closed silos, depending on the type of cargo. The piles are separated by the space for conveyor belts and the rails for the stacking / retrieving equipment (see Figure 6.7).



Figure 6.7 Dry bulk terminal of EECV in Europort, Rotterdam

(vii) Fruit Terminals

Modern fruit terminals are characterised by refrigerated warehouses, that are located near the waterfront. In some ports the cargo is transferred directly from the ship into the warehouse by means of conveyor belts. In most ports however there are luffing cranes at the quay, that can handle the different forms of packaging in which fruit is transported, palletised boxes or containerised. These cranes are much lighter than the ones on a container terminal or for dry-bulk handling, see Figure 6.8.



Figure 6.8 Fruit terminal

(viii) Fish Handling Facilities

As fishing ports may vary from a simple beach landing to a full fledged harbour, the facilities also show a large variation. The minimum requirement for a harbour is a refrigerated shed for storage of the catch. When the fleet and size of fishing vessels grows the harbour is usually equipped with a whole range of facilities, comprising quays, fish processing and marketing buildings, and areas for supply of the vessels, berthing while in port and ship repair. A typical example of a modern fisheries port is given in Figure 6.9.

(ix) Inland barge Terminals

Like the seaports the lay-out of barge terminals depends on the type of cargo handled. This may vary from multipurpose / containers to bulk cargo and the characteristics are similar to those of the seaport terminals. As mentioned in Chapter 3 the transport of containers by barge is rapidly increasing and with that the need for terminals. Stevedore ECT participates in a barge terminal along the Rhine at Duisburg, with special container cranes and stacking areas for different types of

containers. Similar terminals are found along the major rivers for the handling of relatively large numbers of boxes. Small scale terminals are gradually being established along the smaller rivers and canals, as demonstrated by the map of Figure 6.10.

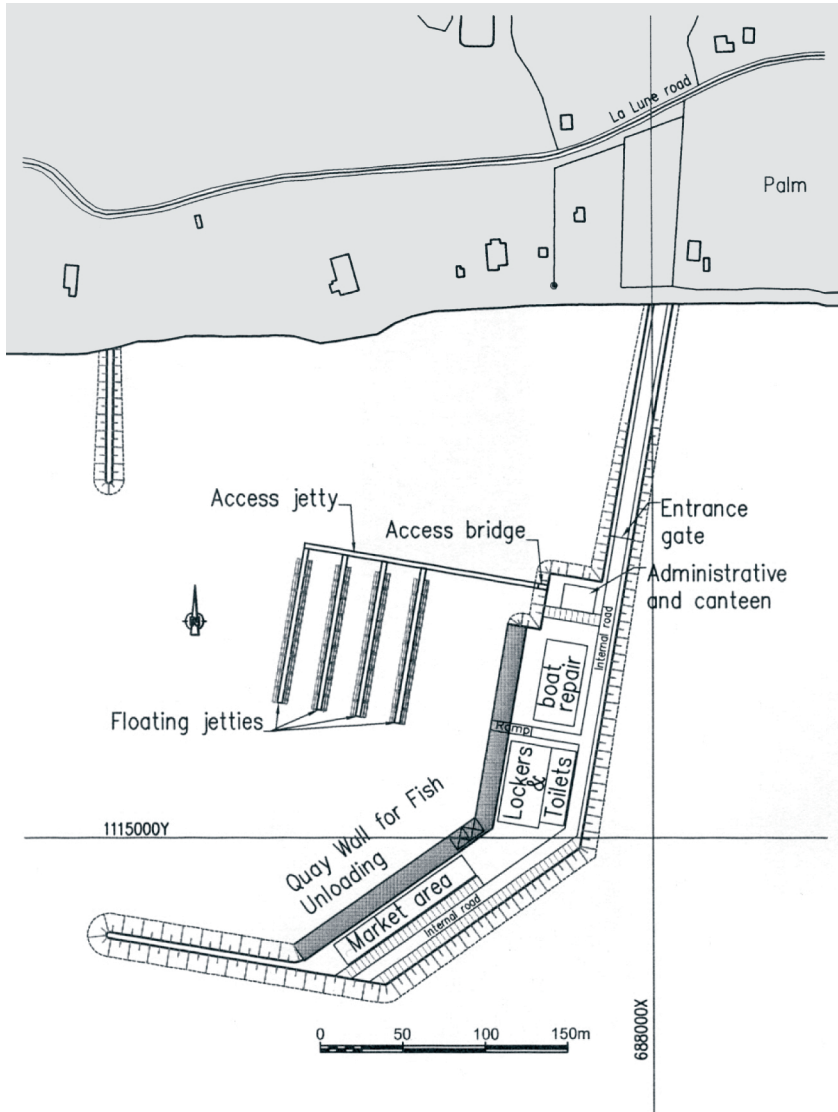

Figure 6.9 Lay-out of the fishing port of Esbjerg, Denmark
(Courtesy Royal HaskoningDHV)



Figure 6.10 Network of container terminals in The Netherlands

(x) (Passenger) Ferry and Cruise Terminals

While the Ro/Ro terminal is primarily built for cargo transport, the passenger ferry and cruise terminal is focused on the quick and safe movement of passengers. It will be clear that there is an overlap between the two, where both cargo and passengers are transported by the same ship. *Passenger ferries* and *cruise terminals* require a terminal building like a railway station, with ticket counters, waiting lounges, rest rooms, shops and restaurants. Between this building and the berthed vessel the passengers must be able to embark and disembark in a smooth and safe manner. For ferries this is normally achieved by bridges with sufficient capacity to minimise the time spent at the berth. In case of a cruise ship the time factor does not play an important role, but care is taken that passengers are transferred safely between the ship and the terminal building. An example is given in Figure 6.11, which is a typical homeport terminal, as can be seen from the large parking areas. Intermediate "ports of call" do not need these parking areas.

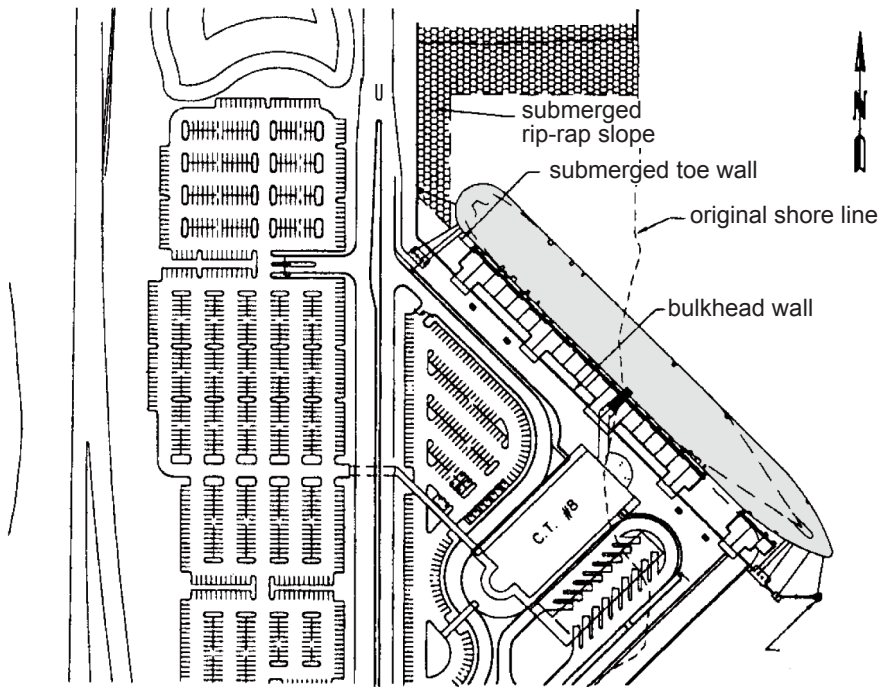

Figure 6.11 Cruise terminal lay-out, Florida, USA

6.5 Terminal Capacity: Maximum or Optimum

Terminal capacity can be defined in different ways, and without specifying which definition is used and which part of the terminal it is about, a discussion makes no sense.

To start with, capacity can refer to (un)loading, it can refer to storage or to through-transport. Here it will be assumed that through-transport poses no bottleneck and that terminal storage capacity is tuned to the (un)loading capacity, but also constitutes no restraint. Needless to say that, in practice, this is not always the case.

In terms of (un)loading capacity we can distinguish, in a general sense, the following:

- Maximum instantaneous capacity
- Maximum annual capacity
- Optimum annual capacity

The *maximum instantaneous capacity* can only be maintained for a short spell, e.g. when well rested crane drivers start unloading a still full dry bulk carrier. This sort of capacity is of no interest to the port planner, but it is of great interest to the equipment and system designer, because all equipment downstream must at least have the same peak capacity to avoid overload and clogging up.

The *maximum annual capacity* is the mean hourly capacity (averaged over a long period) $\cdot 24$ (hours/day) $\cdot 360$ (days/year). It is the capacity that can theoretically be attained if the

berths have a 100% occupation, and provided that there are no constraints on the land-side of the terminal. But, since ship arrivals and ship loading and unloading are time-wise stochastic processes, a 100% occupation leads to tremendous congestion on the sea-side of the terminal and to excessive ship waiting times, it is of no real interest to anybody. However, it is the way that many port authorities opt to define the capacity of their port, because it shows impressive figures.

The optimum annual capacity is the sort of capacity with which the port planner has to deal. Unfortunately, 'optimum', again, can be defined in different ways. If 'optimum' is meant to be 'economic optimum', it generally is that capacity or rather cargo throughput for which the overall port costs per tonne of cargo reach a minimum. The overall port costs comprise all fixed and variable terminal costs and all vessel-related costs during the service period as well as the waiting period, including all port dues. In practice it is often impossible to determine the optimum capacity in this way, because port and terminal costs on one hand, and ship related costs on the other hand are born by different parties, each of which is only interested in its own economic optimum.

In case of integrated, centrally managed transport chains (which applies to some liquid and dry bulk trades), the true economic optimum can be sought, which is attained when the total transport cost per tonne from source or supplier to consignee or consumer has reached a minimum. Port costs may then be well above an absolute minimum, e.g. because a deeper and more expensive channel and quay allow the use of bigger ships, which reduces maritime transport costs. In other words, optimum terminal capacity in those circumstances, refers to a given size of ship, which size results from an earlier and more general optimisation exercise.

However, 'optimum' does not necessarily refer to an economic optimum, i.e. there are other optimisation criteria imaginable and also used in practice. For instance, container terminals that have to operate in a heavily competitive regional market may wish to guarantee a certain minimum service level in order to attract shipping companies. Such a service level could be described, for example, by a guarantee that no more than $x\%$ of the vessels visiting the terminal, will have a waiting time in excess of y hours and/or that no more than $m\%$ of the vessels will have a total port time in excess of n hours.

The tools used in quantifying these optima, whether referring to cost minima or to service level, are, for relatively simple situations, the analytical queuing theory, or, for more complex conditions, discrete simulation models. They yield for specific boundary conditions the ship waiting times, which can be incorporated if so desired into the cost minimisation study.

6.6 Terminal Dimensions

The two main components of any terminal are the number of berths, which determine the length of quay or waterfront required, and the storage area. To calculate these from a design

annual throughput/storage capacity basically three methods are available, with increasing level of detail and accuracy:

- i. An estimate using capacity factors. Empirical values of tonne cargo per m quay length, respective per m² storage area.
- ii. A calculation of the berth productivity/storage capacity taking into account the specific type of handling equipment and their numbers, but estimated occupancy values.
- iii. A detailed calculation as per (ii), but also accounting for variations in arrival- and service times of vessels and applying queuing theory or simulation models to determine the proper quay length and storage area.

The latter method is used in the final stages of master planning and in the design phase and is dealt with in Groenveld, 2001 (see ref. in Section 5.7). Methods (i) and (ii) are used in the preliminary development of lay-outs and are presented below and in the following chapters. The m² refers to the total terminal area, including internal roads, offices, workshops and the like.

6.6.1 Quays and Jetties

Capacity factors for quays and jetties are given as follows:

conventional general cargo	500 to 1,000	t/yr per m
containers (Drewry, 2010)	500 to 1,500	TEU/yr per m
	5000 to 15,000	t/yr per m
coal (Van Vianen et al, 2014)	10,000 to 30,000	t/yr per m
iron ore (ditto)	25,000 to 75,000	t/yr per m
crude oil	70 million ¹	t/yr per berth

The values for coal and iron ore refer to import terminals. For export terminals these factors will be twice as high.

The wide ranges reflect the large variation in cargo handling productivity, depending on the type of equipment (e.g. cranes, vehicles), number of ships, etc. A first estimate based on these capacity ratios very limited accuracy and shall be improved soonest by the approach according to method (ii).

The productivity of a berth or jetty is given in general terms (independent of type of cargo):

$$c_b = P \cdot N \cdot n_{hy} \cdot m_b \quad (6.1)$$

P	=	(un)loading productivity per handling entity (crane, gang, pumps) in t/hr.
N	=	number of handling entities on a ship of average size.
n_{hy}	=	number of operational hours per year (depending on number of shifts).
m_b	=	estimated berth occupancy factor.

¹This high capacity is related to terminals receiving only VLCC and ULCC tankers. But also for smaller vessels the tanker berths have a relatively high capacity leading generally to low occupancy rates.

The value of m_b depends on the type of terminal and the number of berths and will be treated in the subsequent chapters for different terminals. In general a random arrival and a low acceptable waiting time of ships lead to a low value of m_b , while a strict schedule of arrivals (e.g. ferries) makes it possible to choose an m_b close to unity.

By dividing the design annual throughput by the berth productivity the number of berths of jetties is found. The quay length L_q is then calculated by multiplying this number with the length of the average ship (or the design ship in case of a single berth), adding the necessary space between ships for mooring and/or safety (in Equation 6.2 taken at 15 m, but in case of larger ships going up to as much as 30 m).

$$L_q = \begin{cases} L_{s,\max} + 2 \cdot 15 & \text{for } n = 1 \\ 1.1 \cdot n \cdot (\bar{L}_s + 15) + 15 & \text{for } n > 1 \end{cases} \quad (6.2)$$

In case of jetties the waterfront area depends on the configuration of the jetties as discussed in Chapter 10.

6.6.2 Terminal Areas

For gross storage area, including rail tracks and service roads within the storage area, the following capacity factors serve:

conventional general cargo	4 - 6	t/yr per m ²
containers (Drewry, 2019)	0.75 - 5.5	TEU/yr per m ²
coal (Van Vianen et al, 2014)	15 - 75	t/yr per m ²
iron ore (ditto)	30 - 80	t/yr per m ²
crude oil	40 - 50	t/yr per m ²

The above figures for coal and iron ore refer again to import terminals. For export terminals, where the utilisation of the stock piles is often directly linked to the loading of the vessels, the factors are 2-3 higher.

For planning purpose not only the gross storage area needs to be determined, but the overall surface area of the terminal, including space for other internal roads, (office) buildings and waterside area. An interesting study by Kox (2017) presents the “total terminal factor” as the ratio of gross storage area and total terminal area. For containers and liquid bulk and average value of 0.6 is found and for dry bulk 0.7. As to be expected quite a large variation is found between different terminals in the world, but for the initial planning these average factors are useful.

As an alternative for the capacity factors the following (generalized) equation can be applied:

$$A_{gr} = \frac{C \cdot \bar{t}_d \cdot f_{area}}{\bar{\rho}_{cargo} \cdot h_s \cdot 365 \cdot m_s} \quad (6.3)$$

A	=	gross storage area	[m ²]
C^{gr}	=	design annual throughput	[t/yr]
\bar{t}_d	=	average dwell time of cargo	[days]
f_{area}	=	factor accounting for difference between gross and net area and cargo specific requirements	[-]
ρ_{cargo}	=	average cargo density	[t/m ³]
h_s	=	average stacking height	[m]
m_s	=	estimated storage occupancy	[-]

Note that the gross storage area in this equation only includes the space needed for roads, pipelines, crane rails or conveyor belts within the storage and not for other internal roads, offices etc.

The *dwell time* depends on the type of cargo and the specific conditions of the terminal (high through-flow of strategic reserves). The value of m_s depends on the variations of the oncoming and outgoing flows, but also on contingency options, like the availability of additional storage space at some distance from the terminal (extra costs, but possibly cheaper than having overcapacity during most of the time).

6.7 References

- Drewry, Global container terminal operators, 2010. Annual review and forecast. 2010
- Kox, S.A.J., A tool for estimating marine terminal dimensions and costs in a projects feasibility phase. MSc. Thesis, Delft University of Technology, 2017
- Van Vianen, T., Ottjes, J. and Lodewijks, G., Dry bulk terminal characteristics. Proc. of Bulk Solids Handling, Mumbai, 2011

Chapter 7

Container Terminals

Co-authored by Peter Quist and Bas Wijdeven

7.1 Introduction

In Chapter 2 Maritime Transport the development of containerized transport has been addressed.

The logistic process of container terminals is often determined by the future user, the stevedoring company or the shipping line, which operates its own terminals. They have their preferred terminal concept, based on past experience and in-house technical know-how. The port planner must integrate the requirements following from this logistic process with the spatial conditions of a specific location.

At the time of master planning the future terminal operator is sometimes not yet known. In this case the port planner will apply the general principles as outlined in this chapter and will have to create sufficient flexibility in the layout to be able to accommodate future user requirements.

7.1.1 Historical development of container transport

After World War II world trade increased rapidly and with it sea transport, leading to serious congestion in ports and long waiting times. Most of the goods were shipped in the form of general cargo, which was time consuming and labour intensive, also refer to Fig. 7.1.

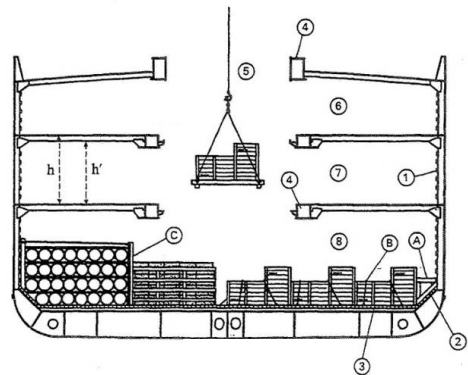

Figure 7.1: Loading and unloading of a general cargo vessel

The container had been introduced in the fifties as a standard size box for transport of cargo by truck and rail across the USA. Its use in sea transport seemed a logical step in view of the abovementioned problems, but received initially severe resistance, in particular by the powerful unions of dockworkers. It did reduce turnaround and waiting time in ports substantially.

In 1955 the White Pass & Yukon Route started operating a fully inter-modal service between the Canadian mainland (Vancouver) and Alaska (Skagway). For this purpose the specially built container vessel Clifford J. Rogers was deployed (Fig. 7.2). The vessel had a capacity of 4000 tons or 600 containers. After arriving in Skagway, the containers were transported overland by truck and rail, see Fig. 7.3.



Figure 7.2 M.V. Clifford J. Rogers, the first ship specially designed as container vessel

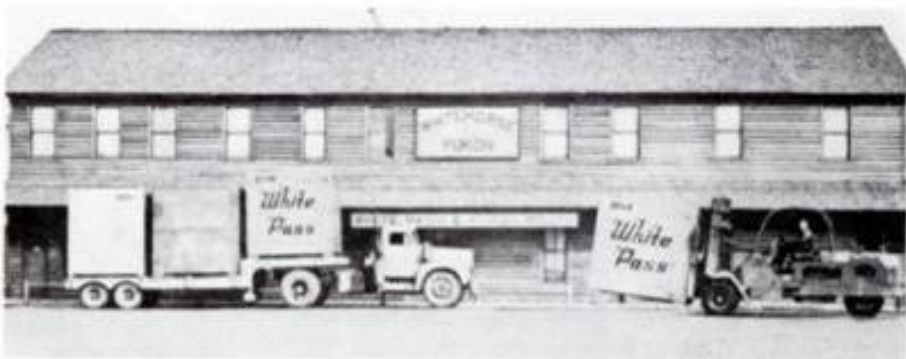

Figure 7.3 Containers loaded by fork-lifts to specially designed low-bed trailers as early as 1953

This example of early use of containers is limited to a particular line. The container was not yet standardized, which prevented spreading of the concept.

7 Container Terminals

Malcolm McLean is generally regarded as the godfather of containerization. His initiatives led more or less to the global containerization as we know today. His trucking company grew out into one of the largest truck companies in the US. From 1950 onwards, he used containers to reduce the loading and unloading time for his trucks. He sold his business in 1955 in order to buy a shipping line (known as Sealand, later taken over by Maersk) and to apply the container concept to maritime transport, using former World War II tankers converted to container vessels. In the sixties, McLean's engineers developed technology to further speed up container handling, such as the corner casting, the twist lock, the spreader and the first container gantry crane. During this decade also the parties involved in container shipping finally agreed on a standard for the ISO container.



Figure 7.4: Arrival of the first Sealand container in the Port of Rotterdam in 1966

Following Sealand's success, many other shipping companies entered the container business. At the end of the sixties, Sealand operated 36 container vessels and 27,000 containers and offered services to 30 ports worldwide. Initially limited to coastal shipping along the US West and East Coast, the first Sealand containers arrived in Rotterdam in 1966, see Fig. 7.4. Over the past 45 years container shipping has spread across the globe, taking over a major share of the general cargo trade.

The smallest early ISO container had dimensions of 8 ft · 8 ft · 20 ft (2.44 · 2.44 · 6.10 m³). Because of this dimension the capacity of a vessel or a container storage yard is still expressed in Twenty Feet Equivalent Units or TEU. Nowadays forty feet long containers

are used besides the twenty feet containers, and additional standard sizes for length, width and height have been introduced.

The increased productivity compared to conventional break bulk transport is partly due to the fact that many pieces of cargo are packed into one container, which can be handled in one lift, and partly due to the use of the twist lock during handling and transportation, see Fig. 7.5. The twist locks, which are mounted on the spreader, are inserted into the four upper corner castings of the container and fastened automatically in a matter of seconds.

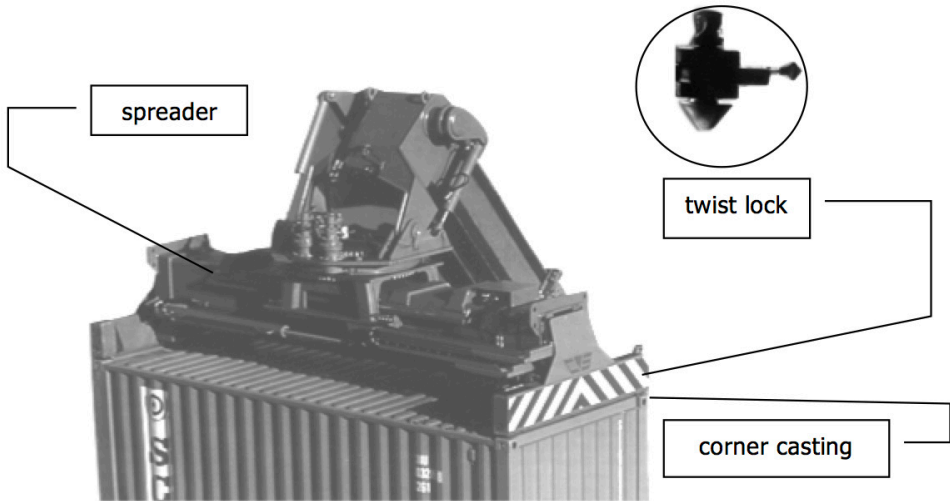

Figure 7.5: Twist lock and corner casting

On a truck the lower four corner castings are also fastened by twist locks as shown in Fig. 7.6. On a rail wagon containers are not fixed by twist locks. The lower corner castings fall over a cone, so the container can not slide off sideways.

7 Container Terminals

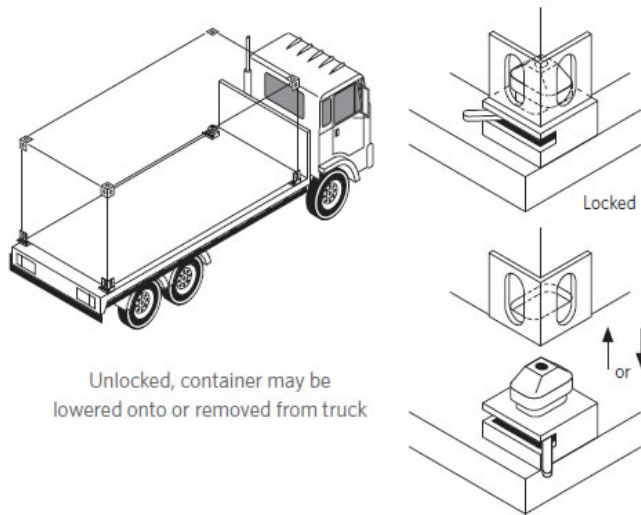

Figure 7.6: Typical twist lock on truck (source: website NZ transport agency, www.nzta.govt.nz)

Transport has never been cheaper than today. However, the worldwide shift to containerisation of almost all cargo once shipped as general cargo, required enormous investments. These investments were only made because of the great advantages of containerisation (Van Beemen, 2008):

- Labour saving: Up to 30 tons of containerized cargo can be discharged or loaded in a minute, by a crew of two to three people. Thanks to containerisation, labour intensive and costly transfer of boxes, crates, drums, bags, sacks and bales from one mode of transport to another has become something of the past;
- Economies of scale: For general cargo, larger vessels and larger port facilities were no solution, as loading and discharge time were already disproportionately high compared to actual sailing time and cost. Containerisation brought those technical solutions and standardisation together with the increase in scale of operations and reduction of cost;
- Time saving: With containerisation, unloading and loading times of vessels, trains and trucks were reduced considerably. A large container vessel spends 24 hours in port against several days for a much smaller conventional cargo vessel;
- More transport options: World-wide container transport infrastructure offers shippers the opportunity of long and complex transport chains, which are fast, reliable and economic;
- Security and damage reduction: Because a container is packed only once, more attention can be given to packing it properly, with knowledge of the product;
- Safety: General cargo stevedoring was hard, dirty and dangerous work. Although container handling is generally a safer activity than general cargo stevedoring, accidents still happen;
- Cost saving: All of the above leads to an enormous cost saving, which continues with the ongoing scale increase in container transport. Fig. 7.7 shows the reduction of cost per TEU with increasing vessel size.

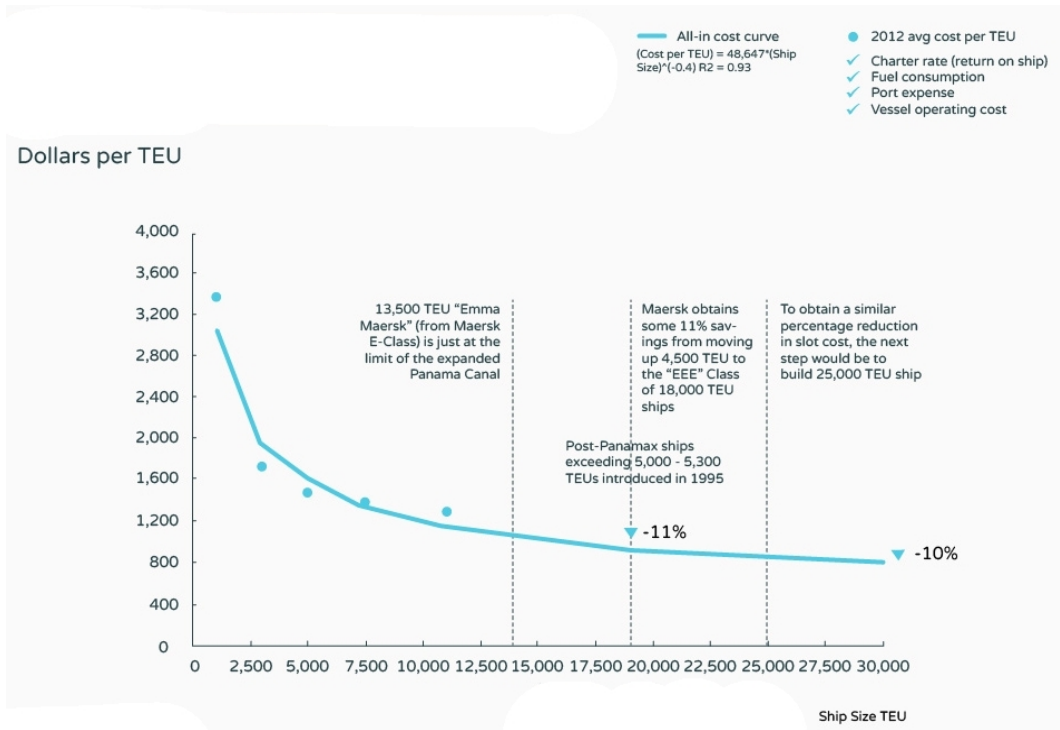

Figure 7.7: Development of all-in container transport costs (source: HKND, Drewry)

7.1.3 Disadvantages of containerisation

There are some disadvantages too (Van Beemen, 2008):

- **High investment cost:** Well-equipped container infrastructure requires high investment. For the poorest nations in the world it is difficult to raise the required capital for governmental owned container terminals. That way those countries do not get access to low-cost and efficient transport of export products. This slows economic development and transport volumes develop insufficiently to justify investment in good container terminals and hinterland connections. Fortunately, in the last decade the large global terminal operators have invested more and more in terminal facilities in developing countries;
- **Empties:** For an unpacked import container it is not always possible to find export cargo nearby. The empty container must then be transported to a location where export cargo is available. This location may be as far as the other end of the world. This effort costs money and generates no direct income. Efficient repositioning of empties makes the difference between a loss or a profit. About 20% of the total global port moves are empties. Because the dwell time for empties is higher than for loaded containers, the percentage of empties stored on terminals is often considerably higher. There is a lot of idle capital tied up in empty containers and there is also the cost of storing empties on expensive land close to the quay side;
- **Labour:** Because of containerisation the large general cargo stevedoring companies in

7 Container Terminals

the developed world have all gone. As a result their huge workforce became unemployed and only a part of the general cargo workers could be absorbed by the new container terminals. In some developing countries this process is still ongoing;

- Theft: Theft in ports was widespread in the past. However, the scale of individual cases was mostly limited. Because of containerisation, theft in ports now concerns entire containers and is the field of organised crime;
- Security: Customs have deployed high tech solutions such as X-ray scanning. However, experts are concerned that international terrorism may use container infrastructure for terror attacks.

7.1.4 Major transport routes

The increasing importance of containerization reflects changes in the global structure of manufacturing and production. Mainly due to the move of low-cost production to South-East Asia, India, Central America and Eastern Europe, a greater share of the world's production is now entering the world trade. The consequence of this move is a substantial growth in activities for the shipping lines in terms of geographical coverage, frequency of services and transit times. Despite globalization and the growing demand for maritime trade, it appeared very difficult to keep stable freight rates in a highly competitive environment. In order to minimize the cost per container slot, the global ocean carriers had to adopt the economy of scale approach, both in vessel size and organizational structure, which enabled sharing of investment costs and reduction in the operating cost per container slot. They service round-the-world routes, calling at a series of terminals and thus ensuring efficient use of their capacity.

The two major routes are the Europe – Far East route and the Trans Pacific – North route as shown in Fig. 7.8.

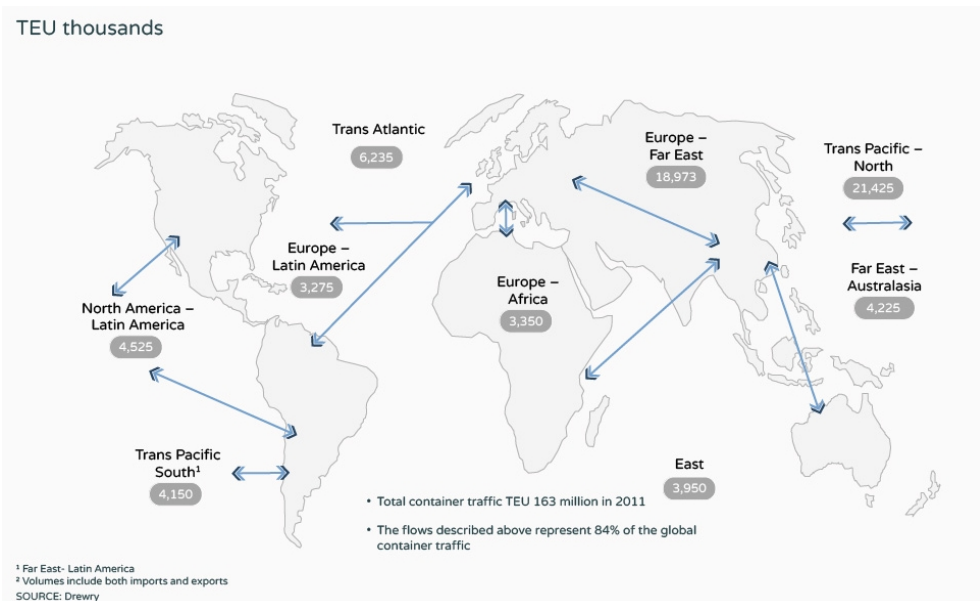

Figure 7.8: Major global container traffic flows, 2011 (source: Drewry)

As an example, a detailed west- and eastbound schedule for Asia – Northern Europe is presented in Fig. 7.9. The transit time from Shanghai to Rotterdam is 33 days.



Figure 7.9: Schedule Mediterranean-Asia (source: CMA-GCM)

An example of a Transpacific-North route between China and the US-west coast is given in Fig. 7.10. The transit time from Shanghai to Long Beach is 14 days. CMA CGM maintains a weekly service on this route, deploying six container vessels.



Figure 7.10: Schedule China - US west coast (source: CMA-CGM)

The transit time between Shanghai and New York through the Panama Canal is 28 days, see Fig. 7.11.

7 Container Terminals



Figure 7.11: Schedule China - US east coast (source: CMA-CGM)

7.1.5 Global container throughput

Figure 7.12 shows the forecasted medium-term global container throughput including empties and transshipment. The world container traffic reached a volume of 616 million TEU in 2013 and the forecasted growth rate is around 6% per annum. The growth of vessel size and TEU capacity poses new challenges on ports and terminal operators to keep the service time of these vessels within 24 hours. Various approaches are followed to solve this problem: increase of crane productivity, introduction of automation and handling of the vessel on both sides.

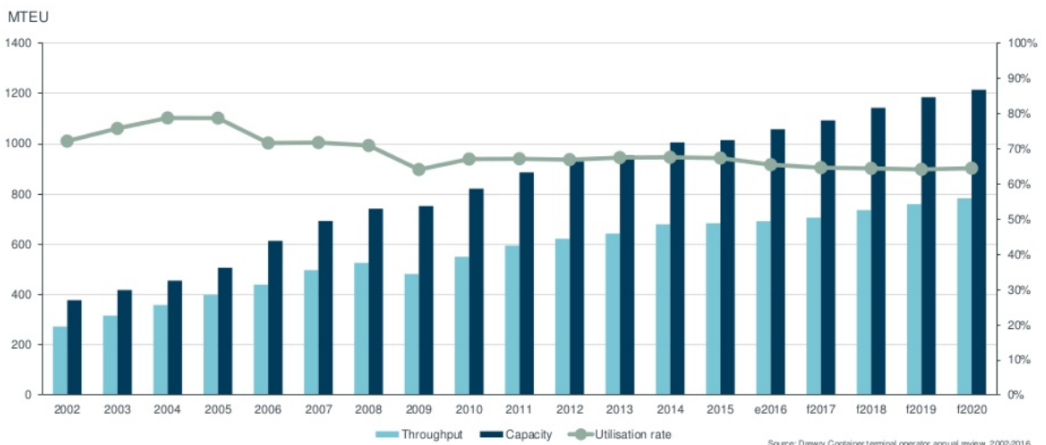

Figure 7.12: Global container throughput and capacity development (source: Drewry Maritime Research container terminal annual review 2002-2016)

7.2 Container types and container vessels

7.2.1 Container types and sizes

Containers continue to replace traditional general cargo and break bulk stowed in vessel holds. Containerisation of cargoes is becoming ever more widespread worldwide and almost all products, including some materials previously handled in bulk, are now transported by container.

The International Standards Organisation (ISO) issued the official standard dimensions of containers:

- The most common standard is the TEU (Twenty feet Equivalent Unit), which is a container with $L = 20$ ft (6.10 m), $B=8$ ft (2.44 m) and $H=8$ ft 6 inches (2.60 m). Its own weight is about 24 kN. Its internal volume is approximately 32 m³ and the maximum “payload” amounts to 220 kN, up to 280 kN for High Cube ($H= 9$ ft 6 inches/ 2.90 m). This implies that the container cannot be filled to the limit with high density cargo. In practice the payload is much lower even, with an average value around 100 kN;
- The forty feet container (2 TEU or 1 FEU) measures twice as long and has the same width and height as the 20 ft container. Its own weight is about 45 kN and the internal volume measures 65 m³. The maximum payload is only marginally higher than the TEU: 270 kN, but the average payload in practice is only 175 kN.

See Fig. 7.13 for typical dimensions of containers. There are several container types in use, including:

- Oversize containers (longer than 40 ft) (of which in particular the 45 ft is used more often);
- High Cube containers (height 9 ft 6 inches, 2.90 m);
- Over width containers (wider than 8 ft). (Pallet wide containers, often 45 ft in length).

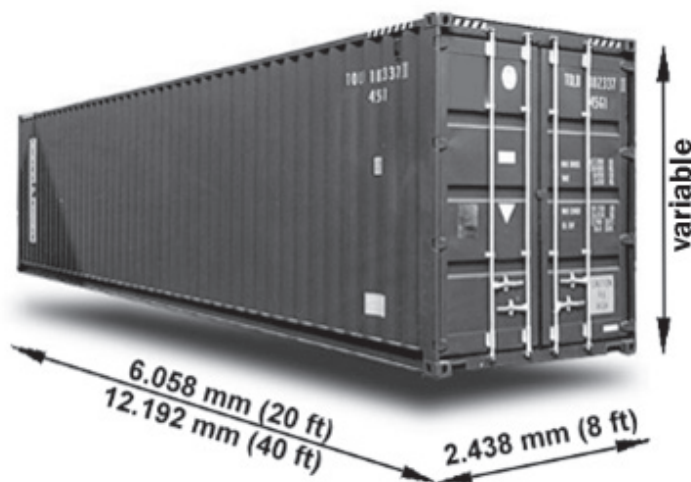

Figure 7.13: ISO typical container dimensions

7 Container Terminals

The latter category originally measured 8 ft 2.5 inches (2.50 m), because that width allowed placing two Euro pallets side-by-side inside the container. Moreover, it was the maximum width permitted on the West European roads. Since this was relaxed to 2.60 m, the container width of 8 ft 6 inches has become more common.



The existence of non-ISO containers has several negative consequences, as can be expected:

- On the vessel the cell guides in the holds are designed to receive ISO containers. Hence Oversize and Overwidth containers have to be placed on deck. This is limiting the flexibility of the loading schedules;
- On the terminal the Oversize containers, also known as OOG (Out Of Gauge) need their own stacks, which again limits the flexibility;
- The “spreader”, the frame used under the crane trolley or by the yard equipment to pick up a container by means of the four twist locks at the corners, must be adjustable to accommodate the different lengths (20, 30, 40 or 45 ft);
- For the onward transport of containers by road or rail different lengths require special provisions on the trailer or rail wagon to fasten the containers at the corner castings.

The information below has been derived from PIANC (2014) and has been updated at some points.

Apart from the variation in size there is a range of special purpose containers, see Table 7.1.

Table 7.1: Container types

Container type	description
Standard container	20 ft, 30 ft, 40 ft and their High-Cube Versions Standard container with full steel box top, bottom and sides and end doors. Also referred to as dry cargo container or dry van.
 Standard container	
Hardtop-Container	20 ft, 40 ft and 40 ft High-Cube Version Standard container with a removable steel roof. Used for heavy or tall cargoes - with loading from the top or side.
 Hardtop-Container	
Ventilated-Container	20 ft Especially for cargo which needs to be ventilated.
 Ventilated-Container	

Ports and Terminals

Refrigerated-Container



20 ft, 30 ft, 40 ft, 45 ft and their High-Cube and pallet wide versions

The cooling is provided via a built-in electrically driven unit. Power is supplied either through power grids on board or ashore, or by “clip-on” diesel generators during land transport.

Open-Top-Container



20 ft and 40 ft

Provided with removable tarpaulin. Especially for over-height cargo. Loading from the top or side.

Flatrack



20 ft, 40 ft and 40 ft High-Cube Version

Flats, in fact just a bottom structure with corner castings used for large pieces of cargo, which can not be placed inside a box (but comply with the size and payload requirements).

Platform



20 ft and 40 ft

Especially for heavy loads and oversized cargo.

Tank Container



most common length is 20 ft, also other lengths exist, open frames of (mostly) TEU size around a tank. In case of hazardous contents these containers need a separate location from the rest in the storage yard with adequate safety measures.

For the transport of liquids including foodstuffs, for example:

- Petrochemical products
- Alcohol
- Fruit juices
- Edible oils
- Food additives

Dry ISO containers are used for general purpose transportation. The cargo is loaded via doors at the end of the container. They are totally enclosed, box type containers. These containers are also called dry vans.

Thermal or insulated ISO containers are used to transport chilled and frozen goods. They are also used for temperature sensitive products. These containers have insulated walls but they don't have a refrigeration unit.

7 Container Terminals

Refrigerated ISO containers (reefers) are used when a steady temperature must be maintained during transportation. They are the same as insulated containers but have a built in refrigeration unit. Refrigerated containers or reefers require electrical supply points both on the vessel and on the terminal. In case reefers are stacked in multiple layers, reefer racks are provided.



*Figure 7.14: Reefer racks in container storage
(source: TPS Valparaiso, <http://portal.tps.cl/>)*

Flat racks and platforms are used to transport heavy machinery. They have no side walls, but may have end bulkheads. There are also collapsible flat rack containers. They are open sided containers with end bulkheads that can be folded down when the rack is empty.

Open top containers are used to transport heavy, tall or hard to load cargo, and bulk material, such as coal or grain. They are box type containers with no top. They can be loaded from the top or end of the container.

Tank type containers are used to transport liquid or bulk materials. They are manufactured with a cylindrical tank mounted within a rectangular steel framework. They have the same overall dimensions as other intermodal containers. Heated tank containers for e.g. wax.

7.2.2 Container vessels

The “first generation” container vessels were general cargo vessels, converted to carry containers. Since then several classes of container vessels have been built with increasing dimensions and capacities (see Table 7.2). For port planning purposes the development of the size of container vessels is of great importance. Parties involved continuously try to beat competitors by creating the possibility to accommodate vessels bigger than existing ones. Limiting factors in vessel design, such as structural strength, engine capacity, cavitation of propeller and rudder, cargo handling speed and available depth in ports were gradually resolved. The recently built container vessels enabled economies of vessel size due to their

large hauling capacity, but diseconomies of scale in their handling capacity (relative long service times in ports). To maximize scale effects it is therefore reasonable to deploy big vessels on long distance routes (Veldman, 2011).

Table 7.2: Container vessel characteristics

	TEU capacity	DWT (range)	L_s (m)	D (m)	B_s (m)
1st generation	750-1100	14,000	180-200	9	27
Feeders	1500-1800	30,000-35,000	225-240	11.5	30
Panamax I	2400-3000	45,000-80,000	275-300	12.5	32
Panamax II	3000-5000	80,000-100,000	290-310	12.5	32.3
Post Panamax	5000-10000	90,000-120,000	270-320	12.5-16	38-42
New Panamax	6000-9000	90,000	310-350	14	43
	10,000-14,500	120,000-150,000	366	15.2	49
Post New Panamax	14,500-18,000	157,000-194,000	400	15.2-16	56-59

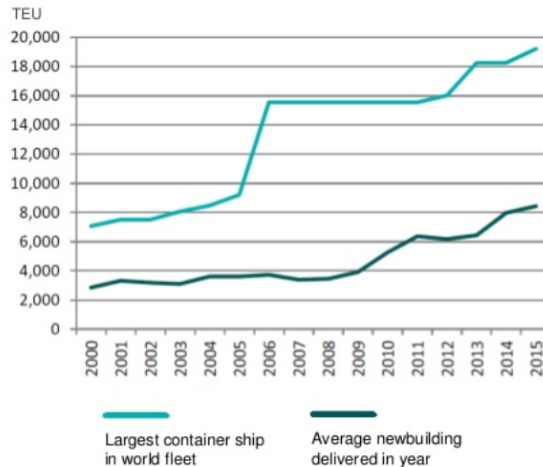

Figure 7.15: Development of container vessel capacities (source: Drewry, November 2015)

Some examples of berthed Post New Panamax vessels are shown in Fig. 7.16 and 7.17. To give an idea of characteristics and dimensions of the largest container carriers, the mid-ship section and profile of the 18,000 TEU Maersk Mc-Kinney Møller are given in Fig. 7.18 and 7.19.

7 Container Terminals



Figure 7.16: Berthing of the CSCL Star at the Port of Felixstowe
(source: porttechnology.org)



Figure 7.17: Majestic Maersk at the Port of Felixstowe
(source: Dream Designs Colchester)

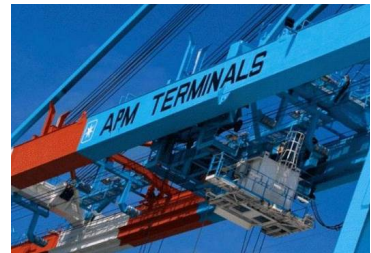

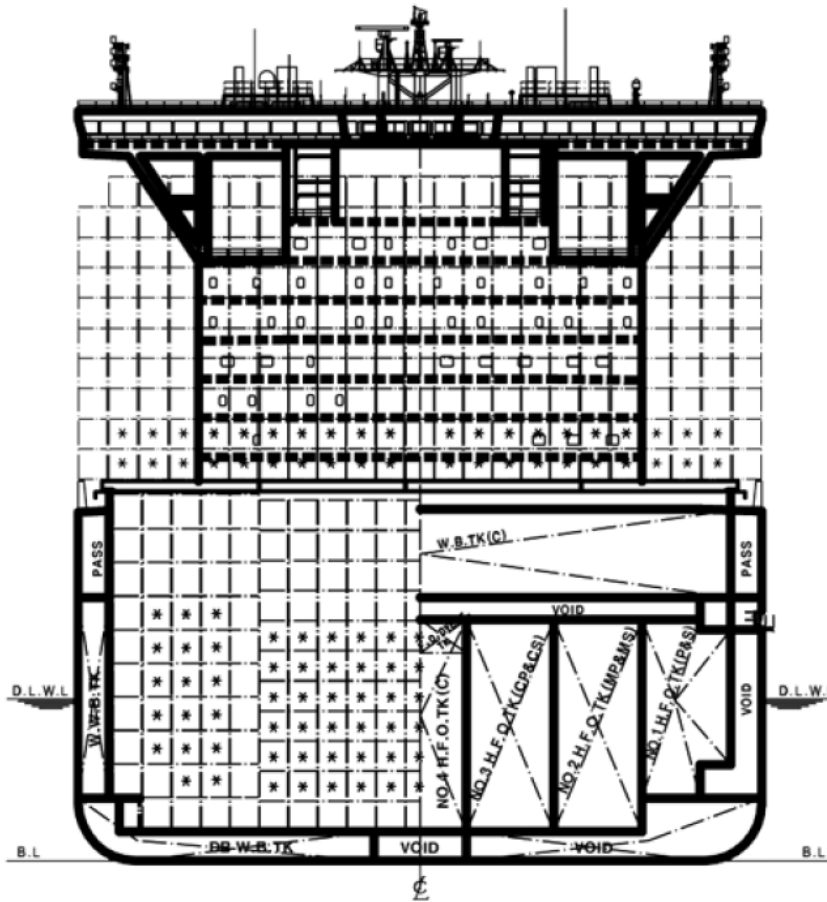

Figure 7.18: Mid-ship section of 18,000 TEU Maersk McKinney Møller (Royal Inst. Of Naval Arch., 2013)

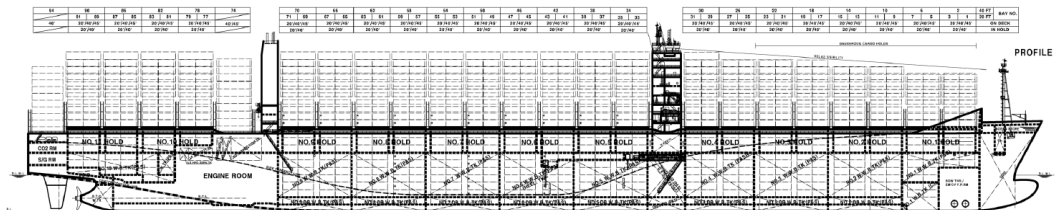

Figure 7.19: Profile of 18,000 TEU Maersk McKinney Møller (Royal Inst. Of Naval Arch., 2013)

The Maersk Mc-Kinney Møller has the following main characteristics (Veldman, 2011):

- The moulded depth from keel to upper deck is some 30 m;
- 11 cargo holds, each hold has 22 hatches;
- Deck containers are placed in 23 rows, in tiers of 6,7,8,9 or 10;
- Crew: 14;

- Deck capacity 10,644 TEU;
- Hold capacity: 7,696 TEU;
- Total capacity: 18,340 TEU;
- Propulsion: engine output of 29.680 kW, two propellers with diameter 9.65 m.

7.2.3 Global ocean carriers

The main producers of transport services are the global ocean carriers: the shipping companies. Ocean carriers organized themselves in alliances. Ocean carriers cooperate to move freight. Carrier alliances are vessel-sharing agreements: all carriers within an alliance pool together their fleets of ships, moving containers on one another's behalf to extend their service offerings and geographic coverage.

The main alliances represent about 77% of global container capacity and about 96% of all East-West trades' container capacity. These are at present:

- 2M Alliance: Maersk, MSC
- THE Alliance: NYK, MOL, K Line, Yang Ming, Hapag-Lloyd (with UASC)
- Ocean Alliance: CMA CGM, Evergreen, OOCL, COSCO Shipping

7.2.4 Terminal operators

This section elaborates on the major terminal operators in the container industry and the way terminal operation has developed in the past. The section has been derived from Midoro et al.(2006).

During the 1990's there was acceleration in worldwide private investment in container terminals. As a result of this process the share of state-owned container terminal facilities has greatly decreased during the last two decades.

International private terminal operators can be classified as follows:

- Pure stevedoring companies which are essentially focussed on port container handling;
- Global ocean carriers deciding to integrate their liner activities by managing container handling facilities.

During the 1980's, stevedoring companies started to globalize their business, exploiting the opportunity of port privatization in other continents, diversifying their business. The 1980's were also characterized by another development: the world-wide spread of intermodal transport, combining sea and rail transport. At that time some ocean carriers decided to integrate their activities by managing container port facilities by creating intermodal companies, providing door-to-door services and to improve control and increase in revenue of freight.

This was followed by the birth and explosion of globalization in the 1990's, this induced a further increase in vessel and terminal size. Thanks to the expansion of port's hinterlands, shipping lines could rationalize their schedules by reducing the number of ports of call.

Due to the limited number of terminals able to operate the mega-size vessels, and the difficulties that rise from receiving these mega vessels in the traditional multi-user terminals, the handling cost per shipped container increased. For this reason ocean carriers like Maersk, MSC, CMA CGM and COSCO decided to run self-owned, reliable and efficient terminal facilities all over the world. These 4 largest international container shipping companies (largest Maersk, followed by MSC, CMA CGM and COSCO) all have their own terminals. Maersk has APM Terminals, MSC has Terminal Investment Ltd, CMA CGM has two port operators: Terminal Link and CMA Terminals and Cosco has Cosco Shipping Ports.

So in most cases global ocean carriers run their own terminal with a captive market and with residual capacity to service the other partners in global alliances and other operators. Unlike pure stevedoring companies, the global carriers aim to cover the key port ranges where services require mega vessels.

The recent past showed an increase in global stevedores, established by separating terminal functions from main line operations. Global stevedores focus on developing business by bidding for concessions and making acquisitions. An example is APM Terminals, which was established in 2001 as a separate terminal operator company of the Maersk Group.

7.3 Container terminal operations

Before going into actual container terminal layout development, it is important to understand the logistic process on container terminals. The logistic processes taking place on container terminals are described in this paragraph.

7.3.1 Terminal processes and equipment

At the quay

Prior to arrival of a vessel the containers to be unloaded have been identified (and those to be loaded have been arranged in the export stack in such a way that they can be transferred to the vessel in the right order).

Immediately after the vessel has made fast at the berth the lashings are taken off the containers above deck and the ship-to-shore (STS) gantry cranes (or portainers) start unloading. A modern STS gantry crane is as high as a cathedral, especially with their booms up. Fig. 7.20 presents Post Panamax STS gantry cranes at container terminal Altenwerder in Hamburg (Germany).



Figure 7.20: Post Panamax STS crane at Container terminal Altenwerder

These STS cranes are generally rail mounted. STS cranes are characterised by a boom, which can be lifted, as shown in Fig. 7.22, or pulled inward (when close to airports for instance). The cranes are provided with a trolley and a cabin, which moves with it, from which the crane driver (or operator) guides the trolley and the spreader to the right container on the vessel. The container is picked up and transported to the space between the seaward and landward leg of the crane, where it is lowered and placed on the transport vehicle in use between quay and stack. The development of STS cranes with growing vessel sizes over the years is depicted in Fig. 7.21. Mobile harbour cranes are also used for the loading and unloading of container vessels, but mainly on small container terminals.

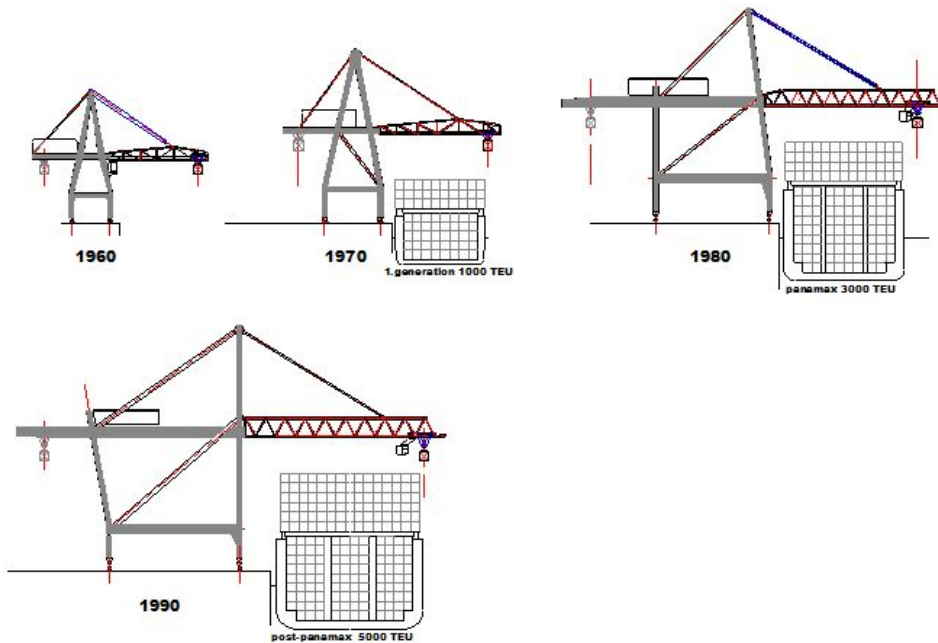

Figure 7.21: Development of STS-cranes

At present, the most common STS crane is based on an A-frame with tip-up boom. Refer to Figure 7-22, which is also providing typical dimensions for an STS crane with the capability to handle Post New Panamax vessels.

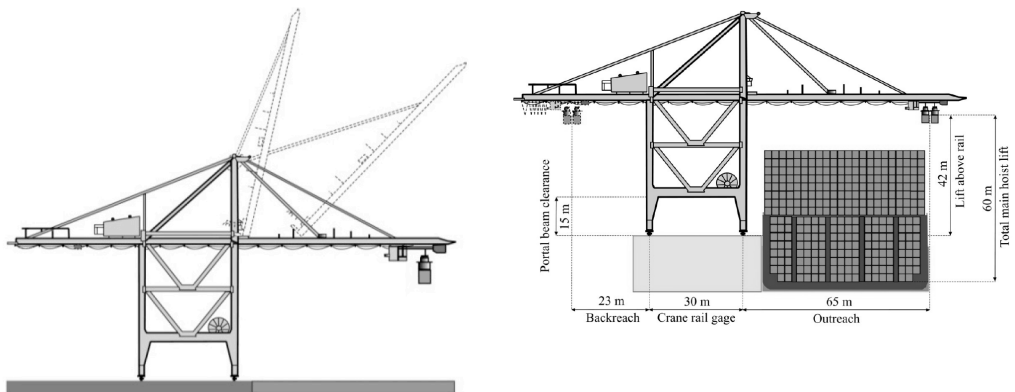

Figure 7.22: A-frame STS crane with typical dimensions for handling Post New Panamax vessels (Bartosek et al, 2013).

Some typical properties of STS cranes are:

- Lifting capacity: originally 400 kN, now increasing to 800 kN and above, to allow for twin/tandem handling
- Outreach: going up from 30 m for handling Panamax vessels

7 Container Terminals

- Rail gauge: to 70 m for handling Post New Panamax vessels varying from 15 m. to 35 m.
- Width between legs: min. 16 m. to allow oversized containers to pass
- Crane productivity: peak 40-50 moves / hr, average 20-30 moves / hr.

Crane productivity is a key indicator and one of the critical parts of overall terminal productivity. The productivity of a STS crane is measured by the number of moves per hour. One move equals a move of a container between vessel and transport vehicle or vice versa. Feeder vessels are being served by 1-2 STS cranes, while Post New Panamax vessels can be served by 6-8 STS cranes (Bartosek et al, 2013), see also Fig. 7.23. The STS cranes at the ECT Euromax terminal have a reach of 23 containers wide.

The STS cranes set the pace for the whole terminal. This means that the productivity of the fleet of STS cranes is extremely important for the commercial success of a container terminal. STS crane automation and the remote control of STS cranes are currently major trends that are profoundly reshaping crane operations. The main driver behind these trends is the need for cranes that have a lifting height of more than 50 meters. The need for such lifting heights is due to the larger ships such as the 18,000 TEU Triple-E class ships being put into service. With ships of this size, the travel distance of the trolley also increases and this requires the cranes to be run faster to maintain the productivity level. Moving human operators from the crane cabin and having them operate cranes by remote control and automation allows the full capacity of the cranes to be continuously utilized. It also opens up the possibility for the use of cranes with even higher speeds and accelerations yet to be built (<http://new.abb.com>, June 6, 2017)



Figure 7.23: 13,000 TEU COSCO Development being handled by six STS cranes at Euromax terminal in Rotterdam (source: Kees Torn, Flickr, 11-09-2011)

Between quay and storage yard

For the transport between the quay and the storage areas several options exist, depending on the size and the throughput of the terminal and on the preferences of its operator. In increasing order of sophistication these are:

- In the past forklift trucks were used, but nowadays toploaders are used (see Fig. 7.24). Toploaders are equipped with a spreader to pick up a container from above and are capable of handling loaded containers. Top loaders need sideway access to a stack, which can therefore be only two containers wide and requires much space between the stacks. On multipurpose terminals with limited container throughput and much space this type of equipment offers an economic solution. Empty container handlers are used in the empty container depot, their lifting capacity is smaller compared to top loaders. Empty container handlers pick up the containers sideways;
- Reach stacker (see Fig. 7.25). The difference with the FLT is that this machine handles the container by means of a boom with a spreader. Hence it can reach the second row of containers in a stack, which can therefore be four rows wide. However the space efficiency is still low. Another disadvantage is the relatively high front axle load (up to 100 tons), which asks for strong pavement;
- Chassis (see Fig. 7.26). Single trailers for use in the yard only, where they are moved by tractor units. The containers are stored on the chassis. This approach, quite customary in U.S. ports, has the disadvantage of low space utilisation, compared with the stack approach applied in Europe and Asia. However, it is very easy to select the correct container and move the container from the stack;
- Straddle Carrier (SC, see Fig. 7.27). For this equipment the stack consists of (not too lengthy) rows of containers, separated by lanes wide enough for the legs and tyres of the SC. Depending on the nominal stack height, 2- or 3-high, the SC can lift a container 1 over 2 or 1 over 3. Certainly in the latter case the SC becomes quite tall and difficult to manoeuvre since the driver cabin is on top. However, for reasons of space efficiency and flexibility the SC is quite popular among terminal operators.

The above four types of equipment deal with the transport from quay to storage yard and within the yard. In high capacity terminals the two functions are often separated, with the following two types only used for quay-yard and vice versa, and dedicated cranes within the stack:

- Multi Trailer System (MTS, see Fig. 7.28). A series of up to 5 trailers interconnected and pulled by one yard tractor, offers a substantial reduction of the number of drivers needed. The system, developed and manufactured in The Netherlands, has a special device to keep all trailers in line when making a turn. MTS is not a very common means of horizontal transport on the larger and modern terminals nowadays. On the other hand MTS can be a very suitable means of transport on dedicated interconnecting lanes between terminals in a port complex;
- Automated Guide Vehicle (AGV, see Fig. 7.29). Developed and firstly implemented by ECT on the Delta-SeaLand terminal on the Maasvlakte. They are fully automated and therefore mean a further drastic reduction of manpower.

7 Container Terminals



Figure 7.24: A toploader (source: www.taylormachineworks.com)



Figure 7.25: A reach stacker (source: ECT)

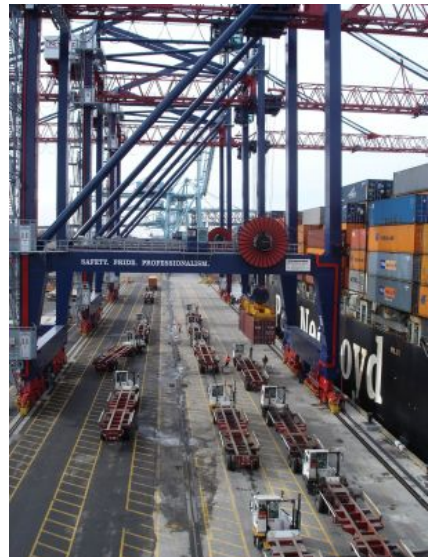

Figure 7.26: Chassis beneath STS crane at New York Container Terminal (source: www.portstrategy.com)



Figure 7.27: A straddle carrier (source: ECT)



Figure 7.28: Multi Trailer System (MTS) (source: Terberg Benschop)

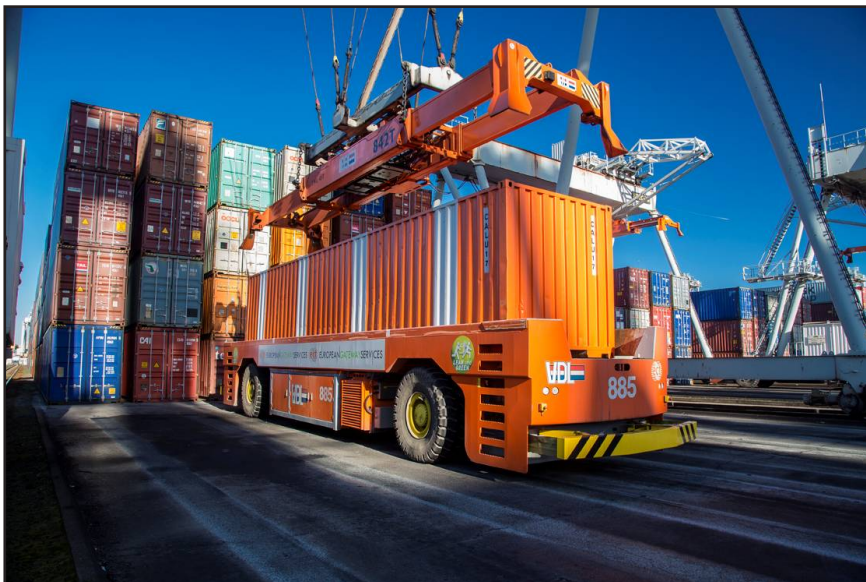

Figure 7.29: Automated Guided Vehicle (AGV) (source: ECT)

- Lift AGVs are a further development of the proven AGV technology. Unlike conventional AGVs, the lift AGV has two active lifting platforms. These enable the vehicle

7 Container Terminals

to lift and place containers independently on transfer racks in the interchange zone in front of the stacking cranes. Two 20' containers can be handled independently of each other or one container of any size. This can result in shorter downtimes and increased working frequency.



Figure 7.30: Lift Automated Guided Vehicle (Lift-AGV) (source: Terex® Gottwald)

ADVANTAGES	DISADVANTAGES
<u>Top loader / Reach stacker (RS)</u>	
<ul style="list-style-type: none"> ▪ <i>low investment equipment</i> ▪ <i>simple / flexible in operation</i> 	<ul style="list-style-type: none"> ▪ <i>much storage space</i> ▪ <i>labour intensive</i>
<u>Straddle carrier</u>	
<ul style="list-style-type: none"> ▪ <i>high throughput capacity</i> ▪ <i>one type of equipment for entire terminal</i> 	<ul style="list-style-type: none"> ▪ <i>complicated equipment</i> ▪ <i>high investment and maintenance costs</i> ▪ <i>highly qualified personnel needed</i> ▪ <i>labour intensive</i>
<u>Automatic Guided Vehicle (AGV)</u>	
<ul style="list-style-type: none"> ▪ <i>minimum labour costs</i> ▪ <i>high throughput capacity</i> 	<ul style="list-style-type: none"> ▪ <i>high investment and maintenance costs</i> ▪ <i>complicated and sensitive equipment</i>
<i>Box 7-1: Quay to storage transport systems</i>	

Within the storage yard

The MTS and AGV's deliver the containers outside the stacks and for further handling within the stack separate equipment is needed. Various types of gantry cranes are used as described below:

- Rubber Tyred Gantry (RTG, see Fig. 7.31). This gantry crane is commonly used in stacks up to about 6 containers wide and about 5 high. They are flexible (can be moved from one stack to another), but require good subsoil conditions or a track with adequate foundation in view of the relatively high wheel loads;
- Rail Mounted Gantry (RMG, see Fig. 7.32). Where the subsoil conditions are less favourable the RMG is preferable, because the rails spread the load better. Notwithstanding the greater span of the crane (up to 10 containers wide) the crane bogeys provide for lesser wheel loads. Also the rail can be more easily supported, if needed.
- While most RMG's have the rails at ground level, a terminal in Singapore has an overhead crane running on rails on beams, supported by concrete columns at 18 m above ground level, referred to as Overhead Bridge Crane (OBC);
- Automated Stacking Crane (ASC, Fig. 7.33:). The first cranes of this type were introduced by ECT in conjunction with the AGV's. They reach across about 10 containers and operate 1 over 4 high, in the most terminals (for instance ECT Euromax terminal at Maasvlakte, Rotterdam

ADVANTAGES	DISADVANTAGES
<u>Rubber tyred gantry (RTG)</u>	
<ul style="list-style-type: none">▪ good space utilisation▪ flexible, high occupancy rate▪ reasonable productivity	<ul style="list-style-type: none">▪ high maintenance
<u>Rail mounted gantry (RMG)</u>	
<ul style="list-style-type: none">▪ good space utilisation▪ reliable, low maintenance▪ automation and relative high productivity possible	<ul style="list-style-type: none">▪ high investment▪ inflexible
<u>Automated stacking crane (ASC)</u>	
<ul style="list-style-type: none">▪ minimum labour costs▪ high capacity	<ul style="list-style-type: none">▪ higher investment compared to RMG

Box 7-2: Equipment within the stacks



Figure 7.31: Rubber Tyred Gantry (RTG) (source: Kalmar)



Figure 7.32: Rail Mounted Gantry (RMG) in stack of Container Terminal Altenwerder (Hamburg, Germany) (source: hhla.de)



Figure 7.33: Automated Stacking Crane (ASC) (source: ECT)

From storage yard to hinterland transport

The transport of containers between the stacks and the truck stations (and vice versa) is done mostly by the equipment that is also used in the stack. For instance at a terminal where straddle carriers are applied, straddle carriers bring and position the containers on the

7 Container Terminals

trucks. Straddle carriers can move over the truck. From the yard to a rail- or inland barge terminal various types of equipment are used, depending on the distance. The same considerations apply as for the equipment between quay and storage yard.

The gate

For road transport this is the central element on the terminal. Here the import containers leave the terminal and the export containers arrive. All entries and departures are recorded and customs formalities are dealt with. High capacity terminals require advanced information technology to avoid frequent queues and long waiting times for the trucks.

As described in PIANC (2014), the gate facilities are usually divided into an entrance or receiving gate for trucks entering and a separate exit gate for trucks exiting the terminal. The number of entrance and exit lanes required is determined by the predicted level of traffic for the terminal

Many modern terminals using AEIS (Automatic Equipment Identification System) standardised by ISO/TC 104/SC 04/WG 02 “AEI for containers and container related equipment”) have an entrance gate of the pre-gate system type. The pre-gate system divides the gate procedure into two parts and reduces the required time at the gate itself and consequently reduces the number of required lanes and site area:

- At position 1 (the necessary information such as booking numbers is exchanged between a clerk located in a control room and the driver of the truck, using an electronic device. An AEIS reader puts the container into the terminal’s computer system.
- After this the truck is driven to the gatehouse (position 2) where a final inspection can be carried out.

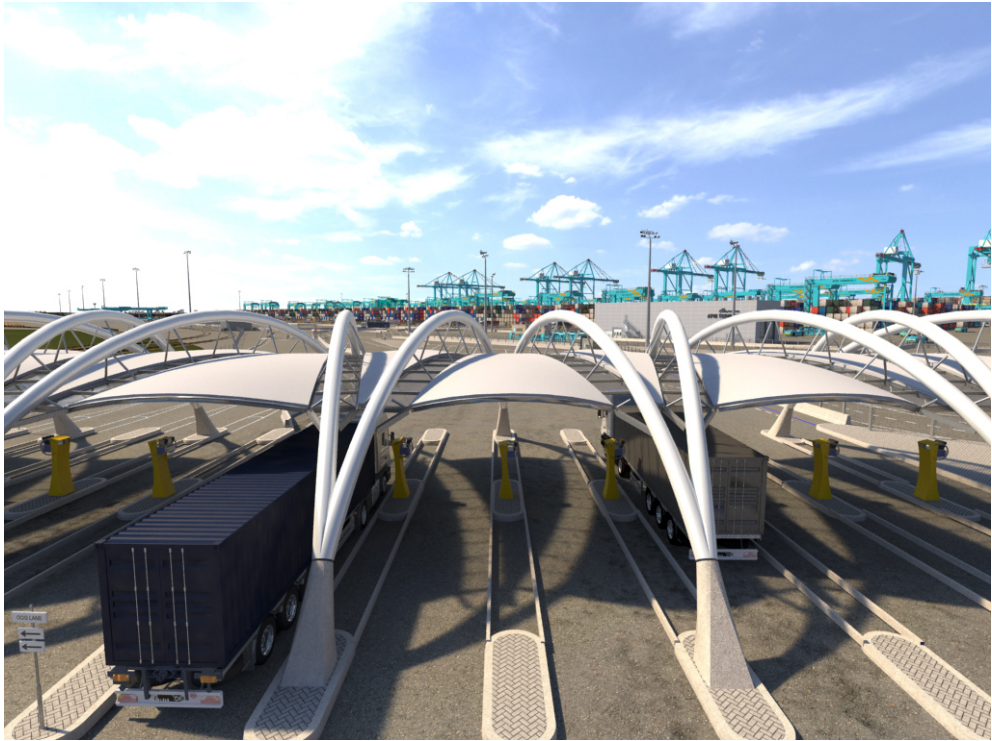

*Figure 7.34 The gate (canopy) at APMT Maasvlakte 2 terminal, artist impression
(source: APMT)*

As described in PIANC (2014), the terminal gate often has to provide space to accommodate additional port functions such as:

- Port Security and ISPS compliance. The requirement is to verify the identity of anyone entering or exiting the terminal through the demarcation (usually a fence) between the port and terminal area proper.
- Radiation Detection to incoming and outgoing containers. This check is accomplished by special mobile or fixed equipment called Radiation Portal Monitors (see also Section 7.4.12).
- Customs inspections. Usually an area near the exit gate has to be set aside for the customs officials to be able to selectively inspect the content of incoming containers for contraband and collect the customs duty. In many terminals in the developing world the customs inspection procedure is time consuming and results often in a bottleneck in the flow of containers, and in such cases separate facilities should be provided. The application of X-ray equipment is quite common nowadays and also more and more in developing countries.
- Reefer and agriculture inspections which requires an area to be set aside similar to the Customs inspection above.
- Port health inspections
- Weighbridge. One or more of these may be required for a variety of reasons such as verifying cargo weights or checking for vehicle weights that exceed highway limits.

- Damage inspections. It is normal to have cameras incorporated in the gate complex for the general external inspection of containers for insurance purposes.

7.3.2 Container flows and modal split

The dimensions of all planning elements are a function of the yearly averaged flows of containers, which are presented in the so-called modal split. The modal split gives the (forecasted) numbers of containers entering and leaving the terminal via the sea (main lines, feeder lines and short-sea lines), road, rail and IWT.

As shown in Fig. 7.35, the incoming containers are split between import and those which leave the port again by sea, the transshipment containers (see also Section 2.4.1). In the same way there may be a small portion of containers which enters from the land and leaves by (another) landside modality (Van Beemen, 2008):

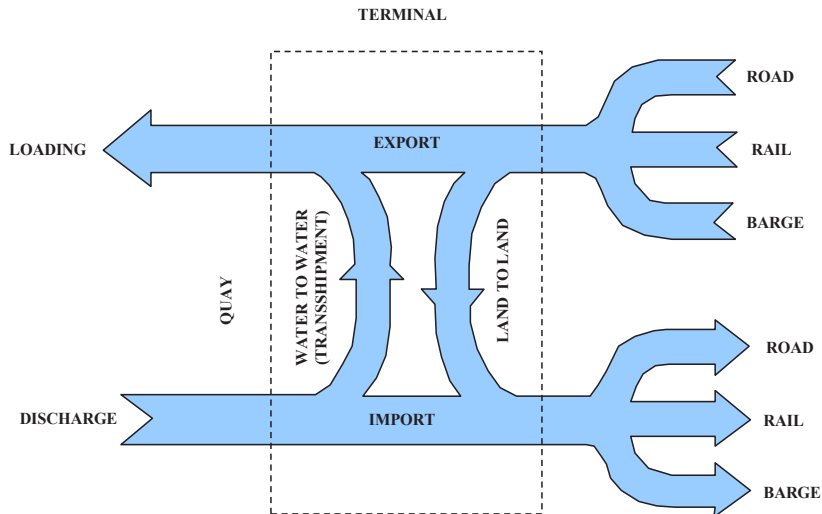

Figure 7.35 Container flows and modal split

- The import flow is the flow of containers being discharged from a vessel and finding its way to the hinterland;
- The export flow is the flow of containers coming from the hinterland and being loaded on a vessel;
- The sea-to-sea flow is the flow of transshipment containers which are discharged from a deep-sea or feeder vessel and are later loaded on another deep-sea or feeder vessel;
- The land-to-land flow may have different reasons. They are mostly empty containers being returned to the empty depot and leaving again for reloading with local export products: they can also be containers coming in by one landside modality, e.g. truck, and then leave for an inland destination by another modality, e.g. train.

An example of a simplified modal split is shown in the box below, with arbitrary numbers. The assumption that the flows are balanced per transport mode is clearly a simplification of reality. In most cases there is a distinct imbalance. The throughput figures shown include the empty containers, which normally are given explicitly, because they may be stacked and handled more economically than loaded containers.

Calculation example

Figure 7.36 shows an example calculation for a terminal with a quay throughput 1.2 million TEU per year. Light blue cells indicate input values, which in practice will be provided or will have to be assumed. Fig. 7.36 shows the container flows through the terminal. Note that the number of terminal visits for transshipment traffic is half the transshipment quay throughput. A transshipment container will go over the quay twice (once during discharge, once during loading onto another ship), while only making one terminal visit. The land-to-land flow visits the terminal but does not move over the quay.

	% of quay throughput	Quay throughput TEU/year	Terminal visits TEU/year
Import	40.2%	482,400	482,400
Export	38.4%	460,800	460,800
Transshipment	21.4%	256,800	128,400
Land to land			50,000
Total		1,200,000	1,121,600

[%]	Import	Export	Transshipment	Land to land
Laden	70.3%	62.0%	70.3%	0.0%
Empty	10.2%	35.3%	10.2%	100.0%
Reefer	18.4%	2.2%	18.4%	0.0%
OOG	1.1%	0.5%	1.1%	0.0%
Sum	100.0%	100.0%	100.0%	100.0%

Land modal split	Out	In
Road	61%	70%
Rail	23%	25%
Barge	16%	5%

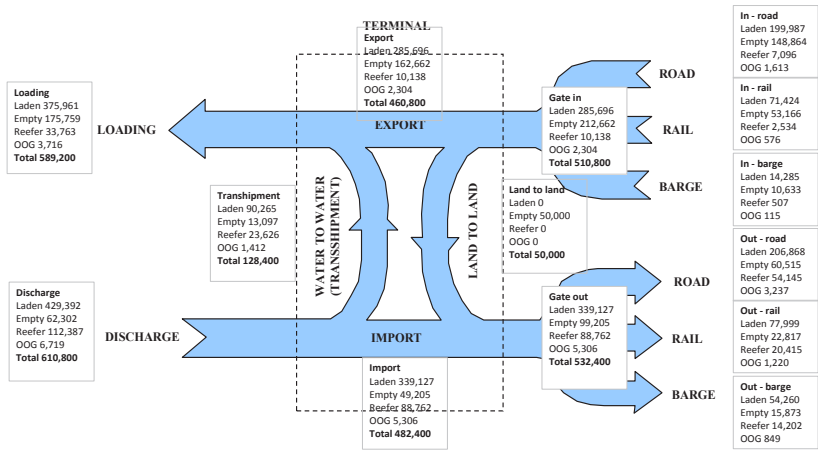

Figure 7.36 Example container flow

As an example the laden container flow is calculated. The starting points of the calculation are the import, export, transshipment and land to land flows. Then, by rules of conservation on the nodes, the other container flows are calculated:

7 Container Terminals

- *Laden import flow.* The import flow is 482,400 TEU/year. 70.3% of this flow is laden containers, hence 339,127 TEU/year;
- *Laden export flow.* The export flow is 460,800 TEU/year. 62.0% of this flow is laden containers, hence 285,696 TEU/year;
- *Laden transshipment flow.* The transshipment flow is 128,400 TEU/year (terminal visits). 70.3% of this flow is laden containers, hence 90,265 TEU/year;
- *Laden land to land flow.* The land to land flow is 50,000 TEU/year. This consists of empty containers only, hence the laden land to land flow is 0 TEU/year;
- *Laden discharge flow = import + transshipment = 339,127 TEU/year + 90,265 TEU/year = 429,392 TEU/year;*
- *Laden loading flow = export + transshipment = 285,696 TEU/year + 90,265 TEU/year = 375,961 TEU/year;*
- *Laden gate out flow = import + land to land = 339,127 TEU/year + 0 TEU/year = 339,127 TEU/year;*
- *Laden gate in flow = export + land to land = 285,696 TEU/year + 0 TEU/year = 285,696 TEU/year.*

The gate in and gate out traffic is split into road, rail and barge transport, based on the input parameters. The above calculation can also be performed for the empty, reefer and OOG container flows.

The modal split gives the transport flows in number of containers. This is relevant for the quay length design, because the container crane production is also in container (moves) per hour. For the capacity of the storage yard the division between 20 ft and 40 ft containers has to be known, because the surface area depends on this. The other capacity calculations are therefore also carried out in TEU. The above division is determined by the TEU-factor, which is often characteristic for different types of ports and can be derived from statistical data.

$$\text{TEU factor} \quad f_{TEU} = \frac{N_{20'} + 2N_{40'}}{N_{20'} + N_{40'}} \quad (7.1)$$

in which:

$N_{20'}$ = number of TEU's

$N_{40'}$ = number of FEU's

When the ratio of 20 ft to 40 ft containers is 4 to 6, the TEU-factor amounts to 1.6. In developing countries rather low TEU-factors are encountered, indicating that a large percentage of goods is transported in 20 ft containers. The main line traffic shows a shift towards 40 ft containers over the years, which is expected to continue for some time.

The initial planning is often based on relatively simple design formulae, as presented in the subsequent sections, or Queuing Theory. The final layout is may be optimised by me-

ans of simulations, which permit to analyse the complete terminal process, including the stochastic variation of vessel arrivals, crane and other transport equipment availability, and container arrivals/departures via land. However precise and reliable input is necessary to arrive at reliable simulation model output. Also the stochastic variation of vessel arrivals is limited nowadays because of tight sailing schedules. Tramp shipping as occurred during the early years of container shipping hardly occurs anymore.

7.3.3 Terminal archetypes

The relation between the main container flows as elaborated in Section 7.3.2 mainly determines the type of terminal.

Container terminals can be divided in the following two categories:

- Gateway terminal;
- Transshipment or Hub terminal.

Gateway terminals form the gate to and/or out of a vast hinterland with emphasis on import and export of cargo. The most important containers flows are import and/or export. Examples are the ports of Shanghai (China) and Busan (Korea). Import in these gateway terminals consists for a considerable part of empty containers that are being filled with industrial products coming from the hinterland. It can also be the other way around: import mainly consisting of loaded containers and export of empty containers. This is for instance happening in Jeddah (Saudi Arabia) and Kuwait City.

The development of round-the-world services is one of the reasons that specialized transshipment ports have emerged at places far away from the hinterland which historically determined port site selection. Transshipment ports focus on sea to sea flow of containers and as a result, the landside facilities are of less importance compared to Gateway ports. Examples are the port of Hong Kong (PRC), Singapore, Aden (Yemen), Salalah (Oman), Dubai (UAE), Gioia Tauro (Italy), Algeciras and Valencia (Spain), Malta, Tanger Med (Morocco) and Port Said (Egypt).

Regarding container handling, the Port of Rotterdam is a mix of a gateway and transshipment port. Rotterdam has a relatively large hinterland and thus attracts a significant volume of gateway containers. That is the reason why the large container carriers deviate from their round-the-world route to call at the Port of Rotterdam. It makes the Port of Rotterdam also attractive as a container feeder hub for Scandinavia, Baltic region and a part of the United Kingdom.

7.3.4 Size of the container terminal

PIANC (2014) distinguishes the following terminal size categories:

- Small terminal: less than 250,000 TEU per annum;
- Medium terminal: 250,000 to 750,000 TEU per annum;
- Large terminals: more than 750,000 TEU per annum.

7 Container Terminals

The 10 world largest container ports (2015) are listed in Table 7.3.

Table 7.3: Top 10 container ports (source: World Shipping Council)

Rank	Port, Country	Volume 2015 (Million TEU)	website
1	Shanghai, China	36.54	www.portshanghai.com.cn
2	Singapore	30.92	www.singaporepsa.com
3	Shenzhen, China	24.20	www.szport.net
4	Ningbo-Zhoushan, China	20.63	www.mardep.gov.hk
5	Hong Kong, S.A.R., China	20.07	www.mardep.gov.hk
6	Busan, South Korea	19.45	www.busanpa.com
7	Qingdao, China	17.47	www.qdport.com
8	Guangzhou Harbor, China	17.22	www.gzport.com
9	Jebel Ali, Dubai, United Arab Emirates	15.60	www.dpworld.ae
10	Tianjin, China	14.11	www.ptacn.com

Examples of large terminals are given in Fig. 7.37 and Table 7.4, illustrating the capacity and ownership characteristics of five deep-sea container terminals on the Maasvlakte in the Port of Rotterdam. The terminals have an individual capacity ranging from 2.4 million to 8 million TEU.

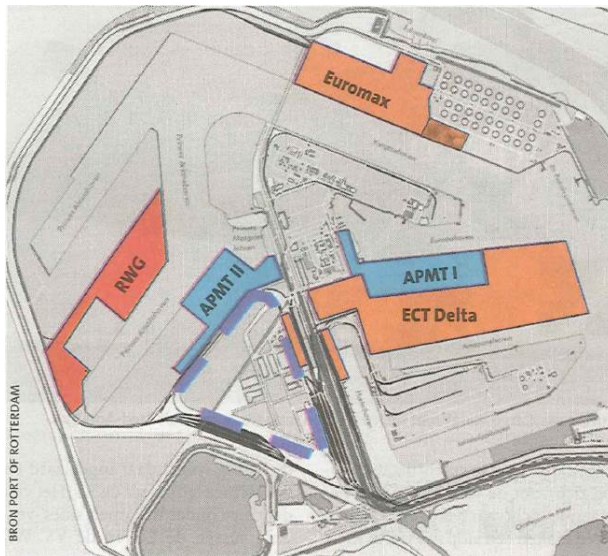

Figure 7.37 Location of the container terminals at Maasvlakte, Rotterdam

Table 7.4: Deep-sea terminals Maasvlakte, Port of Rotterdam

	ECT Delta	Euromax	APMT-Rotterdam	APMT-Rotterdam II	Rotterdam World Gateway
Share holders	Hutchison	ECT 51%, Cosco, K-Line, Yang Ming, Hanjin for 49%	APM terminals (100% A.P. Moller-Maersk)	APM terminals (100% A.P. Moller-Maersk)	DP World 30%, APL, MOL, Hyundai each 20%, CMA-CGM 10%
Surface	265 hectare	121 hectare	115 hectare	86 hectare	110 hectare
Quay length	3600 m. deepsea, 370 m barge/feeder	1500 meter	1600 m deep-sea	1000 m deep-sea, 500 m barge/feeder	1150 m deep-sea, 550 m barge/feeder
Number of ship-to-shore cranes	36	12	13	unknown	11
Annual capacity	8 million TEU	5 million TEU	3.4 million TEU	2.7 million TEU	2.4 million TEU

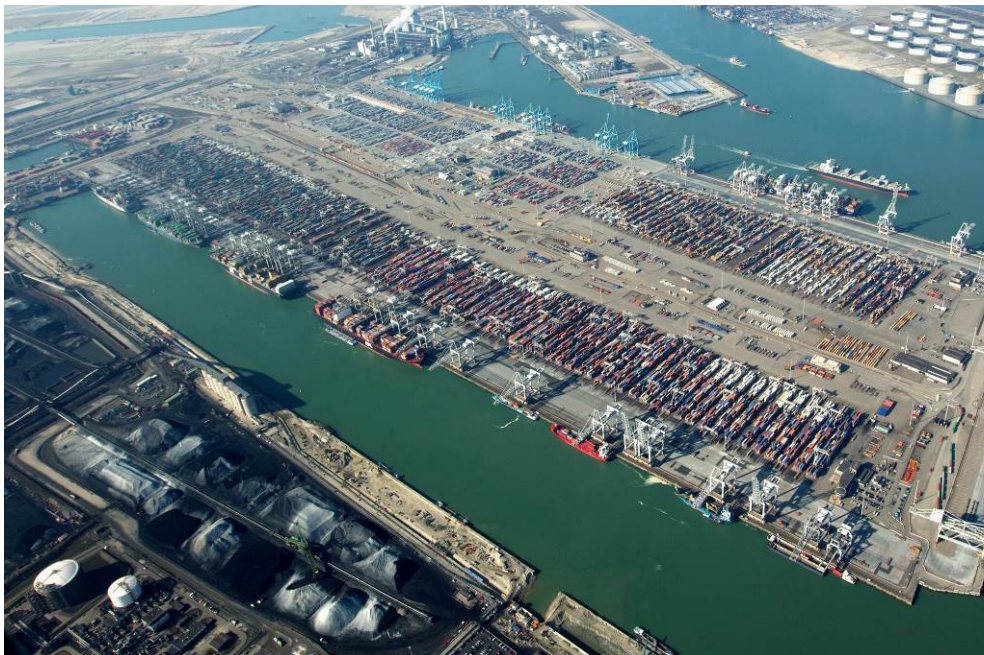

Figure 7.38 ECT delta terminal (source: ECT)

A typical example of a small terminal is the Ormsund container terminal in Oslo. Its annual capacity is 160,000 TEU, see Figure 7.39.



Figure 7.39: Overview of the Ormsund container terminal in the Port of Oslo
(source: Port of Oslo)

7.3.5 Terminal automation

Shipping lines are pressing both larger and smaller terminals, to increase the level of services offered and, at the same time, reduce handling costs. Labour expenses take up a large part of those handling costs. For large terminals, automated container handling has proven itself a reliable and effective way to reduce operational costs (Rademaker, 2007):

In terminal operations, three levels can be identified where automation can be applied:

- Level 1: Exchange of information. At this level automation means the electronic management and exchange of information between shipper, carrier, haulier, receiver and terminal operator;
- Level 2: The processes at the terminal are controlled and planned. At this level all information is processed and used for the planning and management of operations. Automation at this level indicates the use of information systems to take planning decisions and control terminal operations;
- Level 3: The actual handling of containers is the final level for automation. At this level automation indicates partial or complete robotised operation of equipment.

A recent example of a large, fully automated terminal is the new terminal of APM terminals on Maasvlakte 2. It has an initial capacity of 2.7 million TEU. The terminal design concept is based on using ship-to-shore (STS) cranes, being remotely operated from a central control room, that unload containers from the vessel and place them directly onto a fleet of Lift Automated Guided Vehicles (Lift AGVs). The Lift AGVs can carry two 20 ft containers at

a time and shuttle them at a speed of 22 kilometres per hour from the quay to the container yard using an on-board navigation system that follows a transponder grid. Once the Lift AGV arrives at its programmed destination it lifts the containers into a series of storage racks. Next, an Automated Rail-Mounted Gantry (ARMG) crane arrives to take the container from the rack to its next designated location in the stack.



Figure 7.40: Overview of the container terminal AMPT Maasvlakte 2, artist impression (source: APMT)



Figure 7.41: ARMG and truck transfer docks, AMPT Maasvlakte 2, artist impression (source: APMT)

7 Container Terminals

Another example of a fully automated terminal is Altenwerder Container Terminal in Germany. It became operational in 2002, see Fig. 7.42.



Figure 7.42: Overview of the container terminal Altenwerder (source: CTA)

7.4 Layout development

On the basis of container terminal operations, as described in the foregoing paragraph, a terminal layout can be developed.

7.4.1 Container terminal components

The main container terminal components are depicted in Figure 7.43.

The quay plus apron, the storage yard, the container truck transfer area, rail terminal and other terminal components are described in the following paragraphs.

7.4.2. Typical container terminal layout

The terminal layout depends to a large extent on the selected yard handling systems. An illustration of this fact is the orientation of the containers in the stack: on terminals with SC the length axis of the containers can be either perpendicular or parallel to the waterfront. In case the horizontal transport is carried out by means of MTS or AGV, the orientation is more likely to be perpendicular to the quay, containers being delivered or collected along the seaward face of the stacks.

This implies that the planning of a new terminal is a multidisciplinary exercise in which the preference of the operator for a specific stacking system in combination with a specific horizontal transport system often forms the starting point.

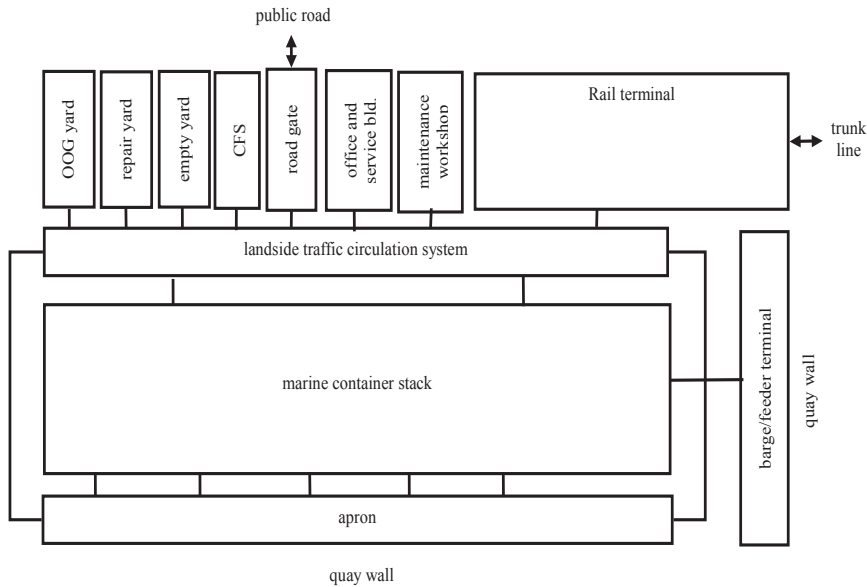

Figure 7.43: Terminal components

For the layout the following planning elements have to be determined and quantified:

- Quay length and number of container cranes;
- Apron area;
- Storage area;
- Container transfer area (to truck and rail);
- Buildings (container freight station (CFS), office, gate and workshops). On large container terminals less and less CFS facilities can be found.

7 Container Terminals

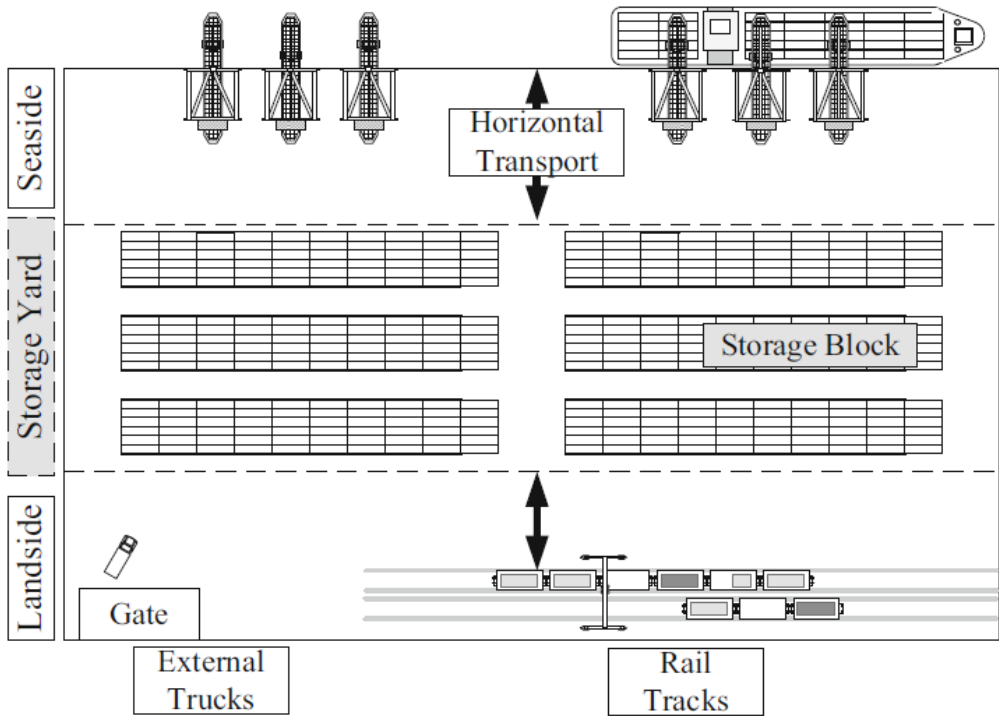

Figure 7.44: Typical container terminal layout (Böse, 2011)

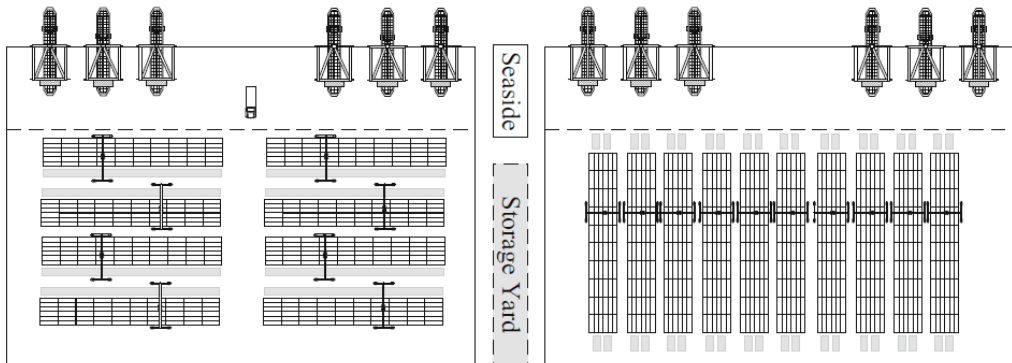

Figure 7.45: Parallel (left) versus perpendicular stacking (right) (Böse, 2011)

Typical terminal layouts for frequently applied handling systems are being presented in Figures 7.46, 7.47 and 7.48:

- SC system;
- RMG system;
- RTG system.

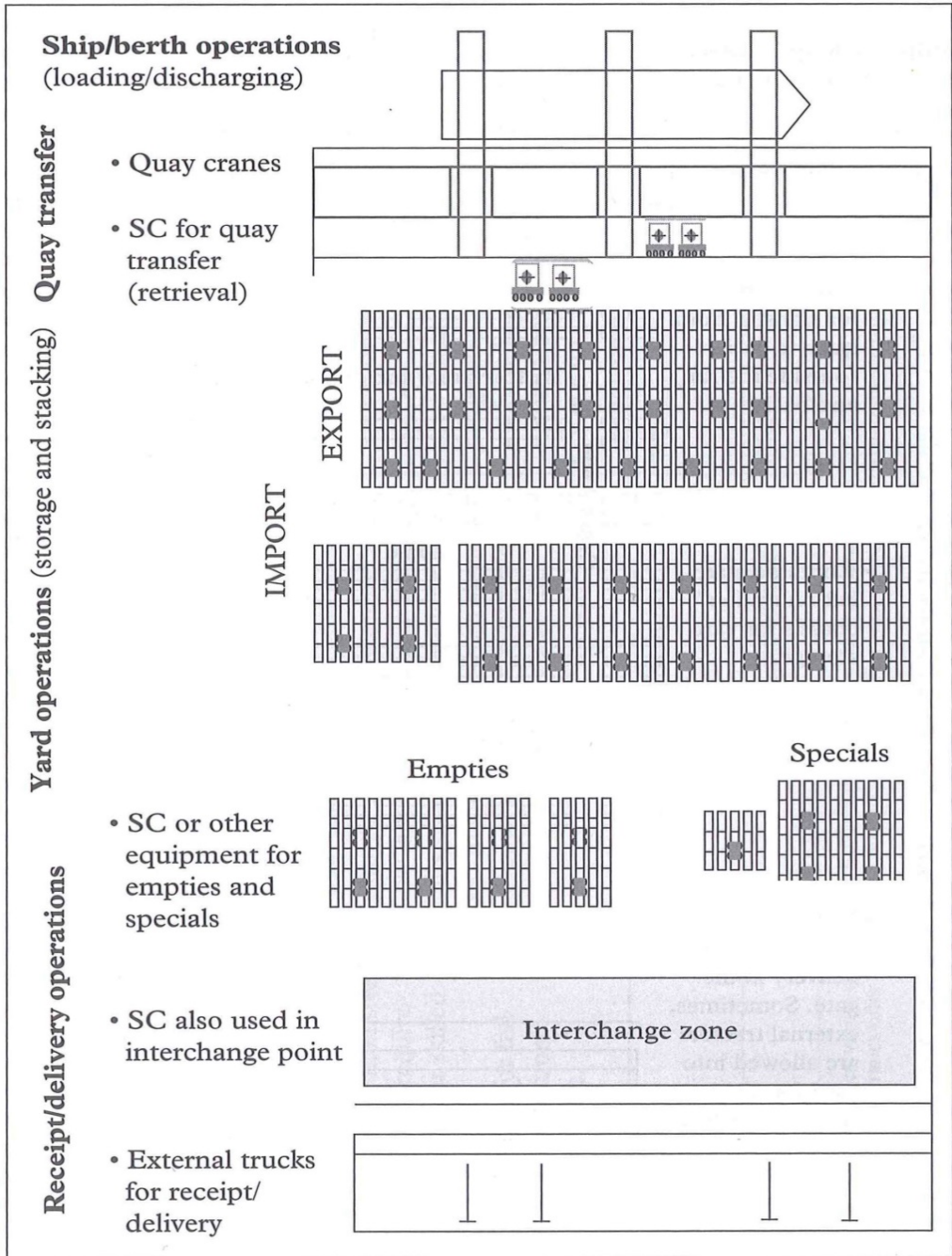

Figure 7.46: Typical layout for straddle carrier operations (Bichou, 2009)

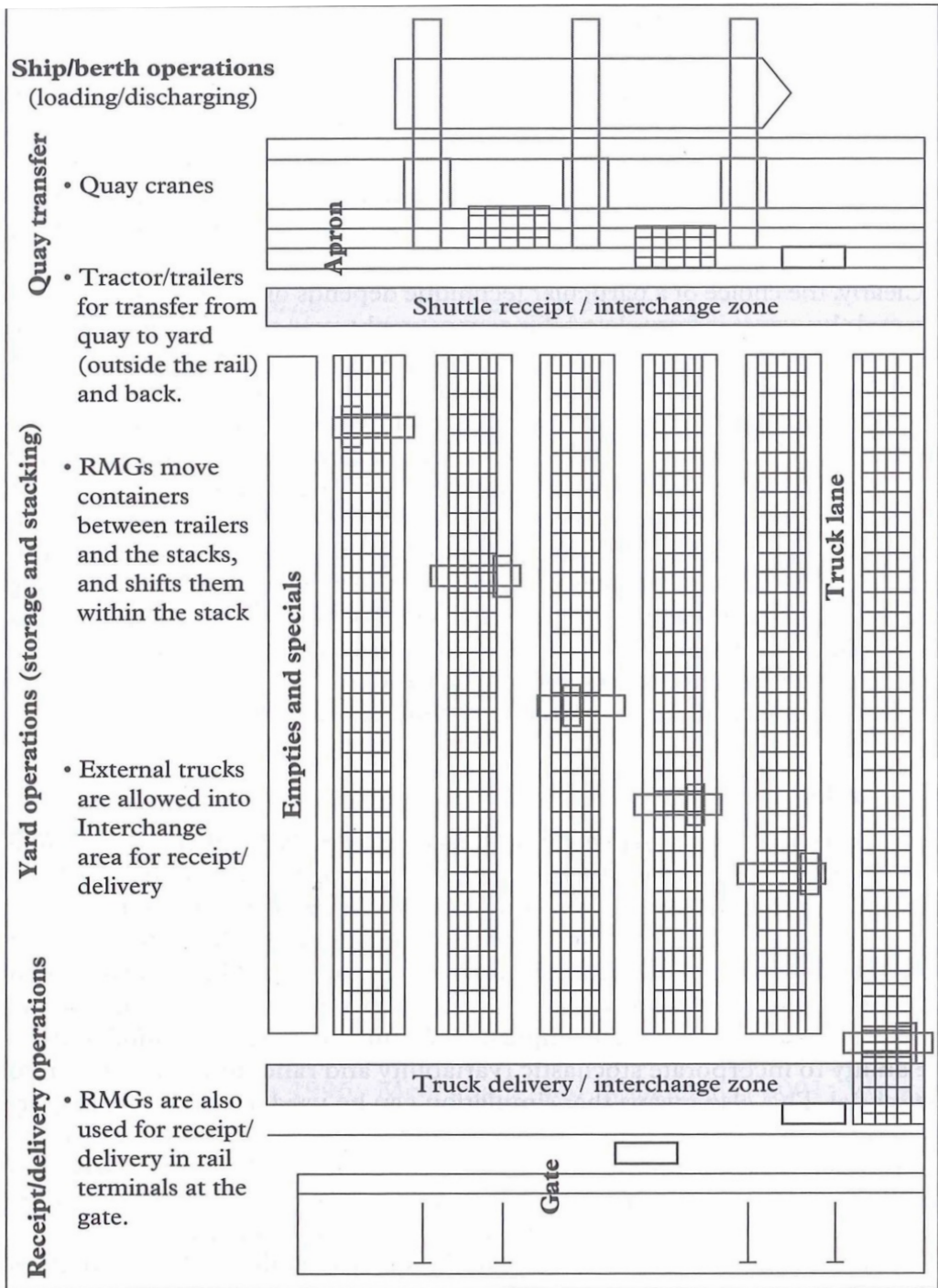

Figure 7.47: Typical layout for RMG operations (Bichou, 2009)

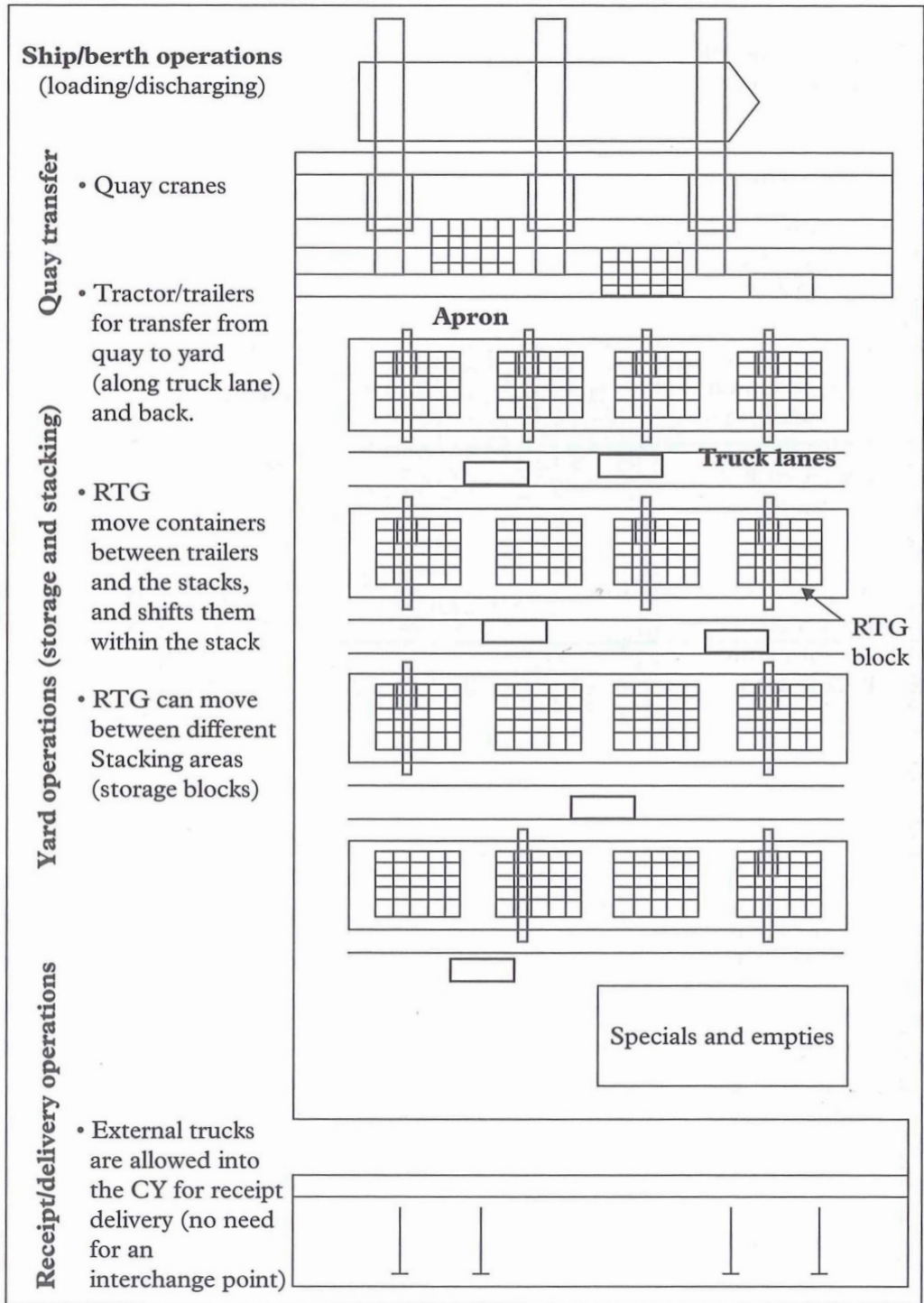

Figure 7.48: Typical layout for RTG operations (Bichou, 2009)

7.4.3 Quay length and number of STS cranes

A first approximation of the number of berths and hence of the quay length is made on the basis of an estimated berth productivity. Such an estimate is made as follows:

$$c_b = P \cdot f_{TEU} \cdot N_{cb} \cdot n_{hy} \cdot m_b \quad (7.2)$$

c_b	=	average annual productivity per berth	[TEU/yr]
P	=	net production per crane	[moves/hr]
f_{teu}	=	TEU factor	[-]
N_{cb}	=	number of cranes per berth	[-]
n_{hy}	=	number of operational hours per year	[hrs/yr]
m_b	=	berth occupancy factor	[-]

The net crane productivity P is subject of much confusion, due to the lack of a commonly accepted definition. In Equation (7-2) P is the average number of containers moved from ship to shore and vice versa during the period between berthing completed and de-berthing started. This period includes all sorts of “unproductive” intervals such as for crane repositioning from one bay to another, removal of hatches and placing them back, time lost between shifts and simple repairs to the cranes. A peak (technical) crane production of 50-60 moves per hour is easily reduced to a net productivity of 25 moves per hour by above losses.

For a modern terminal receiving 4000-5000 TEU ships on a regular basis and working 24 hours per day, 360 days per year, the average call size is assumed to be about 2000 TEU, with a length of 250 m. We would expect on average 3 cranes to be available per berth and a rather low berth occupancy of 35%. A net crane productivity of 25 moves per hour and a TEU-factor $f_{TEU} = 1.5$ give a berth productivity of 340,000 TEU per year.

Subsequently the required number of berths n is calculated as:

$$n = \frac{C}{cb} \quad (7.3)$$

where C is the total number of TEU entering and leaving the terminal by seagoing vessels (including empties). For a throughput of 2 million TEU/year one would need about 6 berths with the above productivity.

It is stressed that this estimation is very rough and does not even account for the time needed for berthing and de-berthing. It should be followed by a more precise calculation as outlined below. However, this approach gives good insight in the importance of various parameters. Some comments are relevant in this respect:

- A berth occupancy of 0.35 is rather low, but often encountered due to the stringent conditions posed by the shipping lines with respect to minimum waiting time;

- A berth productivity of 340,000 TEU/yr is higher than most terminals can achieve at present. On many container terminals in developing countries the berth productivity is more in range of 100,000-150,000 TEU/yr. Although the berth occupancy is normally very high (80-90%, which creates in turn long waiting times for the vessels) this can not compensate the rather low TEU-factor, the frequent breakdowns of equipment and the low crane productivity. On modern hub terminals the berth productivity can be as high as 500,000 TEU/yr, due to the high TEU-factor, larger average vessel size and more cranes per vessel, each with a high net productivity;
- The number of STS cranes per berth depends on several factors:
 - The range of vessel sizes and the (weighted) average size;
 - The number of berths;
 - The stowage plan;
 - The maximum number of cranes which can operate on one vessel

Along a conventional quay cranes can work on every other bay. For practical reasons (including the movements of other transport equipment between the STS cranes and the storage yard) Post Panamax vessels have not more than 5 cranes working simultaneously. Smaller vessels have fewer cranes. When a new terminal would start with one berth only, but should be able to handle a Post Panamax vessel efficiently, 5 cranes are needed for that single berth. For the latest generation of vessels this is not enough, refer to Fig. 7.23. On the other hand, when a quay consists of several berths, the low berth occupancy permits to reduce the average number of cranes per berth. For the above example with 6 berths a total of 18 cranes is therefore justified, in a first approximation.

The second and more accurate method for determining quay length requires also a more precise input in terms of expected annual number of calls N_{sy} and the average call size c_c , i.e. the number of containers unloaded and loaded per call. The relation with C becomes:

$$C = N_{sy} \cdot c_c \quad (7.4)$$

From the parcel size, the net crane productivity and the number of cranes per berth the average service time is derived. By applying queuing theory the number of berths (service points in the system) and the related average waiting time are obtained, assuming random vessel arrivals. It will be seen that relatively low berth occupancy rates are found, to keep the waiting time low (Groenveld, 2001).

In practice most container vessels sail on fixed routes and within tight schedules. Unless significant delays occur due to bad weather or vessel repairs, the vessels arrive within about 1 hour of their scheduled time of arrival. This means that the assumption of random arrivals is conservative. Most likely the berth occupancy can be increased to 0.5-0.6 without significant waiting time resulting for the majority of the vessels. In the competitive stevedoring market it is not easy to reduce the service level demanded by the shipping line. It will be interesting to check the berth occupancy of a terminal operated by the shipping line itself.

Another aspect of this service level is the maximum time spent in port, which is stipulated at 24 hours. The latest class of Post Panamax vessels with 6000 TEU and above can not be handled within this time period, when the parcel size exceeds 4400 TEU (assuming 1 hour for berthing and 1 hour for departure):

$$P \cdot f_{TEU} \cdot N_{cb} \cdot (24 - 2) = 25 \cdot 1.6 \cdot 5 \cdot 22 = 4400 TEU$$

Solutions to this problem are sought in various directions, including improvement of the crane productivity by handling two 40' boxes (or four 20' boxes) simultaneously and by further automation and reduction of the cycle time.

Quay length

Finally the quay length is calculated, based on the number of berths (whether estimated or determined by means of queuing theory).

For a single berth the quay length is determined by the length of the largest vessel frequently calling at the port, increased with 15 m extra length fore and aft for the mooring lines. For multiple berths along a straight continuous quay front the quay length is based on the average vessel length, as follows:

$$L_q = \begin{cases} L_{s,max} + 2 \cdot 15 & \text{for } n=1 \\ 1.1 \cdot n \cdot (\bar{L}_s + 15) + 15 & \text{for } n>1 \end{cases} \quad (7.5)$$

This allows for a berthing gap of 15 m between the vessels moored next to each other and an additional 15 m at the two outer berths. The factor 1.1 follows from a study carried out by UNCTAD. For a number of actually observed vessel length distributions and for the ratio average berth length / average vessel length as a variable, the probability of additional waiting time as a result of simultaneous berthing of several above-average vessels was determined (UNCTAD, 1985). From this the following graph resulted.

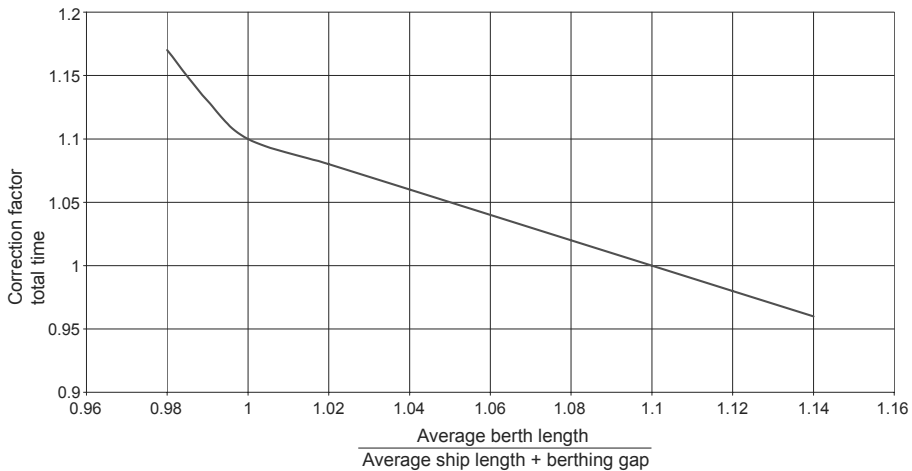

Figure 7.49: The correction factor total port time

The correction factor for total port time represents the additional waiting time. It is shown that with an average berth length equal to 110% of the average berth length + berthing gap, no additional waiting time occurs.

With increasing number of berths in a row, the correction factor will theoretically reduce to 1.0. In practice this is not the case, because only rarely vessels will be shifted during operations in view of the additional delays this causes.

7.4.4 Apron area

Once the quay length has been determined, the layout of the apron area can be completed. Along a line perpendicular to the waterfront one encounters the following lanes:

- A setback of 3-5 m between the coping and the waterside crane rail, to provide access to the vessels for crew and for supplies and services. This space is also necessary to prevent damage to the crane by the flared bow of the vessel during berthing under some angle. In the setback area are bollards and shore power connection pits;
- The crane track spacing, which is primarily determined by considerations of crane stability. A second aspect is the space required for the transport equipment and ATL removal/application. On most terminals the containers are dropped off or picked up by the STS crane within the space between the crane rails. When five STS cranes are working on one vessel, each has transport equipment lining up, which preferably have their own lane for reasons of safety. And depending on the number of crossings of the landward rail along the length of the quay, there may be need for additional lanes;
- The space immediately behind the landside rail is used to place the hatch covers and/or to lift special containers (such as flats with bulky or hazardous cargo);
- Finally there is a traffic lane for the SC, the Tractor-Trailer-Unit (TTU), MTS or AGV which commute between the storage yard and the quay. The width depends on the transport system adopted. For SC 2 lanes are usually sufficient, while for AGV's a width equal to that between the crane rails is required.

It is noted that no hinterland connections are allowed on the apron area, contrary to the conventional general cargo terminals, where truck- and rail access onto the quay was customary. For reasons of efficiency and safety this is not common on modern container terminals.

7.4.5 Storage yard

In modern (automated) stacks like the ones at APMT MV2 and Rotterdam World Gateway (RWG), all container types are/can be placed in the same stack. Export containers are preferably placed near the waterside of the stack, import containers at the landside of the stack. Reefers need to be placed at reefer racks, which can also be placed in the same stack. Hazardous cargo can also be placed in the same stack (be it at the side where they can be seen / monitored from outside the stack). Empties are also handled in the same stack.

In older terminals the division can still be seen, and can still be very efficient. The overall storage yard in older terminals is usually divided into separate stacks for export, import, reefers, hazardous cargo and empties. In addition one finds a Container Freight Station (CFS) for the cargo, which is imported in one container, but has different destinations (“stripping”), or which comes from different origins and is loaded into one container for export (“stuffing”). After an import container is stripped and before an export container is stuffed, the cargo is stored in the CFS, which is covered. In some cases the CFS and/or the empty yard is located outside the terminal property.

The surface area requirements for the different stacks (import, export, reefers, empties, etc.) can be calculated as follows:

$$A = \frac{N_c \cdot \bar{t}_d \cdot A_{TEU}}{r_{st} \cdot 365 \cdot m_c} \quad (7.6)$$

A	=	area required (m ²)
N_c	=	number of container visits per year per type of stack in TEU's
\bar{t}_d	=	average dwell time (days)
A_{TEU}	=	required area per TEU inclusive of equipment travelling lanes (m ²)
r_{st}	=	ratio average stacking height over nominal stacking height (0.6 to 0.9)
m_c	=	acceptable occupancy rate (0.65 to 0.70)

The parameter \bar{t}_d (average dwell time) has to be considered separately for import, export and empty containers (for which dwell times are usually much longer). Also, fluctuations in dwell times may have to be considered although it has to be realised that the factor is the average over a great number of containers, thus, generally, will not vary much. \bar{t}_d can be written as:

$$\bar{t}_d = \frac{1}{S(t)_{t=0}} \int_0^{\infty} S(t) dt \quad (7.7)$$

in which:

$S(t)$ = quantity of containers still on terminal divided by total number unloaded containers of 1 call

ECT found that for their home-terminal the following dwell time function applies (see Fig. 7.50):

$$S(t) = \begin{cases} 1 & \text{for } 0 < t < 1 \\ \left(\frac{t_{d,max} - t}{t_{d,max} - 1} \right)^2 & \text{for } 1 < t < t_{d,max} \\ 0 & \text{for } t > t_{d,max} \end{cases}$$

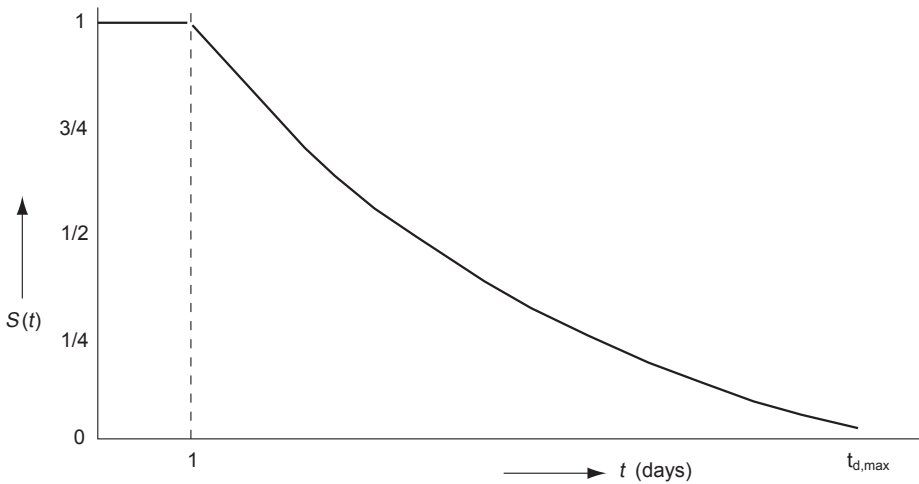

Figure 7.50: Typical dwell time function

From the above it follows that:

$t_{d,max}$ = maximum dwell time
 (e.g. time within which 98% of containers have left the terminal)
 \bar{t}_d = $(t_{d,max} + 2)/3$

$t_{d,max}$ values:

- for Western Europe 10 days

7 Container Terminals

- for developing countries 20-30 days

The factor A_{TEU} is empirical and depends on the handling systems and the nominal stacking height. Typical values are given below in Table 7.5.

Table 7.5: Storage area per TEU for different types of equipment

System	Nominal stacking height	A_{TEU} (m ² /TEU)
Chassis	1	50-65
Straddle carrier	2	15-20
	3	10-13
Gantry crane (RMG / RTG)	2	15-20
	3	10-13
	4	7.5-10
	5	6-8
Forklift Truck (FLT) or	2	35-40
Reach Stacker	3	25-30

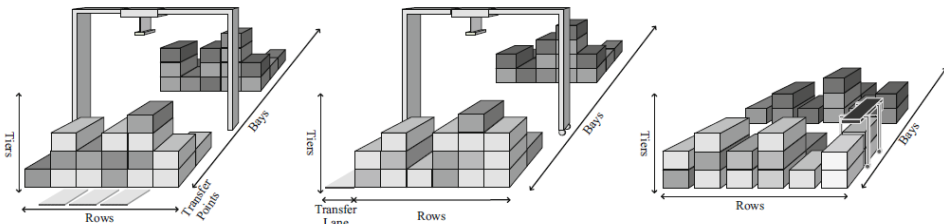

Figure 7.51: Block structures stacking equipment, from left to right RMG, RTG and SC operation (Böse, 2011).

The factor r_{st} in Eq. (7-6) reflects the fact that the sequence in which the containers will leave the stack, is partly unknown (mostly so for the import stack) and that extensive intermediate re-positioning of containers is expensive. Statistically, the need for re-positioning will increase with increasing stack height. Consequently, the value of r_{st} has to decrease. If the acceptable degree of re-positioning can be defined (e.g. 30% additional moves) as well as the degree of uncertainty in departure of containers from the stack, the optimum value of r_{st} can be found through computation or simulation. This degree of uncertainty depends,

inter alia, on the mode of through transport. Rail and IWT can, generally, be programmed quite well, but the sequence of arrival of road vehicles not.

The factor m_c (optimum occupancy rate) has to be introduced because the pattern of arrivals and departures of containers to and from the terminal is stochastic by nature. The optimum value of m_c depends on the frequency distribution of these arrivals and departures, and of the acceptable frequency of occurrence of a saturated stack. The number of container departures per unit of time may be more or less constant, at least for large terminals, but the number of arrivals is not. The container arrival distribution can have different forms and depends, in its turn, on the vessel arrival distribution and on the variation of the number of containers per vessel.

The surface area of the CFS does not follow Eq. (7-6), but is calculated as follows:

$$A_{cfs} = \frac{N_c \cdot V \cdot \bar{t}_d \cdot f_{area} \cdot f_{bulk}}{h_s \cdot m_c \cdot 365} \quad (7.8)$$

in which:

N_c	=	number of TEU moved through CFS (also called "Less Container Loads" or LCL)	[TEU/yr]
V	=	volume of cargo in 1 TEU container ($29 \text{ m}^3 = 90\%$ of 32 m^3 , the volume of a standard size container)	
f_{area}	=	ratio gross area over net area (accounting for internal travel lanes and containers)	[-]
f_{bulk}	=	bulking factor	
h_s	=	average height of cargo in the CFS	[m]
m_c	=	acceptable occupancy rate	[-]

The CFS resembles the transit sheds on the conventional General Cargo terminal. The containers are positioned around the CFS during actual transfer of cargo, which is also reflected in the value of f_{area} (≈ 1.4).

The factor of f_{bulk} is introduced to account for additional space needed for cargo, which needs special treatment or repairs. One finds values of 1.1-1.2.

Finally the factor m_c again reflects the random arrivals and departures of this cargo, and the need to avoid a full CFS. Normal values are 0.6-0.7.

Calculation example

Assume a small terminal to be designed for a capacity of 70,000 TEU/yr of which:

35,000 import (of which 15,000 via CFS)

25,000 export

10,000 empties

Normally, also a part of the export containers passes the CFS, but this is disregarded here. Container handling by straddle carrier, stacking three-high ($A_{TEU} = 13 \text{ m}^2$).

7 Container Terminals

Expected \bar{t}_d values for import, export and empty containers are 10, 7 and 20 days respectively.

Import

$$A_{import} = (35,000 \cdot 10 \cdot 13) / (0.6 \cdot 365 \cdot 0.7) = \text{approx. } 30,000 \text{ m}^2$$

Export

$$A_{export} = (25,000 \cdot 7 \cdot 13) / (0.8 \cdot 365 \cdot 0.7) = \text{approx. } 11,000 \text{ m}^2$$

Empties

$$A_{empties} = (10,000 \cdot 20 \cdot 13) / (0.9 \cdot 365 \cdot 0.8) = \text{approx. } 10,000 \text{ m}^2$$

CFS

$$A_{cfs} = (N_c \cdot V \cdot t_d \cdot f_{area} \cdot f_{bulk}) / (hs \cdot mc \cdot 365) = 15,000 \times 29 \times 5 \times 1.4 \times 1.1 / (2 \times 0.65 \times 365) = \text{approx. } 7,000 \text{ m}^2$$

A possible layout for the above terminal is given in Figure 7-52.

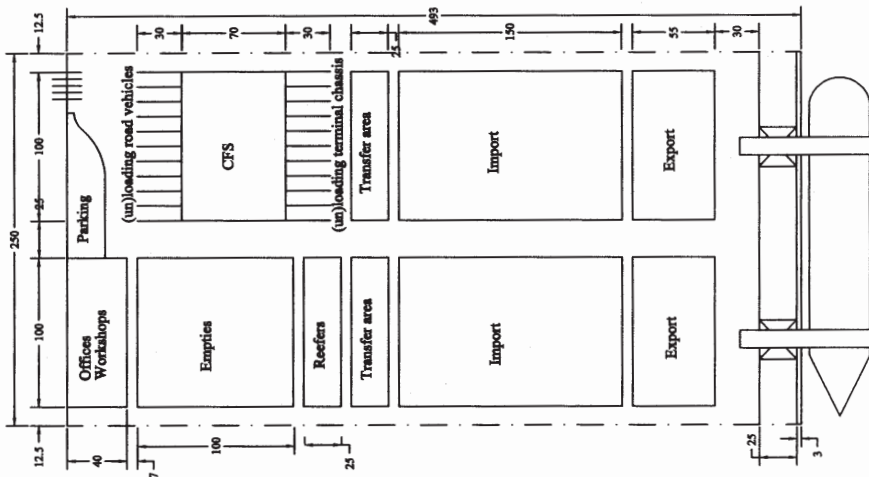

Figure 7.52: Example layout container terminal (UNCTAD, 1985)

Regarding this layout the following comments can be made:

- The export stacks are often located close to the quay in order to expedite the loading process. The containers are preferably positioned in these stacks prior to arrival of the vessel, taking into account their order of loading;
- In addition to the stack areas calculated above there are traffic lanes between the stacks. The 25 m width shown here is rather high;
- On most terminals empties are stacked outside the gate (also because of the long dwell time) and higher than assumed in this example;
- The gate and transfer areas are shown rather schematically. These elements and the

various buildings are dealt with below.

The total gross surface area of this terminal amounts to 11.4 ha. The throughput- area ratio is about 6300 TEU/ha. Compared with this figure the major container terminals in Asia have 2-4 times higher ratios, refer to Table 7.6:

Table 7.6: TEU/ha ratio's

	TEU/ha
Kaohsiung	15,400
Singapore	22,000
Hongkong	40,000 - 50,000 ¹

This difference is to a large extent caused by the efficient use of the storage yard, in particular by lowering the dwell time. To achieve this the stevedoring company must introduce incentives for shorter dwell time and penalties for longer dwell time than average, by applying a variable tariff.

7.4.6 Container transfer area and buildings

The trucks, which bring containers or collect them, enter the terminal through the gate. Here three functions are executed:

- Administrative formalities related to the cargo, including customs inspection and clearance;
- Inspection of the boxes themselves (for possible damage);
- Instruction of the drivers to the location in the container transfer area.

The gate used to create long queues, due to the distinct peaks in the truck arrivals during the day. The introduction of electronic data processing and automated inspection of the boxes has shortened the delays at the gate considerably.

At the container transfer area the trucks take their assigned position. The area is usually located immediately behind the import stacks and the truck's position is chosen to minimise the distance to the import container to be picked up. The export containers are brought straight to the export stacks.

7.4.7 Rail terminal

Transfer to and from rail can done on the terminal itself using on-dock rail terminals. The rail track often runs then parallel to the truck transfer area. An example of such a rail terminal is presented in Fig. 7.53.

¹ Figures include midstream transfer to barges. Therefore these are not comparable.



Figure 7.53: APMT Maasvlakte 2 rail terminal with gantry crane, artist impression (source: APMT)

Off-dock rail terminals are also called Rail Service Centres (RSC). The layout of these RSC's falls outside the scope of this book. Transfer from the container terminal to the RSC is done by trailer, which passes via the gate. On modern terminals an internal road may connect to the RSC, allowing use of terminal equipment such as MTS.

7.4.8 Facilitation of IWT container vessels

Transfer of containers to and from IWT barges is often done along the quays for sea-going vessels. This has two distinct disadvantages however:

- The STS cranes are far too large for handling the small barges, crane production is herefore low;
- The barges often collect their cargo at several terminals, which is time consuming.

The first disadvantage is overcome by creating a separate barge terminal, linked to the main terminal, but having proper equipment. An example of this is found at ECT's Delta Terminal on the Maasvlakte (see also Fig. 7.54), or the EUROMAX terminal. To address both disadvantages it would be better to build a general barge terminal with connections to the different container terminals. This introduces an additional link in the transport process with two times extra handling. The associated extra cost makes this solution unattractive. It is expected that the rapid increase of the number of TEU transported by barge will allow to create multi-user Barge Service Centres (BSC) like the RSC, with internal connections to the surrounding container terminals. However, a BSC requires that all users (container terminal operators) are willing to co-operate.



Figure 7.54: Barge feeder crane at ECT Delta terminal (source: ECT)

7.4.9 Other buildings

Other buildings encountered on the terminal include the office building and the workshop for repair and maintenance of the equipment. The requirements vary per terminal.

7.4.10 Simulation models

Simulation has been applied in container terminals worldwide and allows terminal operators and consultants to accomplish their strategic and tactical planning related to existing and to new container terminals.

Simulation models can be applied for:

- analyse existing terminal operations;
- conceptual design of container terminal extensions and/ or new terminal;
- capacity analysis to determine bottlenecks;
- performance improvement.

7.4.11 Terminal Operating System (TOS)

This paragraph has been derived from PIANC (2014). In order to maximise terminal performance and operational efficiency it will be necessary to install a computerised terminal operating system (TOS). The information from a TOS is used by terminal operators to optimise the use of equipment at the quayside and within the container yard. It can also be

7 Container Terminals

used for managing terminals' business transactions, including gate operations, invoicing, finance, accounting and management reports as well as terminal productivity.

A real time TOS provides up-to-date information on events throughout the terminal and can provide measures of productivity gains, lost time on cranes or in the yard, and can react immediately to any exceptional events.

Using up to the minute information planners can quickly and easily determine the best way to optimise terminal use through yard allocation and vessel loading plans together with optimisation of labour and equipment resources.

The TOS can help eliminate wasted yard space, unnecessary container and equipment moves, lost containers and excessive dwell times. This is achieved through use of a detailed graphic visualisation of the yard equipment activity, vessel stowage and berth space which is monitored in real time with the ability to change options at any time.

The TOS can automatically assign gangs and cranes to vessels, sequence the cranes and track their productivity in real time. It can also predict vessel load and discharge times and can alert the operator to events which might affect service commitments, such as time-sensitive customer delivery or transshipment to another vessel.

The system can usefully generate an automated stow plan and will consider the trade-off between vessel and yard efficiency such as the impact of RMG/RTG crane movements and lane changes and the effects associated with retrievals from more remote parts of the container yard.

TOS system should be capable of offering the following.

Yard Planning and Control can include:

- detailed yard model and real-time views
- utilisation and maintenance reporting
- flexible allocations for yard planning and equipment utilisation
- automated tracking and notification of planning errors

Vessel Planning and Control can include:

- advanced stowage validation
- real time tracking of vessel planning execution
- Last but not least, from the TOS a wealth of very detailed historical data can be obtained by search engines. This data can be most useful for layout and operational rearrangements of the container terminal.

7.4.12 Security

The information in this paragraph has been derived from PIANC (2014).

A new comprehensive security regime came into force in July 2004 with the intention of strengthening maritime security to prevent and suppress acts of terrorism against shipping. Both the International Ship and Port Facility Security (ISPS) Code and the Container Security Initiative (CSI) have represented the culmination of work by the International Maritime Organisation's (IMO) Maritime Safety Committee and the United States Custom and Border Protection Service in the aftermath of terrorist atrocities in the United States in September 2001.

The ISPS Code takes the approach that the security of ships and port facilities is basically a risk management activity and to determine what security measures are appropriate an assessment of risks must be undertaken for each particular case.

Container movements are considered particularly sensitive in this respect, and are therefore subject to some specific regulations. In particular the CSI seeks to use non-intrusive inspection (NII) and radiation detection technology before containers are shipped to the United States of America.

ISPS Code — was adopted by the IMO on the 1st July 2004 as an amendment of the SOLAS [Safety of Life At Sea] Convention. The objectives of the ISPS Code are:

- To establish an international framework involving contracting governments, government agencies, local administrations and the shipping and port industries to detect security threats and take preventive measures against security incidents affecting vessels and port facilities used in international trade;
- To establish the respective roles and responsibilities of the contracting governments, government agencies, local administrations and the shipping and port industries, at the national and international level, for ensuring maritime security;
- To ensure the early and efficient collection and exchange of security-related information;
- To provide a methodology for security assessments so as to have in place plans and procedures to react to changing security levels;
- To ensure confidence that adequate and proportionate maritime security measures are in place.

In order to achieve its objectives the ISPS Code embodies a number of functional requirements. These include but are not limited to the following:

- Gathering and assessing information with respect to security threats and exchanging such information with appropriate contracting governments;
- Requiring the maintenance of communication protocols for vessels and port facilities;
- Preventing unauthorised access to vessels, port facilities and their restricted areas;
- Preventing the introduction of unauthorised weapons, incendiary devices or explosives to vessels or port facilities;
- Providing means for raising the alarm in reaction to security threats or security incidents;
- Requiring vessel and port facility security plans based upon security assessments;
- Requiring training drills and exercises to ensure familiarity with security plans and procedures.

7 Container Terminals

Under CSI, high-risk containers receive security inspections, including X-ray and radiation scans, before being loaded on board vessels destined for the USA. Once high-risk containers are inspected at CSI ports, they are not ordinarily inspected again upon arrival at the US seaport. This means that the containers inspected at CSI ports actually move faster, more predictably and efficiently through USA seaports.



Figure 7.55: Nuctech Fast Scan Vehicle and Container inspection system
(source: <http://www.nuctech.com>)

7.5 References

- Bartosek, A., Marek, O., Quay Cranes in Container Terminals, Transaction on Transport Sciences, Volume 6, 2013
- Bichou, K, Port operations, planning and logistics, Lloyd's practical shipping guides, 2009
- Böse, J.W (Ed.), Handbook of Terminal Planning, Springer, 2011
- Cargo systems, Opportunities for container ports, IIR Publications Ltd, London, 1998
- Containerisation International, Yearbook, 2005
- Frankel, E.G. , Port planning and development, Wiley Interscience, New York, 1987
- Groenveld, R., Service Systems in Ports and Waterways, Delft Academic Press, 2001
- Levinson, The Box: How the Shipping Container Made the World Smaller and the World Economy Bigger, 2008
- Midoro, R., Musso, E. and Parola, F., Maritime liner shipping and the stevedoring industry: market structure and competition strategies, Maritime Policy & Management, 2006
- Penfold, A., Changes in Shipping Industry, Proc. Seminar on Life Cycle Approach in Port Infrastructure, PIANC, Brussels, 2005
- PIANC, Guideline for the design of fender systems, Brussels, 2002
- PIANC, Report 135, Design Principles for Small and Medium Marine Container Terminals, Brussels, 2014

- Rademaker, W.C.A, Container Terminal Automation, Feasibility of terminal automation for mid-sized terminals. M.Sc. thesis, Delft University of Technology, 2007
- Royal Institute of Naval Architects, Significant Ships 2013, United Kingdom, 2013
- Thoresen C. A., Port Designers Handbook, Thomas Telford, 2010
- UNCTAD, Port Development, a handbook for planners in developing countries, Geneva, 1985
- Van Beemen, J., Container Terminal Planning Course, Royal HaskoningDHV, 2008
- Veldman, S., On the ongoing increase of containership size, Ecorys, 2011

Chapter 8

General Cargo and Multipurpose Terminals

8.1 Introduction

In previous chapters reference is made to General Cargo terminals (further referred to as GC terminals) as the traditional port area for transfer and storage of commercial goods. In the classification of terminals according to the form in which the cargo is transported (see Chapter 2), this terminal falls under "Other". In Section 6.4 the shift from general cargo to containerised transport is explained. Although the latter trade has surpassed the former in terms of tonnes of cargo and will continue to grow fast, the GC terminal will maintain its function for specific commodities, such as neo-bulk (steel products, non-ferro products, forest products, etc.) and in certain conditions (small ports, with yet insufficient throughput for a dedicated container terminal). Quite often one sees cars being handled at GC terminals. However for the specific details of that trade one is referred to Ch.9.

For all Dutch ports the handling of general cargo amounted in 1998 5% of the total throughput. In Vlissingen/Terneuzen (Zeeland Seaports) this percentage was 13% in the same year and growing faster than any of the other forms of cargo.

An interesting development is the *all-weather terminal*, that provides a covered dock for loading and unloading of products such as steel and paper. The improved quality and increased operability of such terminals is attractive for shippers and forwarders, as demonstrated by the success of the Waterland Terminal in Amsterdam (see Figure 8.1).

Multipurpose terminals are treated in the same chapter because they are often developed from GC terminals, as described in Section 6.4.



Figure 8.1 All-weather terminal in Amsterdam

In summary: firstly there is a need for modern GC terminals and secondly existing terminals are often insufficient in terms of land area and quay design. Modernisation of existing terminals is therefore an additional challenge to the port planner.

The type and size of ships are described in Chapter 2. We are dealing with general cargo and multipurpose ships in the range of 5,000 to 25,000 dwt, with draughts ranging from 7.5 to 10 m and lengths ranging from 100 to 170 m (see Figure 2.34).

8.2 Non-containerised General Cargo

8.2.1 Types of General Cargo

As mentioned above GC includes a wide range of different commodities, some of which may in some ports be handled at separate terminals.

Within the NSTR main groups of commodities (see Chapter 2), we find the following types of general cargo and their specific way of being packaged/handled:

Table 8.1 Types of General cargo

	Main Group	GC commodities	Packaging / handling
0	Agro products	(sawn) timber paper	Pre-slung Rolls in cassettes
1	Food products	Fruit condensate Sugar Wine, etc.	Special containers Bags ¹ Special containers
3	Oil, oil products	Lubricating oil	Drums
5	Iron, steel, etc	Steel profiles Steel plates	Pre-slung Rolls
6	Raw minerals etc	Cement	Bags on pallets
7	Fertilisers	Phosphate	Bags on pallets
8	Chemical products	Resins	Bags
9	Vehicles etc	Machine (parts)	Crates

The above list is by no means exhaustive, it aims to demonstrate the great variety of cargo passing through GC terminals. Although some specialisation is noticeable (e.g. Forest Terminals in Rotterdam handling only forest products), the majority of GC terminals handles a wide range. This is possible because the type of equipment for loading and unloading is common: mobile cranes with a capacity of 20-30 tonne, which can handle almost any of the abovementioned types of cargo (see next section). However, in some cases specific storage requirements have to be fulfilled, such as:

- Fruit condensate requires refrigerated warehouses
- Chemical products, if hazardous cargo, require safety precautions

¹There is a trend to transport bagged sugar in containers, instead of on pallets

These special cases are not elaborated in this Chapter; reference is made to Chapter 12 on Fisheries Ports on refrigerated storage and the Chapter 10 on Liquid Bulk Terminals for safety requirements.

8.2.2 Terminal Logistics

A general flow scheme is shown in Figure 8.2. The option of direct transfer of cargo from and to the ship is still indicated, but rare since the (un)loading capacities exceed the rate at which goods can be removed or delivered. Normally the cargo is transported by terminal equipment (e.g. forklift trucks) to either the transit shed or the open storage, depending on size and whether it needs protection or not. From there it is taken to its destination, *the consignee*, by different modes of transport. Only when cargo is stored at the terminal for an extended period of time it is stored in the warehouse. The same conditions apply to export cargo.

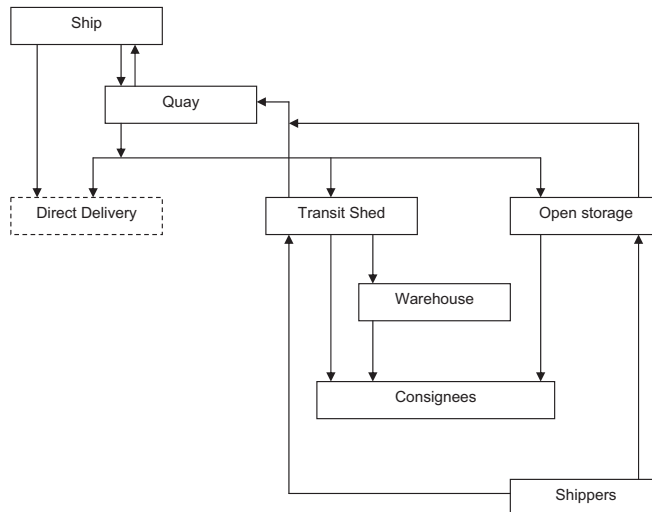

Figure 8.2 Cargo Flow Scheme

Ship-Quay

In most cases the transport of cargo between the ship and the quay is achieved by the ships derricks. Rail-mounted luffing cranes, such as were used in older ports, do not give a higher productivity and require stronger quays. A small number of mobile cranes on pneumatic tyres will be needed to lift the heavy items, including containers. Normally they will be needed for only a fraction of the ship working time and therefore two per berth will be sufficient.

Labour is needed in the holds and at the quay for hooking up and unhooking of the cargo. It is customary to have one gang per hold, the size of which may vary for different types of cargo. With 3 holds being worked at the same time, 3 gangs are working simultaneously. For small coastal vessels 1-2 gangs may be sufficient.

Unloading and loading rates depend on the type of cargo, the number of gangs, etc. The basic parameter is the average productivity of a gang:

	<i>t / hr</i>
Conventional general cargo (breakbulk)	8.5 - 12.5
Timber and timber products	12.5 - 25
Steel products	20 - 40
Containerised cargo	30 - 55

Quay-Transit shed / storage

The transit sheds are placed next to the quay and goods are normally transported by *forklift trucks* (FLT). Per gang at the quay 3 FLT's will be needed. When cargo goes directly to the open storage area this can be done by the FLT's as long as the travelling distance is within 100 m. For longer travelling distance a combination of FLT and tractor + trailer becomes attractive. The FLT's are then used to load and unload the trailers. Per hold 2 FLT's, 2 tractors and about 8 trailers will be needed to match the quayside productivity.

In the storage itself 1 or 2 mobile cranes plus a number of FLT's will be required for handling.

Hinterland connections

As mentioned railway lines are no longer installed on the quay and also trucks are not commonly given direct access to the quay. If there is a railway connection, it is usually located at the rear side of the terminal.

Trucks are allowed inside the storage area, with internal roads giving access to the transit shed and warehouses, and to the open storage.

Where hinterland transport is carried out by barges, these are normally handled at the quays for seagoing vessels.

8.3 Number of Berths and Quay Length

To determine the quay length first of all the number of berths has to be established. As in the case of container terminals this can be done less or more accurate depending on the stage of the planning process.

In an early stage of planning a rough estimate is made using the following approach. The throughput of a GC berth is calculated from the average productivity of a gang, the number of gangs and the number of effective working hours in a year.

$$c_b = P \cdot N_{gs} \cdot n_{hy} \cdot m_b \quad (8.1)$$

in which

- c_b = throughput per berth [t/yr]
- P = average gang productivity [t/hr]
- N_{gs} = number of gangs per ship [-]
- n_{hy} = number of operational hours per year [-]

8 General Cargo and Multipurpose Terminals

m_b = berth occupancy rate [-]

In the previous section typical values of P are given for conventional general cargo, neo-bulk and containerised cargo, handled at a GC terminal. The mix of cargo types for a new terminal, as defined in the transport forecasts, is translated into a weighed value of gang productivity.

The number of gangs per ship depends on the size of the ship as explained in Section 8.2. Again a weighted average of N_{gs} has to be used, taking into account the mix of small and medium size vessels calling at the future terminal.

The number of operating hours depends on the number of shifts considered. For a two- shift operation the full 16 hours are used in calculating the n_{hy} , notwithstanding the fact that there will be loss of time between shifts. The gang productivity P is a net productivity measured as an average over the 8 hours shift period.

Let us consider a terminal for breakbulk cargo and timber products in a ratio of 3 to 1. The gang productivity amounts to 12.5 t/hr. The ship sizes range from 100-150 m which implies an average of 2.5 gang/ship. With 2 shifts per day, 6 days per week n_{hy} becomes 4992 hours. An average berth productivity of 109,000 t/yr is found for a occupancy rate of 0.7. This rate is quite high, but not uncommon for GC terminals, where ship waiting time is more easily accepted.

Then the number of berths is determined (while neglecting the time for berthing and de-berthing):

$$n = \frac{C}{c_b} \quad (8.2)$$

where C is the required throughput across the terminal in t/yr.

Service time of GC ships

For a 15,000 dwt GC vessel we assume that 3,000 tonnes is unloaded in a specific port and 1,500 tonnes is taken on board. 3 gangs handle the total of 4,500 tonnes of cargo with a productivity of 15 tonnes per hour (most of the cargo is conventional breakbulk and timber). Upon arrival 1 hour is spent on berthing and unfastening the lashings before the actual unloading process starts.

The total time for unloading and loading amounts to 100 hours. For a two shift operation this means 6.25 days. Even when the terminal would provide a 24 hour service the service time is in excess of 4 days.

These numbers are typical for the GC trade and demonstrate the difference with the container trade: several days in port are quite common and a few hours delay for whatever reason (waiting time, berthing, hatches, crane repair, etc.) is much less of a problem.

The more accurate method for determining quay length is based on the expected number of calls N_{sy} per year and the average volume of cargo unloaded and loaded per call, c_c in tonnes. From the values of c_c , P and N_{sy} the average service time is determined. By applying queuing theory the number of berths and corresponding average waiting time is calculated, assuming a certain distribution of the inter-arrival times. For the selection of the distribution function and the numerical tables used in the calculation reference is again made to Groenveld, (see Section 4.6).

It is possible that 2 or more different commodities are handled at the GC terminal, each having quite different characteristics in terms of ship size and gang productivity. In this case we prefer to execute the calculations for the average values per commodity, thus arriving at separate numbers of berths.

Quay length

Once the number of berths is found the quay length is again calculated by means of the same equation used for container terminals (see Section 7.4.3, Eq. (7.5)).

$$L_q = \begin{cases} L_{s,max} + 2 \cdot 15 & \text{for } n=1 \\ 1.1 \cdot n \cdot (\bar{L}_s + 15) + 15 & \text{for } n>1 \end{cases} \quad (8.3)$$

8.4 Storage Area and Overall Terminal Lay-out

The area required for the separate storage facilities (transit shed, open storage, warehouse) has to be determined from the annual throughput and the average transit time (or dwell time) of the goods as main parameters. For instance for a *transit shed*, the required floor area A_{gr} can be calculated as follows:

$$A_{gr} = \frac{f_{area} \cdot f_{bulk} \cdot N_c \cdot \bar{t}_d}{m_c \cdot h_s \cdot \rho_{cargo} \cdot 365} \quad (8.4)$$

in which:

N_c	=	total annual throughput which passes the transit shed
\bar{t}_d	=	average dwell time of the cargo in days
ρ_{cargo}	=	average relative density of the cargo as stowed in the ship (e.g. 0.6)
h_s	=	average stacking height in the storage (e.g. 2 m)
f_{area}	=	ratio gross over net surface, accounting for traffic lanes for FLT's etc. (e.g. 1.5)
f_{bulk}	=	bulking factor due to stripping and separately stacking of special consignments, damaged goods, etc.
m_c	=	average rate of occupancy of the transit shed or storage

Example

For

N_c	=	120,000 t/yr
f_{area}	=	1.5
f_{bulk}	=	1.2
\bar{t}_d	=	10 days
m_c	=	0.7
h_s	=	2 m
ρ_{cargo}	=	0.6 t/m ³

the required surface area A_{gr} will be 7200 m², e.g. a shed of 60 · 125 m.

m_c has to be determined in such a way, that most of the fluctuations in \bar{t}_d and in the cargo flows per unit of time can be absorbed.

The factor m_c , consequently, clearly depends upon the number of berths. The optimum value depends also strongly on the possibility of occasionally storing excess cargo outside the terminal and the extra costs thereof.

If statistical material is available, an optimisation can be made by means of the probability distributions of the relevant parameters. This is, however, rarely the case. For that reason, m_c is usually arbitrary chosen in the 0.65 to 0.75 range.

In case clear seasonal fluctuations in the cargo flows occur, the required storage area has to be calculated on basis of the peak season figures instead of the annual throughput.

For determining area requirements for open storage and warehouses, an identical procedure can be followed, the value of the parameters may differ though.

Terminal lay-out

A typical lay-out for a modern GC terminal is given in Figure 8.3 (UNCTAD, 1985). The following observations can be made:

- iv. The berth length of 160 m implies that the terminal is designed for an average ship length of 130 m, corresponding with 10,000 t. But a 25,000 dwt vessel with $L_s = 170$ m can also be accommodated when the adjacent berth is not occupied.
- v. Three transit sheds of 9,100 m² surface area each are placed close to the quay.
- vi. The width of the central delivery zone of 45 m is determined by the need of long trucks to move into and out of loading bays along the transit sheds and the warehouse (see also Figure 8.4). If a large number of 15 meter long trucks were used for delivery the delivery zone would have to be up to 50 m width. A one-way road circuit improves the safety and the capacity of the terminal.

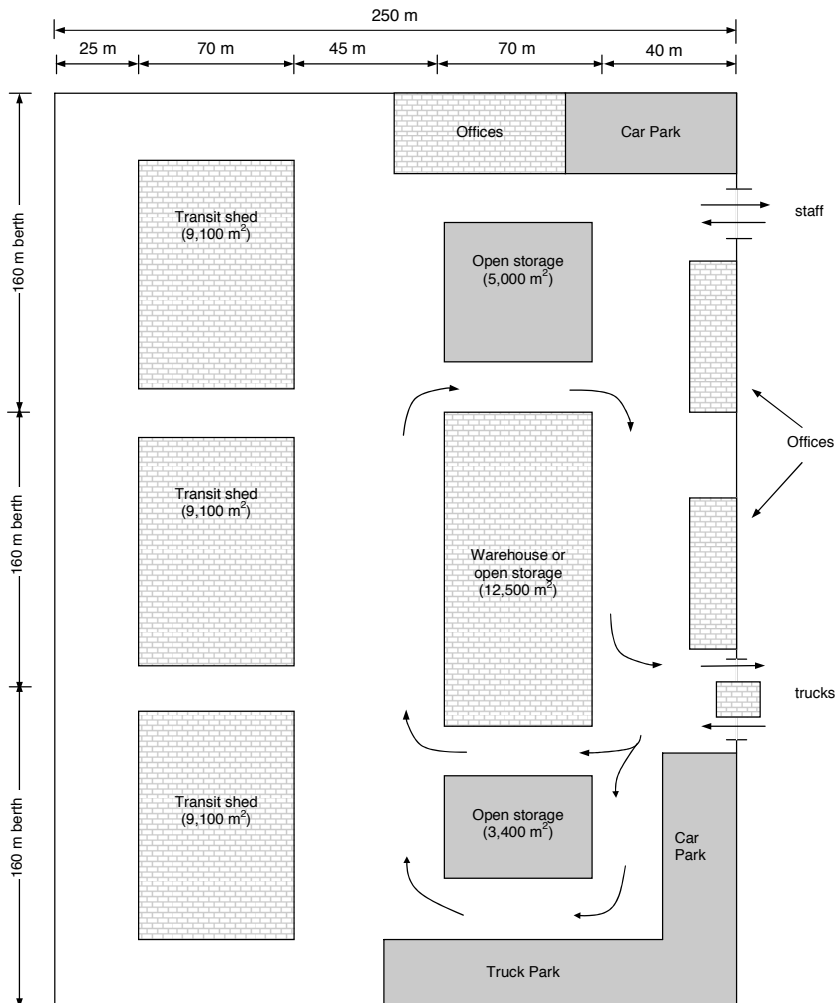

Figure 8.3 Typical modern three-berth breakbulk zone

- vii. The warehouse is only needed when the terminal operator wishes to provide long- term storage of cargo, for example for cargo that must be aged or cargo which is to be sorted, packaged and sold from the warehouse (i.e. a forerunner of the districenter).
- viii. There should be sufficient space for offices (both for the terminal management and for shipping agents) and for parking of trucks and private cars.

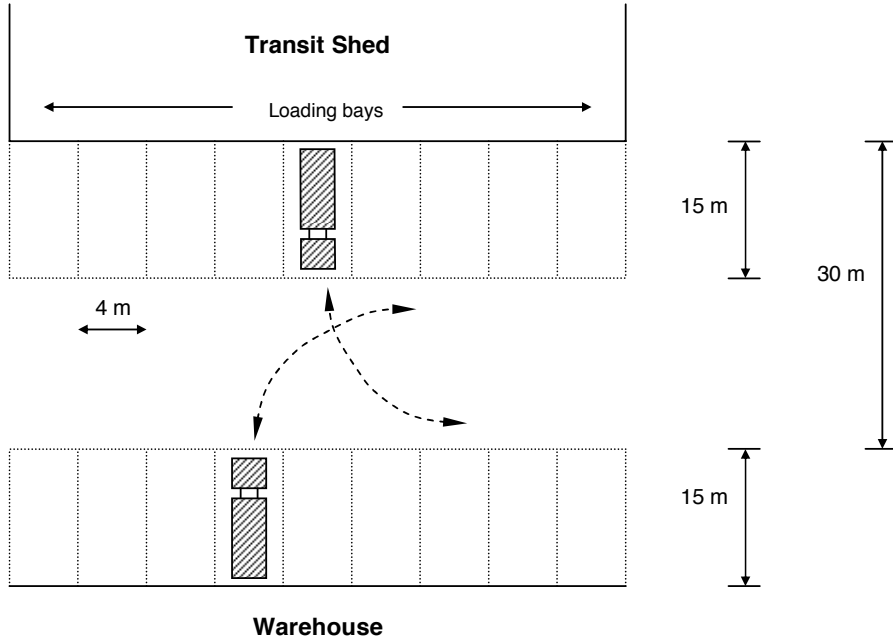

Figure 8.4 Necessary space for trucks

8.5 Multipurpose Terminals

The multipurpose terminal becomes necessary when GC ships calling at the port start to carry a substantial volume of cargo in containers. Once the change-over has been made the terminal will be able to service a mix of GC and smaller container ships.

The terminal layout shown in Figure 8.3 is not suitable for receiving containers on a regular basis for two reasons:

- i. Containers need open storage, preferably close to the quay
- ii. The apron width is too narrow for handling of containers

Conversion of this terminal to a multipurpose terminal could lead to a lay-out as shown in Figure 8.5. Two transit sheds and the warehouse have been broken down to provide space for the container storage yard.

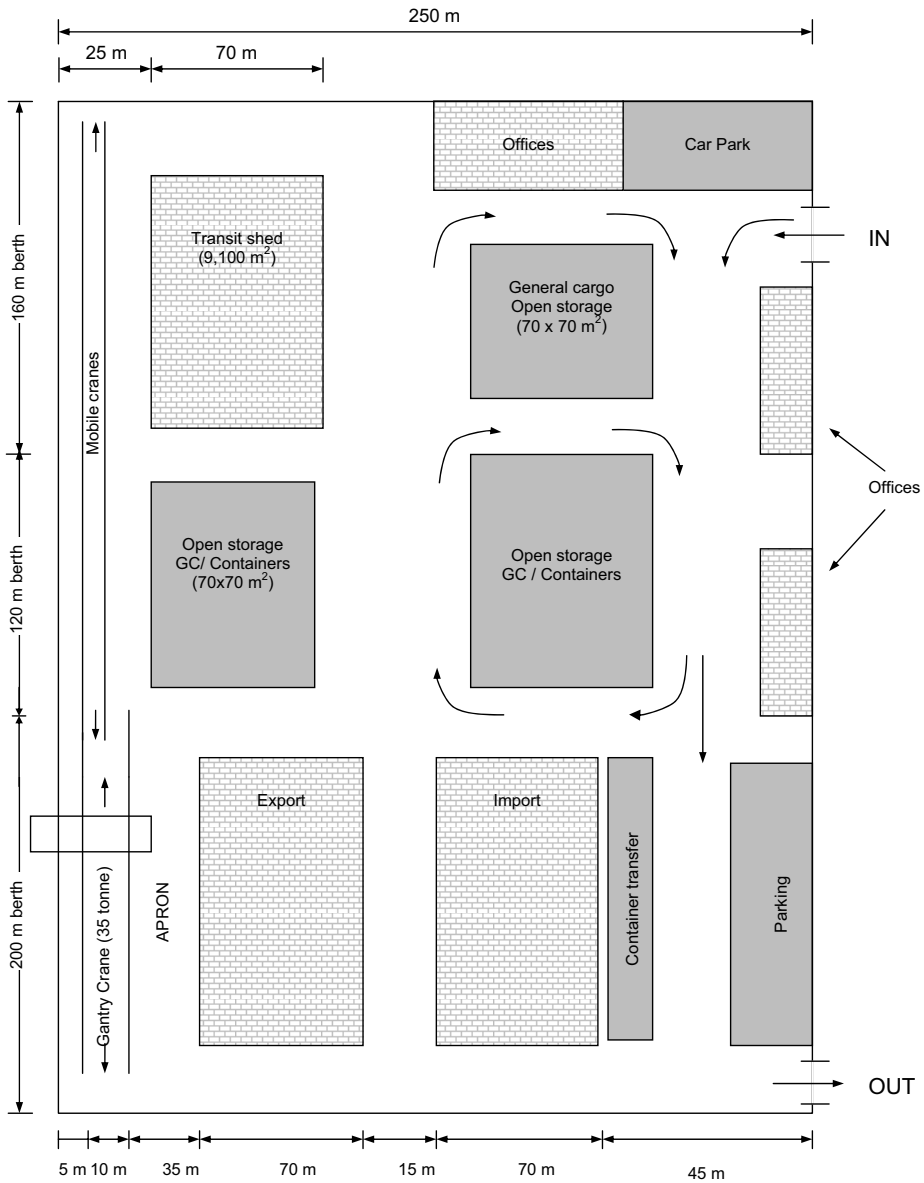

Figure 8.5 Multipurpose terminal

Features of this layout are:

- i. About 200 m of quay has been converted for container handling, sufficient for multi-purpose ships of 25,000 tonnes and small container vessels. The maximum draught at the quay is not increased, since this might endanger the stability of the existing quay wall.
- ii. Along this stretch of quay a rail mounted gantry crane is installed, capable of handling the heavier boxes and providing a higher productivity than the mobile cranes. The mobile cranes can still operate along this part of the quay at other holds.

8 General Cargo and Multipurpose Terminals

- iii. The apron area is widened, allowing straddle carriers or reach stackers to operate between the quay and the stacks.
- iv. The detailed layout of the container storage area depends on the chosen type of equipment. There are separate areas for import and export containers, while some of the open storage for GC may be used for off-size containers. The transit shed can be utilised as CFS for "stripping and stuffing" of containers.
- v. In order to guarantee the traffic safety at the terminal, the one-way circulation has been maintained by separating the entrance and exit gates. Other solutions are possible, but lead to more complex situations.

It is stressed that this layout is only one possible alternative, within the confined space of the existing CG terminal. When planning an entirely new multipurpose terminal more depth of land is desirable. Moreover one would likely design for larger container vessels, i.e. 2nd or 3rd generation, with lengths up to 275 m and a draught of 11 m. This would make the terminal better suited for growth of the container throughput.

8.6 References

UNCTAD, Port Development, United Nations, New York, 1985

Chapter 9

Ro/Ro and Ferry Terminals

9.1 Introduction

As explained earlier in Chapters 2 and 6 the term Roll-on/Roll-off applies to a specific category of cargo transport, whereby the road-trailers are driven on and off the ship. The following types of Ro/Ro transport can be distinguished, depending on vessel size and sailing distance:

Ro/Ro ferries Developed from the traditional ferries, with travel times ranging from a few hours up to a day. Combination with passenger transport, including passenger cars and buses. Regular service, of which the frequency depends on the traffic volume. Typical examples are the ferry lines between the UK and the European continent, and between Italian ports and the islands in the Mediterranean Sea.

Ro/Ro ships Dedicated cargo ships (hence no passenger facilities), long sailing distances. In recent years this type of service is developed on short-sea routes, e.g. from Scandinavia to West-Europe, and from there to the Iberian peninsula. But also intercontinental lines employ Ro/Ro ships, when they service ports with inadequate container handling facilities.

Ro/Ro container ships Combination of Ro/Ro and Lo/Lo (see also Section 2.3.4). The total volume of Ro/Ro transport is growing at about the same rate as container transport. The size and capacity of the vessels is also growing, but at a more modest rate compared with container ships (see also Chapters 2, 3 and 4). When comparing the two alternatives it becomes clear that each has its specific areas of economic advantage:

- vi. Ro/Ro transport provides a fast and seamless connection for "continental containers", as the road trailers are often called. No transfer of goods needed and no dwell time in a storage yard, such as for containers.
- vii. The trailers are driven on and off the ship one by one and require more space per unit than a container. The total cost per tonne cargo exceeds that for container cargo. This cost difference outweighs the above mentioned advantage of Ro/Ro transport, when the sailing distance and volumes of cargo grow. The precise turning point depends on a number of economic factors.

A special type of Ro/Ro vessel is the car-carrier, transporting automobiles from a factory to other countries. Although the trade is entirely different from the transport of general cargo by Ro/Ro vessels, the common aspect is the use of ramps for (un)loading.

9.2 Lay-out Ro/Ro and Ferry Terminals

Common elements in the lay-out of terminals for ferries and Ro/Ro ships are the following:

- The (un)loading of trailers is concentrated in one location, usually at the stern or the bow of the vessel. This determines the quay-configuration.
- The maximum number of trailers (and other vehicles in case of a ferry) that can be taken on board, must be parked in an orderly manner, close to the loading point. But the unloaded trailers also need parking space, when these are handled by terminal tractors. The total surface area for parking may be as large as twice the area needed for a full ship load.

There are also differences between ferry and Ro/Ro terminals:

- Minimisation of the *service time* is for a ferry even more important than for a Ro/Ro ship, in view of the relatively short sailing time of the ferry and tight schedules. For this reason a ferry berth is often designed in a special way to reduce berthing time, whereas the berth of a Ro/Ro vessel is comparable with GC and container vessels.
- *Ferry terminals* need passenger facilities, including a terminal building and separate access bridges to the ship.

Another important difference is caused by the fact that a ferry line owns and operates the terminals at both sides, whereas Ro/Ro shipping lines call at a number of ports during one journey, where the terminal is operated by the port or a separate company. This is reflected in the planning of the terminal lay-out as follows:

- A ferry link must be developed integrally, including number of vessels, sailing time and berthing time. Hence, the number of berths is determined as a part of the overall system.
- A Ro/Ro terminal must provide adequate service to the ships, that usually belong to various shipping lines. The situation is comparable to GC and container terminals: the number of berths depends on the requirement to limit or avoid waiting times. Like for general cargo and container terminals, the (un)loading capacity must be determined in order to estimate the average service time.

Because of the above mentioned differences the two types of terminals are treated now separately.

9.2.1 Ferry Terminal

Berthing Facilities

The number of berths depends on the number of vessels to be handled simultaneously. As mentioned before, per vessel the (un)loading is taking place across a ramp, connecting the vessel with the landing area. The berth further provides for mooring dolphins and a fen-

dering system, that allow rapid berthing and unberthing and only little movement of the vessel during (un)loading. When the terminal is located in relatively calm water a *berth lay-out* such as shown in Figure 9.1 may suffice: the vessel is positioned against a fendering system on one side, with the stern fenders on both sides of the landing area. Mooring lines fore and aft hold the vessel in position.

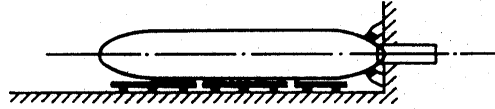

Figure 9.1 Corner berth lay-out

When on the other hand the ferry location is exposed to waves and/or current, a more enclosed berth is needed as shown in Figure 9.2. Such wedge type lay-outs are quite typical for ferry berths. The heavy fendering on both sides allows a rather high approach velocity and guides the ship to the correct position at the landing area, at the same time reducing its speed by friction. To avoid damage of the ship hull these type of ferries are provided with a belting all around, i.e. a strengthened girder at the level of one of the decks. The design of the landing area depends on various factors and will be treated in Section 9.3.

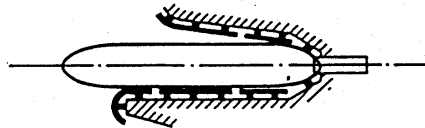

Figure 9.2 Wedge type ferry berth

Roads and parking area

The terminal area has to facilitate a smooth flow of vehicles in both directions, including sufficient parking area. While the actual lay-out will depend on the number of berths, the capacity of the ferries and the geometrical conditions of the available land area, a typical example of a ferry terminal is given in Figure 9.3. The main streams of cars and trucks, outbound and inbound, are indicated and are shown to be fully separated.

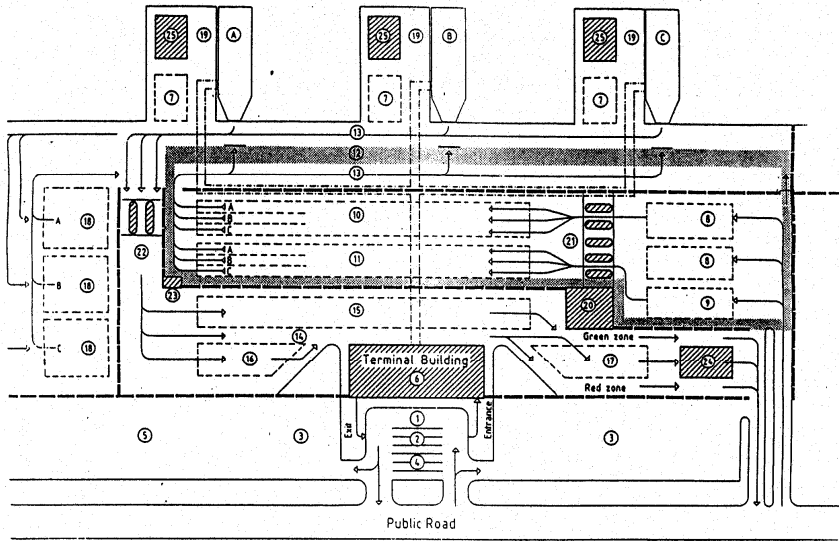

Figure 9.3 Typical ferry terminal (source: PIANC, 1995)

Terminal building

A building with passenger facilities is needed at the terminal, e.g. for buying tickets, to provide a waiting lounge, cafeteria and/or restaurant, and possibly some shops. Embarking and disembarking of passengers should be separated from the (un)loading of vehicles and preferably via a direct bridge connection between the terminal building and the vessel.

9.2.2 Ro/Ro Terminals

Berthing facilities

For vessels with quarter or side ramps any quay will serve, provided it is long enough and there are no obstacles, such as bollards, at close spacing (see Section 6.4). Vessels with stern ramps however, need a separate landing area, which can either be fixed or floating (see Figure 9.4). The *fixed landing area* is often combined with other quay/terminal facilities, such as a multipurpose terminal or a combined container and Ro/Ro terminal. A fixed or floating platform (often referred to as *link span*) is a flexible solution in existing ports, where a Ro/Ro terminal is added. This will be treated in more detail in Section 9.3.

The length of a single berth follows the rules given in Chapter 7; i.e. the largest ship determines the required space. For a multiberth facility the total quay length would be determined with Equation (7.5), provided that all vessels have quarter or side ramps.

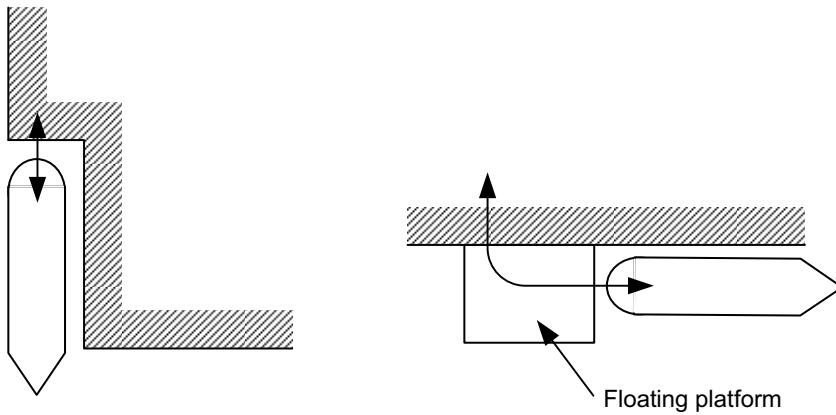

Figure 9.4 Fixed and floating landing areas

The number of berths can also be estimated using an approach like for container terminals given in Equations (7.2) and (7.3), in which the (un)loading capacity is given in trailer units per hour.

Parking area

The parking area at a Ro/Ro terminal is a function of the number of vehicle movements per year, the average transit time in days and the area requirement per vehicle. Additional space for access roads and reserve capacity in view of peak loads needs to be taken into account. In UNCTAD (1985) a planning chart is given. For an average transit time of 2 days (which is high for modern Ro/Ro terminals) and an area requirement of 40 m² per trailer unit, the parking area amounts to 1 ha per 25,000 vehicle movements per year (inbound and outbound).

9.3 Special Design Aspects

9.3.1 Ramp and Bridges

Ro/Ro ships and ferries are equipped with at least one ramp. At sea the elevated ramp closes off the opening in the ship hull, at the berth the ramp is lowered and gives access to and from the landing area. Depending on the vessel size, the tidal variation at the berth and the difference in elevation of the fully loaded and the unloaded vessel, different arrangements of the landing area are needed to allow uninterrupted (un)loading.

Maximum tidal variation < 1.5 m Under this condition a fixed landing area is feasible. Its design should accommodate the ship ramp in all tidal conditions, given its *maximum allowable slope* of 1:8. To account for ship size two classes have been adopted internationally (see Figure 9.5):

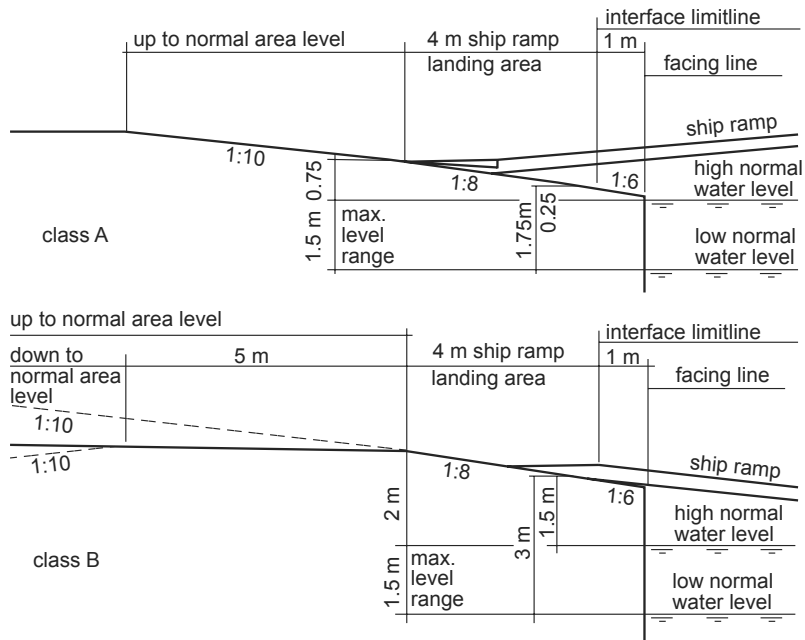

Figure 9.5 Elevation of landing area and ship ramp

- Class A: ships with a ramp, which reaches in loaded condition between 0.25 m and 1.75 m above water level.
- Class B: ships with a ramp, which reaches in loaded condition between 1.5 m and 3.0 m above water level.

As shown in Figure 9.5 the landing area itself is often sloping down towards the waterfront, with a slope 1:8 for the ship ramp landing area.

Tidal range > 1.5 m In this case a *bridge system* is needed between the ship ramp and the landside. Various concepts are in use, again depending on local conditions.

- Bridge, hinged at land side and floating at ship side (Figure 9.6). The bridge moves up and down with the tide and therefore does not consume manpower or energy. Depending on the response characteristics of the bridge, it may be sensitive to waves, and in a different mode than the ship. When the two floating bodies move out of phase the (un)loading is severely hampered. Another limitation of this concept is that it can not accommodate large differences in draught of the vessel.
- Bridge hinged at land side and mechanically adjustable in height at the ship side (Figure 9.7). In many of the ferry terminals on both sides of the Channel, e.g. in Oostende and Dover, these type of bridges are the common solution. As shown in Figure 9.7 in Dover two bridges and a passenger walkway are moved by winches up and down with the tidal variation. The system is quite expensive, compared with the following concept.

9 Ro/Ro and Ferry Terminals

- A fixed or floating pontoon, located along the quay. This type, commonly referred to as *link span*, offers great flexibility at relative low cost. The pontoon can be relocated to other locations inside the port or in another port (see Figure 9.8).

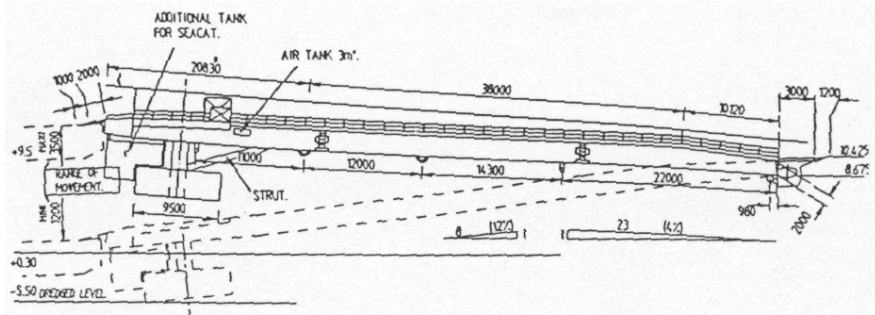

Figure 9.6 Bridge hinged at land side and floating on ship side

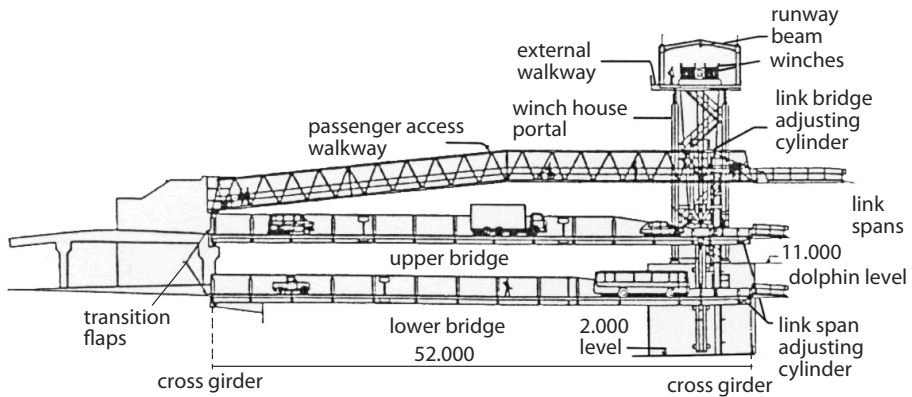

Figure 9.7 Bridge hinged at land side and mechanically adjustable in height at the ship side

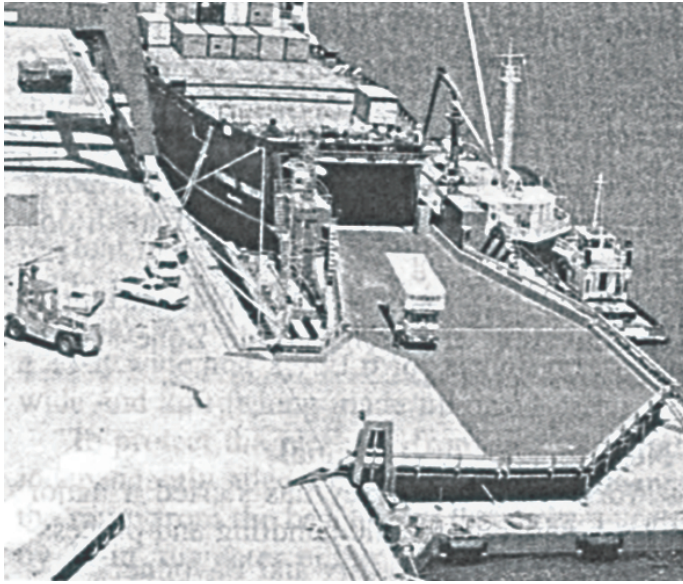

Figure 9.8 Floating linkspan in Melbourne, Australia

9.3.2 Bottom Protection

The effect of the propeller jet velocities on the bed material along a berth leads to erosion in case of non-cohesive sediments without protection. At Ro/Ro and Ferry berths this effect is even more pronounced, due to the high power of these ships and the way this motor power is employed at departure. In the 1980s several Ro/Ro terminals in Western Europe showed damage to the bottom protection, leading to erosion pits along the berths and risk of instability of the quay structures (Verheij et al, 1987). To design a stable bottom protection an empirical formula is used, as follows:

$$d_{50} \geq \frac{1.3 \cdot u_b^2}{g \cdot \Delta} \quad (9.1)$$

in which:

d_{50}	=	characteristic diameter bottom protection	[m]
u_b	=	velocity near the bed	[m/s]
Δ	=	relative density of stone protection	[-]

The coefficient 1.3 is considerably higher than that for the corresponding formula for natural flow, due to the effects of high turbulence and the vicinity of quay-walls (e.g. in case of a corner berth).

The velocity in the propeller jet can be calculated for the case without too much side and bottom effects by means of formulae developed by Fuehrer (1987). In practice these effects

are often present, leading to increased velocities which are difficult to predict and require application of 3D numerical flow models.

With the growth of ship size also the installed power increases. This has created a situation where a rip-rap protection is not a suitable solution anymore, because the d_{50} of the stones becomes too large and a considerable thickness of stone filter is needed to prevent erosion of the underlying sand. In these cases several new methods of bottom protection have been introduced and applied at ferry berths:

- Concrete mattress, which is a fabric filled with underwater concrete.
- Concrete blocks, interconnected by wires to form a mattress, placed by a special vessel on a geomembrane.

9.4 References

Bruun, P., Port Engineering, Gulf Publication Company, 1989

Fuehrer, M., H. Pohl and K. Romisch: Propeller jet erosion and stability criteria for bottom protections of various constructions, PIANC Bulletin no 58, 1987

PIANC, Report on Standardisation of Ro/Ro Ships and Berths, Supplement to Bulletin No.33, Brussels, 1979

PIANC, Port Facilities for Ferries, Report of WG PTCII-11, Brussels, 1995 UNCTAD, Port Development, United Nations, 1985

Verheij, H.J., T. Blokland, M.P. Bogaerts, D. Volger, and R.W.L. van der Weijde: Experiences in the Netherlands with quay structures subjected to velocities created by bow thrusters and main propellers of mooring and unmooring ships, PIANC Bulletin no 58, 1987

Chapter 10

Liquid Bulk Terminals

10.1 Introduction

Liquid bulk comprises the following commodities: crude oil, oil products, chemical products, liquefied gases and vegetable oils. Oil and gas terminals are separately classified in ports, since:

- The goods are mostly classified as 'hazardous', leading to special safety requirements.
- Loading and unloading occur through one central manifold on the ship, placed more or less midships. As a result, (un)loading equipment does not have to be able to move alongside the ship to service the different holds, and, thus, no full-length marginal quay is required. For carrying the (un)loading arms and auxiliary equipment, a relatively small platform is generally sufficient.

Consequently, there are striking differences with regard to dimensions and nature of the port facilities required as compared to other trades.

10.2 Oil Tankers and Gas Carriers

10.2.1 Oil Tankers

The transport of crude oil generally happens in large tankers (VLCC's) of 200,000 t or more. Refined products are transported by product tankers of up to 100,000 t. Typical tanker dimensions are given in Table 10.1.

Table 10.1 Dimensions of oil tankers

DWT [t]	water displacement [t]	length L_{oa} [m]	width [m]	fully loaded draught [m]	fully loaded freeboard [m]
20,000	26,000	175	21.4	9.2	2.9
50,000	65,000	230	31.1	11.6	3.7
70,000	87,000	245	35.4	12.8	4.0
100,000	125,000	272	39.7	14.6	4.6
150,000	185,000	297	44.2	17.1	5.5
200,000	240,000	315	48.8	18.9	6.4
250,000	295,000	338	51.8	20.1	7.3
325,000	375,000	346	53.4	24.7	7.3
442,000	500,000	379	68.0	24.5	9.5

10.2.2 Liquid Gas Carriers

Marine transport of LNG (mainly methane, relative density about 0.45) and LPG (a mixture of mostly propane and butane, relative density about 0.6) takes place in refrigerated

form, LNG at a temperature of about -165°C and LPG at about -50°C . The only exceptions are some small coastal tankers that carry pressurised LPG (at about 7 bar). LNG can be liquefied by very high pressure (Compressed Natural Gas or CNG), which is transported in relatively small steel cylinders. Similarly the carriage of pressurised LPG in big ships would require too large wall thicknesses for the cargo tanks.

The *load capacity* of liquefied gas carriers is always given in cubic metres instead of dwt. Dimensions are given in Table 10.2.

Table 10.2 Dimensions of liquid gas carriers

cargo [m ³]	water displacement [t]	length L_{oa} [m]	width [m] [m]	fully loaded draught [m]	fully loaded freeboard [m]
10,000	15,000	138	19.2	7.0	4.3
35,000	43,000	187	27.0	10.5	7.8
75,000	69,000	220	34.8	11.5	9.2
125,000	110,000	278	42.0	13.6	14.5
210,000	149,000	315	50.0	12.5	14.5
266,000	179,000	345	53.8	12.2	14.8

The last two sizes have been recently built for the transport of Qatar gas and are therefore referred to as Q-Flex and Q-Max respectively. The possibility of regasification on board of the vessel has been added to some classes of vessels allowing to use the gas as fuel.

There is a considerable difference in draught between LNG/LPG carriers and oil tankers as shown in Table 10.3.

Table 10.3 Difference between LNG and VLCC

		LNG 133,000 [m ³]	VLCC 150,000 [t]
length	$[L_{PP}]$	280	297
width	[m]	42	44
draught	[m]	11.5	17.1
load capacity	[t]	60,000	150,000
loaded freeboard	[m]	14.5 - 16.5	5.5

The draught of the LNG tanker in ballast is only slightly less than the loaded draught, as the tanker has to take in a relatively large quantity of ballast water for stability reasons.

Table 10.3 also shows the high freeboard figure for the LNG vessel, which results in a high resistance to wind. Especially in case of spherical tanks (*Ross-Mosenberg type*) where the tanks extend approximately 17 m above the deck, the influence of the wind is considerable. The low density of the cargo and the high position of these ships lead to significant differences with oil tankers as regards their behaviour in waves.

10.3 The Nature of the Products

The liquid form in which oil and gas are transported, enables rather high (un)loading capacities of up to approximately 25,000 t/hour (crude oil) and m³ per hour (LNG). Vessels smaller than 200,000 to 250,000 t can load or unload with net hourly capacities equal to 10% of their deadweight tonnage. Consequently, these ships occupy the port facilities for a short period only, about 1 to 1.5 days including time for cleaning, ballasting etc. Loading is performed by shore-based pumps, unloading by ship-based pumps.

The liquid state permits off-shore loading and unloading by means of pipelines, hoses and mooring buoys. In case of crude oil and oil products, this may be done through sub-marine pipelines and floating single-point moorings (SPM's). For refrigerated gases, the technology for sub-marine cryogenic pipelines and SPM's has not yet been developed, but floating storage and regasification units (FSRU) are now available.

Another important characteristic of oil and gas is the in flammability. In consequence, there are strict *safety requirements* for the transport, handling and storage of these products, especially for liquefied gases. The relative density of a typical Middle-East crude is about 0.85. For LNG, this is between 0.43 and 0.50, and for LPG between 0.58 and 0.60. Propane, as a component of LPG, liquefies at atmospheric pressure at a temperature of -50° C, LNG at -162° C to -165° C. The volume of the LNG is thereby reduced to 1/600th of the original volume.

Figure 10.1 shows the relation between temperature and minimum pressure required to liquefy different gases.

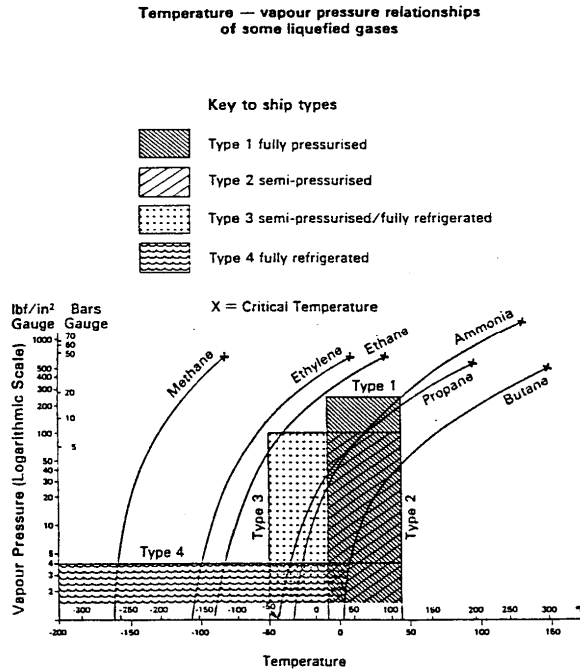

Figure 10.1 Relation between vapour pressure and temperature of different gases

10.4 Terminals

10.4.1 General

The shape, dimensions, locations and arrangement of terminals are dictated by their function. This can be:

- Transshipment and storage (e.g. Maasvlakte Oil Terminal Rotterdam, Bullen Baai Curacao)
- Supply to refinery and distribution from refinery
- Combination of both foregoing possibilities (e.g. Shell Europoort)

The diversity of products has to be taken into account. Terminals belonging to refineries have a more or less fixed pattern of requirements regarding facilities, dictated by the volume and origin of the crude imported and the range of products produced.

Typically, a medium-sized refinery, with an annual throughput of 5 to 6 million tons, would need facilities to receive, say, 25 to 30 VLCC's of 200,000 t per year. The products may be exported in some 100 to 240 product tankers in the 25,000 to 50,000 t range. Two to three berths would be required to accommodate these ships.

If no sheltered deep-water port already exists, it may well be economically attractive to unload at an offshore SPM/SBM and, thus avoid having to dredge the channel and basins

and to build a jetty for big tankers. In that case, two berths, able to receive 50,000 t product tankers, would be sufficient.

For bigger throughputs, the SPM solution becomes less attractive because of lower unloading rates (as compared to a fixed jetty), greater delays and greater threat of pollution. Also the mooring and unmooring of the vessel at the buoy requires tug- and service boats to go out, which limits the accessibility during bad weather.

Simulation models will have to establish the actual requirements for berths, (un)loading capacities and storage capacities.

10.4.2 Types of Terminals

The most important parameters for the choice of type are:

- Cost
- Safety
- Reliability

The cost calculations need to include:

- Inaccessibility due to current, waves, wind, visibility, etc.
- Maintenance (e.g. dredging)
- Influence of future extensions, if expected

The following types of oil terminals can be distinguished:

(i) *Conventional sheltered port with storage areas.*

The berth mainly consists of a jetty (Figure 10.2) and dolphins.

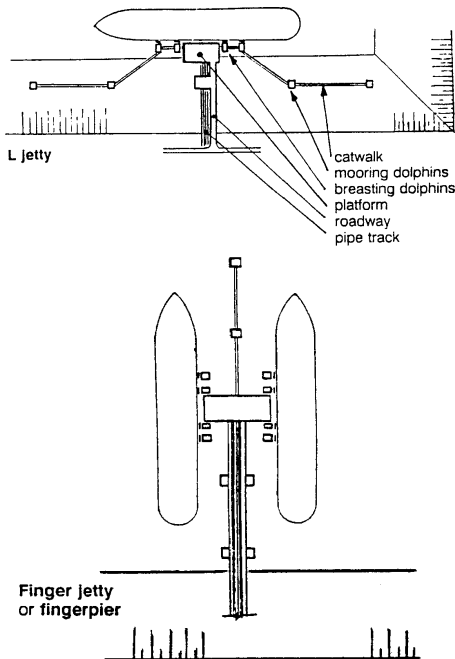

Figure 10.2 Types of jetties

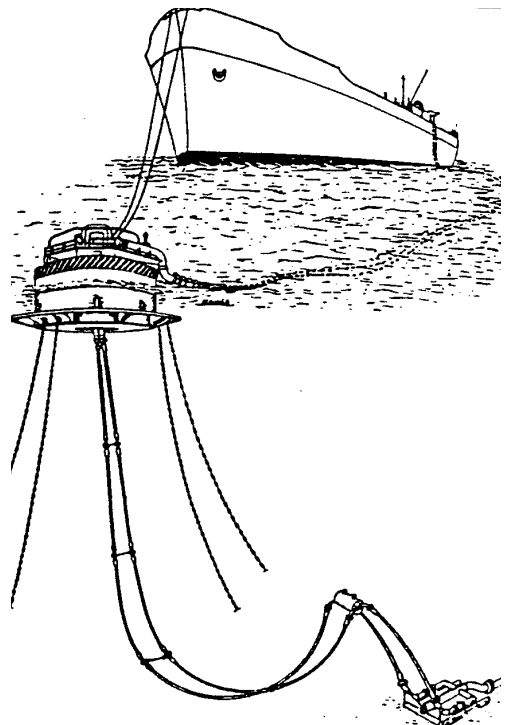

Figure 10.3 Single buoy mooring (SBM)

¹LFL: Lower flammable limit

²LEL: Lower explosive limit

(ii) *Offshore multiple buoy moorings (MBM) and single buoy moorings (SBM, the most common form of single-point moorings, SPM, used in case of large ships and insufficient water depth near the shore (Figure 10.3)).*

The traditional offshore terminal consists of MBM or SBM with sub-marine pipelines to the shore where storage takes place. The pipelines can be dug in, but this is not always necessary. Trenching (digging in) may be required for:

- the stability of the pipeline (currents and waves)
- protection against damage (anchors, fishing gear)
- the avoidance of unacceptable stresses in the pipeline due to small bend-radii or long free spans

The sand or gravel cover of the pipelines ranges from 0 to 5m, depending upon the location and the circumstances.

(iii) *Offshore terminals with floating storage*

This new application can be economic in cases of small or remote oilfields. The terminal is an SBM with a permanently moored storage vessel (FSU). Tankers come alongside this vessel for loading (Figure 10.4). For the *loading and unloading of liquid gas*, mostly ports are used. Exceptions are a floating LPG import facility in Beirut, Lebanon and an unsheltered, but fixed offshore LNG loading terminal in Brunei. Only recently Floating LNG Storage and Re-gasification Units (FSRU) have come into service (see Figure 10.5). Their operating method is very similar to the FSU, but the FSRU needs more protected water in view of the vulnerability of the ship-to-ship cryogenic pipelines.

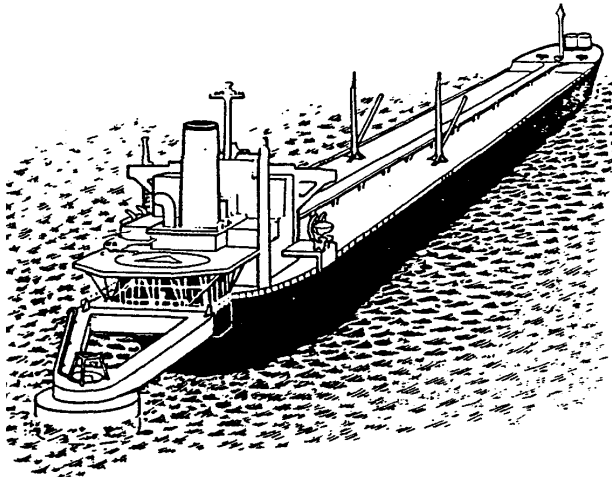

Figure 10.4 Floating storage



Figure 10.5 FSRU with shuttle carrier, Bahia Blanca, Argentina

10.4.3 Location of the Terminal - Safety Considerations

The location selection is based on the following considerations:

Export or import For the export terminal, the location of the oilfield or gas field is the main determining factor. For the import terminal, the suitability of the site and the presence of sheltered natural or artificial deep-water harbours will often dictate the choice of a site for the terminal and/or refinery.

Storage area Availability of an adequate area for tank farm and, possibly, refinery. Geotechnical factors can be important.

Water depth The available water depth in relation to the draught of the envisaged vessels and the required initial and maintenance dredging are also important factors.

Safety and reliability This concerns the technical as well as the operational safety and reliability. The technical safety and reliability refer to matters as, e.g.:

- Sheltered berthing
- No seiches in the harbour basin
- No sudden siltation in the entrance channel

The operational safety and reliability concern:

- Storm frequency
- Persistent low water conditions
- Regular visibility problems
- Night-sailing restrictions
- Tidal restrictions

- Presence of good functioning port services
- Presence of tug assistance
- etc.

With regard to safety, it must be mentioned that the surroundings of the terminal and the refinery need to be protected against the hazards associated with the terminal, and vice versa. Due to the nature of LPG and LNG, the consequences of spills can be more severe than with oil terminals, because the liquid gas evaporates faster (consequently, gas clouds may form) and because fires produce, in general, a greater heat radiation.

Thus, for terminal planning purposes, different safety distances have to be taken into account:

- The distance to possible leakage or spill sources on the terminal within which vapour clouds may develop with an inflammable or explosive density (density above LFL¹ or LEL². Within these boundaries, no uncontrolled ignition sources may occur.
- The distance to possible fire sources in the terminal within which heat radiation may cause physical harm to people.
- In case toxic products are used or processed, the distance to possible leakage or spill sources within which vapour clouds may develop with a density that, again, may cause physical harm to people.

For the calculation of these safety distances, reference is made to Sandia (2004) and Ligteringen e.a. (2007).

It will be clear that the possibility of spills must be reduced to the utmost minimum. In consequence, all oil and gas terminals should be located in special port basins that are not accessible to other traffic and can be easily closed off by floating booms in case of accidents. Furthermore, the (un)loading rates can be restricted, so that in case of e.g. a rupture in the loading arms, the size of the spill can be limited, depending also on the closing speed of the emergency valves. Various other safety measures are taken by the terminal operators to reduce the possibility of calamities.

However, relatively small events like the rupture of pipes or flexible hoses, the failure of valves, flanges, seals or gaskets, will occur occasionally, even on the best run terminals. It is particularly for these 'routine events' that the strict abidance to safety distances is important to minimise the effects.

At the other extremity, there are the major accidents like main tank failure which can result in catastrophes that are almost impossible to defend against by safety distances. E.g., TNO in the Netherlands calculated that if a 28,000 m³ load tank of an LPG carrier is ruptured and ignites, a column of fire will develop with a diameter of 600 m and a height of 550 m for a duration of 6 min; first degree burns will be sustained up to a distance of 2200 m. With delayed ignition, an explosion may occur (with LPG, but not with LNG) which, under unfavorable weather conditions, leads to a loss of 10% of the living quarters at a distance as far away as 7 to 11 km.

For these major accidents, the best and only defence is to take such precautions, both in planning, design and in operational procedures, as to bring the probability of occurrence at an extremely low level. For example, other ship traffic may be stopped in the neighbourhood of an LNG tanker sailing within a port's boundaries and low-visibility navigation may be prohibited. Also, LNG storage tanks are provided with a double wall, so that in case of an in itself very improbable failure of the inner cryogenic tank, the product will be contained within the concrete outer wall (Figure 10.6).

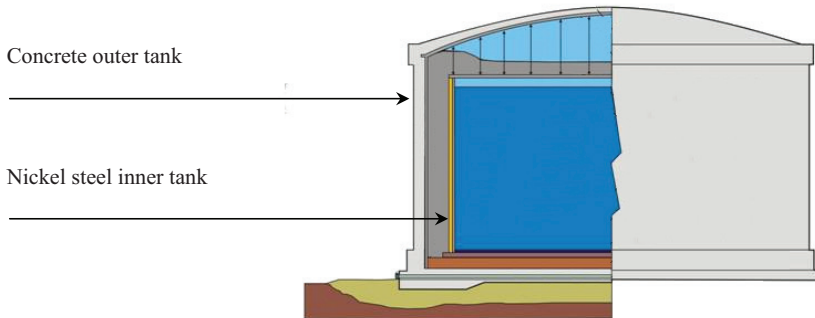

Figure 10.6 Full containment tanks 150,000-200,000 m³

10.5 The Berth

The location of the oil terminal berth can be in open sea or bay, as well as inside a harbour. Local conditions dictate the best choice. While in Europe harbours and river mouths offer the required protection, it is a widespread practice in the Middle East to locate the terminals offshore (Ras Tanura, Kuwait, Kharg Island).

For the feasibility of offshore fixed berths, waves and currents are the decisive parameters. In case of swell (periods more than 12 s), a good orientation towards the wave direction is a necessity. But, an orientation parallel to the local currents is equally necessary.

Table 10.4 very roughly shows the limiting wave heights that apply for the use of jetties and SBM's.

Table 10.4 Limiting wave heights for jetties and SBM's

	during berthing without swell [m]	during berthing with swell [m]	during loading or discharging [m]
<i>jetty</i>	1.5 - 2.0	1.0 - 1.5	2.0 - 3.0
<i>SBM</i>	2.0 - 3.0	2.0 - 3.0	4.0 - 6.0

The figures for the jetties very much depend upon the arrangement of the mooring system, orientation towards wave direction and shape of the wave spectrum. Of course, there is also

a strong influence of currents and wind. Berthing with wind speeds higher than 12.5 to 15 m/s is considered to be unsafe, and is, therefore, not allowed.

Considerations of excessive wear and tear of the fender system may reduce the limiting wave height at a jetty during loading and unloading well below the above given figures. The offshore solutions are further discussed in Section 10.7 hereof.

For a conventional berth inside a harbour basin, the following principles have to be observed:

- For safety reasons, oil and gas berths should be separate from other port facilities. No other shipping should be allowed inside the oil and gas basins.
- The berth shall preferably be fugitive, i.e. the ship can stay at berth under all weather conditions. When this is not possible (for economic reasons) the storm warning procedures shall allow timely and safe departing of the ship. This very much applies to liquid gas tankers, as these can only sail with either full or empty cargo tanks. ('Empty' means with 1 or 2% residual cargo to keep the tanks refrigerated on the return voyage. Contrary to oil tankers, gas tankers have no partitions in their cargo tanks, which, when in open sea, would lead to sloshing of the liquid in the tanks if only partially filled. This, in its turn, could cause rupture of the tank wall as well as loss of stability of the ship.

As concerns the length of waterfront required per berth, for safety reasons the space between two ships, berthed in line, should be approximately equal to the width of the biggest ship. It should also be taken into account that the manifold of many ships is not located exactly in the middle of the ship, but sometimes up to 15 m fore or up to 10 m aft of the centre. It is, therefore, advisable to take as a minimum centre-to-centre distance of 2 adjacent berths: the length of the longest ship + 1 x the width of the largest ship + 2 x 15m.

10.6 Jetties and Dolphins

10.6.1 L and T Jetties

Oil and gas jetties (Figure 10.7) generally consist of the following components:

- An *approach bridge* with a roadway of 2.5 to 3.5 m width and a pipe rack (preferably in one layer for easy inspection), plus service ducts, lighting and guard rails. The pipe rack can be either next to the roadway and on the same level, or underneath the road. The length of approach bridges varies, depending upon the local conditions, from tens of meters to many kilometres.
- The *jetty head* consisting of a platform with:
 - Loading arms
 - Service area
 - Service building
 - Jetty crane
 - Fire fighting tower

10 Liquid Bulk Terminals

- Gangway
- etc.

A typical size of a jetty head is 20 x 35 m²

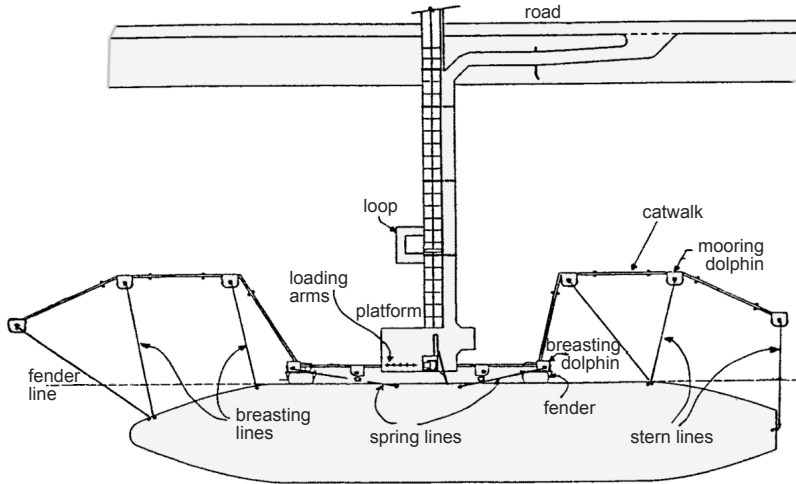

Figure 10.7 L jetty arrangement

- The *berthing or breasting dolphins* which serve to:
 - Absorb the kinetic energy of the berthing ship
 - Hold the vessel during on-shore wind
 - Fasten the 'spring' lines of the vessel (although, sometimes, also special mooring dolphins are used)
- The *mooring dolphins* to fasten the transverse mooring lines (breast, fore and stern lines).

The difference between L and T jetties is caused by the lay-out of the approach bridge and jetty head. An L jetty has the bridge at one of the sides of the platform, while at a T jetty the bridge is centrally positioned. A possible advantage of the L jetty is that it provides space at the inner sides of the platform for small craft (tugboats), but otherwise the choice is based on the configuration of pipelines on the platform, connecting to the bridge.

The overall lay-out of platform, breasting and mooring dolphins is following the guidelines prepared by the *Oil Companies Marine Forum (OCIMF, 2008)*. These are aimed at providing optimum effectivity of the mooring arrangement and at standardisation. The principles are given in Figure 10.8, taken from these guidelines.

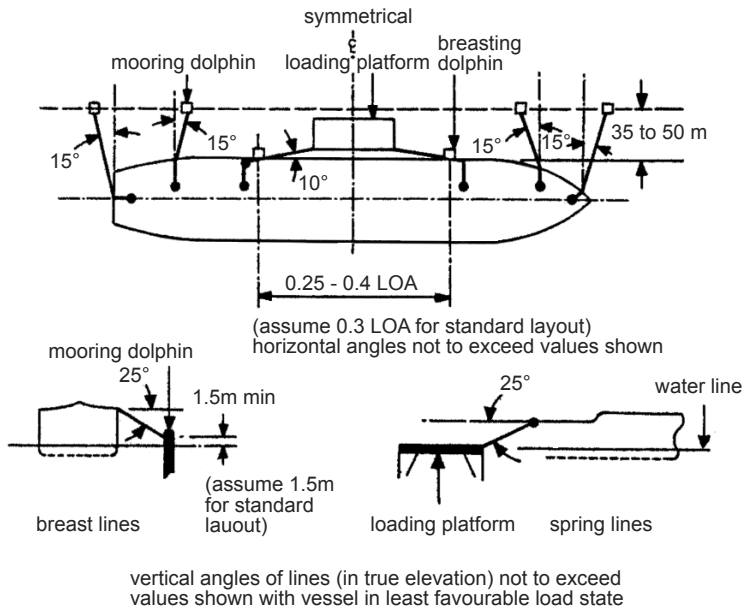

Figure 10.8 Typical mooring pattern

The lay-out is symmetrical with respect to the centre line of the platform (tankers have their manifold at or near the middle of the ship and must be able to head into one or the other direction, while at berth). Mooring lines fore and aft should have a maximum angle of 15° in the horizontal plane with the normal to the ship, because these lines restrain the lateral movements of the ship and have thus optimum effectivity. The spring lines should have a maximum angle of 10° with the longitudinal axis in order to function most effectively in restraining the surge motion. Likewise the maximum angle of all mooring lines in the vertical plane is limited to 25° with the horizontal. This is possible (given the normal difference in elevation of the fairleads in the ship hull and the hooks at the dolphins) by having sufficient length of the line. It is for this reason that the *mooring dolphins* are positioned behind the *breasting dolphins* at a distance of 35 to 50 m.

It is clear that this lay-out can only be realised when there is just a small variation in the size of tankers / carriers to be received. When this is assured, it is sufficient to have only two breasting dolphins, each at about $(1/3) \cdot L_s$ from bow and stern. When the variation in ship size is considerable it is necessary to add one and sometimes two breasting dolphins to satisfy the requirement that the space between two dolphins does not exceed $0.4 \cdot L_s$. In such cases also additional mooring dolphins may be placed.

10.6.2 Finger Piers

Finger piers have the advantage of having berths at either side of the pier, with the possibility of joint use of the approach bridge, platform (partly) and mooring dolphins. But, care should be taken that the distance between ships does not become too short, causing mooring lines to become too steep. With the above mentioned minimum distance from ship

to dolphin of 35 m this would lead to a platform width of more than 70 m, which is in most cases unnecessary.

10.6.3 Approach Bridges and Jetty Heads

Approach bridges and jetty heads are, in essence, simple structures for which local building regulations apply. In case of exposed jetties the elevation of underside deck requires calculation of design water level and wave height under design conditions. In order to avoid high slamming loads the deck elevation shall be chosen well above design water level. For the roadway loading, the design load is the biggest vehicle that passes during normal use, unless the building or maintenance of the jetty as such entails special requirements. Normally, a 15t truck constitutes a reasonable design criterion.

In many cases, the design of the approach bridge is determined by the number and dimensions of the pipelines. Spans for the pipelines may not be too big (4 to 12 m) due to the stiffness requirements. Special attention has to be paid to pipeline anchors and expansion bends (loops). In case of LNG lines, often bellows are used, instead of loops.

When designing approach bridges, it is highly desirable to let the pipeline anchors coincide with the fixed points of the approach bridge. Expansion bends should coincide with the expansion joints of the bridge. The bridge has to be sufficiently rigid in all directions. The vertical deflection should be no more than 1/1000 of the span to prevent that, when draining the lines, a residue of the product remains in the pipeline.

The dimensions of the jetty head are mainly determined by the space requirements of the manifold and the loading arms. The required minimum distance between successive loading arms is 3 to 4.5 m, depending on their size.

10.6.4 Breasting Dolphins

In Section 10.5.1 the functions of breasting and mooring dolphins have been mentioned. Since breasting dolphins (also called *berthing dolphins*), contrary to mooring dolphins, have to be able to absorb the kinetic energy of the berthing ship, they have to be flexible. This flexibility can be attained either by elastic deformation of the dolphin itself (e.g. by using a number of relatively small-diameter, thick-walled steel piles) or by elastic deformation of the fenders, or by a combination of the two. *Mooring dolphins* have to withstand only quasi-static loads and, as such, are most economically designed as stiff structures (e.g. a single large-diameter steel pile).

The berthing of ships in general, but of VLCC in particular because of their great mass, has to be done extremely cautious. The procedure is that the ship is brought alongside the berth with no forward speed and then pushed carefully toward the berth by tugs or use of bow thrusters. Preferably the forward breasting dolphin is reached first by creating a small angle between the ship axis and the berthing line. In Figure 10.9 this angle is exaggerated.

The impact energy to be absorbed by the dolphin / fender combination is calculated by the following formula.

$$E = \frac{1}{2} \cdot M \cdot v^2 \cdot C_m \cdot C_e \cdot C_s \cdot C_c \quad (10.1)$$

in which:

- E = kinetic energy of berthing ship [kJ]
- M = mass of the ship (displacement) [t]
- v = approach velocity of ship's centre of gravity at time of impact [m/s]
- C_m = added mass coefficient [-]
- C_e = eccentricity coefficient [-]
- C_s = stiffness coefficient [-]
- C_c = configuration coefficient [-]

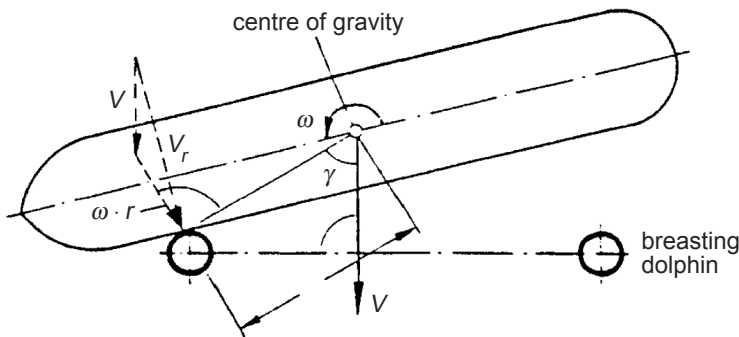

Figure 10.9 Berthing ship

The factor C_m has to be introduced to incorporate the effect of a volume of water that moves with the vessel, the so-called *added mass*.

$C_m \cdot M$ is the virtual mass of the vessel, comprising the ship's mass and the added mass. The value of C_m depends, inter alia, on the keel clearance, the approach velocity and the deceleration gradient after contact with the dolphin. Extensive research was carried out at Delft University of Technology on this important factor (Fontijn, 1980) and (Vrijburg, 1983), resulting in the following approximative expression:

$$C_m = 1.2 + 0.12 \cdot \frac{D}{h - D} \quad (10.2)$$

in which:

- h = water depth [m]
- D = draught [m]

Note 1: the above equation applies to ships moving sideways during berthing, when the effect of added mass is strongest.

Note 2: several manuals and standards, like British Standard BS 6349 (1994) and EAU

(1990) give another expression for $C_m (= 1.2 \cdot D / B_s)$, proposed by Vasco Costa (1964). This does not represent the effect of small underkeel clearance, as is the case in most berth conditions.

The *eccentricity coefficient* C_e takes account of the rotation of the ship during berthing, in addition to the translation. C_e is approximated with the following expression:

$$C_e = \frac{k^2 + r^2 \cos^2 \gamma}{k^2 + r^2} \quad (10.3)$$

in which:

r	=	distance between c.g. and the point of first contact	[m]
k	=	radius of gyration of the ships mass around the c.g	[m]

According to BS 6349 k is a function of the ship length and block coefficient C_B :

$$k = (0.19 \cdot C_B + 0.11) \cdot L_s \quad (10.4)$$

With k for most ships ranging from $0.2 - 0.3L_s$ and r amounting to about $0.25L_s$ in the above procedure, a value of $C_e = 0.5 - 0.8$ is found. For a theoretical treatment reference is made to Vasco Costas contribution in Port Engineering (Bruun, 1989).

The *factor* C_s depends on the relative elasticities of the dolphin and the ship's hull, as some of the energy may be absorbed by elastic deformation of the latter. When the dolphin and fender are stiff, the hull will yield giving a value of $C_s = 0.9$. In case of soft fendering $C_s = 1.0$ should be used. C_s is thus only of secondary importance.

Finally the *configuration coefficient* C_c accounts for the types of berthing structure. For open jetties like described in this Chapter a value of $C_c = 1.0$ applies. But in case of a closed quay wall, such as a sheet pile structure, $C_c = 0.8$ may be used. The reason for this is that the water between the wall and the approaching vessel can not escape quickly enough from around and under the vessel and will act as a cushion.

As a rule of thumb to estimate the kinetic energy at berthing Equation (10.1) may be simplified to:

$$E = \frac{1}{2} M \cdot C_b \cdot v^2 \quad (10.5)$$

with $C_b = 0.7$ representing the combined effect of the four coefficients described above. It should be recognised that this is a very rough estimate.

It will be clear that the magnitude of the impact energy is largely determined by the approach velocity of the ship. As a simple guideline may serve:

- Favourable conditions of current and wind $v = 0.10$ m/s
- Average conditions of current and wind $v = 0.15$ m/s
- Unfavourable conditions of current and wind, or berthing with smaller vessels $v = 0.25$ m/s

More detailed recommendations are given in EAU, 1990, and PIANC, 2002, see Figure 10.10. The values given in these references are considered to be quite conservative and recently a new PIANC Workgroup has started to collect full-scale data of berthing velocities in order to update the existing Guideline.

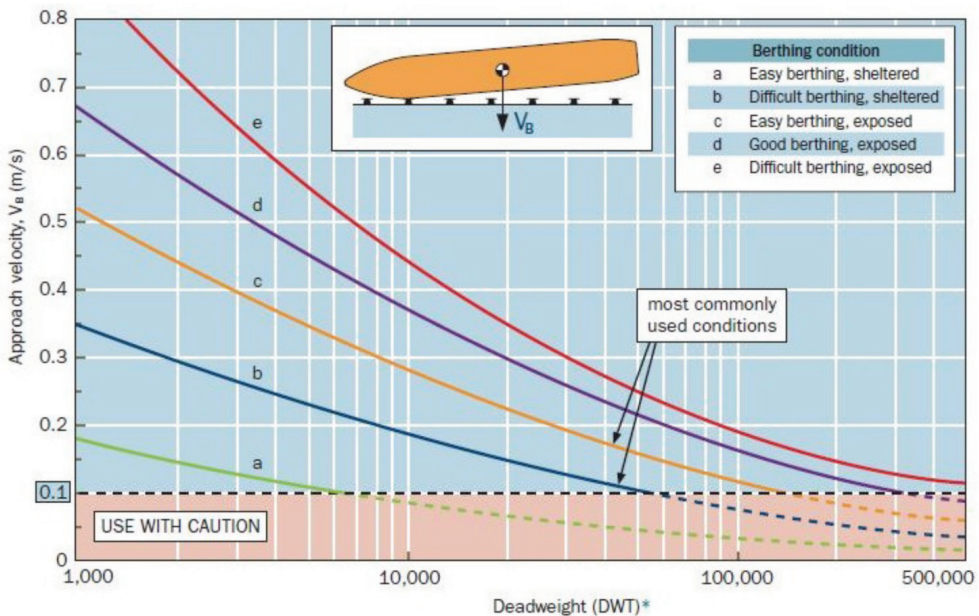

Figure 10.10 Berthing velocities

The availability of statistics for different classes of vessels allows the setting of design values based on an accepted probability of exceedance. British Petroleum measured dolphin and fender deflections, and thus impact energy, for an extended period (Balfour et al, 1980). For an accepted probability of exceedance of 1/3000 (or once per 20 years), this resulted in the design values tabled below. The design values given for Shell are partly based on approach velocity measurements, and partly on certain design philosophies, e.g. the fear that a long habit of berthing big ships at specific locations may result in a decrease of caution.

Table 10.5 Design values berthing energy

DWT	British Petroleum [kJ]	Shell [kJ]
50,000	103	120
100,000	152	183
150,000	185	250
200,000	215	345
300,000	260	515

Now we have to apply the *berthing energy* into the design of the dolphin including the selection of a suitable fender. At first impact the berthing energy will result in compression of the fender mounted on the dolphin and deflection of the dolphin. For the piles of a dolphin there will be essentially a linear relation between the force F and the deflection y_p :

$$F = k_p \cdot y_p \quad (10.6)$$

with k_p = pile stiffness (N/m)

Most *elastomeric fenders* show a non-linear force deflection curve with y_f as design compression (see Figure 10.11). Equating the (kinetic) berthing energy with the maximum potential energy in the breasting dolphin:

$$E = \frac{1}{2} F \cdot y_p \cdot y_p + \int_0^{y_f} F \cdot y_f \cdot d_y \quad (10.7)$$

will allow to calculate the berthing force. In first approximation a different approach is followed in design. Because the deflection of *dolphin piles* is very small compared with the compression of the fender, the design procedure neglects the former component:

- i. Based on the berthing energy E a suitable fender is selected (from energy absorption- deflection curve, such as Figure 10.11b);
- ii. In the corresponding force-deflection curve, such as Figure 10.11a, the design force is determined;
- iii. Subsequently the *breasting dolphin* is dimensioned on the basis of this design force, taking into account the lateral friction force. Because the ship may still have some forward speed at the instant of impact the friction between ship hull and fender surface creates an additional force of about 0.5 F parallel to the berthing line. The fender is designed to resist this lateral force safely, but the dolphin design shall be based on the resultant of the normal force and lateral friction force.

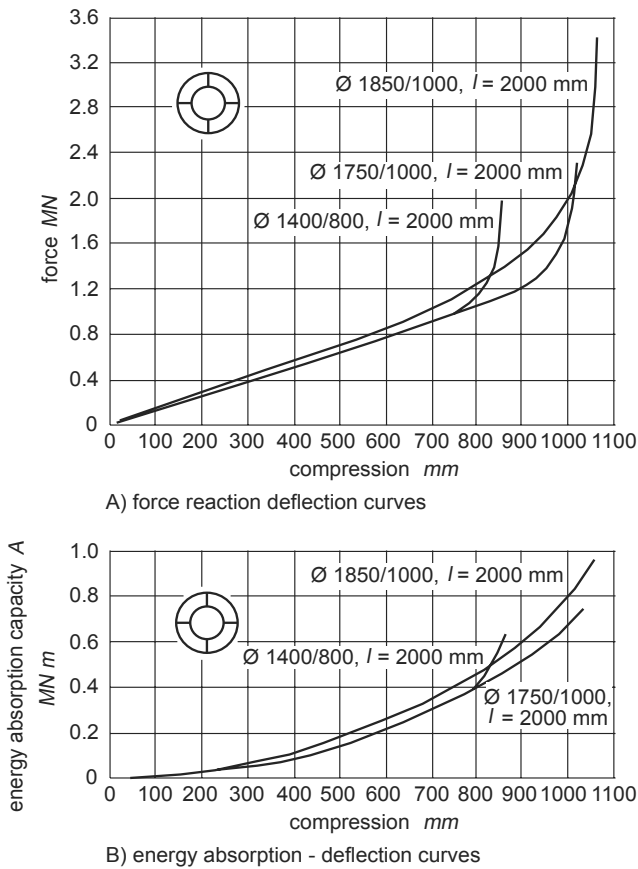

Figure 10.11 Force deflection curves and energy absorption curves of large-diameter cylindrical fenders

It is not only the breasting dolphin that has to be able to withstand the impact force F , but also the ship's hull may not sustain damage. The permissible hull pressure is 200 kN/m^2 for LNG/LPG tankers (and for dry bulk carriers), 250 kN/m^2 for oil tankers up to about 100,000 t, and 300 kN/m^2 for oil tankers above that limit. However, in view of the IMO regulation that new oil tankers have to be provided with a double hull (i.e. separate cargo tank), which will lead to a lighter outer hull structure, it would appear safe to assume a generally applicable limit of 200 kN/m^2 . The fenders or fender skirts will have to be designed and dimensioned accordingly, and fender skirts must be mounted on the dolphin in a flexible way, so as to be able to adapt themselves to the position of the ship's hull.

In the above, only the design requirements resulting from the energy absorption function have been discussed. Design requirements resulting from quasi-static forces transmitted by a ship exposed to waves, wind and/or current, are usually less than the berthing force and therefore not determining for that reason) is laid out assuming in each line a maximum load of $0.55 \cdot \text{MBL}$.

To avoid that mooring dolphins are overloaded and damaged due to the use of more or stronger lines than assumed in design the following safety is introduced:

- i. The winches on board of the vessel have a brake, which slips at a force of 0.6 MBL
- ii. The dolphins are designed for a load equal to the number of lines MBL (the design includes a load safety factor according to the applied Design Standard)



Figure 10.12 Multiple quick release mooring hook with a capacity of 150 tonnes per hook

Modern berths have their mooring dolphins equipped with Quick Release Hooks (QRH), which can be operated mechanically and can be programmed to release the lines when the force exceeds MBL, see Figure 10.12. Jointly, the mooring dolphins (and mooring lines) should be able to resist any wind and current force exerted on the ship, that would move the ship away from the berth.

In case of *exposed jetty terminals*, the dolphins (both breasting and mooring dolphins) must also be able to resist the forces directly or indirectly induced by the waves. Normally, all-steel mooring lines, or hawsers, are used for tankers, but in case of appreciable exposure to waves, softer moorings (e.g. steel with nylon 'header' or 'tail') may be required to limit mooring line forces. This leads to greater ship motions which may make it necessary to disconnect the loading arms if the motion amplitude starts to exceed certain critical values. Normally, for long-period horizontal motions surge, sway and yaw, amplitudes of 2.5 to 3m are allowed. LNG loading arms often have an *auto-disconnect* set at 2.5 m.

Some load/elongation curves for different types of mooring lines are given in Figure 10.13

To verify and optimise mooring arrangements for berths in difficult situations, numerical programs are used, that calculate the fender and mooring line forces, and the ship motions in six degrees of freedom in the time domain. The reliability of these computations is good for relatively simple berth configurations. When the berth is located in a complex geometry (e.g. inside a harbour with incoming waves and reflections) a physical model is

still employed besides numerical models, such as the combination of a Boussinesq wave propagation model with a model to compute the forces on and the motions of the moored ship (Van der Molen, 2006).

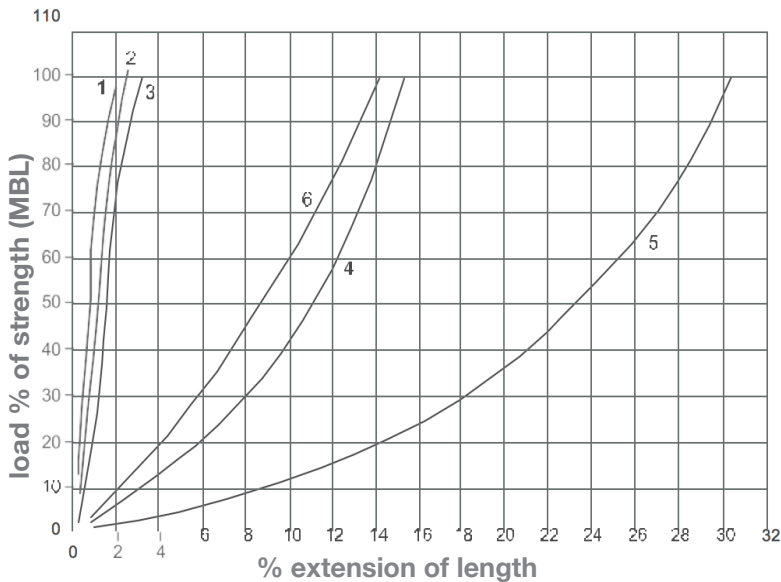

Figure 10.13 Load extension curves for mooring lines

1. Steel core wire (6x36 ordinary lay)
2. Steel core wire (6x25 ordinary lay)
3. Advance main-made fibre
4. Nylon braid line
5. Nylon square line
6. Polypropylene line

10.6.6 Special Aspects of LPG/LNG Jetties

The following aspects require special attention:

- The stringent safety requirements have an influence on the design in the form of more conservative values for safety coefficients, acceptable stresses, etc.
- In the case of leakages or spills anywhere in the pipeline system, the very low temperatures of LNG can expose steel structures to so-called cold showers which cause an irreversible brittleness. Therefore, exposed steel structures have to be protected, e.g. by applying a cover of concrete or by incorporating the structure in a concrete floor.
- For the design of various parts of the jetty, especially the loading platform, spatial forms have to be avoided which facilitate the development of so-called *gas pockets*.
- By applying insulation material around the pipelines, the surface exposed to the wind doubles or trebles with subsequent higher wind forces.

- Acceptable deformations and rotations of the structure are small and are also determined by the nature of the applied isolation materials.
- An elaborate system of fire-fighting equipment is required.

The isolated pipelines for transport of LNG from the berth to the storage tanks are very expensive. This prohibits transport over long distance.

10.7 Storage Areas

The size of storage areas for oil and liquid gas depends on the number and dimensions of the tanks and the distances between these tanks. Space has to be added for pipe racks, roads, pumping stations, buildings, etc. The dimensions of the tanks depend upon the size of the vessels, the intervals between ship arrivals and the diversity of the products.

In case of oil tanks, the distance between the tanks is mainly determined by the criterion that each tank has to be surrounded by a concrete or earth wall (bund) at such a distance and of such height, that in the event of the collapse of a full tank, the oil can be contained within the bund. For example, a tank of 100,000 m³ surrounded by a 5 m high bund (4 m useful) requires a surface of 25,000 m² or 160 m · 160 m.

Operational storage capacity is, generally, in the order of 1 month consumption. In addition to this, there may be a strategic storage. The costs of LNG/LPG tanks is much higher than that of other tanks, so operational storage capacity is kept to a minimum.

Liquid gas storage is more dangerous than oil storage, and requires special safety provisions as discussed already earlier. E.g., any escaping liquid from pipeline or tank rupture should be contained in as small as possible an area to minimize the evaporation surface.

As a guideline for space requirements, an LNG terminal with a throughput of 6 million m³ per year requires, roughly, 15 to 20 ha for storage, in 4 tanks of 60,000 to 80,000 m³ each. This direct need for space is exclusive of the safety zone which must be kept free of uncontrolled sources of ignition.

10.8 Offshore Facilities

10.8.1 Multiple Buoy Mooring (MBM)

The simplest offshore berth facility is the Multiple Buoy Mooring, also referred to as *Conventional Buoy Moorings* (CBM). Flexible hoses are connected to pipelines laid on the seabed, which run to or from the tank farms on the land. When no vessel is at berth, the flexible hoses are set down on the seabed, with pick-up rigging connecting the end of the hose to a *surface marker buoy*. Upon arrival the ship uses its own anchor lines and often additional wires, connected to surface buoys (which themselves are anchored by chains to pile anchors in the seabed). Having moored, the vessel uses its manifold derrick or crane

to attach the pick-up rigging and lift the flexible hose in order to connect it to the vessels manifold, located at mid-ships.

MBMs in the port of Beirut, Lebanon

The existing port of Beirut has eight oil and gas handling facilities along the coast, for products such as gasoline, jet fuel, LPG and chemical products. The products are imported via MBMs, located in a sheltered bay. The annual volumes are quite low, e.g. 40.000 m³ LPG, carried by some 35 vessels.

The lay-out of the MBM shows the 5 mooring buoys, each tied to 2 anchor piles.

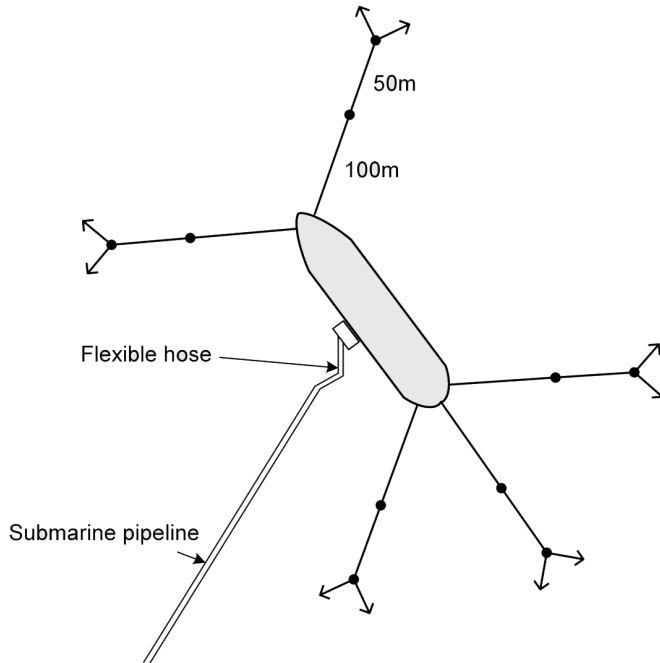

Figure 10.14 Multiple Buoy Moorings in the port of Beirut

The connection of the vessel to the buoy moorings is carried out using a small launch, which also brings the hose to the manifold area and connects it to the derrick/crane. When the sea is rough, this activity can't take place. As limiting wave height 1m is reported. This implies that MBMs only can be used in relatively sheltered areas.

Another limiting factor for application of MBMs is the long time required for berthing and deberthing (5 hours) in comparison with jetty and SBM (see Table 10.6). Also the discharge/loading rate is less than at a jetty. Finally the system is more susceptible to spills and therefore less acceptable under present day environmental requirements.

10.8.2 Single Buoy Mooring (SBM)

The advantage of an SBM is that the ship always takes the most favourable position in relation to the combination of wind, current and waves. Tankers of up to 50,000 t can be handled within 24 hours. The SBM is attractive due to the simplicity of the system and the low investment costs (compared to a jetty). Figure 10.15 shows an SBM with multiple-chain anchors. The system with 6- or 8-chain anchors is the most common.

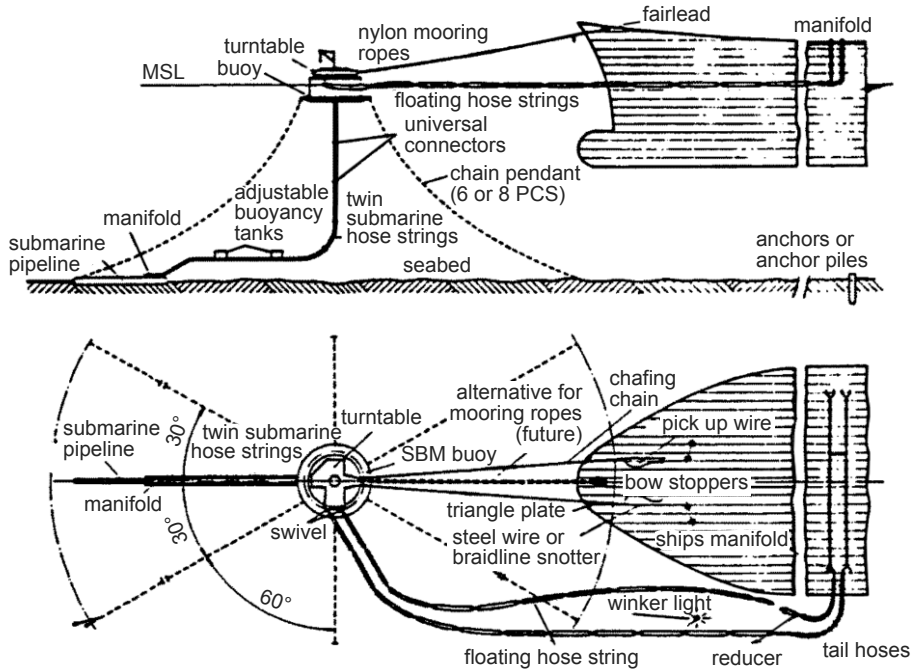

Figure 10.15 SBM with multiple-chain anchoring

As a comparison of the investment cost, a VLCC jetty, fully equipped and including local dredging, requires an investment of approximately 2.5 times the investment needed for an SBM with a 36 inch submarine pipeline of 5 km length. In addition to the differences in investment costs, there are the expenses for tug assistance which is required for vessels berthing alongside a jetty, but not often required for those mooring at SBM's. For the SBM a simple mooring launch is sufficient.

But, on the other hand, operation and maintenance costs for SBM's are considerably higher than for jetties. In particular, the hoses (underwater between pipeline and buoy, and the floating hoses between buoy and ship) require strict inspection and frequent replacement, although the technology has very much improved over the years. Furthermore, at arrival and departure of the tankers mooring launches and sometimes also tugs have to come out for assistance. In general, for small to moderate yearly throughputs SBM's are more economical than jetties. Only with big ships and for large throughputs, jetties become more economical.

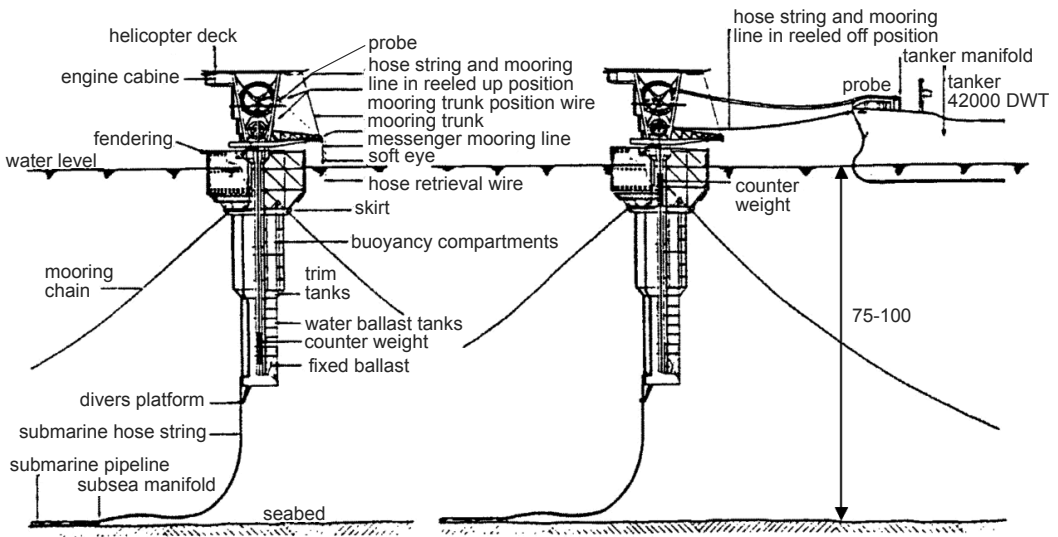

Figure 10.16 Deepwater SBM

The attractiveness of SBM's is also based on the fact that they can be used in very deep water (see Figure 10.16).

An *SBM buoy* mainly consists of the following components:

- Buoy body
- Turning table
- Swivel

The *buoy body* is divided into watertight compartments. There should be ample freeboard to avoid submerging of the buoy during maximum load. The maximum gradient may not exceed 10 to 15 degrees. The design load of the buoy should be equal to the break load of the hawsers. As regards selection of a buoy's location, it will be obvious that the sub-marine pipelines, i.e. the distance to the shore, should be as short as possible. But, it is equally obvious that there must be a zone of sufficient deep water around the buoy to ensure safe arrival and departure manoeuvres of the ships for different directions of wind, waves and currents. For that reason, the distance from the buoy to the critical water depth should be at least 3 times the length of the biggest ship.

Finally, Table 10.6 presents a comparison of the main design parameters of a jetty, an MBM and a SBM.

Table 10.6 Comparison of three mooring systems.

	jetty	multiple buoy moorings	SBM's
access from shore:	direct	by sea	by sea
number of hoses:	1 - 8	1 - 4	1 - 3
time between arrival and start of pumping:	2 hours	5 hours	2 hours
mooring possible with wind up to 40 knots and head waves of:	1.5 - 2.0 m	2.0 - 2.5 m	3.0 - 4.5 m
oil unloading with wind up to 40 knots and head waves of:	1.5 - 2.0 m	2.0 - 2.5 m	3.0 - 4.5 m
ship has to leave berth with wind of 60 knots and waves higher than:	-	2.0 - 3.0 m	3.5 - 5.0 m
preference regarding ease of berthing and de-berthing:	2	3	1
possible tide effects:	yes	no	no
damage sensitive parts:	fenders	buoy chains	hoses
assistance during berthing and mooring:	tugs and flats	flats	flats
assistance for the departure:	tugs and flats	flats	flats

10.9 References

- Balfour J.S., Feben J.C. and Martin D.L., 'Fendering requirements, design fender impact criteria', Proceedings of Ports '80, ASCE, Norfolk, 1980.
- British Standard, Code of Practice for Marine Structures, BS6349, Part 4, 1994 Bruun, P., Port Engineering, Gulf Publishing Co., 1989
- Recommendations of the Committee in Waterfront Structures, Harbours and Waterways, EAU 2004, Wiley 2012
- Fontijn, H.L., The berthing of a ship to a jetty, Proc. ASCE Journ. Waterways, Ports, Coast and Ocean Div. 106, 1980
- Ligteringen, H., Tak, C. van der, Dirke, R. and Boer, F.A. de, LionGas LNG Terminal in Rotterdam, Proc. Int. Maritime-Port Technology and Development Conference, Singapore, Sept. 2007
- Maari R., 'Offshore mooring terminals', 1977
- Ministry of Social Affairs, Methods for calculation of the physical effects of the escape of dangerous cargo, Dutch Government Printers, The Hague, 1979
- Molen, van der W, Behaviour of moored ships in harbours. PhD Thesis, Delft University of Technology, Delft, 2006

Oil Companies International Marine Forum (OCIMF), Mooring equipment guidelines, Witherby and Co Ltd, Livingstone 2008
Sandia, Guidance on Risk Analysis and safety implications of a large spill over water, Report SAND 2004-6558, December 2004
Vrijburg A., Fender forces caused by ship impacts, Delft Hydraulics Publ. no. 309, Delft, 1983

Chapter 11

Dry Bulk Terminals

11.1 Introduction

Dry bulk cargo is mostly shipped in loose form, which determines to a major extent the transport technology employed at the quay and in the terminal. This and the storage systems make dry bulk terminals totally different from all other types of terminals.

One has to differentiate from the start between export and import terminals. Contrary to virtually all other terminals -liquid bulk, containers, general cargo-, the dry bulk terminals are mostly designed for one-way traffic only and, as a result, the loading and unloading terminals are basically different in character.

The best location of a dry bulk loading terminal (i.e. export) is not necessarily close to the main centre of commercial and industrial activities in the area, but rather in the vicinity of the origin of the commodity, e.g. near the mining centre. Important site selection criteria are the natural conditions, the land communications and the available depth of water, since large bulk carriers have a considerable draught. Due to the large quantities often handled in these ports, extensive storage facilities are required and the necessary land area has to be available. As a result, worldwide many of the big loading terminals are so called 'dedicated' terminals or ports, designed and developed to handle only one particular commodity, but in very large quantities.

Unloading or import terminals are much more diverse, both in location, size and cargo handling system. In consequence, a relatively large part of this chapter will deal with import terminals.

11.2 Dry Bulk Commodities

Dry bulk commodities can be divided into:

- iii. *major bulk*, e.g. iron ore, coal, grain, phosphate, bauxite/alumina.
- iv. *minor bulk*, e.g. sugar, rice, bentonite, gypsum, wood shavings & chips, salt, fish, copra

The total world maritime transport of minor bulk constitutes about one third of that of major bulk. A short description of the major bulk commodities is given below.

Iron ore

This is the most important dry bulk commodity, representing some 20% of the total dry cargo shipment by weight. The ore shipped has a stowage factor which varies between 0.30 m³ and 0.52 m³ per tonne, with an average of 0.4 m³.

Iron ore, generally, is dusty and so it is normally necessary to provide dust extraction equipment. The density of iron ore limits the stacking height in terminals because of the limits of the load-bearing capacity of the ground. The angle of repose is usually less than 40°. Sometimes, the iron ore undergoes a concentration process before being shipped. The concentrate is then baked into small spheres or pellets.

Coal

Coal has a stowage factor which varies between 1.2 m³ and 1.4 m³ per tonne. All types of coal, also anthracite, are subject to spontaneous combustion, caused by heating of the coal, as it absorbs oxygen from the air. But the sensitivity to this phenomenon differs from one type to another, which is important for the planning of the coal stockpile, as it may restrict the permissible height. Generally, the dust nuisance can be controlled by the use of water sprays at transfer points and discharge positions and on stockpiles. The angle of repose varies from 30° to 45° .

Grain

Under this heading belong wheat, barley, oats, rye, tapioca, etc. These grains have different densities and properties, so, consequently, they also have different storage and handling requirements. Since grain is a perishable commodity, it is necessary to have proper ventilation and protection against weather conditions and pests during shipping and storage. In the grain trade, variation in seasonal conditions results in large fluctuations in transportation requirements. Various types of vessels of different sizes are used, including combined carriers.

Phosphate

Phosphate rock is the main raw material for the fertilizer industry. It is very dusty and absorbs moisture very rapidly, which can create problems for unloading. The average stowage factor is 0.92 m³ to 1.0 m³ per tonne. Practically all shipments are in the form of a powdery concentrate. The material is very fine, and special provisions have to be made to prevent dust problems.

Bauxite/alumina

Bauxite ore, when processed into alumina, is the basic raw material for the production of primary aluminium. The two raw materials differ greatly in bulk density. Bauxite stows at 0.80 m³ to 0.88 m³ per metric ton, and alumina at 0.6 m³. Handling characteristics are also different. The trend is towards conversion of bauxite to alumina at the source, which halves the transportation requirements. Particularly alumina is dusty and requires precautions against soil and air pollution.

11.3 Dry Bulk Ships

Dry bulk carriers are designed for the transport of commodities such as grain, coal, iron ore derivatives, bauxite, phosphate, cement, etc. In the past carriers have also been designed and built for the transport of both dry and liquid bulk cargo. These were for example the so-called *OBO carriers* (ore/bulk/oil). Since the holds are alternatively used for the dry and liquid bulk cargo, they need to be cleaned at every change, which is a disadvantage. The *OCO carriers* (ore cum oil) had separate holds for liquid and dry cargo, in this way avoiding the many cleaning operations. Neither the *OBO* nor the *OCO* carriers have been used on a big scale, due to their limited application potentials. At present they are not built anymore.

The loading of bulk carriers virtually always occurs by shore-based equipment. Unloading may be done by shore-based equipment -the most common method- as well as by ship-borne equipment. In the latter case, one can distinguish between geared bulk carriers and self-unloaders. Geared bulk carriers are vessels equipped with deck-mounted grab cranes, generally one for every hold. Self-unloaders are equipped with a continuous unloading system. It usually consists of one or more longitudinal horizontal belt conveyors in the lowest part of the ship, which are fed from funnel-shaped holds through hydraulically operated valves or doors. The horizontal conveyor unloads onto an inclined or vertical conveyor which, in its turn, transfers the cargo on a third conveyor mounted on a revolving boom (up to 80 m long). From there, the cargo drops into a shore-based hopper (see Figures 2.31 and 11.1).

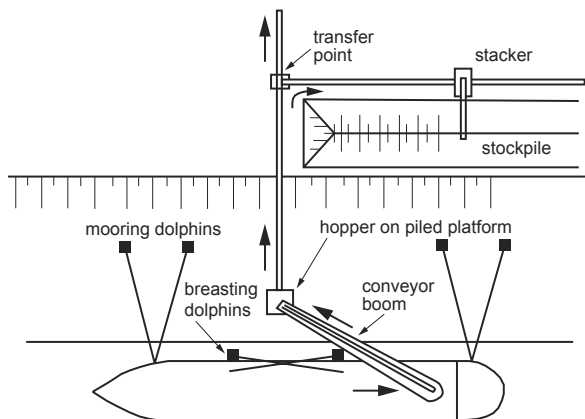

Figure 11.1 Dolphin berth for self-unloaders

These *self-unloaders* originate from the coal trade on the big lakes in the USA, but are more widely used now in different parts of the world for the shorter transport distances (coal from Sumatra to Java) or for through-transport from a main port to a temporary terminal. The advantage is that no shore cranes are required, but particularly that a simple dolphin berth (instead of a continuous marginal quay) is sufficient to berth the ship, even in case of very wide slopes (see Figure 11.1). The disadvantage is that the ships are more expensive per tonne capacity and more vulnerable to mechanical breakdowns, e.g. a broken conveyor

belt is difficult to repair in the confined space at the bottom of the ship. For smaller required capacities, the short sea traders are used, also called coasters. They have the advantage of being able to visit virtually all ports due to their restricted draught. They are equipped for transport of bulk and general cargo and, usually, have their own unloading gear

For non-conventional bulk carriers, typical dimensions are given in Table 11.1

Table 11.1 Dimensions non-conventional bulk carriers

	self-unloaders	short sea traders
DWT [t]	20,000 - 70,000	300 - 3,000
L_{oa}	200 - 250	40 - 95
B_s [m]	20 - 30	5.5 - 13
D [m]	7.5 - 12.5	2.5 - 6

It is emphasized that the type of cargo (low or high relative density) is governing the actual draught of the carrier.

The actual draught, in its turn, controls the possibility to enter a port with restricted depth. Therefore, it is important to judge the most efficient -and economic- relation between:

- Types of commodities to be transported, and their bulk densities
- Type of carrier most suitable for that purpose
- Cargo combination possibilities
- Technical restriction of ports of call

11.4 Unloading Systems

11.4.1 General

There is a variety of unloading systems and equipment, some continuous, some discontinuous, and with a wide range of capacities. The main systems are:

- grabs
- pneumatic systems
- vertical conveyors
- bucket elevators
- slurry systems
- self-discharging vessels

The capacity of the unloading equipment is usually decisive for the throughput capacity of the terminal, as the capacities of other terminal equipment should be geared to that of the unloading facilities. However, there is confusion in defining *capacity*. The following three definitions are currently used in dry bulk terminals:

- i. *Peak capacity*, also known as *cream digging rate*, is defined as the maximum (hourly) unloading rate under absolute optimum circumstances: a full hold, an experienced crane operator and at the start of the shift.

This unloading rate has to be the *design capacity* of all down-stream plant and equipment: belt conveyors, weighing equipment and stackers. If not, it would give rise to frequent blockages and stoppages in the cargo flow. It is, therefore, of prime importance for the system designers and equipment suppliers.

- ii. *Rated capacity*, also known as *free digging rate*, is defined as the unloading rate, based upon the cycle time of a full bucket or grab from the digging point inside the vessel to the receiving hopper on the quay and back, under average conditions and established during a certain length of time.
- iii. *Effective capacity* is defined as the average hourly rate attained during the unloading of the entire cargo of a ship. The necessary interruptions for trimming, cleaning up, moving between holds, etc., are taken into account, but not the scheduled non-working periods, such as night time, weekends, etc.

The effective capacity multiplied by the annual operational availability of the berth times the permissible occupancy rate gives the *annual berth capacity* which is the main parameter for the port planner. In other words, whereas the *equipment designer* is primarily interested in the peak capacity, the *port planner's* interest is in effective capacity.

For the grab unloading system, the different capacities relate about as follows:

- Peak capacity 2.5
- Rated capacity 2.0
- Effective capacity 1.0

For the *continuous unloading systems*, the differences are smaller, but vary considerably from one system to another. For example, a mechanical chain unloader for raw tapioca still requires trimming and cleaning up in the hold, which results in a large discrepancy between rated and effective capacity, but self-unloading vessels can maintain the rated capacity over almost all of the unloading time.

To add to the confusion, port authorities, in their marketing efforts, at times use a 'maximum berth capacity' or sometimes simply called berth capacity, which is the effective capacity, but calculated for a 100% occupancy rate. Such figures have no real significance because in those conditions, a tremendous congestion would develop and the port or terminal would be out of business in a very short time. In the following, the main unloading systems will be discussed.

11.4.2 Grabs

The grab, normally, is used for picking up material from the vessel hold and discharging it into a hopper located at the quay edge, feeding onto a belt conveyor (see Figure 11.2).

The attainable handling rate for a grab is determined by a number of factors, such as hoisting speed, acceleration of the grab bucket, travelling speed, horizontal and vertical dis-

ces, closing time of the grab, skill of the operator, the properties of the material being handled, shape and size of cargo holds, and cleaning requirements. Mechanical restrictions and operator fatigue restrict the number of crane cycles per hour that can be attained to about 60, though 40 is closer to a normal average. The payload deadweight ratio of the grab bucket affects the net production; the normal ratio is 1:1, but new designs are approaching 2:1.

A bulk cargo terminal for a range of commodities will require a set of 2 or 3 grab buckets per crane (one in use, one on standby and/or one in repair). Commodities with significantly different physical characteristics need an additional set of grabs. The types of grabs vary considerably, depending on the product which has to be handled. The principal materials handled often by grab are iron ore, coal, bauxite, alumina and phosphate rock. Smaller, mobile, grabbing cranes deal with raw sugar, bulk fertilizers, petroleum coke and varieties of beans and nutkernels.

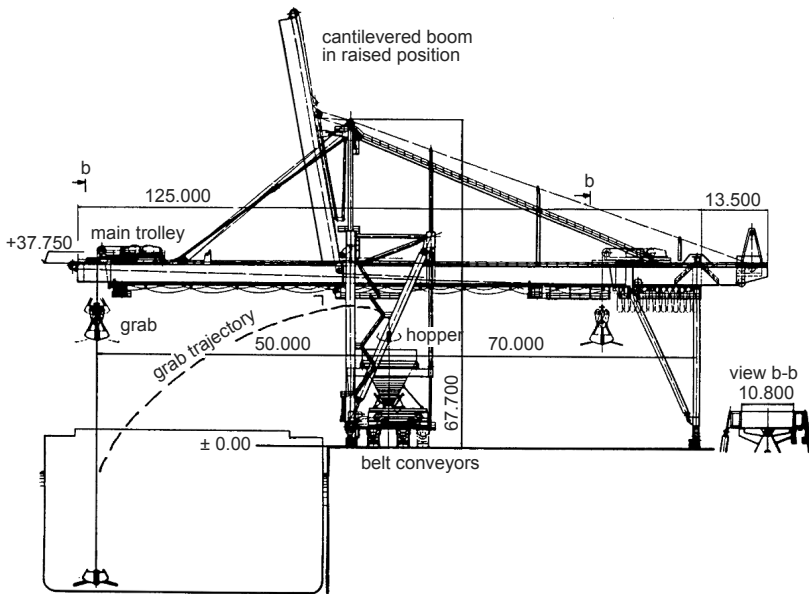

Figure 11.2 Heavy grab ship unloader by PWH with 85t lifting capacity. The unloading capacity is 4,200 tonne per hour on coal

Another type of grabbing crane different from the already mentioned overhead trolley crane, is the *revolving grabbing crane* (see Figure 11.3).

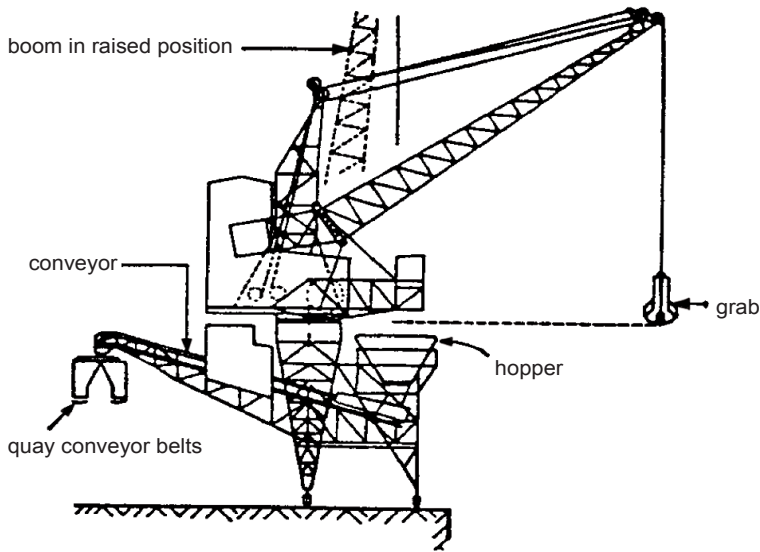

Figure 11.3 Revolving grab crane

Here, the grab lifts the material and discharges it into a hopper at the front to eliminate slewing during operation. The hopper feeds a conveyor or it can discharge directly into trucks or railwagons. Lifting capacity of a grab goes up to 85t.

Typical ranges of rated capacities are:

- Travelling overhead trolley grabbing crane unloader 500 - 2500 tonne/hour
- Revolving grabbing crane, lifting only 500 - 700 tonne/hour
- Revolving grabbing crane, with 90° handling 200 - 250 tonne/hour

(Occasional lower and higher capacities occur). Based on measurements, Tata Steel (ex-Hoogovens) in IJmuiden distinguishes the unloading process in three stages with decreasing productivity as indicated in Figure 11.4.

11.4.3 Pneumatic Systems

Pneumatic equipment is classified into:

- *Vacuum* or *suction types* (from several places to one spot)
- *Pressure* or *blowing types* (from one spot to several places)

Bulk cargo with low specific gravity and viscosity, e.g. grains, cement, powdered coal, fish, fish-meal, etc., may be handled by pneumatic systems. A disadvantage of the pressure type is the dust problem.

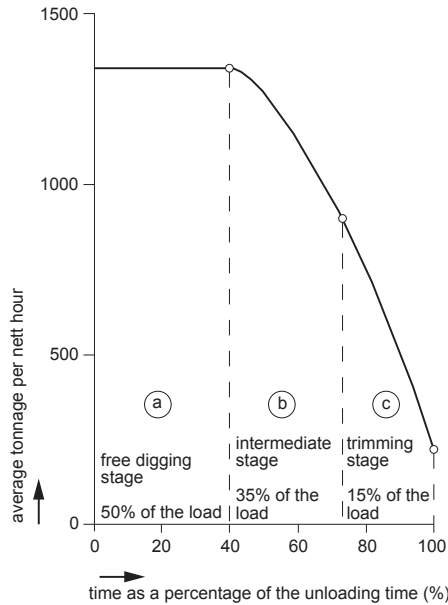

Figure 11.4 Unloading rate as a function of unloading time

The construction of vacuum pneumatic conveyors is simple, and there is no spillage of materials during transport. However, the power consumption is high, compared with other transporting systems.

The pneumatic elevator can be:

- Quay-based (see Figure 11.5)
- Floating (mounted on a pontoon)

Typical unloading rates (rated capacity) are in the 200 to 500 tonne/hour range, but capacities as high as 1,000 tonne/hour occur. In case of relatively small throughputs and/or non-dedicated terminals, portable pneumatic equipment may be used with a capacity of about 50 tonne/hour. More than one unit may be used at a time, serving different holds (see Figure 11.6).

11.4.4 Vertical Conveyors

Different types of vertical conveyors for unloading purposes are:

	<i>typical rated capacity</i>
Chain conveyor	200 t/hr
Vertical screw conveyor	900 t/hr
Spiral conveyor	75 t/hr

11 Dry Bulk Terminals

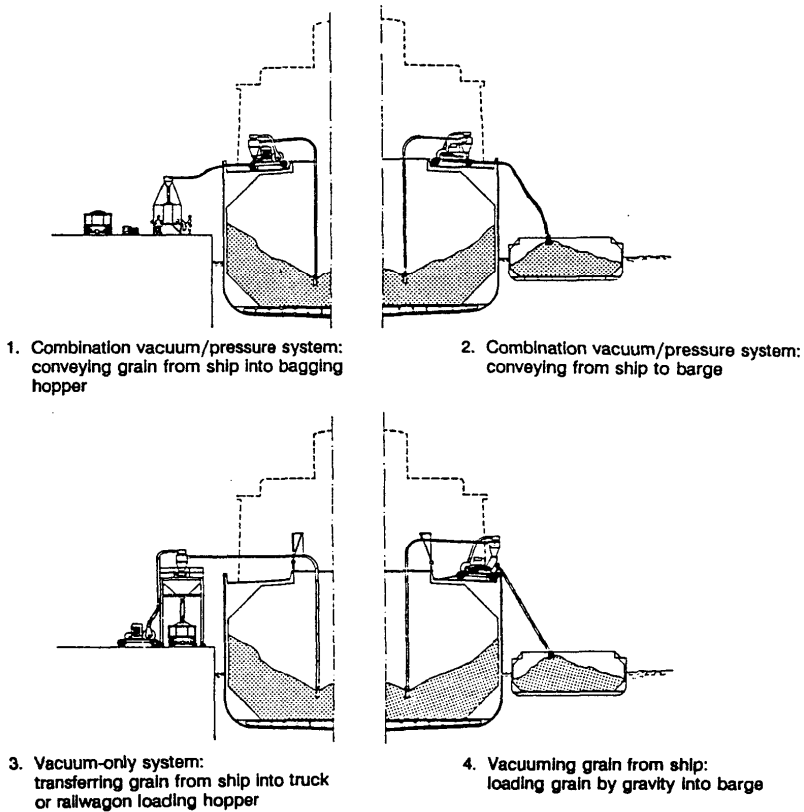

Figure 11.5 Portable pneumatic handling equipment

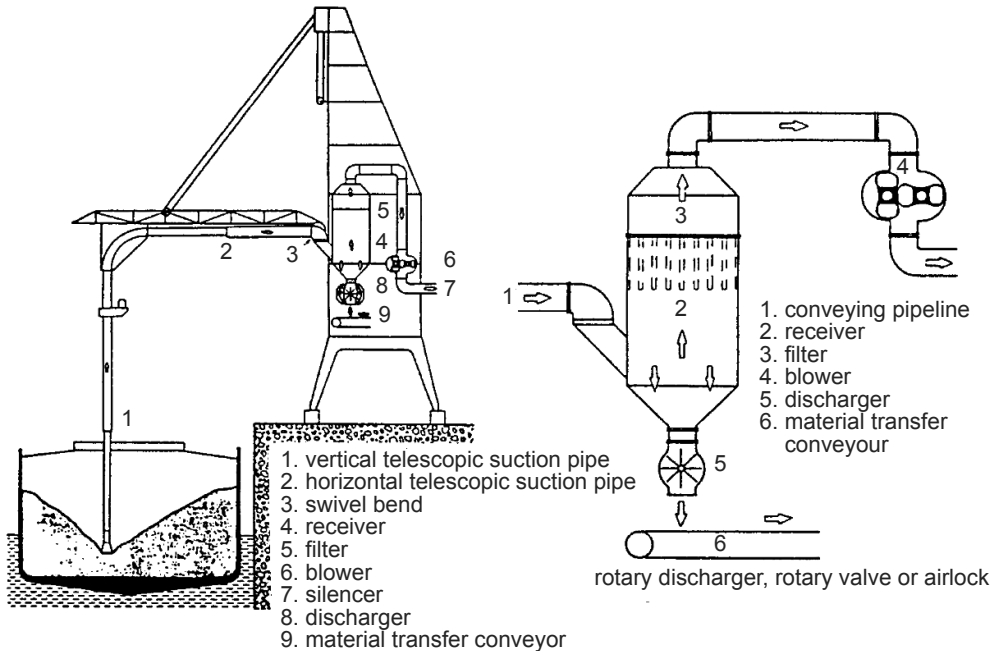

Figure 11.6 Pneumatic suction conveying system for ship unloader

The *chain conveyor* is usually built inside a rectangular casing, whilst the *vertical screw conveyor* (see Figure 11.7) is a full-blade screw contained in a tubular casing. Transport by chain conveyors is restricted to dry, friable materials, whilst the screw conveyor can deal efficiently with fine-powdered and granular materials, suitably sized lumpy materials, semi-liquid materials and fibrous material. The throughput is restricted to the rate at which material can freely flow into the feed aperture.

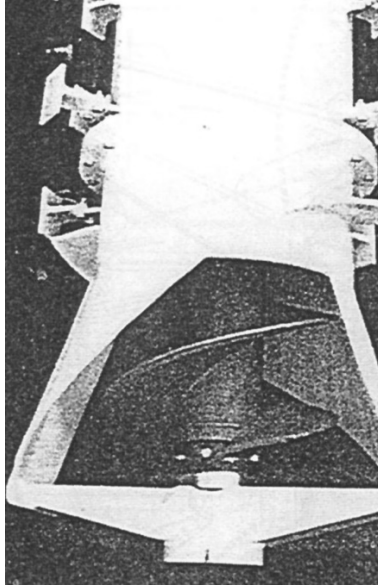

Figure 11.7 Feeder for coal with collecting vanes and digging blades

For unloading or loading of bulk (in bags or boxes), a vertical spiral conveyor may be used (see Figure 11.8).

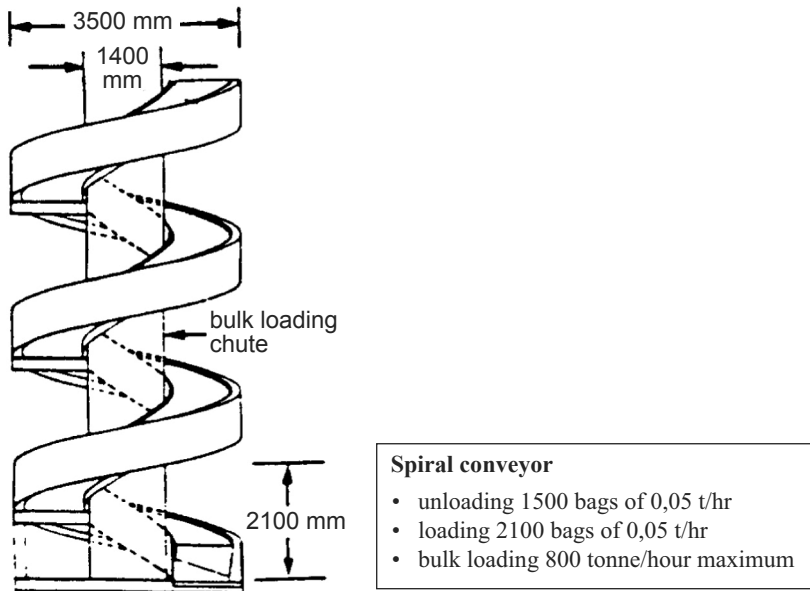

Figure 11.8 Spiral conveyor

11.4.5 Bucket Elevators

A bucket elevator consists of a continuously rotating bucket wheel, suspended from the luffing boom of the travelling unloader. This bucket wheel digs up the material and feeds a continuous bucket elevator. The quay has to be constructed to withstand the dynamic digging forces and the weight of the structure of the equipment. Alternatively, a bucket chain elevator can be used, with the buckets acting as digging scoops. As in the case of the wheel elevator, the bucket elevator is suspended from the luffing boom. Often, still the full hold of a ship cannot be covered whilst the different travelling, luffing and slewing motions to be performed during unloading make the equipment mechanically vulnerable (see Figure 11.9)

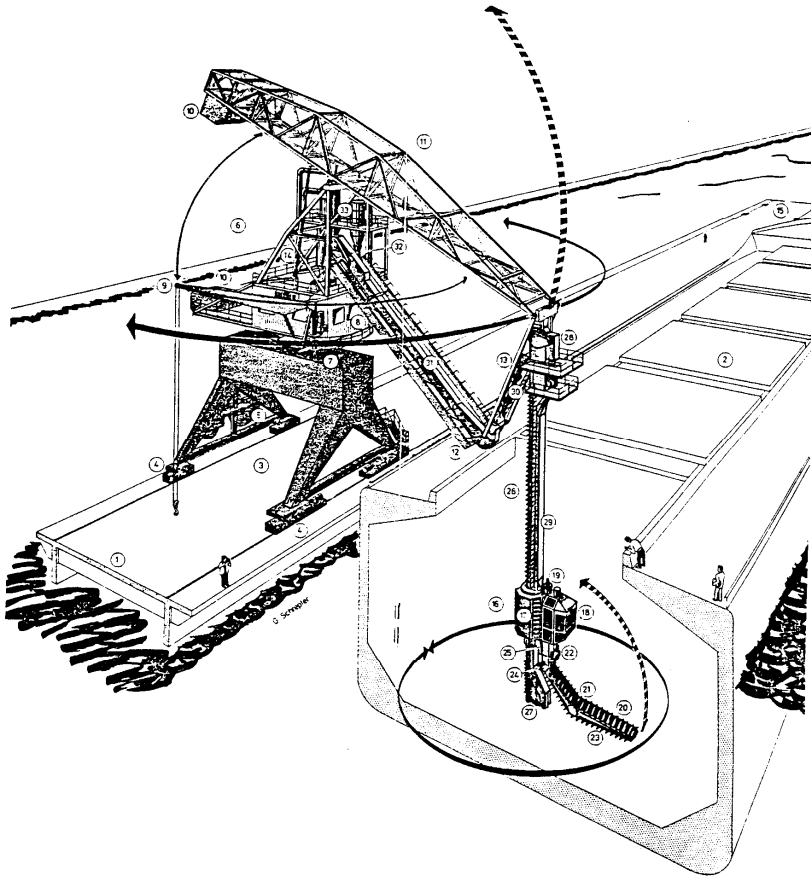

Figure 11.9 Movements of a continuous unloader

Maintenance costs of bucket elevators may be considerable. In terms of cost per tonne unloaded, they appear to be less efficient than grabs, taking into account the total capital expenditure and the operating costs. However, the free digging rates of the biggest unloaders built to date are around 5,000 t/h, against about 4,000 t/h for a grab system.

A bucket elevator has the following functional features:

- The bucket elevator assembly is always held vertical for easy operation due to the application of the parallel link (pantograph) motion.
- The bucket elevator can rotate freely to enable high unloading efficiency and easy operation.
- The swing-out and catenary mechanism of the bottom half of the elevator are provided for easy access of material under the hatch overhang and for efficient clean-up operation.
- An L shaped configuration can be made by swinging the elevator 90° at the second sprocket wheel for digging the bottom layer (see Figure 11.10).
- The elevator, the boom conveyor and the transfer points are totally enclosed to eliminate dust.

11 Dry Bulk Terminals

- Variable speed control of the bucket elevator can be provided for handling materials with different densities.

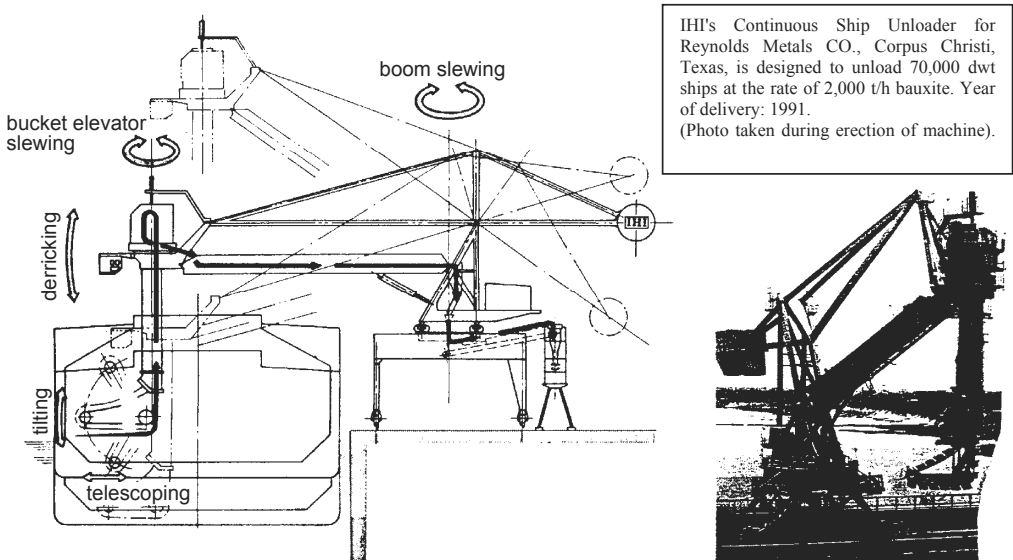

Figure 11.10 General arrangement and main operating functions of IHI's continuous unloader

In some designs for free flowing material, the buckets are attached to a steel wire which is pulled over and through the cargo (see Figure 11.11). In other installations, the digging function is performed by a bucket wheel that unloads onto a vertical conveyor (see Figure 11.12).

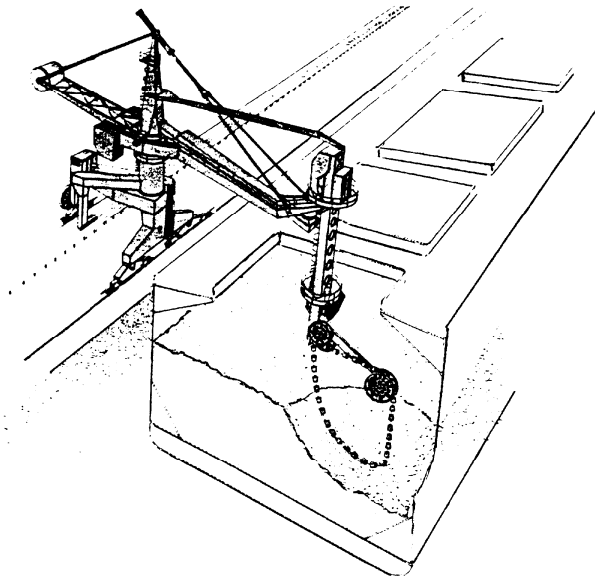

Figure 11.11 Continuous unloader with 762 mm buckets supported by a revolving crane. Enclosed elevating, dumping and take-away design with integrated dust collecting system

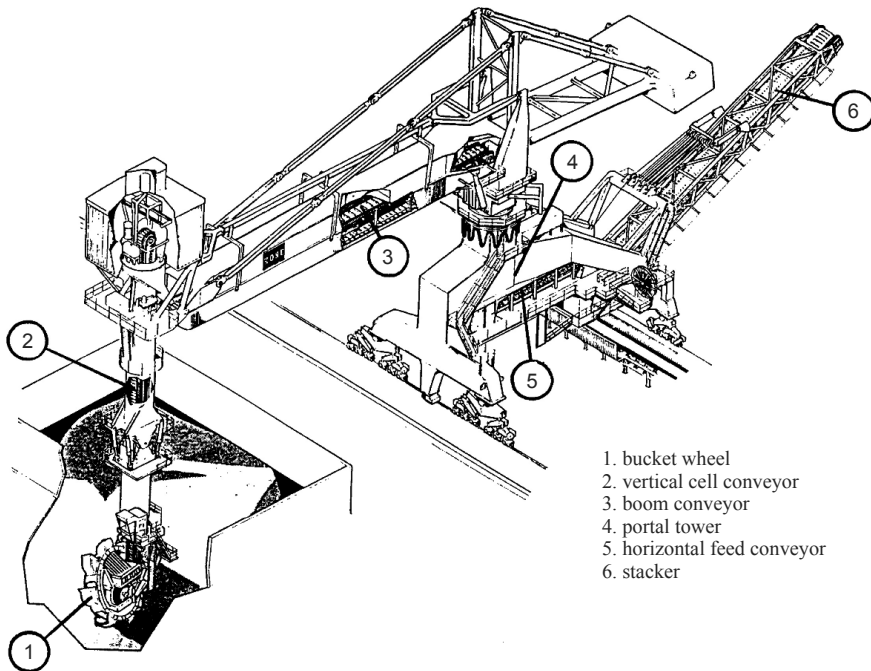

Figure 11.12 Design of the continuous bulk unloader

11.4.6 Slurry Systems

Ore and coal, after mixing with water, can be transported as slurry. But, so far this form of bulk transport did not yet find a very wide application. *Coal slurry pipelines* occur in the USA for the land transport of coal to powerplants and, e.g., in India for iron ore to a pellet plant. To limit pumping velocities, and thus transportation cost, the coal or ore has to be ground very fine, which gives problems for the later de-watering. The lower limits of transport distance and transport quantities for economic viability appear to be in the order of 50 km and 5 million t/y respectively.

In the maritime transport, it is the *Marcona Corporation* which has pioneered the slurry system, using vessels from 50,000 t to 140,000 t, a.o. for the transport of iron ore from Australia to Japan. But, worldwide the maritime transport of slurries is only a small fraction of the total bulk transport.

One of the difficulties is the environmental problem posed by the slurry water. In case of land transport, the slurry water, after the de-watering process, can be returned by separate pipeline for re-use. But, when loading a ship -for economic reasons-, the slurry is transported in the form of about 85% solids and 15% water-, the excess water generally will have to be collected and treated to avoid serious water pollution. This is expensive and also technically difficult.

At the unloading terminal, water jets have to be used in the ship's holds to bring the solid matter again in suspension, which is necessary for pumping. Before use in power plant or

blast furnace, the slurry must, once again, be de-watered to an acceptable low water content of 10% or less. This can be done for not too fine materials in settling ponds, and otherwise by filters, cyclones or thermal drying. Whatever process is selected, there is, once again, the problem to get rid of the polluted excess slurry water, which explains the limited application of the slurry system till the present.

11.4.7 Self-unloading Vessels

A discussion of these vessels and some of their advantages and disadvantages has already been given Section 11.3. A more complete listing of these advantages and disadvantages is given hereafter.

Advantages

- Reduction in voyage times due to high unloading rates (up to 10,000 tonne/hour and over for iron ore and large vessels).
- *Multi-port discharge* because no -or only very simple- shore-based unloading equipment is required.
- *Cargo blending*; cargo of different qualities, requiring blending, can be loaded in separate holds and blended into the conveyor belt system.
- Ship discharging flexibility: direct to stockpiles
 - into hoppers located on platforms offshore
 - into other vessels
 - into warehouses or silos with a rooftop access
- Environmental and pollution control; stringent requirements can be met.
- Simple and cheap berth structure; a few dolphins will do.
- No *stevedoring assistance* required

Disadvantages (as compared to conventional bulk carriers)

- Higher capital cost of vessel (about 15%), leading to higher tariffs.
- Higher crew costs; specialized unloading experts required
- Lower carrying capacity; the self-unloading equipment takes space.
- Greater mechanical vulnerability and, thus, higher downtime.

11.5 Loading Systems

The loading of bulk cargo is virtually always a continuous process in which one or more movable ship loaders are fed by a belt conveyor system from the stockpile and drop the cargo in the different holds of the ship. In case of dry and dusty products, the ship loader will have to be provided with a telescopic or spiral chute to reduce drop height and fall velocities.

Load capacities vary from a few thousands t/h to 20,000 tonne/h (Tubarao, Brazil). Particularly for the very large loading terminals, receiving big bulk carriers and requiring great water depths, the selection of location, terminal layout and loading system should be a joint effort of mechanical and civil engineers as the respective problems are very much inter-related.

The most common ship loader is a travelling crane on a quay wall or jetty, to which the ship is berthed (see Figure 11.13). But, as for large bulk carriers quay walls of some 300 m length are required, with a great retaining height, the civil sub-structure becomes relatively expensive.

For that reason the so-called radial and linear shiploaders have been developed, which are less expensive in terms of substructure (see Fig 11.14).

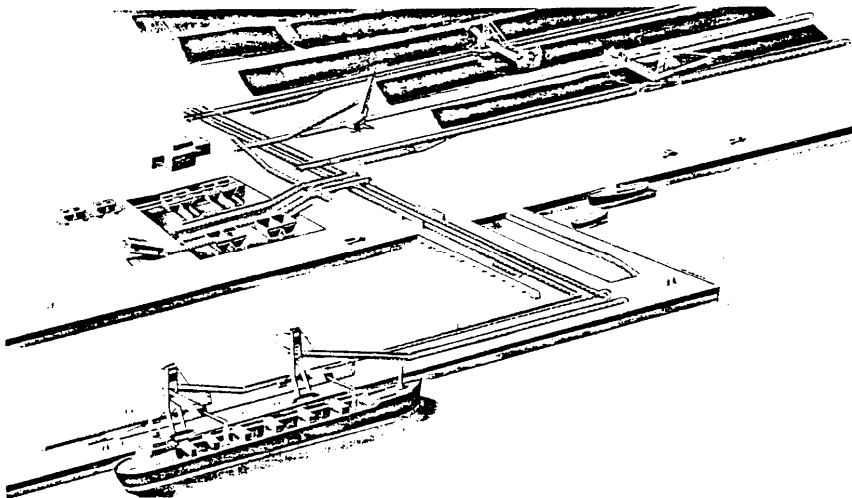

Figure 11.13 Loading terminal

For that reason, the so-called radial and linear ship loaders have been developed, which are less expensive in terms of sub-structure (see Figure 11.14).

Linear loaders

The bridge of the loader rotates around a pivot, and is supported by this pivot and by a straight rail track parallel to the ship. Apart from rotating, the bridge also travels longitudinally across the pivot. Due to this combined movement, the frontside of the bridge moves parallel to the ship's side. In order to reach the holds of the vessel, a loading boom with horizontal and vertical motion is connected to the bridge.

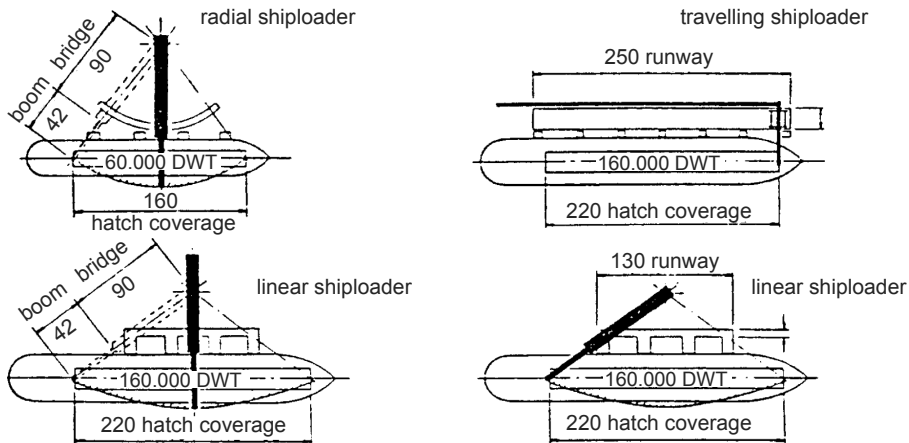

Figure 11.14 Ship loaders

Radial loaders

The bridge of this loader also moves around a pivot, but is supported at the other end by a circular track. A telescopic loading boom is attached to the bridge. This boom can reach all the holds of the ship which is berthed at a number of dolphins placed in one line. An alternative to this system, allowing the ship to head in different directions, has the dolphins placed in a circle segment, or provides a buoy mooring for the ship. The latter solutions are used for unsheltered terminals to minimize wave effects.

11.6 On-terminal Handling and Storage

11.6.1 Transport Systems

Transport systems are required to bring the cargo from the quayside to the storage area(s), and vice versa. These storage areas can be in the open air or under cover in sheds or silos. This transport is mostly effectuated by conveyors, but occasionally by cable ways -a looped steel wire with buckets-, special rail cars or off-highway trucks. Here, the discussion will be restricted to conveyors.

Most conveyors are belt conveyors which are widely used for handling of dry bulk. In theory, unlimited distances can be covered, but the use of conveyors is generally restricted, for transport-economic reasons, to a few kilometres. For longer distances, rail or road transport often becomes more appropriate, although belt conveyors of more than 100km occur, e.g. for the transport of phosphate from mine to port in Morocco.

Advantages of the belt conveyor system are:

- Simple construction
- Economy of maintenance
- Efficiency, with low driving power requirements
- Adaptability

- Complete discharge of handled materials

A disadvantage is the limited vertical angle at which normal belt conveyors can operate. A substantial difference in height requires a considerable amount of space.

Conveyor belts for bulk materials are troughed; flat belts are used for packaged materials. For special applications, so-called pipe conveyors and hose belt conveyors have been developed (see Figure 11.15). These are essentially normal troughed conveyors which beyond the loading and off-loading points are folded into a U-shape which, first of all, results in an enclosed, dust-free system, and, in the second place, allows rather narrow curves and steep gradients to be introduced. For the conventional straight conveyors, transfer of cargo from one belt to another occurs at transfer points, which for dusty commodities have to be enclosed (see Figure 11.16). In view of more stringent dust control requirements many modern dry-bulk terminals have the conveyor belts covered over the full length.

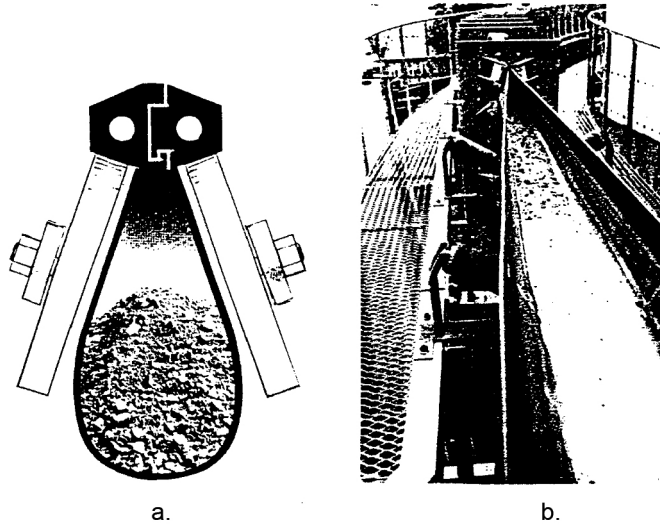

Figure 11.15 a. Aero-bande system b. Tokai system [source: Bulk Solids Handling]

11.6.2 Stacking, Storage and Reclaiming

Stockpiles must be planned in such a way, that a maximum amount of material can be stored on a minimum area. The possibility thereto depends on the bearing capacity of the subsoil, the characteristics of the materials and on the outreach and height of stackers and reclaimers.

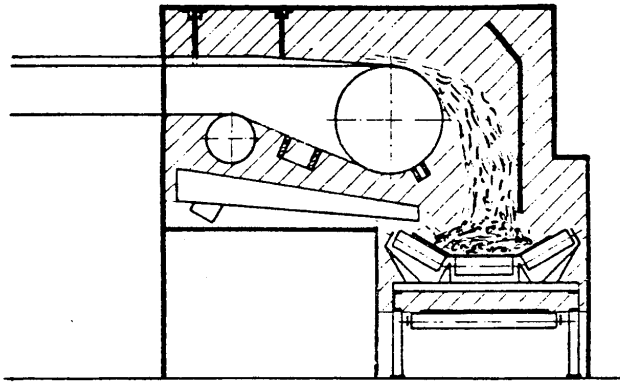

Figure 11.16 Enclosed transfer point

If weather conditions may affect the quality of the material, a covered storage will be required. The feed-in generally takes place from a high belt conveyor, situated along the apex of the building, and reclaiming occurs by means of a scraper/reclaimer or underground conveyor (see Figure 11.17).

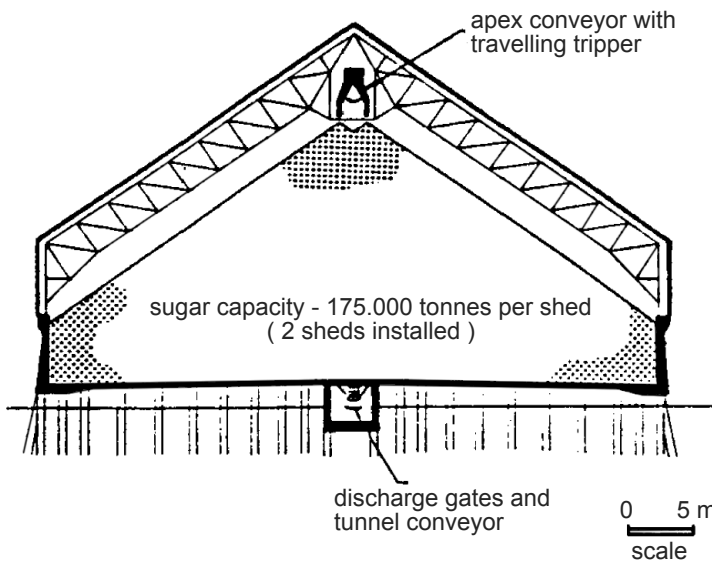

Figure 11.17 Storage shed

The area required for stockpile depends on the following factors:

- Height and shape of stockpiles
- Size of shipload distribution
- Ship arrival distribution
- Through-transport distribution
- Ship loading and unloading rates
- Strategic reserves to be maintained

- Relation gross net area

Both the ship arrival distribution and the through-transport distribution, in addition to normal stochastic fluctuations, may well show seasonal fluctuations. Therefore, no general rules apply, and area requirements have to be calculated according to the specific project conditions.

Bulk commodities must often be segregated according to their properties. For unloading terminals, each stockpile must be able to accommodate at least a full shipload from each source.

When using motor trucks or railcars for transport from ship to storage, it may be convenient to use a storage bunker or truck silo in conjunction with the open storage. Special care must be taken to avoid segregation of *free-falling material*, entering an empty bunker. Specially designed spiral chutes arrest the free fall of the material.

The equipment used for bringing the bulk cargo into storage are the so-called stackers, whilst for retrieving material from the stockpile *reclaimers* are used. Stackers are travelling machines with a stacking boom with belt conveyor. Transfer of the bulk material from the main transport conveyor onto the stacker conveyor occurs by means of a tripper (see Figure 11.18) which is attached to the stacker and, thus, can move back and forth along the stockpile. (Note: a tripper is also used in a travelling loader).

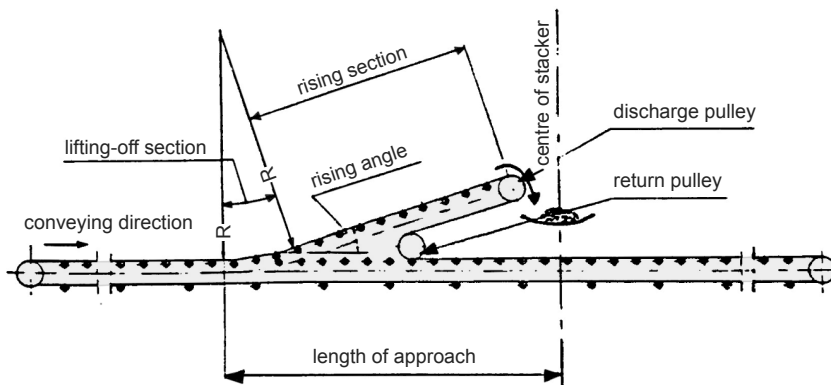

Figure 11.18 Principle of belt loop or tripper

Reclaimers are similar travelling machines, but equipped with a reclaiming device, e.g. a bucket wheel, and an intermediate belt conveyor. Sometimes, bulldozers are required to push parts of the stockpile within reach of the reclaimer.

Often, the capabilities of stacking and of reclaiming is built into one and the same machine, which results in the well-known *stacker-reclaimers* (see Figure 11.19).

The above equipment is virtually all bulky and heavy, and requires sturdy and heavy crane-track foundations.

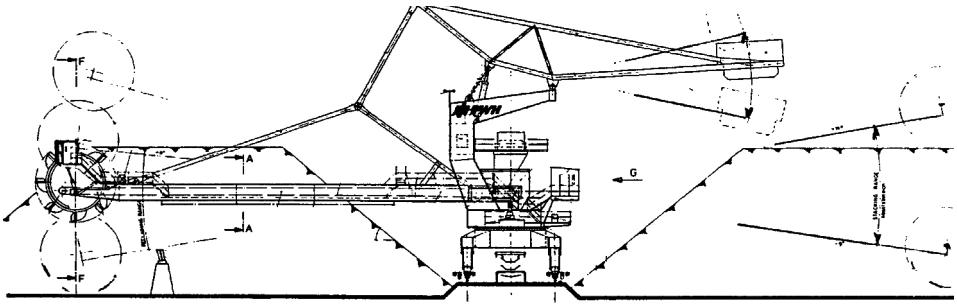

Figure 11.19 Stacker-reclaimer

11.6.3 Blending, Processing, Weighing

Particularly for iron ore and coal, blending of different grades is often required before delivery to the powerplant or steel industry, with rather strict requirements of the homogeneity of the mix. The desired result can be achieved by specific stacking and reclaiming methods. For example, the stockpile may be built up in longitudinal layers of different grades, whilst reclaiming is effectuated by transverse scraping drum reclaimers. A great variety of tailor-made solutions may be found in different terminals around the world.

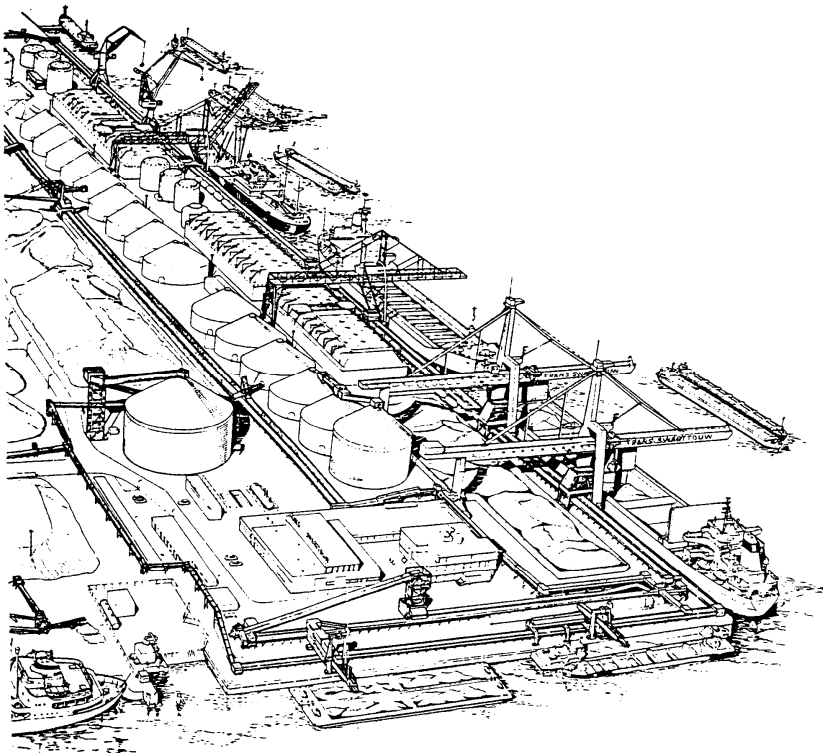

Figure 11.20 Rotterdam Bulk Terminal, Vlaardingen

Processing of dry bulk is limited in port terminals. It is mostly restricted to bagging of grains, sugar, cement and similar products.

Bulk commodities must often be weighed immediately prior to loading or after unloading, for payment purposes or for checking against shipping documents. *Batch weighing methods* are employed as well as *continuous weighing* of the material on a moving belt conveyor. Sampling is sometimes required to satisfy the customer. For obtaining a correct composition of a particular batch, it is essential to take a series of samples automatically at timed intervals.

Figure 11.20 gives a bird's eye view of a modern multi-product bulk terminal.

11.7 Design Aspects of Dry Bulk Terminals

A first order estimate of total length and width required for the stockpiles can be made with the following simple equation:

$$V = b \cdot \frac{1}{2} \cdot h \cdot l \cdot m_b \quad (11.1)$$

in which:

- V = maximum volume of cargo in storage
- b = width of stockpile
- h = height of stockpile
- l = total length of stockpile
- m_b = utilisation rate

In this calculation the angle of repose of the bulk material is taken at 45° and the shape of the pile is cross-section triangular. In reality the angle of repose will vary between 35° and 40° and the pile cross-section may be trapezoidal (depending on the design of the equipment).

11.8 Climatic and Environmental Considerations

The climatic conditions prevailing at the terminal location may influence the planning of the stockyard operation to a great extent. In very cold areas, special low temperature steel has to be used for the construction of the reclaimer equipment, gears have to be heated, and one has to cope with high cutting forces in frozen material. In rainy seasons, some materials require covered storage.

The same is true where the environment must be protected against dust and noise. Environmental considerations begin to play an ever increasing role. As a result, provisions like a waterscreen at hopper openings, fully enclosed conveyor belts, no-spill grabs and partly or fully enclosed storage are common practice at new installations. For coal terminals it becomes good practice to spray the piles with water, to keep the dust down. The spray-water is collected by a drainage system, cleaned and reused.

Finally the planners and designers of dry bulk terminals and their hardware should be well aware of safety aspects, in particular the risk of dust explosions. There is quite a history of such dust explosions with major damage to terminals and extensive loss of life. Coal dust and grain dust are probably the most susceptible, but even cement and bauxite dust are explosion prone. A dust explosion resembles a gas explosion, but is usually relatively much stronger. This is because the primary explosion causes a dust-laden whirlwind in adjacent areas with a chain reaction as result. The nature of risk reducing measures depends on the product handled.

11.9 References

Ocean Shipping Consultants, Self-discharging bulk carriers - a market study, 1991
UNCTAD, Port Development, United Nations, 1985
Wöhlbier, R.H. (ed), The best of bulk solids handling, 1981-1985, Transtech Publications, 1986

Chapter 12

Fishery Ports

12.1 Introduction

Over the years, fish has gained importance as a source of food (protein). While fishing in many waters is restricted by quotas, most developing countries bordering the sea are -and will be- looking for ways to create or improve their fisheries and are, therefore, involved in fishery port development.

A fishery port can comprise, in addition to the unloading, handling and marketing of fish through a specialised terminal, industrial areas where fish is processed, and also service and maintenance facilities for vessels, nets and gear.

Most fishing activity is dependent on the availability and nearness of fish, and is also seasonally influenced. Therefore, the fishing activity shows peaks and lows with either the majority of the fishing fleet at sea or almost all of the fleet resting at the port.

It is advisable to separate fishery activities from commercial port activities. First of all, for reasons of nautical safety, small-craft traffic, including the movement of fishing vessels, should be kept away from deepsea ports as much as possible. Secondly, waterdepth requirements and, thus, basic design criteria are totally different for the two types of ports. Thirdly, the smell of a fishing port will often not be acceptable in commercial ports, whilst, reciprocally, the fishery products may become contaminated by e.g. ore dust. Fourthly, the type of operations, the equipment used and the mentality of the people running the ships and the terminals are so different that they do not fit very well under one and the same umbrella.

12.2 Types of Fishery Ports

Fishery ports can be distinguished according to the purpose they serve, e.g. as follows (FAO, 2010):

12.2.1 Simple Landing Places

They serve fishermen, bound to a certain location, generally operating on fishing grounds at a short distance away. It may be that such landing places can hardly provide any natural

shelter for beaching and launching of vessels. Sometimes, protection is available when the landing place is located in bays, rivermouths, estuaries and the like. In order to improve the effectiveness, the landing place should provide a ramp or small berthing quay, together with simple facilities for handling of the catch. The provision of some services and facilities for maintenance and repair will increase its value.

12.2.2 Coastal Fishery Ports

Table 12.1 Coastal fishery characteristics and required functional facilities

Item	Characteristics	Required facilities	Comments
Facilities for catches	one by one, then auctioned off. Different types of fish are lined	Handling sheds	
	Fish is kept fresh, packed in ice and shipped off immediately.	Ice-storehouses (Freezer warehouses)	
	Seabream and other high-price fish are often shipped live.	Live fish-tanks	Special live-fish transport vehicles are necessary to convey live fish to consuming district.
Facilities for fishing boats and gear	Storage warehouses and repair areas will be necessary when nets and similar fishing gear items are used.	Fishing gear warehouse Fishing gear drying area	
	When located away from neighbour ports, the need will exist for fuel oil supplies at home port.	Oil storage tank (Oil supply equipment)	
	For small boats, it will be easier to use the slipway than the wharf. It will also be possible to perform maintenance and repair work, such as barnacle removing and painting.	Slipway	
Facilities for people	Areas for gathering, discussions, training and other activities by local people are a must.	Fishing village centre	
	Fishermen's unions are organized to ensure smooth fisheries operations.	Fishermen's cooperative office	

These are the home-base for small coastal fishing vessels up to some 20 m in length. Fishing grounds may be a bit further away, requiring trips of a few days' duration. The vessels are equipped with somewhat more sophisticated gear and equipment, compared with those of the first mentioned group. Hence, more protection is required, and the provision of services, with the related infrastructure, should be more elaborate.

12.2.3 Near-distance Fishery Ports

These will frequently include a number of provisions, required by the smaller coastal vessels, but they are mainly meant for vessels with lengths from 25 m to 40 m. Fishery grounds may be several hundred miles away, requiring trips of several days to some weeks.

12 Fishery Ports

Vessels may be equipped with limited processing facilities on board, e.g. heading, gutting and icing in containers and, occasionally, with a chilling unit. Navigational aids and other mechanical and electronic equipment belong to their outfit. The ports must, therefore, provide the means to supply, repair and service these types of equipment in addition to the normal port services.

Table 12.2 Offshore fishery characteristics and required functional facilities

Item	Characteristics	Required facilities	Comments
Facilities for catches	Fish landed is sorted by type, boxed, auctioned, shipped.	Handling sheds	Catches are sometimes transported directly from the wharf by truck
	Large fish volumes mean large amounts of fish boxes required.	Fish boxes	
	Fish is handled fresh, with the great majority refrigerated or frozen after landing	Storage areas Refrigerators Freezers Cold storage Reefer vehicles	
	Parts of catches will be salted and dried, boiled and dried, canned or processed in similar fashion.	Processing plants	
	Processed products are temporarily stored in warehouses.	Processing products warehouses	
	Large amounts of polluted water will be stored in warehouses.	Waste water treatment warehouses	
	Large amounts of polluted water will be created by processing and handling areas	Waste water treatment facility	
Facilities for fishing boats and gear	Catches are packed in ice in transport ship storage bins for hauling to port.	Ice-making plants Ice-storehouses Ice supply equipment	
	Large amounts of ice are, thus, needed to preserve freshness.		
	Voyages vary from 1-2 days with extended trips 3 weeks in length. Steady supplies of fuel oil at stable prices are demanded.	Oil supply equipment Oil storage tanks	
	Net fishing gear may need to be repaired and stowed away.	Fishing gear storage and repair stations	
	Offshore fishing boats are comparatively large, with special facilities required for repairs.	Fishing boat repair station	
	Need to treat waste oil produced by fishing boats	Waste oil treatment plant	
	Facilities for people	Large volume and value of catches attract many fishmongers and middlemen.	Auction building Offices
Comparatively large size of offshore fishing port creates need for comprehensive port administration.		Fishing port administrative office	
Desirable to separate fishing port from the cities.		Park Greenbelt	
Public transportation to and from the port.		Park	Bus service

12.2.4 Ocean Fishery Ports

Table 12.3 Distant-water fishery characteristics and required functional facilities

Item	Characteristics	Required facilities	Comments
Facilities for catches	Large catches: mechanical unloading.	Cargo handling equipment and storage space (mobile cranes, forklifts, conveyer belts).	sometimes done by ship's derrick crane
	Landed catches are auctioned, shipped.	Handling sheds	Catches are placed one by one
	Direct transfer to cold storage facilities in many cases	Refrigerating / freezing plant	-40°C to -50°C
	Processing done on board or in port where landed.	Processing plants	Need for treatment facilities. For resulting polluted process water
Facilities for fishing boats and gear	Fuel oil costs account for large percentage of fisheries costs, need for stable prices through storage.	Oil supply equipment Oil storage tanks	Ample oil storage capacity if space allows
	Long voyages create need for procurement of clothing, food, etc.	Clothing and food stores	Procurement from local shops in most cases
	Need for electric power supply from shore when boats docked in port.	Electric power outlets supplies used if adequate	Normal power and water
	Long voyages create need for large volumes of drinking water.	Drinking water outlet, etc.	
	Scrupulous repairs and checks are vital; boat or equipment breakdown at sea could mean disaster.	Fishing boat repair stations	Need for facilities including docks
	Need for information on shifting market prices to boats at sea. Weather reports are also vital.	Radio stations	
	Facilities for people	Boats carry 20-30 crewmembers, and travel long distances; family members often send off or greet fishermen when boats set sail or return.	Lodging
Health care for fishermen is vital.		Clinics	
High volume and value of products handled attract many traders and middlemen.		Offices, banks, auction building	
Ports are large which requires a comprehensive administration.		Fishing port administrative offices	
Surrounding areas are usually developed cities; desirable to separate fishing port from lifestyle activities.		Parks Greenbelt	
Public transportation to and from the port.		Bus service	

Such ports are used as home-base by the large, modern factory-type fishing vessels. These vessels are equipped to make long trips on the ocean, and they have a great flexibility as to the location of its homebase. When fishing at faraway locations, they may stop at ports of call for discharging purposes and for taking provisions. Sometimes, servicing takes place at advanced bases and even transshipment can be established to enable the vessel to remain a longer time on the fishing grounds. Processing of the fish takes place on board, such as deepfreezing, canning, etc.

¹Using a large fishing net that hangs vertically with floats and the top and weights at the bottom, the ends being drawn together to enclose fish as it is hauled aboard.

²Using a large wide mouthed fishing net dragged along the bottom of the sea.

The port has to be fully equipped to handle and maintain these types of ocean going vessels, and to deal with the large, but already processed catches. In consequence, normal commercial port facilities are often used by these vessels.

12.3 Site Selection

Generally, fishermen establish settlements near to existing fishing grounds, even if little or no natural shelter can be found for beaching and launching of vessels. If possible, a fishery port should be developed at a site where, in addition to favourable natural conditions, fishing activity already takes place. Fishermen are usually reluctant to change. Fortunately, fishermen usually settle in locations where some protection against nature is already available (bays, rivermouths, estuaries).

Table 12.4 Site information to be considered

Sea	Port	Land
Tides	Vessels	Access
<ul style="list-style-type: none"> ● amplitude ● type 	<ul style="list-style-type: none"> ● type, size and number ● peak landing volumes ● trend forecast 	<ul style="list-style-type: none"> ● road ● rail
Winds	Distance to fishing grounds	Settlement
directions		size
durations	Nearness to commercial ports	fishermen
storms		size
directions	Expansion possibility	labour
Waves		Available services
types	Natural shelter	water
height and period distributions		electricity
dominant directions		fuel
		workshops
Bathymetry		Topography
Areal photographs		Sub-soil profiles
Currents		Availability or nearness to
at different tide stages		construction materials
Sub-soil profiles		timber
		gravel
Coastal conditions		rock
littoral drift		sand
expected siltation, erosion		
dredging		

At potential sites for port development, surveys, including hydrographic, hydraulic, meteorological and sub-soil investigations, should take place. Table 12.4 gives an idea of the required information at each site. Some of this required information is common to all ports. Other items are specifically related to fishing ports. Preliminary lay-outs and cost estimates should be prepared for comparison. In an economic analysis, the expected catch volumes, the composition of the fishing fleet, distance to fishing grounds and to fish markets should be considered. Also, the presence of a labour force should be taken into account.

Fishing techniques change. Since in future developments bigger vessels may be introduced, it is advisable to select locations where later on a deepening of the port and its access from the sea appears technically and economically feasible.

12.4 Fishing Vessels

The fishing vessels, method and gear used, depend on the kind of fish caught, whether *pelagic* (close to surface, moves fast) or *demersal* (close to bottom, moves slowly) and, in general, on the state of development of the fishing industry in a country. The number and characteristics of the vessels as related to the catch determine the required facilities to be provided by the fishery port.

Small coastal vessels, with a length of 3 m to 15 m, operating with inboard or outboard motors, sails or rows, are mainly made of wood (nowadays also of reinforced plastic), whilst vessels from 15 m to 25 m length are, more often, made of steel. Hold capacity in this category is usually between 0.5 and 20 tonne, whereas the bigger vessels can go up to 60 tonne in special cases. Catches are substantially lower when fish is caught for direct human consumption in comparison with catches for processing into fishmeal. Draught of the former vessels is in the order of 1 m to 2 m, whilst the larger ones have draughts up to 3.5 m. Typical draughts are shown in Figure 12.1.

The fishing cycle of the smaller coastal vessels is 1 or 2 days, and up to a week for the larger vessels using ice of salt to preserve fish. Smaller vessels generally use gillnets, lines and traps for fishing, while the larger vessels make use of purse seining¹ or trawling². The use of ice onboard and boxing at sea is a measure for the state of development of the fishery.

Big coastal vessels, ranging from 30 m to 40 m length, have a draught up to 4.5 m, and can carry up to 500 tonne of fish, with 1 to 2 weeks autonomy. Usually, fish is refrigerated or iced on board. Some limited processing can take place onboard, like heading and gutting. Dimensions are given in Figure 12.2.

High-sea vessels, ranging in length from 25 m to 80 m, have up to about 3,000 tonne fish hold capacity and an approximately 1 month autonomy. Fish is iced, refrigerated, frozen or processed on board. Tuna vessels fall in this group. For dimensions see Figure 12.3.

Factory ships have tonnages and draughts similar to smaller commercial vessels, and are often supplied with fish by smaller vessels. Generally, these ships utilise commercial port

12 Fishery Ports

facilities, since the investment necessary for accommodating them in a fishery port is economically unattractive.

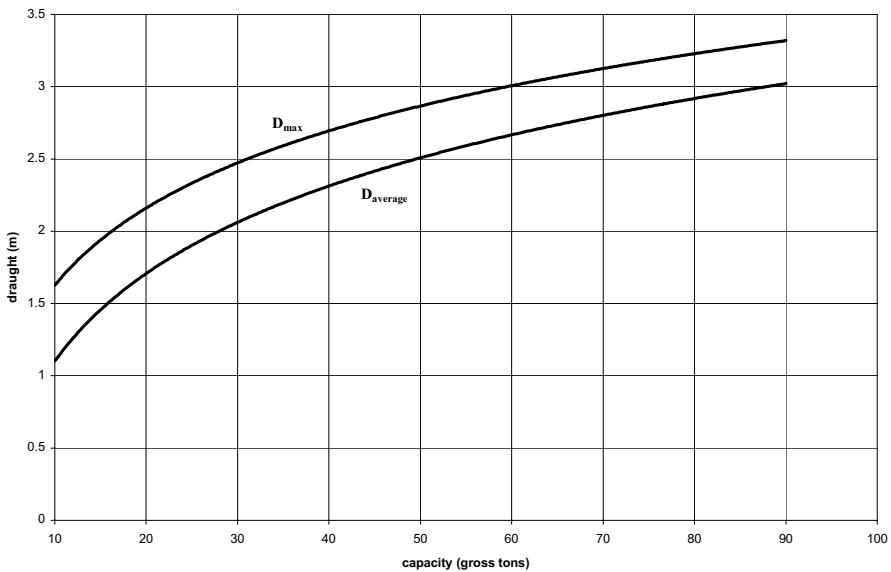
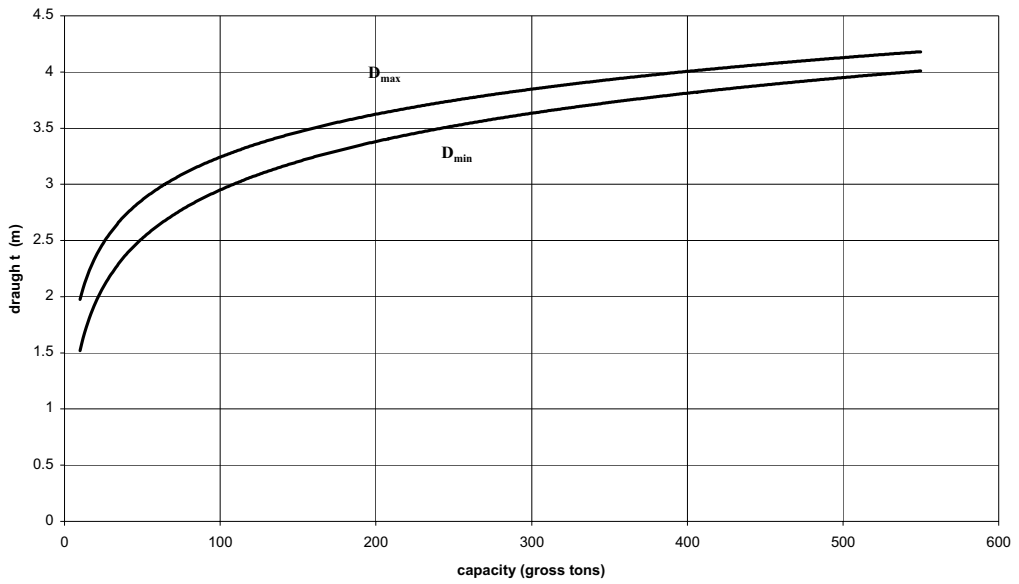

Figure 12.1 Small fishing vessel draughts

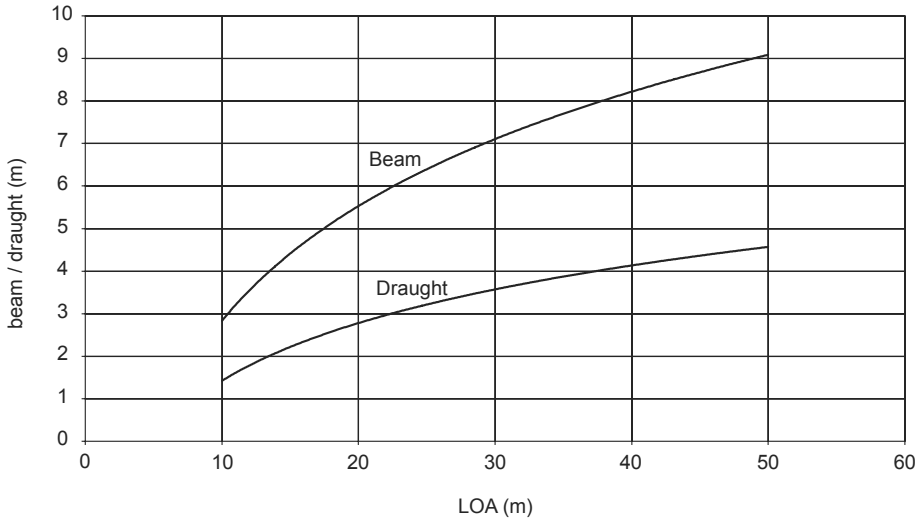

Figure 12.2 Beam and draught of fishing vessels

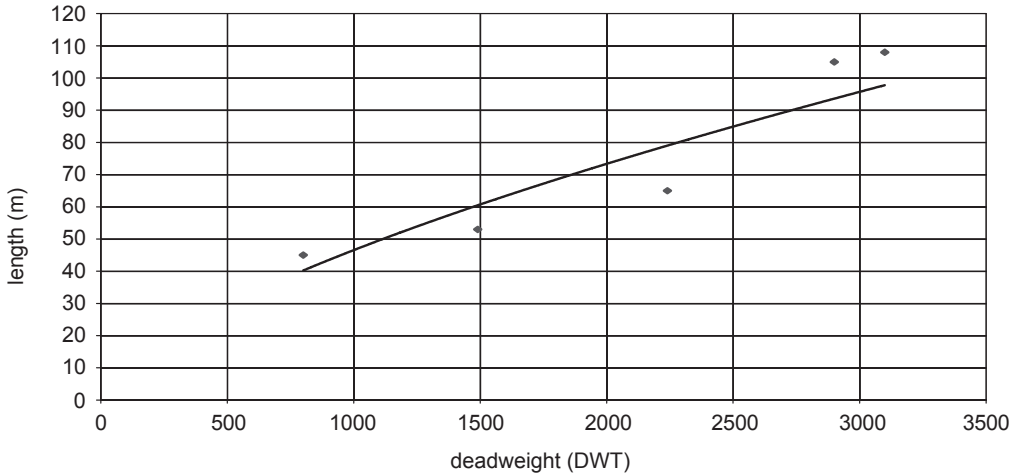

Figure 12.3 Length DWT relation for large Seiner vessels

The gross tonnage (GT) is commonly used to classify fishing vessels for administrative purposes. However, the method of the tonnage measurement differs considerably from country to country. 2.83 m^3 (100 cubic feet) of enclosed space is considered as 1 gross tonne. One method of calculating the gross tonnage is based on the *cubic number* of a vessel, which is the product of length, beam and depth. This method necessitates the introduction of a block coefficient (C_B) to take the streamline of the vessel into account. This block coefficient ranges from 0.5 to 0.65 for the smaller fishing vessels when the cubic number of the vessel is based on length overall. The gross tonnage then ranges from 0.18 to 0.23 times the cubic number.

As a first approximation, the following formula can be used:

$$GT = 0.2 \cdot L_{OA} \cdot B_s \cdot D$$

Figure 12.4 gives the average cubic number for trawlers and purse seiners.

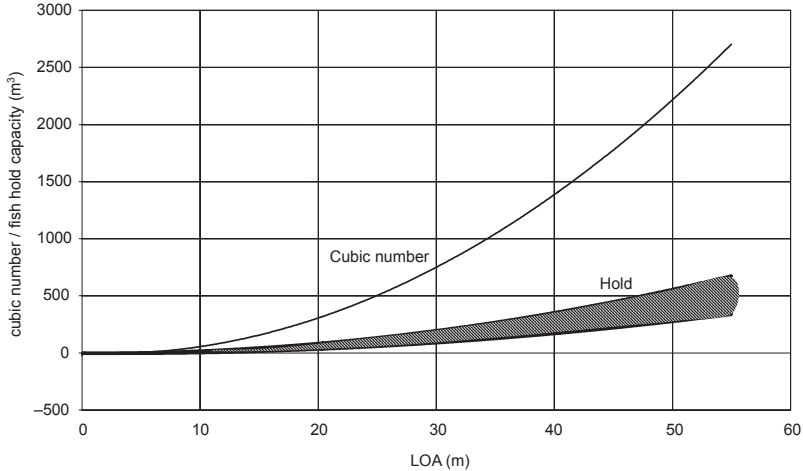

Figure 12.4 Cubic number and fish hold capacity of fishing vessels

The *fish hold capacity* of the various types of fishing vessels varies so greatly, that not even average figures can be given, but only average maximum and average minimum values. Figure 12.3 gives these averages for purse seiners and trawlers.

12.5 Port Planning

12.5.1 Access Channels

Width

Access channels should have a width in accordance with the required number of lanes. Figure 12.5 gives an idea of the required width for a two lane channel. Approach conditions to the port should be taken into account, regarding wave action, currents and wind and extra margins near hard obstacles like breakwaters. The channel width is also influenced by the ease and the accuracy with which a navigator can determine his vessel's position with respect to the centre line. As such, the width is effected by factors like the horizontal movement of channel marker buoys due to tidal and other currents.

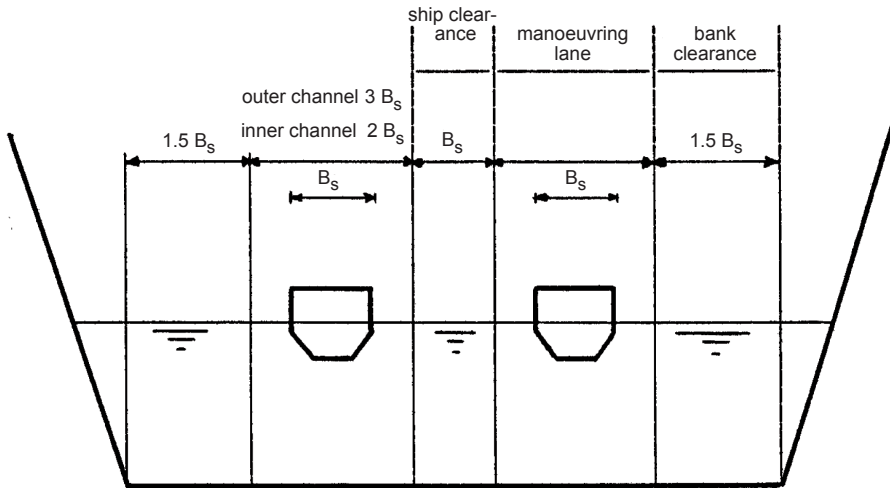

Figure 12.5 Channel width

An overall minimum value for a one lane channel width would be about 30 m to 40 m, applicable to small indigenous vessels and favourable nautical conditions. Widths for two-lane traffic vary from 90 m to 100 m. For an outer channel for two-way traffic, as a rule of thumb, the minimum width is about 10 times the beam of the maximum size vessel. For an inner channel, 8 times the beam of the maximum size vessel will do.

Depth

The minimum depth of an entrance channel is determined by the following factors:

- Maximum draught of the maximum size vessel
- Ship motions due to waves
- Variations in waterlevels due to tides and wind
- Sinkage of the vessel due to squat
- Minimum keel clearance
- Channel bottom topography
- Character of the bottom material (also of importance for side slope)

Reference is made to Equation (5.12). One should be aware that the wave response may vary greatly from one case to another.

12.5.2 Basins and Berths

Basin width

The basin width should be sufficient for easy manoeuvring and turning around of the biggest vessels (without tug assistance), while others are moored to the quays. This signifies that for a maximum ship size of 30 m, the basin width should measure approximately 160 m to 170 m, i.e. 5 L to 6 L.

The basin should provide unloading, resting, mooring, manoeuvring and servicing areas for the vessels.

Acceptable wave action at the berths

Acceptable wave action at the berths depends on height and period of waves, and whether vessels are berthed parallel or perpendicular to penetrating waves. For periods under about 6 s, small coastal vessels can be unloaded with a significant wave height H_s up to 0.3 m when berthed perpendicular to approaching wave crests, or about 0.15 m when berthed parallel.

Bigger vessels can be unloaded and serviced up to about $H_s = 0.5$ m and $H_s = 0.25$ m respectively, for abovementioned wave approach directions. For the latter vessels and wave periods over about 6 s, an H_s up to 0.3 m and 0.15 m for perpendicular and parallel berthing respectively, is acceptable.

Acceptable wave heights are given for normal unloading procedures with a small crane or derrick, and are not valid for special unloading devices.

Berthing arrangements

Berthing can take place:

Parallel to the quay (Figure 12.6)

This is advantageous for unloading, since fish can move directly from the vessel into the terminal: Consequently, high unloading speeds can be attained, but the required quay length is large. Along such a *marginal pier*, services like fuel, water and ice, are usually only provided over part of its length. However, for bigger fishing vessels which generally make only a brief stop for unloading, refuelling and crew change, services should be available over the full length of quay.

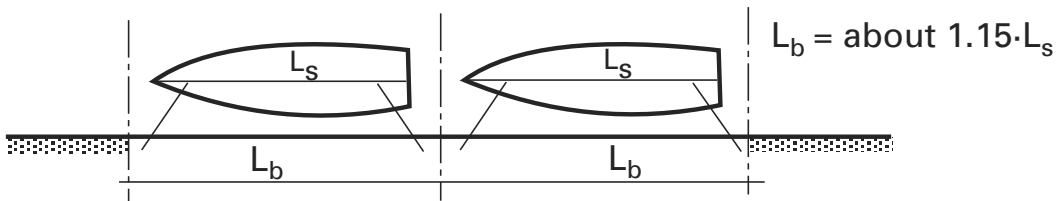

Figure 12.6 Quay length with parallel berthing

Oblique berthing (Figure 12.7)

This reduces required quay length and can be advantageous, provided that there is only little variation in the size of the vessels, in case of a *saw tooth quay shape*. In case of a straight quay, vessel size variation is not so important a factor.

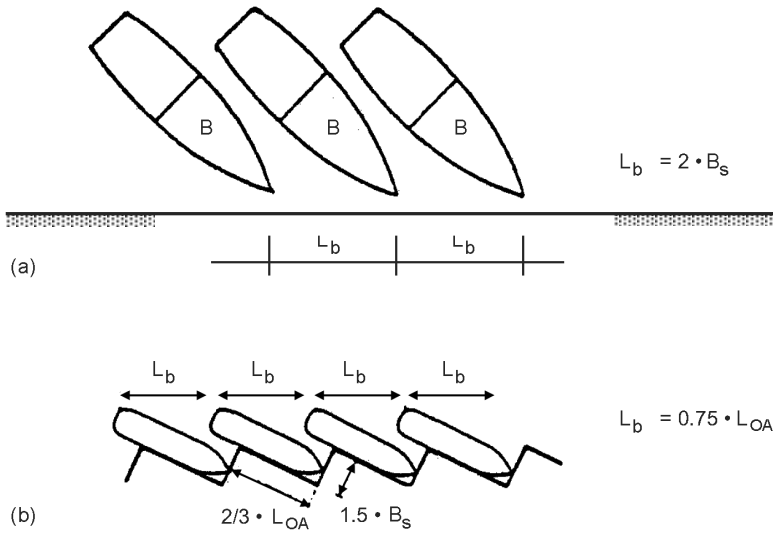

Figure 12.7 Quay length with oblique (a) and saw tooth (b) berthing

Perpendicular to the quay (Figure 12.8)

Berthing can take place either head-on or stern-on. Required quaylength is considerably reduced. This type of berthing, however, virtually limits the unloading possibilities to manual operations.

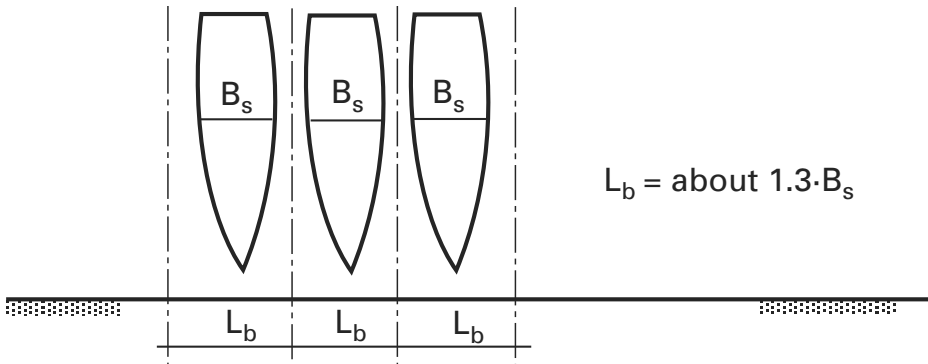

Figure 12.8 Quay length with perpendicular berthing

Fingerpiers perpendicular to the quay (Figure 12.9)

This is a variation of perpendicular berthing, but one that requires transport equipment from the unloading point to the storage zone in order not to limit the unloading capacity too heavily. An advantage of the fingerpier is that both sides can be utilised for berthing. It thus minimises the required quaylength.

Resting quay or jetty length, as an alternative to mooring for unloading, can be estimated with the following formula:

$$L_q = \frac{N_{sr} \cdot (L_s + s)}{N_{sa}} \quad (12.2)$$

in which:

L_q	= required berthing quaylength for resting of vessels	[m]
N_{sa}	= number of vessels abreast (2 - 3)	[-]
N_{sr}	= number of vessels at rest = $\frac{N_s \cdot (n_{dr} + n_{du})}{n_{dc} \cdot f_r}$	[-]
N_s	= total number of vessels	[-]
n_{dr}	= resting days in a cycle	[-]
n_{du}	= unloading days in a cycle	[-]
n_{dc}	= number of days comprising a fishing cycle	[-]
f_r	= irregularity factor	[-]
s	= space between vessels	[m]

In case of the resting quay, flexibility can be found in berthing vessels more than 2 or 3 abreast. In special situations, it is possible to berth up to 8 abreast, which gives a considerable increase in capacity (Figure 12.10).

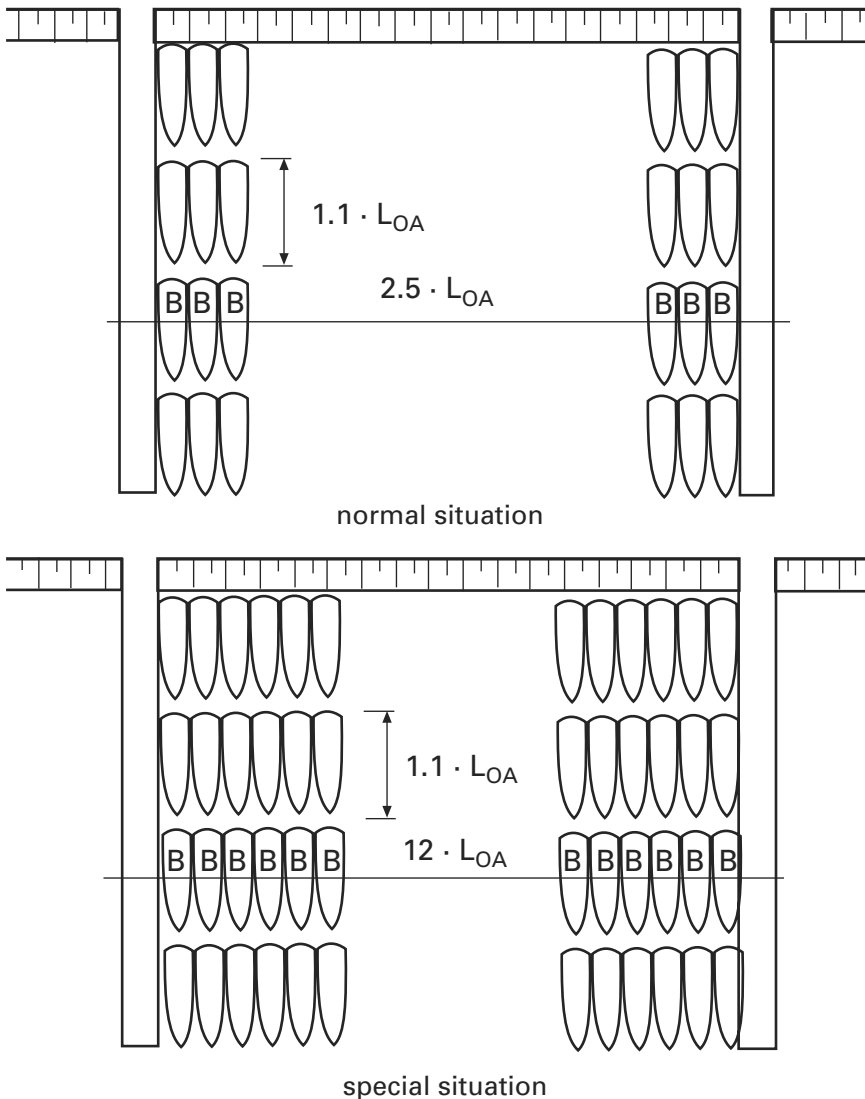

Figure 12.10 Beam-on at finger piers

Quay apron width

Considerations for determining the width of the unloading quay, are the following:

- Exposure of the fish to rain or sunshine should be as short as possible.
- If operations are mechanized, the passage of, e.g., service trucks should not be hampered too much.
- When mobile transport equipment such as forklift trucks or lorries are used, adequate space should be available for turning and passing.
- When transport is mainly perpendicular to the quay, the required width can be less than when there is also parallel transport.

A number of these considerations are, however, contradictory among themselves. For each case, an appropriate compromise should be sought.

As a first approximation, the following values can be given for the width of a marginal quay apron:

- For manual operations, with or without help of ships gear: 1.5 m to 4 m
- For operations with shore-based cranes and conveyors or roller tracks: 4 m to 8 m
- For operations with forklift trucks and/or lorries: 8 m to 20 m

The width of fingerpiers can vary up to 15 m. Sometimes, the reception shed is located on the fingerpier if the available land area is very restricted.

Quay level

Quay platform level is determined by adding tide, waveheight and construction height above waterlevel. For big tidal differences say, 5 m to 6 m or more, dock harbours may be made to facilitate unloading and to avoid high and expensive quays. However, the construction and operation of the necessary ship lock will generally only be economically justified for relatively large fishing centres (see Figure 12.11).

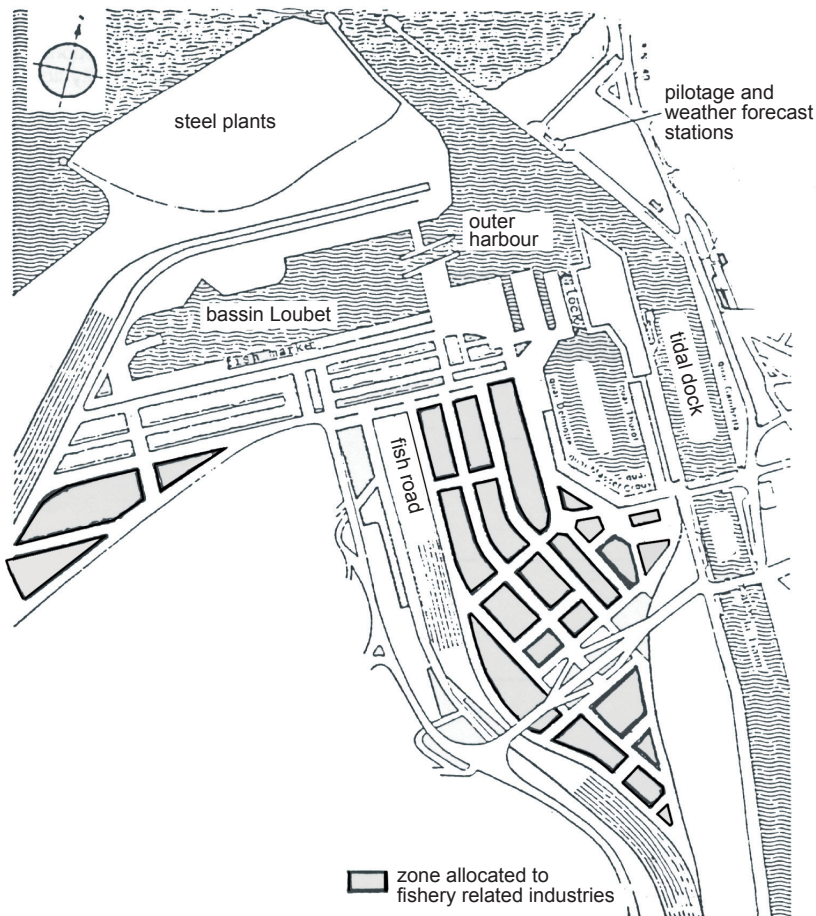

Figure 12.11 Boulogne-sur-Mer: Fishing port and areas reserved for the fishing industry

Ship-maintenance and repair

For vessel repair and maintenance, a conventional *slipway* or simple *lifting device* is usually sufficient (Figure 12.12). Where larger vessels are involved, synchrolifts may be required. Vessels up to 250 tonne can be handled by mobile straddle carrier-type ship lifts. The capacity of repair and maintenance facilities can be determined on the basis of 5 to 15 days per ship per year, depending on the efficiency of the facility and the skill of its labour force.

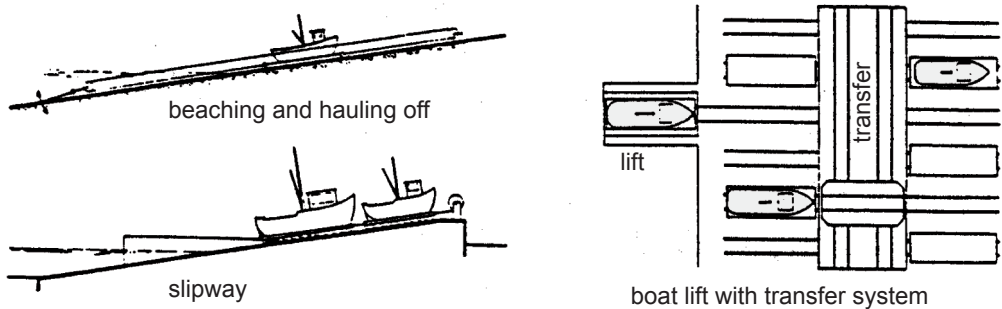

Figure 12.12 Dry-docking arrangements

In tidal ports with sufficient tidal range, repair and maintenance work is sometimes carried out during low tide, whilst the vessels rest on keelblocks in front of the quay.

In addition to the hauling/lifting facilities, workshops will be required (mechanical, wood-working, electrical, electronics, etc.) as well as storage sheds to hold repair materials, e.g. timber and steel elements. A problem, especially in developing countries, is the difficulty of obtaining spareparts due to the lack of standardization in the fishing fleet, absence of a local service agency, restrictive foreign exchange policies and import limitations.

Fish flow

Fish flow through the port, as from the ships hold, can comprise all or some of the following activities (Figure 12.13 and 12.14): unloading, washing, sorting, boxing, weighing, icing, marketing, distribution, storage. It requires a good organization and a terminal layout enabling a smooth commodity flow.

Buildings and other facilities

Market hall or shed (Figure 12.15)

After unloading the catch from the vessels, fish for direct human consumption is usually brought into a market hall or shed, where it is sold to merchants who take care of the onward transport and distribution of the fish. The various activities that may all or partly take place in the market hall or shed, are the following: cleaning, sorting, grading, weighing, re-icing, boxing, display, auction, packing, discharge. Facilities may further have to be provided for boxes and equipment storage, internal transport, temporary cold storage, auction room, offices, amenities, merchant stalls.

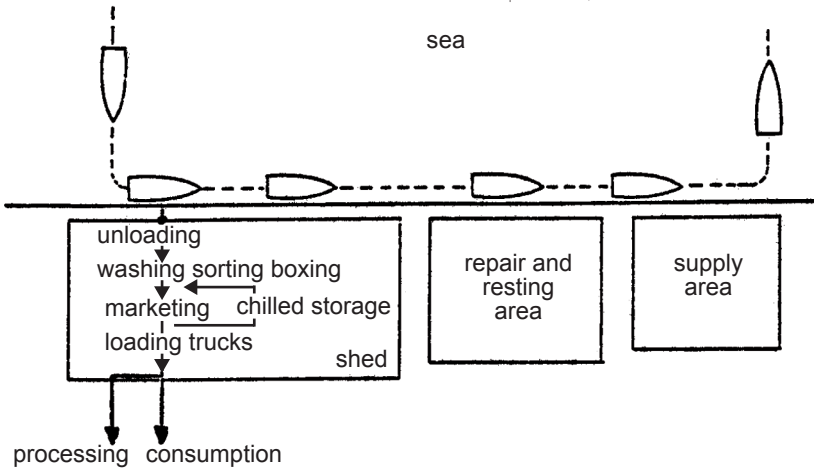
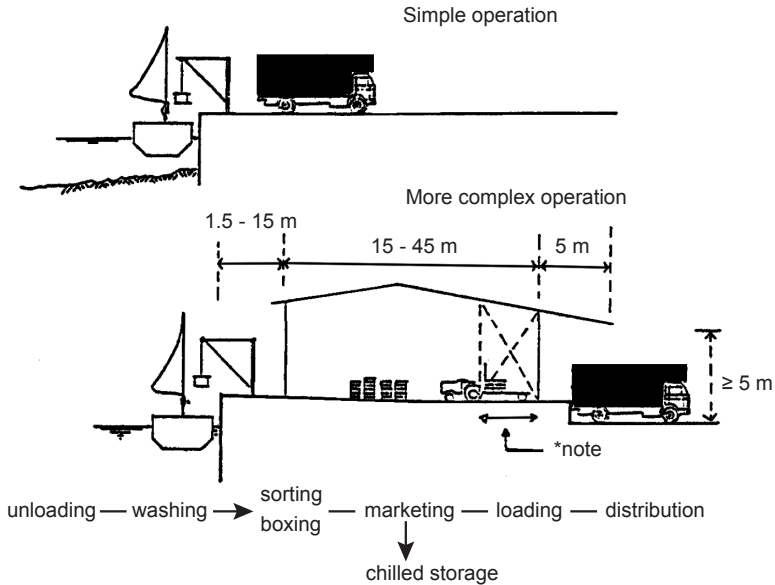

Figure 12.13 Vessel cycle and fish flow



*note: washing, sorting and boxing of fresh fish is sometimes performed in this zone to permit direct transport to inland consumers

Figure 12.14 Fish handling procedure

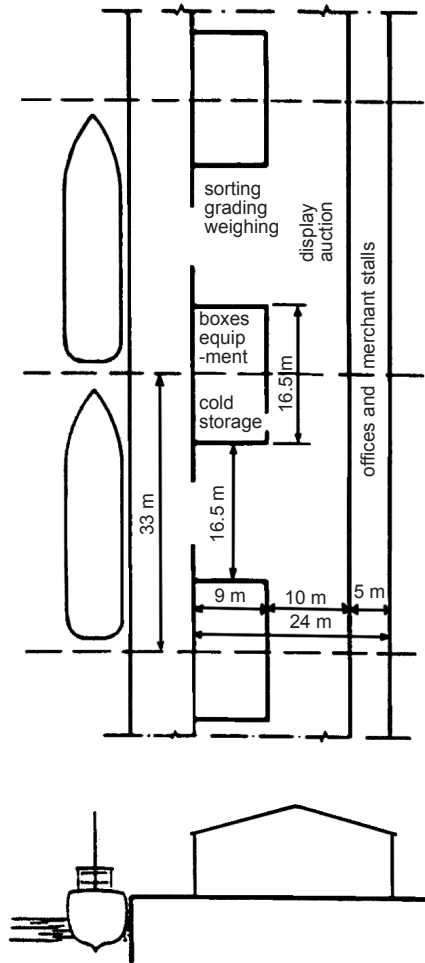

Figure 12.15 Possible lay-out of market hall

The lay-out arrangement and the total space requirements for market halls depend very much on the types and quantities of the catch, the extent of preparation before sales, the system of display, the auction system and the number of auctions, the destination of the catch and the distribution system. Depending on the above factors, the total space requirements may range from $6 \text{ m}^2/\text{t}$ to as high as $25 \text{ m}^2/\text{t}$ per auction. As first approximations, the following figures can be given:

- Preparation of the catch before sales: $4 \text{ m}^2/\text{t}$ per auction
- Display and auction, varying types and qualities: $12 \text{ m}^2/\text{t}$ per auction
- Display and auction, uniform products: $6 \text{ m}^2/\text{t}$ per auction
- Storage of boxes and equipment and temporary storage of products: $4 \text{ m}^2/\text{t}$ per auction
- Offices and merchant stalls: $4 \text{ m}^2/\text{t}$ per auction

For access to the hall, lifting doors extending along both sides of the hall between structural columns, are the most flexible solution. The floor of the shed should not consist of ordinary concrete, but must, in one way or another, be provided with an anti-skid surface. In the shed, electric power and lighting and running water must be available. The water supply is often separated in a fresh- and a sea-water supply. The latter should be a high-pressure system (4 to 5 bar) for cleaning purposes. The installation of the electric wiring, receptacles and switches requires special care, because of the very wet and corrosive environment. The electric lighting should not change the natural colour of the fish.

Ice factory In the initial port planning stages, it may not be required straightaway to plan an ice factory in detail, but it is strongly recommended to allocate a certain area of land for the establishment of such an *ice factory* in future. Ice is not only required for the preparation of fish on board the vessels, but it is also required for preparation of the fish for public auction and for onward transport.

There are two main types of ice factories:

- Block-ice factories (blocks from 10 kg to 150 kg)
- Small-ice factories

A characteristic difference in the lay-out of these types of factories is that block-ice factories have a horizontal transportation system, while small-ice factories usually work vertically, with the ice falling from the ice producing machine into the storage silo underneath.

Space requirements for block-ice production range from 10 m² to 20 m² per tonne of ice per day capacity. Block-ice stowage factor is 1.4 m³/t. Block-ice storage requires some 1.5 m²/t.

Space requirements for small-ice production range from 1 m² to 6 m² per tonne of ice per day capacity. For some types, a building height of up to 10 m may be required. Small-ice stowage factor is 1.6 m³/t to 2.1 m³/t. Small-ice storage requires some 0.5 m²/t to 1 m²/t.

Cold storage Fresh fish is mostly stored, while being iced, in a so-called chill room which is cooled to a few degrees centigrade below zero. Frozen fish is stored in a frozen storage room with a temperature of -20° C. Space requirements can be estimated to range from some 0.5 m²/t to 1.5 m²/t, including access space and the relation gross building area over nett cold storage areas.

Offices, canteens, rest rooms Space requirements depend entirely on the type of fishing port, the number of people involved in fishing operations, port management and administration.

Other facilities These include:

- Net drying and repair
- Fire-fighting
- Supply stores

- Fuel storage
- Gear sheds (maintenance and repair)
- Waste and waste water treatment
- Drainage
- Roads and parking lots

Example lay-out Figure 12.16, in addition to Figure 12.10, gives an example of the lay-out of a fishing port, namely the port of Kalajoki in Finland.

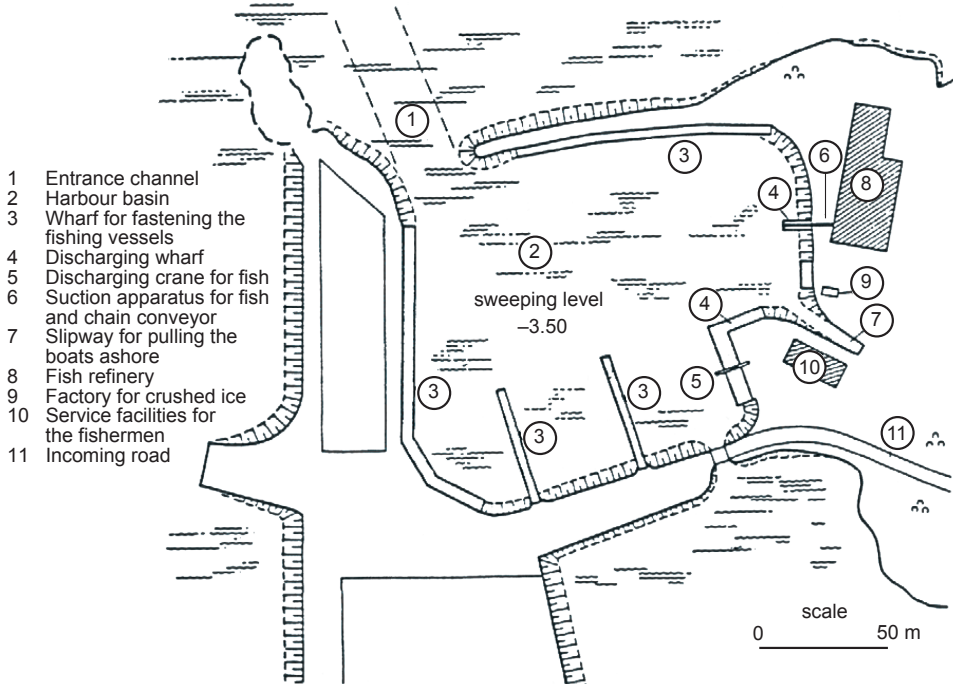

Figure 12.16 Lay-out of the fishing port of Kalajoki, Finland

12.6 Unloading Equipment

Sometimes, vessels use on-board equipment, but more often quay-side cranes, derricks, etc., are used for unloading. The unloading technique further depends on whether the fish arrives un-boxed or boxed. A number of unloading devices are available, such as pneumatic systems, vertical and horizontal conveyor belts, bucket elevators, pumps, etc. (see Figures 12.17 and 12.18). In each case, it should be very carefully considered what the most cost-effective equipment is.

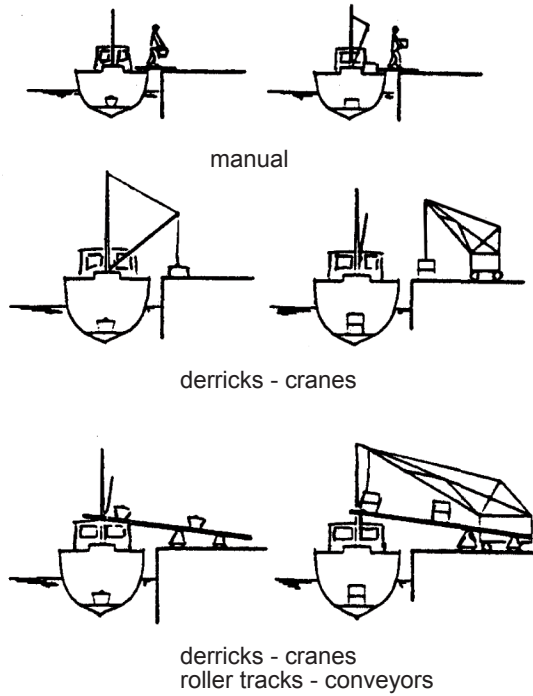

Figure 12.17 Unloading operations

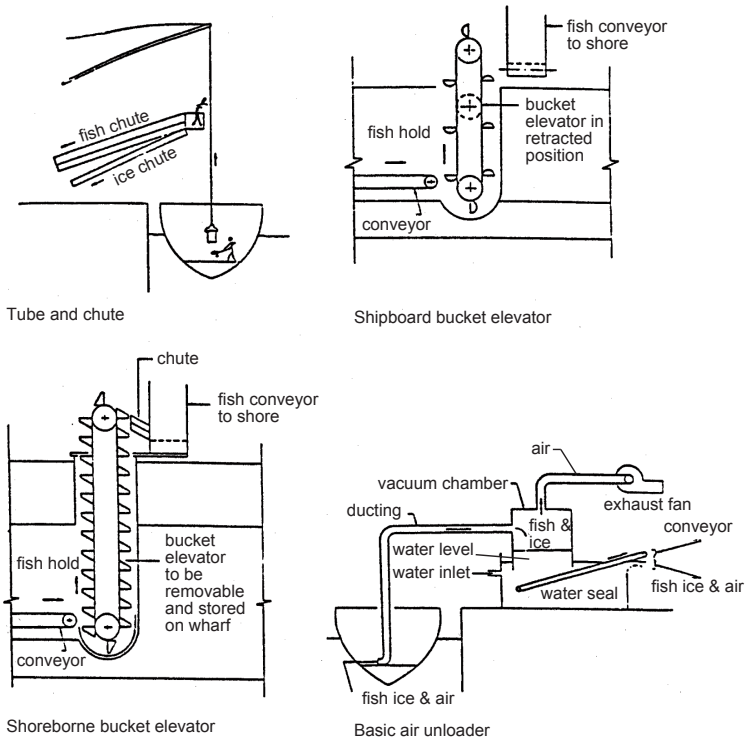

Figure 12.18 Unloading equipment

12.7 Fishery Port Organisation and Management

Quite extensive information on this subject, including legal and institutional aspects of fisheries industry, are present in the PIANC Report *Planning of Fishing Ports* (1998).

Various organisational systems exist:

- Privately owned
- Autonomous port or port trust
- Municipally owned
- State owned

In all instances, a port manager or port director is in charge of the proper functioning of the port. The port captain or harbour master will control all vessel movements inside the port to ensure a proper utilization of the quays as well as to ensure the nautical safety. The port engineer will deal with maintenance and repair of the structures and facilities, and will propose extensions and improvements and supervise development works. An administrator will keep a record of statistical data on landing operations and catch rates. He will also be in charge of the usual administrative functions.

Other services such as unloading, sales, ice supply, cold storage, water and power supply, waste treatment, security, fire-fighting and the provision of repair facilities may form part of the port organisation's activities and, as such, require separate offices. But, it may also be that a number of these activities are dealt with by fishery organisations or private owners under the general regulations of the port authority.

In case of small ports, the organization can be reduced to a one-man administration force with some clerical and technical assistants.

12.8 References

- FAO, Fishery Harbour Planning, Fisheries Technical Paper no. 123, Rome, 1973
FAO, Fishery Harbour Planning, Construction and Management, Fisheries and Aquaculture Technical Paper no. 539, Rome, 2010
PIANC, Planning of Fishing Ports, Report of WG PT II-18, Brussels, 1998
UNCTAD, Port Development, United Nations, New York, 1985

Chapter 13

Marinas

13.1 Yachting and Yachts

Yachting covers so many different aspects, that a very thorough analysis of the requirements to be met must take place before port development can be initiated. It stands to reason that the facilities to be built and the services to be put into operation are closely dependent on the specifications of the ships to accommodate and on the way they are operated. This varies according to:

- The origin of *yachtsmen* (local people living more or less near the harbour and using their boat during weekends or holidays, tourists staying in a resort in the port vicinity, charters, etc.).
- Their tastes (sailing, ocean cruising, yacht races, fishing, water-skiing).

Thus, the facilities to develop can fit into the pattern of the development plan maritime waterfront oriented at yachting or, conversely, they can be limited to a local yachting club. It cannot be overemphasised that such options should be duly considered, since the blind transfer of lay-outs that were successful elsewhere, may give rise to great disappointment. The structure of the fleet that enables one to determine the lay-out and the size of berthing facilities is a factor of major importance for the preliminary survey. The diagram of Figure 13.1 shows that, from port to port, the assumptions that have to be taken into account for the drawing up of plans vary quite a lot. The disparities would certainly be bigger if one was considering the actual frequency of ships' visits at these very ports. The *port lay-out* is directly connected with the characteristics and operating conditions of boats, viz.:

- The general design of the entrance fairway and its dimensions may depend, to a large extent, on yachts that call at the port, which sail to the wind at less than 45° (at least, small-sized boats having no auxiliary engine).
- Small craft can and often have to be put ashore, their launching taking place on ramps. Weather conditions can even entail a quasi-permanent lay-up of big craft under shelter, in which case a small crane is needed.
- Craft making cruises require, during their stops, accommodation facilities related to life afloat.
- Incorporation of maintenance and repair operations in the marina, requires the development of special facilities (yards, dry-docking facilities)

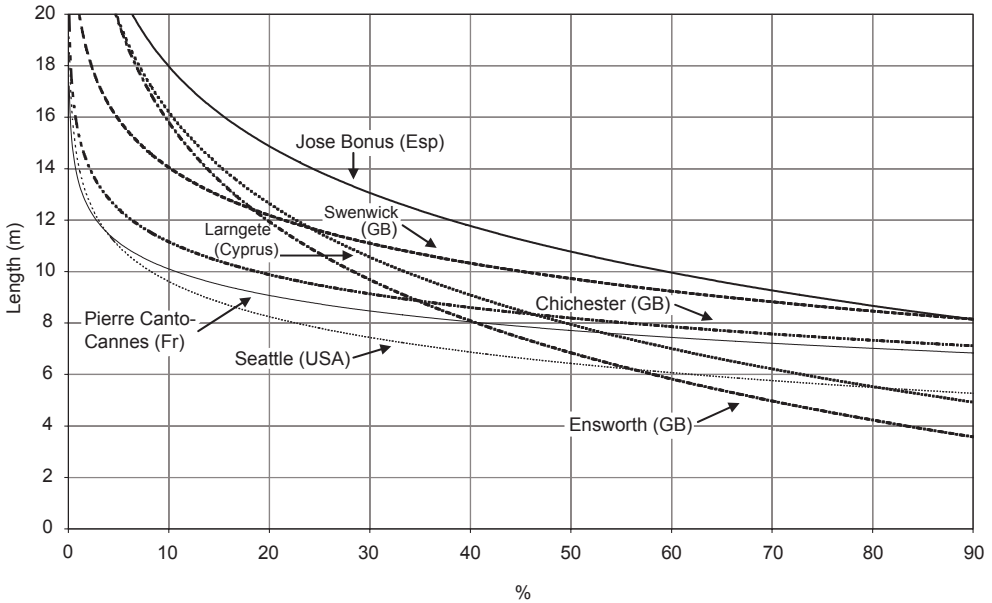

Figure 13.1 Percentage of ships exceeding the given lengths

Fig. 13.2 and 13.3 give the relation of beam to length for motorboats and sailing boats respectively. Fig. 13.4 and 13.5 give similar relations for draught to length. These figures have been taken from PIANC, 2016a.

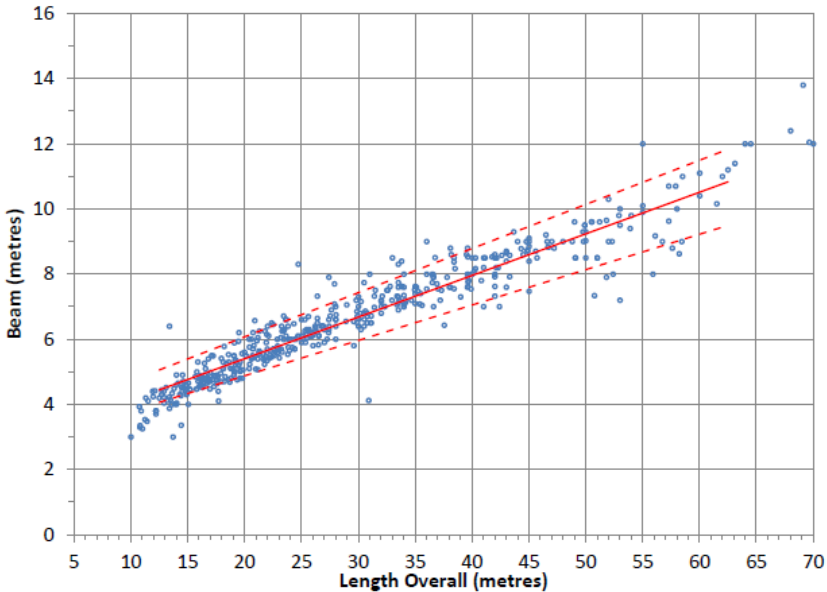

Fig. 13.2 Beam to Length relation (motorboats)

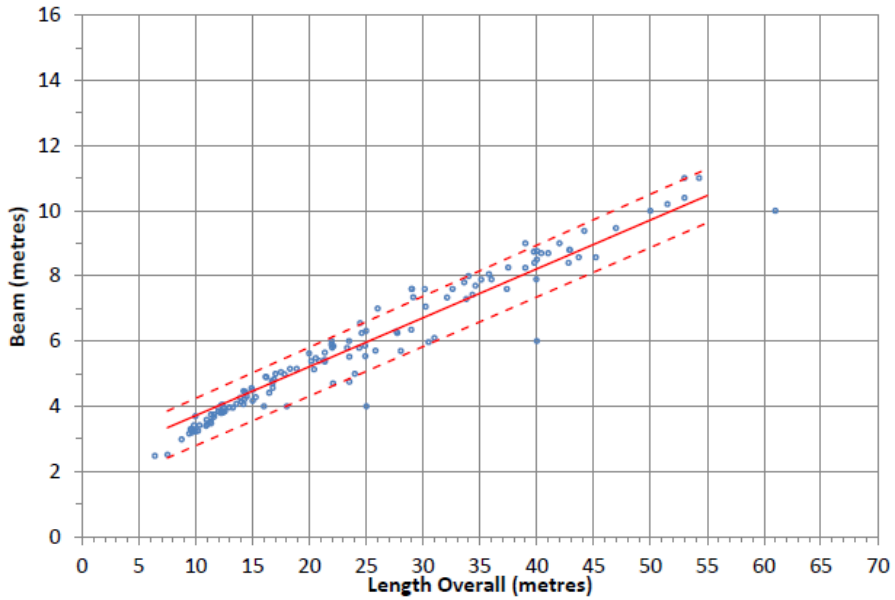

Figure 4-2: Beam to Length Overall Relationship (sailing boats)

Figure 13.3 Beam to Length relation (sailing boats)

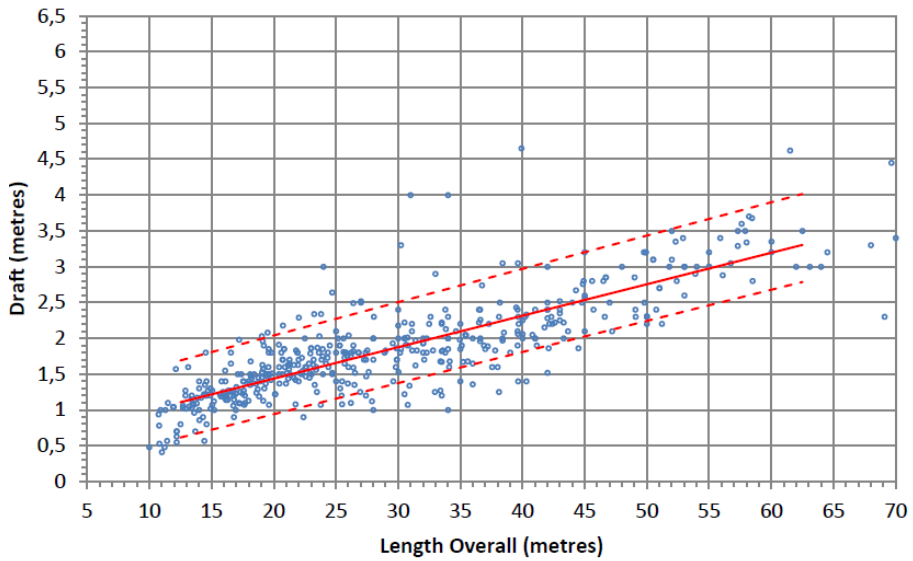

Fig. 13.4 Draught to Length relation (motor boats)

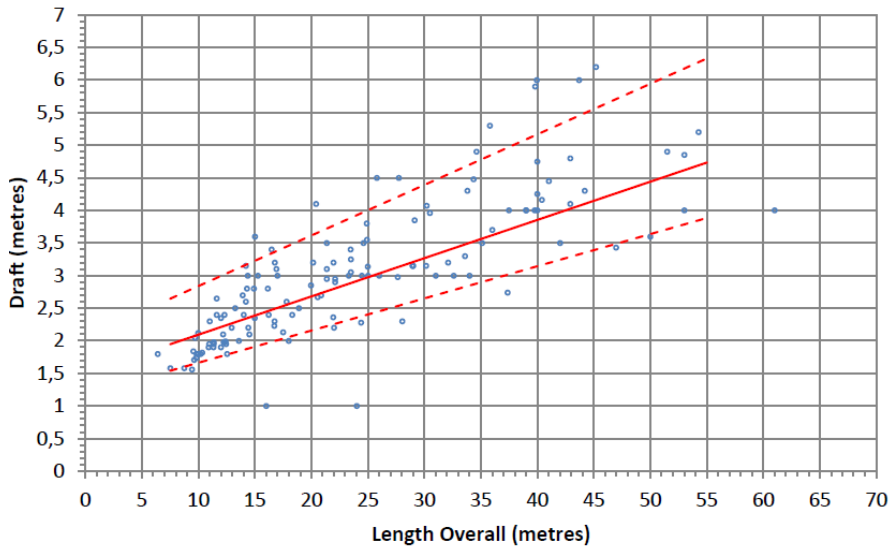

Fig. 13.5 Draught to Length relation (sailing boats)

13.2 General Lay-out of the Port

What a yachtsman expects from a marina, is a series of services given in a pleasant environment:

- Adequate shelter from high seas
- Docking services: periodical maintenance of his boat at reasonable prices and without undue waiting
- Mooring and watching of ships
- Seasonal storage ashore of small ships in open yards or in sheds
- Parking for yachtsmen's cars
- Quick execution of incidental repairs
- Marketing of new and used boats
- Administrative or private services (harbour master's office, weather forecasts, customs, clubs, medical needs, etc.)

The choice of a site for a marina, if not dictated by recreational facilities which have to be integrated in the new project, should result from maritime and nautical considerations, with a view to simplifying the nature of the works to be carried out, and to lowering the cost. It should also depend on environmental considerations in accordance with rules, standards and regulations that locally apply. Lastly, the integration of the port into all other developments in progress or being planned ashore, has to be ensured.

For master planning purposes, the most important factor usually concerns wave conditions. Along open coasts, marinas must generally be protected by solid breakwaters. In more protected areas, other systems can be considered, e.g. floating breakwaters.

Ports often comprise an outer harbour in which waves are still somewhat rough, and an inner harbour - better sheltered - in which the actual berths are located. When the tidal range is small, the inner harbour can be designed to provide a sufficient depth of water to keep boats afloat at all times. When the tidal range is big, it is often accepted that the berths fall dry at LW. If not, a relatively expensive shipping lock has to be provided.

Access conditions to the harbour have to be carefully considered. The lay-out, of course, will have to ensure an adequate protection of the *entrance* against wave action and against siltation. Furthermore, the lay-out should be such that *small boats* without an engine can enter or leave the port, which implies that channels shall be wide enough to tack, whenever needed. A 2-way channel designed in accordance with the rules presented in Ch. 5.3.4 generally satisfies this requirement. Further, ship movements must be able to continue without undue problems, even during rush hours. Especially in view of the dense traffic in most ports the engine is required for those vessels that have one. The above implies that the entrance channel must be properly oriented, providing quartering wind and wave conditions for the dominant directions, and should have a width of 30 m or more (for 2-way channels).

For the required draught of the channel the design approach for seagoing vessels can be applied (see Ch. 5.3.3).

Bends in the approach channel near the entrance should be avoided. Inside the entrance a bend can be necessary in order to reduce wave agitation in the inner basin. For such bends a minimum radius of $1.3 L_s$ is acceptable, but a larger radius is recommended if space is available. PIANC, 2016b).

13.3 Basins and Berths

In port zoning or basin designation, distinction is usually made between:

- Basins in ports of call that do not require large back-up areas (no car park), and around which the harbour master's office, administrative offices (customs, border police, weather forecasts, etc.) and different service facilities (lavatories, showers, information, post office) are set up.
- Basins assigned to yachts registered at the port, surrounded with big car parks.
- Basins for maintenance which, in addition to floating repair berths, comprise lifting equipment and a general technical area, including yards for boats to be dry-docked, workshops and laying-up sheds.

The size of the basins, or zones, will have to be determined according to the particular requirements of the port. As a first estimate, their total area A can be taken as equal to 80 the total capacity of the port, in terms of number of yachts N_s that can be accommodated:

$$A = 80 \cdot N_s$$

Mooring facilities are oriented in such a way, that ships will be moored facing the prevailing wind direction. The scheme adopted for the position of the different berths, and, especially, the clearance between the piers and berths, depends on several factors that have to be carefully weighed in every case. Any port characterised by high tidal range and, consequently, by strong tidal currents, or by frequent and strong winds, will require larger manoeuvring areas in-between piers (and shorter piers) than a sheltered port at which the tidal range is small.

Some arrangements involving *floating pier systems* are shown in Figure 13.6. The parallel berthing arrangement is common for *visiting piers*. It can also be used in initial phasing for small marina developments. Several types of perpendicular berthing arrangements exist. The two most common appear to be the *bow-out mooring system*, where the craft is boarded across its stern directly from the floating pier, and the popular *slip/finger arrangement*, where the boat can either berth the bow or the stern towards the main walkway and is boarded from the side finger. The former is less costly, while the latter is more convenient for mooring and ship access and hence safer.

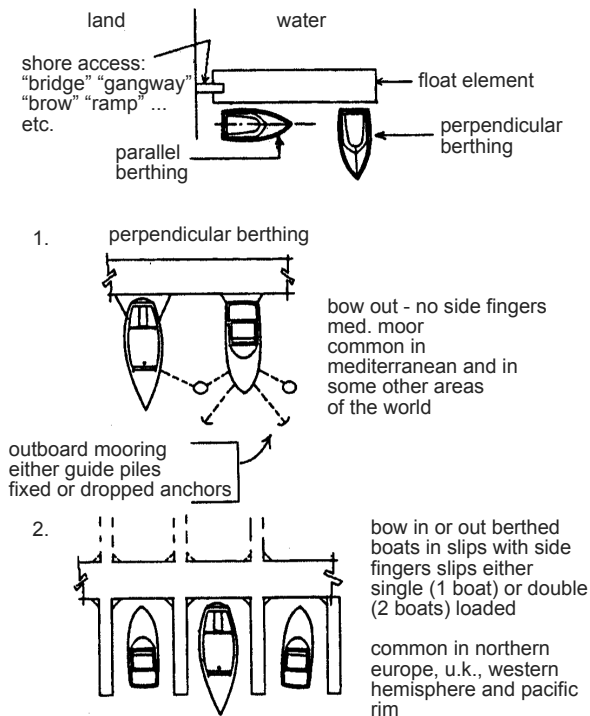

Figure 13.6 General arrangement involving floating docks

In dimensioning the basin, including fairways and berth areas national standards have been published in several countries, e.g. Australian Standards (2001), British Guidelines (2013) or US Guidelines (ASCE, 2014). A comprehensive overview of these standards and guidelines is given in PIANC (2016c). The main dimensions concern the marina's wet areas, i.e. the length and width of a slip and the width of the fairway, all in relation to length and beam of the boats L_s and B_s :

- (i) The length of the slip, L_b , in most standards equals the largest length of boat that can by regulation be berthed in the slip. In some guidelines the length of the finger, L_f , may be chosen shorter than L_s by up to $1/3 \cdot L_s$.
- (ii) The *slip width* is determined by adding a double clearance to B_b in case of a single slip and a triple clearance for a double slip. This clearance varies from 0.3 - 0.5 m, whilst for boat lengths above 15 m values of 1.0 m are found.
- (iii) The fairway, in this case the water area between the slips, has a minimum width of $1.5 \cdot L_s$ with $1.75 \cdot L_s$ preferred.

These guidelines are summarised in Figure 13.7. The width of walkways and finger piers are standardised by the manufacturers of these systems and depend on the length of the walkway and B_s respectively.

- (iv) For lengths of walkways up to 200 m a width of 1.8 m is standard.
- (v) The finger piers have a minimum width of 0.6 m, increasing to 1.5 m for $L_s > 15$ m

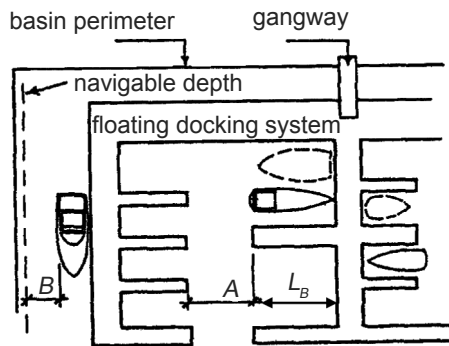

- A = fairway width - perpendicular slips = $1.5 - 1.75 L_s$
- B = fairway width - side parallel berth
- L_s = length of berthed boat
- L_b = length of slip = $L_{s, \max}$

Figure 13.7 Guidelines for marina's wet areas

Figure 13.8 shows an example of the lay-out of a large marina.

The size of car parks to be developed, depends mainly on the kind of utilisation of the boats accommodated in the harbour. The number of vehicles to park can range from a few units to twice (or even 2.5 times) the number of boats laying in the harbour. Taking into account the high cost and all environmental inconveniences of car parks at the seaside, the trend is towards minimising facilities in the port and transfer of the parking lots to inland locations. Boats carried on road trailers have to be provided with ordinary launching equipment (usually a ramp, at least when the tidal range is not too big) and close to a vast parking lot for boats and, if need be, for cars. This applies, in any case, to ships laid-up ashore.

Figure 13.9. In case of a rectangular pontoon the transmission coefficient C_T becomes a function of both depth of submergence and width of the pontoon, as shown in Figure 13.10 for a ratio of wave length over water depth $L/h = 1.25$. For more details on wave transmission reference is made to Ofuya (1968). An overview of design and construction aspects of floating breakwaters is given in PIANC (1994).

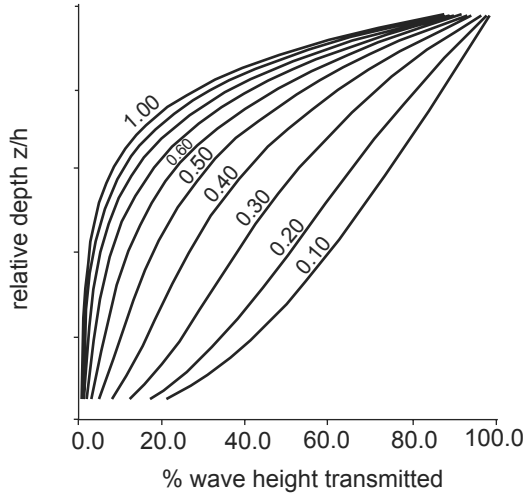

Figure 13.9 Wave height transmission as function of water and structure depth

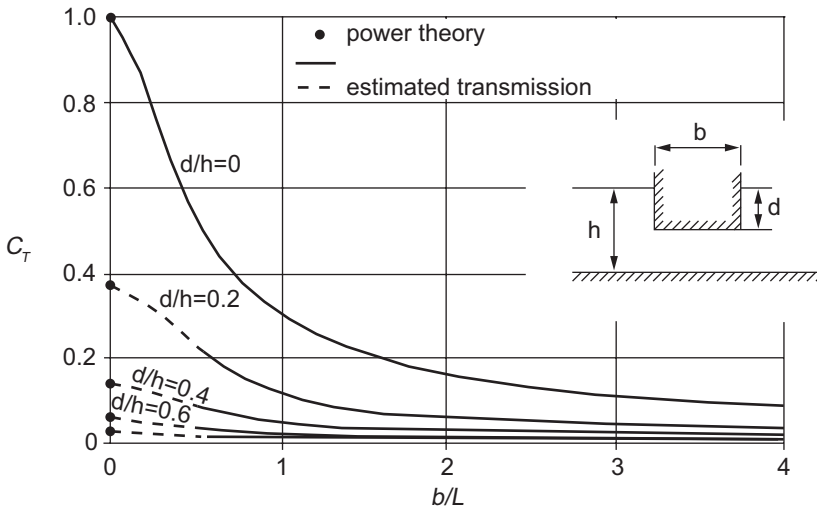

Figure 13.10 Transmission coefficient for rigid, rectangular surface barrier ($L/h = 1.25$)

Quays and *fixed jetties* are only found in marinas where the tidal range is low (less than 1.50 m), for the level of the boat deck must stay close to that of the berthing facility to facilitate embarkation and disembarkation.

13.5 References

- Australian Standards, Guidelines for design of marinas,, AS 3962, 2001
- British Guidelines, A Code of Practice for the design and construction of marinas and yacht harbours. The Yacht Harbour Association, 2013
- Ofuya, A.O., On floating breakwaters, Queens University C.E. Research Report No. 60, 1968
- PIANC, Floating breakwaters, a practical guide for design and construction, Report WG PTC II-13, Brussels, 1994
- PIANC, Review of selected standards for floating dock designs, Special Report SPN Commission, Brussels, 1997
- PIANCa, Guideline for marina design, Report no. 149, Part I, Brussels, 2016
- PIANCb, Guideline for marina design, Report no. 149, Part II, Brussels, 2016
- PIANCc, Guideline for marina design, Report no. 149, Part III, to be published
- US Guidelines, Planning and design guidelines for small craft harbours, ASCE Manuals and reports on engineering practice, no. 50, New York, 2014

Chapter 14

Ports and Terminals for Inland Water Transport

14.1 Location and Lay-out of IWT Ports

An inland water transport port can vary in scope from a sophisticated multiple basin complex with up-to-date handling equipment, to a one-berth terminal on the bank of a river or canal where, now and then, some goods and/or passengers are (un)loaded. But, a commercial IWT port always is an inter-modal node of land-based and water-borne transport.

In addition to the commercial ports, one can distinguish along rivers and canals:

- Harbours of refuge, providing shelter to ships during floods or ice drift
- Night stop ports, where ships without night navigation aids may lay overnight
- Service harbours for contractors equipment, survey launches, etc.

Among the commercial ports one can distinguish:

- The general-purpose port which is a multi-user interface between IWT and other modes of transport (road, rail) and which, generally, offers storage facilities.
- The dedicated container or other port terminal, sometimes multi-user, sometimes single-user.
- The industrial port which is, in general, the end of the line of IWT, and directly unloads raw materials and loads (half-)finished products.

With the rapid growth of barge transport in Western Europe, especially for containers, also new terminals are developed along the main rivers and canals.

14.2 The Vessels

14.2.1 General

The type and size of vessels used for inland navigation varies widely from one region or river basin to another, and is often the result of historic developments and of specific local conditions as available water depth, current velocities, type and volume of the commodities to be carried and degree of techno-economic development. On rivers, coastal canals and 'backwaters' in India, one can still observe a multitude of small wooden ships with sail-assisted human propulsion (the so-called country craft), next to motorised barges.

At the other end of the line are the huge push-barge convoys, carrying up to 50,000 tonnes, travelling up and down the Mississippi River in the USA, and the sea-going vessels plying up the Amazon as far as Iquitos in Peru.

14.2.2 The European Waterways

In Europe, self-propelled vessels and barges for push-tows have been standardised and divided in classes which correspond with waterways with a given minimum water depth and width. The CEMT classification has been lastly modified in 1992; the new version is given in Table 14.1.

Nowadays, the self-propelled vessels form the majority of the craft plying the European waterways. Occasionally, they can be seen pushing or side-towing a dumb barge to increase their carrying capacity.

At present, a number of cargo vessels are being converted, and new ships are being built, to carry containers which, at long last, have found their way in numbers to waterborne transport. This is not surprising as, except for the short distances, IWT is quite competitive. A special feature, although not new, is the retractable wheelhouse needed for good visibility over the stack of containers in front.

New designs of barges for container transport are found at both sides of the range. Where the large Rhine vessel (Class Va) can carry only about 120 TEU, a specially designed container barge with a length of 134 m and a beam of 16.8 m has a capacity of 500 TEU. Several of these ships are presently in service (see Figure 14.1).

And for small canals a modern version of the Kempenaar (Class II), the Neo-Kemp has been developed, with dimensions $L_s = 63$ m, $B_s = 7$ m and $D = 2.8$ m, carrying maximum 32 TEU (see Figure 14.2). A special design feature is the wheelhouse being placed at the bow, in order to limit its height to the upper level of the containers. Another important innovation is the anti-heeling system, that keeps the barge horizontal, even when there is unbalance in the number and/or load of containers on both sides of the longitudinal axis. This avoids the reduction of (un)loading rate, caused by heel.



Figure 14.1 Container ship 'Jowi' has a capacity of 398 TEU

Table 14.1 Classification of waterways by CEMT

Type of inland waterways	Classes of navigable waterways	Motor vessels and barges						Pushed convoys				Minimum height under bridges (m)
		Type of vessel: general characteristics						Type of convoy: general characteristics				
		Designation	Length (m)	Beam (m)	Draught (m)	Tonnage (T)	Tonnage (T)	Length (m)	Beam (m)	Draught (m)	Tonnage (T)	
Of regional importance	I To West of Elbe	Barge	38.50	5.05	1.80-2.20	250-400						4.00
		Campine-Barge	50-55	6.60	2.50	400-650						4.00-5.00
		D.E.K.	67-80	8.20	2.50	650-1000						4.00-5.00
Of regional importance	II To East of Elbe	Grosse Finow	41	4.70	1.40	180						3.00
		Barka	57	7.50-9.00	1.60	500-630						3.00
		Motorowa 500										
Of international importance	III		67-70	8.20-9.00	1.60-2.00	470-700						4.00
	IV	R.H.K.	80-85	9.5	2.50	1000-1500	85	9.5	2.50-2.80	1250-1450		5.25 or 7.00
	Va	Large Rhine Vessels	95-110	11.40	2.50-2.80	1500-3000	95-110	11.40	2.50-4.50	1600-3000		5.25
	Vb						172-185	11.40	2.50-4.50	3200-6000		7.00 or 9.10
	Vla						95-110	22.80	2.50-4.50	3200-6000		7.00 or 9.10
	Vlb		140	15.00	3.90		185-195	22.80	2.50-4.50	6400-12000		7.00 or 9.10
Vlc		6 barges, long 6 barges, wide				270-280 193-200	22.80 33.00-34.20	2.50-4.50 2.50-4.50	9600-18000 9600-18000		9.10	
VII						285 195	33.00 34.20	2.50-4.50 2.50-4.50	14500-27000 14500-27000		9.10	

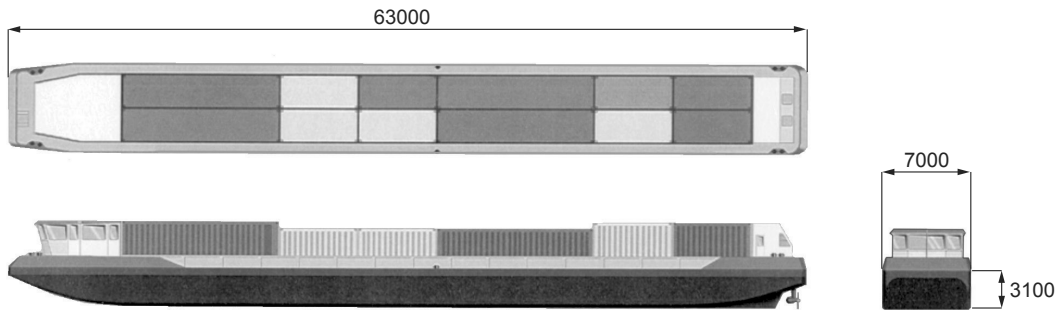

Figure 14.2 RPC standard 32 TEU containership

There is a big fleet of tankers ranging in size from 300 tonnes till over 3,000 tonnes, plying all the navigable waterways. Since the first inland tanker was constructed in 1903, their technical outfit has been gradually improved and adapted to the various POL-1 products, of which the safety requirements form an important aspect. The majority of the tanker fleet consists of self-propelled vessels. Other more specialised tankers carry chemical products and liquid gases, and are equipped with extensive and expensive safety devices. But, skill and knowledge of crew and operators form the basic ingredients for a safe transportation and handling of dangerous products.

Traditionally, the coasters used to penetrate deep inland with their overseas cargo. However, their manoeuvring characteristics are not exactly what is required for navigation in confined and shallow waters. Often, a dangerous situation or accident occurred when coasters merged into the inland traffic. Nowadays, the 'Rhine coaster', a new type of sea-river vessel, has become popular for this purpose of linking inland ports with overseas destinations without transshipment. Based on the lines of modern inland vessels and adapted to sea-going requirements, they operate successfully and safely.

Push-barges have grown in size from 1,200 tonnes at 3.00 m draught to 2,700 tonnes at 4.50 m draught by increasing length as well as beam. Consequently, the tow sizes grew from 5,000 tons in a four-barge convoy to over 10,000 tonnes. Nowadays, the maximum size convoy on the Rhine consists of 6 barges, carrying 15,000 tonnes and needing all of the 6,000 HP installed in fourth-generation pushers. These 6-barge push-tows were formally accepted after a long period of tests and trials in the seventies and early eighties.

In 25 years, the installed push-boat power has dramatically risen from the initial 1,200 HP on 2 screws to 6,000 HP on 3 propellers. However, the rising fuel prices have somewhat dampened the ideas of this unrestricted expansion. Often, it can be observed that big pushers sail at lower than normal cruising speed with throttled power.

In the present conditions, the 4,500 HP pusher may turn out to be the optimum size, considering also the economic speed in restricted water. A draught of 2.4 m (pusher) is more or less the maximum for year-round commercial navigation in the Rhine catchments area. Self-propelled cargo vessels have grown substantially as well, carrying up to 4,000 tonnes.

Whereas the principally private owners of these vessels did not dare to think of ships bigger than 1,300 tonnes some time ago, they now have also fallen for the economy of scale. Still, quite a number of the 300 tonnes 'Peniche' class vessels are in operation, and all sizes in between.

Passenger vessels have shown a remarkable development as well, but on the Rhine these vessels are commercially operated in the summer season only.

All of the IWT fleet makes use of the available waterway infrastructure of which, on average, the cost per shipload is quite low compared to other modes of transport.

14.3 Types of Ports

14.3.1 Open River Ports

Open ports on rivers with a confined flood plain may be located either in that flood plain, i.e. in between the river and the HW dike, or beyond the flood plain outside the dike.

If inside the HW dike (Figure 14.3)

- To keep quays dry, the area must be reclaimed above HW. This may obstruct the river discharge during floods.
- The entrance channel will also disturb HW current patterns, and ships will be impaired by cross-currents when entering or leaving the port basin.

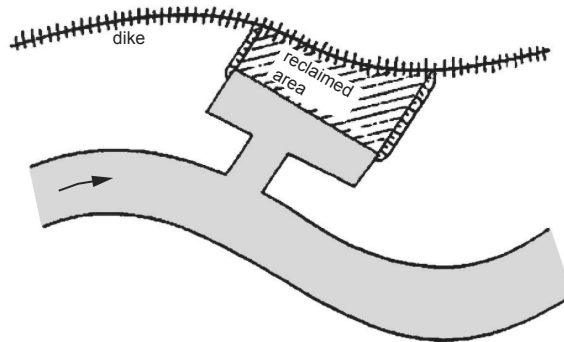

Figure 14.3 River ports and reclamation inside dike; flooded during HW; possible flow constriction

If outside the HW dike (Figure 14.4) the entrance channel cuts through the dike, so the port must be enclosed by new dikes and/or quays with a deck level equal to the crest level of the dikes.

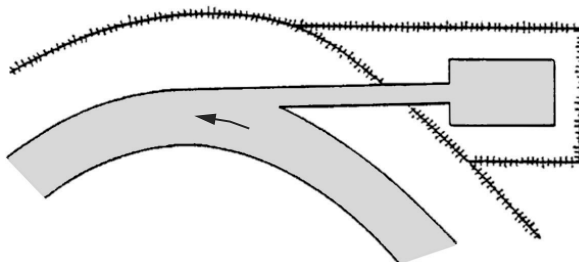

Figure 14.4 River ports outside original dike with open connection

Main advantages and disadvantages of open ports are:

Advantages	Disadvantages
<ul style="list-style-type: none"> • always accessible • full-width entrance channel available 	<ul style="list-style-type: none"> • variable water level • wave disturbance from the river • expensive berths due to water level difference • low cargo handling efficiency due to relatively much vertical transport • siltation • expansion often difficult

14.3.2 Closed River Ports

Closed river ports are provided either with a retaining lock or a ship lock.

River port with lock gate (Figure 14.5)

The lock gate serves as an HW defence, and can be closed when the river exceeds a certain level. This closure blocks all traffic (but at such high water there will be no traffic to/from the port).

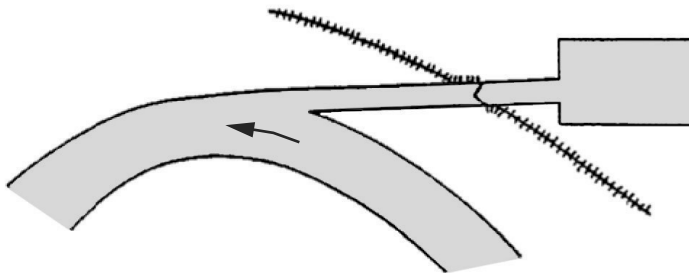

Figure 14.5 River ports outside dike with lock gate

Main advantages and disadvantages are:

Advantages	Disadvantages
<ul style="list-style-type: none"> • less expensive berths than for open port • easy expansion 	<ul style="list-style-type: none"> • periodically, vessels are locked in (including those with dangerous goods!) • gate width limits ship size • upgrading means new lock gate • pumping required when gate is in use (seepage and leaks) • when open, same as for open port • construction, operation and maintenance costs of lock gate

14 Ports and Terminals for Inland Water Transport

An example is the port of Cuyk on the river Meuse (Figure 14.6). The lock gate is closed during a few days per year only. It limits ship widths to 14 m.

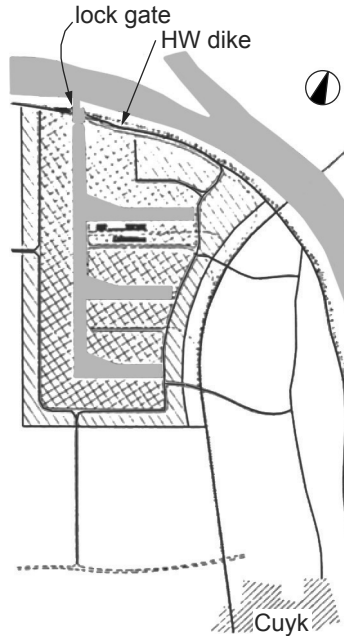

Figure 14.6 Port of Cuyk

River port with ship lock (Figure 14.7)

Main advantages and disadvantages are:

Advantages

- constant water level
- sheltered mooring (against waves from other vessels)
- minimum vertical transport of cargo
- relatively cheap berths

Disadvantages

- loss of time due to locking
 - lock width limits ship size
 - pumping needed
 - in case of calamities, difficult evacuation
 - construction, operation and maintenance costs of lock
 - waiting berths needed for lock
-

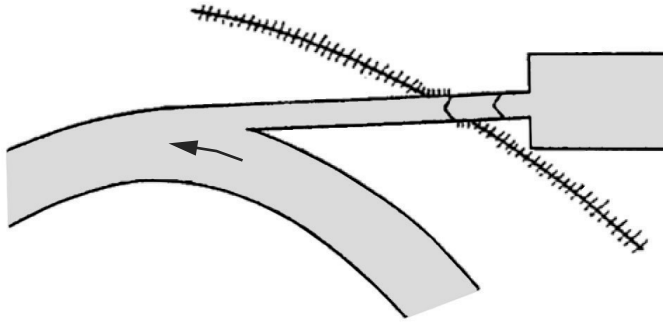

Figure 14.7 River ports outside dike with ship lock

An example is the port of Oss on the river Meuse (Figure 14.8).

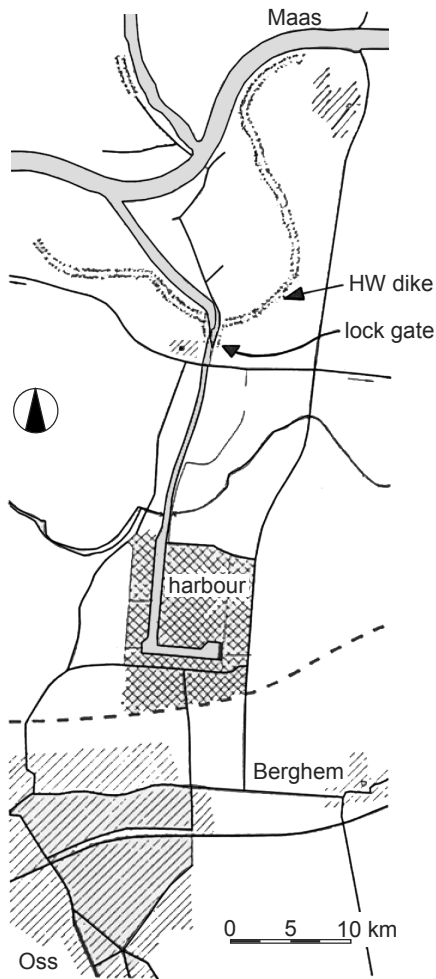

Figure 14.8 Port of Oss

14.3.3 Canal and River Ports: Lay-out and Dimensions

For the lay-out of IWT ports and the dimensions of entrance and basins general guidelines have been developed by the Dutch Commissie Vaarweg Beheerders (CVB, Commission Inland Waterway Authorities) in its report of 2006. The following guidelines are taken from this report:

- (i) (Un)loading quays along the channel shall be avoided, in case of waterways with more than 15,000 barges per year and in any case along waterways Class V and higher. Where allowed, it is desirable to have the ship at berth entirely outside the theoretical channel boundary. The quay wall will be placed at a minimum distance from the channel boundary of B_s , the beam of the design ship. When more than one berth is needed, these should preferably be separated in order to keep sight of the original channel boundary (see Figure 14.9).

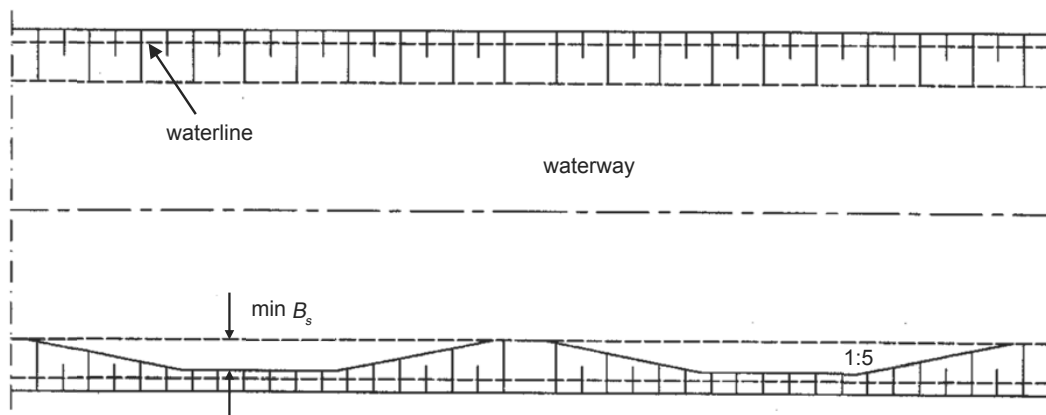

Figure 14.9 Berths along the waterway

The length of the quay wall amounts to $1.1 L_s$, L_s being the length of the design ship. The earth retaining structures on both sides shall have an angle less than 1:2 with the channel boundary in order to facilitate arrival and departure manoeuvres.

- (ii) Harbour basins along the waterway will be located in or connected by means of side channels. At the connection there has to be sufficient line of sight (see Figure 14.10). The width of a harbour basin has to be minimum $4B_s$, if there are berths on both sides.

Along rivers the harbour entrance should preferably be oriented in an upstream direction, i.e. in such a way that the vessels can enter against the current (manoeuvring is easier and safer in this way). Wherever possible the entrance will be located on an outer curve of the river to benefit from available natural water depth and to minimise siltation in the entrance (see Figure 14.11).

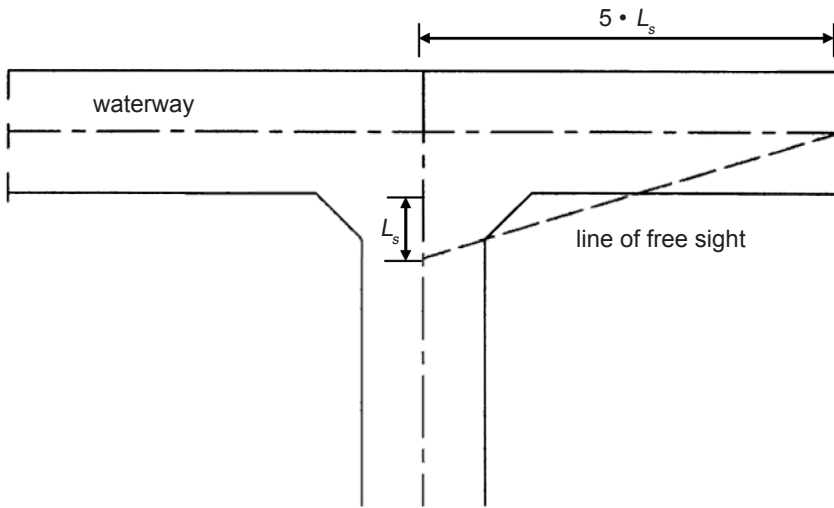

Figure 14.10 Line of free sight at side channels

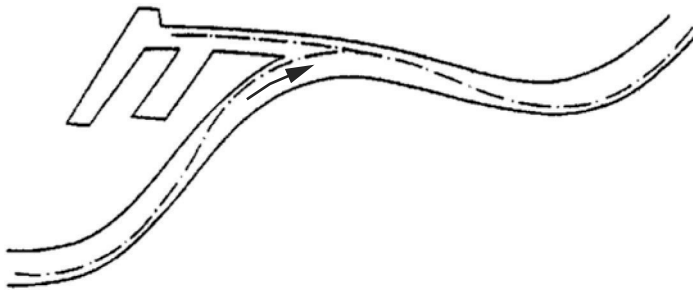

Figure 14.11 Entrance to a harbour along the river

The harbour entrance has to be sufficiently wide for ships to pass each other. A minimum value is 60 m for ships up to class Va. If push-tows frequently visit the harbour basin the minimum value is 80 m. Alternatively a mooring berth is provided near the entrance, where the push-boat and the different barges can be disconnected. The barges are subsequently towed to their berths by a small tug. For a 4-barge push-tow the mooring berth needs a space of 225 x 25 m outside the waterway boundary.

(iii) Turning circles are needed in the vicinity of (un)loading quays and at the end of harbour basins with a length of more than $5 L_s$. The diameter of the turning circle amounts to $1.3 L_s$. If located adjacent to the waterway, the turning circle shall fall within the axis of the waterway (see Figure 14.12). Again for push tows the length of the individual barges shall be applied.

A last comment is related to dangerous cargo. Ships with dangerous cargo require special treatment. Since the inland water transport of mineral oil products and liquefied gases increases rapidly, this issue constitutes a point of special concern for many IWT ports. Whe-

never possible, these vessels should be in fully current-free water in basins, exclusively reserved for these cargoes and which can be easily sealed off by floating booms in case of spills or other accidents.

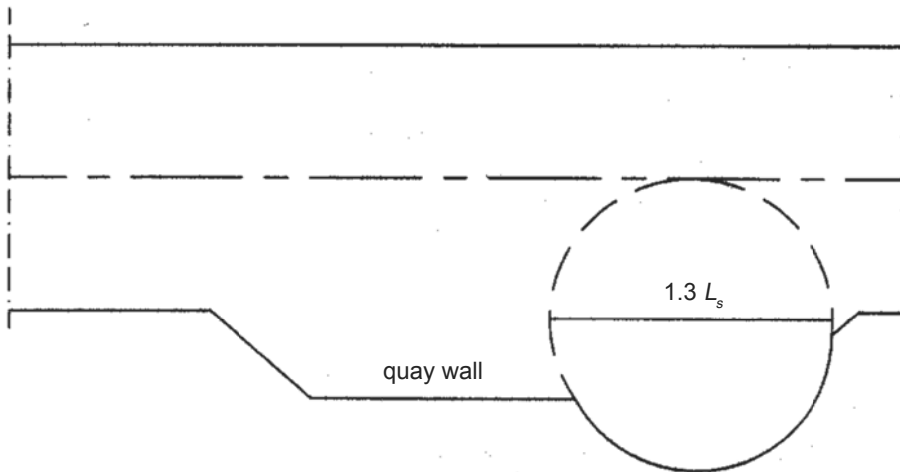

Figure 14.12 Turning circle at unloading quay

14.4 Terminals

14.4.1 IWT Cargo Terminals

When cargo is moved over the waterway from an inland terminal to a seaport terminal, and vice versa, or between IWT terminals, suitable provisions should be present for cargo handling, for storage and for interchange with other modes of transport. The main component at an inland terminal's infrastructure will be a quay or jetty, where vessels can safely moor at any water level, and where loading and unloading can be performed efficiently. Quays will often be used for terminals in closed river ports.

Jetties for terminals in open river ports can be either fixed or floating. A choice between the two is dependent on the method of cargo transfer that will be applied (manual or mechanised), but also on the water level variations to be expected as well as the configuration of bank or embankment at the selected site for a terminal (see also Section 14.4.4). A fixed jetty has the advantage that it can be constructed rigidly and stable, even allowing heavy equipment and trucks to drive on it. A serious handicap is that, even with limited water level variations, the jetty platform rises high above the vessel's deck during the low water stage. This can be met by the construction of a number of jetties for various levels, but the costs involved could easily turn the balance in favour of floating jetties. Another disadvantage of fixed jetties is that they can seldom be moved to other and more suitable locations, when a changing configuration of the river bank or a changing transport pattern would require so. A floating jetty has the flexibility to be moved at any time, but the weak side is often the construction of a land-connecting footbridge or ramp. This is particularly so when this bridge has to span a considerable length of shallow water or mud along the bank. A

floating jetty must also be secured against lateral movements, either by anchors, moorings or guide poles. Especially during high floods, the force of the current against the pontoon and a pack of vessels moored alongside, may be considerable.

14.4.2 Cargo Handling

In developing countries, the (un)loading of barges is sometimes still done manually. However, in most cases some form of mechanisation, or partial mechanisation, has been introduced on terminals in the developing world.

From an engineering point of view, mechanisation of cargo handling has a considerable impact on the design of an inland terminal and, especially, on the design of a jetty. The jetty is the crucial part of the process of cargo transfer from vessel to land, and vice versa. There, a substantial amount of vertical transport happens, combined with horizontal transport over the jetty to or from truck, wagon or storage shed (Figure 14.13).

When the cargo is handled manually, the jetty platform should preferably be level with the vessel deck, but there remains a notable vertical lift from the vessel's hold onto the deck. Some sort of lifting gear, preferably on the jetty itself, will facilitate this part of handling, and will also eliminate the problem of a jetty towering above the vessel during low water stages. This lifting gear can range from a simple (hand-operated) derrick to an electric hoist, or even a more sophisticated piece of equipment as a mobile crane. With this equipment, further mechanisation is within reach when additional trucks, flatcars or forklift trucks are used for horizontal transport. Still, it will require stable and not too sloping jetty platforms as well as metalled roads or rail tracks for through-transport.

In case of a floating jetty, connected to the bank by a footbridge or ramp, a part of the vertical and horizontal transport can be achieved with conveyor belts, provided that, in general, the slope does not exceed 25° to 30°. The conveyor belt, being a very versatile piece of equipment for cargo handling, can also be used on a fixed jetty with large water level variations. This installation is not only perfectly suited for the transfer of bulk cargo as sand, gravel, rock and coal, but also for bags, small bundles, cartons and small crates. Bulk cargo should preferably be carried on flat-top barges, from where it can be easily shovelled onto the conveyor belt.

Other methods of mechanised cargo handling include the use of overhead ropeway systems, cable-suspended drag buckets, various types of grab or continuous barge unloaders, and the like, which are usually designed for applications in industrial ports or terminals.

IWT container terminals require one or more container cranes with a lifting capacity of about 40 tonnes. Since the beam of IWT vessels or barges is less than that of sea-going container ships, the crane's outreach from the quay edge can be appreciable less than that of cranes of deep-sea terminals. Also, the trolley and hoisting speeds are mostly lower, resulting in lower investment cost. Nevertheless, a capital outlay of some Euro 2 million, or over, is still a big investment in IWT terms.

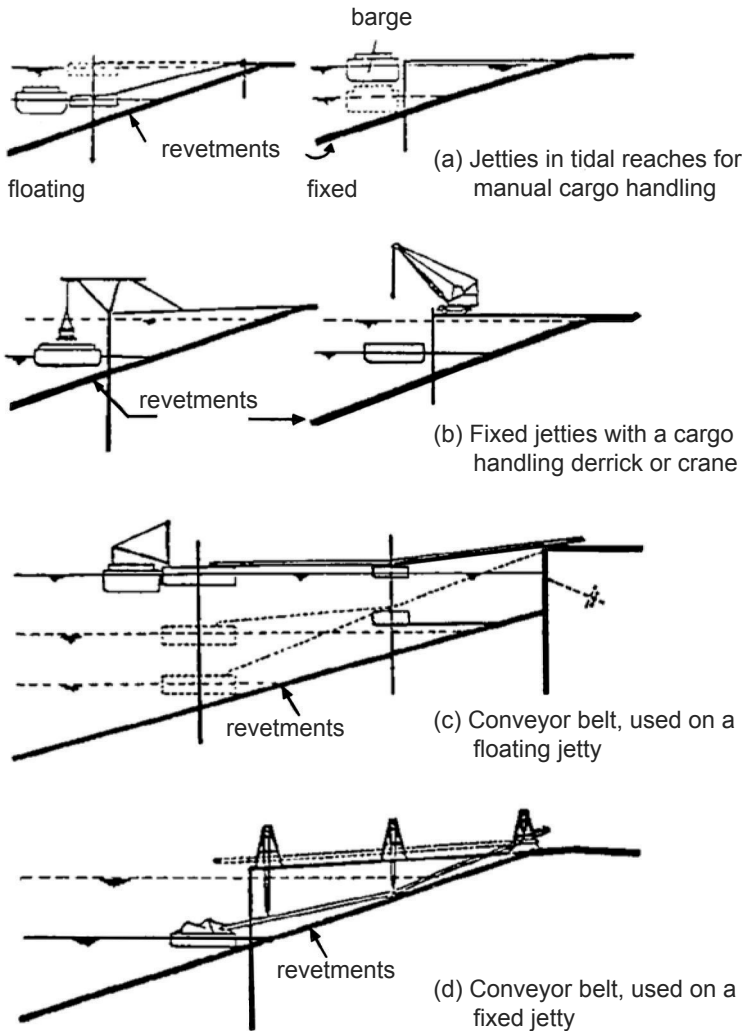

Figure 14.13 Types of jetties

14.4.3 Storage

Storage area at IWT terminals depends on the type of cargo handled. If this is general cargo or (increasingly) containerised cargo the surface area can be determined with the respective equations in Chapter 8 and 7.

14.4.4 IWT Jetties on Rivers with a Large Seasonal Water Level Variation

The considerable investments in the construction of a terminal capable of coping with large water level differences must be justified by the throughput. As long as that throughput is not guaranteed, the investments should be kept to a minimum. Often, a shore connection with planks on floats, e.g. empty drums, will allow loading and unloading with a local

workforce. But, when the cargo flow is growing, a more permanent facility will be needed. Once a feasibility study shows that the investment in a jetty is justified, the design of a jetty adapted to the local conditions can start. Figure 14.14 shows a schematic shore cross-section and the hydrograph.

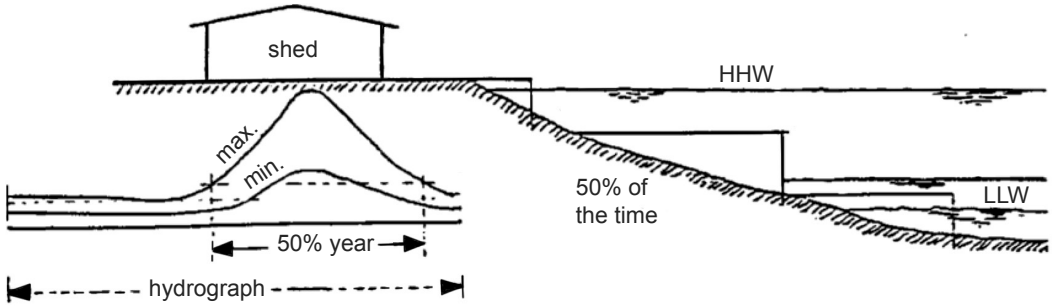

Figure 14.14 IWT stepwise jetty

It appears logical to design one jetty for HHW and one for LLW, and, if desired, one or more in between. But, in practice it is rarely provided so for the following reasons:

- For an appreciable period of time, the water level is in a zone where the lowest jetty is too low and the middle one too high.
- HHW is exceptional and lasts for a short period only (e.g. 1 week every 10 years) and, therefore, does not justify the investment in a jetty. Furthermore, during such exceptional high levels, the current will reduce shipping to a minimum, and road and/or rail connections are probably flooded.
- During the period that a jetty is flooded, but not yet enough to float a barge over it, the terminal is hard if not impossible to use (Figure 14.15). The water levels, projected on the hydrograph, demonstrate that this situation can last for several months per year.

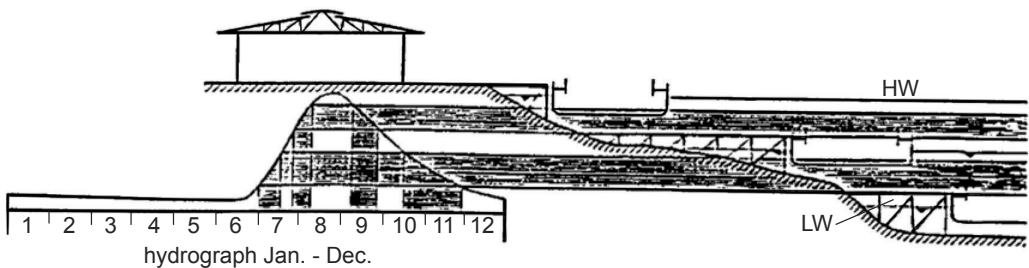

Figure 14.15 Interruption of terminal operations

- Even when the three, or more, jetties are constructed staggered along the shore, the solution is not attractive because the lowest jetty is used more than twice as long as the others combined, and, therefore, should attract more than half of the investment.

In general, a floating jetty is the cheapest solution (Figures 14.16 and 14.17). It allows trucks to come near the barge and, thus, reduce carrying distance for the dock labour. The road should not be constructed too steep (maximum 1:15) to allow a loaded truck to negotiate it without undue effort. Along the road, rails or channel irons should facilitate

movement of the connecting bridge or ramp when it has to be raised or lowered. The ramp must be connected to the pontoon with solid hinges. This allows the use of the anchor and mooring winches of the pontoon to move the ramp. If required, a winch near the top of the slope may be needed to help pull the ramp upward.

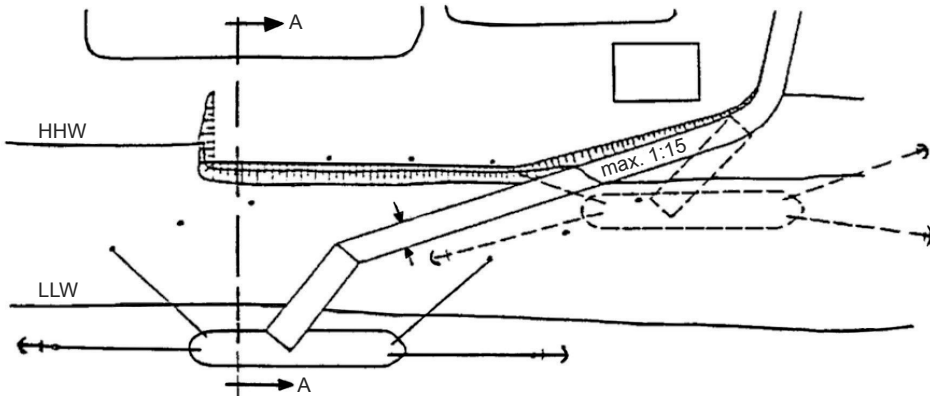

Figure 14.16 Pontoon terminal

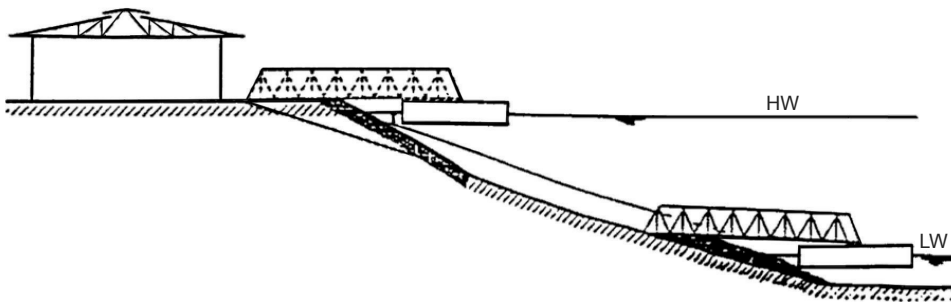

Figure 14.17 River terminal cross-section AA

Bollards or mooring rings should be installed along the slope for fixing strong mooring wires. The anchors should be provided with enough shackles of heavy chain to resist current and mooring forces. An additional advantage of this kind of jetty is the possibility to move the floating part to another site once the terminal becomes obsolete.

Some examples are given in Figures 14.18 and 14.19. Figure 14.18 shows terminal facilities in Bangladesh for relatively low water level fluctuations in the lower reaches of the *Brahmaputra/Ganga river system*. Figure 14.19 shows port facilities at *Iquitos* on the Amazon in Peru, designed for a water level difference of 10.60 m. Certain navigable river stretches in China sustain level fluctuations of as much 30 m for which it becomes quite difficult to design good terminal facilities.

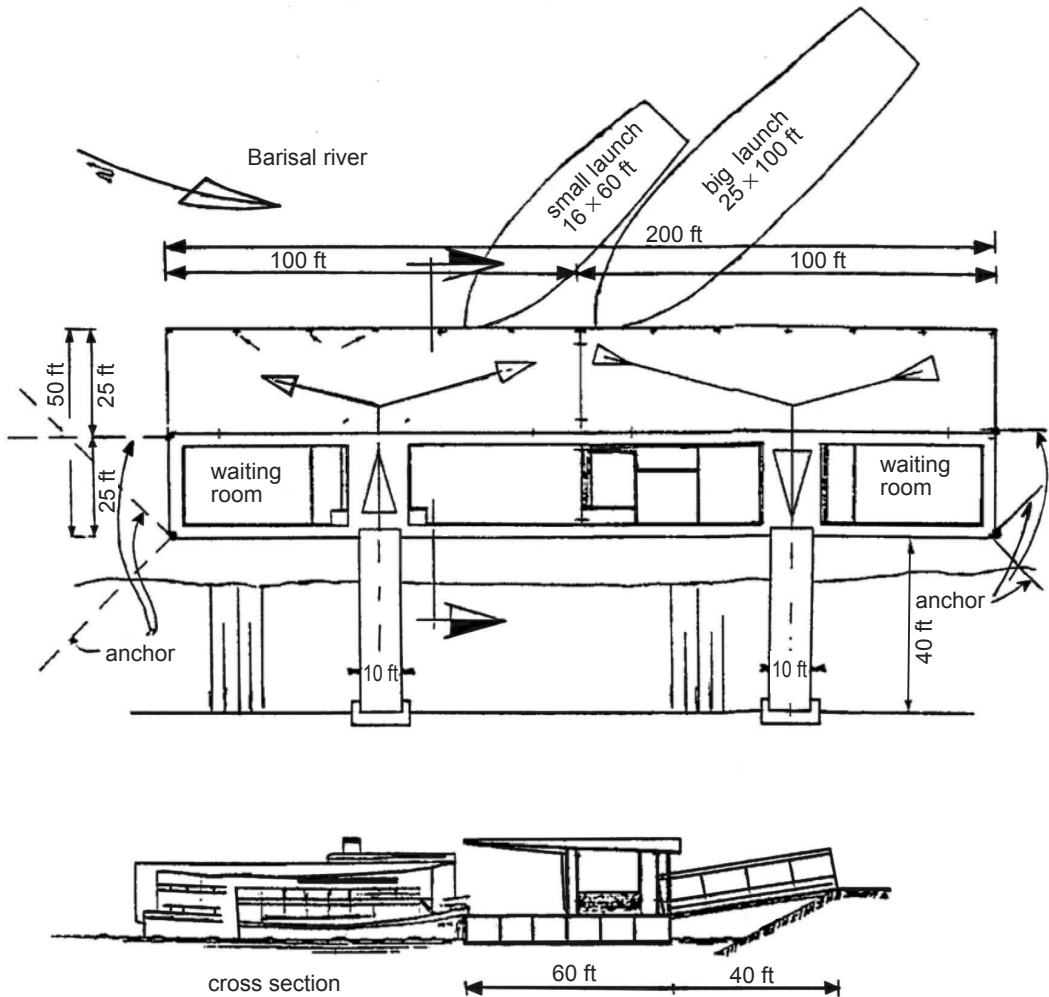

Figure 14.18 Barisal, design of floating launch station with anchors

14.4.5 Design Aspects for a Simple IWT Canal Berth

A berth may be a quay wall, a fixed jetty or a floating jetty. Whatever it is, the structure must be capable to carry the vertical loads of cargo, trucks, people, cranes, etc. (see Figure 14.20). In addition, it must withstand the horizontal loads. The indicated forces may fluctuate considerably, so a thorough analysis is needed. Particular attention should be given to sudden change of the water pressure caused by passing ships.

Ship impacts may be considerable, e.g. in case of a failing manoeuvre (kinetic energy to be absorbed). In this respect, a very subjective criterion plays a role, namely how rough a berthing manoeuvre is still considered 'normal' or 'acceptable'. For quay wall designs, the concentrated design load (acting on 0.5 m^2) is taken as shown in Figure 14.21.

14 Ports and Terminals for Inland Water Transport

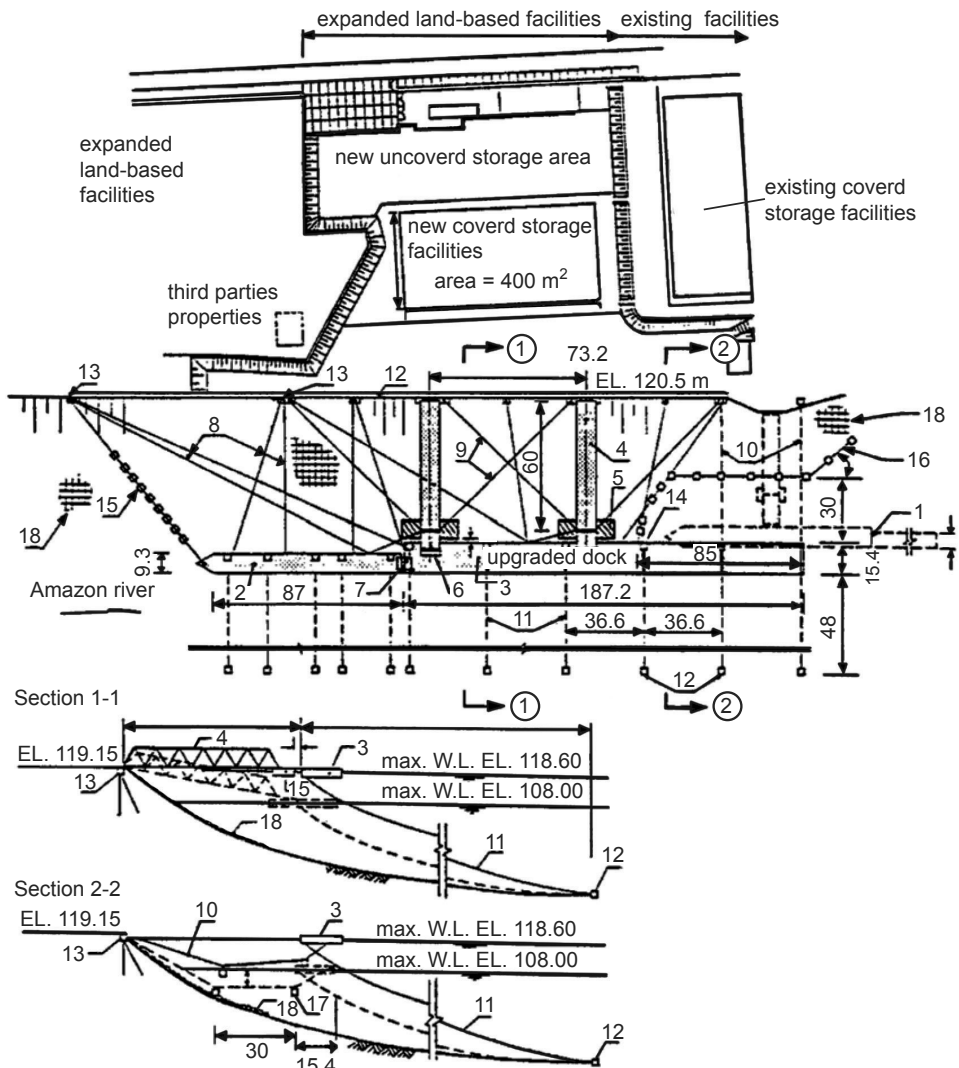

- | | |
|--|-------------------------------------|
| 1 Location of an old dock | 10 Depressed inshore mooring cables |
| 2 Part of an old dock incorporated into the new pier | 11 Offshore mooring cables |
| 3 New pier | 12 Anchors |
| 4 Acces bridge | 13 Land-based piled deadmen |
| 5 Bridge support pontoon | 14 Winch |
| 6 Ramp between bridge and pier | 15 Upstream floating log |
| 7 Ramp between two parts of a new pier | 16 Downstream navigational aids |
| 8 Inshore mooring cables | 17 Concrete block |
| 9 Bridge keeping prestressed cables | 18 Slope protection |

Figure 14.19 Port of Iquitos on the Amazon river, Peru: general lay-out and typical cross-sections

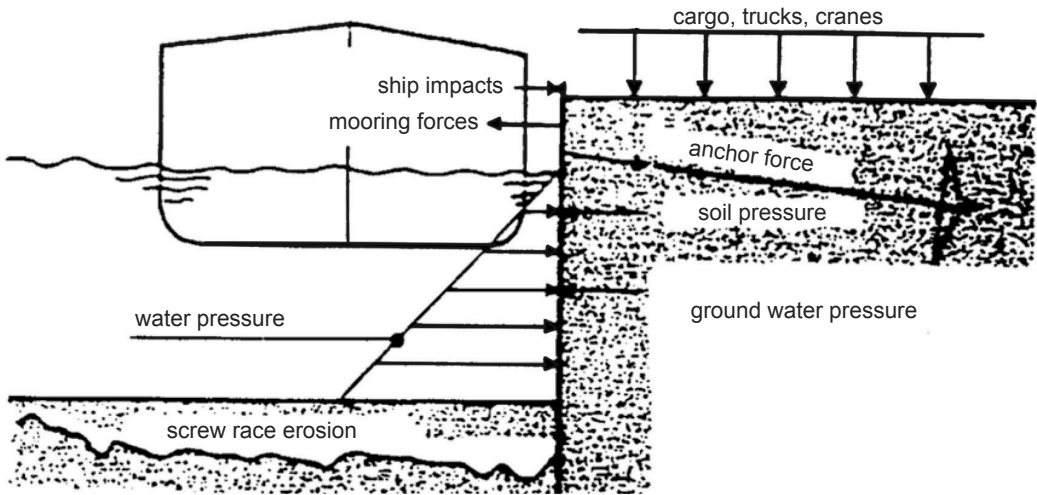

Figure 14.20 Design loads for quay walls

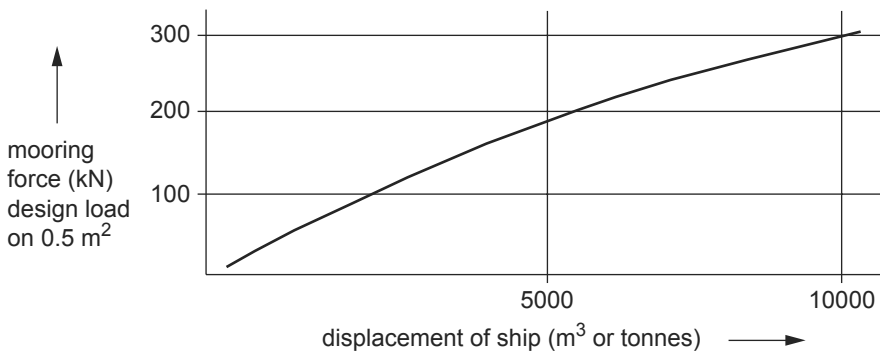

Figure 14.21 Design load on quay walls and bollards

The given values of design loads on quay walls and bollards apply to stiff structures (sheet pile walls). If a good flexible fendering is provided, the impact loads will decrease. One should check if a design load for the quay wall can really be exerted, considering the design ship's own strength.

Bollards should be situated near the quay or jetty edge so that a deckhand can put a mooring line directly over the bollard when the ship approaches the berth. The design load depends on the mooring lines on board of the ships. The rule of thumb for the mooring forces is the same as for the aforementioned collision loads; so, for inland vessels about 10 to 30 tonnes. These forces may act both in a longitudinal and a lateral direction. Spacing between bollards should be about 10 to 30% of the design ship length (Figure 14.22). This will also fit for many smaller vessels. The shape and size of the bollards on the jetty are very important to prevent unnecessary wear and to avoid lines slipping over the bollard's top.

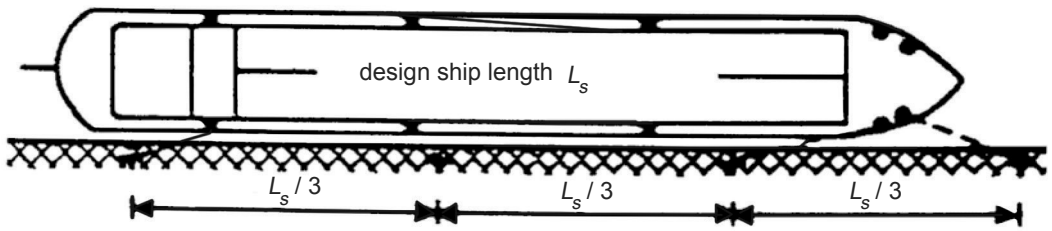

Figure 14.22 Spacing of bollards

Near a berth, ships will often be manoeuvring. Consequently, the risk of concentrated screw-race erosion is relatively high, and should be given due attention. To prevent stability problems, possible sheet piling should be given some overdepth.

The external forces acting on a jetty (Figure 14.23) are much alike the forces on a quay wall. Special stiffening will be needed to withstand the longitudinal forces exerted by a moored ship, which is affected by passing ships and/or regular flow in the canal. Attention should also be given to the risk of screw-race erosion, because it is very likely to attack the bank slope. Damages of that slope may not be noticed in time, and a serious bank slide might be the result. Repair of the slope revetment under the jetty will be very troublesome. For a further discussion of design aspects and relevant guidelines, reference is made to EAU 2004 (2012).

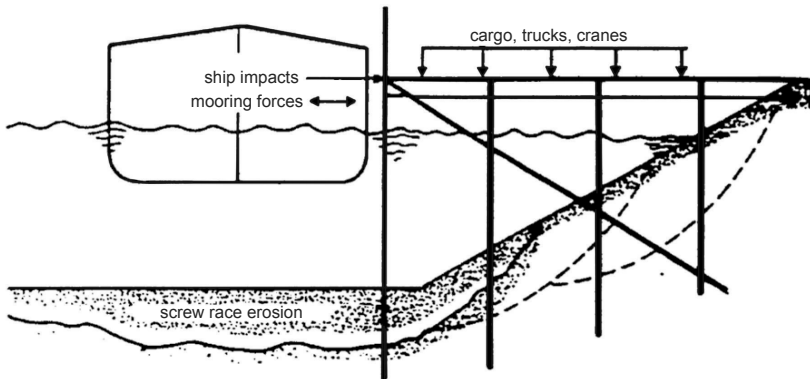

Figure 14.23 Forces acting on a jetty terminal

14.4.6 Inland Passenger Terminals

Even at a pure passenger terminal, a certain amount of cargo has always to be handled, ranging from personal luggage and unaccompanied baggage to crates and barrels for local stores, depots and shops. This sort of cargo is usually light and limited in volume, and is not to be compared with regular freight movements to and from factories or with transport of agriculture products, bulk commodities and the like. Hence, the design of a passenger terminal must not be mixed with the completely different criteria applying to a cargo terminal. Both types of terminal have in common that the jetty, or landing stage, is the most important component. For a passengers jetty, the prevailing requirement is to have a landing platform which is, more or less, level with the vessel's embarkation deck. In most cases,

this will result in the choice for a floating jetty. This is certainly the case for stations where substantial seasonal level variations do occur. In most tidal areas, a fixed jetty with stepped levels may be used.

14.4.7 Seaport Terminals for IWT Vessels and Lighters

In seaports with IWT connections to the hinterland the barges are mostly handled at the same quays as the seagoing vessels. This has several disadvantages:

- i. The cranes are designed for the seagoing vessels and often too large for (un) loading of barges. Hence the efficiency of this operation is too low.
- ii. Due to the difference in cost/day, the seagoing vessels always have priority over the barges. Barge handling is often interrupted, when a seagoing vessel demands the berth space.

In some cases this has led to the separation of the sea terminal and the barge terminal. Examples are the special IWT container terminals at Maasvlakte 1 and 2 in Rotterdam. Although this solution has disadvantages (additional capital costs, extra transport between the main storage yard and the barge terminal), the trend is to create those so-called Barge Service Centres as part of a modern container port.

Lighterage cannot be successfully performed without a special terminal where lighters, or barges, can be loaded or unloaded in an efficient way. Such a terminal can be part of the original port complex, for instance, where shallow berths or space restrictions make the location less suitable to receive any more sea-going vessels. But, more often, a lighter terminal will be located away from the original port site, where new links with the hinterland can be created that bypass congested areas around an old port. Similar to the seaport's IWT complex, but on a smaller scale, the lighter terminal is an intricate set-up where rail, road and water transport modes meet, and where transfer of cargo has to be performed, often complicated by intermediate storage. The throughput capacity of a lighter terminal may range from 1,000 to 2,500 tonnes of cargo per year per meter of quay length, depending on the type of commodities and the efficiency with which they will be handled. The above figure is based on an effective working time of 75% out of the maximum available hours per year, or $0.75 \cdot 24 \cdot 365 =$ say, 6600 active hours.

14.5 References

- CVB, Guidelines Inland Waterways, Rijkswaterstaat AVV, Rotterdam, 2006 (in Dutch)
EAU 2004, Recommendations of the Committee for Waterfront Structures, Harbours and Waterways, Wiley 2012
ESCAP IWT Seminars, The Netherlands, 1988 and 1991
Guide to Inland Water Transport Development, PIANC PCDC 2nd Seminar, Surabaya-Brussels, 1992

Appendix A

(From Taneja, P., *The flexible port*, PhD thesis, Next Generation Infrastructures, 2013)

Adaptive Port Planning applied to port expansion project MV2

1 Background

1.1 Project description

The Port of Rotterdam (PoR), the largest port in Europe and the world's tenth-largest container port (2010), has almost reached its limits in terms of space. In the existing port and industrial area, there is hardly any room left for new companies and existing clients wishing to expand. The MV2 project, an expansion of the existing PoR into the North Sea, is a venture of the Port Authority. The planning of the project was started in 1993, the land reclamation began in September 2008, and the first ship was planned for 2013. The construction will be carried out in phases, and it is only in 2033 that MV2 will be fully operational.

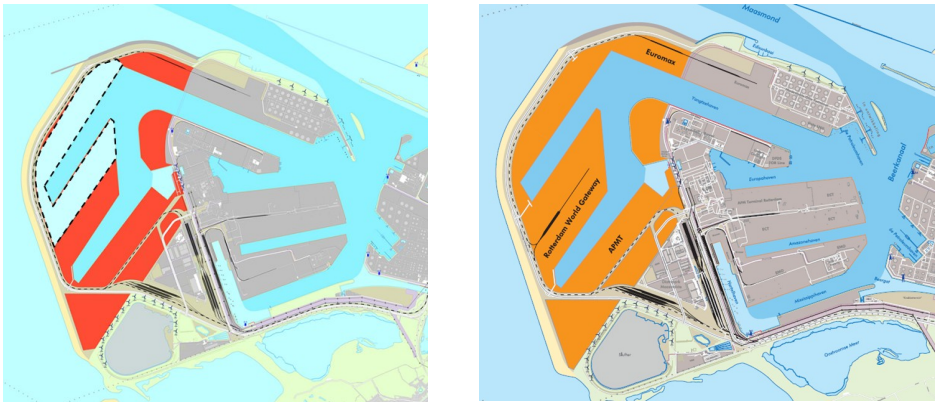

Figure 1: Layout Maasvlakte 2 project

1.2 The Master Plan and Business Case

The Master Plan of MV2, presented in Figures 1(a) and 1(b), has been drawn up on the basis of several assumptions, the most important of course being the projected port traffic and throughput volumes, which are determined by dynamic factors such as market forecasts, client demands, governmental policies as well as various technical, environmental,

economic, financial, and social factors. The Master Plan seeks to allocate the land within the port to the various uses required, aiming at an optimized layout of the port and the port-land interface. Progressive insights as a result of the numerous research studies, regular updating of the market forecasts, input from the contractors and the future clients, have all led to revisions in the Master Plan. It has a central role in the project and forms the basis for tendering and execution of the construction work, taking care of the necessary procedural preparations, marketing MV2 in order to attract clients, thus assuring sufficient return on investments.

The MV2 project is a business case directed project. The business case forms, at every stage, the basis for determining the profitability of the project. If the realization of the desired profit is in danger, changes can be made in advance. Directing the project by means of the business case prevents the creation of sites that would later prove unprofitable. The major elements of this business case are: investments, costs or expenditures, and income or revenue. The Master Plan forms the basis for determining the investment at any stage of the project. The harbour dues, rental fees, and quay dues are the revenue sources for the Port Authority, while the operational costs are the overhead, maintenance costs, nautical services, and working capital. The Master Plan gets more detailed in every cycle as more information becomes available and the business case gets more real. The business case and the Master Plan are closely related and provide managers with the support they need to program the implementation of the overall strategic plan (PMR, 2008).

1.2.1 Objectives

The overall objective of the expansion of the Port of Rotterdam through construction of MV2 is to reinforce the international competitive position of the port and industrial complex (and thereby help strengthen the economic structure of the city and region, thus contributing to the Dutch economy as a whole and contributing to a better residential and living environment in the region). With a total maritime container throughput of 40.1 million TEU in 2008 handled along a shoreline of 500 nautical miles, the Hamburg-Le Havre range (including the ports of Hamburg, Bremerhaven, Amsterdam, Rotterdam, Antwerp, Zeebrugge and Le Havre) ranks among the busiest and most competitive container ranges in the world (Wiegmans et al., 2008).

Besides the Port Authority, the port has other stakeholders, including the terminal operators and/or shipping lines, shippers, trucks and barge operators and of course the whole community that is affected by the construction of MV2. The stakeholders have varied, and sometimes, conflicting objectives. Whereas the port authority is concerned mainly with the financial viability of the terminal, terminal operators also demand flexible space, adequate capacity of waterways, low operating and maintenance costs, reliable handling equipment, good rail and road access, and low land lease rates. The shipping lines demand fast vessel turnaround time, good berthing facilities, around the clock service, and low total costs.

1.2.2 Dealing with uncertainty

Flexibility has been a major goal in the port's masterplanning. The design and construction contract with the building consortium PUMA (JV of Boskalis and Van Oord) gives it an enormous amount of freedom in how it carries out the project. As long as it fulfills the functional requirements, improvement in the design can be carried out after the contract had been signed. Moreover, flexibility in time is achieved by adapting the development of MV2 to the actual market demand, and phasing the implementation of plans. The Port Landlord model makes this possible. There will be still some demand risk exposure when it decides to proceed with each further stage of development. However, once leases have been signed with new terminal operators, the terminal operators will be at the front line and will have to cope with the demand risks, whereas the Port Authority will be protected to some extent from the short term vagaries of the markets (OECD, 2010). Not only does phasing provide possibility for adaptation, but provides more certainty about impact of certain actions (such as the functioning of the created marine reserve).

At the time the first Maasvlakte was conceived, transport via containers was not in the picture. During masterplanning for MV2, an awareness of uncertainty led to use of techniques such as scenario building, uncertainty and risk analysis (Rahman et al., 1999), trend-break analysis (RAND Europe, 1997), and computer-supported simulation gaming (Bekebrede and Mayer, 2006). These were used to gain insights into future developments and to anticipate the uncertainties associated with these developments.

This strategy of anticipation involves an effort towards preventing negative outcomes and can be effective in coping with known threats and problems, but becomes ineffective when uncertainty, dynamics, and volatility increase (Wildavsky, 1991). Under circumstances of deep uncertainty and large risks, robustness can be a successful management and decision strategy. A flexible plan can adapt to the changing conditions under which a port must operate. This approach aimed at 'planned adaptation', allows implementation of the plan to begin prior to the resolution of all the major uncertainties. Over time, when new information becomes available, the plan can be adapted to meet the new conditions.

2 Adaptive Port Planning

We will now illustrate how the proposed adaptive planning approach might be applied to the case study of the port expansion in Rotterdam. Many of the challenges and the solutions have been oversimplified in order to make the planned adaptation approach clear and understandable. This case deals only with the load bearing assumptions that could cause the existing Master Plan of MV2 to fail (it is assumed that the remaining uncertainties could be dealt with through simple measures and good management). The Master Plan is made adaptive through the application of APP. Since we deal with one plan (and not numerous alternatives), Step IV of the plan can be omitted. The remaining steps of the adaptive planning approach, discussed in Section 4.7, are now applied to the case study.

In Step Ia, we define what constitutes the Master Plan of the port expansion, the major constraints and boundary conditions to be kept in mind while applying the adaptive approach, the objective of the plan, and the definition of success. In Step Ib we define our strategy.

Next, we describe a brainstorm session organized at PoR, to discuss the developments or the driving forces in the external environment that can adversely affect the plan by undermining certain assumptions during the lifetime of the project. This exercise helped to identify the load-bearing and vulnerable assumptions in the plan, and constitutes Step II of the adaptive planning approach. In Step III, we define actions that can be taken in the planning phase to make the plan flexible and robust. Step V involves implementing a monitoring system and the start of collection of signpost data. Step VI identifies future actions that can be triggered by the signposts, which can serve to protect the plan.

2.1 Step Ia: Define the project

The Master Plan for MV2 (version 3.2) is illustrated in Figure 1(a). Figure 1(b) shows the end situation in 2033, whereby 625 ha of space is reserved for container terminals, 210 ha for the chemical sector, and 165 ha for the distribution sector. Before the actual construction work began, 40% of MV2 was leased for container handling to the companies APMT, Rotterdam World Gateway, and Euromax. The location of the port expansion, the form of the external contour of the reclamation-area, the port entrance, and the orientation of the port basins, have all been determined after careful study. The west side of the Yangtzehaven is connected to the basin on the east side with a channel, on either sides of which, turning areas for the ships have been created.

The Master Plan, for the purpose of our study, comprises:

- the port layout and detailed drawings;
- associated documents, such as the zoning plan, the PKB (Key Planning Decision), various permits and technical standards;
- the MV2 business case and contracts with investors, clients, and contractors.

When applying adaptive planning to the Master Plan, a major constraint is that there is no possibility for drastic adaptations in the first phase of the Master Plan whereas the following phases give reasonable room to do so.

2.1.1 Definition of Success

The objective of the Port Authority (with the port expansion MV2) can be stated as follows: “to attract cargo flows for the deep sea-related container sector, the chemical industry and the distribution parks, by creating sufficient extra space, in a sustainable manner, directly on the North Sea, while providing high-quality service by handling cargo efficiently and maintaining standards of safety, cleanliness and security”.

This objective could be met if the port development (supply) can be coordinated with the market demand for the three market sectors (the deep sea container sector, the chemical industry and distribution). This would be indicative of a viable business case, implying a safe return on investments for the investors. (To be more specific, the Port Authority has assumed in its business case an internal rate of return of at least 8.55% on their investment and a total cost of 2.9 billion Euro; this amount represents the investment including con-

tingencies at a price level 2006). Success of the business case (that is integrated with the Master Plan) is based on its assumptions on both the supply and demand side remaining valid, and uncertainties, if and when they manifest themselves, being adequately dealt with.

Step Ib is not relevant in this exercise, since we are making an existing Master Plan adaptive.

2.1.2 Major assumptions

Many of the assumptions are related to the current state-of-the-art technology and the existing policies. The major assumptions in the Master Plan are related to:

1. the vessel sizes;
2. the choice of cargo sectors to be handled at MV2;
3. the timing and volumes of market demand in the chosen market sectors (the deep sea-related container sector, the chemical industry, and distribution);
4. the modal shift or the distribution of the hinterland cargo over the three modalities, road, rail and inland shipping;
5. cargo handling concept (equipment and operations) at the quay;
6. cargo handling concept (equipment and operations) in the yard or stacking area;
7. user requirements (e.g. multi-user or dedicated terminal, shared or individual rail and barge service centres, sharing of equipment or not, value added activities or not), and
8. the existing policies/ regulations with regard to standards of security and sustainability (that include, among others, the issues of nautical safety, port accessibility, emissions and noise pollution).

2.1.3 Step II: Identify load-bearing and vulnerable assumptions underlying the plan

As an aid towards identifying load-bearing, vulnerable assumptions in the existing Master Plan and subsequently improving its robustness and adaptability in the face of uncertainty, a brainstorm session was organized at PoR. The aim was of the session was to:

1. obtain strategic insights into the major driving forces or developments in ports and the shipping industry;
2. discuss the implications of these developments for MV2, and
3. identify which of the developments could undermine the assumptions in the Master Plan for MV2.

The external developments that could undermine the assumptions in the Master Plan can be broadly listed under four categories: technology, market and economy, politics and legislation, and environment and society. These developments can influence the demand directly or undermine the other assumptions in the Master Plan. Among others, the planners and decision makers of PoR were invited to participate in the brainstorm session in order to

construct relevant future scenarios and discuss plausible relevant developments. In addition to the experts, the participants also included generalists with a broad view. The session involved four steps:

1. The participants were asked to list on paper plausible future developments for each of the four categories listed above. These developments were not required to be limited to the port and shipping sector. The exact time horizon was not defined; the participants were asked to think in the long term. No probability scale was predefined for the exercise; as a result trend-break scenarios with low likelihood of occurrence as well as foreseeable trend developments appeared in the lists. (Trend scenarios assume that the future will, in all important aspects, be a continuation of the present and the recent past, while trend-break scenarios allow for structural changes in the system.) The developments could be positive or negative; what often seems to be a negative development at first may later prove to be one of hidden opportunity.
2. These lists were then collected, and the large number of plausible developments was reduced to a manageable amount by sorting them into clusters. The developments that could be significant for MV2 were listed for each of the categories.
3. The participants were then requested to list the possible implications of these developments for the port and the port expansion. This could help in evaluating if a particular development could lead to the failure of the plan in its lifetime.
4. The list of impacts was further examined. The developments and the resulting vulnerabilities or opportunities, most likely to be significant for MV2, could subsequently be identified.

Table 1: Some vulnerabilities, and their key driving forces

<i>Major driving forces</i>	<i>Vulnerabilities and opportunities</i>
Port expansion will lead to increased road transport and congestion on A15 highway, which is the major road linking the port to the hinterland Depletion of fossil fuels Increase in energy prices Changing pattern of supply and demand of energy (newly emerging economies) Geopolitical tensions between energy-importing and energy-producing countries Shift toward renewable energy sources such as bio-fuels, wind, solar and nuclear energy	<i>Reduction of land side accessibility</i>
Migration of activities to the west, far from the city Demographic ageing No workers in the port Reduced tolerance for negative environmental impact	<i>Deterioration of city port relationship</i>

Appendix

goes to the stock market

Vertical and horizontal integration in supply chains

Changing port competition due to growing risks and uncertainties

Economy of scope as important as economy of scale

Focus on reliability and capacity in addition to costs

Discontinuous hinterland due to creation of transport corridors

Increasing economic development leading to increasing consumption, e.g. in eastern Europe

Container demand grows faster than forecast

Increasing globalization (diversified market, globally networked production, flexibility of production and labour processes)

Shifting of location of production centres to the west due to instability of low cost economies and increasing transportation costs

Container demand grows slower than forecast

Change in consumption patterns and customer preferences

Protectionist measures

Environmental constraints for sea transport, e.g., stricter controls by International Maritime Organization (IMO) and mandatory 100% container scanning lead to high costs

Use of other trade routes, such as the silk route and Trans-Siberian railroad could mean loss of container traffic from the east

EU requires equal distribution of containers for all ports in Hamburg-LeHavre range, thus no mainports

National legislation becomes stricter than European legislation, leading to unfair competition

Utilization of economies of scale

Increase in quay/terminal productivity

Innovation and new technologies in many disciplines makes mega ships technically and financially feasible

Improved turnaround time for ships

Innovation in equipment and transport

Innovative handling concepts, direct transshipment to different modalities

Improvement in communication and information technology (far reaching management and control of production and transport flows)

Increasing focus on sustainability will demand a shift toward an environmental friendly form of transport

Modal shift in favor of inland shipping

Internalization of costs makes road transport costly, and transport by inland ships competitive

Congestion on road and reduced port accessibility causes hazard for road safety	<i>Non-compliance with standards of sustainability, security and safety</i>
Increase in shipping traffic proves hazardous for nautical safety	
Increasing dependence on technology results in increasing vulnerability	
Low emission quotas specified in the contracts are exceeded	
Reduced container throughput	<i>MV2 must accommodate other cargo sectors and activities</i>
No container handling permitted on MV2 due to negative environmental impact	
No road transport permitted from the port	
Activity and industry from Waal- and Eemhaven area has to shift to MV2 to improve quality of the living environment	
MV2 must become 'energy port' for renewable energy as refineries and petrochemical industry disappears from the port	
PoR goes to the stock market and shareholders insist on space usage with high turnover	
European legislation takes market power from the port	

Table 2: Some wildcards and their impacts

Wildcards	Impacts
Container is replaced by 'mega-box' to utilize economies of scale	New equipment, handling methods, and transport logistics will require enormous investments
New generation container ships, smaller and faster, are designed to achieve greater flexibility	This will stimulate multi-porting instead of main-porting, and the resulting changes in distribution patterns would require new infrastructural investments
Sea level rises faster than expected	As temperatures and water levels rise, all efforts are geared to stopping further damage. Economy and trade suffer
Global climate change leads to extreme weather conditions and large tides, making entrance of ships via Maasmond and Yangtzehaven impossible	Ships will choose to call on other ports
Credit crisis	Access to credit is key to the survival of maritime trade and trade shrinks as the credit markets freeze
Disruption of the information systems controlling port flow	Even a tiny disruption of port operations will affect the entire supply chain
Closure of choke points such as Suez canal, Panama canal, or Strait of Malacca	Longer shipping routes will make sea-transport costly
Fossil fuels are exhausted	Trade and sea transport suffer due to political turmoil and increasing transport costs; production is regionalized

Appendix

Terrorist attacks, cyber warfare, world conflict, unforeseeable social upheaval	Such events could leave the world in a state of shock and disarray, and with a depressed economy
PoR is subject to far reaching European regulations	The competitive position of the port will be threatened

Table 1 gives a list of the major driving forces and the resulting vulnerabilities and opportunities, identified during the brainstorming session. Table 2 lists some trendbreak developments that could have a significant impact on the Master Plan.

2.1.4 Step III: Increasing the flexibility and robustness of the plan

As we have seen, the development of MV2 is complicated by the many diverse trends and developments, which present both vulnerabilities and opportunities. Some of these developments are relatively certain and others are uncertain. The Port Authority can add shaping and mitigating or hedging actions to the current Master Plan. Shaping actions can include promotional or marketing campaigns, tariff regulating strategies, use of concessions and incentives, new collaborations, uncertainty absorbing contracts with the clients, restructuring of vertical relationships with contractors or customers, and instituting new market mechanisms such as bidding and auctioning systems. Mitigating and hedging actions aim at reducing certain and uncertain adverse effects of a plan; this can be achieved by physical alteration to the Master Plan, changes in manner of operation, or diversification.

2.1.5 Certain developments

Some examples of relatively certain future developments (see Table 3) are increase in energy prices, reduction in land-side accessibility, deterioration of port-city relationship (unless actions are taken), and the changing nature of port competition (due to changing function of ports). The actions, in response to these vulnerabilities are listed in the table and discussed further in Section 3.

Table 3: Some Certain Vulnerabilities, and Responses to Them

Vulnerabilities and opportunities	Mitigation (M), Shaping (SH), and Seizing Actions (SZ)
Reduction of landside accessibility	SH Invest in R&D into the landside accessibility in Rotterdam and neighbouring area and new transport alternatives
	SH Use price strategies, internalize external costs in pricing of road transport to stimulate transport by rail and inland ships
	M Invest in a network of container transferia, inland container depots (extended gates concept)
	M More TEU per truck, night shifts for trucks, and improvement in cross border rail connections in Europe
	M Invest in infrastructure for inland ships

Ports and Terminals

	M	Stimulate transshipment
	M	Invest in underground infrastructure
Energy price rise in the long term	SH	Invest in R&D into cost-efficient renewable sources of energy
Deterioration of cityport relationship	SH	Improve living environment in the city
	SH	Attract new activities and stimulate economic renewal in the city area
	SH	Make the port attractive by stimulating recreational and multicultural activities
Changing port competition	SH	Invest (timely) in infrastructure and hinterland connections, investment in R&D
	SH	Offer integrated services and increased reliability and safety
	SH	Diversify, also in non-port-related activities increasing the capacity to absorb losses and cross-subsidize within the port
	SH	Assume role as facilitator in the supply chain

Table 4: Some Uncertain Vulnerabilities, and Responses to Them

Hedging (H) and Shaping (SH) actions		
Container demand grows faster than forecast	SH	Negotiate uncertainty absorbing contracts (additional income from the concessionaire)
	H	Invest in modular, interoperable infrastructure
	H	Invest in improving hinterland connections
	H	Adapt Master Plan
Container demand grows slower than forecast	SH	Stimulate promotional or marketing activities by PoR as well as the terminal operator
	SH	Negotiate uncertainty absorbing contracts (compensation by the concessionaire)
	H	Invest in modular/flexible infrastructure
	H	Spread risk by diversification into other cargo or non-port-related functions, such as real estate
Mega vessels appear (a): ships bigger than 12,500 TEU and smaller than 18,000 TEU, length more than 450 m)	SH	Competitive advantage for MV2, set up positive campaign, increase tariffs
	H	Define new nautical rules, reduce ship speed in basins for certain wind conditions and passing ships
	H	Reserve budget for dredging, bollards, fenders, bigger tugboats
Mega vessels appear (b): ships bigger than 18,000 TEU (draught less than 17.4 m; length more than 450 m)	SH	Set up negative campaign against mega ships, announce increased tariffs
	H	Invest in R&D to study feasibility of ship size and nautical requirements
	H	Re-evaluate Master Plan and redefine nautical rules
	H	Invest in R&D to study implications and adapt Master Plan

Appendix

Increase in quay and terminal productivity	SH	Negotiate uncertainty absorbing contract with operator
	SH	Terminal operator must invest in improving hinterland connections
	SH	Invest in R&D to study implications
	H	Adapt Master Plan to accommodate reduced demand for space
Modal shift in favor of inland shipping	SH	Set up positive campaign to stimulate this development
	SH	Invest in R&D to study implications for the Master Plan
	H	Adapt Master Plan, provide additional facilities for inland ships
Non-compliance with standards of sustainability, security, & safety	SH	Install monitoring systems
	H	Impose penalties, fines, internalize external transport costs to discourage transport costs
	H	Invest in road and underground transport infrastructure, widen waterways

Uncertain developments

Most of the identified developments are uncertain. The real challenge for the development of MV2 is presented by the uncertain vulnerabilities and opportunities. The timing and volume of demand, ships that will call at the port in the future, technological innovation leading to increased productivity, modal shift in favour of inland shipping, and non-compliance with standards of safety and security, are all vulnerabilities for the Master Plan. The vulnerability of other cargo sectors to be accommodated at MV2 than in the present Master Plan is treated further as a wildcard. Table 4 presents some of the hedging and shaping actions that can be taken now to handle these vulnerabilities. Further discussion follows in Section 3.

2.1.6 Step IV: Evaluate and select alternative

Step IV involving selection of alternatives is omitted.

2.1.7 Step V: Set up a monitoring system

Step V sets up the signpost monitoring system, specifies the triggers, and identifies the actions to be taken when trigger levels of the signposts are reached. Triggers are very often the performance indicators of an organization. No generic performance indicators exist for ports. However, the performance of seaports as a whole is traditionally assessed by comparing throughput, e.g. in terms of tonnage or number of containers handled, while port authority performance indicators measure berth or crane utilization, tonnage handling, and waiting times. In the case of stevedores, performance indicators include the number of vessels and cargo handled, the cargo handling rate, containers handled per crane, units per man/shift, number of employees, average hours worked per week. Shipping line performance indicators, on the other hand, are concerned with the possible delays: the average delay to vessel awaiting berths, the average delay alongside berths or non-productive time (Notteboom, 2003).

Table 5 shows the signposts to be set up for each of the vulnerabilities and opportunities presented in Table 4, and the possible responsive actions in case of trigger events. The numbers used as triggers are illustrative and need to be researched, as do the selected triggers. The tables are by no means complete and are intended only to illustrate the adaptive approach for dealing with uncertainty.

Table 5: Contingency Planning

Vulnerabilities and opportunities	Monitoring and trigger system (active from 2013 onwards)	Actions (Reassessment (RE), Corrective (CR), Defensive (DA), Capitalizing (CP)) to be taken in implementation phase
Container demand grows faster than forecast	Monitor throughput and number of ships	
	If demand increases by 25% take DA-action	DA Use strategic land reserves and form strategic alliance with ports of Amsterdam and Antwerp
	If demand doubles, take CP- actions	CP Speed up expansions
		CP Invest in common transshipment hub for ports in Hamburg-LeHavre range at a strategic location
	If demand explodes, take RE- action	RE Reassess next phase of Master Plan
Container demand grows slower than forecast	Monitor throughput	
	If throughput is less than half of forecast, take DA-actions	DA Delay investments, and reduce tariffs
		DA Diversify into other industries
	If throughput decreases below 30% take CR-action	CR Cancel further expansions
	If demand fully breaks down, take RE-action	RE Reassess entire Master Plan
Mega vessels appear (a): ships bigger than 12,500 TEU; smaller than 18,000 TEU appear (draught less than 17.4 m; length more than 450 m)	Monitor developments	
	If no. of ships per year <10 take DA-action	DA Define nautical rules with respect to wind, passing ships, turning circles, etc
	If no. of ships per year <30 CR-action	CR Invest in bollards, fenders, bigger tugboats
	If no. of ships per year >30 take CP or RE action	CP Adapt infrastructure to handle bigger ships
RE RE: Reassess next phase of Master Plan		

Mega vessels appear (b): Berthing or access for ships bigger than 18,000 TEU (draught approx. 18 m; length more than 450 m)	Monitor developments		
	If no. of ships per year <10 take DA-action	DA	Negotiate with Euromax phase 1 and adapt one berth to receive larger ships
	If no. of ships per year <30 take CR-actions	CR	Consider dredging of Euro-geul to increase tidal window; widen Yangt- zehaven; adapt one berth for bigger ships and define nautical rules with respect to towage, turning, passing ships, etc.
	If no. of ships per year <50 take CP-action	CP	Consider common transshipment hub for ports in in Hamburg-LeHav- re range at a strategic location
Mega vessels appear (c): Handling ships bigger than 18,000 TEU	If no. of ships per year =>50 take RE-action	RE	Reassess next phase of Master Plan
	Monitor developments		
	If no. of ships per year <10 take DA-actions	DA	Discuss terminal concept with operator
Increase in quay/terminal productivity	If no. of ships >50 take CR- action	CR	Terminal operator must invest in improving hinterland connections, e.g., in a network of inland contain- er depots and container transferia
	If no. of ships per year >100 take RE-action	RE	Reassess next phase of Master Plan
	Terminal operator must give ade- quate warning over new terminal or logistic concept (if different from business case)		
	If productivity increases by 20% take DA-action	DA	Extra transport to hinterland not by road, only by inland shipping
	If productivity increases by 30% take CR-action	CR	Terminal operator must invest in improving hinterland connections and in network of inland container terminals and container transferia
Increase in quay/terminal productivity	If productivity increases 40% take CR- and RE-action	RE	New agreement over profit sharing with terminal operator
		RE	Reassess next phase of Master Plan due to reduced demand for space
Modal shift in favour of inland shipping	Monitor modal split		
	If share for inland shipping >45% take CR-action	CR	Invest in berths for inland shipping
	If share for inland shipping >55% take RE-action	RE	Reassess next phase of Master Plan

Non-compliance with standards of sustainability, security and safety	Monitor shipping traffic, road and rail movements, emissions, noise, water quality, etc.	CR	Penalties for the users
	If standards are not met, take appropriate CR-action		

2.1.8 Step VI: Contingency planning for the selected plan

This step involves preparing defensive, corrective and capitalizing actions (see Table 5). The planning phase will be followed by an implementation phase, during which actions specified in Tables 3 and 4 under Step III, and the monitoring plan and contingency plan specified in Table 5 will be implemented. During implementation, the signposts might indicate for example, that a vulnerability of the plan has appeared in the form of increased or lowered demand, or that the norms established for safety, security, and the quality of the living environment have been violated. The actions specified in Table 5 would then be implemented.

The land reclamation for MV2 was started in September 2008, and in 2013 the first phase will be fully operational. Many of the actions proposed in Tables 3 and 4 are already being taken by the Port Authority and the literature pertaining to them can be found in the Environmental Impact Assessment documents (Projectorganisatie MV2, 2007).

3 Adaptive port plan

3.1 Impact-Probability chart

Risk mapping is a tool used by organizations for managing risks, through first prioritizing them, then deciding which of the risks should be addressed, and subsequently, allocating resources for dealing with them. In this section, we rank the uncertainties identified in Step II, on a impact-probability (risk) chart (Figure 2). Though the impacts of the vulnerabilities we have identified can be estimated in various ways, e.g. in terms of loss in the market share, reduction in service level, reduced returns etc., we assess the impacts of the uncertainties based on the adaptations required in the Master Plan. The assessment is purely qualitative. As can be seen, all the uncertainties have a (medium to) high impact on the plan. Further, the probabilities assigned to the vulnerabilities in this graph are purely for illustrative purposes. Nevertheless, the graph is useful for the subsequent discussion over how the actions proposed in Steps III and IV, for each of the vulnerabilities, can either lower their impact and/or decrease their likelihood. The direction of the arrow indicates if the probability and/or impact of the vulnerability can be reduced through the proposed actions.

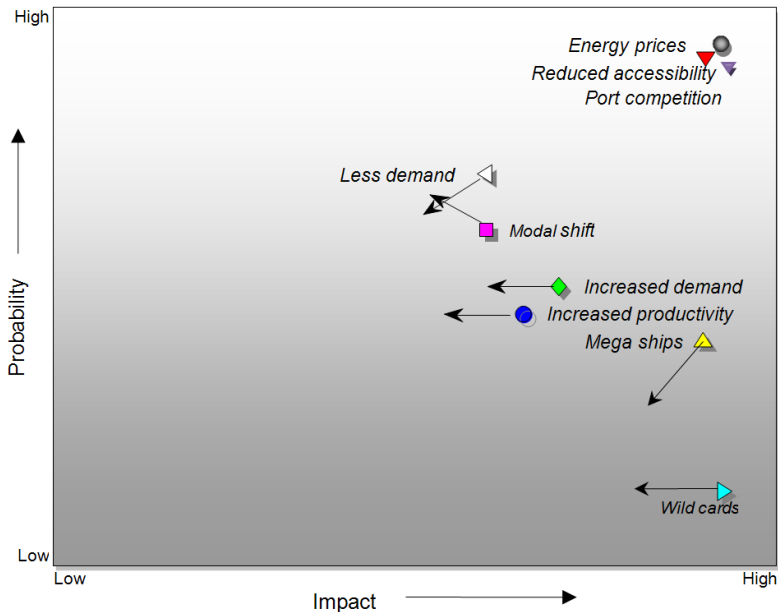

Figure 2: Impact-Probability (Risk) chart

3.1.1 (fairly) Certain developments

The fairly certain developments lie in the top half of the impact-probability chart. The vulnerabilities in this high-impact, high-probability zone need to be addressed.

Land side accessibility is a major vulnerability for the port and the situation will worsen with further development of the port. A shaping action for this vulnerability could be to invest in R&D into innovative solutions, and employ tactics that will make transport by inland ships competitive. Mitigations could be in form of new logistic concepts, such as a network of inland container depots and container transferia in the hinterland of the port, trucks that can transport more TEUs at one time, night shifts for road transporters, and improvement in cross border rail connections in Europe. Widening of the access road to the port, investment in infrastructure for inland ships and underground infrastructure (Oranje tunnel and Blankenburg tunnel) could also be possible mitigations.

Crude oil and natural gas prices will increase in the long term, due to growing demand and reduced supply, unless there is breakthrough in the area of alternative cost-efficient sources of energy. A shaping action, to invest in research and development of new technologies, will increase the chance of this happening, but offers no guarantees.

Deterioration of city-port relations can be prevented by improving the living environment in the city, and stimulating economic and recreational activities in the port and city area.

3.1.2 Wildcard or trend-break developments

Wildcards belong at the bottom right corner of the impact-probability chart. Sea level rise, global climate change, credit crisis, terrorist attacks, and policy changes, are all examples of wildcards. Wildcards can only be handled through contingency planning; specific strategies and actions to reduce their impact just in case they do occur is the closest we can come to handling these uncertain developments. Sometimes survival of the organization depends on handling these vulnerabilities. The great Hanshin earthquake that destroyed the Japanese port of Kobe on January 17, 1995 provides an excellent example of dealing effectively with a wildcard. At that time, Kobe was Japan's biggest international trade hub and a major production and logistics center. The global impact of closure of the port was mitigated by the fact that a large part of Kobe's business involved the handling of containers and that the container-handling infrastructure was relatively standardized in most Japanese ports. The diversion of container ships to the neighbouring ports was accomplished with relative ease and with minimal delays. The worst fears of the closure of Kobe paralyzing global trade did not materialize.

Some wildcards, relevant for our case study, are listed in Table 2, but are not discussed further.

3.1.3 Uncertain developments

The uncertain vulnerabilities that we have identified are likely to have a medium to high impact on the plan, and the probability or the level of risk also varies between medium to high in Figure 2. In the planning phase, the available choices are to lower their impact through hedging actions or lower their probability through shaping actions. In the implementation phase, defensive, corrective and capitalizing actions will protect the plan.

Container demand grows faster or slower

The realization of MV2 is planned in stages. New port and industrial areas are created only when there are clients. The optimal condition would be if the market demand for each sector materializes exactly as envisaged in the business case and can be co-ordinated with the realization of new port areas. Any deviations will have an impact on the business case. However the timing (and volumes) of future market demand remains uncertain.

The capacity and design of the port's major facilities (such as the shipping channels, berths, equipment, storage areas, the internal road and rail connections and the hinterland connections) are dictated by the traffic forecasts. Increased demand (beyond the bandwidth defined to take into account the uncertainties) presents an opportunity and the contract with the terminal operator should allow the port to benefit from this development. However, unless adequate infrastructure and space is available, this development can lead to congestion in the terminal and in the hinterland, and reduced service. A shaping action would be to negotiate a contract that ensures income from this development.

A hedging action would be to plan modular terminals that are flexible and can be expanded or downsized. If demand increases, say by 25%, speeding up expansion plans and until that

time using the strategic reserve space, and creating alliances with the neighbouring ports of Antwerp and Amsterdam, will reduce the adverse impacts of this development. If demand increases, say by 50%, the ports in the Hamburg Le- Havre range could invest in a common terminal at a strategic location. If the demand explodes, the plan would need reassessment. In case of reduced demand, demand guarantee clauses in the contract with the terminal operator will safeguard the interests of the port authority. Shaping actions to attract cargo, such as lower tariffs or added service, could reduce the probability of this development. However, investment in modular and flexible infrastructure (also called building in physical options) easily up-scaled or down-sized, will make diversification into other cargo sectors and markets easier. Diversification in port and non-port related activities will make absorption of losses and cross-subsidization within the port easier. If demand is less than half of forecast, delay investments. If demand breaks down, reassess the entire Master Plan.

Mega vessels appear

Once the land has been reclaimed and the fixed infrastructure such as channels and basins created, the port must be able to accommodate future ships. As technology improves, ships size continues to evolve in order to utilize the economies of scale. Appearance of ships bigger than the ship size assumed in design of the port infrastructure poses a threat to the plan. PoR is via the Eurogeul and Maasgeul, accessible for ships with a draught up to 22.50 m, (though access for ships with a draught greater than 17.40 m is tide-related).

The largest design ship in design of MV2 is a 12,500 TEU ship with a length of 382 meter and draught of 17.0 m. On the basis of this design ship, a depth of NAP -20.0 meter will be provided for safe navigation and berthing. Research has established that ships with a length of 450 meter can carry out all manoeuvres, though under certain restriction of wind conditions, other shipping traffic, and speed. Thus, if ships in the range of Malacca-max with a length of 450 meter, a draught of up to 18.0 meter, and a capacity of up to approx. 18,000 TEU were to appear, the development would offer an opportunity for MV2. Redefining nautical rules and increasing tariffs, corrective action such as investing in larger capacity bollards, fenders and tugboats, and adapting part of the infrastructure could be actions of the Port Authority.

If ships with a length greater than 450 meter, or draught more than 18.0 m were to appear, depending on their call frequency, measures would be necessary (see Table 5). The probability of ships bigger than Malacca-max appearing in the future can be reduced through shaping actions, whereby organizations such as International Maritime Organization (IMO) or European Seaport Organization (ESPO) set up a negative campaign against such vessels, which are bound to place additional demands on port infrastructure and in turn cause extra ecological and societal pressure.

A capitalizing action could be to adapt the Master Plan now. In the event that these vessels do appear, but have a call frequency of say 50 ships a year, a hedging action could be for the shipping companies and the ports in de Hamburg-LeHavre range to invest in a common transshipment hub terminal at a suitable location. Not all ports would be required to invest in dredging and infrastructure to handle these mega vessels. A defensive action, if the ships

call only about once a month, could be to adapt one berth at the existing Euromax terminal in order to handle these ships, since the first 600 meter of Yangtzehaven will be widened to create berths for inland ships. If the ships call, say 3 times a month, an additional corrective action could be increasing the capacity of Maasgeul and Eurogeul (meanwhile, the widening of Maasgeul by 240 m is already being carried out).

Increase in quay and terminal productivity

Increased productivity (handling speed of containers measured in TEU per quay length or TEU per terminal area) will benefit the terminal operator. The Port Authority must invest in R&D to study the implications of this development. The terminal operator must give adequate warning if the terminal concept is other than in his business case, and arrive at agreement over profit sharing with the port. Therefore, he must ensure that the extra transport is by other means than road, invest in reducing dwell times of containers, improving hinterland connections and create a network of inland container terminals and container transferia. These actions will reduce the adverse impact of this development, namely congestion at the terminal and in the hinterland, reduced service and negative environmental impacts.

Modal shift in favour of inland shipping

If there is a modal shift in the favour of inland shipping (environmental friendly mode of transport compared to road and rail), the positive effects of this development should motivate extra investment by the government, since it is responsible for the construction and maintenance of adequate connections to the hinterland. Investment in additional infrastructure for inland ships and measures for promoting the transition from road to water transport would help the port, which will experience only a limited impact from this development.

Non-compliance with security and safety standards

The port development in the Netherlands is guided through national and European policy documents (national seaport policy documents prepared by the Ministry of Infrastructure and Environment and European policy documents prepared by European Maritime Safety Agency, which set down requirements for maritime safety, pollution by ships and maritime security), and codes of practice on environmental and social issues established by European Sea Ports Organization.

In order to remain viable, modern ports must be able to accommodate larger vessels and a much greater volume of throughput more cheaply and efficiently than ever before, without increasing the potential for environmental damage. This could result in changes in the national legislation or creation of new European Union Directives geared towards stricter regulations in order to maintain standards of sustainability, safety, and security. These would be risks for the existing Master Plan.

One of the principles underpinning the MV2 expansion is that even if shipping traffic increases, security levels in and around the port complex must stay the same. This is why there has been extensive research into which measures can be taken to safeguard the current security levels. Norms have been specified as to the emission of fine dust and CO₂, noise, and accessibility of the port for emergency services. If the required standards of sustainability, safety, and security are not met, due to any reason whatsoever, the plan will be threatened. Installing monitoring systems, and monitoring and imposing penalties in case of more than 10% increase in the levels specified in the norms, would be corrective actions.

4. References

- Bekebrede, G. and Mayer, I., Build your seaport in a game and learn about complex systems. *Journal of Design Research*, 5(2):273–298, 2006.
- Notteboom, T., Current issues in port logistics and intermodality. Antwerp/ Apeldoorn: Garant, 2003
- OECD, Transcontinental infrastructure needs to 2030 / 2050 North-West Europe gateway area - Port of Rotterdam case study, 2010. Available at: <http://www.oecd.org/data-oecd/12/54/48321781.pdf>. Accessed 1 April 2011.
- PMR, Masterplan Maasvlakte 2, werkversie 8 . Technical report, Rotterdam Mainport Development Project, Port of Rotterdam, 2008.
- Rahman, S., Malone, K., Van de Kerke, B., and Vader, J., Onzekerheidsanalyse van de Ruimte vraag in de Haven van Rotterdam [Risk Analysis of the Demand for Space in the Port of Rotterdam], RE-99-014, RAND, Santa Monica, CA, 1999. Available at: http://www.rand.org/pubs/rand_europe/RE99-014.html. Accessed 1 April 2012.
- RAND Europe, Maasvlakte 2: Trendbreukanalyse [Trend break analysis], RE-97.04-MV. Rand Europe and Projectorganisatie Maasvlakte 2, 1997.
- Wiegmans, B., Van der Hoest, A., and Notteboom, T., Port and terminal selection by deep-sea container operators. *Maritime Policy Management*, 35(6):517– 534, 2008.
- Wildavsky, A. B., Searching for safety. NJ, USA: Transaction publishers, New Brunswick, 1991.

Index

A

acceptable wave action at the berths 295
Adaptive Port Planning (APP) 56
added mass 248
AEIS (Automatic Equipment Identification System) 181
all-weather terminal 213
ammonia 33
annual berth capacity 265
APMT 342
approach bridge 244
approach channels 111
auto-disconnect 253

B

basic manoeuvrability 96
basin width 294
batch weighing methods 282
bathymetry 63, 64
bauxite/alumina 262
beam 9
berthing dolphins 247
berthing energy 251
berthing facilities 226
berthing or breasting dolphins 245
berth lay-out 227
big coastal vessels 290
bollards 333, 336
bow-out mooring system 314
Brahmaputra/Ganga river system 333
break-bul 11
breakwaters 316
breasting dolphin 251
breasting dolphins 246
bridge system 230
Built-Operate-Transfer (BOT) 50
bulk cargo 28
Bulk commodities 280
buoy body 258
buoy recordings 65

C

car carriers 22
cargo blending 275
carrier haulage 48
CBA 71
chain conveyor 270
channel bound traffic 112
channel depth 116

Chart Datum (CD) 117
climate 64
coal 262
coal slurry pipelines 274
cold storage 304
configuration coefficient C_c 249
consignee 215
Container Security Initiative (CSI) 210
container terminals 143
container types 163
container vessels 16
continuous self unloader 35
continuous unloading systems 265
continuous weighing 282
Conventional Buoy Moorings (CBM) 255
conventional sheltered port 239
Cost Benefit Analysis 72
course control 99
crash stop 98
cream digging rate 265
crude oil tanker 29
cruise ships 25
cruise terminals 147
cryogenic transport 33
cubic number 292
current force coefficient 107
current forces 105

D

deadweight tonnage 5
degrees of freedom 100
demersal 290
density currents 134
design capacity 265
dolphin piles 251
draught of a vessel 8
dry bulk cargo 261
dry bulk carriers 34
dry bulk terminals 143
dry infrastructure 139
dwell time 152
Dynamic UnderKeel Clearance (DUKC) 120

E

effective capacity 265
eigen period 103
Electronic Data Interchange (EDI) 4
entrance 313
entrance speed 123
Environmental and Social Impact Assessment (ESIA) 53

- equipment designer 265
ethylene 33
Euromax 342
European Sea Ports Organization 356
evaluation techniques 70
excitation 100
exposed jetty terminals 253
F
factory ships 290
fast ship 28
Fast Time Simulator (FTS) 113
feeder 36
feeder ships 37
ferry 26
ferry and cruise terminals 147
ferry terminals 226
final stopping distance 123
financial analysis 71, 72
Financial-IRR (FIRR) 74
financial optimisation 81
fingerpiers perpendicular to the quay 296
fish flow 301
fish handling facilities 145
fish hold capacity 293
fishing techniques 290
fixed jetties 317
floating breakwaters 316
floating pier systems 314
forklift trucks (FLT) 216
free digging rate 265
free-falling material 280
free floating vessel 100
fruit terminals 144
fugitive type 129
full or cellular container ships 16
G
gateway terminal 186
general cargo ship 11
general cargo terminal 140
Global Reporting Initiative (GRI) 86
grain 262
green port concept 58
Gross Domestic Product (GDP) 61
gross register tonnage 5
H
handbook for planners 62
harbour approach channels, design guidelines 111
heaving 103
heavy lift carrier, HLC 24
high-sea vessels 290
hindcast computations 65
hinterland connections 216
hub-and-spoke 37
human resources 139
I
IAPH (International Association of Ports and Harbours) 83
ice factory 304
incident wave period T_a 100
incident waves 104
inland barge terminals 145
inner channel 125
intermediate storage 137
International Ship and Port Facility Security (ISPS) Code 210
Iquitos 319, 333
island berth 143
J
jetty head 244
L
landlord port 50
lash ship 23
layout development 66
Le Havre 39
length 8
Lift Automated Guided Vehicles (Lift AGVs) 189
lighter aboard ship 23
linear loaders 276
liner trade 37
Liquefied Natural Gas, LNG 33
Liquefied Petroleum Gas 33
liquid bulk carriers 29
liquid bulk terminals 143
liquid gas tanker 33
littoral transport 131
Lloyds Register of Ships 38
LNG 33
load capacity 236
Lowest Astronomical Tide (LAT) 117
M
Maasvlakte 2 95
main port 37
major bulk 261
Marcona Corporation 274
marginal pier 295
marginal quay 138

Index

- market hall or shed 301
- MARPOL 29, 58
- maximum annual capacity 148
- mega carriers 37
- minor bulk 261
- Mississippi 319
- moored ships 103
- mooring dolphins 245
- mooring facilities 314
- morphological aspects 131
- Multi-Criteria-Analysis (MCA) 70
- multi-port discharge 275
- multipurpose ship 13
- multi-purpose terminal 141
- MV2 339
- N
- natural roll period 100
- nautical depth 120
- nautical safety 123
- Net Register Tonnage, NRT 5
- New Panamax 17
- NSTR 10
- O
- oblique berthing 295
- OBO carriers (ore/bulk/oil) 263
- offshore multiple buoy moorings (MBM) 240
- offshore terminals with floating storage 240
- Oil Companies Marine Forum 245
- operational storage capacity 255
- organisation of seaports 49
- organ pipes 131
- P
- Panamax 16
- parcel tanker 32
- parking area 229
- passenger ferries 147
- peak capacity 265
- pelagic 290
- phosphate 262
- PIANC 111
- pitching 102
- port basins 125
- port entry speed 98
- Port Life Cycle theory 47
- Port of Rotterdam, (PoR) 339
- Post New Panamax 17
- Post Panamax 17
- pressure or blowing types 267
- product tanker 31
- project optimisation 79
- Public Private Partnership (PPP) 50
- PUMA 341
- Q
- Q-Flex 236
- Q-Max 236
- quarter ramp 21
- quay apron width 299
- quay length 199, 218
- quay level 300
- quays and jetties 150
- R
- radial loaders 277
- Real Time Simulator (RTS) 114
- reclaimers 280
- reefer 14
- refrigerated general cargo ship 14
- resiltation factor 134
- resonance 100
- Response-Amplitude Operator (RAO) 101
- revolving grabbing crane 266
- river port with lock gate 324
- rolling 102
- Ro/Ro container ships 225
- Ro/Ro ferries 225
- Ro/Ro ships 225
- Ro/Ro Terminal 141
- Ro/Ro Vessels 19
- Ross-Mosenberg type 236
- Rotterdam World Gateway 342
- rudder efficiency 96
- S
- safety of life at sea 58
- safety requirements 237
- sailing ships 99
- saw tooth quay shape 295
- SBM buoy 258
- sediment deposition 134
- seismic conditions 66
- self unloader 139
- service port 49
- service time 226
- SHIPMA model 114
- short sea trader 36
- siltation of approach channels 133
- single buoy moorings (SBM) 240
- slip/finger arrangement 314
- slipway 301

- slip width 315
- small boats 313
- small coastal vessels 290
- Smart Card 4
- Social-Cost-Benefit analysis, SCBA 71
- SOLAS 58
- stacker-reclaimers 280
- stevedoring assistance 275
- stopping distance 98
- sub harmonic wave forces 103
- Suez Canal 38
- suprastructure 139
- surface marker buoy 255
- Sustainable Development Goals (SDG's) 82
- sustainable port development 82
- SWAN 65
- T
- technical optimisation 80
- technical planning 60
- terminal building 228
- terminal capacity 148
- terminal equipment 139
- terminal lay-out 220
- TEU (Twenty feet Equivalent Unit) 162
- tidal window 119
- tool port 50
- traffic function 45
- tramp trade 37, 38
- transport capacity 5
- transport chain 48
- transshipment 37
- transshipment or hub terminal 186
- turning manoeuvre 97
- U
- Ultra Large Container Vessels 17
- Ultra Large Crude Carriers 31
- underkeel clearance factors 117
- V
- vacuum or suction types 267
- vertical screw conveyor 270
- Very Large Crude Carriers, (VLCC's) 31
- Very Large Ore Carrier, (VLOC) 34
- Vessel Traffic Service (VTS) 45
- W
- wave agitation 126
- wave conditions 64
- wave forces 104
- wave penetration 127
- wave spectrum 101
- weighted average costs of capital (WACC) 75
- wet infrastructure 138
- wharf 138
- wind forces 109
- World Association for Waterborne Transport Infrastructure (PIANC) 111
- Y
- yachtsmen 309
- Z
- Zeebrugge 95

Ports and Terminals

Han Ligteringen

By nature port planning is a multidisciplinary activity. It involves expertise in the field of transport economics, shipping, nautical matters, safety and logistics. But also knowledge of waves and currents, sediment transport and coastal morphology, dredging and land reclamation, and design of breakwaters and quays. Hence port planning is teamwork. But within this team the port planner plays a central role in developing the concepts and obtaining the required expertise at the right time. Most port planners are civil engineers with hydraulic engineering training and experience. The first part of this book (Chapter 1 through 6) is aimed at providing the basic elements to perform this planning process. In Chapter 7 the detailed planning of container terminals is treated, including the logistic process. Further attention is paid to design aspects, typical for such terminals. The objective is to provide the basis for an all-round port engineer, somebody who can participate in the design of any given type of port or terminal. Chapters 8-14 present the planning aspects of other types of terminals.



Prof. han Ligteringen

TU Delft | Civil Engineering & Geosciences

Prof. Han Ligteringen started his career as Associate Expert for UNDP at the Ipoh Politechnic in Malaysia. Thereafter he worked during more than 12 years at Delft Hydraulics (now Deltares) on advisory projects and research in maritime structures, density currents and port engineering and became head of the Maritime Structures department. Subsequently he combined technical and managerial responsibilities at several consulting companies. He occupied the chair of Ports and Waterways at the Faculty of Civil Engineering and Geosciences of TU-Delft from 1995-2010. During this period he was responsible for the education and research within the Ports and Waterways group. He initiated and developed the Port Research Centre Rotterdam-Delft, a collaboration between TU-Delft and the Port of Rotterdam, and the Waterway Research Program with Rijkswaterstaat.



© 2021 TU Delft Open
ISBN 978-94-6366-470-7
DOI: <https://doi.org/10.5074/T.2021.005>

textbooks.open.tudelft.nl